





4

3

2

1

REVISION				
ECO	REV	DESCRIPTION	DATE	APPROVED
---	1	PRELIMINARY RELEASE	04-AUG-22	LM

-  PMS 3535
-  PMS 2995
-  BLACK
-  WHITE

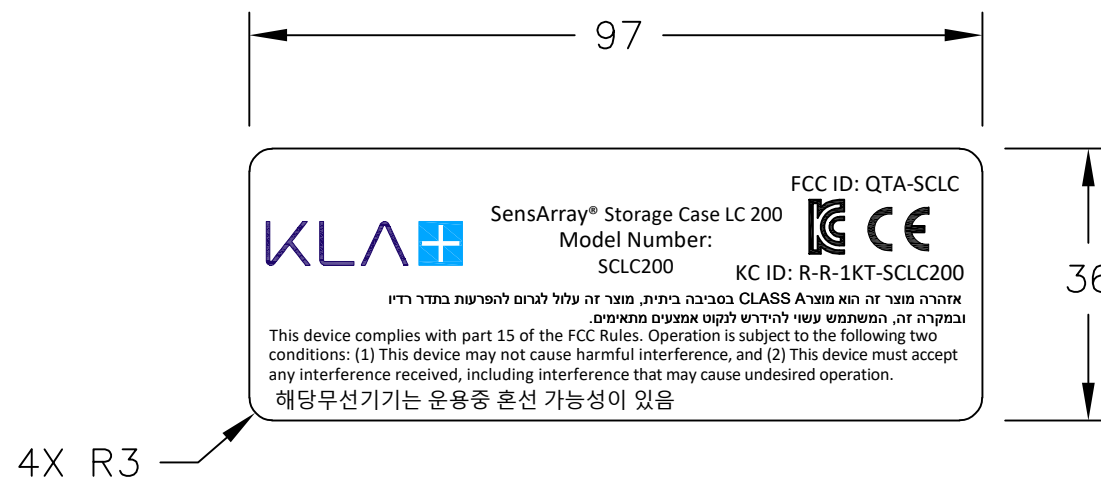

NOTES (UNLESS OTHERWISE SPECIFIED):

- BASE MATERIAL: .05mm (.002") WHITE MYLAR.
- OVERLAMINATE: .03mm (.001") CLEAR POLYESTER.
- ADHESIVE BACKING: PREMIUM ACRYLIC.
- WITHOUT EXEMPTION, ALL MATERIALS THAT MAKE UP THIS PART ARE TO BE RoHS AND REACH COMPLIANT, INCLUDING COATINGS .

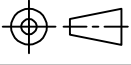
THIS DRAWING CONTAINS PROPRIETARY INFORMATION AND IS NOT TO BE USED OR REPRODUCED WITHOUT THE PERMISSION OF KLA CORPORATION. Copyright © 2019 by KLA Corporation. All Rights Reserved. DO NOT SCALE DRAWING	TOLERANCES UNLESS OTHERWISE NOTED			SIGNATURE		DATE	 LABEL, STORAGE CASE 200LC
	0 PLC	1 PLC	ANGLE	DETAIL	HCL	04-AUG-22	
	±1	±1	±.5°	APP'D	M.LEI	04-AUG-22	
	REMOVE BURRS & SHARP EDGES			APP'D			
SURFACE FINISH NONE ✓			THIRD ANGLE PROJECTION				
MATERIAL SEE NOTES			DIMENSIONS ARE IN MM			SIZE B	DRAWING NUMBER 1009277-000
			FINISH SEE NOTES			SCALE NONE	SHEET 1 OF 1

4

3

2

1