

## FCC IC Test Report

**Report No.:** FCC\_IC\_SL18121801-KLA-021-Co-location Rev\_1.0

**FCC ID:** QTA-AF120

**IC:** 10516A-AF120

**Test Model:** AF120

**2.4GHz WiFi Module FCC ID:** 2ABCB-RPI3BP

**2.4GHz WiFi Module Model:** Raspberry Pi 3 Model B+

**Received Date:** 03/13/2019

**Test Date:** 03/13/2019 and 02/21/2020

**Issued Date:** 02/28/2020

**Applicant:** KLA Corporation

**Address:** One Technology Drive, Milpitas, CA 95035

**Issued By:** Bureau Veritas Consumer Products Services, Inc.

**Lab Address:** 775 Montague Expressway, Milpitas, CA 95035, USA

**Test Location (1):** 775 Montague Expressway, Milpitas, CA 95035, USA

**FCC Registration / Designation Number:** 540430/4842D



This report is for your exclusive use. Any copying or replication of this report to or for any other person or entity, or use of our name or trademark, is permitted only with our prior written permission. This report sets forth our findings solely with respect to the test samples identified herein. The results set forth in this report are not indicative or representative of the quality or characteristics of the lot from which a test sample was taken or any similar or identical product unless specifically and expressly noted. Our report includes all of the tests requested by you and the results thereof based upon the information that you provided to us. You have 60 days from date of issuance of this report to notify us of any material error or omission caused by our negligence, provided, however, that such notice shall be in writing and shall specifically address the issue you wish to raise. A failure to raise such issue within the prescribed time shall constitute your unqualified acceptance of the completeness of this report, the tests conducted and the correctness of the report contents. Unless specific mention, the uncertainty of measurement has been explicitly taken into account to declare the compliance or non-compliance to the specification. The report must not be used by the client to claim product certification, approval, or endorsement by A2LA or any government agencies.

## Table of Contents

<b>Release Control Record .....</b>	<b>3</b>
<b>1 Certificate of Conformity .....</b>	<b>4</b>
<b>2 Summary of Test Results .....</b>	<b>5</b>
2.1 Measurement Uncertainty .....	5
2.2 Modification Record .....	5
<b>3 General Information .....</b>	<b>6</b>
3.1 General Description of EUT .....	6
3.2 Description of Test Modes .....	7
3.2.1 Test Mode Applicability and Tested Channel Detail .....	8
3.3 Description of Support Units .....	9
3.3.1 Configuration of System under Test .....	9
<b>4 Test Types and Results .....</b>	<b>11</b>
4.1 Radiated Emission Measurement .....	11
4.1.1 Limits of Radiated Emission Measurement .....	11
4.1.2 Test Instruments .....	12
4.1.3 Test Procedures .....	13
4.1.4 Deviation from Test Standard .....	14
4.1.5 Test Setup .....	14
4.1.6 EUT Operating Conditions .....	16
4.1.7 Test Results .....	17
4.2 Conducted Emission Measurement .....	19
4.2.1 Limits of Conducted Emission Measurement .....	19
4.2.2 Test Instruments .....	19
4.2.3 Test Procedures .....	20
4.2.4 Deviation from Test Standard .....	20
4.2.5 Test Setup .....	20
4.2.6 EUT Operating Conditions .....	20
4.2.7 Test Results .....	21
<b>5 Pictures of Test Arrangements .....</b>	<b>23</b>
<b>Appendix – Information on the Testing Laboratories .....</b>	<b>24</b>

### Release Control Record

Issue No.	Description	Date Issued
FCC_IC_SL18121801-KLA-021-Co-location	Original release	02/24/2020
FCC_IC_SL18121801-KLA-021-Co-location Rev_1.0	Add Conducted Emission Test Result	02/28/2020

## 1 Certificate of Conformity

**Product:** SensArray@Automation FOUP  
**Brand:** KLA  
**Test Model:** AF120  
**Series Model:** N/A  
**Sample Status:** Engineering Sample  
**Applicant:** KLA Corporation  
**Test Date:** 03/13/2019 and 02/21/2020  
**Standards:** 47 CFR FCC Part 15, Subpart C (Section 15.247)  
ANSI C63.10: 2013

The above equipment has been tested by **Bureau Veritas Consumer Products Services, Inc. Milpitas Branch**, and found compliance with the requirement of the above standards. The test record, data evaluation & Equipment Under Test (EUT) configurations represented herein are true and accurate accounts of the measurements of the sample's EMC characteristics under the conditions specified in this report.

**Prepared by :**  \_\_\_\_\_, **Date:** 02/28/2020  
Yao-Wei Lee/ Test Engineer

**Approved by :**  \_\_\_\_\_, **Date:** 02/28/2020  
Chen Ge / Engineer Reviewer

## 2 Summary of Test Results

47 CFR FCC Part 15, Subpart C (Section 15.247)			
FCC Clause	Test Item	Result	Remarks
15.207	AC Power Conducted Emission	PASS	Meet the requirement of limit.
15.205 / 15.209 / 15.247(d)	Radiated Emissions Measurement	PASS	Meet the requirement of limit.
15.247(d)	Antenna Port Emission	PASS	N/A
15.247(a)(2)	6dB bandwidth	PASS	N/A
15.247(b)	Conducted power	PASS	N/A
15.247(e)	Power Spectral Density	PASS	N/A
15.203	Antenna Requirement	PASS	Antenna is chip antenna (The device is professionally installed)

### 2.1 Measurement Uncertainty

Where relevant, the following measurement uncertainty levels have been estimated for tests performed on the EUT as specified in CISPR 16-4-2:

Measurement	Frequency	Expanded Uncertainty (k=2) (±)
Conducted Emissions at mains ports	150kHz ~ 30MHz	3.51dB
Radiated Emissions up to 1 GHz	30MHz ~ 1GHz	3.73dB
Radiated Emissions above 1 GHz	1GHz ~ 6GHz	4.64dB
	6GHz ~ 18GHz	4.82dB
	18GHz ~ 40GHz	4.91dB

### 2.2 Modification Record

There were no modifications required for compliance.

### 3 General Information

#### 3.1 General Description of EUT

Product	SensArray®Automation FOUP
WiFi Module	Single Board Computer (Raspberry Pi 3 Model B+)
Brand	KLA
Test Model	AF120
2.4GHz WiFi Module Model	Raspberry Pi 3 Model B+
Series Model	N/A
Model Difference	N/A
Status of EUT	Engineering Sample
Power Supply Rating	100-240VAC, 1.2A, 50-60Hz
Modulation Type	CCK, DQPSK
Modulation Technology	DSSS, OFDM
Transfer Rate	802.11b: up to 11Mbps 802.11g: up to 54Mbps 802.11n: up to 300Mbps
Operating Frequency	2.412 ~ 2.462GHz
Number of Channel	11 for 802.11b, 802.11g, 802.11n (HT20)
Antenna Type	Chip Antenna for 2.4G Band
Antenna Connector	N/A

Note:

1. The above EUT information is declared by manufacturer and for more detailed features description, please refer to the manufacturer's specifications or user's manual.
2. Bluetooth and 5GHz WiFi are disabled on the Raspberry Pi 3 Model B+ (FCC ID: 2ABCB-RPI3BP). Only 2.4GHz WiFi is active and co-locating.

### 3.2 Description of Test Modes

11 channels are provided for 802.11b, 802.11g and 802.11n (HT20):

Channel	Frequency	Channel	Frequency
1	2412MHz	7	2442MHz
2	2417MHz	8	2447MHz
3	2422MHz	9	2452MHz
4	2427MHz	10	2457MHz
5	2432MHz	11	2462MHz
6	2437MHz		

### 3.2.1 Test Mode Applicability and Tested Channel Detail

EUT CONFIGURE MODE	APPLICABLE TO				DESCRIPTION
	RE $\geq$ 1G	RE<1G	PLC	APCM	
-	√	√	-	-	-

Where RE $\geq$ 1G: Radiated Emission above 1GHz & Bandedge Measurement  
 RE<1G: Radiated Emission below 1GHz  
 PLC: Power Line Conducted Emission  
 APCM: Antenna Port Conducted Measurement

**NOTE:** The EUT had been pre-tested on the positioned of each 3 axis. The worst case was found when positioned on **Y-plane**.

**NOTE:** "-" means no effect.

#### Test Condition:

APPLICABLE TO	ENVIRONMENTAL CONDITIONS	INPUT POWER	TESTED BY
RE $\geq$ 1G	25deg. C, 65%RH	120Vac, 60Hz	Yaowei Lee
RE<1G	25deg. C, 65%RH	120Vac, 60Hz	Yaowei Lee
PLC	25deg. C, 68%RH	120Vac, 60Hz	-
APCM	21deg. C, 60%RH	120Vac, 60Hz	-



### 3.3 Description of Support Units

The EUT has been tested as an independent unit together with other necessary accessories or support units. The following support units or accessories were used to form a representative test configuration during the tests.

ID	Product	Brand	Model No.	Serial No.	FCC ID	Remarks
A.	-	-	-	-	-	-
B.						
C.						
D.						
E.						
F.						
G.						

ID	Descriptions	Qty.	Length (m)	Shielding (Yes/No)	Cores (Qty.)	Remarks
1.	-	-	-	-	-	-
2.						
3.						

Note: The core(s) is(are) originally attached to the cable(s).

#### 3.3.1 Configuration of System under Test

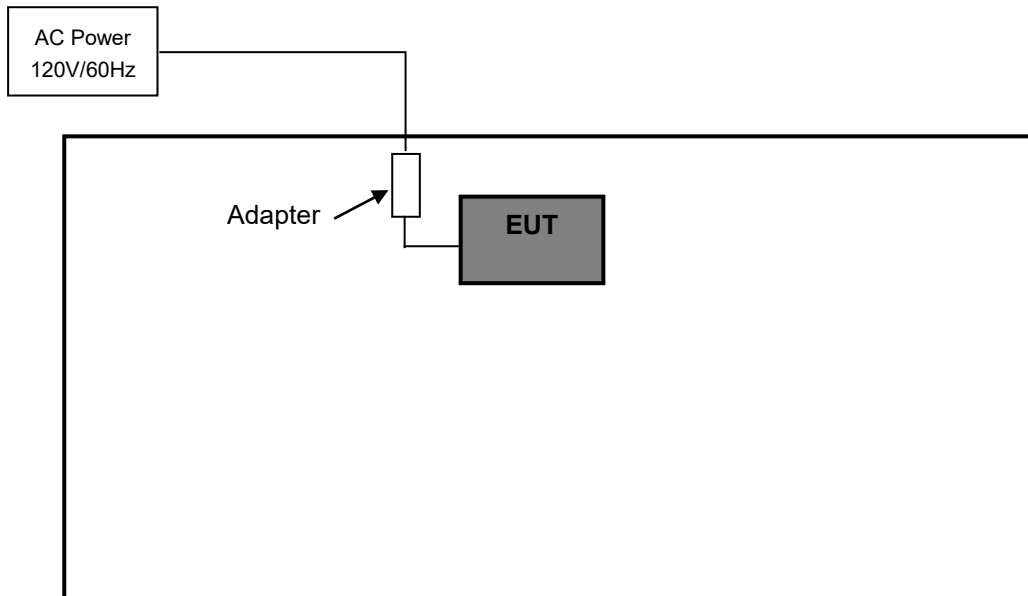

Non-Conductive Table

## GENERAL DESCRIPTION OF APPLIED STANDARDS

The EUT is a RF Product. According to the specifications of the manufacturer, it must comply with the requirements of the following standards:

**47 CFR FCC Part 15, Subpart C (Section 15.247)**  
**RSS 247 Issue2, February 2017**  
**RSS Gen Issue5, March 2019**  
**KDB 558074 D01 15.247 Meas Guidance v05r01**  
**KDB 662911 D01 Multiple Transmitter Output v02r01**  
**ANSI C63.10-2013**

All test items have been performed and recorded as per the above standards.

## 4 Test Types and Results

### 4.1 Radiated Emission Measurement

#### 4.1.1 Limits of Radiated Emission Measurement

Radiated emissions which fall in the restricted bands must comply with the radiated emission limits specified as below table. Other emissions shall be at least 20dB (power peak measurement) or 30dB (power Ave.measurement) below the highest level of the desired power:

Frequencies (MHz)	Field Strength (microvolts/meter)	Measurement Distance (meters)
0.009 ~ 0.490	2400/F(kHz)	300
0.490 ~ 1.705	24000/F(kHz)	30
1.705 ~ 30.0	30	30
30 ~ 88	100	3
88 ~ 216	150	3
216 ~ 960	200	3
Above 960	500	3

**NOTE:**

1. The lower limit shall apply at the transition frequencies.
2. Emission level (dBuV/m) = 20 log Emission level (uV/m).
3. For frequencies above 1000MHz, the field strength limits are based on average detector, however, the peak field strength of any emission shall not exceed the maximum permitted average limits, specified above by more than 20dB under any condition of modulation.

## 4.1.2 Test Instruments

DESCRIPTION & MANUFACTURER	MODEL NO.	SERIAL NO.	DATE OF CALIBRATION	DUE DATE OF CALIBRATION
50GHz Spectrum Analyzer	N9030B (PXA)	MY57140597	06/05/2019	06/05/2020
Biconilog Antenna Sunol	JB1	A030702	03/09/2018	03/09/2020
Pre-Amplifier RF Bay, Inc.	LPA-6-30	11170601	04/27/2019	04/27/2020
Horn Antenna ETS-Lindgren	3117	218554	11/20/2019	11/20/2020
Pre-Amplifier RF-Lambda	RAMP00M50GA	17032300048	06/18/2019	06/18/2020

#### 4.1.3 Test Procedures

##### **For Radiated emission below 30MHz**

- a. The EUT was placed on the top of a rotating table 0.8 meters above the ground at a 3 meter chamber room. The table was rotated 360 degrees to determine the position of the highest radiation.
- b. The EUT was set 3 meters away from the interference-receiving antenna, which was mounted on the top of a variable-height antenna tower.
- c. Parallel, perpendicular, and ground-parallel orientations of the antenna are set to make the measurement.
- d. For each suspected emission, the EUT was arranged to its worst case and the rotatable table was turned from 0 degrees to 360 degrees to find the maximum reading.
- e. The test-receiver system was set to Quasi-Peak Detect Function and Specified Bandwidth with Maximum Hold Mode.

##### **NOTE:**

1. The resolution bandwidth and video bandwidth of test receiver/spectrum analyzer is 9kHz at frequency below 30MHz.

##### **For Radiated emission above 30MHz**

- a. The EUT was placed on the top of a rotating table 0.8 meters (for 30MHz ~ 1GHz) / 1.5 meters (for above 1GHz) above the ground at 3 meter chamber room for test. The table was rotated 360 degrees to determine the position of the highest radiation.
- b. The EUT was set 3 meters away from the interference-receiving antenna, which was mounted on the top of a variable-height antenna tower.
- c. The height of antenna is varied from one meter to four meters above the ground to determine the maximum value of the field strength. Both horizontal and vertical polarizations of the antenna are set to make the measurement.
- d. For each suspected emission, the EUT was arranged to its worst case and then the antenna was tuned to heights from 1 meter to 4 meters and the rotatable table was turned from 0 degrees to 360 degrees to find the maximum reading.
- e. The test-receiver system was set to quasi-peak detect function and specified bandwidth with maximum hold mode when the test frequency is below 1 GHz.
- f. The test-receiver system was set to peak and average detects function and specified bandwidth with maximum hold mode when the test frequency is above 1 GHz. If the peak reading value also meets average limit, measurement with the average detector is unnecessary.

##### **Note:**

1. The resolution bandwidth and video bandwidth of test receiver/spectrum analyzer is 120kHz for Quasi-peak detection (QP) at frequency below 1GHz.
2. The resolution bandwidth of test receiver/spectrum analyzer is 1 MHz and the video bandwidth is 3 MHz for Peak detection (PK) at frequency above 1GHz.
3. The resolution bandwidth of test receiver/spectrum analyzer is 1MHz and the video bandwidth is  $\geq 1/T$  (Duty cycle < 98%) or 10Hz (Duty cycle  $\geq 98\%$ ) for Average detection (AV) at frequency above 1GHz.
4. All modes of operation were investigated and the worst-case emissions are reported.

4.1.4 Deviation from Test Standard

No deviation.

4.1.5 Test Setup

**For Radiated emission below 30MHz**

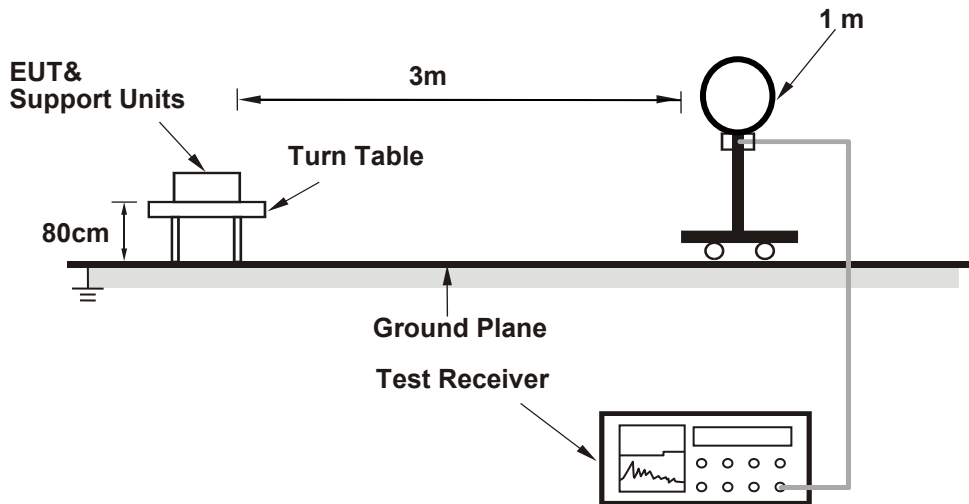

**For Radiated emission 30MHz to 1GHz**

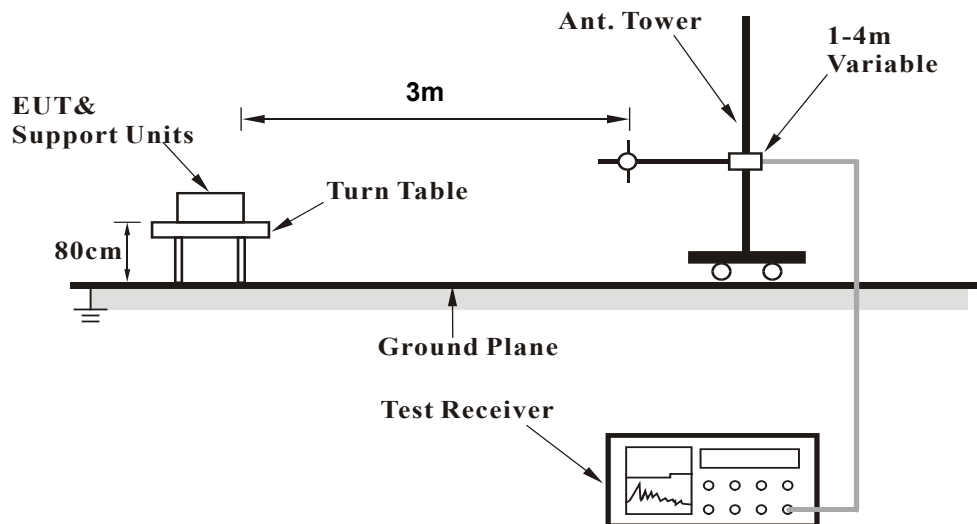

**For Radiated emission above 1GHz**

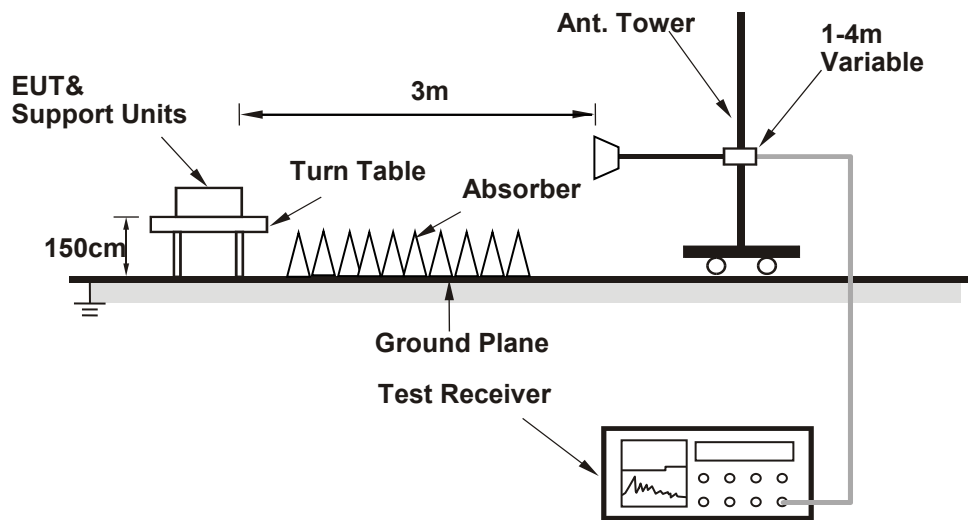

For the actual test configuration, please refer to the attached file (Test Setup Photo).

#### 4.1.6 EUT Operating Conditions

- a. Placed the EUT on the testing table.
- b. Prepared notebooks to act as communication partner and placed it outside of testing area.
- c. The communication partner connected with EUT via a RJ45 cable and ran a test program (provided by manufacturer) to enable EUT under transmission condition continuously at specific channel frequency.
- d. The communication partner sent data to EUT by command "PING".
- e. The necessary accessories enable the system in full functions.



4.1.7 Test Results

**BELOW 1GHz WORST-CASE DATA:**

<b>CHANNEL</b>	2.4G/2.4G transmit simultaneous mode	<b>DETECTOR FUNCTION</b>	Quasi Peak
<b>FREQUENCY RANGE</b>	30MHz – 1GHz		

Antenna Polarity & Test Distance: Vertical and Horizontal at 3m										
No.	Frequency (MHz)	Polarization (H/V)	Reading QP [dB(uV)]	Factor [dB(1/m)]	Level QP [dB(uV/m)]	LimitQP dB(uV/m)	Margin QP [dB]	Height (cm)	Angle (Deg)	Pass/Fail
1	210.3	H	24.8	17.1	41.9	43.5	1.6	165	87.3	Pass
2	102.133	V	24.8	16.5	41.3	43.5	2.2	99.8	15.8	Pass
3	386.653	V	17.7	22.5	40.2	46	5.8	120	93.2	Pass
4	248.947	H	21	18	39	46	7	122	101	Pass
5	283.548	H	12.9	20.7	33.6	46	12.4	99.7	103	Pass
6	133.856	V	23.9	19.5	43.4	43.5	0.1	99.8	0	Pass

**REMARKS:**

1. Emission level (dBuV/m) = Raw Value (dBuV) + Cable Loss (dB) + AF (dB)
2. AF (dB/m) = Antenna Factor (dB/m) – Preamplifier Gain (dB).
3. The emission levels of other frequencies were less than 20dB margin against the limit.
4. Margin value = Emission level – Limit value.

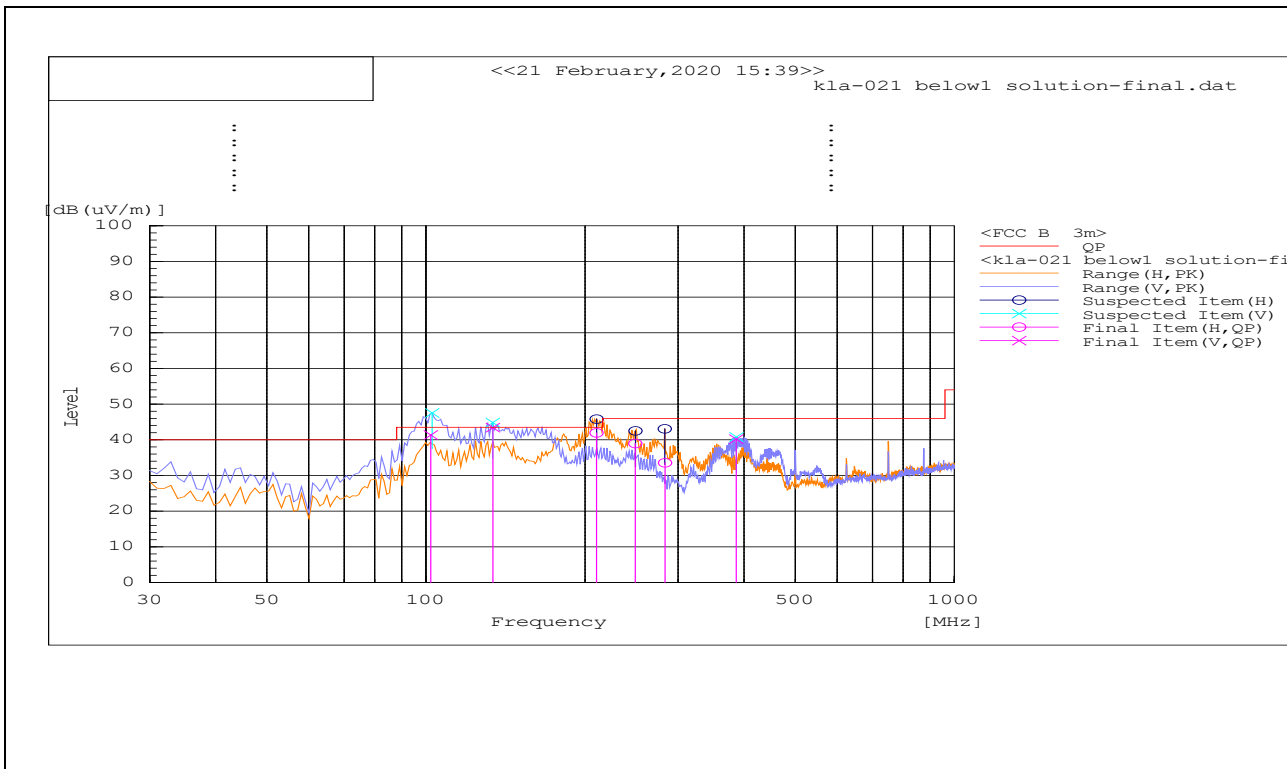

### Above 1GHz Test Data:

#### Above 1GHz-25GHz – Co-location

Antenna Polarity & Test Distance: Vertical and Horizontal at 3m														
No.	Frequency (MHz)	Polarization (H/V)	Reading AV [dB(uV)]	Reading PK [dB(uV)]	Factor [dB(1/m)]	Level AV [dB(uV/m)]	Level PK dB(uV/m)	Limit\AV dB(uV/m)	Limit\PK [dB(uV/m)]	Margin AV [dB]	Margin PK [dB]	Height (cm)	Angle (Deg)	Pass/ Fail
1	1493.20	V	44.2	54.4	-15.8	28.4	38.6	54	74	25.6	35.4	307	30.6	Pass
2	1917.52	H	44.5	53.8	-11	33.5	42.8	54	74	20.5	31.2	251	280	Pass
3	2614.92	H	44	54.1	-9.1	34.9	45	54	74	19.1	29	323	218	Pass
4	6983.73	H	34	43.8	4.9	38.9	48.7	54	74	15.1	25.3	227	255	Pass
5	13409.52	V	29.1	38.5	12.9	42	51.4	54	74	12	22.6	350	24.5	Pass

## 4.2 Conducted Emission Measurement

### 4.2.1 Limits of Conducted Emission Measurement

Frequency (MHz)	Conducted Limit (dBuV)	
	Quasi-peak	Average
0.15 - 0.5	66 - 56	56 - 46
0.50 - 5.0	56	46
5.0 - 30.0	60	50

- Note: 1. The lower limit shall apply at the transition frequencies.  
 2. The limit decreases in line with the logarithm of the frequency in the range of 0.15 to 0.50MHz.

### 4.2.2 Test Instruments

Description & Manufacturer	Model No.	Serial No.	Date Of Calibration	Due Date Of Calibration
EMI Test Receiver ROHDE & SCHWARZ	ESIB 40	100179	08/28/2018	08/28/2019
Transient Limiter ELECTRO-METRICS	EM-7600-5	106	12/31/2018	12/31/2019
LISN EMCO	3816/2NM	214372	01/10/2019	01/10/2020

#### 4.2.3 Test Procedures

- The EUT was placed 0.4 meters from the conducting wall of the shielded room with EUT being connected to the power mains through a line impedance stabilization network (LISN). Other support units were connected to the power mains through another LISN. The two LISNs provide 50 ohm/ 50uH of coupling impedance for the measuring instrument.
- Both lines of the power mains connected to the EUT were checked for maximum conducted interference.
- The frequency range from 150 kHz to 30MHz was searched. Emission levels under (Limit - 20dB) was not recorded.

**NOTE:** The resolution bandwidth and video bandwidth of test receiver is 9 kHz for quasi-peak detection (QP) and average detection (AV) at frequency 0.15MHz-30MHz.

#### 4.2.4 Deviation from Test Standard

No deviation.

#### 4.2.5 Test Setup

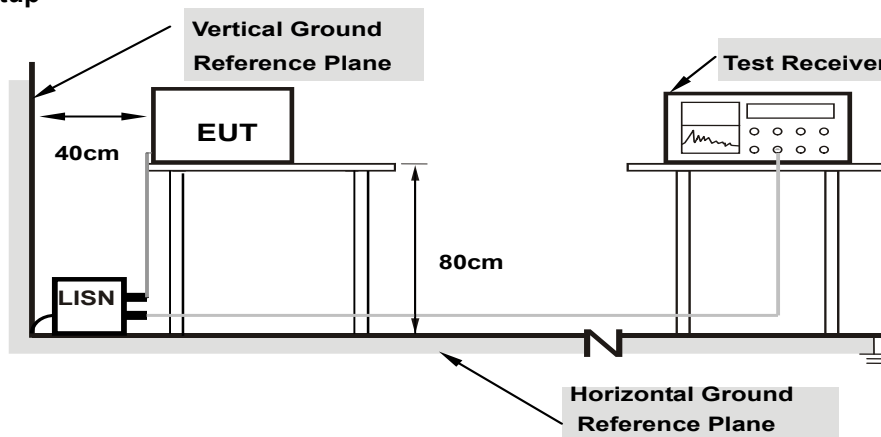

**Note:** 1.Support units were connected to second LISN.

For the actual test configuration, please refer to the attached file (Test Setup Photo).

#### 4.2.6 EUT Operating Conditions

Same as 4.1.6.

### 4.2.7 Test Results

Phase		Live (L)				Detector Function		Quasi-Peak / Average		
No	Freq. [MHz]	Raw (dBuV)	Calc Loss (dB)	Factors (dB)	Level (dBuV)	Measurement Type	Line	Limit (dBuV)	Margin (dB)	Pass /Fail
1	0.186048	43.03	7.15	0.04	50.23	Quasi Peak	Live	79	-28.77	Pass
2	0.15	39.12	7.11	0.05	46.28	Quasi Peak	Live	79	-32.72	Pass
3	29.84261	26.9	9.05	0.61	36.56	Quasi Peak	Live	73	-36.44	Pass
4	17.13873	21.95	8.97	0.41	31.33	Quasi Peak	Live	73	-41.67	Pass
5	0.26709	33.04	7.23	0.04	40.3	Quasi Peak	Live	79	-38.7	Pass
6	16.55223	22.7	8.96	0.39	32.06	Quasi Peak	Live	73	-40.94	Pass
7	0.186048	22.83	7.15	0.04	30.03	Average	Live	66	-35.97	Pass
8	0.15	21.48	7.11	0.05	28.64	Average	Live	66	-37.36	Pass
9	29.84261	25.99	9.05	0.61	35.65	Average	Live	60	-24.35	Pass
10	17.13873	16.32	8.97	0.41	25.7	Average	Live	60	-34.3	Pass
11	0.26709	16.05	7.23	0.04	23.32	Average	Live	66	-42.68	Pass
12	16.55223	16.02	8.96	0.39	25.38	Average	Live	60	-34.62	Pass

#### REMARKS:

1. The emission levels of other frequencies were very low against the limit.
2. Margin value = Emission level - Limit value
3. Emission Level = Correction Factor + Raw Value + Factors Value.

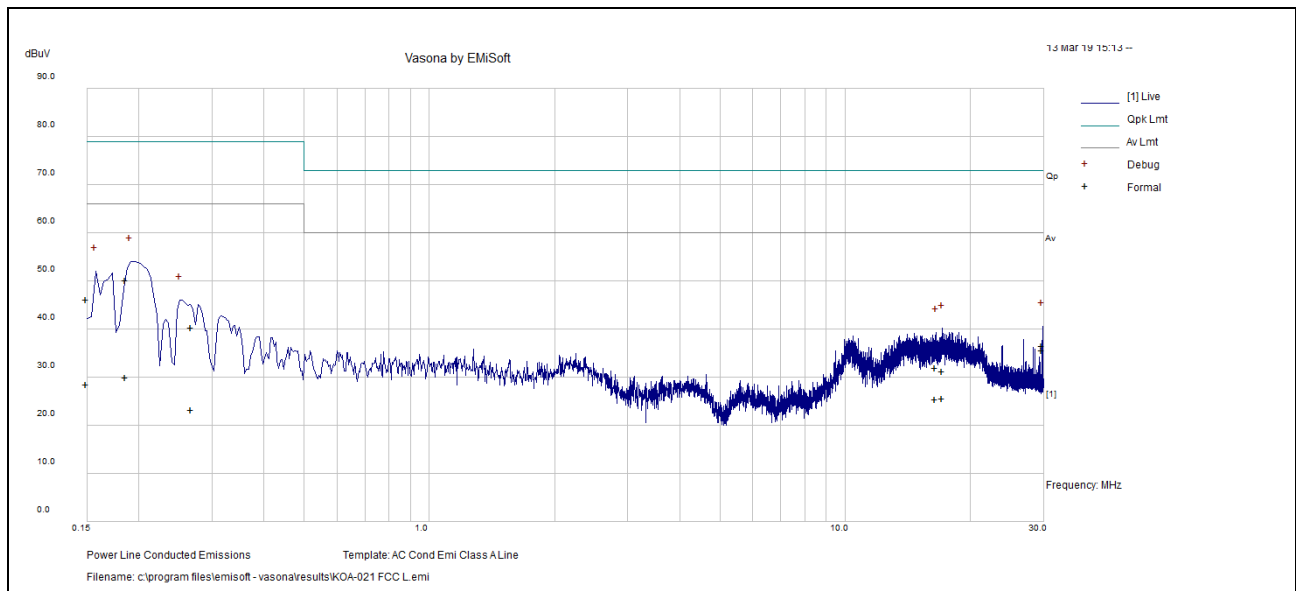

Phase	Neutral (N)	Detector Function	Quasi-Peak / Average
-------	-------------	-------------------	----------------------

No	Freq.	Raw	Cale Loss	Factors	Level	Measurement Type	Line	Limit	Margin	Pass /Fail
	[MHz]	(dBuV)	(dB)	(dB)	(dBuV)			(dBuV)	(dB)	
1	0.199623	40.13	7.17	0.04	47.34	Quasi Peak	Neutral	79	-31.66	Pass
2	0.150288	37.45	7.11	0.04	44.61	Quasi Peak	Neutral	79	-34.39	Pass
3	29.84174	27.52	9.05	0.86	37.44	Quasi Peak	Neutral	73	-35.56	Pass
4	17.15387	23.04	8.97	0.39	32.4	Quasi Peak	Neutral	73	-40.6	Pass
5	10.25603	21.86	8.42	0.26	30.54	Quasi Peak	Neutral	73	-42.46	Pass
6	10.07883	22.01	8.34	0.25	30.6	Quasi Peak	Neutral	73	-42.4	Pass
7	0.199623	23.28	7.17	0.04	30.48	Average	Neutral	66	-35.52	Pass
8	0.150288	22.27	7.11	0.04	29.42	Average	Neutral	66	-36.58	Pass
9	29.84174	26.63	9.05	0.86	36.55	Average	Neutral	60	-23.45	Pass
10	17.15387	16.82	8.97	0.39	26.18	Average	Neutral	60	-33.82	Pass
11	10.25603	15.8	8.42	0.26	24.48	Average	Neutral	60	-35.52	Pass
12	10.07883	14.28	8.34	0.25	22.87	Average	Neutral	60	-37.13	Pass

**REMARKS:**

1. The emission levels of other frequencies were very low against the limit.
2. Margin value = Emission level - Limit value
3. Emission Level = Correction Factor + Raw Value + Factors Value.

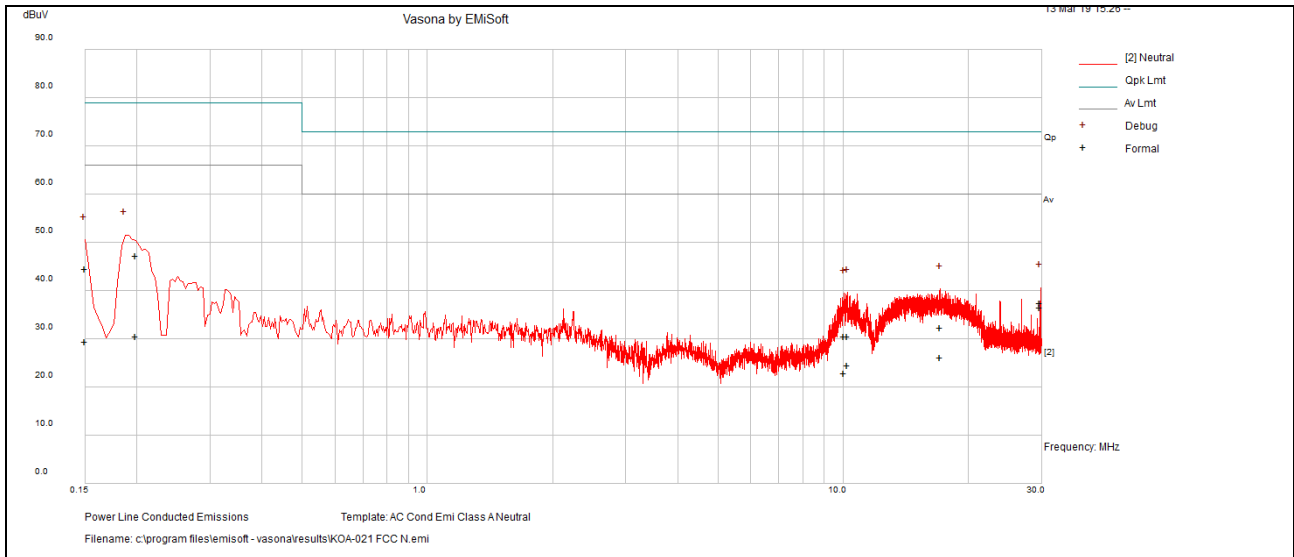

## 5 Pictures of Test Arrangements

Please refer to the attached file (Test Setup Photo).

## Appendix – Information on the Testing Laboratories

Bureau Veritas is a global leader in testing, inspection and certification (TIC) services. We help businesses improve safety, sustainability and productivity; and our clients include the majority of leading brands in retail, manufacturing and other industries. With a presence in every major country around the world, our quality assurance and compliance solutions are vital in helping our customers enhance product quality and concept-to-consumer journeys. We also assist with increasing speed to market, profitability and brand equity throughout the supply chain. Bureau Veritas is a leading wireless/IoT testing, inspection, audit and certification provider, with a global network of test laboratories to support the IoT industry in areas of connectivity, security, interoperability as well as quality, health & safety, and environmental/chemical requirements.

If you have any comments, please feel free to contact us at the following:

**Milpitas EMC/RF/Safety/Telecom Lab**

775 Montague Expressway, Milpitas, CA 95035  
Tel: +1 408 526 1188

**Sunnyvale OTA/Bluetooth Lab**

1293 Anvilwood Avenue, Sunnyvale, CA  
94089  
Tel: +1 669 600 5293

**Littleton EMC/RF/Safety/Environmental Lab**

1 Distribution Center Cir #1, Littleton, MA 01460  
Tel: +1 978 486 8880

**Irvine OTA/PTCRB/Bluetooth/V2X Lab**

15 Musick, Irvine, CA 92618  
Tel: +1 949 716 6512

**Email:** [sales.eaw@us.bureauveritas.com](mailto:sales.eaw@us.bureauveritas.com)

**Web Site:** [www.cpsusa-bureauveritas.com](http://www.cpsusa-bureauveritas.com)

The address and road map of all our labs can be found in our web site also.

--- END ---