



# Test Report

**Applicant:** ENPING KARSECT ELECTRONIC CO., LTD  
**Address of Applicant:** No.32, Xiping North Road, Enping City, Guangdong, China  
**Equipment Under Test (EUT):**  
EUT Name: Wireless Microphone  
Model No.: PT-400  
Trade Mark: NA  
Serial No.: Not supplied by client  
**Standards:** FCC PART 74H:2008  
**Date of Receipt:** Jul. 12, 2009  
**Date of Test:** Jul. 14 to 20, 2009  
**Date of Issue:** Aug 10, 2009  
**Test Result :** **PASS\***

\* In the configuration tested, the EUT complied with the standards specified above.

Authorized Signature:

Henly Xie / Manager

This report refers to the General Conditions for Inspection and Testing Services, printed overleaf

This report details the results of the testing carried out on one sample. The results contained in this test report do not relate to other samples of the same product. The manufacturer should ensure that all products in series production are in conformity with the product sample detailed in this report.

This report may only be reproduced and distributed in full. If the product in this report is used in any configuration other than that detailed in the report, the manufacturer must ensure the new system complies with all relevant standards.

The report must not be used by the client to claim product certification, approval, or endorsement by NVLAP, NIST, or any agency of the federal government.

All test results in this report can be traceable to National or International Standards.

The test report prepared by:

Guangzhou Huesent Testing Service Co.,Ltd.

Self-ordained 68# courtyard, No.91, Dongguanhuang Road, Guangzhou, China.

Tel: 86-20-28263298 Fax: 86-20-28263237

<http://www.hst.org.cn> E-mail: [hst@hst.org.cn](mailto:hst@hst.org.cn)



## Contents

1	TEST SUMMARY.....	3
2	GENERAL INFORMATION.....	4
2.1	CLIENT INFORMATION.....	4
2.2	GENERAL DESCRIPTION OF E.U.T.....	4
2.3	DETAILS OF E.U.T.....	4
2.4	DESCRIPTION OF SUPPORT UNITS .....	4
2.5	STANDARDS APPLICABLE FOR TESTING.....	4
2.6	TEST LOCATION .....	5
2.7	DEVIATION FROM STANDARDS .....	5
2.8	ABNORMALITIES FROM STANDARD CONDITIONS.....	5
3	EQUIPMENTS USED DURING TEST .....	6
4	TEST RESULTS .....	7
4.1	E.U.T. OPERATION CONDITION.....	7
4.2	TEST PROCEDURE & MEASUREMENT DATA .....	8
4.2.1	<i>Carrier Radiated Power &amp; Radiated Spurious Emissions.....</i>	8
4.2.2	<i>Occupied Bandwidth .....</i>	11
4.2.3	<i>Frequency Stability .....</i>	14
4.2.4	<i>Modulation Characteristics.....</i>	16
4.3	EUT CONSTRUCTIONAL DETAILS .....	19



## 1 Test Summary

Test	Test Requirement	Standard Paragraph	Result
Carrier Radiated Power	FCC Part 2.1046	74.861 e) 1) 174M-216M--50mW	PASS
Modulation Deviation	FCC Part 2.1047	74.861 e) 3) Within 75kHz	PASS
Frequency Stability	FCC Part 2.1055	74.861 e) 4) <0.005% 50 ppm	PASS
Operating Bandwidth	FCC Part 2.1049 c)	74.861 e) 5) Within 200kHz	PASS
Unwanted Radiation	FCC Part 2.1049 c)	74.861 e) 6) within the mask	PASS
Radiated Spurious Emission	FCC Part 2.1053	74.861 d) 3) < 43+10lgP(W) dB	PASS

Remark:

♣The EUT has one channel, which is located in the range 614.0MHz to 698.0MHz.

Only test result of three samples in 614.2 MHz, 655.8 MHz and 697.8 MHz were recorded in this report.



## 2 General Information

### 2.1 Client Information

Applicant: ENPING KARSECT ELECTRONIC CO., LTD  
Address of Applicant: No.32, Xinping North Road, Enping City, Guangdong, China

### 2.2 General Description of E.U.T.

EUT Name: Wireless Microphone  
Item No.: PT-400;  
Serial No.: Not supplied by client

### 2.3 Details of E.U.T.

Power Supply: 3Vdc, 2 x AA size Battery  
Main Function: Wireless microphone system with an associated receiver for transmitting voice.

The final amplifier Collector Voltage and Collector Current are 0.3V & 3.5mA respectively.

Necessary Bandwidth:  $2M+2DK= 2 \times 25kHz + 2 \times 20kHz \times 1.0 = 90 \text{ kHz}$

### 2.4 Description of Support Units

Connect the EUT to mains power, and then test the EUT with signal generator.

### 2.5 Standards Applicable for Testing

The standard used was FCC PART 74H, 2008

The EUT belongs to licensed low power auxiliary devices.



## 2.6 Test Location

GuangZhou Huesent Testing Service Co., Ltd.  
No.91, Dongguanzhuang Road, Guangzhou, China.  
Tel: 86-20-87221905, Fax: 86-20-87223892  
CNAS- Accreditation No.: L2885.  
CMA- Authorisation Certificate No.: 2008191614Z

ERP & Spurious Emission tests were subcontracted to the laboratory following-

CEPREI (headquarters) lab.

No.110, Dongguanzhuang Road, Tianhe District, Guangzhou city, Guangdong Province,  
P.R. China

Tel: 86-20-87237178 Fax: 86-20-87236171 Email: [emc@ceprei.biz](mailto:emc@ceprei.biz)

FCC- Registration No: 258518 on Mar 25, 2008

## 2.7 Deviation from Standards

None.

## 2.8 Abnormalities from Standard Conditions

None.



### 3 Equipments Used during Test

No.	Test item.	Name of Equipment's	Model/Type	Last Calibrated Date
1	CE	EMI receiver	R&S ESCS 30	2009-6-8
2	CE	LISN	R&S ESH2-Z5	2009-6-8
3	CE	Shielded room	Lindgren 8*5*3	2008-6-8
4	RE	EMI RECEIVER	R&S ESU	2009-6-8
5	RE	Anechoic chamber	Lindgren FACT-4	2008-6-8
6	RE	Antenna	ETS-Lindgren 3142B	2009-6-8
Note: /				



## 4 Test Results

### 4.1 E.U.T. Operation Condition

Operating Environment:

Temperature: 20.0 °C~25 °C

Humidity: 50 ~70% RH

Atmospheric Pressure: 980~1012 mbar

EUT Operation: Test the EUT in transmitting mode.



## 4.2 Test Procedure & Measurement Data

### 4.2.1 Carrier Radiated Power & Radiated Spurious Emissions

Test Requirement: FCC CFR 47 Part 74.861 e) 1) & d) 3)

Test Method: EIA/TIA 603-C:2004 section 2.2,  
FCC CFR 47 Part 2.1047 & 1053

Test Date: Jul. 14, 2009

Measurement Distance: 3m (Semi-Anechoic Chamber)

Test Requirement:

(d) For low power auxiliary stations operating in the bands other than those allocated for TV broadcasting, the following technical requirements are imposed.

(3) The occupied bandwidth shall not be greater than that necessary for satisfactory transmission and, in any event, an emission appearing on any discrete frequency outside the authorized band shall be attenuated, at least,  $43+10 \log^{10}$  (mean output power, in watts) dB below the mean output power of the transmitting unit.

(e) For low power auxiliary stations operating in the bands allocated for TV broadcasting, the following technical requirements apply:

(1) The power of the measured unmodulated carrier power at the output of the transmitter power amplifier (antenna input power) may not exceed the following:

(i) 54–72, 76–88, and 174–216 MHz bands—50 mW

(ii) 470–608 and 614–806 MHz bands—250 mW

Test Procedure:

The procedure used was EIA/TIA 603-C:2004. The receive was scanned from 30MHz to 5.0GHz. When an emission was found, the table was rotated to produce the maximum signal strength. An initial pre-scan was performed for in peak detection mode using the receiver. The EUT was measured for both the Horizontal and Vertical polarities and performed a pre-test three orthogonal planes.

The field strength is calculated by adding the Antenna Factor, Cable Factor & Peramplifier. The basic equation with a sample calculation is as follows:

Final Test Level = Receiver Reading + Antenna Factor + Cable Factor – Peramplifier Factor

An initial pre-scan was performed in the 3m chamber using the spectrum analyser in peak detection mode. Quasi-peak measurements were conducted based on the peak sweep graph. The EUT was measured by Bilog antenna with 2 orthogonal polarities

Remove the EUT and replace it with substitution antenna. A signal generator was connected to the substitution antenna by a non-radiating cable. The absolute levels of the Carrier Radiated Power and spurious emissions were measured by the substitution.



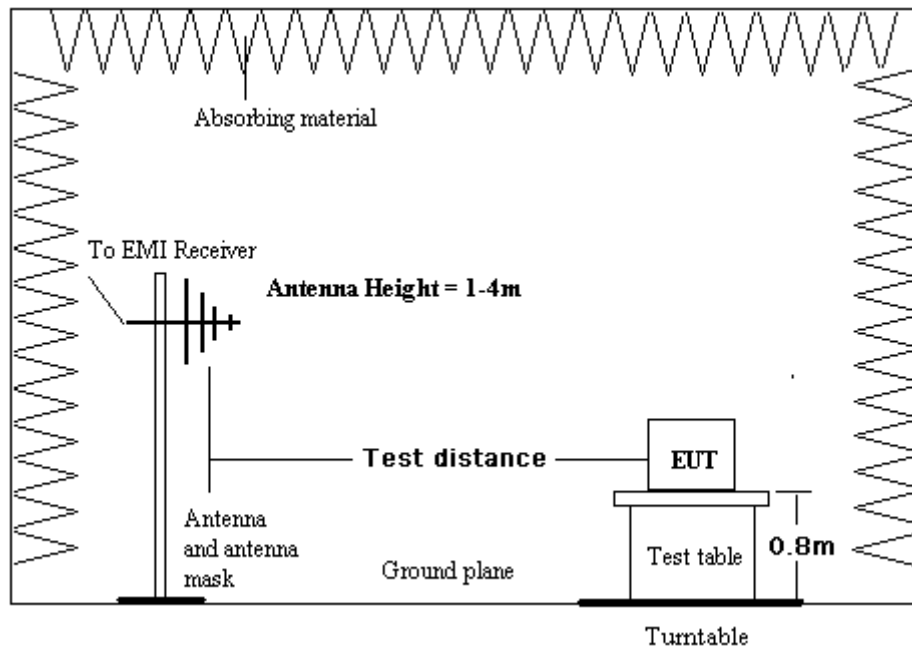

**Test Result:**

Carrier Frequency (MHz)	Factual Level dBm (mW)	Limit in 74.861 e) 1)
614.200	-1.2 dBm(i.e. 0.76mW)	17 dBm (i.e. 50 mW)
655.800	-1.1 dBm(i.e. 0.78mW)	17 dBm (i.e. 50 mW)
697.800	-1.4 dBm(i.e. 0.73mW)	17 dBm (i.e. 50 mW)

The Factual Level is ERP value.



**Radiated spurious emissions:**

614.200 MHz				
Spurious Emission Frequency (MHz)	Factual Level Horizontal (dBm)	Factual Level Vertical (dBm)	Limit (dBm)	Min Margin (dB)
307.400	-60.1	-56.6	-13.0	>40
1229.600	-61.2	-59.9	-13.0	>40
1844.400	NA	NA	-13.0	NA
2459.200	NA	NA	-13.0	NA
3074.000	NA	NA	-13.0	NA
655.800 MHz				
328.000	-59.5	-54.4	-13.0	>40
1312.000	-61.5	-57.1	-13.0	>40
1968.000	NA	NA	-13.0	NA
2624.000	NA	NA	-13.0	NA
3280.000	NA	NA	-13.0	NA
697.800 MHz				
348.900	-58.2	-55.2	-13.0	>40
1395.600	-60.8	-57.0	-13.0	>40
2093.400	NA	NA	-13.0	NA
2791.200	NA	NA	-13.0	NA
3489.000	NA	NA	-13.0	NA

**The Factual Level is ERP value.**

The peak emission of other frequency in rang from 30MHz up to 10 times carrier were 25dB lower than the limit, hence no data was recorded in the report.

**TEST RESULTS: The unit does meet the FCC requirements.**

### 4.2.2 Occupied Bandwidth

Test Requirement: FCC CFR 47 Part 74.e) 5) & 6)

Test Method: FCC CFR 47 Part 2.1049

Test Date: Jul. 20, 2009

Requirements:

(e) For low power auxiliary stations operating in the bands allocated for TV broadcasting, the following technical requirements apply:

(5) The operating bandwidth shall not exceed 200 kHz.

(6) The mean power of emissions shall be attenuated below the mean output power of the transmitter in accordance with the following schedule:

(i) On any frequency removed from the operating frequency by more than 50 percent up to and including 100 percent of the authorized bandwidth: at least 25dB;

(ii) On any frequency removed from the operating frequency by more than 100 percent up to and including 250 percent of the authorized bandwidth: at least 35dB;

(iii) On any frequency removed from the operating frequency by more than 250 percent of the authorized bandwidth: at least  $43+10\log_{10}$  (mean output power in watts) dB.

Test Procedure

Setup

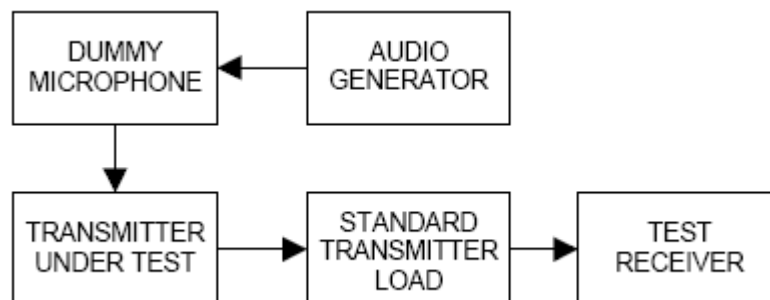

Input 2500Hz signal to the microphone, find the 50% rated deviation, add the level 16dB, test this status the 99% occupied bandwidth and record it.



Test Result: The graph as below, represents the emissions take for this device.  
Occupied Bandwidth ( 99% of total power): 69 kHz.

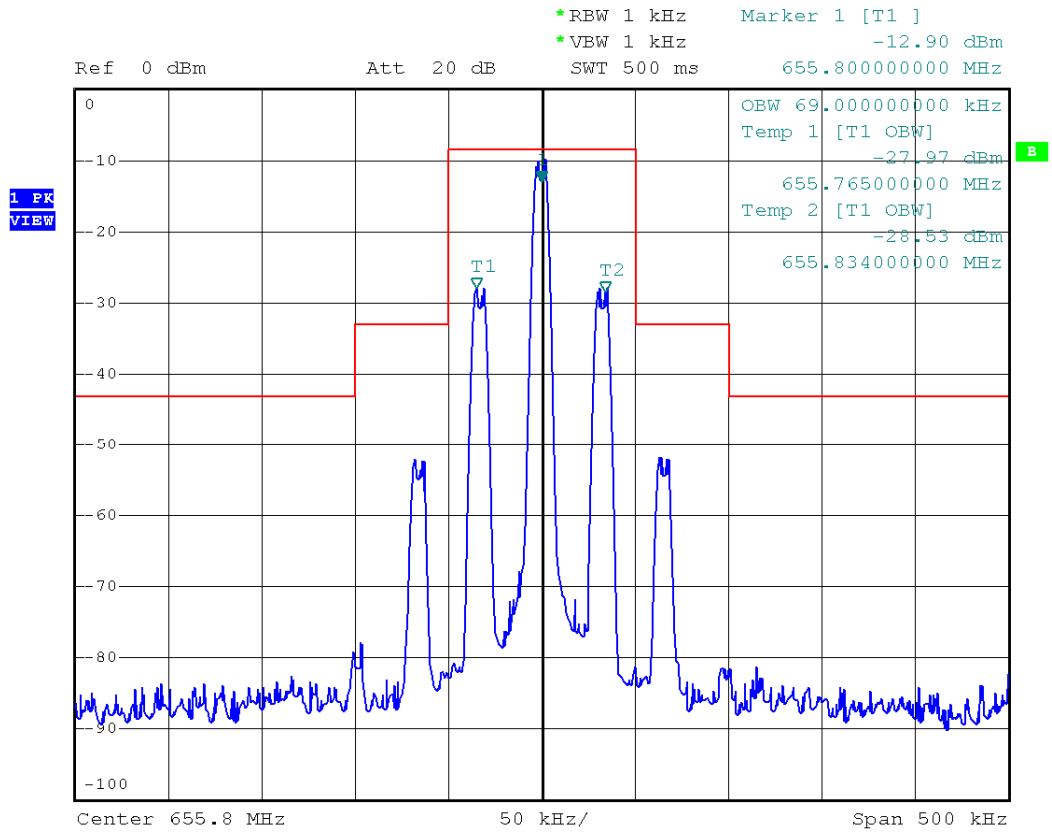



Emission Mask: input with 10 kHz AF, 50% modulation + 16dB.

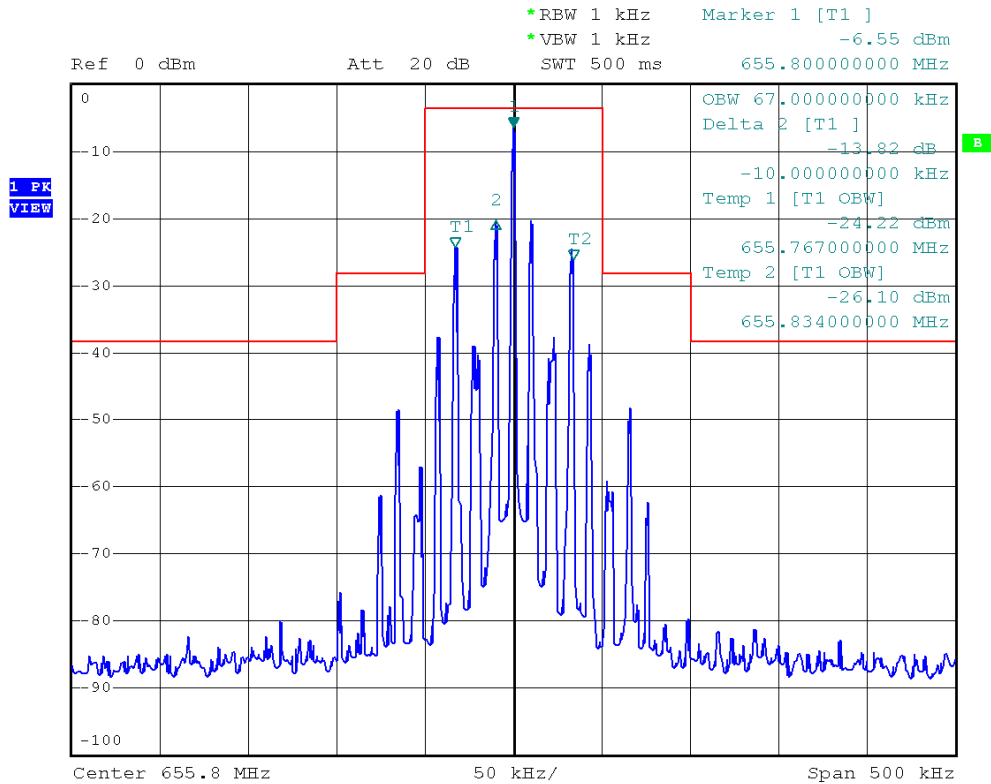

Emission Mask: input with 15 kHz AF, 50% modulation + 16dB.

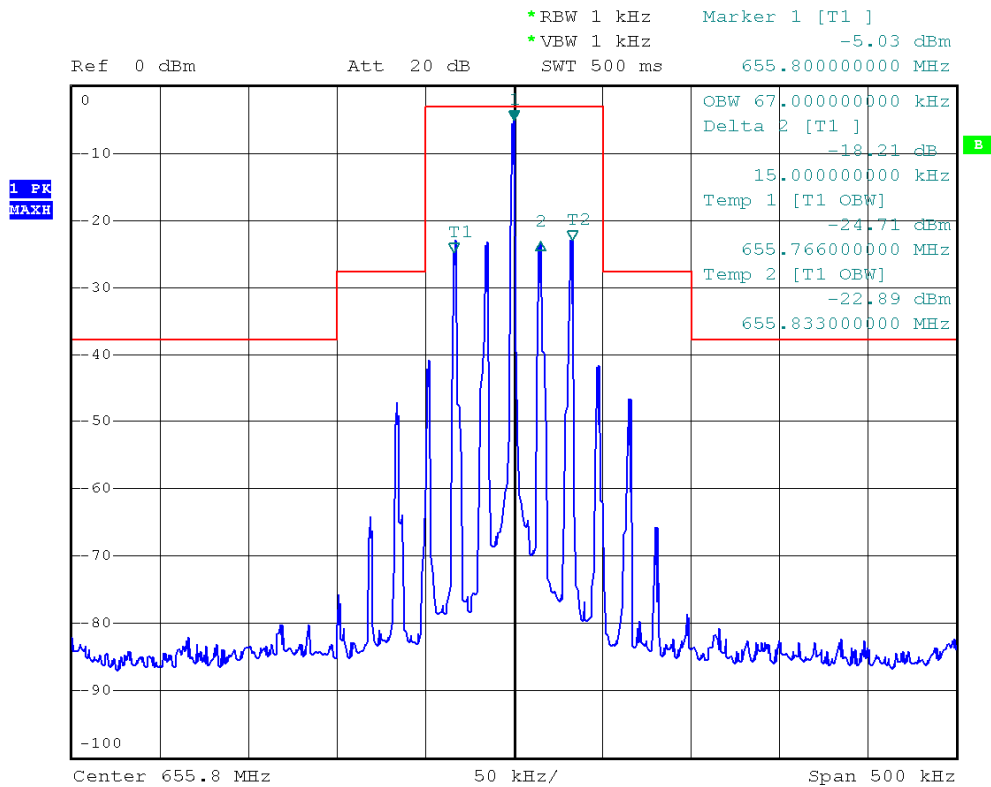

Test results: The unit does meet the FCC requirements.

### 4.2.3 Frequency Stability

Test Requirement: FCC CFR 47 Part 74.e) 4)

Test Method: FCC CFR 47 Part 2.1055

Test Date: Jul. 20, 2009

Requirements: +/-50 ppm

(e) For low power auxiliary stations operating in the bands allocated for TV broadcasting, the following technical requirements apply:

(4) The frequency tolerance of the transmitter shall be 0.005 percent.

#### Test Procedure:

##### Frequency stability versus Environmental Temperature

The equipment under test was connected to an external DC power supply and the RF output was connected to a frequency counter via feed through attenuators. The EUT was placed inside the temperature chamber. After the temperature stabilized for approximately 20 minutes, the frequency of the output signal was recorded from the counter.

##### Frequency Stability versus Input Voltage

At room temperature ( $25 \pm 5^{\circ}\text{C}$ ), an external variable DC power supply was connected to the EUT. The frequency of the transmitter was measured for 115%, 100% and 85% of the nominal operating input voltage. For hand carried, battery powered equipment, reduce primary supply voltage to the battery operating end point which shall be specified by the manufacturer.

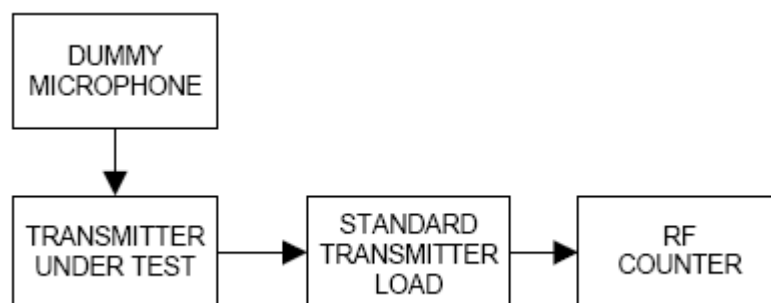



**Test Result:**

Assigned Frequency: 655.800 MHz,		
Environment Temperature (°C)	Power Supplied (Vdc)	Frequency Measure with Time Elapsed Total emission within +/- 32.79 kHz
50	3.0	+28.2
40	3.0	+16.5
30	3.0	+5.8
20	3.0	+0.6
10	3.0	+6.6
0	3.0	+9.1
-10	3.0	+15.3
-20	3.0	+26.0
-30	3.0	+30.2
Environment Temperature (°C)	Power Supplied (Vdc)	Frequency Measure with Time Elapsed Total emission within Max +/- 32.79 kHz
25	3.0	+0.1
25	2.8	-11.5
25	2.6	-26.1

Battery end point: 2.6Vdc

**The results: The unit does meet the FCC requirements.**

#### 4.2.4 Modulation Characteristics

Test Requirement: FCC CFR 47 Part 74.e) 3)

Test Method: FCC CFR 47 Part 2.1047

Test Date: Jul. 20, 2009

Requirements:

(e) For low power auxiliary stations operating in the bands allocated for TV broadcasting, the following technical requirements apply:

(3) Any form of modulation may be used. A maximum deviation of  $\pm 75$  kHz is permitted when frequency modulation is employed.

Test Procedure:

##### Audio Frequency Response

The RF output of the transceiver was connected to the input of FSP 30 with FM deviation module through sufficient attenuation so as not to overload the meter or distort the reading. An audio signal generator was connected to the audio input of microphone.

The audio signal input level was adjusted to obtain **20% of the maximum rated system deviation at 1 kHz**, and recorded as  $DEV_{REF}$ . With the audio signal generator level unchanged, set the generator frequency between 100 to 5000 Hz. The transmitter deviations ( $DEV_{FREQ}$ ) were measured and the audio frequency response was calculated as  $20\log_{10} [DEV_{FREQ} / DEV_{REF}]$

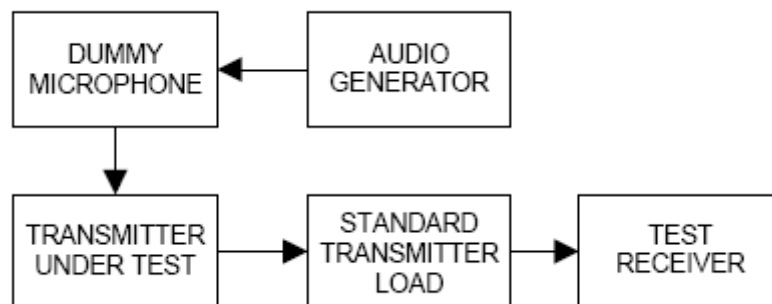



The plot(s) of Audio Frequency Response is presented hereinafter as reference.

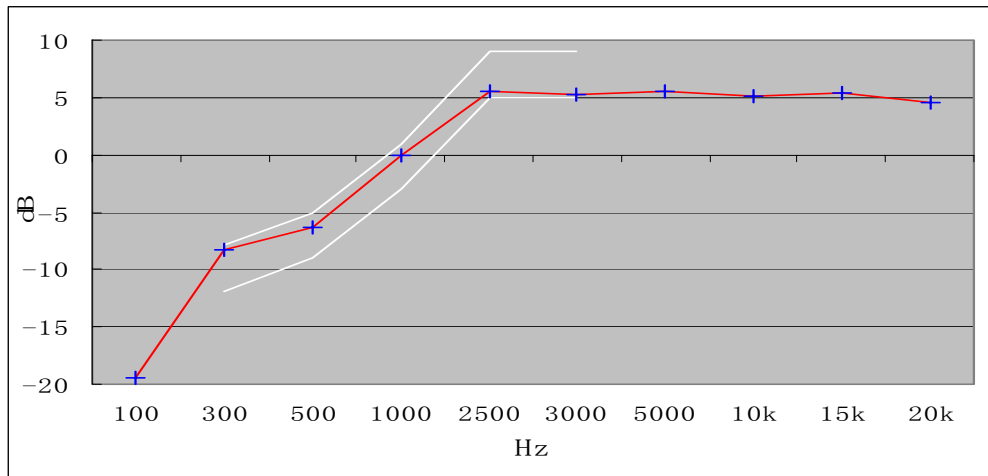

0dB=10mV at 1kHz (20% of the maximum rated system deviation).

### Modulation Limiting

- Adjust the transmitter per the manufacturer's procedure for full rated system deviation.
- Set the test receiver to measure peak positive deviation. Set the audio bandwidth for  $\leq 0.25$  Hz to  $\geq 15,000$  Hz. Turn the de-emphasis function off.
- Apply a **1000 Hz** modulating signal to the transmitter from the audio frequency generator, and adjust the level to obtain **60% of full rated system deviation**.
- Increase the level from the audio frequency generator by 20 dB in one step (rise time between the 10% and 90% points shall be 0.1 second maximum).
- Measure both the instantaneous and steady-state deviation at and after the time of increasing the audio input level.
- With the level from the audio frequency generator held constant at the level obtained in step e), slowly vary the audio frequency from 100 to 5000 Hz and observe the steady-state deviation. Record the maximum deviation.

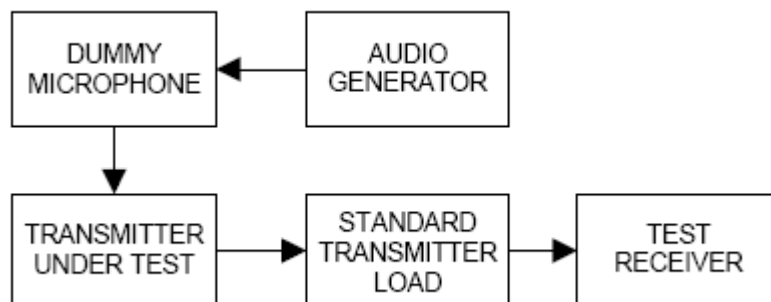

Test at five different modulating frequencies (100Hz ,300Hz, 500Hz, 1KHz, 2.5kHz, 5kHz), the output level of the audio generator was varied up to 1V and the FM deviation level was recorded.

Positive peak deviation

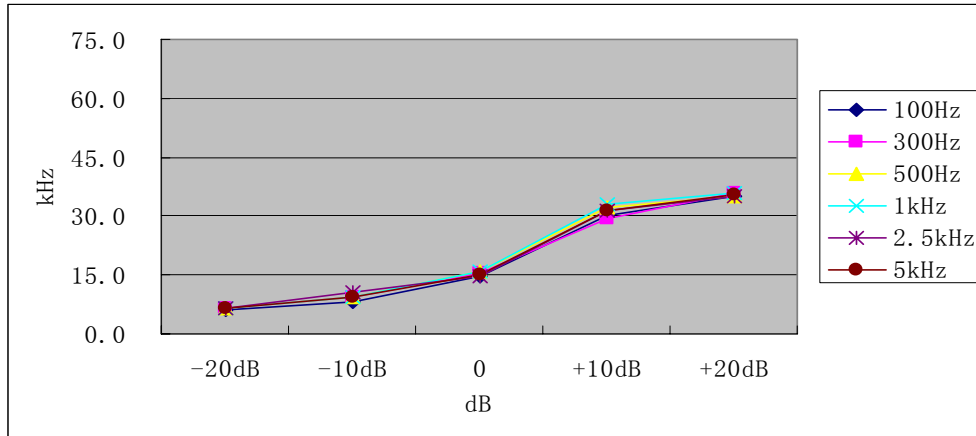

### 4.3 EUT Constructional Details

#### PT-400



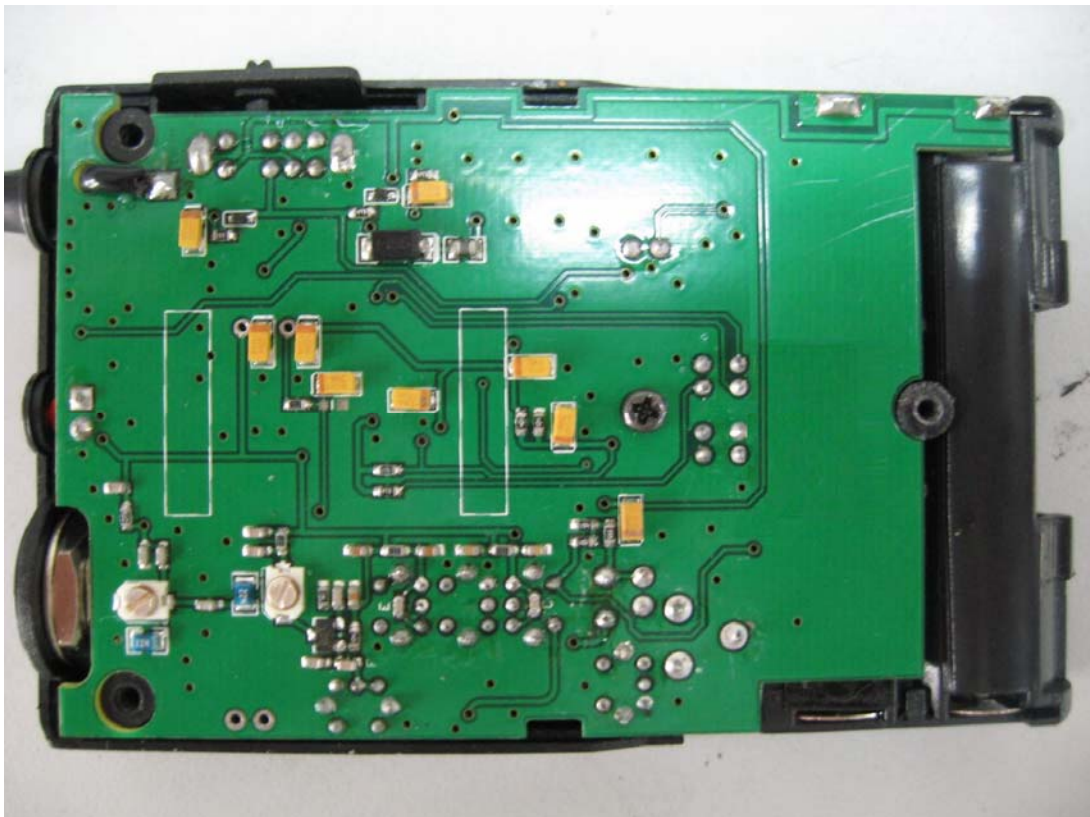



\*\*\*End of Report\*\*\*