



TEST REPORT

Report No. : HST201412-4424-FCC

Product description: Wireless Transmitter

Model/Type : PT-15

FCC ID QSRPT-15

Applicant's name: Enping Karsect Electronics Co.,
Ltd



TEST REPORT
FCC Part 74H: 2014
FCCID: QSRPT-15

Report Reference No.: HST201412-4424-FCC

Tested by (+ signature):  Yanbin Xing

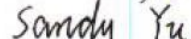
Review by (+ signature):  Sandy Yu

Approved by (+ signature).....:  Robin Peng

Date of issue: Jan. 10, 2015

Total number of pages: 27 Pages

Testing Laboratory.....: Guangdong Huesent Testing & Inspection Technology Co., Ltd.
(Accredited by CNAS, Accredited Number: L2885)

Address: No.91, Dongguan Zhuang Road, Guangzhou City, Guangdong Province,
China

Applicant's name: Enping Karsect Electronics Co., Ltd

Address: No. F45-1, District F, Foreign and Private Capital Industrial Zone, Enping,
Guangdong, China

Manufacturer's name: Enping Karsect Electronics Co., Ltd

Address: No. F45-1, District F, Foreign and Private Capital Industrial Zone, Enping,
Guangdong, China

Test specification.....: Entrusted testing

Standard.....: FCC Part 74H: 2014

Non-standard test method.....: N/A

Test Report Form No.: N/A

Test Report Form(s) Originator..: N/A

Test item description.....: Wireless Transmitter

Trade Mark: Karsect

Model/Type reference: PT-15

Ratings: 3.0Vdc 2*AA Batteries

TABLE OF CONTENT

	TEST REPORT	1
1	Test Summary	3
2	General Information.....	4
	2.1 Client Information	4
	2.2 General Description of E.U.T.	4
	2.3 Details of E.U.T.	4
	2.4 Description of Support Units.....	4
	2.5 Standards Applicable for Testing	4
	2.6 Test Location	5
	2.7 Deviation from Standards.....	5
	2.8 Abnormalities from Standard Conditions.....	5
3	Test Results	6
	3.1 E.U.T. Operation Condition	6
	3.2 Test Procedure & Measurement Data.....	7
	3.2.1 Carrier Radiated Power & Radiated Spurious Emissions.....	7
	3.2.2 Occupied Bandwidth	10
	3.2.3 Frequency Stability.....	13
	3.2.4 Modulation Characteristics.....	15
	3.2.5 Photographs	18
	3.2.6 EUT Constructional Details	20
	3.2.7 Antenna Photo	26
4	Equipments Used during Test.....	27

1 TEST SUMMARY

Test	Test Requirement	Standard Paragraph	Result
Carrier Radiated Power	FCC Part 2.1046	74.861 e) 1) 54–72, 76–88 & 174–216 MHz bands, 50 mW 470–608 and 614–806 MHz bands, 250 mW	PASS
Modulation Deviation	FCC Part 2.1047	74.861 e) 3) Within 75kHz	PASS
Frequency Stability	FCC Part 2.1055	74.861 e) 4) <0.005% 50 ppm	PASS
Operating Bandwidth	FCC Part 2.1049 c)	74.861 e) 5) Within 200kHz	PASS
Unwanted Radiation	FCC Part 2.1049 c)	74.861 e) 6) within the mask	PASS
Radiated Spurious Emission	FCC Part 2.1053	74.861 d) 3) < 43+10lgP(W) dB	PASS

Remark:

♣The EUT has one channel, which is located in the range 614.200 MHz to 697.800MHz.

Only test result of sample of in channels 614.200 MHz, 664.518 MHz and 697.800 MHz were recorded in this report.

2 GENERAL INFORMATION

2.1 Client Information

Applicant: Enping Karsect Electronics Co., Ltd
Address of Applicant: No. F45-1, District F, Foreign and Private Capital Industrial Zone,
Enping, Guangdong, China

2.2 General Description of E.U.T.

EUT Name: Wireless Transmitter
Item No.: Listed on the 3rd page
Serial No.: Not supplied by client

2.3 Details of E.U.T.

Power Supply: 3.0Vdc 2*AA Batteries
Main Function: Wireless microphone system with an associated receiver for
transmitting voice.

The final amplifier Collector Voltage and Collector Current are 0.29V & 3.5mA respectively.

Necessary Bandwidth: $2M+2DK= 2 \times 71 \text{ kHz} + 2 \times 20\text{kHz} \times 1.0 = 182 \text{ kHz}$

16 channels for each microphone; Modulation: F3E; Antenna Type: Fixed; Gained: 0 dBi

2.4 Description of Support Units

Connect the EUT to mains power, and then test the EUT with signal generator.

2.5 Standards Applicable for Testing

The standard used was FCC PART 74H, 2014

The EUT belongs to licensed low power auxiliary devices.

2.6 Test Location

GuangZhou Huesent Testing Service Co., Ltd.
No.91, Dongguanzhuang Road, Guangzhou, China.

Tel: 86-20-87221905, Fax: 86-20-87223892

CNAS- Accreditation No.: L2885.

CMA- Authorisation Certificate No.: 2008191614Z

ERP & Spurious Emission tests were subcontracted to the laboratory following-

CEPREI (headquarters) lab.

No.110, Dongguanzhuang Road, Tianhe District, Guangzhou city, Guangdong Province,
P.R. China

CNAS- Accreditation No.: L0462

Tel: 86-20-87237178 Fax: 86-20-87236171 Email: emc@ceprei.biz

FCC- Registration No: 258518 on Mar 25, 2008

2.7 Deviation from Standards

None.

2.8 Abnormalities from Standard Conditions

None.

3 TEST RESULTS

3.1 E.U.T. Operation Condition

Operating Environment:

Temperature: 20.0 °C~25 °C

Humidity: 50 ~70% RH

Atmospheric Pressure: 980~1012 mbar

EUT Operation: Test the EUT in transmitting mode.

Performed Carrier Radiated Power & Radiated Spurious Emissions testing in highest/ middle / lowest frequency spots within the range, and performed Occupied Bandwidth, Frequency Stability & Modulation Characteristics in middle frequency spot.

3.2 Test Procedure & Measurement Data

3.2.1 Carrier Radiated Power & Radiated Spurious Emissions

Test Requirement: FCC CFR 47 Part 74.861 e) 1) & d) 3)

Test Method: EIA/TIA 603-D:2010 section 2.2,
FCC CFR 47 Part 2.1047 & 1053

Test Date: Dec. 17, 2014

Measurement Distance: 3m (Semi-Anechoic Chamber)

Test Requirement:

(d) For low power auxiliary stations operating in the bands other than those allocated for TV broadcasting, the following technical requirements are imposed.

(3) The occupied bandwidth shall not be greater than that necessary for satisfactory transmission and, in any event, an emission appearing on any discrete frequency outside the authorized band shall be attenuated, at least, $43+10 \log^{10}$ (mean output power, in watts) dB below the mean output power of the transmitting unit.

(e) For low power auxiliary stations operating in the bands allocated for TV broadcasting, the following technical requirements apply:

(1) The power of the measured unmodulated carrier power at the output of the transmitter power amplifier (antenna input power) may not exceed the following:

(i) 54–72, 76–88, and 174–216 MHz bands—50 mW

(ii) 470–608 and 614–806 MHz bands—250 mW

Test Procedure:

The procedure used was EIA/TIA 603-D:2010. The receiver was scanned from the lowest radio frequency generated in the equipment to the tenth harmonic of the carrier. When an emission was found, the table was rotated to produce the maximum signal strength. An initial pre-scan was performed for in peak detection mode using the receiver. The EUT was measured for both the Horizontal and Vertical polarities and performed a pre-test three orthogonal planes.

The field strength is calculated by adding the Antenna Factor, Cable Factor & Preamplifier. The basic equation with a sample calculation is as follows:

Final Test Level = Receiver Reading + Antenna Factor + Cable Factor – Preamplifier Factor

An initial pre-scan was performed in the 3m chamber using the spectrum analyzer in peak detection mode. Quasi-peak measurements were conducted based on the peak sweep graph. The EUT was measured by Bilog antenna with 2 orthogonal polarities

Remove the EUT and replace it with substitution antenna. A signal generator was connected to the substitution antenna by a non-radiating cable. The absolute levels of the Carrier Radiated Power and spurious emissions were measured by the substitution.

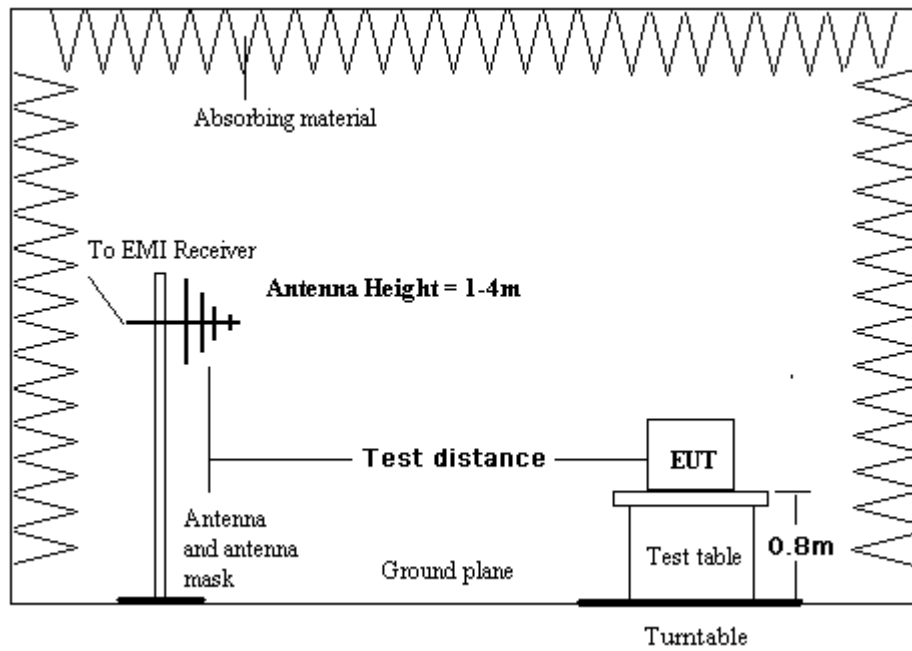

Test Result:

Carrier Frequency (MHz)	Factual Level dBm (mW)	conducted output power dBm (mW)	Limit in 74.861 e) 1)
614.200	2.8dBm(i.e.1.91 mW)	2.7dBm(i.e.1.86 mW)	24 dBm (i.e. 250 mW)
664.518	2.6dBm(i.e.1.82 mW)	2.5dBm(i.e.1.78 mW)	24 dBm (i.e. 250 mW)
697.800	2.6dBm(i.e 1.82 mW)	2.5dBm(i.e 1.78 mW)	24 dBm (i.e. 250 mW)

The Factual Level is ERP value.

Radiated spurious emissions:

614.200 MHz					
Spurious Emission Frequency (MHz)	Horizontal		Vertical		Limit (dBm)
	Factual Level (dBm)	Margin(dB)	Factual Level (dBm)	Margin(dB)	
307.100	<-43	NA	<-43	NA	-13
1228.400	-31.4	18.4	-29.1	16.1	-13
1842.600	-22.0	9.0	-16.7	3.7	-13
2456.800	<-43	NA	-40.1	27.1	-13
3071.000	<-43	NA	-40.1	27.1	-13
3685.200	<-43	NA	<-43	NA	-13
4299.400	<-43	NA	<-43	NA	-13
4913.600	<-43	NA	<-43	NA	-13
5527.800	<-43	NA	<-43	NA	-13
6142.000	<-43	NA	<-43	NA	-13
664.518 MHz					
332.259	<-43	NA	<-43	NA	-13
1329.036	-31.7	18.7	-29.6	16.6	-13
1993.554	-22.2	9.2	-16.2	3.2	-13
2658.072	<-43	NA	-40.3	27.3	-13
3322.590	<-43	NA	-42.1	29.1	-13
3987.108	<-43	NA	<-43	NA	-13
4651.626	<-43	NA	<-43	NA	-13
5316.144	<-43	NA	<-43	NA	-13
5980.662	<-43	NA	<-43	NA	-13
6645.180	<-43	NA	<-43	NA	-13
697.800 MHz					
303.900	<-43	NA	<-43	NA	-13
1215.600	-30.7	17.7	-29.5	16.5	-13
1823.400	-22.0	9.0	-16.1	3.1	-13
2431.200	<-43	NA	-40.7	27.7	-13
3039.000	<-43	NA	-41.1	28.1	-13
3646.800	<-43	NA	<-43	NA	-13
4254.600	<-43	NA	<-43	NA	-13
4862.400	<-43	NA	<-43	NA	-13
5470.200	<-43	NA	<-43	NA	-13
6078.000	<-43	NA	<-43	NA	-13

The Factual Level is ERP value.

The peak emission of other frequency in rang from 30MHz up to 10 times carrier were 25dB lower than the limit, hence no data was recorded in the report.

NA: Not applicable, since the level is over 30dB lower than the limit.

TEST RESULTS: The unit does meet the FCC requirements.

3.2.2 Occupied Bandwidth

Test Requirement: FCC CFR 47 Part 74.e) 5) & 6)

Test Method: FCC CFR 47 Part 2.1049 f) 2)

Test Date: Dec. 17, 2014

Requirements:

(e) For low power auxiliary stations operating in the bands allocated for TV broadcasting, the following technical requirements apply:

(5) The operating bandwidth shall not exceed 200 kHz.

(6) The mean power of emissions shall be attenuated below the mean output power of the transmitter in accordance with the following schedule:

(i) On any frequency removed from the operating frequency by more than 50 percent up to and including 100 percent of the authorized bandwidth: at least 25dB;

(ii) On any frequency removed from the operating frequency by more than 100 percent up to and including 250 percent of the authorized bandwidth: at least 35dB;

(iii) On any frequency removed from the operating frequency by more than 250 percent of the authorized bandwidth: at least $43+10\log_{10}$ (mean output power in watts) dB.

Test Procedure

Setup

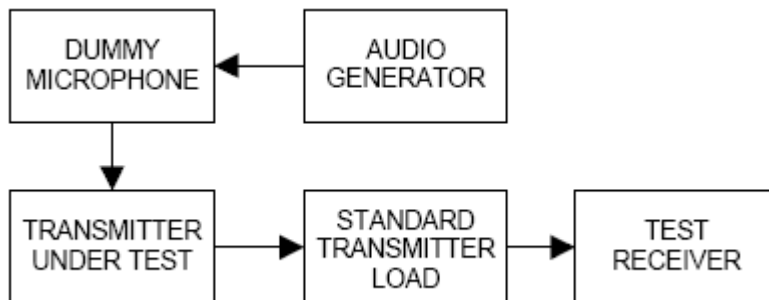

Input 2500Hz signal to the microphone, find the 50% rated deviation, add the level 16dB, test this status the 99% occupied bandwidth and record it.

Test Result: The graph as below, represents the emissions take for this device.

Occupied Bandwidth (99% of total power): 82.0 kHz.

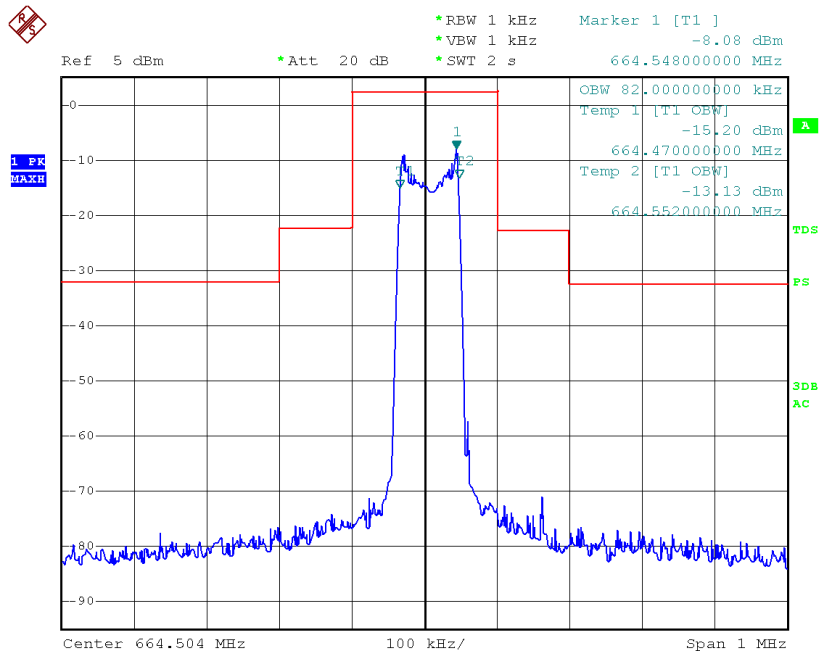

Date: 7.JAN.2015 09:13:18

Emission Mask: input with 10 kHz AF, 50% modulation + 16dB.

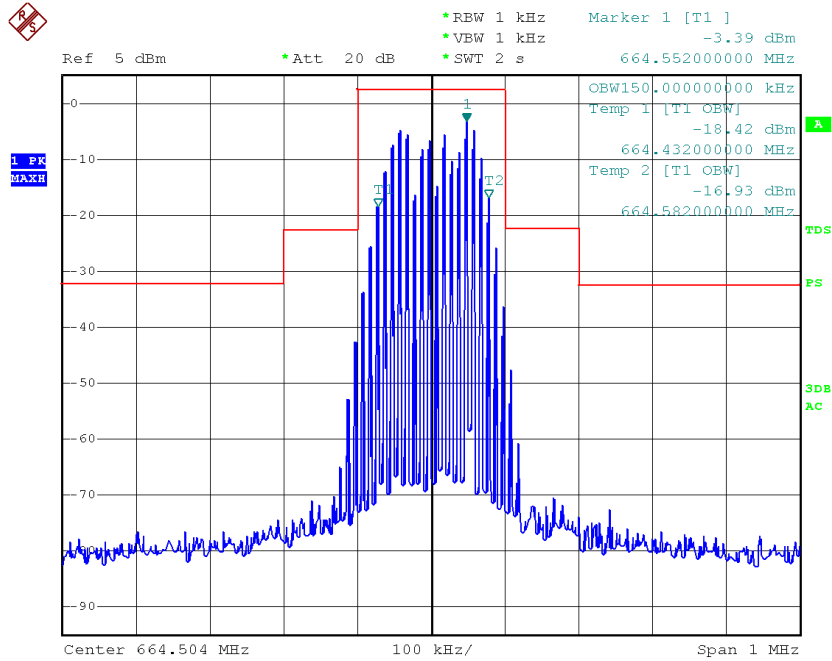

Date: 7.JAN.2015 09:12:19

Emission Mask: input with 15 kHz AF, 50% modulation + 16dB.

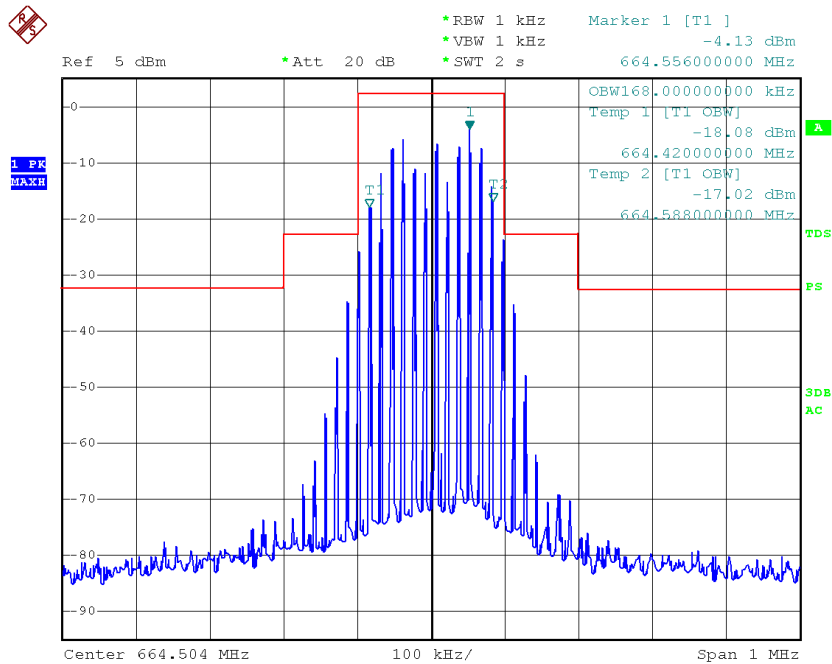

Date: 7.JAN.2015 09:11:27

Test results: The unit does meet the FCC requirements.

3.2.3 Frequency Stability

Test Requirement: FCC CFR 47 Part 74.e) 4)

Test Method: FCC CFR 47 Part 2.1055

Test Date: Dec. 17, 2014

Requirements: +/-50 ppm

(e) For low power auxiliary stations operating in the bands allocated for TV broadcasting, the following technical requirements apply:

(4) The frequency tolerance of the transmitter shall be 0.005 percent.

Test Procedure:

Frequency stability versus Environmental Temperature

The equipment under test was connected to an external DC power supply and the RF output was connected to a frequency counter via feed through attenuators. The EUT was placed inside the temperature chamber. After the temperature stabilized for approximately 20 minutes, the frequency of the output signal was recorded from the counter.

Frequency Stability versus Input Voltage

At room temperature ($25 \pm 5^\circ\text{C}$), an external variable DC power supply was connected to the EUT. The frequency of the transmitter was measured for 115%, 100% and 85% of the nominal operating input voltage. For hand carried, battery powered equipment, reduce primary supply voltage to the battery operating end point which shall be specified by the manufacturer.

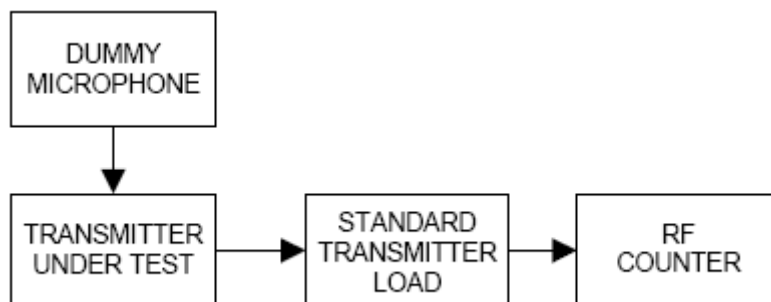

Test Result:

Assigned Frequency: 614.2MHz/ 664.518 MHz/ 697.800MHz				
Environment Temperature (°C)	Power Supplied (Vdc)	Frequency Measure with Time Elapsed Total emission within		
		+/-30.71kHz	+/-33.23kHz	+/-34.89kHz
50	3.0	-6.4	-7.2	-7.1
40	3.0	7.5	7.5	7.3
30	3.0	7.1	7.6	7.5
20	3.0	-6.3	-6.2	-7.2
10	3.0	-6.1	-5.8	-7.5
0	3.0	16.2	13.8	18.1
-10	3.0	-6.5	-6.4	-5.7
-20	3.0	-18.1	-16.0	-15.6
-30	3.0	-16.1	-17.7	-19.4
Environment Temperature (°C)	Power Supplied (Vdc)	Frequency Measure with Time Elapsed Total emission within		
		+/-30.71kHz	+/-33.23kHz	+/-34.89kHz
25	3.0	-4.2	-4.1	-3.6
25	2.8	1.5	1.1	0.5
25	2.6	1.2	1.5	1.2
25	2.4	-3.8	-4.2	-3.6

The EUT end point: 2.4Vdc

The results: The unit does meet the FCC requirements.

3.2.4 Modulation Characteristics

Test Requirement: FCC CFR 47 Part 74.e) 3)

Test Method: FCC CFR 47 Part 2.1047

Test Date: Dec. 17, 2014

Requirements:

(e) For low power auxiliary stations operating in the bands allocated for TV broadcasting, the following technical requirements apply:

(3) Any form of modulation may be used. A maximum deviation of ± 75 kHz is permitted when frequency modulation is employed.

Test Procedure:

Audio Frequency Response

The RF output of the transceiver was connected to the input of FSP 30 with FM deviation module through sufficient attenuation so as not to overload the meter or distort the reading. An audio signal generator was connected to the audio input of microphone.

The audio signal input level was adjusted to obtain **20% of the maximum rated system deviation at 1 kHz**, and recorded as DEV_{REF} . With the audio signal generator level unchanged, set the generator frequency between 100 to 5000 Hz. The transmitter deviations (DEV_{FREQ}) were measured and the audio frequency response was calculated as $20\log_{10} [DEV_{FREQ} / DEV_{REF}]$

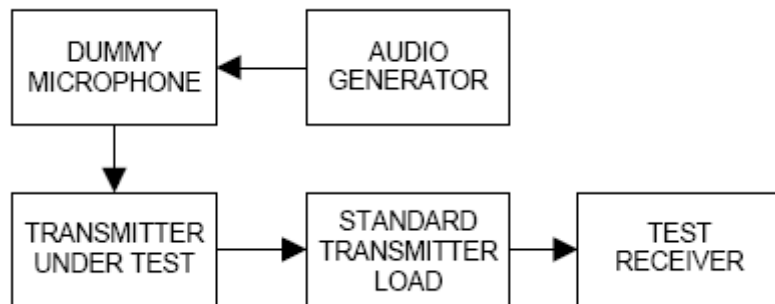

The plot(s) of Audio Frequency Response is presented hereinafter as reference.

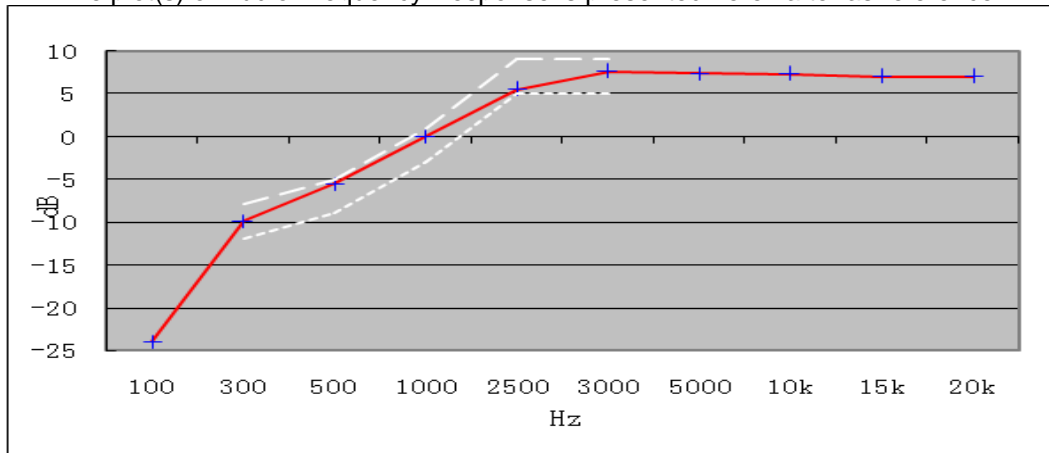

0dB=10mV at 1kHz (20% of the maximum rated system deviation).

Modulation Limiting

- Adjust the transmitter per the manufacturer's procedure for full rated system deviation.
- Set the test receiver to measure peak positive deviation. Set the audio bandwidth for ≤ 0.25 Hz to $\geq 15,000$ Hz. Turn the de-emphasis function off.
- Apply a **1000 Hz** modulating signal to the transmitter from the audio frequency generator, and adjust the level to obtain **60% of full rated system deviation**.
- Increase the level from the audio frequency generator by 20 dB in one step (rise time between the 10% and 90% points shall be 0.1 second maximum).
- Measure both the instantaneous and steady-state deviation at and after the time of increasing the audio input level.
- With the level from the audio frequency generator held constant at the level obtained in step e), slowly vary the audio frequency from 100 to 5000 Hz and observe the steady-state deviation. Record the maximum deviation.

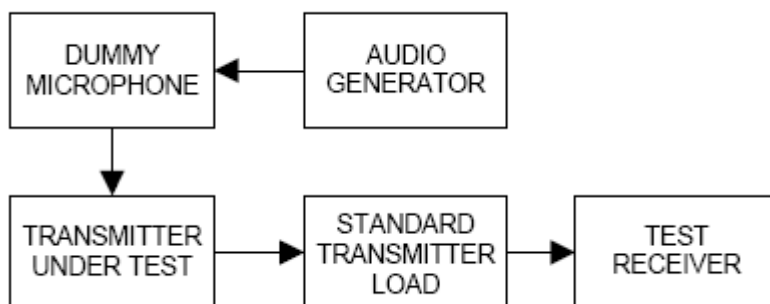

Test at five different modulating frequencies (100Hz ,300Hz, 500Hz, 1KHz, 2.5kHz, 5kHz), the output level of the audio generator was varied up to 1V and the FM deviation level was recorded.

Positive peak deviation

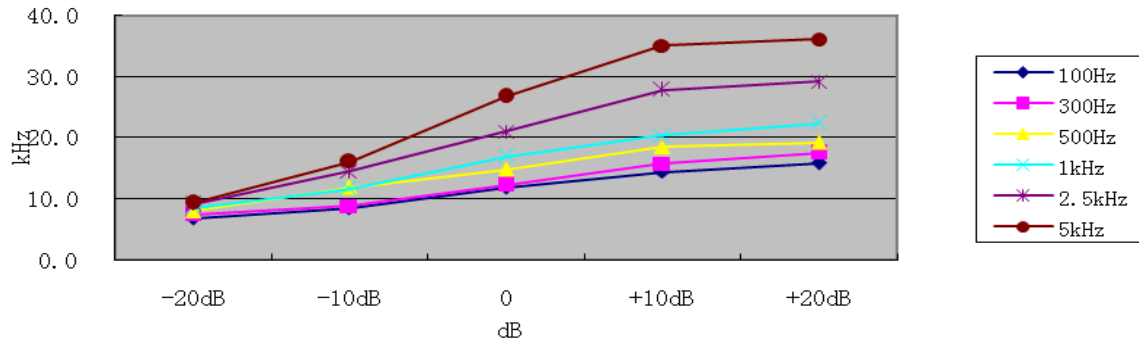

3.2.5 Photographs

Radiated Emission Test Setup

30MHz - 1GHz

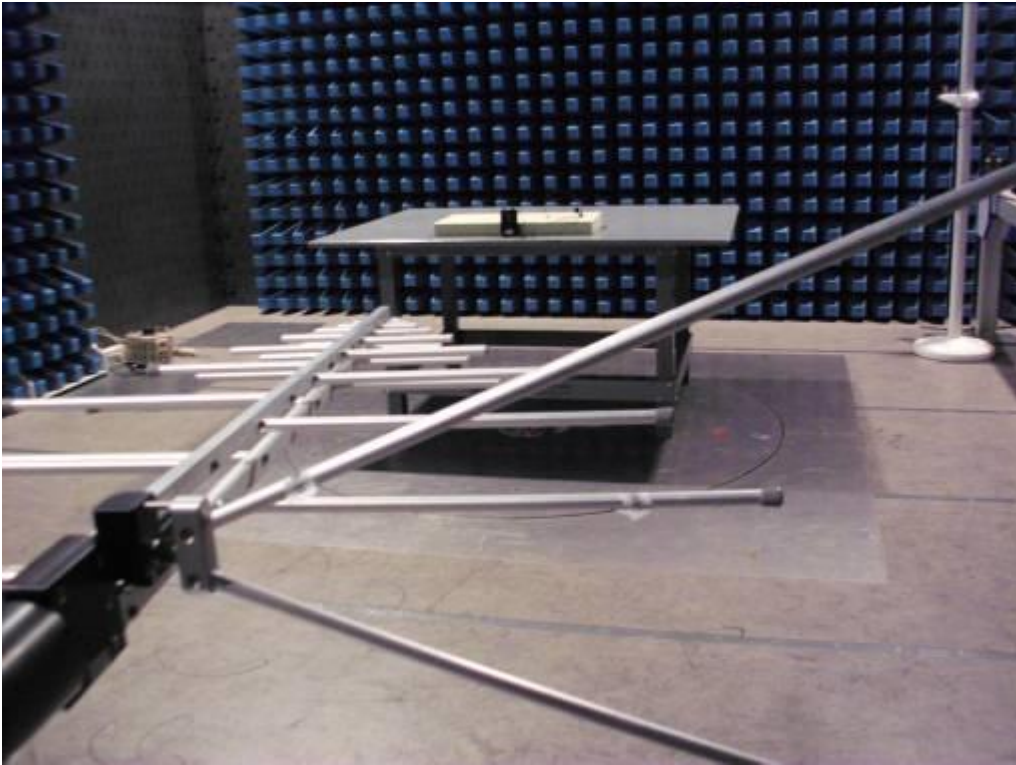

Above 1GHz



3.2.6 EUT Constructional Details

PT-15



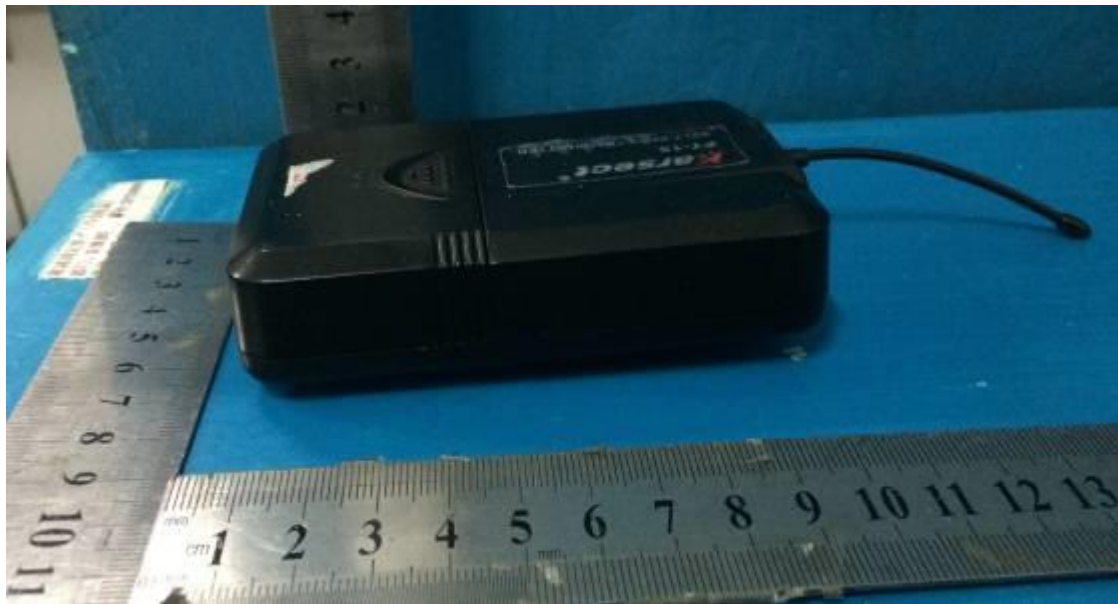
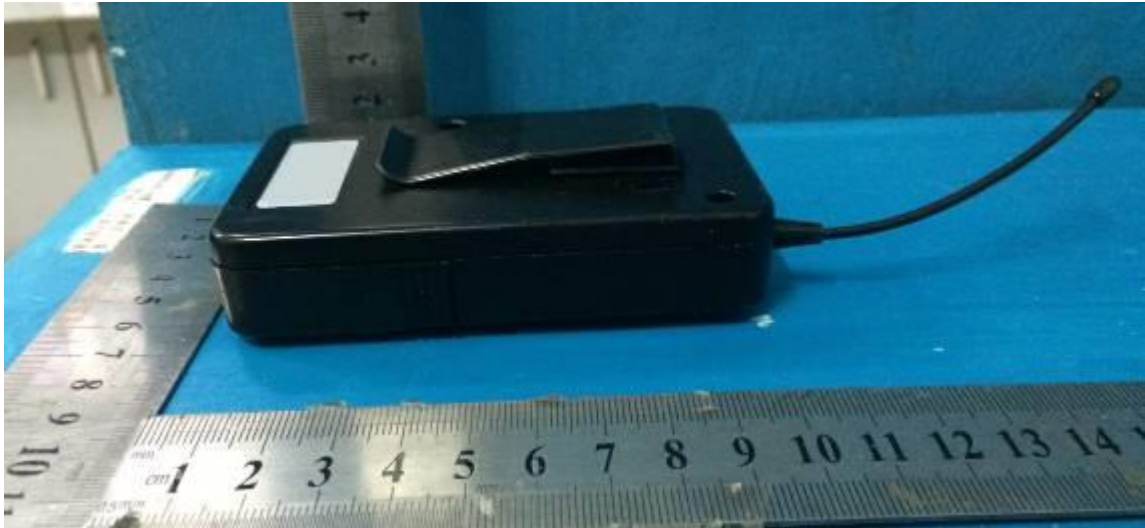





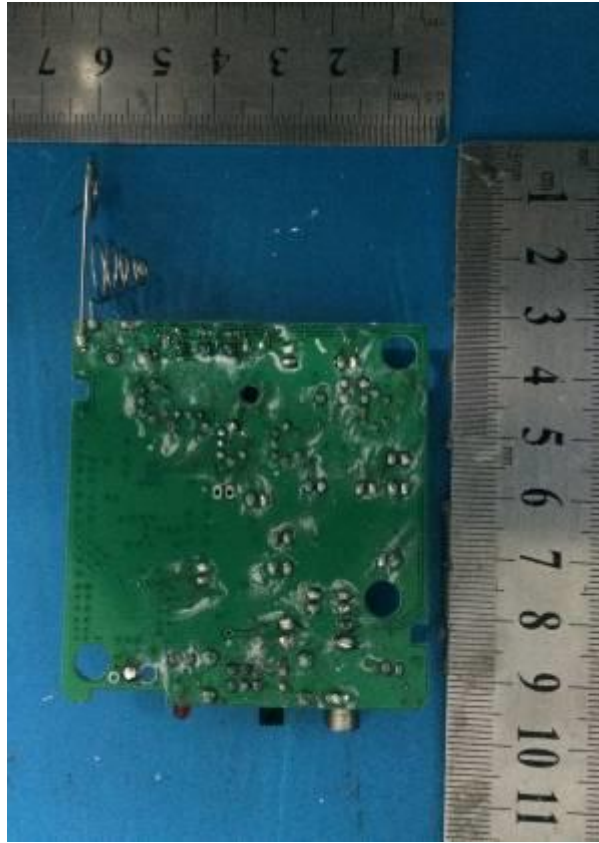



3.2.7 Antenna Photo

PT-15 with PCB Layout's Antenna



4 EQUIPMENTS USED DURING TEST

Item	Test Equipment	Manufacturer	Model No.	Inventory No.	Cal. Date	Cal. Due date
1	RF Generator	Rohde & Schwarz	SMT06	61-318	2014-6-8	2015-6-8
2	Spectrum Analyzer	R&S	CMU 200	/	2014-6-8	2015-6-8
3	EMI Test Receiver	Rohde & Schwarz	ESU	/	2014-6-8	2015-6-8
4	Power Meter	Rohde & Schwarz	URV35	EMC1506	2014-6-8	2015-6-8
5	Audio Analyzer	Rohde & Schwarz	UPL	EMC1508	2014-6-8	2015-6-8
6	Antenna Positioner	ETS-LINDGREN	/	/	2014-6-8	2015-6-8
7	Turn table	ETS-LINDGREN	/	/	2014-6-8	2015-6-8
8	Multi-Device Controller	ETS-LINDGREN	/	/	2014-6-8	2015-6-8
9	EMI Test Software	Ceprei	/	/	2014-6-8	2015-6-8
10	Coaxial cable	Ceprei	/	/	2014-6-8	2015-6-8
11	Coaxial cable	Ceprei	/	/	2014-6-8	2015-6-8
12	Power Sensor	Rohde & Schwarz	URV5-Z7	EMC1507	2014-6-8	2015-6-8
13	Temperature Chamber	Gongwen	GDS-250	1150	2014-6-8	2015-6-8
14	D.C. Power Supply	WELLSTAR	PS-205A	SEL0045	2014-6-8	2015-6-8
15	Humidity/ Temperature Meter	Shanghai	ZJ1-2B	SEL0101 to SEL0103	2014-6-8	2015-6-8
16	Barometer	ChangChun	DYM3	SEL0088	2014-6-8	2015-6-8
17	Multimeter	Victor	VC9805A+	3000125	2014-6-8	2015-6-8
18	DC Power Supply	DG HuaYang	PS-3030	9862036	2014-6-8	2015-6-8
19	Low loss coaxial cable	HST	2 m	EMC1008	2014-6-8	2015-6-8
20	Monopole Antenna	HST	N/A	N/A	2014-6-8	2015-6-8
21	Noise Generator	Ningbo Zhongce	DF1681	EMC0009	2014-6-8	2015-6-8
22	Antenna	R & S	HF906	/	2014-5-10	2016-5-10
23	3m Semi-anechoic Chamber	ABLATROSS	SAC-3	/	2014-5-10	2016-5-10
24	EMI Receiver	R & S	ESCI-3	/	2014-5-10	2015-5-10
25	Spectrum Analyzer	R & S	FSP30	/	2014-5-10	2015-5-10
26	BiConiLog Antenna	SCHWARZBECK	SWB-VULB 9163	/	2014-5-10	2015-5-10
27	Pre-amplifier	B & Z TECHNOLOGIES	SCA-SCU18	/	2014-5-10	2015-5-10

End of report