

K S S E R I E S

UHF

PLL

LCD

WIRELESS SYSTEM

THE GUITARIST UHF

THE PRESENTER UHF

THE VOCAL ARTIST UHF

THE HEADSET UHF

agent:

CATALOG

1、 FOREWORD	2
2、 INTRODUCTION	2
3、 SYSTEM FEATURES	2
4、 SYSTEM COMPONENTS	2
5、 RECEIVER FUNCTIONS/FEATURES	3
6、 TRANSMITTER FUNCTIONS/FEATURES	4
7、 TRANSMITTER FUNCTIONS/FEATURES	5
8、 SYSTEM CONNECTIONS	6
9、 TRANSMITTER CONNECTIONS	7
10、 RECEIVER OPERATION INSTRUCTION	8
11、 OPERATION INSTRUCTION	9
12、 OPERATION INSTRUCTION	10
13、 ADJUSTING CODE INSTALLATION	11
14、 CHECK THE TRANSMITTER BATTERY POWER	12
15、 RACK MOUNTING DUAL RECEIVERS	13
16、 SPECIFICATIONS	14

SYSTEM COMPOSITION

1.Receiver	X1
2.Wireless microphone or body-pack transmitter	X1
3.Audio cable	X1
4.AC power adapter of special receiver	X1
5.19-inch Audio equipment installing rack	X2
6.Battery 1.5V	X2
7.User guide	X1

FOREWORD

Thanks for purchasing this product, please read this instruction carefully so that can understand how to operate the product of the style you bought correctly. Please store this instruction in a safe place after reading as a reference in the future.

This professional series wireless microphone system used an efficient American, low consumption discharging technique with a super sensitive UHF high broadband frequency receiver and controlled with 10ppm crystal, matched with an independent developed mobile frequency compression, expander circuit, image frequency limiting circuit, a multiple checked silent and nosy circuit, diversity receiving circuit, switch impact noise defeat circuit, resist reverberation circuit and changed output controlled slowly system and finished on its item named pattern line. Every system is available to an excellent electric function by Q.C. strictly.

INTRODUCTION

Your new wireless Series system is designed to give you the best of both sound reinforcement worlds: the freedom of a wireless system, and the excellent quality. This manual covers each of the Series system: The Vocal Artist-UHF, The Presenter-UHF, The Headset-UHF and The Guitarist-UHF.

SYSTEM FEATURES

1. 1000 Selectable UHF channels. (470.00MHz-690.00MHz, 690.00MHz-865.00MHz)
2. Adopt the PLL-Synthesized control technic.
3. True Diversity Operation.
4. Advanced Digital Tone Lock Squelch.
5. Soft-touch Controls for Set-up and Operation.
6. LCD Information Display
7. Transmitter Battery-life Fuel Gauge on Receiver
8. Balanced XLR and Unbalanced 1/4" Outputs

SYSTEM COMPONENTS (FIGURE 1)

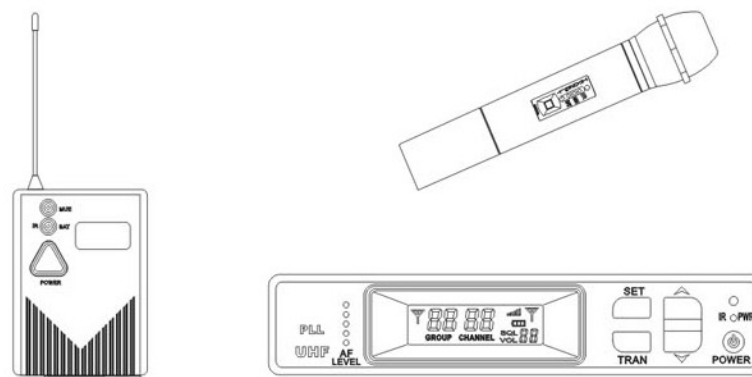

FIGURE 1

Body -Pack Transmitter (Compose lavalier microphone systems. Headset microphone systems and Guitar Microphone systems.)

Hand-Held Microphone Transmitter (Compose handheld microphone systems.)

Standard Diversity Receiver

RECEIVER FUNCTIONS/FEATURES(FIGURE 2)

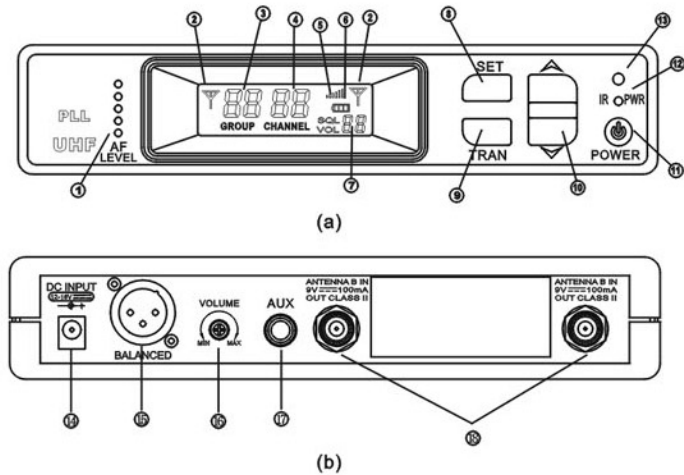

FIGURE 2

a. Front Panel

1. **AF LEVEL Indicators:** Indicate audio signal strength. Green light indicate normal operation. Red light indicate approaching overload condition or excessive audio levels.
2. **Receiving Antennal Indicator:** Appears on the both side left and right of the display, depending on which antenna is receiving the strongest RF signal.
3. **CHANNEL GROUP Display:** Indicates the pre-selected compatible Frequency Group number in which the system is operating. (1-25 group, frequency band width is 25MHz/group)
4. **CHANNEL Display:** Indicates the Frequency data of the inside channel group (1-40 Channels, the channel's interval is 25KHz).
5. **RF display:** Indicate the RF strength and weakness.
6. **Transmitter battery display:** Display flash, indicate the transmitter's battery power lack.
7. **SQL Display:** Indicates current SQL data -95dBm to -50dBm (1-50).
8. **SET Button:** Choose Group/Channel/SQL; Enter setting or exit adjusting.
9. **TRAN Button:** Transfer the channel's information to transmitter by infrared. Make Channel's information same as the receiver; IR light flash when transferring information.
10. **^/∨ Button:** Set Group/Chanel/SQL data .
11. **POWER Button:** Turns ON/OFF the receiver.
12. **IR/PWR indicator:** Indicate the IR/POWER.
13. **IR Transferring Window:** Transfer the data of receiver to transmitter.

b. Back Panel Receiver

14. **Power connector:** Accepts power DC (12V-18V) from the supplied AC adapter.
15. **XLR Output connector:** Balance XLR output connector.
16. **VOLUME:** Adjust audio output level of receiver.
17. **1/4" Output connector:** unbalance 1/4" output connector.
18. **Antenna Input Connectors:** Supply the RF for receiver by TNC antenna. They also provide 9V DC output power for use with the remotely located antennas amplifier.

HANDHELD TRANSMITTER FUNCTION/FEATURES(FIGURE 3)

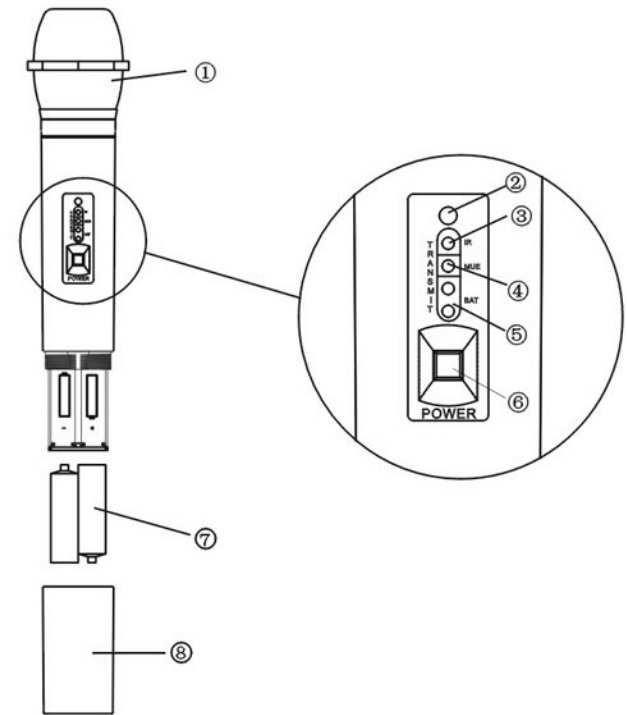

FIGURE 3

1. **Grille:** Protects the microphone cartridge and helps reduce breath sounds and wind noise.
2. **IR receiving window:** Receive the data of receiver.
3. **IR indicator:** Light indicate waiting for adjusting.
4. **MUTE indicator:** Light indicate the mute.
5. **BATTERY Indicator:** Green light indicate the battery normal. Red light indicate the battery lack and should be renewed.
6. **POWER button:** Turn ON/OFF transmitter and control mute.
7. **Battery:** Suggest using 2XAA(1.5V) alkali battery.
8. **Battery Cover:** Rotate clockwise to close tightly. rotate lounterclockwise to open.

BODY-PACK TRANSMITTER FUNCTION/FEATURES(Figure 4)

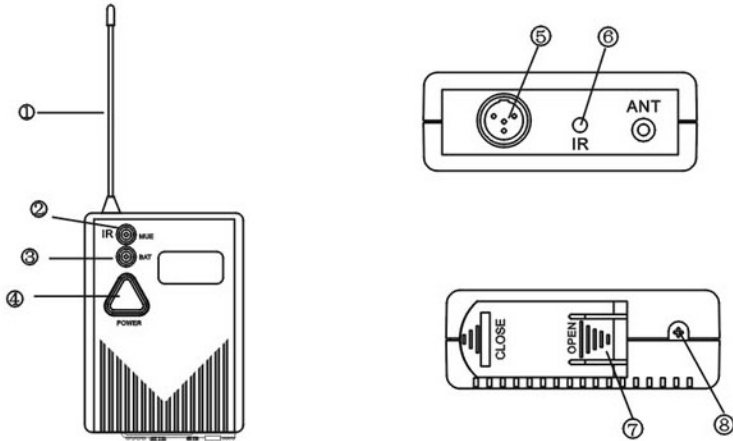

FIGURE 4

1. **ANTENNA:** Set the variable 1/4 wavelength antenna in the transmitter.
2. **IR/MUTE Indicator:** Green light indicate waiting for adjusting code. Red light indicate entering mute. Light go out indicate the system is normal condition.
3. **POWER Indicator:** Green light indicate power normal. Red light indicate power lack and should be renewed.
4. **POWER Switch:** Turn ON/OFF transmitter and control mute.
5. **Input Connector:** It is TA4F 4 PINS connector; It is suitable for the lavalier microphones system / Headset microphone systems /Guitar Microphone systems.
6. **IR Receiving Windows:** Accept the data from receiver.
7. **Battery Cover:** Open the cover and set 2XAA(1.5V) Alkali battery.
8. **Audio gain:** Adjusting it can change the audio sensitivity.

SYSTEM CONNECTIONS:

1.RECEIVER POWER CONNECTION

Plug the DC power supply into the power connector on the back of the receiver, Connect the other end of the power supply into an electrical outlet AC 120V/220V/50Hz ,as shown in Figure 5.

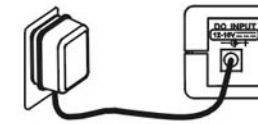

FIGURE 5

2. ATENNA CONNECTION

Attach the two antennas to the ANTENA connectors, as shown in Figure 6.

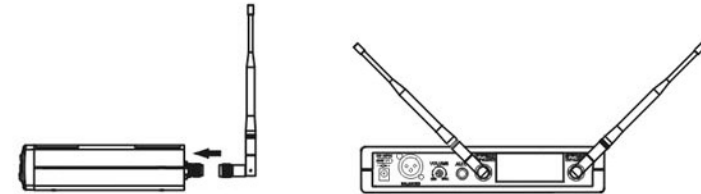

FIGURE 6

3.AUDIO CONNECTION

Connect audio cable from the audio output to the audio input of the Amplifier and Mixer audio equipments , as shown in Figure 7.

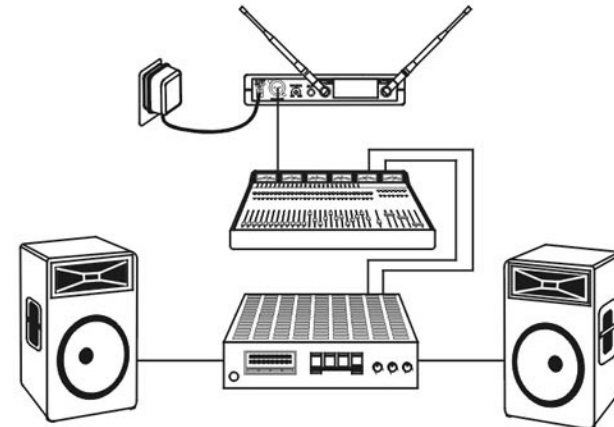

FIGURE 7

TRANSMITTER CONNECTIONS

1. Lavalier Microphone connection.(Figure 8)



FIGURE 8

2. Headset Microphone connection(Figure 9).

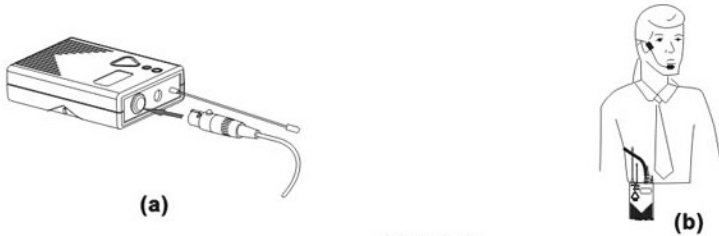

FIGURE 9

3. Guitar Microphone connection(Figure 10).

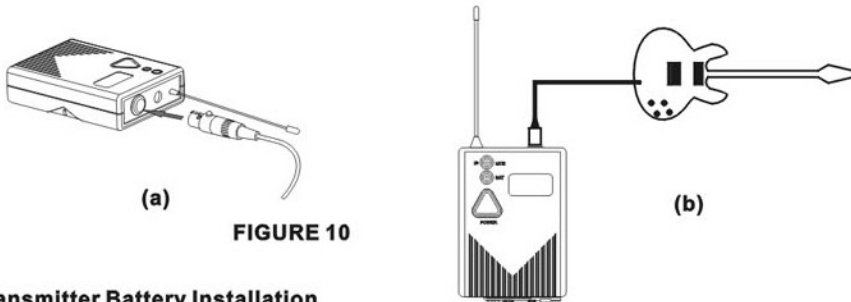

FIGURE 10

4. Transmitter Battery Installation

Open the battery cover and insert the two AA(1.5V) Alkali battery(Figure 11)

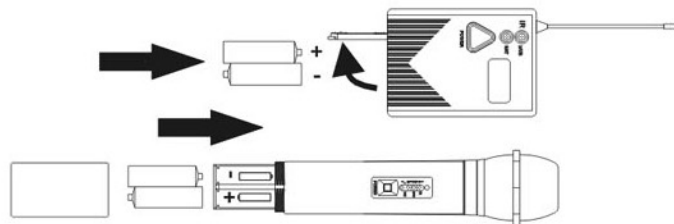

FIGURE 11

Receiver operation Instruction(Set system's channel's information).

CAUTION: Don't turn on the transmitter before turn on the receiver.

1. Open the receiver (Figure 12).



FIGURE 12

2. CHANNEL INSTALLATION:

a. Press SET button, the CHANNEL display will flash (Figure 13)

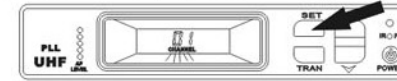

FIGURE 13

b. Press the ▲ or ▼ button. choose the channel's data which you need(Figure 14)

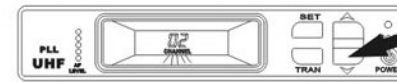

FIGURE 14

3. GROUP INSTALLATION:

a. Press the SET button . the GROUP display will flash (Figure 15).



FIGURE 15

b. Press the ▲ or ▼ buttons. Choose the group's data which you need(Figure 16).

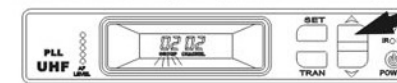

FIGURE 16

4. SQL INSTALLATION:

a. Press the SET button. the SQL display will flash(Figure 17).

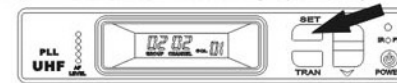

FIGURE 17

b. Press the ▲ or ▼ button, Choose the SQL'S data which you will need(Figure 18).

Note: Suggest choosing the SQL data from 15 to 20. If you choose the SQL data too low, the system's resisting interference function lower. If you choose the SQL data too high, the system's operating range will be contracted.



FIGURE 18

NOTE: All above GROUP/CHANNEL /SQL installations, the receiver finish the data installations and wait for transferring the data to transmitter adjusting by IR. Under the receiver will not be re-set, the data will be kept forever.

Operation instruction:

Turn on transmitter

Note: don't turn on the transmitter when the receiver off. You can turn on the transmitter after the receiver on and the channel have been set well.

1. Length press (2-3 seconds) the POWER button of the transmitter IR MUE BAT green light, the transmitter enter adjusting code and waiting for transferring the RF signal(Figure 22).

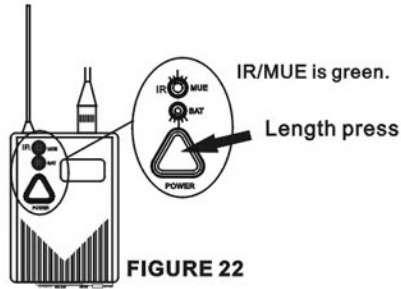

- 2.If it need to adjust code(adjust channel), enter the adjusting code mood. After 20 seconds approximately, the IR green light black out, exit the adjusting code . The MUE BAT light, indicate entering mute. If needn't adjusting code, short press(1 second) POWER button, BAT light only; enter normal operation(Figure 23).

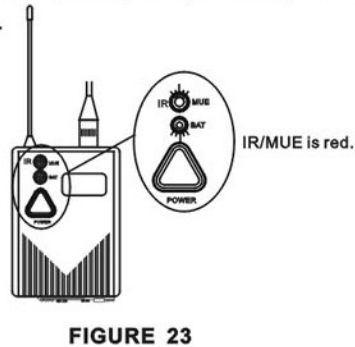

- 3.Short press(1 second) POWER button, BAT light only; enter normal operation(Figure 24).

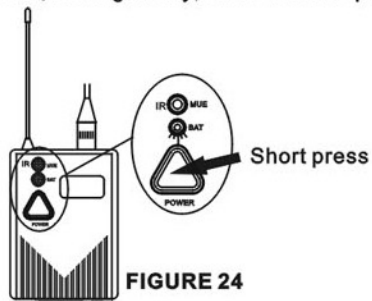

Operation instruction.

Turn On the transmitter .

Note: Don't turn on the transmitter when the receiver off. You can turn on the transmitter after the receiver on and the channel have been set well.

1. Length press(2-3 seconds) the POWER button of the transmitter. the IR MUE BAT light, the transmitter enter adjusting code and transport the RF signal(Figure 19).

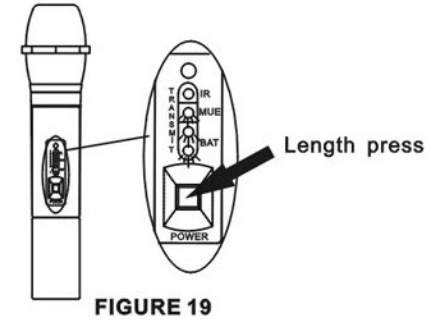

2. If it need to adjust code(adjust channel), enter the adjusting code mood. After 20 seconds approximately, the IR green light black out, exit the adjusting code. The MUE BAT light , indicate entering mute. If needn't adjusting code, short press(1 second) POWER button enter normal operation (Figure 20).

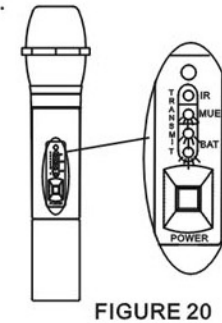

- 3.Short press(1 second) POWER button, BAT light only; enter normal operation (Figure 21).

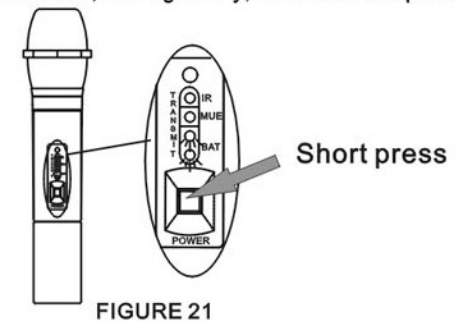

ADJUSTING CODE INSTALLATION:

Note: a. The system finish adjusting code one time, the channel's data will be kept forever; re-operation many times without re-adjusting code.

b. Adjusting code(Adjust channel) one time, whatever, the transmitter will re-return on again.

c. The adjusting code need to be finished after turned on the transmitter 20 seconds; othernise the IR green light will back out auto matically and enter the mute. The trans-mitter only transfer the channel's data of RF last time.

1. First, length press(2-3 second) the POWER button of receiver, get through the power of receiver; and then press the POWER button of transmitter, get through the power of transmitter (Figure 25).

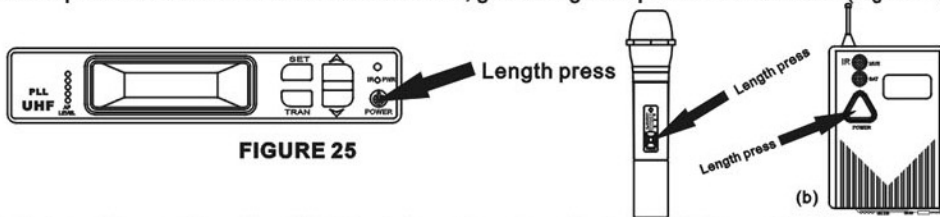

FIGURE 25

2. IR window of transmitter aim at the IR window of receiver; the both of distance is not more 50cm(Figure 26)

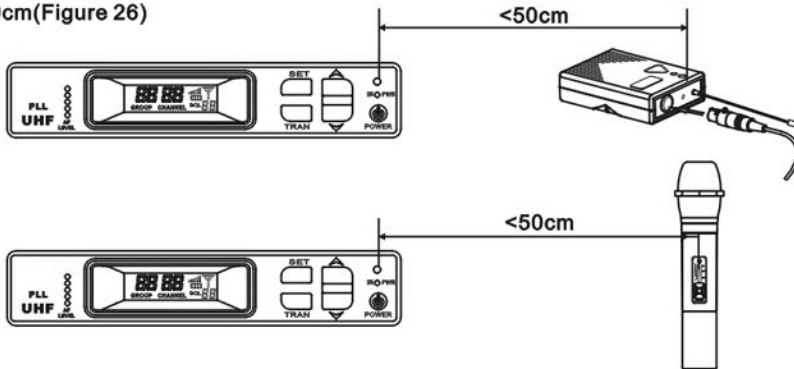

FIGURE 26

3. Press the TRAN button of receiver, the IR/PWR light flash, indicate the transmitter and receiver enter adjusting code.(Figure 27).



FIGURE 27

4. When the transmitter accept the adjusting code data of receiver, the system will appear bellow:

a. The IR of transmitter will black out, indicate finishing adjusting code and enter MUTE (MUE BAT light). At the time, please short-press the POWER button and enter the normal operation; on the contrary, the system don't finish adjusting code and need re-adjust code.(Figure 28)



FIGURE 28

b. When the green IR light of change to red MUR light, indicate the system finishing adjusting code and enter MUE(MUE BAT light), at the time, please short-press POWER and enter normal operation; on the contrary, the system don't finish adjusting code and need re-adjust code.(Figure 29)

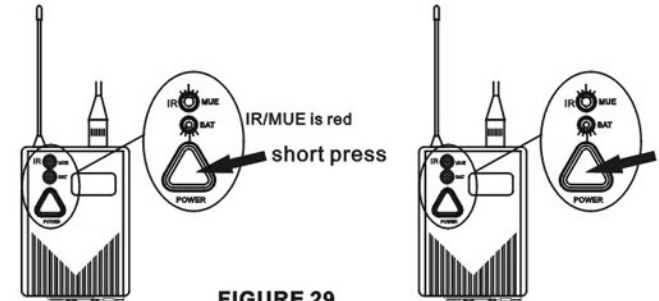

FIGURE 29

5. Get through all above operation and adjusting code well, the system may be operated normally.

Note: When the transmitter and receiver are adjusting code(IR/PWR flash), it don't infect normal operation. After 10 seconds approximately, the IR/PWR light flash will stop automatically. Also, touch the POWER OF transmitter lightly, the IR/PWR light flash will stop and don't infect the installation data of systems.

CHECK THE TRANSMITTER BATTERY POWER:

With the receiver and transmitter turned on, after adjust code correctly, short-press the POWER button of transmitter and enter the normal normal transmitting sound (th BAT light only). Observe the battery display icon on the LCD display. The number of bars is on the icon. The 3pcs bars indicate the battery enough. the 2pcs bars indicate the battery moderately. The 1pc bar indicate the battery lower. The battery display flash, indicate the battery power lack and need to renew new battery (Figure 30)



FIGURE 30

Rack Mounting Dual Receivers

1. Align the receivers side by side so that the front panels both face the same direction.
2. Place the supplied straddle bars in the recesses on the top and bottom of the receivers, so that bars overlap both receivers. Refer to Figure 31.

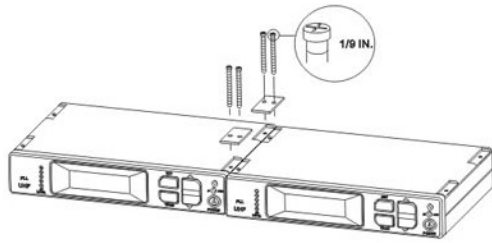

FIGURE 31

3. Secure the straddle bars to the receivers using the supplied screws.
 - CAUTION:** Do not overtighten the screws. Doing so may damage the printed circuit boards.
4. Position the rack-mount brackets over the holes in the sides of each receiver, as shown in Figure 32.
5. Secure the brackets to the receivers with the supplied screws.

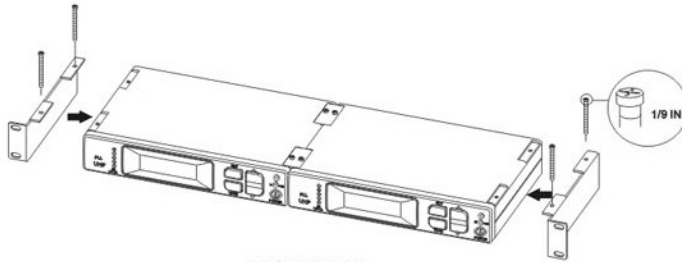

FIGURE 32

6. Slide the linked receivers into a 19-inch audio equipment rack, as shown in Figure 33.
7. Secure the brackets to the rack using all four of the supplied screws.

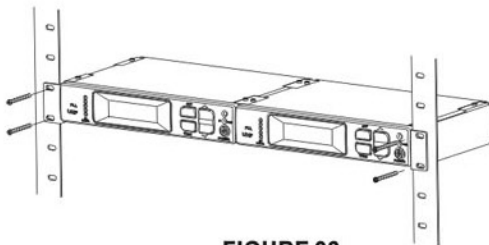

FIGURE 33

SPECIFICATIONS

NOTE: For a list of compatible frequencies that are usable in your area, refer to the supplied frequency supplement.

RF Carrier Frequency Range

470.00MHz to 865.00 Mhz (Available frequencies depend on the applicable regulations in the country where the system is used).

Refer to the frequency supplement supplied with the system.

Effective Range

100m(300 ft.) Under optimal conditions

NOTE: Actual working range depends on RF signal absorption, reflection, and interference

Audio Frequency Response

25 to 15,000 Hz, ± 2 dB

NOTE: Overall system frequency response depends on the microphone element.

Transmitter Input (Figure 34)

Connector:	TA4F
Input Configuration:	Unbalanced, active
Actual Impedance:	18k Ω with lavalier microphone 1M Ω with instrument cable
Maximum Input Level:	10 Vp-p (12dBV) for 1% THD at minimum gain setting using 1 kHz signal.
TA4F Connector Pin Assignments:	Pin 1: tied to Ground Pin 2: Tied to +5V Pin 3: Tied to Audio Pin 4: Tied thru 20k Resistor to Ground. (On instrument adapter cable, Pin 4 floats)
Voltage for Remote Power:	+5V supplied to microphone cartridge

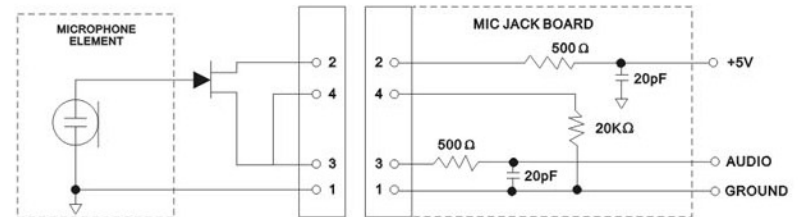

NOTE: LAVALIER MIC TIES PINS 3 AND 4 TOGETHER; THE GUITAR CABLE DOES NOT.

FIGURE 34

Transmitter Output

Actual Impedance:	50 Ω
Nominal Output Level:	20 mW
Maximum Output Level:	30 mW

Transmitter Input

Input Configuration:	Unbalanced, active
Actual Impedance:	20kΩ
Maximum Input Level:	10 Vp-p (12 dBV) for 1% THD at minimum gain setting using 1 kHz signal.

Transmitter Output

Actual Impedance:	50 Ω
Nominal Output Level:	20 mW
Maximum Output Level:	30 mW

Receiver Input

Connector:	Antenna	Power Input
Connector Type:	TNC	
Actual Impedance:	50 Ω	
Nominal Input Level:	-95 to -30 dBm	15 VDC
Maximum Input Level:	+6 dBm (-20 dBm recommended)	18 VDC
Voltage for Remote Power:	9 V DC, 100 mA maximum	

Receiver Output

Connector:	High Z Audio	Low Z Audio*
Output Configuration:	Unbalanced(1/4 in.)	Balanced(XLR)
Actual Impedance:	3kΩ	22 Ω
Nominal Input Level:		
Voltage/Current/Phantom Power Protection?	Yes	Yes

*Output Level: Microphone Level = Line level - 20 dB

Transmitter Audio Polarity

Positive pressure on microphone diaphragm produces positive voltage on pin2 (with respect to pin 3 of low impedance output) and the tip of the high impedance 1/4-inch output.

Transmitter Gain Adjustment Range

Handheld Transmitter:25dB
Lapel Transmitter:25dB

Receiver Audio Output Level (38 kHz deviation, 1 kHz tone)

XLR connector (into 600 ohm load): +3.9 dBV(line),-17 dBV (mic)

1/4 inch connector (into 3000 ohm load): -2 dBV

Impedance

Lapel Transmitter (input): 1 Megohm

Receiver : 50 ohms at line level; 2000ohms at mic level

Modulation

±38 KHz deviation compressor-expander system with pre-and de-emphasis.

RF Power Output

Lapel Transmitter, Handheld Transmitter : 30 mW maximum

Dynamic Range

>100 dB, A-weighted

RF Sensitivity

1.26 V for 12 dB SINAD (typical)

Image Rejection

80 dB typical

Spurious Rejection

75 dB typical

Ultimate Quieting (reference ± 38 kHz deviation)

>105 dB, A-weighted

System Distortion (reference ± 38 kHz deviation, 1 kHz modulation)

0.3% total harmonic distortion, typical

Power Requirements

Lapel Transmitter, Handheld Transmitter : 3V alkaline battery ;

Receiver : 12 - 18 V DC (negative ground), 550 mA

Battery Life

8 to 9 hours

Operating Temperature Range

-20° to 49° C (-4° to 120° F)

NOTE: Battery characteristics may limit this range.

Overall Dimensions

Lapel Transmitter: 83.4 mm L x 60.9 mm W x 22.3 mm H (3.28 x 2.40 x 0.90 in.)

Handheld Transmitter: 239 mm L x 51 mm Dia (9.41 x 2 in.)

Receiver: 43 mm H x 218 mm L x 149 mm W (1.69 x 8.58 x 5.90 in.)