



Copyright 2008, Karsect Incorporated  
[www.karsect.com](http://www.karsect.com).

# UHF

## PROFESSIONAL WIRELESS MICROPHONE OPERATING INSTRUCTIONS

The vocal artis \_\_\_\_\_ UHF  
The presenter \_\_\_\_\_ UHF  
The headset \_\_\_\_\_ UHF  
The guitarist \_\_\_\_\_ UHF

## Contents

1. Contents / Attentions.....	1
2. Foreword / System Introduction / System Feature/ System Type.....	2
3. WR400&4Front and rear panel function instruction.....	3
4. HT400 / PT400 Transmitter function instruction.....	4
5. HT400 / PT400 Transmitter battery installation.....	5
6. Three type of PT400 Transmitter connection .....	6
7. System Connection.....	7
8. Receiver installation in 19 inch equipment rack.....	8
9. Specification.....	9

## Attentions

1. The minimum space around equipment should be more than 30cm to keep enough ventilation.
2. Please don't cover the vent hole of equipment to block the ventilation by news paper, table cloth and window curtain....
3. Please don't put any fire on the equipment, such as burning candle.
4. Please don't clear the equipment by water and wet cloth to avoid the damage.
5. Please don't put any liquid full substance on the equipment such as vase...
6. Scrap battery have an effect to environment, please do not throw out anywhere, put them into appointed recycle bin.

## Foreword

Thank you for purchasing this product, please read this manual carefully so that you can understand how to operate the system properly. Please keep this manual in a safe place after reading as a reference in the future.

This series of professional wireless microphone system used with high efficient, low consumption RF transmission and super sensitive RF receiving technique, apply an independent.

developed dynamic audio compression, expander circuit, image frequency limiting circuit, multi-detecting squelch circuit, numeral pilot carrier detecting squelch circuit, antenna diversity receiving circuit, switch impact noise defeat circuit, resist reverberation circuit, graded output control ect...Adopt computer EDA simulating on line auxiliary design and strict quality control to gain the excellent function for each system.

## System Introduction

This series of wireless system will give you the super audio quality and eximious freedom on moving. This manual cover each of system: The Vocal Artist-UHF The Presenter-UHF, The Headset-UHF and The Guitarist-UHF.

## System Feature

1. Diversity circuit with automatic signal selection to improve the receiving effect, effectively clean up the signal blind spot in using.
2. Design with an antenna signal splitter of eight channel inside, extremely balance to distribute the RF signal from antenna to each receiving module evenly.
3. To determine the final choice for analysis of signal strength and signal quality by squelch circuit design, effect to reduce the pulse train of RF noises in using environment.
4. One 100mA/10.5V DC voltage is output from two antenna input, supplied for the using of external antenna amplifier to extend the system receiving distance.
5. Design with four XLR output connectors in 0dB output and input, they can be connected to the external audio equipment.
6. Bodypack transmitter with selecting switch for Lavalier/Headset/Guitarist, suitable for the system using demand.
7. Supply the power to four receiver modules independently for exclusive use.
8. ELA standard 19 inch full metal housing.
9. Separate modules design in draw easily, convenient to use and easy to repair and upgrade.
10. Adopt precise high frequency radiant protection technique, high sensitivity, low noise and harmonic radiation, long receiving distance, steady receiving

## System type

1. The Vocal Artist-UHF is a handheld system designed for singers who desire the high quality of microphone and the freedom of wireless performance.
2. The Presenter-UHF is a bodypack system designed for public speakers who prefer an inconspicuous, handfree lavalier microphone.
3. The Headset-UHF is a bodypack system designed for users in physically active applications who desire the freedom of hand-free microphone.
4. The Guitarist-UHF is a bodypack system designed for users with electric guitars, basses and other electric instrument.

## WR400&4 Front&rear panel function/ instruction

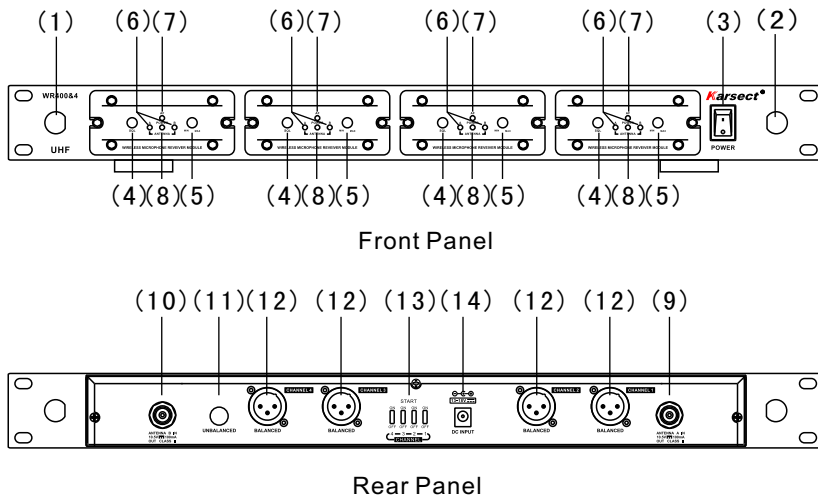

1. Front Antenna Hole A: Move the receiving antenna to front panel.
2. Front Antenna Hole B: Move the receiving antenna to front panel.
3. Power Switch: Power ON/OFF the receiver.
4. Squelch Adjusting Knob: Adjust the squelch sensitivity of receiver to strengthen the signal quality or system receiving distance. This knob is factory pre-set, normally no further adjustment is required.
5. Volume Adjusting knob: Adjust the volume output of receiver.
6. Antenna Diversity Signal Indicators: indicate the receiver signal is from antenna "A" or "B" .
7. AF Peak Indicator: Indicate the receiver audio signal strength.
8. Power Indicator: Indicate the receiver power state.
9. Antenna "A" (TNC) :Receiverd the RF signal from transmitter.
10. Antenna "B" (TNC) :Receiverd the RF signal from transmitter.
11. 1/4' Phone Jack Audio Output Connector (Unbalanced impedance) : An unbalanced audio cable with 1/4' phone jack can be connected to the input of amplifier/audio mixer.
12. XLR Audio Output Connector (Balanced Output) : A balanced audio cable with XLR plug can be connected to the input of amplifier/audio mixer.
13. Power Switch For Each Receiving Module: Power on the receiving modules separately.
14. Power Jack: Connect the Power AC/DC adapter to receiver.

## HT400 Transmitter Function/Instruction

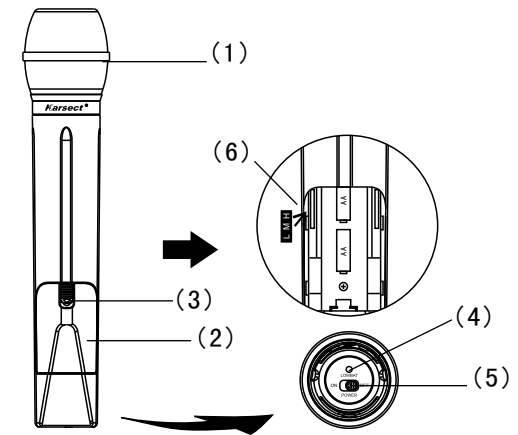

1. Grille: Protects the cartridge and help reducing the breath sounds and wind noise.
2. Battery Cover: Open it to install the battery.
3. Battery Cover Lock: lock or unlock the battery cover.
4. Low Battery Indicator: Red light glows when it is lack of power and should renew the battery.
5. Power Switch: Power ON/OFF the transmitter.
6. Gain Adjustment: Adjust the transmitter audio input gain in high, middle or Low levels

## PT400 Transmitter Function/Instruction

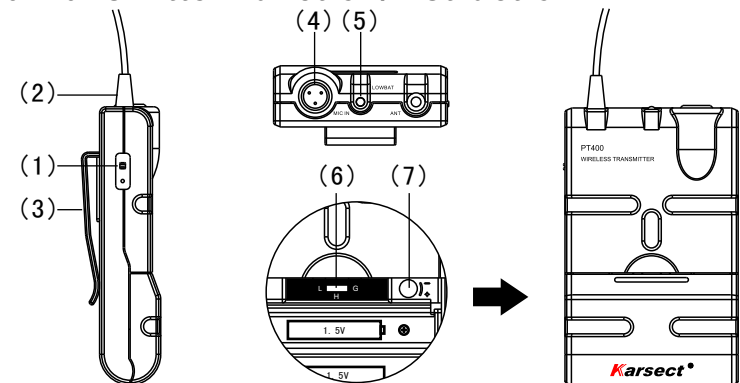

1. Power Switch: Power ON/OFF the transmitter.
2. Antenna: Transmit the RF signal of transmitter.
3. Belt Clip: Gird the transmitter to the belt or guitar strap.
4. Audio Input Jack: It is TAF 3 pins connector, it is suitable for lavalier system/ Headset system/guitar and instrument system.
5. Low Battery Indicator: Red light glows when it is lack of power and should Renew the battery.
6. State Setting Switch: Set the using state to lavalier system/headset system/ guitar system.
7. Gain Adjustment: Adjust the transmitter audio input gain.

## Transmitter Battery Installation

1. Battery Installation of Handheld Microphone: Unlock the battery cover and take it out, insert the supplied batteries into battery jar in polarity and cover the battery cover, then lock.

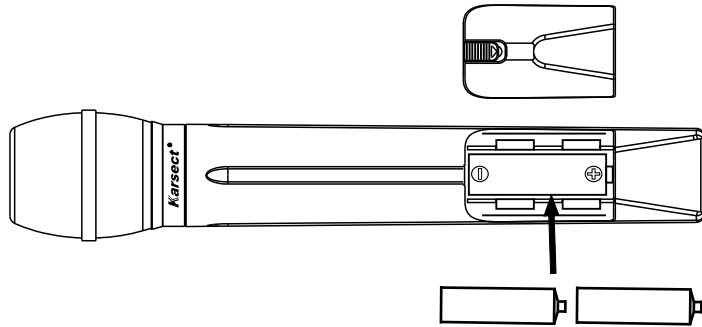

2. Battery Installation of Bodypack Transmitter: Press down the lock on battery cover open it, insert the supplied batteries into battery jar in polarity and close to lock battery cover.

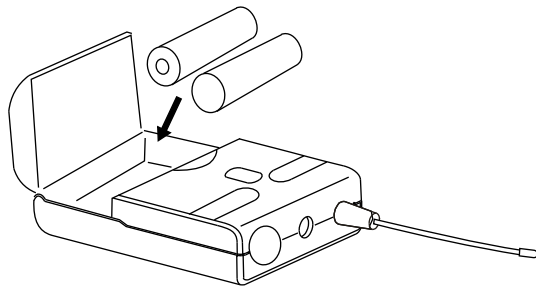

## Three Types of Bodypack Transmitter Connection

1. Lavalier Microphone Connection: Connect the TAF 3 pins connector of supplied lavalier cable to the TAF3 pins connecting jack of transmitter (Shown as below), set the transmitter work state in wireless lavalier system .

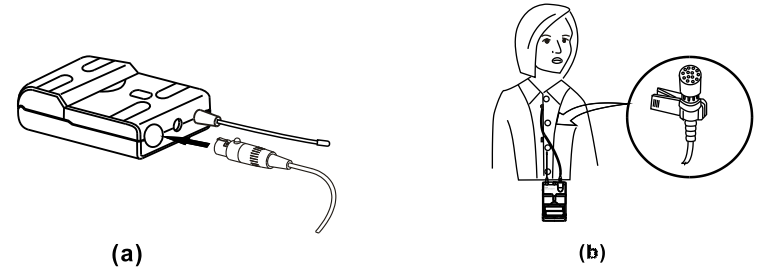

2. Headset Microphone Connection: Connect the TAF 3 pins connector of supplied headset microphone to the TAF3 pins connecting jack of transmitter (Shown as below), set the transmitter work state in wireless headset system .

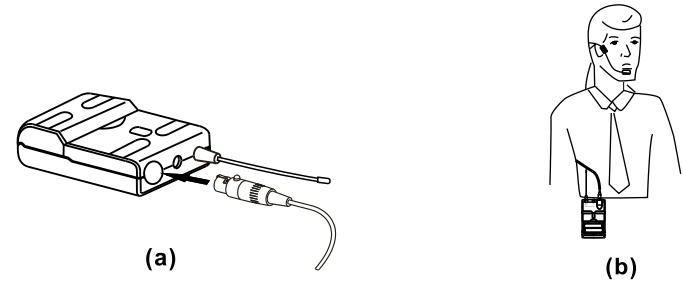

3. Guitarist Microphone Connection: Connect the TAF 3 pins connector of supplied guitar cable to the TAF3 pins connecting jack of transmitter (Shown as below), set the transmitter work state in wireless guitarist system.

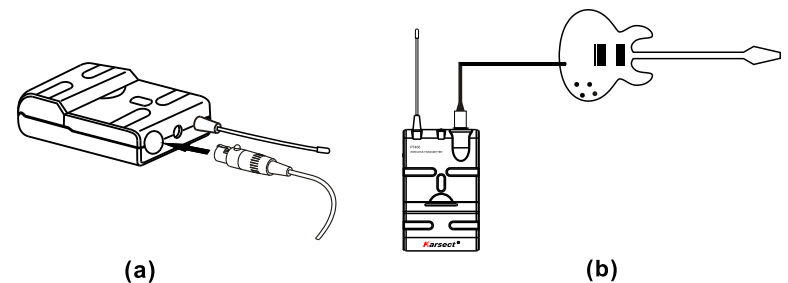

## System Connection

1. Receiver Power Connection: Connect the DC connector of supplied AC/DC adapter into the DC power input of receiver. Plug the AC input connector into an AC120/60Hz or AC220V/50Hz outlet. (Shown as below)

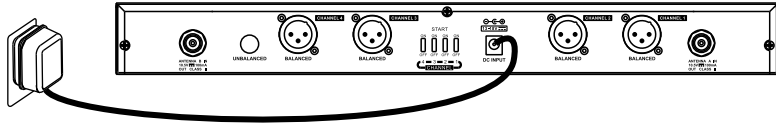

2. Antenna Connection: Install two antennas to the antenna input of receiver respectively, keep the position of antenna at a 45 angle from vertical, then tighten the screw. (Shown as below)

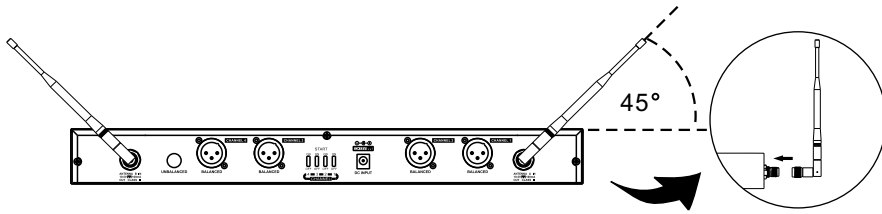

3. Audio Connection: Connect the corresponding output of receiver by supplied 1/4" phone jack audio cable or your XLR cable to the input of power amplifier or mixer. (Shown as below)

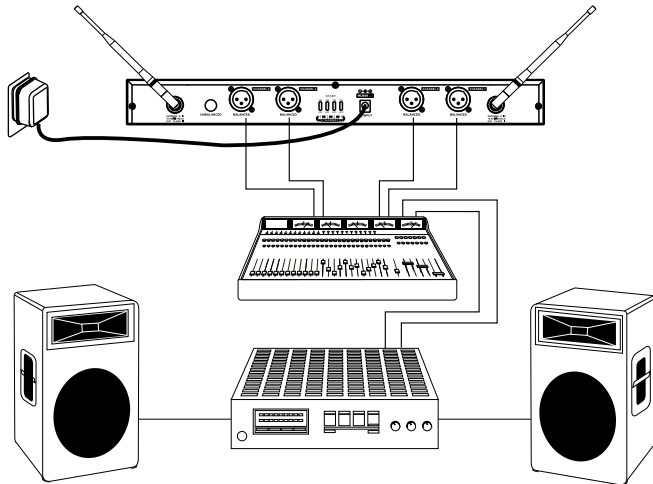

## Receiver Installation in 19 Inch Equipment Rack

Put the receiver into a suitable position of 19 inch equipment rack, tighten with four fixed screw so that the receiver can be installed to the rack easily.

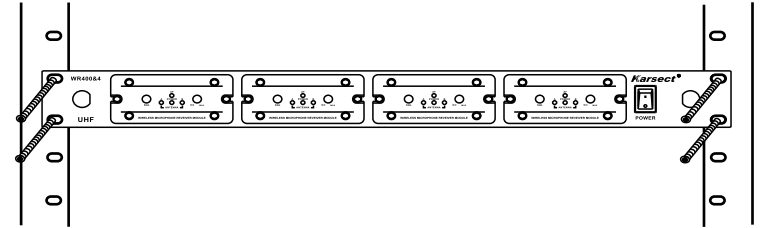

## Specification

### System specification.

1. Frequency range: 720.00-865.00MHz (Available frequencies depend on the applicable regulations in the country where the system is used)
2. Frequency stability:  $\pm 15$ ppm
3. S/N Ratio:  $>85$ dB
4. Total harmonic distortion(THD):  $<0.5\%$
5. Frequency response: 50Hz--15KHz ( $\pm 2$ dB)
6. Audio output level: 360mV
7. Working distance: 100 meters (In good condition)
8. Operating temperature:  $-10\sim 50$  degree

### Receiver specification

1. Sensitivity:  $>-105$ dBm (S/N:  $-12$ dB/15KHz)
2. Border upon channel rejection:  $>75$ dB
3. RF image spurious rejection:  $>75$ dB
4. Power requirement: 13--15V/DC
5. Power consumption:  $<30$ W
6. Size: 48 x 21 x 5 cm

### Handheld transmitter specification

1. RF power: 10dBm (50  $\Omega$ )
2. Harmonic rejection:  $>-60$ dBc
3. Max. frequency deviation:  $>65$ KHz
4. Current consumption:  $<95$ mA (2AA)
6. Cartridge: Dynamic/Cardioid
7. Battery: 2XAA (Alkaline battery)
8. Battery life: Approx. 8 hours (1800mAh)

### Bodypack transmitter specification

1. RF power: 10dBm (50 $\Omega$ )
2. Harmonic rejection:  $>-60$ dBc
3. Max. frequency deviation:  $>65$ KHz
4. Current consumption:  $<95$ mA (2AA)
5. Cartridge: Condenser/Cardioid
6. Battery: 2XAA (Alkaline battery)
7. Battery life: Approx. 8 hours (1800mAh)