

## Tach NXT SAR Analysis

RECORD ID	GTR-12-0333-A	RELEASE DATE	05-SEPT-2012	TYPE	RECORD – LEVEL 4	FORM	FOR-0043
The information in this document is proprietary to Micro Systems Engineering, Inc. It may not be used, reproduced or disclosed without prior approval of Micro Systems Engineering, Inc.							

## Table of Contents

<b>1</b>	<b>PURPOSE .....</b>	<b>3</b>
<b>2</b>	<b>REGULATORY CONCLUSION.....</b>	<b>3</b>
<b>3</b>	<b>APPLICABILITY .....</b>	<b>3</b>
<b>4</b>	<b>DOCUMENT HISTORY.....</b>	<b>3</b>
<b>5</b>	<b>REFERENCES.....</b>	<b>3</b>
<b>6</b>	<b>DEFINITIONS .....</b>	<b>3</b>
<b>7</b>	<b>TEST EQUIPMENT.....</b>	<b>3</b>
7.1	VARIANTS OF THE TACH NXT ICD .....	4
<b>8</b>	<b>SPECIFIC ABSORPTION RATE (SAR) ANALYSIS.....</b>	<b>5</b>
8.1	METHOD OF SAR ANALYSIS.....	5
8.2	RF TRANSMITTER PARAMETERS.....	7
8.3	SAR COMPUTATIONAL ANALYSIS.....	8
8.4	WORST-CASE SAR EXPOSURE.....	10
<b>9</b>	<b>SAR SUMMARY .....</b>	<b>13</b>
<b>10</b>	<b>APPROVAL AND SIGNATURES.....</b>	<b>13</b>

## 1 PURPOSE

The purpose of this report is to document the Specific Absorption Rate (SAR) computational analysis of the Biotronik Tach NXT implantable cardioverter defibrillator (ICD).

## 2 REGULATORY CONCLUSION

The Tach NXT implant, employing an ultra-low power RF transmitter, complies with the SAR regulatory limits specified in 47 CFR 95.1221, §2.1093, and §1.1310.

The Biotronik Tach NXT's maximum worst-case SAR is **10.34 mW/kg**, averaged over 1 gram of tissue. The regulatory limit specified in 47 CFR 2.1093 is **1.6 Watts/kg**, averaged over 1 gram of tissue. As such, the implant's SAR level complies with the FCC regulatory limit with a margin of **21.9 dB**.

## 3 APPLICABILITY

This report is applicable to the Tach NXT family of ICD's that use the same MedRadio RF transmitter circuitry and antenna structures noted in this report.

## 4 DOCUMENT HISTORY

Ver. A      5-September-2012      Initial Release

## 5 REFERENCES

- 1) 47 CFR 1.1310, Radio Frequency Radiation Exposure Limits.
- 2) 47 CFR 2.1093, Radio Frequency Radiation Exposure Evaluation: Portable Devices
- 3) 47 CFR 95.1221, RF Exposure
- 4) RF Safety: Body Tissue Dielectric Properties, FCC web site: <http://transition.fcc.gov/oet/rfsafety/dielectric.html>

## 6 DEFINITIONS

Conducted Measurements	Electrical measurements made using hardwired connections to the DUT
DUT	Device Under Test
FDTD	Finite Difference Time Domain
MedRadio	Medical Device Radiocommunication Service
NIST	National Institute of Standards and Technology
RF	Radio Frequency
SWR	Standing Wave Ratio

## 7 TEST EQUIPMENT

The following equipment was used to perform the tests outlined in this report. All test equipment used in the testing was calibrated, traceable to NIST, at the time the measurements were performed.

ITEM DESCRIPTION	MANUFACTURER	MODEL	SERIAL NUMBER
Implant module (DUT)	Biotronik	Tach NXT	4011075426
RF Spectrum Analyzer	Rohde & Schwarz	FSL 616	100288
RF Power Meter Sensor	Agilent	8481A	MY41095529
Power Meter/Freq Counter	Agilent	53147A	US40470964
RF Network Analyzer	Agilent	8753ES	US39170321
3.5 mm Calibration Kit	Agilent	85033D	3423A04725

GTR-12-0333-A

### Tach NXT SAR Analysis

The information in this document is proprietary to Micro Systems Engineering, Inc. It may not be used, reproduced or disclosed without prior approval of Micro Systems Engineering, Inc.

## 7.1 VARIANTS OF THE TACH NXT ICD

To deliver optimal cardiac therapy to the patient, the Tach NXT ICD will be produced in two variants, marketed, and sold, with the product name llesto. These ICDs have different lead socket arrangements, and slightly different antenna structures. Both variants use exactly the same MedRadio RF transceiver, but have slightly different loop antenna structures to accommodate the difference in physical placement of the lead sockets in the header. Photographs of the two ICDs are shown in Figures 7.1-1 and 7.1-2.

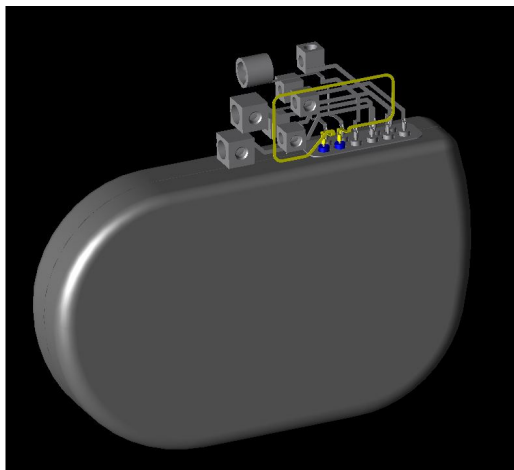


**Figure 7.1-1 Tach NXT with a five lead header.**

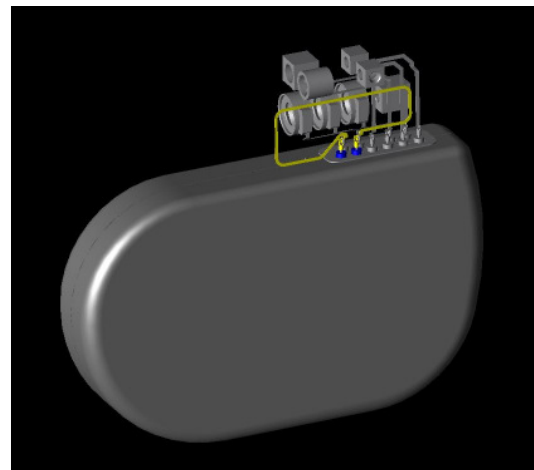


**Figure 7.1-2 Tach NXT with a three lead header.**

The CAD models of the two ICD variants are shown in Figures 7.1-3 and 7.1-4. The epoxy header was removed for clarity, and the antenna structures are highlighted in yellow. A SAR analyses was performed for both header/antenna structures, and the results are detailed below.



**Figure 7.1-3 Antenna structure #1.**



**Figure 7.1-4 Antenna structure #2.**

## 8 SPECIFIC ABSORPTION RATE (SAR) ANALYSIS

Biotronik ICD's utilize an ultra-low power RF transmitter to send a patient's cardiac medical condition to a physician for evaluation. The amount of radiated power absorbed by the human body using this technology can be defined by a measure termed the Specific Absorption Rate (SAR). ANSI and the IEEE have defined the maximum SAR levels that can be safely used in these applications, and these limits are included in the FCC's regulations for the Medical Device Radiocommunication Service.

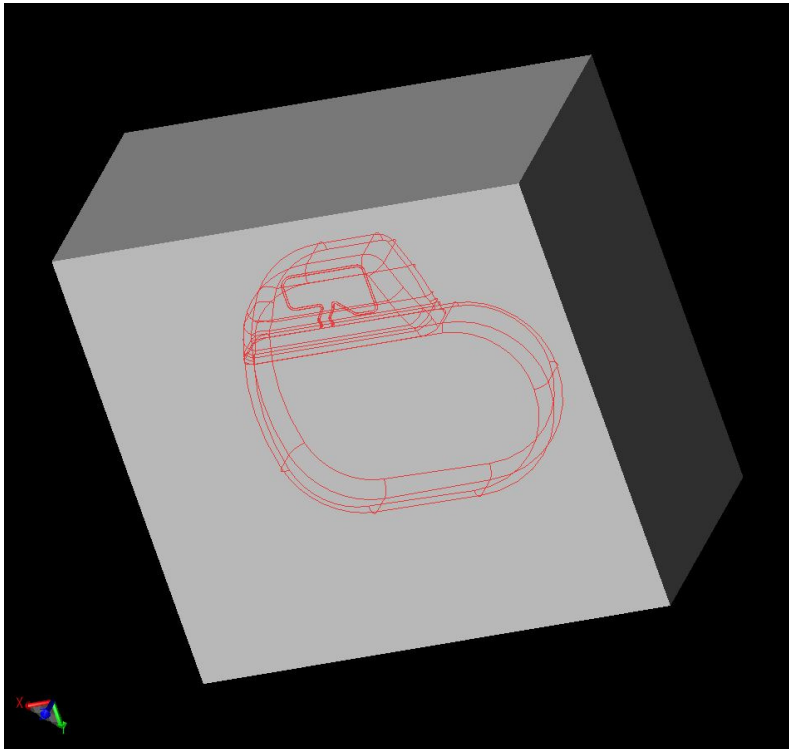
Certification of medical-implant transmitters under the FCC Part 95 MedRadio requires a measurement or Finite Difference Time Domain (FDTD) computational analysis of the SAR associated with the presence of non-ionizing radio frequency transmissions. This report details the SAR computational analysis for the ultra-low power RF transmitter employed in the Tach NXT implant.

### 8.1 METHOD OF SAR ANALYSIS

The computational software used for this FDTD SAR analysis was Remcom XFDTD Version 7.2.3.4. This software was used to convert a Biotronik 3-dimensional CAD engineering model of the implant to a 3D rectangular-grid FDTD computational space.

Adaptive cell-size meshing was employed in the FDTD computational space to achieve accurate modeling while also maintaining a reasonable limit on the computational memory requirements. To accurately model the SAR, a maximum cell size of 0.5 mm was used; except in the region of the antenna structure where the cell size was further reduced to 0.03 mm. As this cell size is extremely small, it is not practical to include a model of the upper human torso in the analysis. However, since previous experience using XFDTD modeling has shown that the region of maximum SAR is concentrated very near the antenna structure, the region surrounding the ICD was modeled using a material simulating the dielectric properties of human muscle at 403.5 MHz. As such, the computational model used in this study was restricted to 2 cm of muscle tissue surrounding the implant, and this resulted in a computational analysis encompassing greater than 69 million Yee cells. To eliminate reflections at the boundary of the modeled space, the region beyond the meshed volume was modeled using perfectly matched layers (PML absorbing boundary).

Figure 8.1-1 shows a 3D rendering of the SAR computational space representing a volume of muscle completely surrounding the ICD. The outline of the ICD, and the loop antenna in its header, can be clearly identified. The entire computational space encompasses 10.5 cm x 10 cm x 5.5 cm, or approximately 577.5 cm<sup>3</sup>. This volume is more than sufficient for computing 1-gram average SAR levels as required by the FCC.

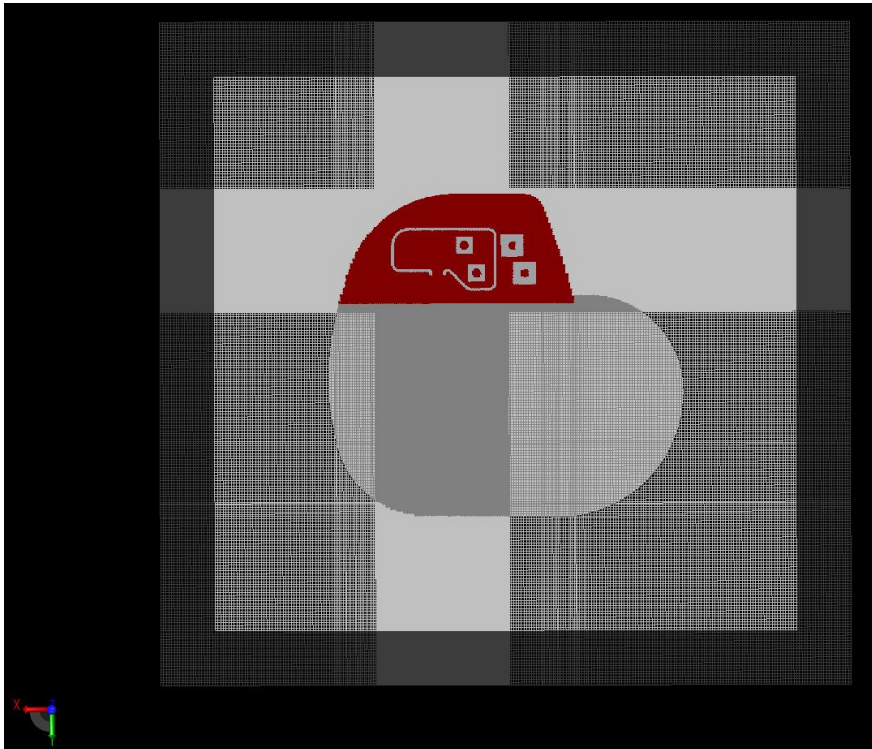


**Figure 8.1-1 Tach NXT embedded in tissue for the SAR analysis.**

The use of a small cell size allowed all the elements of the header and antenna structure to be realized and accurately modeled with “non-thin” FDTD elements. The muscle tissue electrical properties used in the SAR analysis were obtained from the FCC’s web site for RF Safety: Body Tissue Dielectric Properties. In accordance with the dielectric properties reported on the FCC web site for average human muscle at 403.5 MHz, the biological tissue was modeled with a dielectric constant of 57.9 and a conductivity of 0.82 S/m. The implant case material was modeled as titanium, and the antenna loop structures were modeled as stainless steel. The relative dielectric constant of the epoxy header was 3.24, and its conductivity was 0.0034 S/m.

The electrical parameters of the implant’s RF transmitter (driving the antenna structures), were determined by the measurements outlined in Section 8.2.

Figure 8.1-2 below shows one layer in the meshed problem space used in the SAR analyses. The SAR computational space encompassed 324 such layers. The light grey bands in the figure, which intersect throughout the loop antenna region of the implant, are volume spaces where the adaptive meshing is reduced to 0.03 mm.



**Figure 8.1-2 One layer of the meshed XFDTD volume space.**

The SAR analysis was performed at the center frequency of the MedRadio band (403.5 MHz). In the MedRadio band, the electrical properties of biological tissue are described by a dipolar mechanism. The dipolar region is characterized by slowly changing permittivity and conductivity, with many tissue types exhibiting a Cole-Cole behavior. Thus, it is reasonable to expect similar SAR results over the relatively narrow, 3 MHz wide, MedRadio band.

## 8.2 RF TRANSMITTER PARAMETERS

The Thevenin equivalent circuit of ICD's RF transmitter was determined by measuring the implant transmitter's RF output power and output impedance. The output power, measured using an RF power meter, was -2.21 dBm at 403.65 MHz. The transmitter's output impedance ( $Z_{out}$ ), measured at 403.65 MHz using an RF network analyzer, was  $Z_{out} = 58.1 - j 139.4$  Ohms. This is equivalent to a 58.1 Ohm resistor in series with a 2.83 pF capacitor. Using these measurements, the equivalent transmitter open-circuit output voltage was computed to be 0.865 volts peak.

The source model in the analyses consisted of a continuous wave (CW) signal at 403.65 MHz with an amplitude of 0.865 Volts peak, in series with a 58.1 Ohm resistor and a 2.83 pF capacitor. Figure 8.2-1 shows the Thevenin equivalent circuit of this source model.

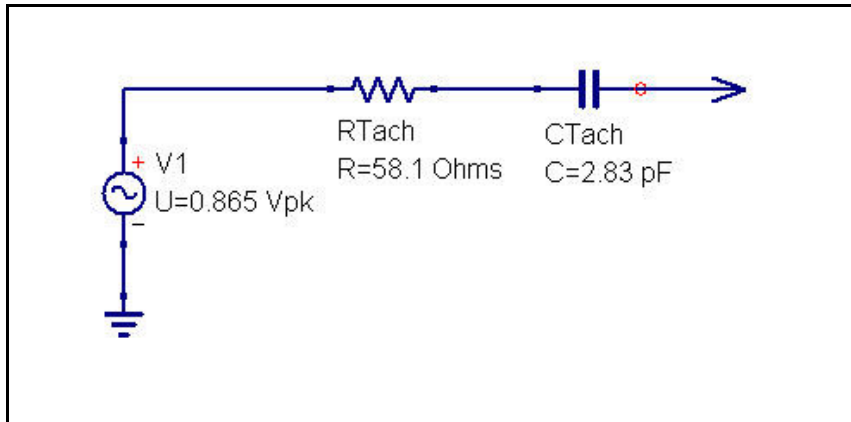
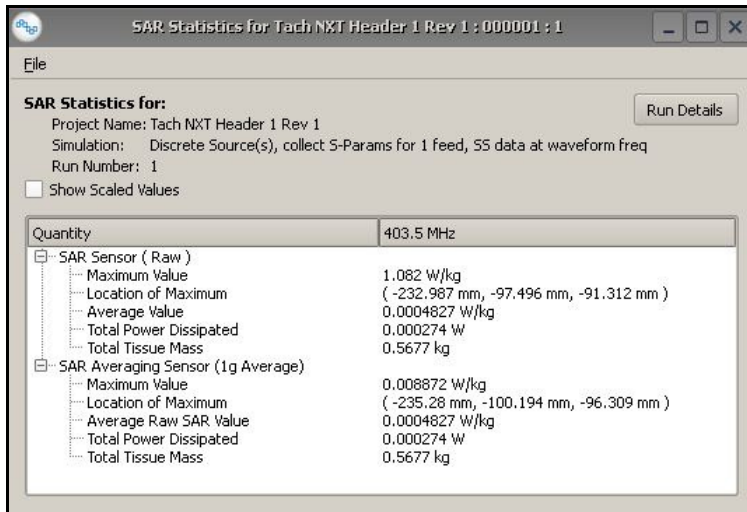


Figure 8.2-1 Thevenin equivalent circuit of Tach NXT RF transmitter.

### 8.3 SAR COMPUTATIONAL ANALYSIS

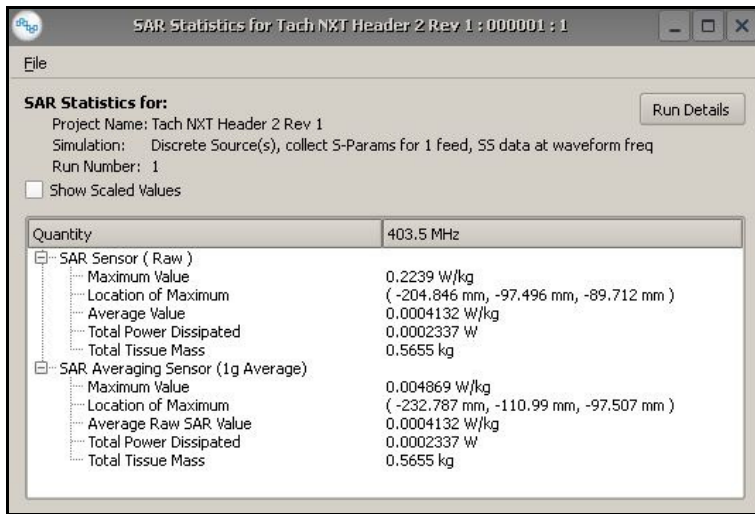
Figures 8.3-1 and 8.3-2 summarize the computed SAR analysis statistics for antenna structures #1 and #2 respectively. The important result, and the one regulated by the FCC, are the results labeled “**SAR Averaging Sensor (1g Average), Maximum Value**”. The results labeled “SAR Sensor (Raw), Maximum Value” are of no significance since the value is a function of the mesh size used in the analysis. Remcom XFDTD software only reports its value for reference purposes.



Quantity	403.5 MHz
[-] SAR Sensor ( Raw )	
Maximum Value	1.082 W/kg
Location of Maximum	( -232.987 mm, -97.496 mm, -91.312 mm )
Average Value	0.0004827 W/kg
Total Power Dissipated	0.000274 W
Total Tissue Mass	0.5677 kg
[+] SAR Averaging Sensor (1g Average)	
Maximum Value	0.008872 W/kg
Location of Maximum	( -235.28 mm, -100.194 mm, -96.309 mm )
Average Raw SAR Value	0.0004827 W/kg
Total Power Dissipated	0.000274 W
Total Tissue Mass	0.5677 kg

Figure 8.3-1 Summary of SAR statistics for antenna structure #1.

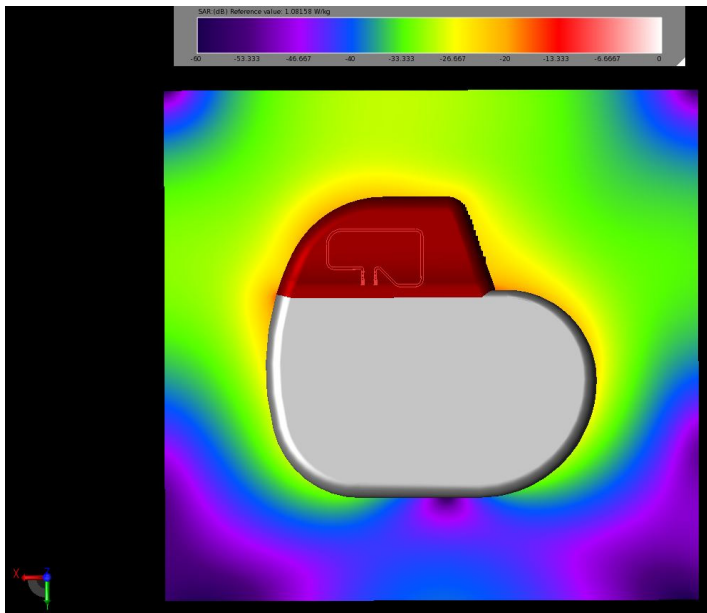




**Figure 8.3-2 Summary of SAR statistics for antenna structure #2.**

Figure 8.3-1 shows that the maximum 1-gram averaged SAR for antenna structure #1 is 8.872 mW/kg. Figure 8.3-2 shows the maximum SAR for antenna structure #2 is 4.869 mW/kg. This is approx. 45% less than antenna #1. Since antenna structure #1 resulted in the greatest SAR, all further analysis in this report will pertain to this implementation.

The intensity of the SAR distribution around the implant with antenna #1 is shown in Figure 8.3-3. The distribution shown in the figure corresponds to the mesh layer reported by Remcom XFDTD that has the highest 1-gram averaged SAR. It is readily apparent from the analysis that the maximum SAR exposure occurs in tissue material very close to the implant's loop antenna structure.



**Figure 8.3-3 SAR distribution in tissue surrounding the implant.**

## 8.4 WORST-CASE SAR EXPOSURE

This section details the worst-case SAR exposure analysis for the Tach NXT ICD. The uncertainty analysis described below considers the effects of the errors in the network analyzer measurement used to determine the transmitter's output impedance, the amplitude accuracy of the power meter used to measure the transmitter's output power, and the uncertainty in the power meter measurement due to the non-ideal return loss of the power meter sensor/transmitter connection. Each of these 3 error types will be summarized and the worst-case sum of these effects will be used to modify the SAR exposure results. Of interest here is the possible increase in SAR exposure due to instrumentation errors.

### (I) Network Analyzer Uncertainty:

The Tach NXT transmitter output impedance was measured using an Agilent 8753ES vector network analyzer. The output impedance had a nominal reflection coefficient of  $|\Gamma| = 0.7916$ . The 8753ES was calibrated for a 1-port S11 measurement using an open, short, and load standard from an Agilent 85033D 3.5 mm Calibration Kit.

The measurement error associated with a reflection calibration is found in the specifications for the Agilent 8753ES, and at 400 MHz for  $|\Gamma| = 0.7916$  is:

Uncertainty for $ \Gamma $	+/- 0.011
Uncertainty for $\text{Arg}(\Gamma)$	+/- 1 degree

### (II) Power Meter Amplitude Uncertainty:

The amplitude measurement uncertainty specifications for an Agilent 53147A power meter and Agilent 8481A power sensor, for the measurement conditions of  $-2.21$  dBm in the MedRadio frequency band, are summarized below:

Instrumentation Accuracy	+/- 0.02 dB
Reference Accuracy	+/- 0.03 dB
Overall Uncertainty	+/- 0.05 dB

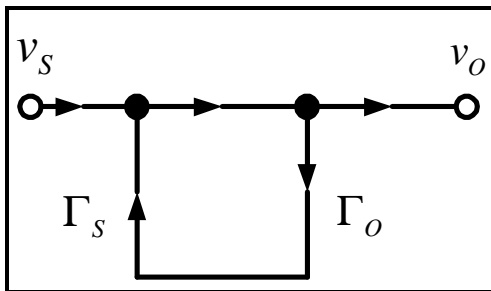
### (III) Power Sensor/DUT Mismatch Uncertainty:

The SWR for the Agilent 8481A power sensor over the frequency range of 50 MHz to 2 GHz is shown below:

Maximum SWR	1.10
Maximum Reflection Coefficient	0.048

Figure 8.4-1 shows the signal flow graph for the transmitter impedance measurement. The power transfer function from the source (Tach NXT's transmitter) to the load (RF power sensor) is:

$$\frac{P_o}{P_S} = \frac{(1 - |\Gamma_S|^2)(1 - |\Gamma_o|^2)}{|1 - \Gamma_S \cdot \Gamma_o|^2}$$



**Figure 8.4-1 Signal flow graph of the Tach NXT TX/power meter interface.**

The uncertainty associated with this transfer function (*Microwave Theory and Applications*, page 233, by Stephen Adam, Prentice-Hall) is  $(1 \pm |\Gamma_S| \cdot |\Gamma_O|)^2$

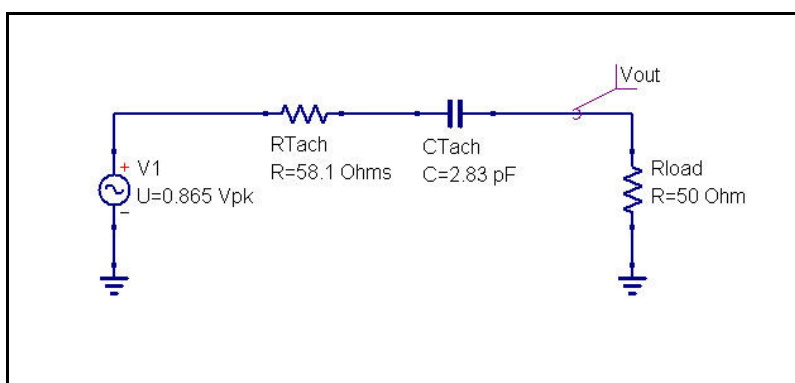
For the Tach NXT transmitter, the nominal value of  $\Gamma_S = 0.7916$ , and for the Agilent 8481A power sensor,  $\Gamma_O = 0.048$ .

The uncertainty is then:  $\Delta Error_{(dB)} = 20 \log_{10}(1 \pm |0.7916| \cdot |0.048|)$

Hence:

Maximum Mismatch Uncertainty, $\Delta Error_{(dB)}$	+ 0.324 dB
Minimum Mismatch Uncertainty, $\Delta Error_{(dB)}$	- 0.336 dB

Figure 8.3.2 shows the equivalent circuit of the Tach NXT RF transmitter driving a nominal 50 Ohm load (representing the Agilent 8481A power sensor). This model is used to compute the transmitter's equivalent open-circuit source voltage ( $v_S$ ).



**Figure 8.4-2 Determination of equivalent source voltage**

The nominal source impedance, represented by the components R and jX, were determined using the network analyzer measurement detailed above. The transmitter's equivalent output impedance is 58.1  $\Omega$  resistance in series with  $-j139.4 \Omega$  reactance (equivalent to a capacitance of 2.83 pF).

Referring to Figure 8.4-2, the nominal output voltage V1, can be computed from the expression below:

$$|V1| = \sqrt{\frac{P_O}{50} \cdot ((50 + R_{Tach})^2 + X_{Tach}^2)}$$

For the nominal values of measured source impedance and measured output power (-2.21 dBm), the nominal magnitude of the Tach NXT transmitter's equivalent open-circuit source voltage (V1) is 0.865 Volts peak.

To complete the analysis, we apply the uncertainty of the power meter amplitude measurement, and the uncertainty of the network analyzer impedance measurement, to the equivalent circuit, and compute the worst-case open-circuit source voltage.

First, considering only the uncertainty in the power measurement, the worst-case maximum power can be computed by adding the overall power meter uncertainty of +0.05 dB and the worst-case mismatch uncertainty of +0.397 dB.

The worst-case maximum output power is:  $P_O = -2.21 \text{ dBm} + (0.05 + 0.324) \text{ dB}$   
 $P_O = -1.836 \text{ dBm}$   
 $P_O = 655. \mu\text{W}$

Next, noting that the largest equivalent open-circuit source voltage (V1) occurs when the values of  $R_{Tach}$  and  $X_{Tach}$  are maximized; the next step is to determine when these maximums occur. Maximum values for these components occur when the uncertainty in  $|\rho|$  is +0.011 and the phase angle is +1 degrees. For this case  $R_{Tach} = 58.3 \Omega$  and  $X_{Tach} = -j(145.1) \Omega$ .

Substituting all of the parameter changes to compute the worst-case (largest) value of source voltage is:

$$|V1| = \sqrt{\frac{665 \mu\text{W}}{50} \cdot ((50 + 58.3)^2 + 145.1^2)} = 0.660 V_{\text{RMS}} = 0.934 V_p$$

This is an increase of:  $20 \cdot \log_{10} \left( \frac{0.934}{0.865} \right) = 0.665 \text{ dB}$ .

Since the SAR exposure is dependent on the square of the electric field component, and the dielectrics modeled are all isotropic and linear, the potential increase in the SAR is **0.665 dB**.

As shown in Figure 8.3-1, the SAR exposure was computed using Remcom's XFDTD with the nominal values of the transmitter's source impedance and source voltage. Since the worst-case SAR exposure was found to be 0.665 dB greater than the nominally computed value of 8.872 mW/kg, the worst-case SAR is **10.34 mW/kg** (1 gram averaged).

The 1 gram averaged SAR level of 10.34 mW/kg is 21.9 dB below the FCC's limit.

## 9 SAR SUMMARY

The following is a summary of the Tach NXT SAR analyses reported in this document.

1. Two SAR analyses were performed – one for each variant of the Tach NXT ICD.
2. The two Tach NXT physical models used in the SAR analyses were derived directly from Biotronik 3-dimensional engineering CAD files.
3. The SAR analyses were performed using the Finite Difference Time Domain (FDTD) method as required by the FCC. The FDTD simulation software used in the analyses was Remcom Bio-pro XFDTD version 7.2.3.4
4. The SAR analyses were performed with the implant surrounded by a cube of material with dielectric properties identical to human muscle tissue at 403.5 MHz ( $\epsilon_r = 57.9$  and  $\sigma = 0.82$  S/m). The human muscle dielectric properties were obtained from the FCC OET web site for RF Safety: Body Tissue Dielectric Parameters Tool.
5. The simulated muscle tissue surrounding the implant extended beyond the implant by 2 cm. The region extending beyond the simulated muscle tissue was modeled as a perfectly absorbing boundary.
6. The SAR analyses were performed using adaptive meshing to resolve antenna features as small as 0.03 mm.
7. Remcom XFDTD reported this mesh size would result in accurate modeling to 59.96 GHz.
8. Each SAR analysis encompassed a volume space comprised of approximately 69 million cells.
9. The time step in the FDTD simulation was 52 fs.
10. The analyses were performed using a sinusoidal source at 403.5 MHz (the center frequency of the 402 MHz to 405 MHz MedRadio band).
11. The transmitter output power was measured using a calibrated Agilent RF power meter.
12. The transmitter output impedance was measured using a calibrated Agilent RF network analyzer.
13. The maximum SAR exposure occurred in the immediate vicinity of the implant, well within the volume of the simulated muscle tissue.
14. The SAR simulation attained better than  $-30$  dB convergence.
15. A worst-case analysis was performed on the larger of the two reported SAR results. The worst-case SAR was computed for the worst-case RF transmitter power and output impedance. This added 0.665 dB to the computed SAR exposure.
16. The worst-case 1-gram averaged SAR is **10.34 mW/kg**.
17. The Tach NXT ICD worst-case 1-gram averaged SAR is below the FCC regulatory limit of 1.6 W/kg by a margin of **21.9 dB**.

## 10 APPROVAL AND SIGNATURES

**Brian Sutton** **5-Sept-2012**  
ORIGINATOR/DATE

**Paul Stadnik** **5-Sept-2012**  
CHECKED AND APPROVED BY

GTR-12-0333-A

Tach NXT SAR Analysis

The information in this document is proprietary to Micro Systems Engineering, Inc. It may not be used, reproduced or disclosed without prior approval of Micro Systems Engineering, Inc.

Confidentiality Class  
Confidential

Type  
Document – Level 3

Form No.  
FOR-0043

Rev.  
B

Change Notice  
12-0252

Pages  
13/13