



RADIO REPORT FCC 47 CFR Part 95I Medical Device Radiocommunication Service (MedRadio) ISED RSS-243 Medical Devices Operating in the 401 – 406 MHz Frequency Band	
Report Reference No	G0M-1908-8377-TFC95IMR-V02
Testing Laboratory	Eurofins Product Service GmbH
Address	Storkower Str. 38c 15526 Reichenwalde Germany
Accreditation	 <p>DAkKS - Registration number : D-PL-12092-01-03 (ISED) ISED Testing Laboratory site: 3470A-2 DAkKS - Registration number : D-PL-12092-01-04 (FCC) FCC Filed Test Laboratory, Reg.-No.: 96970</p>
Applicant	BIOTRONIK SE & Co. KG
Address	Woermannkehre 1 12359 Berlin GERMANY
Test Specification	According to FCC/ISED rules
Standard	47 CFR Part 95I RSS-243, Issue 3, 2010-02 RSS-Gen, Issue 5, Amendment 1, 2019-03
Non-Standard Test Method	None
Equipment under Test (EUT):	
Product Description	CardioMessenger Smart / Telemonitoring System
Model(s)	CardioMessenger Smart 4G
Additional Model(s)	None
Brand Name(s)	BIOTRONIK
Hardware Version(s)	CardioMessenger Smart 4G mit LP best. LP1/Telex Smart 4G Rev Cx
Software Version(s)	ULP_HIGH_1_32_0, ULP_LOW_1_13_0, M0B.800004
FCC-ID	QRI-CMSMART4GWW
IC	4708A-CMSMART4GWW
Test Result	PASSED

Test Report No.: G0M-1908-8377-TFC95IMR-V02

 Eurofins Product Service GmbH
 Storkower Str. 38c, D-15526 Reichenwalde, Germany

Possible test case verdicts:		
Required by standard but not tested	N/T	
Not required by standard	N/R	
Not applicable to EUT	N/A	
Test object does meet the requirement	P(PASS)	
Test object does not meet the requirement	F(FAIL)	
Testing:		
Test Lab Temperature	20 - 23 °C	
Test Lab Humidity	32 – 38 %	
Date of receipt of test item	2019-09-17	
Report:		
Compiled by	Wilfried Treffke	
Tested by (+ signature) (Responsible for Test)	Wilfried Treffke	
Approved by (+ signature) (Deputy Head of Lab)	Toralf Jahn	
Date of Issue	2021-08-25	
Total number of pages	97	
General Remarks:		
<p>The test results presented in this report relate only to the object tested.</p> <p>The results contained in this report reflect the results for this particular model and serial number. It is the responsibility of the manufacturer to ensure that all production models meet the intent of the requirements detailed within this report.</p> <p>This report shall not be reproduced, except in full, without the written approval of the Issuing testing laboratory.</p>		
Additional Comments:		

VERSION HISTORY

Version History			
Version	Issue Date	Remarks	Revised By
01	2020-05-26	Initial Release	
02	2021-08-25	Replaced document: G0M-1908-8377-TFC95IMR-V01 Replaced by: G0M-1908-8377-TFC95IMR-V02 Reason: New Issue.	W. Treffke

ABBREVIATIONS AND ACRONYMS

Acronyms	
Acronym	Description
EUT	Equipment Under Test
FCC	Federal Communications Commission
ISED	Innovation, Science and Economic Development Canada
RBW	Resolution bandwidth
RMS	Root mean square
VBW	Video bandwidth
V _{NOM}	Nominal supply voltage

REPORT INDEX

1	Equipment (Test Item) Under Test	6
1.1	Photos – Equipment External.....	7
1.2	Photos – Equipment Internal	10
1.3	Photos – Test Setup.....	13
1.4	Support Equipment.....	14
1.5	Test mode duty cycle	15
1.6	Test Modes	17
1.7	Test Frequencies.....	18
1.8	Sample emission level calculation.....	19
2	Result Summary.....	20
3	Test Conditions and Results.....	21
3.1	Test Conditions and Results - Occupied bandwidth.....	21
3.2	Test Conditions and Results - Emission bandwidth.....	29
3.3	Test Conditions and Results - Frequency stability.....	34
3.4	Test Conditions and Results - Transmitter output power.....	36
3.5	Test Conditions and Results - Band-edge and In-band Emissions	38
3.6	Test Conditions and Results - Transmitter unwanted emissions	40
3.7	Test Conditions and Results - Receiver spurious emissions	42
3.8	Test Conditions and Results - AC power line conducted emissions.....	44
3.9	Test Conditions and Results - System threshold power levels.....	47
3.10	Test Conditions and Results - Monitoring system bandwidth	48
3.11	Test Conditions and Results - Scan cycle time	50
3.12	Test Conditions and Results - Minimum channel monitoring period.....	53
3.13	Test Conditions and Results - Channel access	55
3.14	Test Conditions and Results - Discontinuation of MICS or MEDS session	57
ANNEX A	Transmitter output power	60
ANNEX C	Band-edge and In-band Emissions	68
ANNEX D	Transmitter spurious emissions	76
ANNEX E	Receiver spurious emissions	92

1 Equipment (Test Item) Under Test

Description	CardioMessenger Smart / Telemonitoring System	
Model	CardioMessenger Smart 4G	
Additional Model(s)	None	
Brand Name(s)	BIOTRONIK	
Serial Number(s)	80216078	
Hardware Version(s)	CardioMessenger Smart 4G mit LP best. LP1/Telex Smart 4G Rev Cx	
Software Version(s)	ULP_HIGH_1_32_0, ULP_LOW_1_13_0, M0B.800004	
PMN	CardioMessenger Smart 4G	
HVIN	CardioMessenger Smart 4G	
FVIN	n/a	
HMN	n/a	
FCC-ID	QRI-CMSMART4GWW	
IC	4708A-CMSMART4GWW	
Equipment type	End Product	
Radio type	Transceiver	
Assigned frequency bands	402 - 405 MHz	
Radio technology	MedRadio (MICS) programmer / control transmitter	
Modulation	2-FSK	
Emission designator	F1D	
Number of channels	9	
Channel spacing	300 kHz	
Spectrum access	LBT/AFA	
Number of antenna ports	1	
Antenna	Type	Integrated
	Model	PCB-Antenna
	Manufacturer	BIOTRONIK SE & Co. KG
	Gain	1.91 dBi (by antenna pattern measurement)
Supply Voltage	V _{NOM}	3.70 VDC
	V _{MIN}	3.10 VDC
	V _{MAX}	4.16 VDC
Operating Temperature	T _{NOM}	25 °C
	T _{MIN}	-20 °C
	T _{MAX}	55 °C
AC/DC-Adaptor	Model	GTM96180-1107-2.0
	Vendor	GlobTek, Inc.
	Input	100-240
	Output	5.0 VDC +/-10%
Manufacturer	BIOTRONIK SE & Co. KG Woermannkehre 1 12359 Berlin GERMANY	

1.4 Support Equipment.

Product Type	Device	Manufacturer	Model	Comment
none				
Description:				
AE	Auxiliary Equipment			
SIM	Simulator			
CBL	Connecting Cable			
SFT	Software			
Comment:				

1.5 Test mode duty cycle

1.5.1 Information

Test Information	
Measurement Method	ANSI C63.10 11.6

1.5.2 Requirements

Requirements	
Duty cycle	Duty cycle correction
≥ 98 %	No correction required
< 98 %	Correction required ($10 \times \text{Log}_{10}(1/\text{DC})$)

1.5.3 Setup

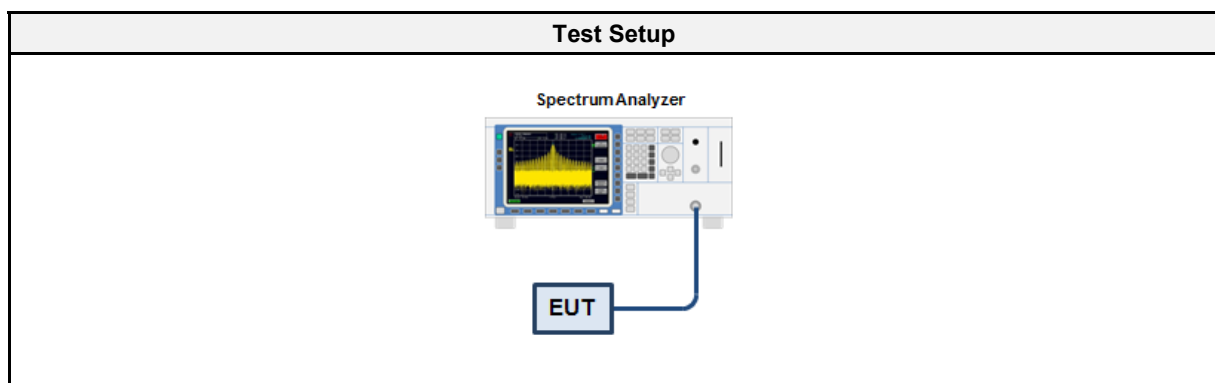

1.5.4 Equipment

Test Equipment					
Description	Manufacturer	Model	Identifier	Cal. Date	Cal. Due
Spectrum Analyzer	R&S	FSU 26	EF01407	2019-07	2020-07

1.5.5 Procedure

Test Procedure
<ol style="list-style-type: none"> 1. EUT set to test mode 2. Span is set to zero span 3. Detector set to peak 4. Sweep time is set long enough to capture at least 5 bursts 5. Envelope peak value of emission spectrum is selected 6. The maximum burst duration T_{ON} is measured using two markers set to the start and the end of the longest burst 7. The minimum idle duration T_{OFF} is measured using two markers set to the start and the end of the shortest idle period 8. The duty cycle is calculated by $\text{DC} = T_{ON} / (T_{ON} + T_{OFF})$ 9. The duty cycle correction is calculated by $\text{DC} = 10 \times \text{Log}_{10}(T_{ON} / (T_{ON} + T_{OFF}))$

1.5.6 Results

Duty Cycle Results		
Mode	Duty Cycle	Correction Factor [dB]
Modulated	1.0 (100%)	0

1.6 Test Modes

Mode	Description
Unmodulated	Mode = Transmit Modulation = None
Modulated	Mode = Transmit Modulation = 2-FSK Power level = maximum
Receive	Mode = Receive Modulation = 2-FSK
Normal	Mode = Regular data connection to companion device
Comment:	

1.7 Test Frequencies

Designator	Mode	Channel	Frequency [MHz]
F1	Tx / Rx	8	402.45
F2	Tx / Rx	0	403.65
F3	Tx / Rx	7	404.85

1.8 Sample emission level calculation

The following is a description of terms and a sample calculation, as appears in the radiated emissions data table. The numbers used in the calculation are for example only. There is no direct correlation to the specific data taken for the product described in this document:

Reading:

This is the reading obtained on the spectrum analyzer in dBµV. Any external preamplifiers used are taken into account through internal analyzer settings.

A.F.:

This is the antenna factor for the receiving antenna. It is a conversion factor, which converts electric fields strengths to voltages, which can be measured directly on the spectrum analyzer. It is treated as a loss in dB. Cable losses have been included with the A.F. to simplify the calculations. The antenna factor is used in calculations as follows:

$$\text{Reading on Analyzer (dB}\mu\text{V)} + \text{A.F. (dB/m)} = \text{Net field strength (dB}\mu\text{V/m)}$$

Net:

This is the net field strength measurement (as shown above).

Limit:

This is the FCC Class B radiated emission limit (in units of dBµV/m). The FCC limits are given in units of µV/m. The following formula is used to convert the units of µV/m to dBµV/m:

$$\text{Limit (dB}\mu\text{V/m)} = 20 \cdot \log(\mu\text{V/m})$$

Margin:

This is the margin of compliance below the FCC limit. The units are given in dB. A negative margin indicates the emission was below the limit. A positive margin indicates that the emission exceeds the limit.

Example only:

Reading + AF	=	Net Reading	:	Net reading - FCC limit	=	Margin
+21.5 dBµV + 26 dB/m		= 47.5 dBµV/m		47.5 dBµV/m - 57.0 dBµV/m		= -9.5 dB

2 Result Summary

FCC 47 CFR Part 95I, 15C, ISED RSS-243, ISED RSS-Gen				
Product Standard Reference	Requirement	Reference Method	Result	Remarks
ISED RSS-243 3.2 ISED RSS-Gen 6.7	Occupied Bandwidth	ANSI C63.10 6.9.3	N/R	Informational only
FCC 95.2573(a) ISED RSS-243 3.6	Emission Bandwidth	ANSI C63.10 6.9.2 ETSI EN 301 839 5.3.2	PASS	
FCC 95.2565 ISED RSS-243 3.3, 5.3	Frequency stability	ETSI EN 301 839 5.3.1	PASS	
FCC 95.2567(a), 95.2569 ISED RSS-243 5.4	Transmitter output power	ETSI EN 301 839 5.3.3	PASS	
FCC 95.2579 ISED RSS-243 3.4, 5.5	Band edge compliance	ANSI C63.10 6.10	PASS	
FCC 95.2579 ISED RSS-243 3.4, 5.5	Transmitter unwanted emissions	ANSI C63.10 6.10	PASS	
ISED RSS-243 3.5, 5.6 ISED RSS-Gen 7.3	Receiver spurious emissions	ANSI C63.10 6.10	PASS	
FCC 15.207 ISED RSS-Gen 7.2, 8.8	AC power line conducted emissions	ANSI C63.10 6.2	PASS	
FCC 95.2559(a)(3),(a)(4) ISED RSS-243 3.6, 5.7.1	System threshold power levels	ETSI EN 301 839 5.3.7.1.3	PASS	
FCC 95.2559(a)(1) ISED RSS-243 3.6, 5.7.2	Monitoring system bandwidth	ETSI EN 301 839 5.3.7.1.4	PASS	
FCC 95.2559(a)(2) ISED RSS-243 3.6, 5.7.3	Scan cycle time	ETSI EN 301 839 5.3.7.1.5	PASS	
FCC 95.2559(a)(2) ISED RSS-243 3.6, 5.7.4	Minimum channel monitoring period	ETSI EN 301 839 5.3.7.1.5	PASS	
FCC 95.2559(a)(5) ISED RSS-243 3.6, 5.7.5	Channel Access	ETSI EN 301 839 5.3.7.1.6	PASS	
FCC 95.2559(a)(5) ISED RSS-243 3.6, 5.7.6	Discontinuation of MICS of MEDS session	ETSI EN 301 839 5.3.7.1.7	PASS	
FCC 95.2559(a)(6) ISED RSS-243 3.6, 5.7.7	Use of the pre-scanned alternate channel	ETSI EN 301 839 5.3.7.1.8	N/A	
Comment:				

Possible Test Case Verdicts	
PASS	Test object does meet the requirements
FAIL	Test object does not meet the requirements
N/T	Required by standard but not tested
N/R	Not required by standard for the test object

3 Test Conditions and Results

3.1 Test Conditions and Results - Occupied bandwidth

3.1.1 Information

Test Information	
Reference	ISED RSS-243 3.2, RSS-Gen 6.6
Measurement Method	ANSI C63.10 6.9.3
Operator	Wilfried Treffke
Date	2019-09-24

3.1.2 Limits

Limits
None (Informational only)

3.1.3 Setup

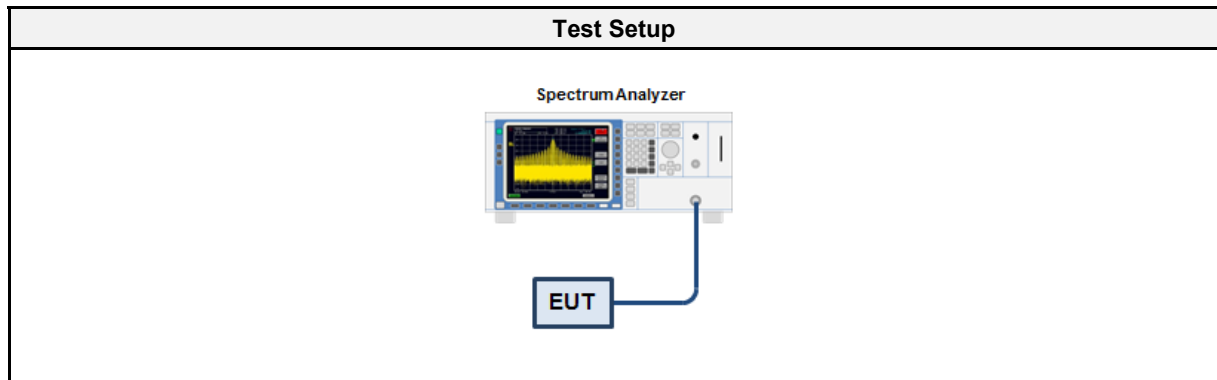

3.1.4 Equipment

Test Equipment					
Description	Manufacturer	Model	Identifier	Cal. Date	Cal. Due
Spectrum Analyzer	R&S	FSU 26	EF01407	2019-07	2020-07

3.1.5 Procedure

Test Procedure
<ol style="list-style-type: none"> 1. EUT transmitter is activated in test mode under normal conditions 2. The spectrum analyzer is set to peak detection and maximum hold with a span twice the emission spectrum 3. The resolution bandwidth is set 1 % to 5 % of the bandwidth 4. The occupied bandwidth (99%) is measured with the build-in analyzer function

3.1.6 Results

Test Results		
Mode	Channel [MHz]	Bandwidth [kHz]
2FSK, 8 kbps	402.45	168.750
2FSK, 8 kbps	403.65	168.525
2FSK, 8 kbps	404.85	167.625
2FSK, 197 kbps	402.45	233.550
2FSK, 197 kbps	403.65	233.325
2FSK, 197 kbps	404.85	234.450
Note	Worst case modulation: 2FSK, 197 kbps	

Occupied Bandwidth RSS-243

Project Number: G0M-1908-8377
 Applicant: BIOTRONIK SE & Co. KG
 Model Description: CardioMessenger Smart / Telemonitorig System
 Model: CardioMessenger Smart 4G
 Test Sample ID: 25555
 Reference Method: RSS-Gen Issue 4 6.6 (Occupied Bandwidth)
 Operational Mode: 2FSK, 8 kbps, Channel: 8, 402.45 MHz
 Operating Conditions: Tnom / Vnom
 Operator: Wilfried Treffke
 Test Site: Eurofins Product Service GmbH
 Test Date: 2019-09-24
 Occupied Bandwidth [kHz]: 168.750

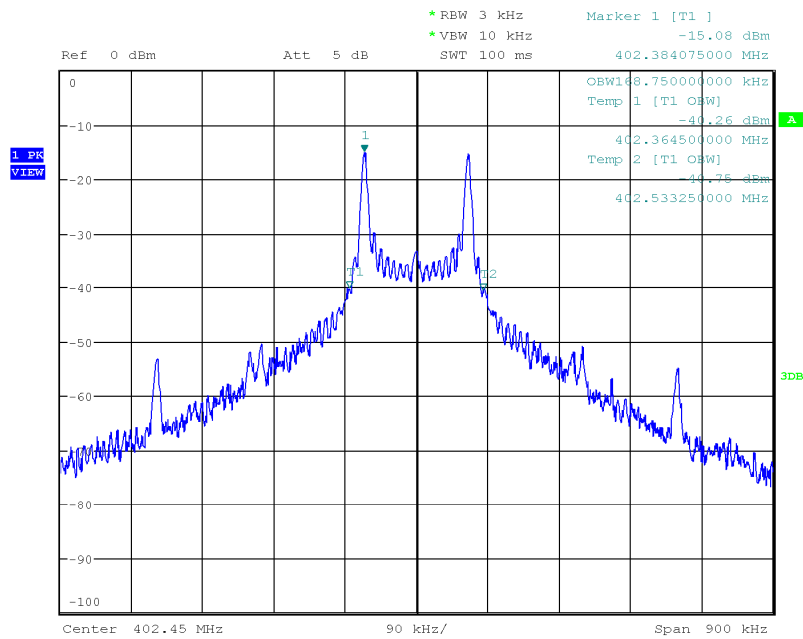

Date: 24.SEP.2019 15:45:55

Occupied Bandwidth RSS-243

Project Number: G0M-1908-8377
 Applicant: BIOTRONIK SE & Co. KG
 Model Description: CardioMessenger Smart / Telemonitorig System
 Model: CardioMessenger Smart 4G
 Test Sample ID: 25555
 Reference Method: RSS-Gen Issue 4 6.6 (Occupied Bandwidth)
 Operational Mode: 2FSK, 8 kbps, Channel: 0, 403.65 MHz
 Operating Conditions: Tnom / Vnom
 Operator: Wilfried Treffke
 Test Site: Eurofins Product Service GmbH
 Test Date: 2019-09-24
 Occupied Bandwidth [kHz]: 168.525

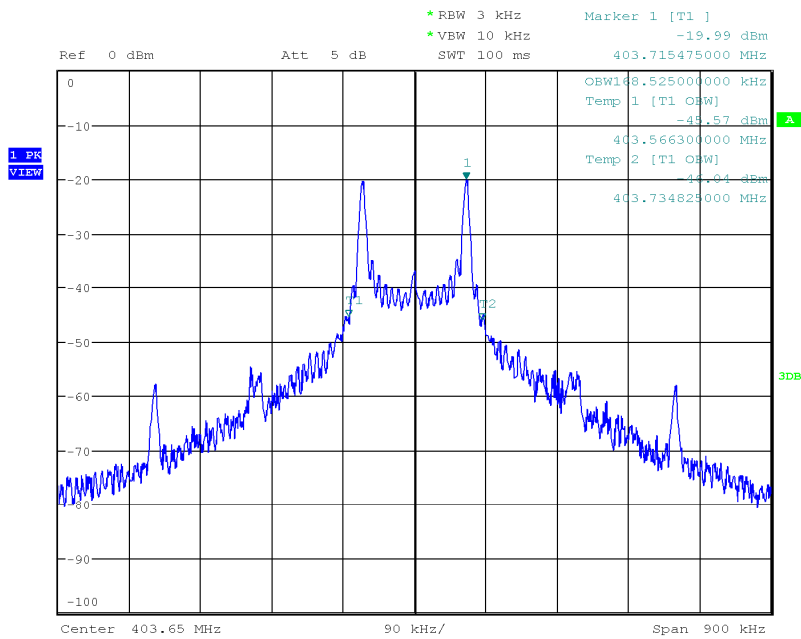

Date: 24.SEP.2019 15:48:53

Occupied Bandwidth RSS-243

Project Number: G0M-1908-8377
 Applicant: BIOTRONIK SE & Co. KG
 Model Description: CardioMessenger Smart / Telemonitorig System
 Model: CardioMessenger Smart 4G
 Test Sample ID: 25555
 Reference Method: RSS-Gen Issue 4 6.6 (Occupied Bandwidth)
 Operational Mode: 2FSK, 8 kbps, Channel: 7, 404.85 MHz
 Operating Conditions: Tnom / Vnom
 Operator: Wilfried Treffke
 Test Site: Eurofins Product Service GmbH
 Test Date: 2019-09-24
 Occupied Bandwidth [kHz]: 167.625

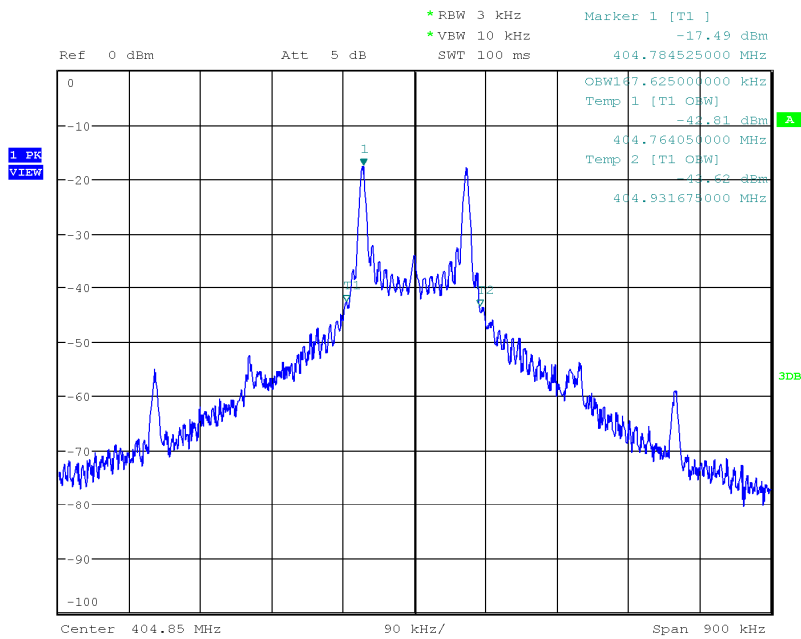

Date: 24.SEP.2019 15:50:25

Occupied Bandwidth RSS-243

Project Number: G0M-1908-8377
 Applicant: BIOTRONIK SE & Co. KG
 Model Description: CardioMessenger Smart / Telemonitorig System
 Model: CardioMessenger Smart 4G
 Test Sample ID: 25555
 Reference Method: RSS-Gen Issue 4 6.6 (Occupied Bandwidth)
 Operational Mode: 2FSK, 197kbps, Channel: 8, 402.45 MHz
 Operating Conditions: Tnom / Vnom
 Operator: Wilfried Treffke
 Test Site: Eurofins Product Service GmbH
 Test Date: 2019-09-24
 Occupied Bandwidth [kHz]: 233.550

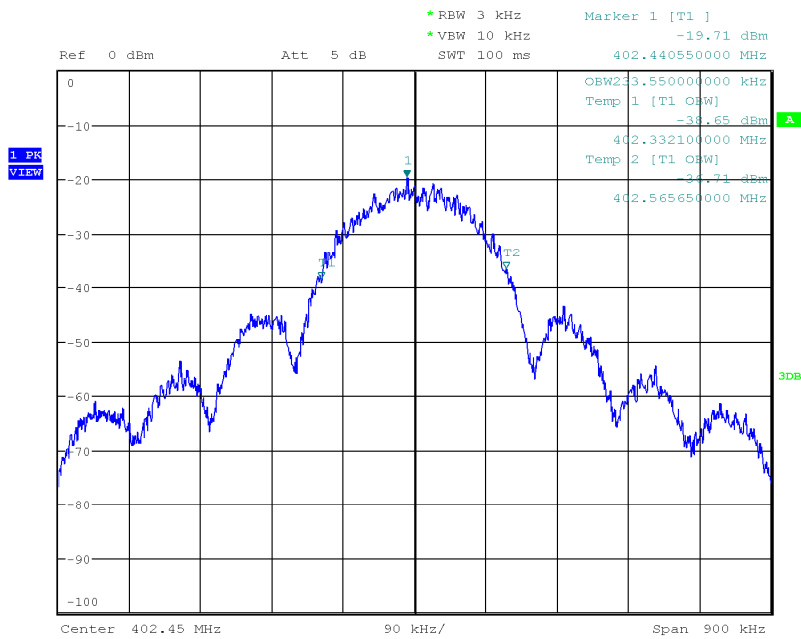

Date: 24.SEP.2019 16:09:48

Occupied Bandwidth RSS-243

Project Number: G0M-1908-8377
 Applicant: BIOTRONIK SE & Co. KG
 Model Description: CardioMessenger Smart / Telemonitorig System
 Model: CardioMessenger Smart 4G
 Test Sample ID: 25555
 Reference Method: RSS-Gen Issue 4 6.6 (Occupied Bandwidth)
 Operational Mode: 2FSK, 197kbps, Channel: 0, 403.65 MHz
 Operating Conditions: Tnom / Vnom
 Operator: Wilfried Treffke
 Test Site: Eurofins Product Service GmbH
 Test Date: 2019-09-24
 Occupied Bandwidth [kHz]: 233.325

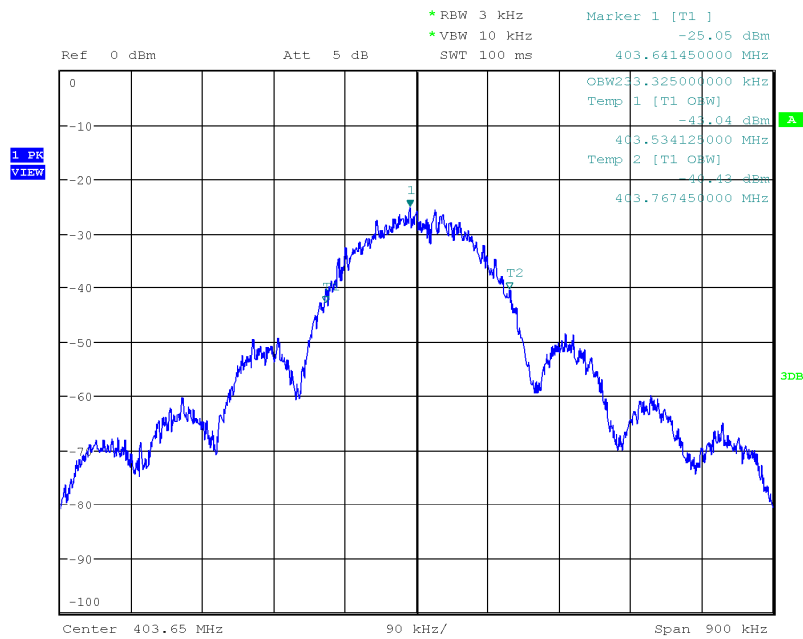

Date: 24.SEP.2019 16:10:49

Occupied Bandwidth RSS-243

Project Number: G0M-1908-8377
 Applicant: BIOTRONIK SE & Co. KG
 Model Description: CardioMessenger Smart / Telemonitorig System
 Model: CardioMessenger Smart 4G
 Test Sample ID: 25555
 Reference Method: RSS-Gen Issue 4 6.6 (Occupied Bandwidth)
 Operational Mode: 2FSK, 197kbps, Channel: 7, 404.85 MHz
 Operating Conditions: Tnom / Vnom
 Operator: Wilfried Treffke
 Test Site: Eurofins Product Service GmbH
 Test Date: 2019-09-24
 Occupied Bandwidth [kHz]: 234.450

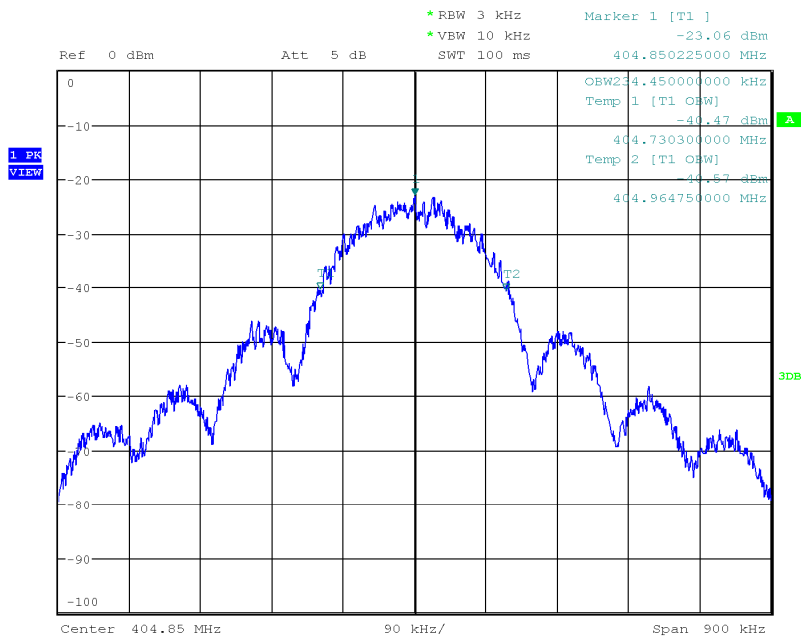

Date: 24.SEP.2019 16:12:13

3.2 Test Conditions and Results - Emission bandwidth

3.2.1 Information

Test Information	
Reference	FCC 95.2573(a) ISED RSS-243 3.6
Measurement Method	ANSI C63.10 6.9.2 ETSI EN 301 839 5.3.2
Operator	Wilfried Treffke
Date	2019-09-24

3.2.2 Limits

Limits
≤ 300 kHz

3.2.3 Setup

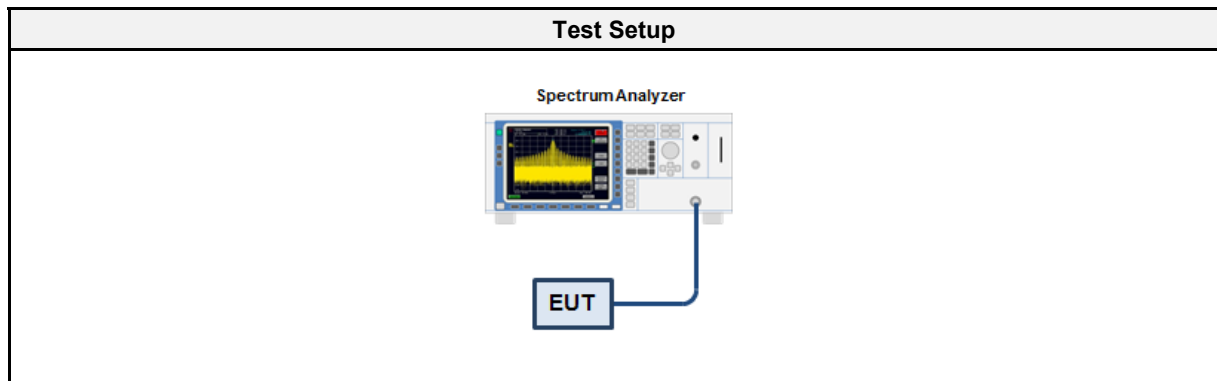

3.2.4 Equipment

Test Equipment					
Description	Manufacturer	Model	Identifier	Cal. Date	Cal. Due
Spectrum Analyzer	R&S	FSU 26	EF01407	2019-07	2020-07

3.2.5 Procedure

Test Procedure
<ol style="list-style-type: none"> 1. EUT set to test mode 2. Span set to at least twice the emission spectrum 3. Detector set to peak and max hold 4. Envelope peak value of emission spectrum is selected 5. Marker on envelope of spectrum is set to level of -20 dB to the left of the peak 6. Marker on envelope of spectrum is set to level of -20 dB to the right of the peak 7. 20dB Bandwidth is determined by marker frequency separation

3.2.6 Results

Test Results		
Mode	Channel [MHz]	Bandwidth [kHz]
Transmit	402.45	252.450
Transmit	403.65	249.975
Transmit	404.85	251.775

20 dB Bandwidth

Project Number: G0M-1908-8377
 Applicant: BIOTRONIK SE & Co. KG
 Model Description: CardioMessenger Smart / Telemonitorig System
 Model: CardioMessenger Smart 4G
 Test Sample ID: 25555
 Reference Standards: FCC 95.627
 Reference Method: 47 CFR § 95.627(a)(6)(i)
 Operational Mode: 2FSK, 197kbps, Channel: 8, 402.45 MHz
 Operating Conditions: Tnom/Vnom
 Operator: Wilfried Treffke
 Test Site: Eurofins Product Service GmbH
 Test Date: 2019-09-24
 Lower Frequency [MHz]: 402.324
 Upper Frequency [MHz]: 402.576
 20 dB Bandwidth [kHz]: 252.450

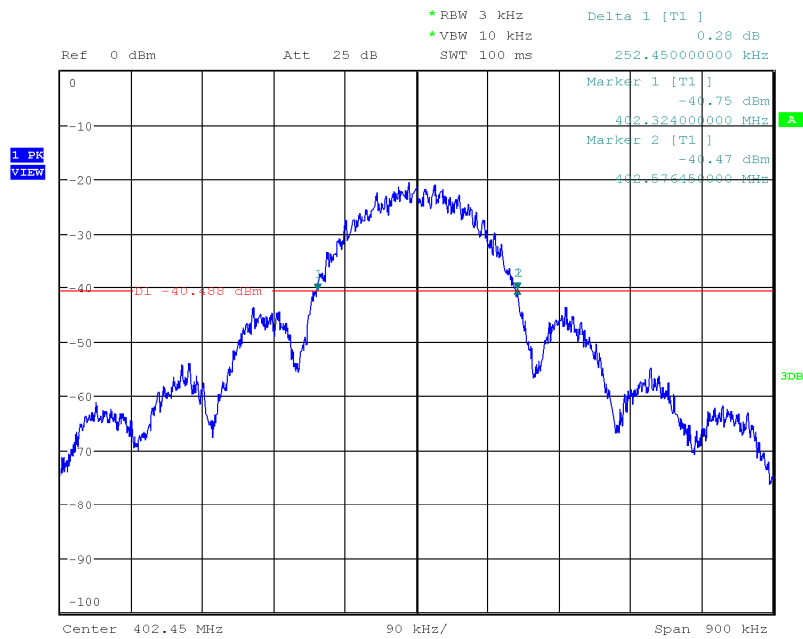

Date: 24.SEP.2019 16:28:56

20 dB Bandwidth

Project Number: G0M-1908-8377
 Applicant: BIOTRONIK SE & Co. KG
 Model Description: CardioMessenger Smart / Telemonitorig System
 Model: CardioMessenger Smart 4G
 Test Sample ID: 25555
 Reference Standards: FCC 95.627
 Reference Method: 47 CFR § 95.627(a)(6)(i)
 Operational Mode: 2FSK, 197kbps, Channel: 0, 403.65 MHz
 Operating Conditions: Tnom/Vnom
 Operator: Wilfried Treffke
 Test Site: Eurofins Product Service GmbH
 Test Date: 2019-09-24
 Lower Frequency [MHz]: 403.525
 Upper Frequency [MHz]: 403.775
 20 dB Bandwidth [kHz]: 249.975

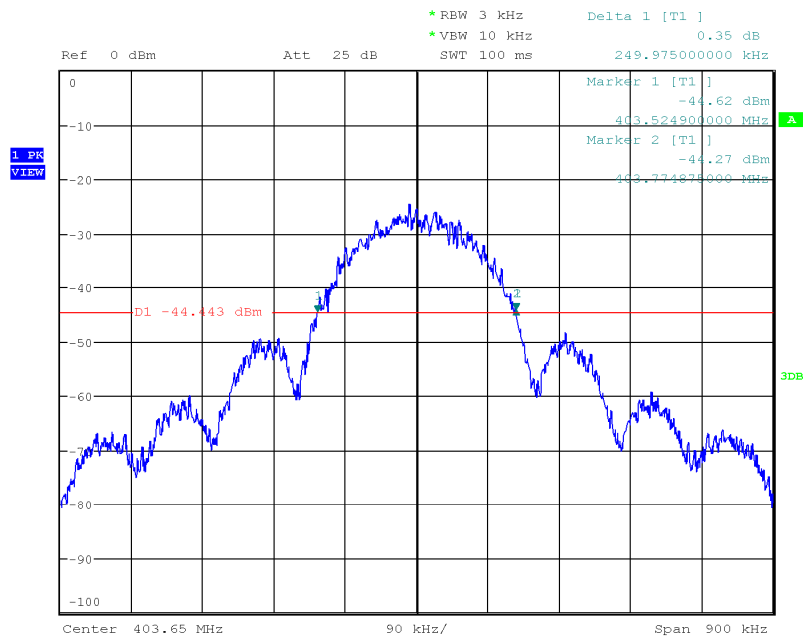

Date: 24.SEP.2019 16:30:11

20 dB Bandwidth

Project Number: G0M-1908-8377
Applicant: BIOTRONIK SE & Co. KG
Model Description: CardioMessenger Smart / Telemonitorig System
Model: CardioMessenger Smart 4G
Test Sample ID: 25555
Reference Standards: FCC 95.627
Reference Method: 47 CFR § 95.627(a)(6)(i)
Operational Mode: 2FSK, 197kbps, Channel: 7, 404.85 MHz
Operating Conditions: Tnom/Vnom
Operator: Wilfried Treffke
Test Site: Eurofins Product Service GmbH
Test Date: 2019-09-24
Lower Frequency [MHz]: 404.724
Upper Frequency [MHz]: 404.976
20 dB Bandwidth [kHz]: 251.775

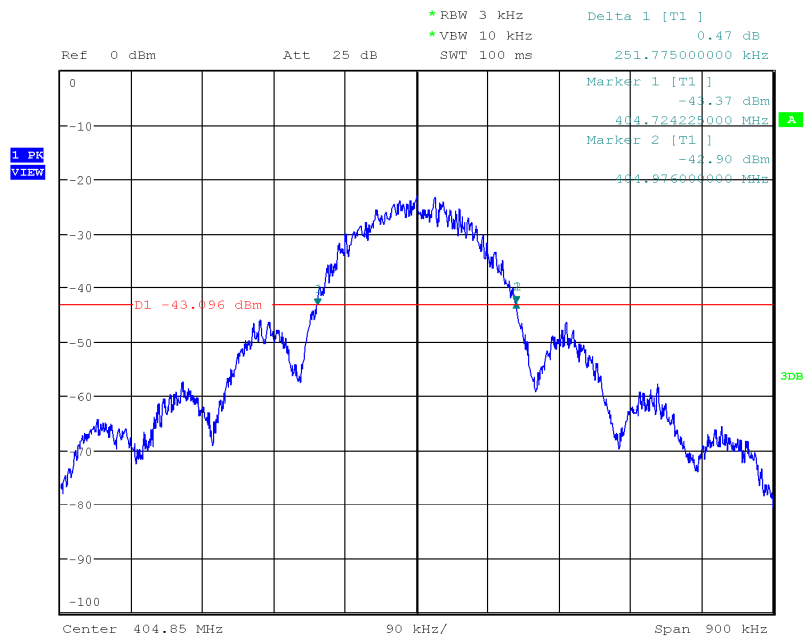

Date: 24.SEP.2019 16:32:52

3.3 Test Conditions and Results - Frequency stability

3.3.1 Information

Test Information	
Reference	FCC 95.2565 ISED RSS-243 3.3, 5.3
Measurement Method	ETSI EN 301 839 5.3.1
Operator	Wilfried Treffke
Date	2019-09-24

3.3.2 Limits

Limits
$\leq \pm 100$ ppm

3.3.3 Setup

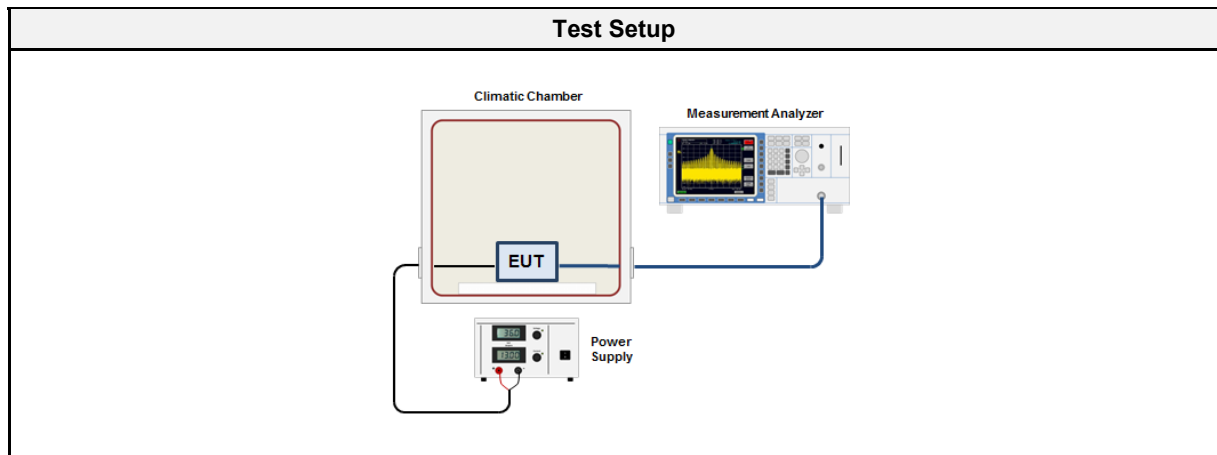

3.3.4 Equipment

Test Equipment					
Description	Manufacturer	Model	Identifier	Cal. Date	Cal. Due
Spectrum Analyzer	R&S	FSU 26	EF01407	2019-07	2020-07

3.3.5 Procedure

Test Procedure
<ol style="list-style-type: none"> 1. EUT set to test mode with supply voltage and temperature set to nominal conditions 2. EUT transmits without modulation 3. Detector set to peak and max hold 4. Peak of emission is measured using a frequency counter 5. The frequency error is determined as the deviation of the emission frequency from the nominal frequency stated by the customer.

3.3.6 Results

Test Results				
Channel [MHz]	Temperature [°C]	Supply voltage [VDC]	Frequency [MHz]	Drift [ppm]
402.45	-20	3.70	402.449425	-01.43
402.45	-10	3.70	402.450850	02.11
402.45	0	3.70	402.451342	03.33
402.45	10	3.70	402.451233	03.06
402.45	20	3.70	402.450515	01.28
402.45	30	3.70	402.449576	-01.05
402.45	40	3.70	402.448523	-03.67
402.45	50	3.70	402.447807	-05.45
402.45	55	3.70	402.447589	-05.99
404.85	-20	3.70	404.849596	-01.00
404.85	-10	3.70	404.851046	02.58
404.85	0	3.70	404.851534	03.79
404.85	10	3.70	404.851381	03.41
404.85	20	3.70	404.850689	01.70
404.85	30	3.70	404.849596	-01.00
404.85	40	3.70	404.851046	02.58
404.85	50	3.70	404.851534	03.79
404.85	55	3.70	404.851381	03.41

3.4 Test Conditions and Results - Transmitter output power

3.4.1 Information

Test Information	
Reference	FCC 95.2567(a), 95.2569 ISED RSS-243 5.4
Measurement Method	EN 301 839 5.3.3
Operator	Wilfried Treffke
Date	2019-09-23

3.4.2 Limits

Limits
$\leq 25 \mu\text{W}$ (-16 dBm) e.i.r.p.

3.4.3 Setup

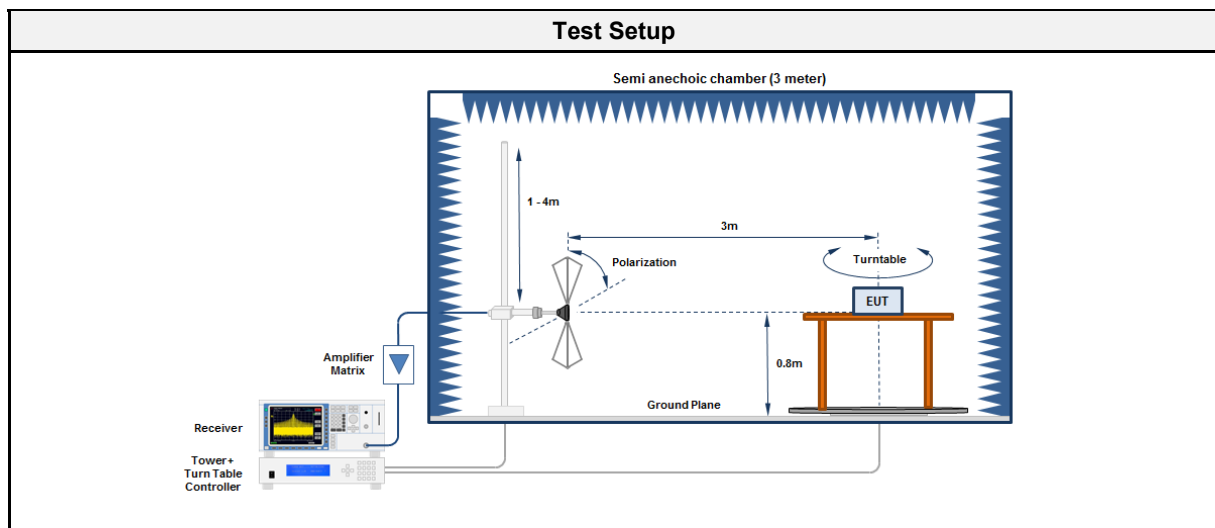

3.4.4 Equipment

Test Equipment					
Description	Manufacturer	Model	Identifier	Cal. Date	Cal. Due
Anechoic Chamber	Frankonia	AC1	EF00062	2018-07	2021-07
Spectrum Analyzer	R&S	FSU 26	EF01407	2019-07	2020-07
Antenna	R&S	HL 223	EF00187	2019-05	2022-05

3.4.5 Procedure

Test Procedure
<ol style="list-style-type: none"> 1. EUT set to test frequency with modulation 2. Measurement polarization is set to vertical 3. Span is set according to measurement range and detector is set to peak and max hold 4. Resolution bandwidth is set to be at least twice the emission bandwidth 5. During the sweep the EUT is rotated to obtain maximum emission level 6. Measurement is repeated with horizontal measurement polarization

3.4.6 Results

Test Results				
Channel [MHz]	Emission Level [dBm e.i.r.p.]	Detector	Limit [dBm e.i.r.p.]	Margin [dB]
402.45	-16.0	pk	-16	0.0
403.65	-16.7	pk	-16	-00.70
404.85	-16.1	pk	-16	-00.10

3.5 Test Conditions and Results - Band-edge and In-band Emissions

3.5.1 Information

Test Information	
Reference	FCC 95.2579 ISED RSS-243 3.4, 5.5
Measurement Method	ANSI C63.10 6.10
Operator	Wilfried Treffke
Date	2019-09-23

3.5.2 Limits

Limits FCC	
Frequency range	Limit
402 MHz – 250 kHz $\leq f \leq$ 402 MHz	20 dB below maximum permitted output power
402 MHz < f < 150 kHz - f _c	20 dB below transmitter output power
150 kHz + f _c < f < 405 MHz	20 dB below transmitter output power
405 MHz $\leq f \leq$ 405 MHz + 250 kHz	20 dB below maximum permitted output power
Limits ISED	
Frequency range	Limit
402 MHz – 250 kHz < f < 150 kHz-f _c	20 dB below maximum permitted output power
150 kHz+f _c < f < 405 MHz + 250 kHz	20 dB below maximum permitted output power

The FCC limits are more stringent than the ISED limits, that is why the FCC limits are used to fulfil the band-edge emission requirements

3.5.3 Setup

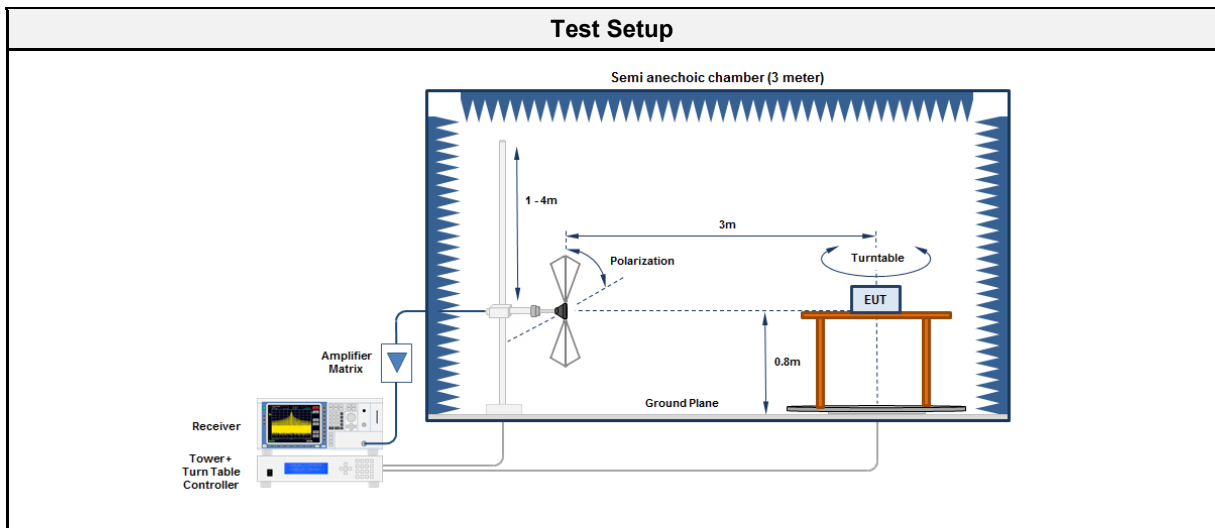

3.5.4 Equipment

Test Equipment					
Description	Manufacturer	Model	Identifier	Cal. Date	Cal. Due
Anechoic Chamber	Frankonia	AC1	EF00062	2018-07	2021-07
Spectrum Analyzer	R&S	FSU 26	EF01407	2019-07	2020-07
Antenna	R&S	HL 223	EF00187	2019-05	2022-05

3.5.5 Procedure

Test Procedure
1. EUT set to test frequency with modulation
2. Measurement polarization is set to vertical
3. Span it set according to measurement range
4. Resolution bandwidth is set to 1% of the emission bandwidth and detector is set to peak
5. During the sweep the EUT is rotated to obtain maximum emission level
6. Measurement is repeated with horizontal measurement polarization

3.5.6 Results

Test Results					
Channel [MHz]	Emission [MHz]	Level [dB μ V/m]	Pol.	Limit [dB μ V/m]	Margin [dB]
402.45	401.99	27.10	hor	59.40	-32.30
402.45	402.25	31.94	ver	54.00	-22.06
402.45	402.27	44.91	hor	54.00	-09.09
402.45	402.60	41.76	hor	54.00	-12.24
402.45	402.65	34.34	ver	54.00	-19.66
404.85	404.66	32.17	ver	55.00	-22.83
404.85	404.70	39.40	hor	55.00	-15.60
404.85	405.00	43.33	hor	55.00	-11.67
404.85	405.00	32.08	ver	55.00	-22.92
404.85	405.00	41.98	hor	59.40	-17.42
404.85	405.01	32.78	ver	59.40	-26.62

3.6 Test Conditions and Results - Transmitter unwanted emissions

3.6.1 Information

Test Information	
Reference	FCC 95.2579 ISED RSS-243 3.4, 5.5
Measurement Method	ANSI C63.10 6.10
Operator	Wilfried Treffke
Date	2019-09-23

3.6.2 Limits

Limits				
Frequency range [MHz]	Detector	Limit [$\mu\text{V}/\text{m}$]	Limit [$\text{dB}\mu\text{V}/\text{m}$]	Limit Distance [m]
30 – 88	Quasi-Peak	100	40	3
88 – 216	Quasi-Peak	150	43.5	3
216 – 960	Quasi-Peak	200	46	3
960 – 1000	Quasi-Peak	500	54	3
> 1000	Average	500	54	3

3.6.3 Setup

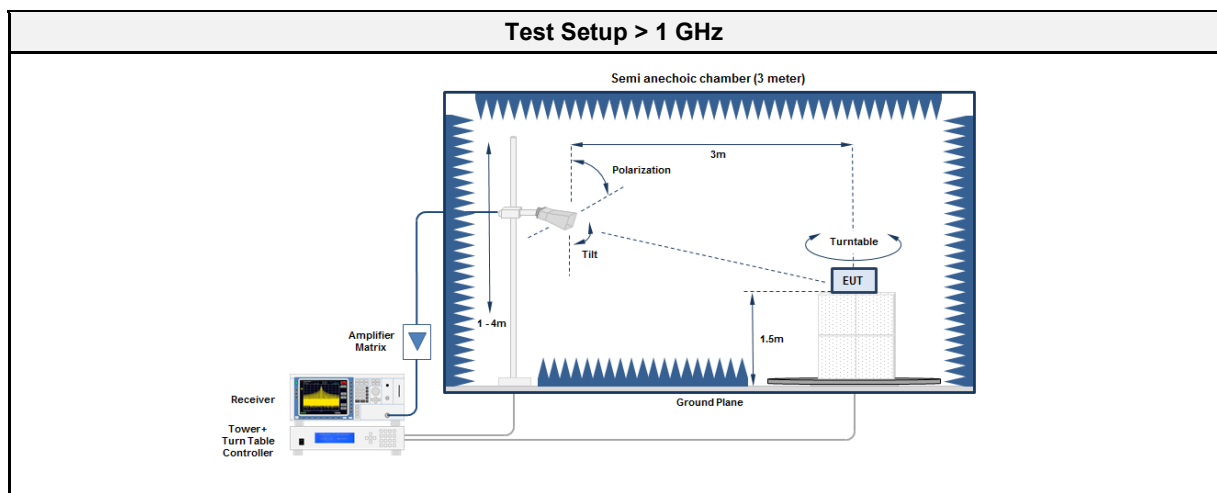
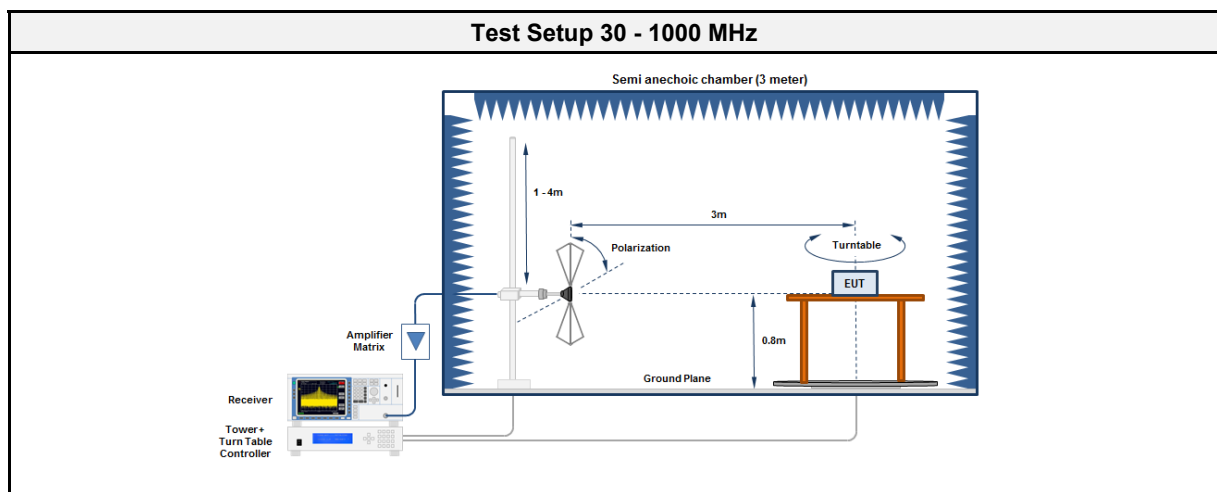

3.6.4 Equipment

Test Equipment 30 - 1000 MHz					
Description	Manufacturer	Model	Identifier	Cal. Date	Cal. Due
Anechoic Chamber	Frankonia	AC1	EF00062	2018-07	2021-07
Measurement Receiver	Agilent	N9038A-526/WXP	EF01070	2019-09	2020-09
Antenna	R&S	HK 116	EF00030	2019-04	2022-04
Antenna	R&S	HL 223	EF00212	2019-05	2020-05

Test Equipment > 1 GHz					
Description	Manufacturer	Model	Identifier	Cal. Date	Cal. Due
Anechoic Chamber	Frankonia	AC1	EF00062	2018-07	2021-07
Measurement Receiver	Agilent	N9038A-526/WXP	EF01070	2019-09	2020-09
Antenna	Schwarzbeck	BBHA 9120D	EF01153	2019-10	2020-10
Antenna	Amplifier Research	AT4560	EF00302	2019-05	2020-05

3.6.5 Procedure

Test Procedure
<ol style="list-style-type: none"> 1. EUT set to test mode 2. Span it set according to measurement range 3. Resolution bandwidth below 1 GHz is set according to CISPR 16 with peak/quasi-peak detector and RBW of 1 MHz with peak/average detector is used above 1 GHz 4. Markers are set to peak emission levels within restricted bands

3.6.6 Results

Test Results							
Channel [MHz]	Emission [MHz]	Level [dB μ V/m]	Det.	Pol.	Limit [dB μ V/m]	Limit dist. [m]	Margin [dB]
402.45	401.75	30.68	pk	hor	46.00	3	-15.32
402.45	405.25	31.02	pk	hor	46.00	3	-14.98
402.45	805.563	40.04	pk	hor	46.00	3	-05.96
404.85	401.103	23.18	pk	ver	46.00	3	-22.82
404.85	401.427	29.72	pk	hor	46.00	3	-16.28
404.85	405.25	39.69	pk	hor	46.00	3	-06.31
404.85	405.25	34.18	pk	ver	46.00	3	-11.82
404.85	809.375	38.07	pk	hor	46.00	3	-07.93
404.85	885.625	34.67	pk	ver	46.00	3	-11.33

3.7 Test Conditions and Results - Receiver spurious emissions

3.7.1 Information

Test Information	
Reference	ISED RSS-243 3.5, 5.6 ISED RSS-Gen 7.3
Measurement Method	ANSI C63.10 6.10
Operator	Wilfried Treffke
Date	2019-09-23

3.7.2 Limits

Limits				
Frequency range [MHz]	Detector	Limit [$\mu\text{V}/\text{m}$]	Limit [$\text{dB}\mu\text{V}/\text{m}$]	Limit Distance [m]
30 – 88	Quasi-Peak	100	40	3
88 – 216	Quasi-Peak	150	43.5	3
216 – 960	Quasi-Peak	200	46	3
960 – 1000	Quasi-Peak	500	54	3
> 1000	Average	500	54	3

3.7.3 Setup

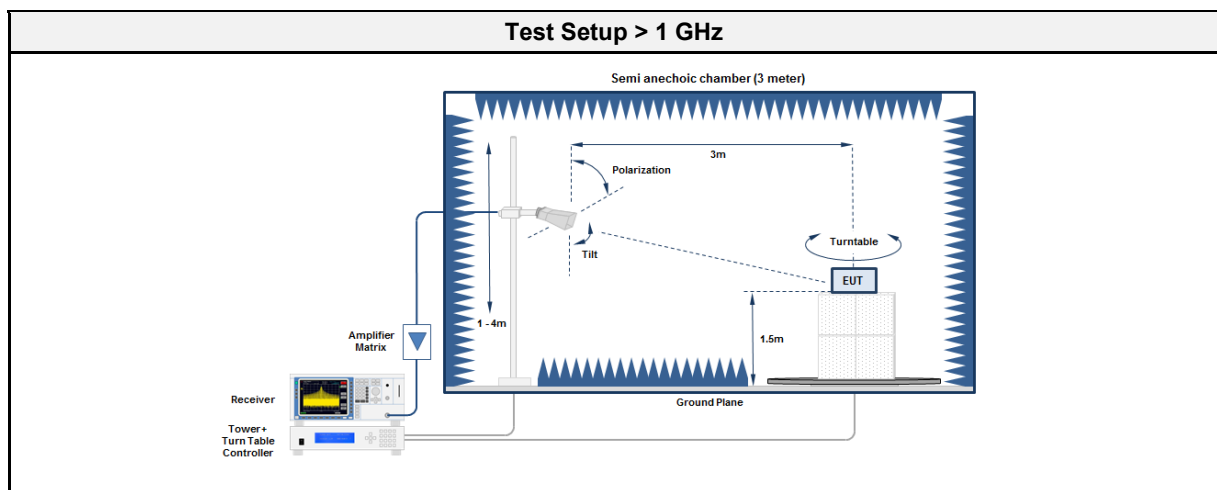
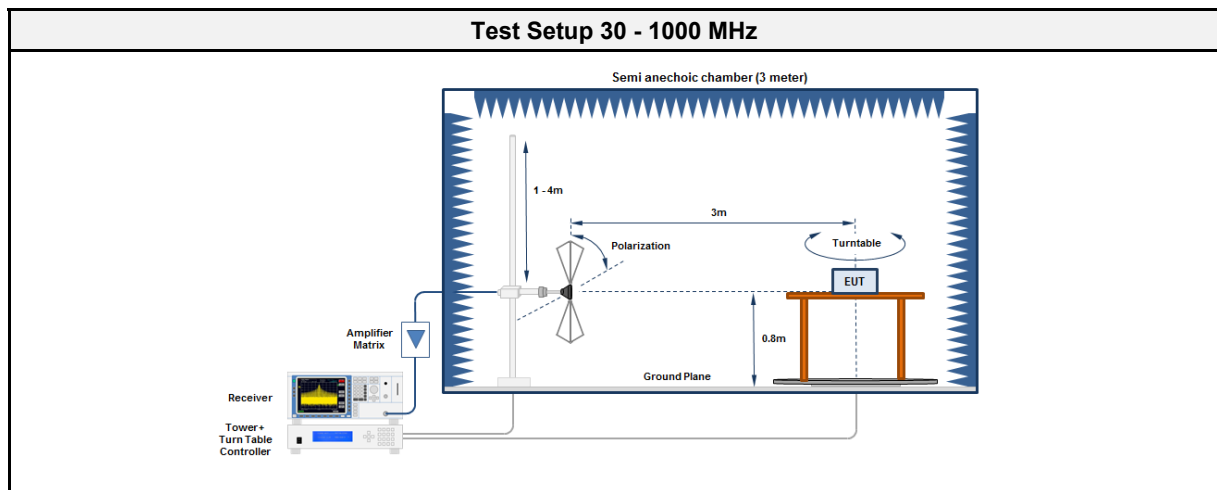

3.7.4 Equipment

Test Equipment 30 - 1000 MHz					
Description	Manufacturer	Model	Identifier	Cal. Date	Cal. Due
Anechoic Chamber	Frankonia	AC1	EF00062	2018-07	2021-07
Measurement Receiver	Agilent	N9038A-526/WXP	EF01070	2019-09	2020-09
Antenna	R&S	HK 116	EF00030	2019-04	2022-04
Antenna	R&S	HL 223	EF00212	2019-05	2020-05

Test Equipment > 1 GHz					
Description	Manufacturer	Model	Identifier	Cal. Date	Cal. Due
Anechoic Chamber	Frankonia	AC1	EF00062	2018-07	2021-07
Measurement Receiver	Agilent	N9038A-526/WXP	EF01070	2019-09	2020-09
Antenna	Schwarzbeck	BBHA 9120D	EF01153	2019-10	2020-10

3.7.5 Procedure

Test Procedure
<ol style="list-style-type: none"> 1. EUT set to receive mode 2. Span it set according to measurement range 3. Resolution bandwidth below 1 GHz is set according to CISPR 16 with peak/quasi-peak detector and RBW of 1 MHz with peak/average detector is used above 1 GHz 4. Markers are set to peak emission levels

3.7.6 Results

Test Results						
Channel [MHz]	Emission [MHz]	Emission Level [dB μ V/m]	Det.	Pol.	Limit [dB μ V/m]	Margin [dB]
403.65	199.183	31.71	pk	hor	43.50	-11.79
403.65	891.026	21.17	pk	hor	46.00	-24.83
403.65	907.692	20.81	pk	ver	46.00	-25.19
403.65	3933	39.06	pk	ver	53.90	-14.84
403.65	3981	38.77	pk	hor	53.90	-15.13

3.8 Test Conditions and Results - AC power line conducted emissions

3.8.1 Information

Test Information	
Reference	FCC 15.207 ISED RSS-Gen 7.2, 8.8
Measurement Method	ANSI C63.10 6.2
Operator	Wilfried Treffke
Date	2019-09-24

3.8.2 Limits

Limits		
Frequency [MHz]	Quasi-Peak [dBμV]	Average [dBμV]
0.15 - 0.5	66 - 56*	56 - 46*
0.5 - 5	56	46
5 - 30	60	50

* Limit decreases linearly with the logarithm of the frequency

3.8.3 Setup

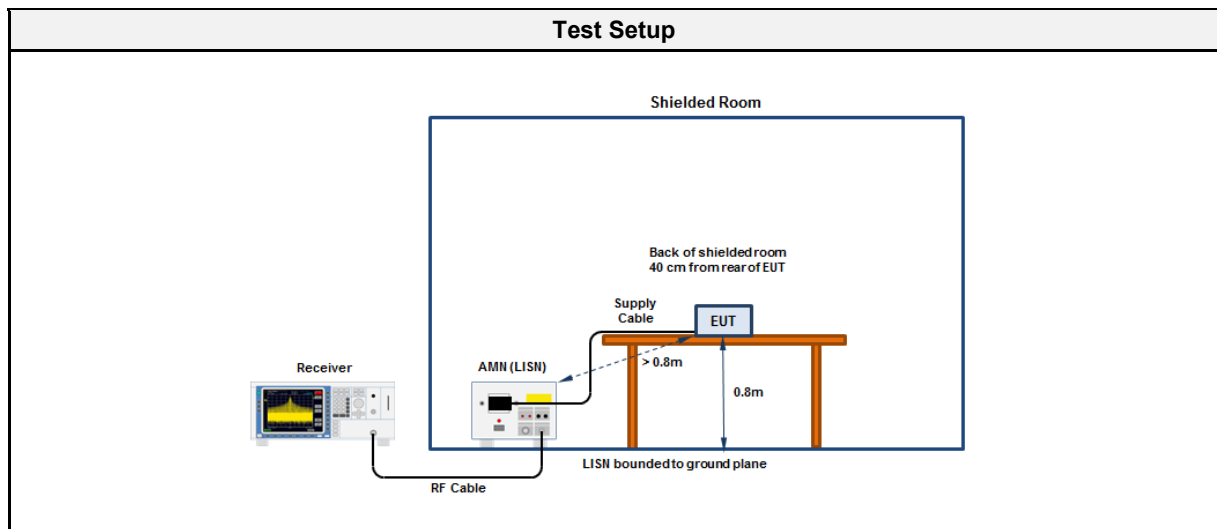

3.8.4 Equipment

Test Equipment					
Description	Manufacturer	Model	Identifier	Cal. Date	Cal. Due
EMI Receiver	R&S	ESU 26	EF00241	2019-07	2021-07
LISN	Schwarzbeck	NSLK 8128	EF00975	2019-07	2021-07

Conducted emissions according to FCC part 15 C

Project number: G0M-1908-8377

Applicant: BIOTRONIK SE & Co. KG
 EUT Name: CardioMessenger Smart / Telemonitorig System
 Model: CardioMessenger Smart 4G
 Test Site: Eurofins Product Service GmbH
 Operator: Mr. Treffke
 Test Conditions: Tnom: 20°C, Unom: 120 V 60 Hz
 LISN: Schwarzbeck NSLK 8128 (L)
 Mode: Mode 1 Configuration 1
 Test Date: 2019-09-24
 Note: MICS, Tx 403.65 MHz

Index 4

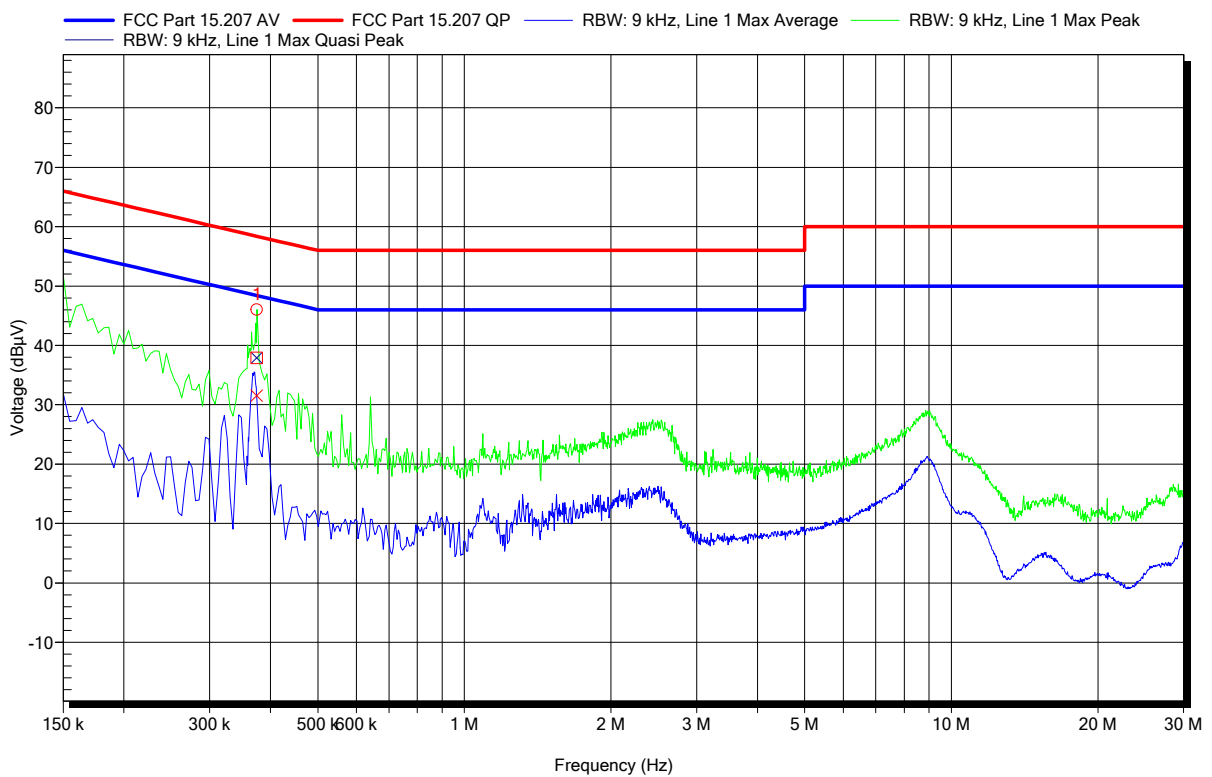

Peak Number	Frequency	Quasi-Peak	Quasi-Peak Limit	Quasi-Peak Difference	Quasi-Peak Status
1	374.55 kHz	37.9 dBµV	58.4 dBµV	-20.5 dB	Pass
Peak Number	Frequency	Average	Average Limit	Average Difference	Average Status
1	374.55 kHz	31.5 dBµV	48.4 dBµV	-16.9 dB	Pass

Conducted emissions according to FCC part 15 C

Project number: G0M-1908-8377

Applicant: BIOTRONIK SE & Co. KG
 EUT Name: CardioMessenger Smart / Telemonitorig System
 Model: CardioMessenger Smart 4G
 Test Site: Eurofins Product Service GmbH
 Operator: Mr. Treffke
 Test Conditions: Tnom: 20°C, Unom: 120 V 60 Hz
 LISN: Schwarzbeck NSLK 8128 (N)
 Mode: Mode 1 Configuration 1
 Test Date: 2019-09-24
 Note: MICS, Tx 403.65 MHz

Index 3

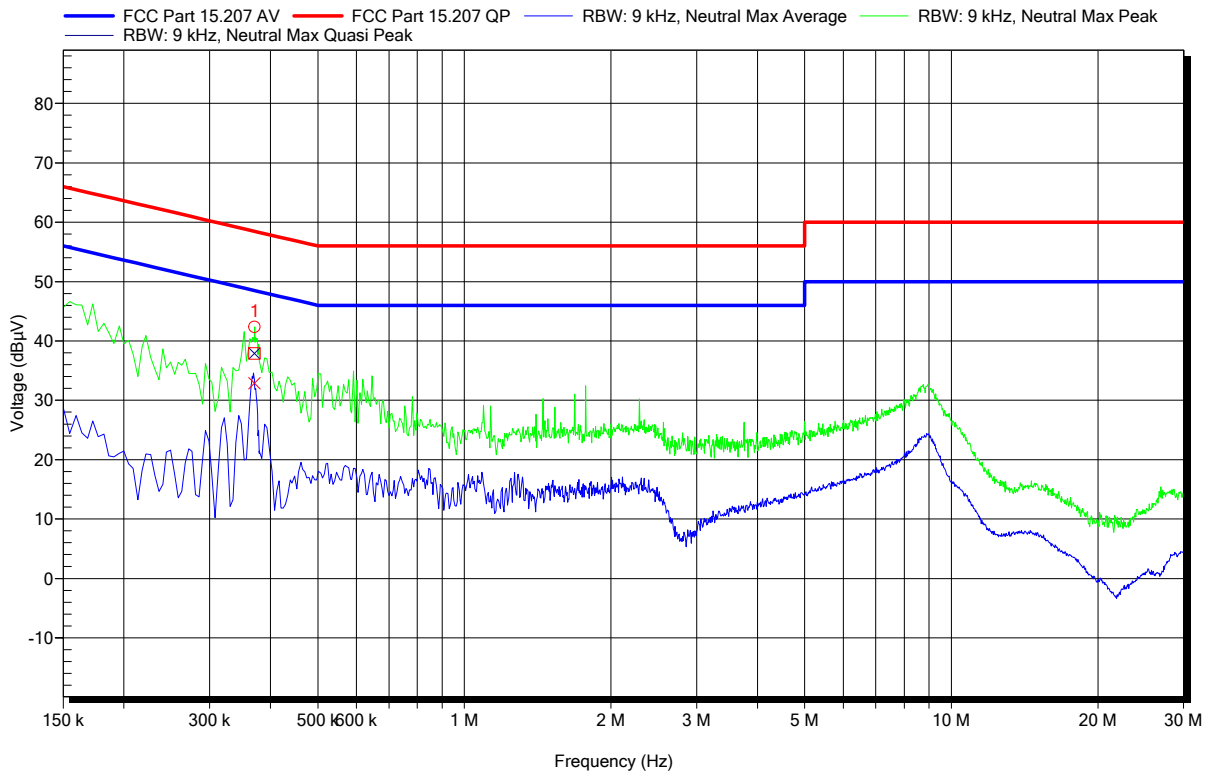

Peak Number	Frequency	Quasi-Peak	Quasi-Peak Limit	Quasi-Peak Difference	Quasi-Peak Status
1	370.95 kHz	37.9 dBµV	58.5 dBµV	-20.6 dB	Pass
Peak Number	Frequency	Average	Average Limit	Average Difference	Average Status
1	370.95 kHz	32.9 dBµV	48.5 dBµV	-15.6 dB	Pass

3.9 Test Conditions and Results - System threshold power levels

3.9.1 Information

Test Information	
Reference	FCC 95.2559(a)(3),(a)(4) ISED RSS-243 3.6, 5.7.1
Measurement Method	ETSI EN 301 839 5.3.7.1.3
Operator	Wilfried Treffke
Date	2019-09-24

3.9.2 Limits

Limits
$P_{TH} [dBm] = 10 \cdot \text{Log}_{10}(EB[Hz]) - 150 + G[dBi]$ <p> P_{TH} = LBT threshold level in dBm EB = Emission bandwidth in Hz G = Monitoring system antenna gain in dBi </p>
If an ULP-AMI device is used to select the frequency of operation for a MICS system, the above LBT threshold level requirement may be adjusted higher by 1 dB for every 1 dB the e.r.p. of the device performing the LBT and AFA function is below the maximum permitted level of -16 dBm e.r.p..

3.9.3 Procedure

Test Procedure
It is not necessary to measure the actual threshold power level of a MICS system; however, it shall be determined that the system uses the LIC selection process if no channel is available with an ambient power level at or below the calculated threshold power level.

3.9.4 Results

Test Results			
Emission bandwidth of companion device [Hz]	Antenna gain [dBi]	Calculated level [dBm]	Measured threshold level [dBm]
254.250	1.91	-94.0	-94
The EUT changed the channel from f_c (channel 0) to channel 1 at CW level of -94.0 dBm			

3.10 Test Conditions and Results - Monitoring system bandwidth

3.10.1 Information

Test Information	
Reference	FCC 95.2559(a)(1) ISED RSS-243 3.6, 5.7.2
Measurement Method	ETSI EN 301 839 5.3.7.1.4
Operator	Wilfried Treffke
Date	2019-09-24

3.10.2 Limits

Limits
≥ Emission bandwidth (equals to measured power level differences ≤ 20 dB)

3.10.3 Setup

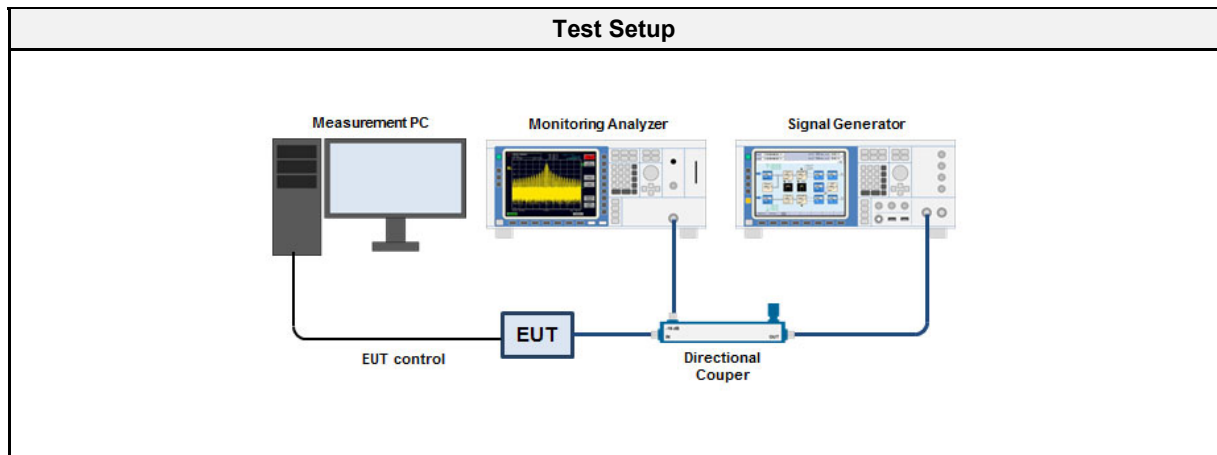

3.10.4 Equipment

Test Equipment - Radiated measurement					
Description	Manufacturer	Model	Identifier	Cal. Date	Cal. Due
Spectrum Analyzer	R&S	FSU 26	EF01407	2019-07	2020-07
Signal Generator	R&S	SMU200A	EF00004	2019-07	2020-07

3.10.5 Procedure

Test Procedure	
<p>1. By administration commands the following channel occupation is simulated to the device so that the EUT can only send on frequency f_c.</p>	
<p>2. A CW signal is generated by the signal generator on frequency f_c with a level sufficient to block transmission of the EUT on channel f_c. It is verified that the EUT stops transmission.</p> <p>3. A new communication session is established and the level of the signal generator is reduced until the EUT starts to transmit on channel f_c.</p> <p>4. Then the frequency of the generator is set to the measured lower edge frequency of the emission bandwidth and the level of the signal generator is increased until the EUT starts to transmit in the out-of-band region again. The signal level is recorded.</p> <p>5. The procedure is repeated at the upper edge frequency of the emission bandwidth measurement. The power level difference between the center and the edge frequency is recorded.</p>	

3.10.6 Results

Test Results					
Channel [MHz]	Center Interferer Level [dBm]	Edge \pm EBW/2 [kHz]	Edge Interferer Level [dBm]	Level Difference [dB]	Limit [dB]
403.65	403.521	-EBW/2	-88	2	≤ 20
403.65	403.775	+EBW/2	-83	7	≤ 20

3.11 Test Conditions and Results - Scan cycle time

3.11.1 Information

Test Information	
Reference	FCC 95.2559(a)(2) ISED RSS-243 3.6, 5.7.3
Measurement Method	ETSI EN 301 839 5.3.7.1.5
Operator	Wilfried Treffke
Date	2019-09-24

3.11.2 Limits

Limits
≤ 5 s

3.11.3 Setup

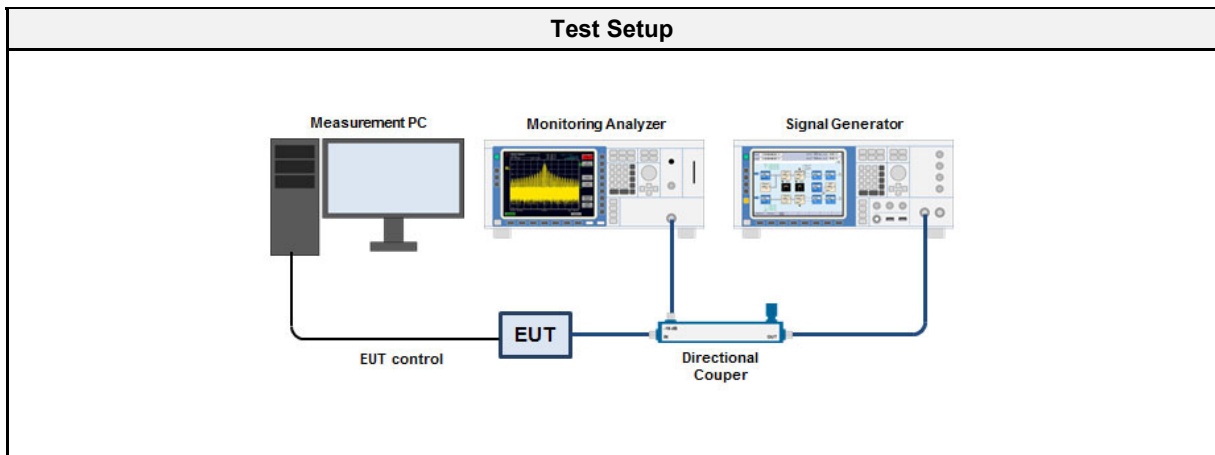

3.11.4 Equipment

Test Equipment - Radiated measurement					
Description	Manufacturer	Model	Identifier	Cal. Date	Cal. Due
Spectrum Analyzer	R&S	FSU 26	EF01407	2019-07	2020-07
Signal Generator	R&S	SMU200A	EF00004	2019-07	2020-07

3.11.5 Procedure

Test Procedure	
<p>1. By administration commands the following channel occupation is simulated to the device so that the EUT can only send on frequency f_c.</p>	
<p>2. A CW signal is generated by the signal generator on frequency f_c with a level 3 dB above the out-of-band region level to block transmission of the EUT on channel f_c. It is verified that the EUT does not transmit on f_c.</p> <p>3. The CW interferer is removed, a new communication session is established and the time until the EUT starts to transmit is measured.</p> <p>4. If the EUT does not transmit on f_c a 1 second delay is added between the removal of the interferer and the establishment of the communication session. The addition of delay is repeated until the EUT always starts transmission on f_c. The delay time measurement is repeated several times. At the end 1 second is subtracted from all delays measured.</p>	

3.11.6 Results

Test Results		
Channel [MHz]	Scan cycle time [s]	Limit [s]
403.65	4.6	≤ 5 s

Spectrum access protocol - System scan cycle time

Project Number: G0M-1908-8377
 Applicant: BIOTRONIK SE & Co. KG
 Model Description: CardioMessenger Smart / Telemonitorig System
 Model: CardioMessenger Smart 4G
 Test Sample ID: 25555
 Operator: W. Treffke
 Test Site: Eurofins Product Service GmbH
 Test Date: 2019-09-24
 Operating Conditions: Tnom/Vnom
 Mode: search mode
 Note 1: Limit:< 5 sec
 Note 2: Result: 4.6 s
 Note 3: Carrier changed from ch.1 to ch. 0

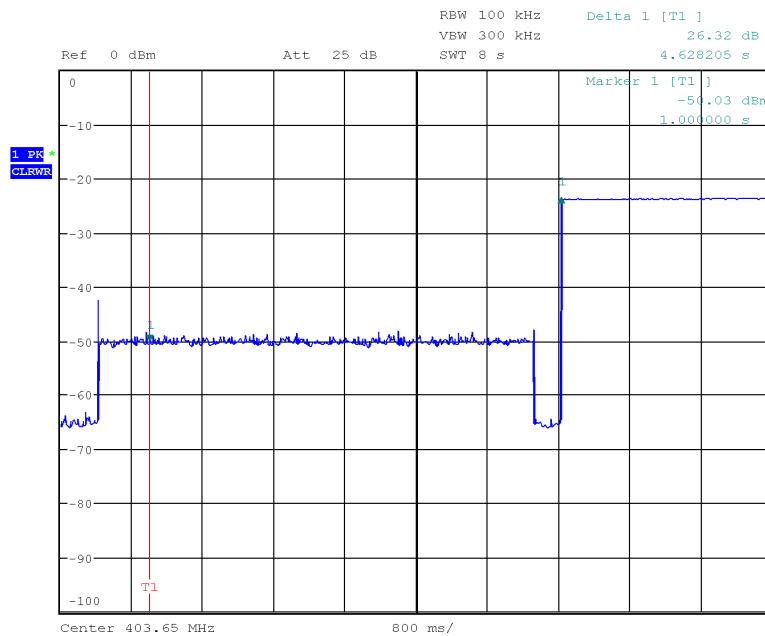

Date: 24.SEP.2019 13:51:00

3.12 Test Conditions and Results - Minimum channel monitoring period

3.12.1 Information

Test Information	
Reference	FCC 95.2559(a)(2) ISED RSS-243 3.6, 5.7.4
Measurement Method	ETSI EN 301 839 5.3.7.1.5
Operator	Wilfried Treffke
Date	2019-09-24

3.12.2 Limits

Limits
≥ 10 ms

3.12.3 Setup

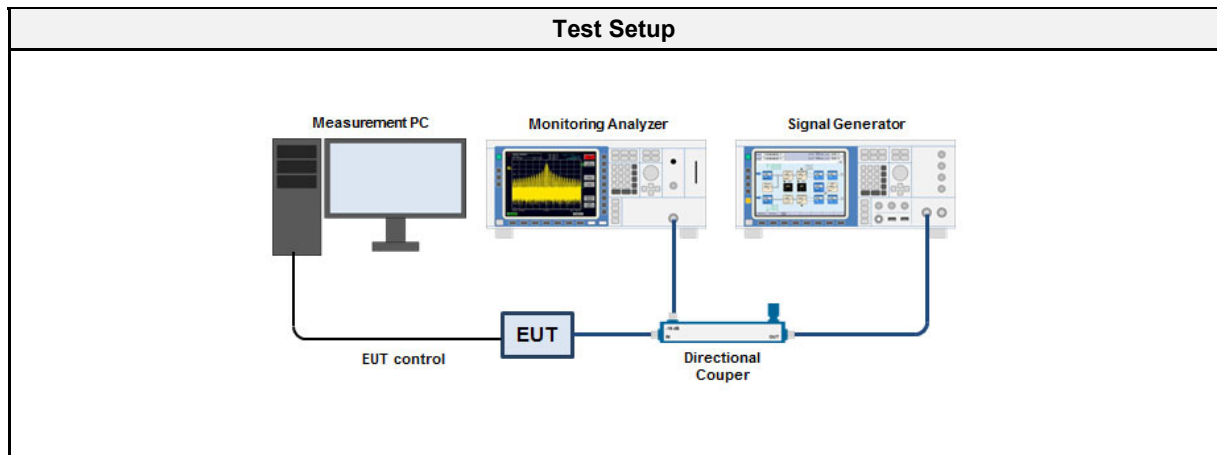

3.12.4 Equipment

Test Equipment - Radiated measurement					
Description	Manufacturer	Model	Identifier	Cal. Date	Cal. Due
Spectrum Analyzer	R&S	FSU 26	EF01407	2019-07	2020-07
Signal Generator	R&S	SMU200A	EF00004	2019-07	2020-07

3.12.5 Procedure

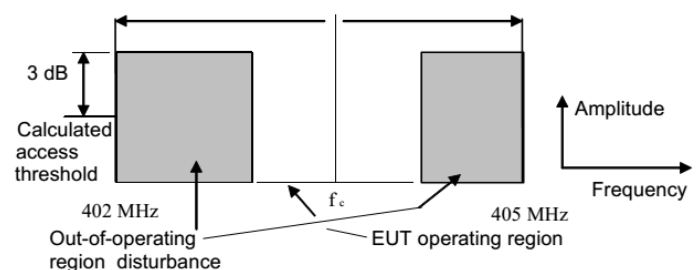
Test Procedure	
<p>1. By administration commands the following channel occupation is simulated to the device so that the EUT can only send on frequency f_c.</p>	
<p>2. A CW signal is generated by the signal generator on frequency f_c with a level equal to the out-of-band region level to block transmission of the EUT on channel f_c and the out-of-band interference is removed. It is verified that the EUT does not transmit on f_c.</p> <p>3. Then the out-of-band interference level is set to 3 dB higher and it is verified that the EUT transmits on f_c.</p> <p>4. The out-of-band interferers are pulsed with a pulse width of 0.1 ms and a repetition frequency of 100Hz. The EUT is placed in a state where it is seeking to initiate a communication session with the ULP-AMI companion device.</p> <p>5. The EUT shall not initiate a communication session on a channel different from f_c. This condition is checked more than 10 times.</p>	

3.12.6 Results

Test Results				
Channel [MHz]	Interferer Channel	Interferer level [dBm]	Carrier transmit on channel	Result
403.65	403.65	off	403.65	PASS
403.65	403.65	-88.0	403.05	PASS
<p>For practical reasons the test has been performed with a fixed interferer level in the out-of-band region and a pulsed interferer level on center channel. To make sure that the monitoring period requirement was met, it was verified that no communication on center channel had been initiated.</p>				

3.13 Test Conditions and Results - Channel access

3.13.1 Information

Test Information	
Reference	FCC 95.2559(a)(5) ISED RSS-243 3.6, 5.7.5
Measurement Method	EN 301 839 5.3.7.1.6
Operator	Wilfried Treffke
Date	2019-10-30

3.13.2 Limits

Limits
EUT has to select and transmit on least interfered channel (LIC)

3.13.3 Setup

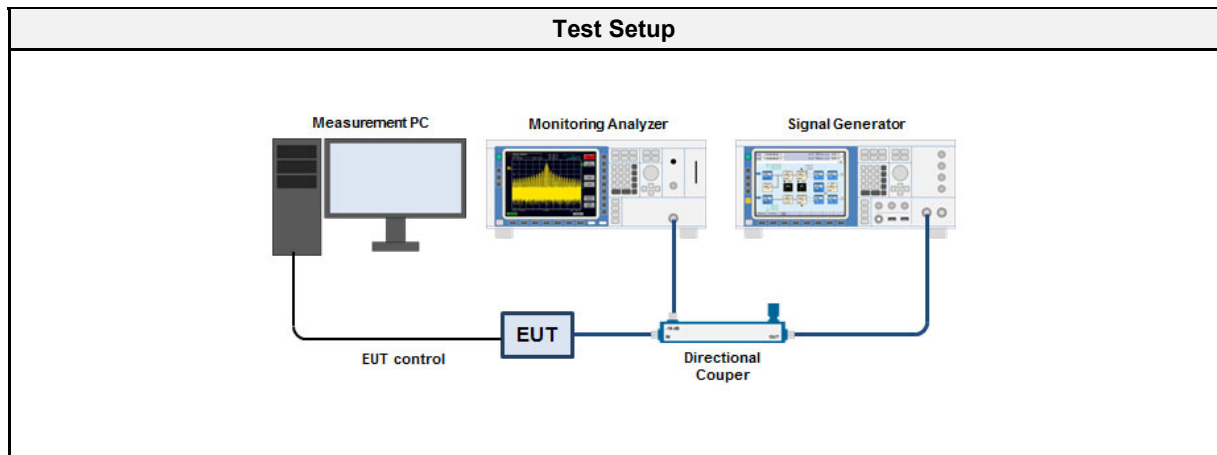

3.13.4 Equipment

Test Equipment - Radiated measurement					
Description	Manufacturer	Model	Identifier	Cal. Date	Cal. Due
Spectrum Analyzer	R&S	FSU 26	EF01407	2019-07	2020-07
Signal Generator	R&S	SMU200A	EF00004	2019-07	2020-07

3.13.5 Procedure

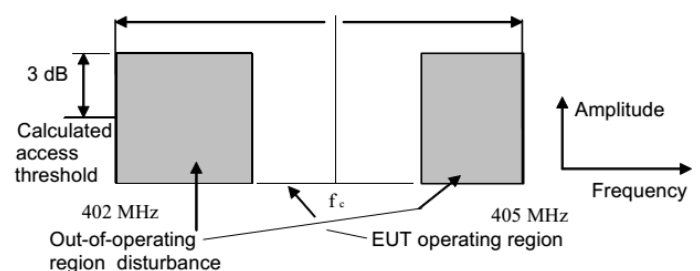
Test Procedure
<p>1. By administration commands the following channel occupation is simulated to the device so that the EUT can only send on frequency f_c.</p> <div style="text-align: center; margin: 10px 0;">  </div>
<p>2. A CW signal is generated by the signal generator on frequency f_c with a level 3 dB lower than the calculated LBT threshold level. It is determined that the EUT communicates on f_c.</p> <p>3. The CW interferer level is increased by 9dB and a new communication session is initiated. Now it is checked that the EUT communicates on the LIC center frequency.</p>

3.13.6 Results

Test Results						
Step	Channel [MHz]	LIC channel	Frequency [MHz]	Interferer level channel 0 [dBm]	Communication channel	Result
1	403.65	0	403.65	off	0	PASS
2	403.65	0	403.65	-97.0	0	PASS
3	403.65	6	402.75	-88.0	1	PASS

3.14 Test Conditions and Results - Discontinuation of MICS or MEDS session

3.14.1 Information

Test Information	
Reference	FCC 95.2559(a)(5) ISED RSS-243 3.6, 5.7.6
Measurement Method	EN 301 839 5.3.7.1.7
Operator	Wilfried Treffke
Date	2019-09-24

3.14.2 Limits

Limits
Cease transmission for silent period ≥ 5 s

3.14.3 Setup

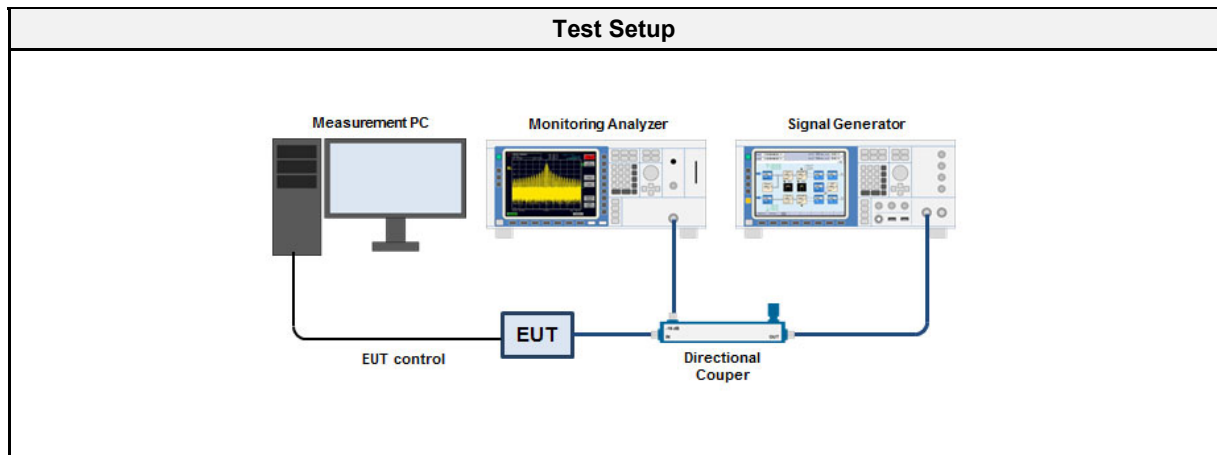

3.14.4 Equipment

Test Equipment - Radiated measurement					
Description	Manufacturer	Model	Identifier	Cal. Date	Cal. Due
Spectrum Analyzer	R&S	FSU 26	EF01407	2019-07	2020-07
Signal Generator	R&S	SMU200A	EF00004	2019-07	2020-07

3.14.5 Procedure

Test Procedure
<p>1. By administration commands the following channel occupation is simulated to the device so that the EUT can only send on frequency f_c.</p> <div style="text-align: center; margin: 10px 0;"> </div> <p>2. A CW signal is generated by the signal generator on frequency f_c with a level 9 dB higher than the calculated LBT threshold level. It is determined that the EUT communicates on LIC channel.</p> <p>3. The CW interferer level is reduced to a level 3 dB below the threshold level and the ULP-AMI is switched off. The transmission of the EUT (ULP-AMI-P) is captured until the transmission is finished and the time is recorded.</p> <p>4. The ULP-AMI is enabled again and the communication session should not restart on LIC channel.</p>

3.14.6 Results

Test Results - Transmission time				
LIC channel [MHz]	Interferer channel [MHz]	Interferer level [dBm]	Transmission time [s]	Limit
403.65	403.65	-85	0.1	≥ 5 s

LIC channel [MHz]	Interferer channel [MHz]	Interferer level [dBm]	Restart next communication channel [MHz]	Verdict
403.65	403.65	-97	403.65	PASS

Spectrum access protocol - Discontinuation of MICS session

Project Number: G0M-1908-8377
 Applicant: BIOTRONIK SE & Co. KG
 Model Description: CardioMessenger Smart / Telemonitorig System
 Model: CardioMessenger Smart 4G
 Test Sample ID: 25555
 Operator: W. Treffke
 Test Site: Eurofins Product Service GmbH
 Test Date: 2019-09-24
 Operating Conditions: Tnom/Vnom
 Mode: Connection establish on channel 6
 Note 1: Limit: < 5 sec
 Note 2: Result: 0.1 sec, restart on channel 5
 Note 3: Pass

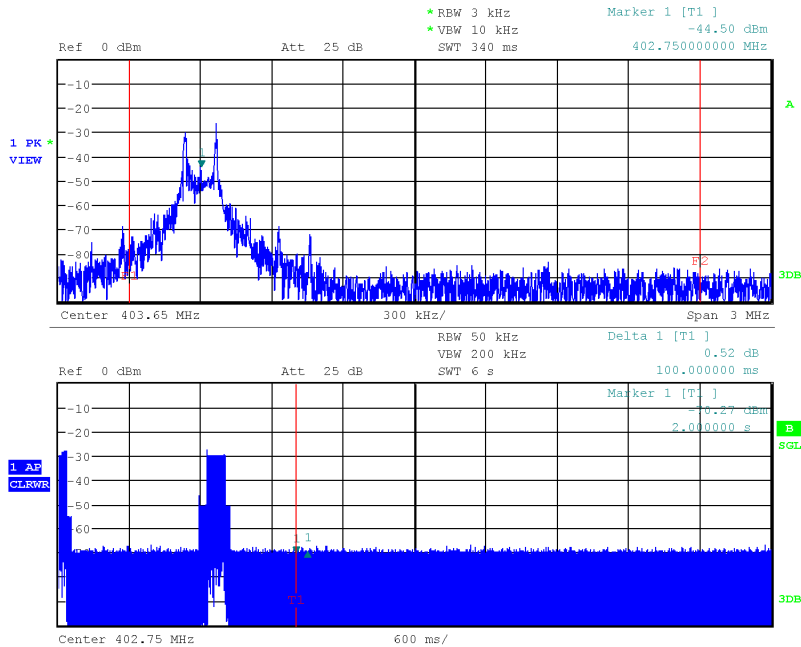

Date: 24.SEP.2019 15:23:29

ANNEX A Transmitter output power

Radiated power according to FCC part 95 MedRadio (402-405MHz)

Order number: G0M-1908-8377

Applicant: BIOTRONIK SE & Co. KG
 EUT Name: CardioMessenger Smart / Telemonitoring System
 Model: CardioMessenger Smart 4G
 Test Site: Eurofins Product Service GmbH
 Operator: Wilfried Treffke
 Test Conditions: Tnom: 22°C, Vnom: 120 VAC (5V AC/DC adaptor)
 Antenna: Rohde & Schwarz HL 223, Horizontal
 Measurement distance: 3 m
 Mode: Tx; CW; 402.45 MHz
 Test Date: 2019-09-23
 Note: Tx Power EIRP

Index 1

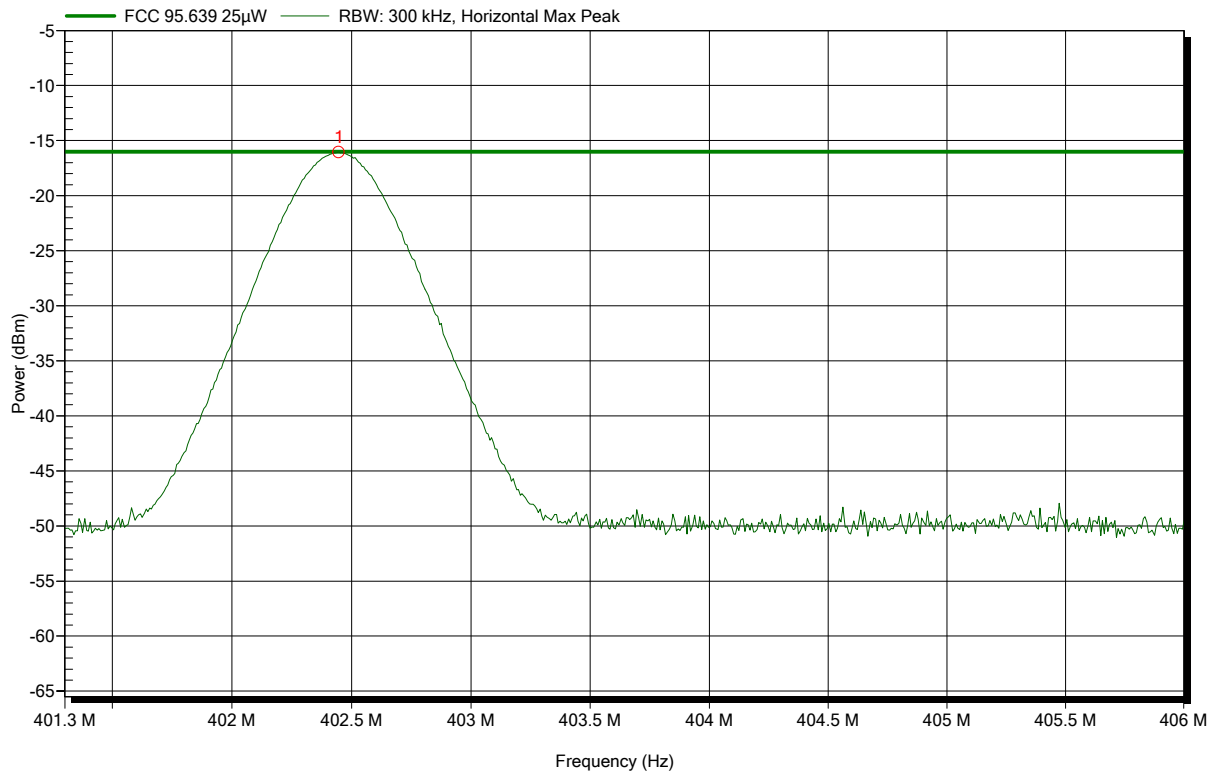

Frequency	Peak	Peak Limit	Peak Difference	Peak Status
402.445 MHz	-16 dBm	-16 dBm	-0.04 dB	Pass

Radiated power according to FCC part 95 MedRadio (402-405MHz)

Order number: G0M-1908-8377

Applicant: BIOTRONIK SE & Co. KG
 EUT Name: CardioMessenger Smart / Telemonitoring System
 Model: CardioMessenger Smart 4G
 Test Site: Eurofins Product Service GmbH
 Operator: Wilfried Treffke
 Test Conditions: Tnom: 22°C, Vnom: 120 VAC (5V AC/DC adaptor)
 Antenna: Rohde & Schwarz HL 223, Vertical
 Measurement distance: 3 m
 Mode: Tx; CW; 402.45 MHz
 Test Date: 2019-09-23
 Note: Tx Power EIRP

Index 3

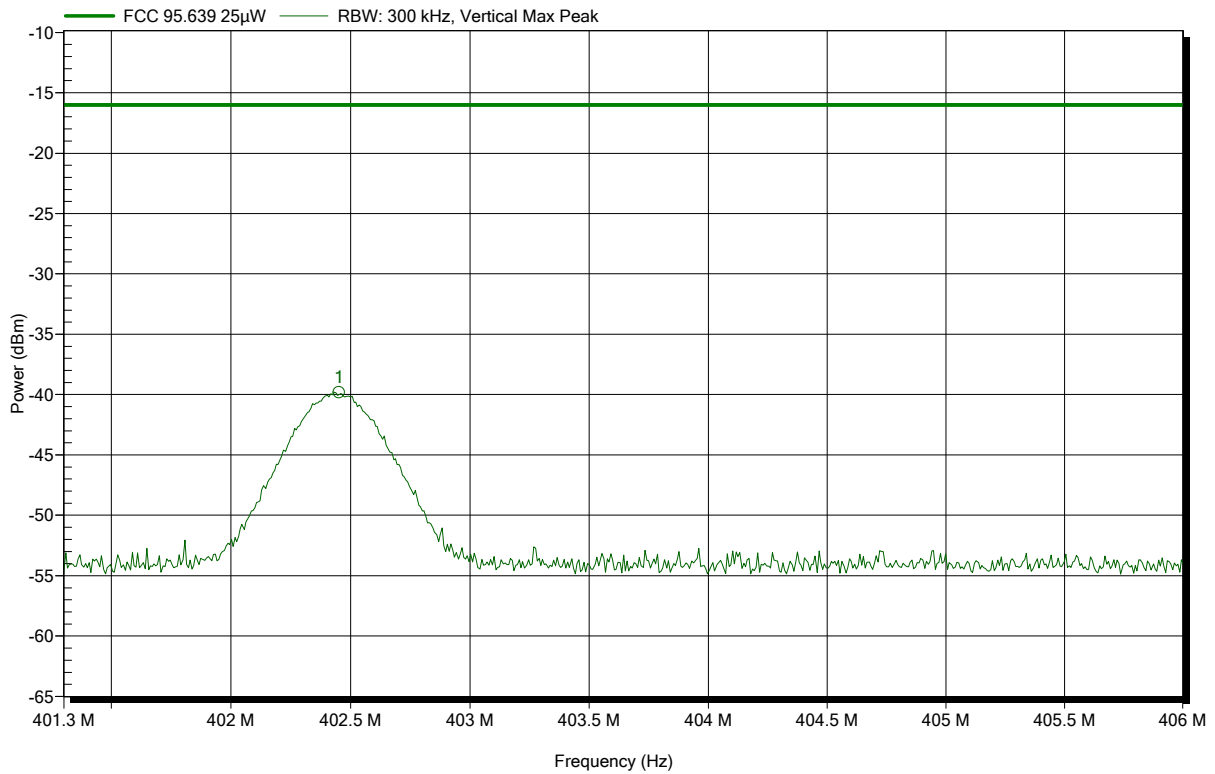

Frequency	Peak	Peak Limit	Peak Difference	Peak Status
402.451 MHz	-39.8 dBm	-16 dBm	-23.81 dB	Pass

Radiated power according to FCC part 95 MedRadio (402-405MHz)

Order number: G0M-1908-8377

Applicant: BIOTRONIK SE & Co. KG
 EUT Name: CardioMessenger Smart / Telemonitoring System
 Model: CardioMessenger Smart 4G
 Test Site: Eurofins Product Service GmbH
 Operator: Wilfried Treffke
 Test Conditions: Tnom: 22°C, Vnom: 120 VAC (5V AC/DC adaptor)
 Antenna: Rohde & Schwarz HL 223, Horizontal
 Measurement distance: 3 m
 Mode: Tx; CW; 404.85 MHz
 Test Date: 2019-09-23
 Note: Tx Power EIRP

Index 5

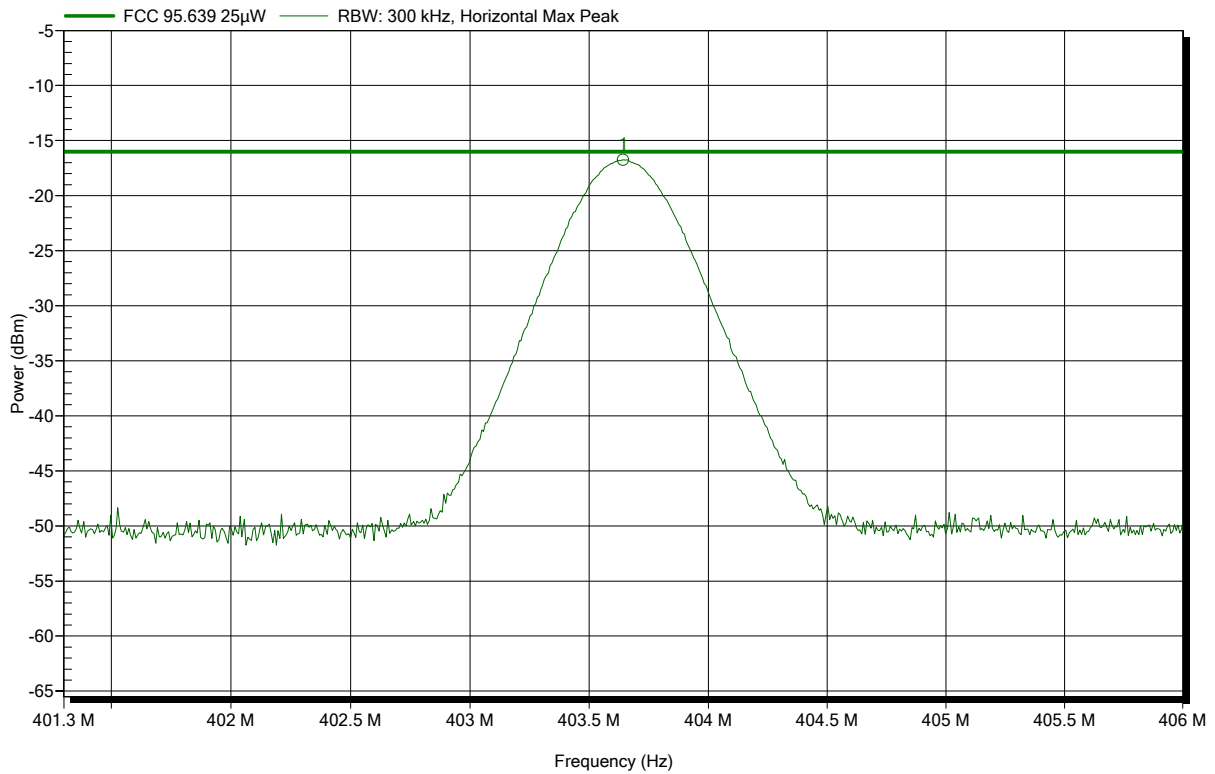

Frequency	Peak	Peak Limit	Peak Difference	Peak Status
403.642 MHz	-16.7 dBm	-16 dBm	-0.74 dB	Pass

Radiated power according to FCC part 95 MedRadio (402-405MHz)

Order number: G0M-1908-8377

Applicant: BIOTRONIK SE & Co. KG
 EUT Name: CardioMessenger Smart / Telemonitoring System
 Model: CardioMessenger Smart 4G
 Test Site: Eurofins Product Service GmbH
 Operator: Wilfried Treffke
 Test Conditions: Tnom: 22°C, Vnom: 120 VAC (5V AC/DC adaptor)
 Antenna: Rohde & Schwarz HL 223, Vertical
 Measurement distance: 3 m
 Mode: Tx; CW; 403.65 MHz
 Test Date: 2019-09-23
 Note: Tx Power EIRP

Index 4

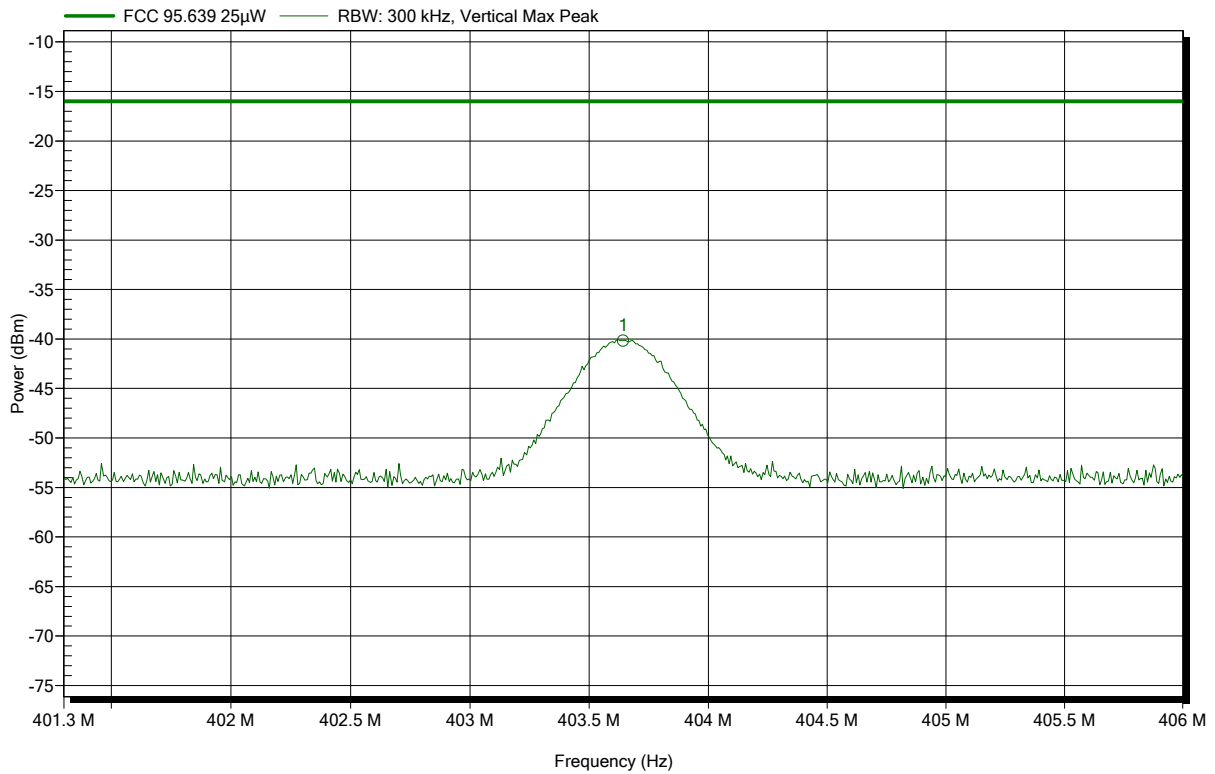

Frequency	Peak	Peak Limit	Peak Difference	Peak Status
403.642 MHz	-40.2 dBm	-16 dBm	-24.17 dB	Pass

Radiated power according to FCC part 95 MedRadio (402-405MHz)

Order number: G0M-1908-8377

Applicant: BIOTRONIK SE & Co. KG
 EUT Name: CardioMessenger Smart / Telemonitoring System
 Model: CardioMessenger Smart 4G
 Test Site: Eurofins Product Service GmbH
 Operator: Wilfried Treffke
 Test Conditions: Tnom: 22°C, Vnom: 120 VAC (5V AC/DC adaptor)
 Antenna: Rohde & Schwarz HL 223, Horizontal
 Measurement distance: 3 m
 Mode: Tx; CW; 403.65 MHz
 Test Date: 2019-09-23
 Note: Tx Power EIRP

Index 6

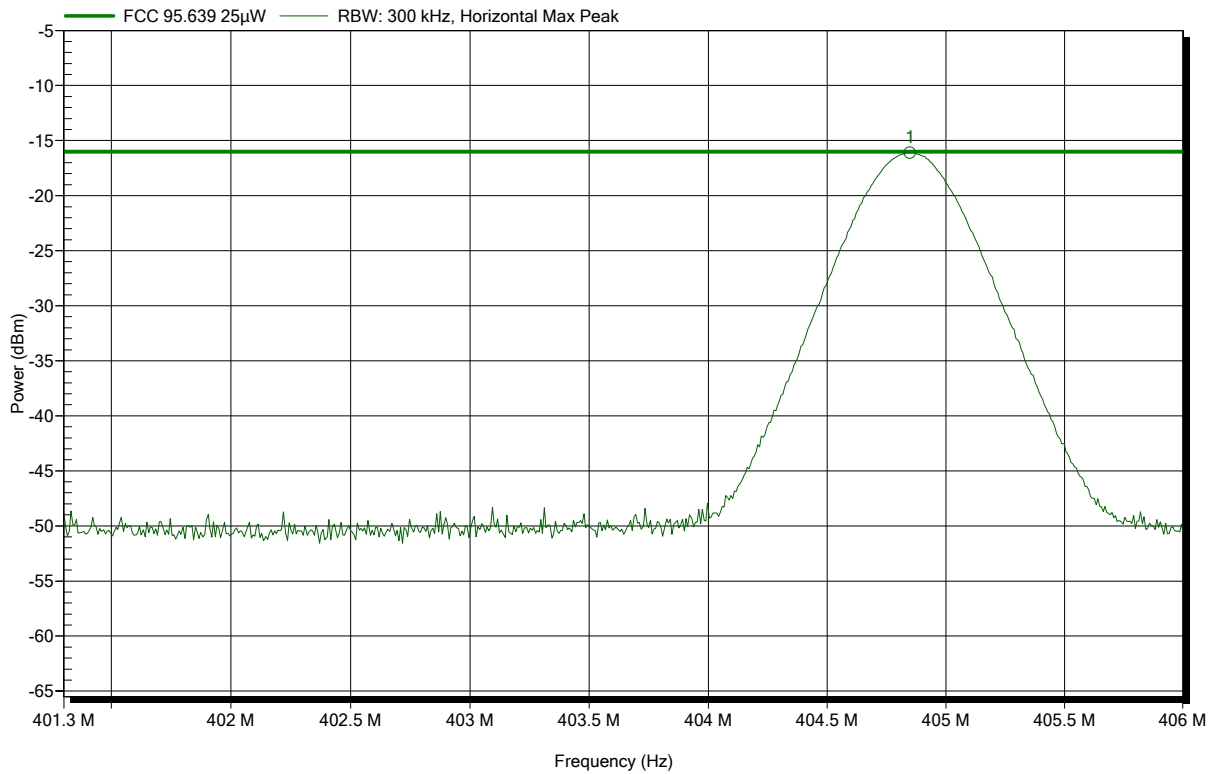

Frequency	Peak	Peak Limit	Peak Difference	Peak Status
404.848 MHz	-16.1 dBm	-16 dBm	-0.1 dB	Pass

Radiated power according to FCC part 95 MedRadio (402-405MHz)

Order number: G0M-1908-8377

Applicant: BIOTRONIK SE & Co. KG
 EUT Name: CardioMessenger Smart / Telemonitoring System
 Model: CardioMessenger Smart 4G
 Test Site: Eurofins Product Service GmbH
 Operator: Wilfried Treffke
 Test Conditions: Tnom: 22°C, Vnom: 120 VAC (5V AC/DC adaptor)
 Antenna: Rohde & Schwarz HL 223, Vertical
 Measurement distance: 3 m
 Mode: Tx; CW; 404.85 MHz
 Test Date: 2019-09-23
 Note: Tx Power EIRP

Index 8

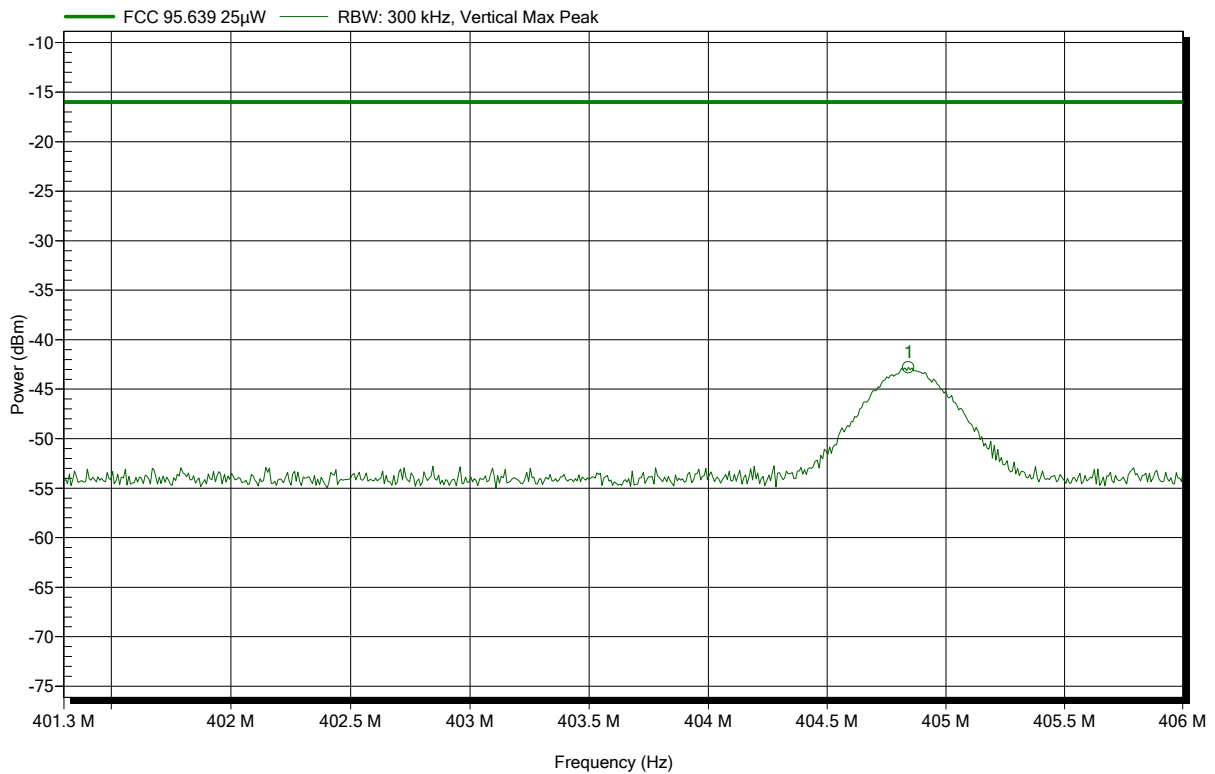

Frequency	Peak	Peak Limit	Peak Difference	Peak Status
404.84 MHz	-42.8 dBm	-16 dBm	-26.79 dB	Pass

Radiated power according to FCC part 95 MedRadio (402-405MHz)

Order number: G0M-1908-8377

Applicant: BIOTRONIK SE & Co. KG
 EUT Name: CardioMessenger Smart / Telemonitoring System
 Model: CardioMessenger Smart 4G
 Test Site: Eurofins Product Service GmbH
 Operator: Wilfried Treffke
 Test Conditions: Tnom: 22°C, Vnom: 120 VAC (5V AC/DC adaptor)
 Antenna: Rohde & Schwarz HL 223, Horizontal
 Measurement distance: 3 m
 Mode: Tx; CW; 402.45 MHz
 Test Date: 2019-09-23
 Note: Power dBµV/m ERP

Index 2

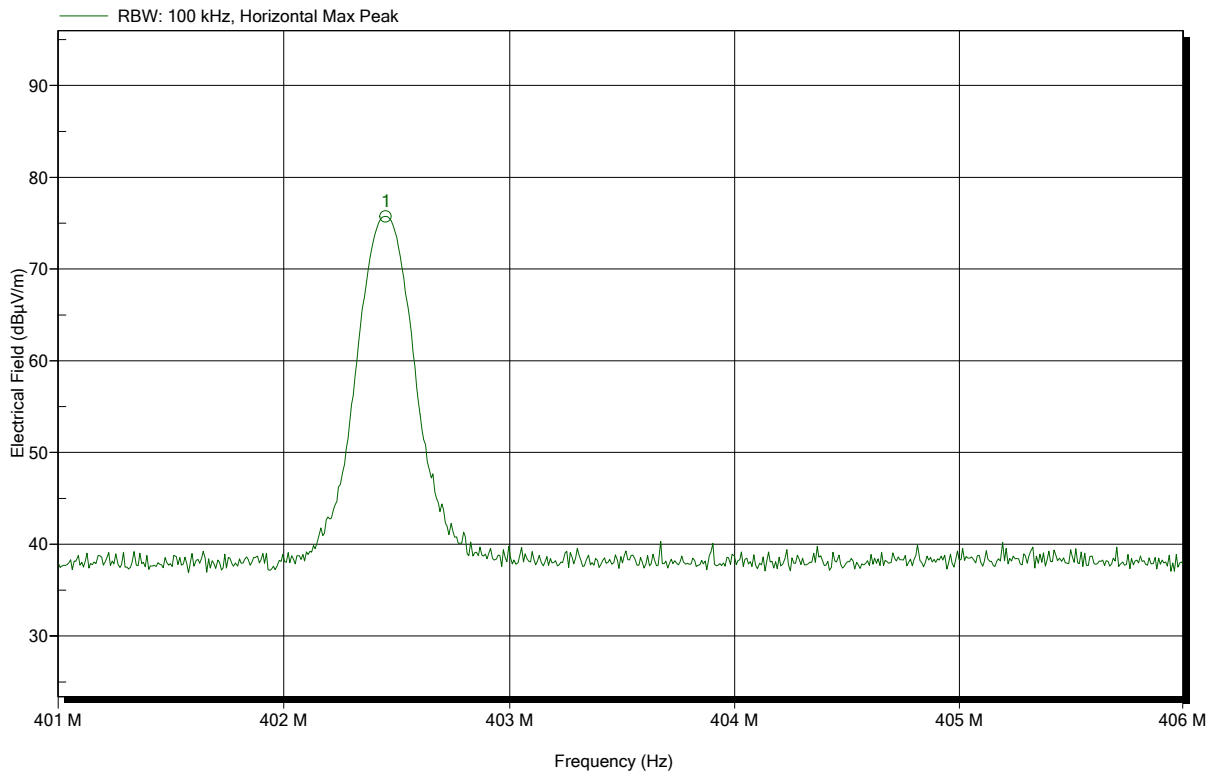

Frequency	Peak
402.45 MHz	75.75 dBµV/m

Radiated power according to FCC part 95 MedRadio (402-405MHz)

Order number: G0M-1908-8377

Applicant: BIOTRONIK SE & Co. KG
 EUT Name: CardioMessenger Smart / Telemonitoring System
 Model: CardioMessenger Smart 4G
 Test Site: Eurofins Product Service GmbH
 Operator: Wilfried Treffke
 Test Conditions: Tnom: 22°C, Vnom: 120 VAC (5V AC/DC adaptor)
 Antenna: Rohde & Schwarz HL 223, Horizontal
 Measurement distance: 3 m
 Mode: Tx; CW; 404.85 MHz
 Test Date: 2019-09-23
 Note: Power dBµV/m ERP

Index 7

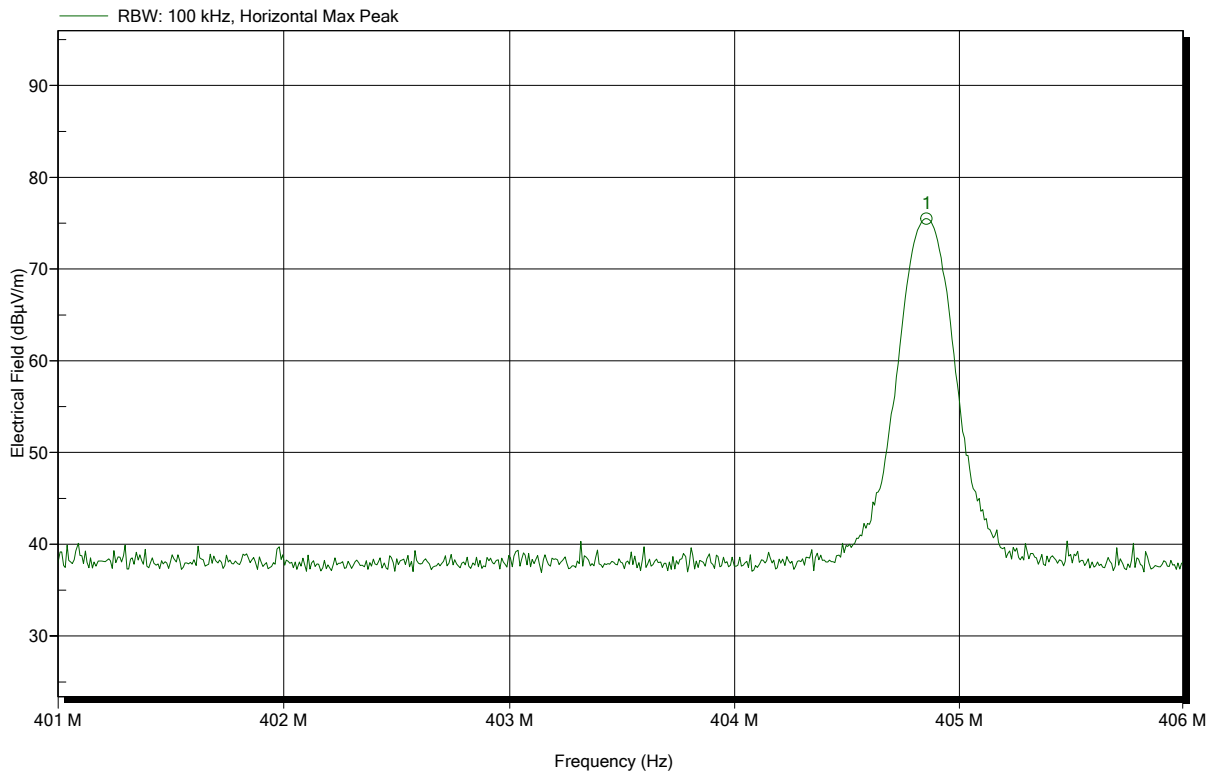

Frequency	Peak
404.854 MHz	75.5 dBµV/m

ANNEX C Band-edge and In-band Emissions

Spurious emissions according to FCC part 95 MedRadio (402-405MHz)

Project number: G0M-1908-8377

Applicant: BIOTRONIK SE & Co. KG
 EUT Name: CardioMessenger Smart / Telemonitoring System
 Model: CardioMessenger Smart 4G
 Test Site: Eurofins Product Service GmbH
 Operator: Wilfried Treffke
 Test Conditions: Tnom: 22°C, Vnom: 120 VAC (5V AC/DC adaptor)
 Antenna: Rohde & Schwarz HL 223, Horizontal
 Measurement distance: 3 m
 Mode: TX; 2-FSK; 402.45 MHz
 Test Date: 2019-09-23
 Note: Band-edge

Index 24

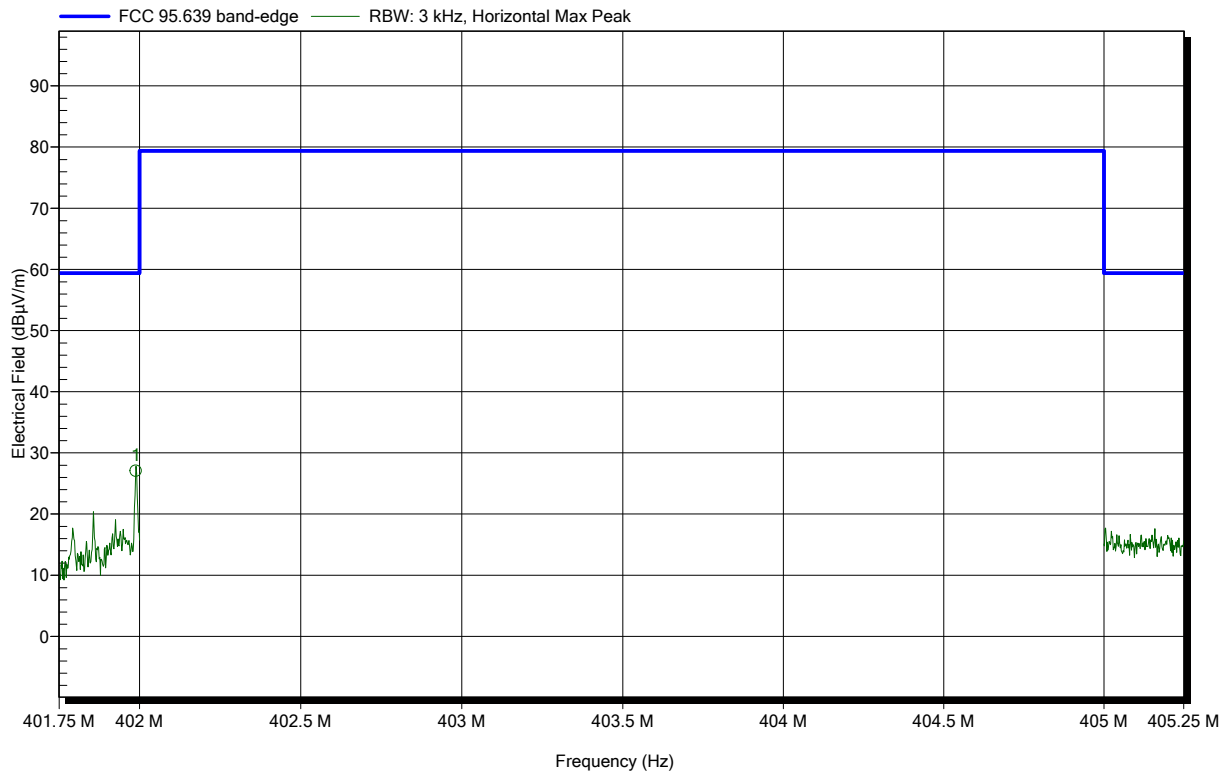

Frequency	Peak	Peak Limit	Peak Difference	Peak Status
401.988 MHz	27.1 dBµV/m	59.4 dBµV/m	-32.3 dB	Pass

Spurious emissions according to FCC part 95 MedRadio (402-405MHz)

Project number: G0M-1908-8377

Applicant: BIOTRONIK SE & Co. KG
 EUT Name: CardioMessenger Smart / Telemonitoring System
 Model: CardioMessenger Smart 4G
 Test Site: Eurofins Product Service GmbH
 Operator: Wilfried Treffke
 Test Conditions: Tnom: 22°C, Vnom: 120 VAC (5V AC/DC adaptor)
 Antenna: Rohde & Schwarz HL 223, Vertical
 Measurement distance: 3 m
 Mode: TX; 2-FSK; 402.45 MHz
 Test Date: 2019-09-23
 Note: Band-edge

Index 28

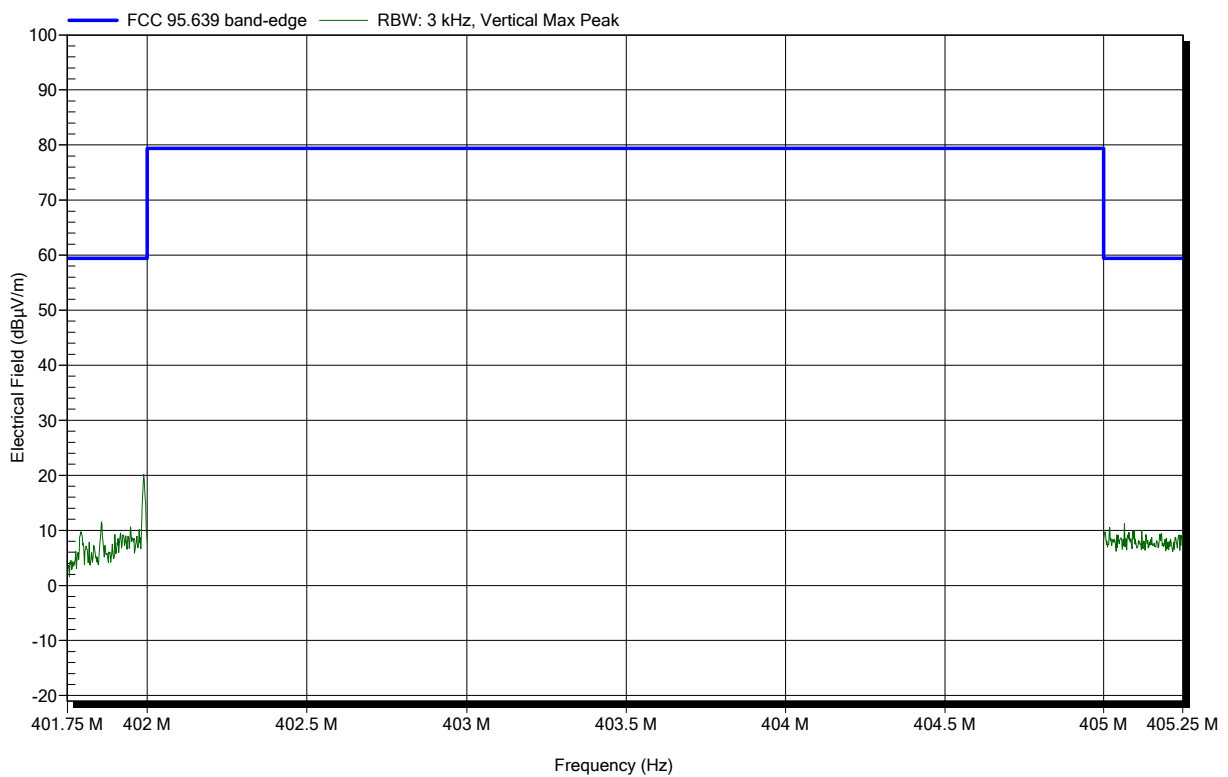

Spurious emissions according to FCC part 95 MedRadio (402-405MHz)

Project number: G0M-1908-8377

Applicant: BIOTRONIK SE & Co. KG
 EUT Name: CardioMessenger Smart / Telemonitoring System
 Model: CardioMessenger Smart 4G
 Test Site: Eurofins Product Service GmbH
 Operator: Wilfried Treffke
 Test Conditions: Tnom: 22°C, Vnom: 120 VAC (5V AC/DC adaptor)
 Antenna: Rohde & Schwarz HL 223, Horizontal
 Measurement distance: 3 m
 Mode: TX; 2-FSK; 402.45 MHz
 Test Date: 2019-09-23
 Note: In-band emissions

Index 25

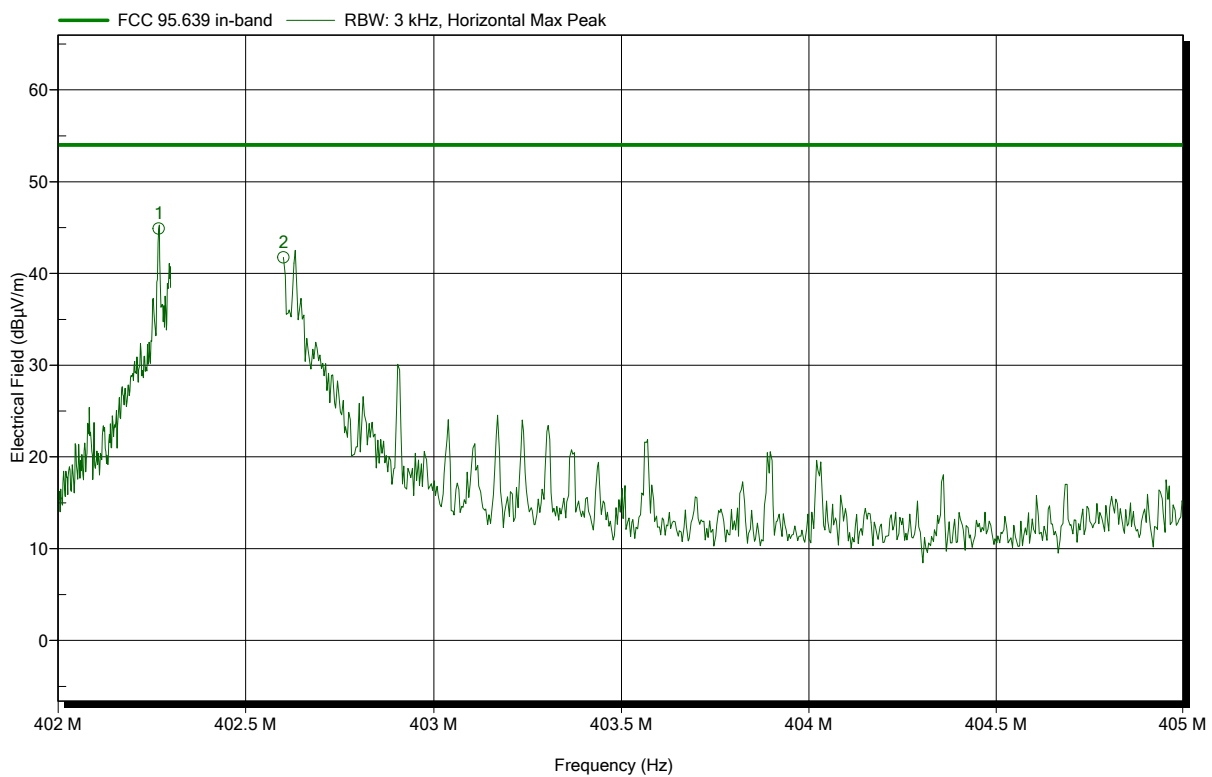

Frequency	Peak	Peak Limit	Peak Difference	Peak Status
402.268 MHz	44.91 dBµV/m	54 dBµV/m	-9.09 dB	Pass
402.6 MHz	41.76 dBµV/m	54 dBµV/m	-12.24 dB	Pass

Spurious emissions according to FCC part 95 MedRadio (402-405MHz)

Project number: G0M-1908-8377

Applicant: BIOTRONIK SE & Co. KG
 EUT Name: CardioMessenger Smart / Telemonitoring System
 Model: CardioMessenger Smart 4G
 Test Site: Eurofins Product Service GmbH
 Operator: Wilfried Treffke
 Test Conditions: Tnom: 22°C, Vnom: 120 VAC (5V AC/DC adaptor)
 Antenna: Rohde & Schwarz HL 223, Vertical
 Measurement distance: 3 m
 Mode: TX; 2-FSK; 402.45 MHz
 Test Date: 2019-09-23
 Note: In-band emissions

Index 29

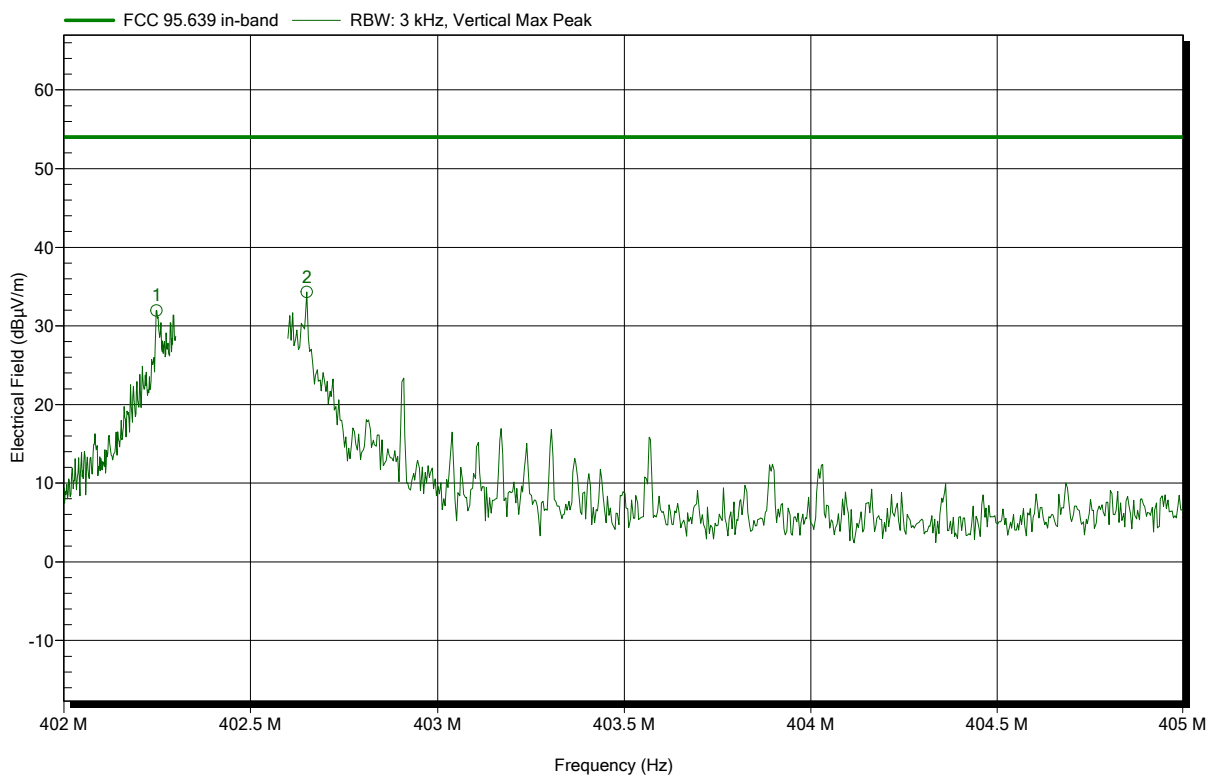

Frequency	Peak	Peak Limit	Peak Difference	Peak Status
402.248 MHz	31.94 dBµV/m	54 dBµV/m	-22.06 dB	Pass
402.65 MHz	34.34 dBµV/m	54 dBµV/m	-19.66 dB	Pass

Spurious emissions according to FCC part 95 MedRadio (402-405MHz)

Project number: G0M-1908-8377

Applicant: BIOTRONIK SE & Co. KG
 EUT Name: CardioMessenger Smart / Telemonitoring System
 Model: CardioMessenger Smart 4G
 Test Site: Eurofins Product Service GmbH
 Operator: Wilfried Treffke
 Test Conditions: Tnom: 22°C, Vnom: 120 VAC (5V AC/DC adaptor)
 Antenna: Rohde & Schwarz HL 223, Horizontal
 Measurement distance: 3 m
 Mode: TX; 2-FSK; 404.85 MHz
 Test Date: 2019-09-23
 Note: Band-edge

Index 10

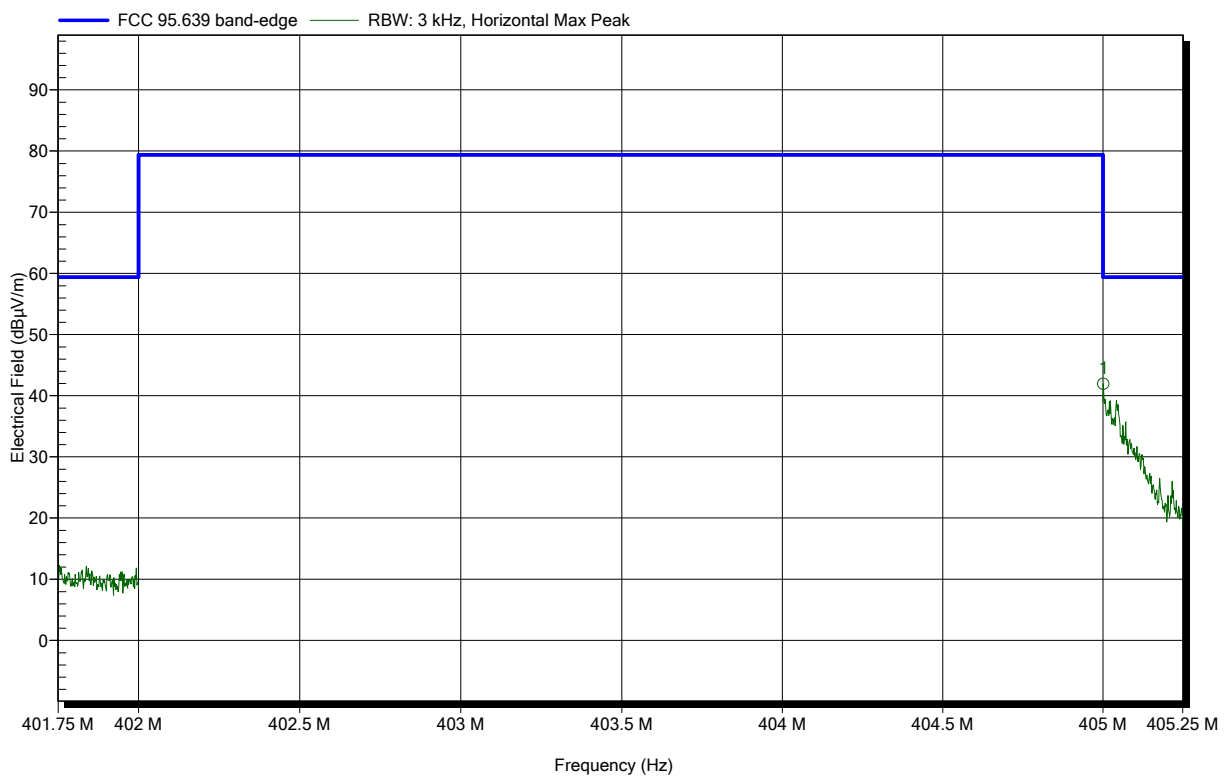

Frequency	Peak	Peak Limit	Peak Difference	Peak Status
405.001 MHz	41.98 dBµV/m	59.4 dBµV/m	-17.42 dB	Pass

Spurious emissions according to FCC part 95 MedRadio (402-405MHz)

Project number: G0M-1908-8377

Applicant: BIOTRONIK SE & Co. KG
 EUT Name: CardioMessenger Smart / Telemonitoring System
 Model: CardioMessenger Smart 4G
 Test Site: Eurofins Product Service GmbH
 Operator: Wilfried Treffke
 Test Conditions: Tnom: 22°C, Vnom: 120 VAC (5V AC/DC adaptor)
 Antenna: Rohde & Schwarz HL 223, Vertical
 Measurement distance: 3 m
 Mode: TX; 2-FSK; 404.85 MHz
 Test Date: 2019-09-23
 Note: Band-edge

Index 14

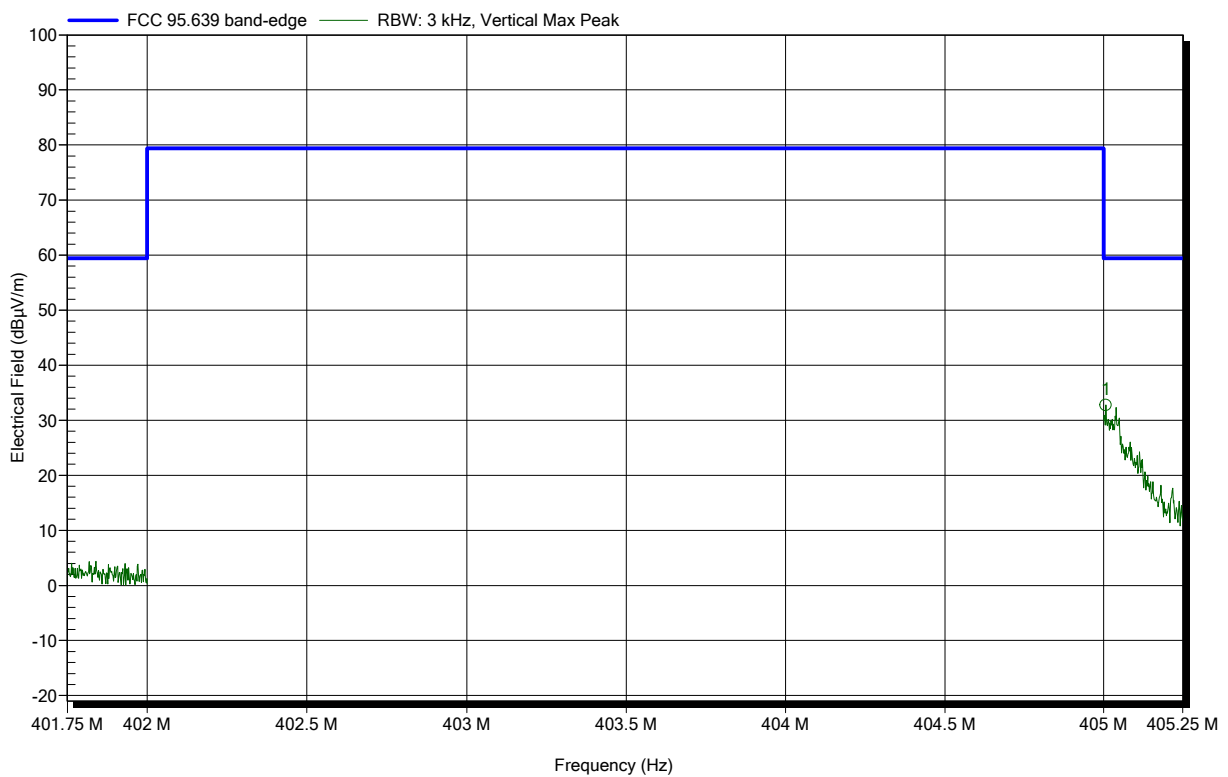

Frequency	Peak	Peak Limit	Peak Difference	Peak Status
405.006 MHz	32.78 dBµV/m	59.4 dBµV/m	-26.62 dB	Pass

Spurious emissions according to FCC part 95 MedRadio (402-405MHz)

Project number: G0M-1908-8377

Applicant: BIOTRONIK SE & Co. KG
 EUT Name: CardioMessenger Smart / Telemonitoring System
 Model: CardioMessenger Smart 4G
 Test Site: Eurofins Product Service GmbH
 Operator: Wilfried Treffke
 Test Conditions: Tnom: 22°C, Vnom: 120 VAC (5V AC/DC adaptor)
 Antenna: Rohde & Schwarz HL 223, Horizontal
 Measurement distance: 3 m
 Mode: TX; 2-FSK; 404.85 MHz
 Test Date: 2019-09-23
 Note: In-band emissions

Index 11

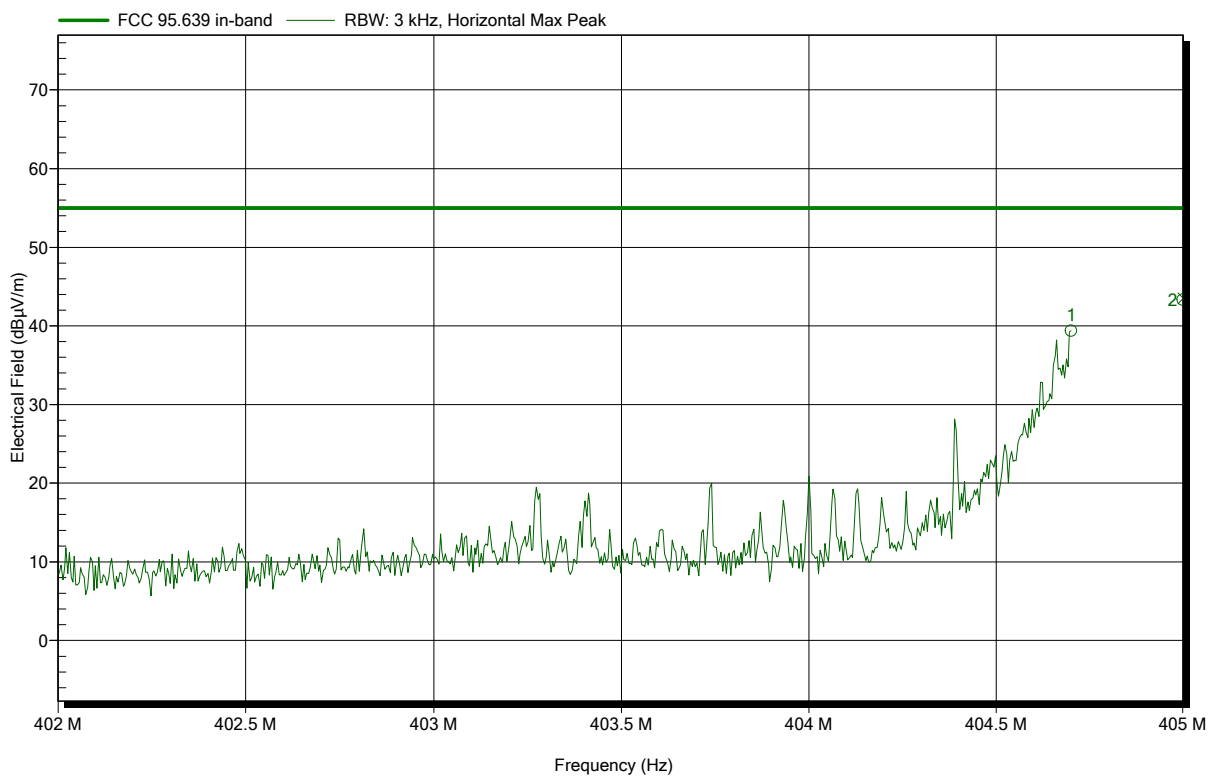

Frequency	Peak	Peak Limit	Peak Difference	Peak Status
404.7 MHz	39.4 dBµV/m	55 dBµV/m	-15.6 dB	Pass
405 MHz	43.33 dBµV/m	55 dBµV/m	-11.67 dB	Pass

Spurious emissions according to FCC part 95 MedRadio (402-405MHz)

Project number: G0M-1908-8377

Applicant: BIOTRONIK SE & Co. KG
 EUT Name: CardioMessenger Smart / Telemonitoring System
 Model: CardioMessenger Smart 4G
 Test Site: Eurofins Product Service GmbH
 Operator: Wilfried Treffke
 Test Conditions: Tnom: 22°C, Vnom: 120 VAC (5V AC/DC adaptor)
 Antenna: Rohde & Schwarz HL 223, Vertical
 Measurement distance: 3 m
 Mode: TX; 2-FSK; 404.85 MHz
 Test Date: 2019-09-23
 Note: In-band emissions

Index 15

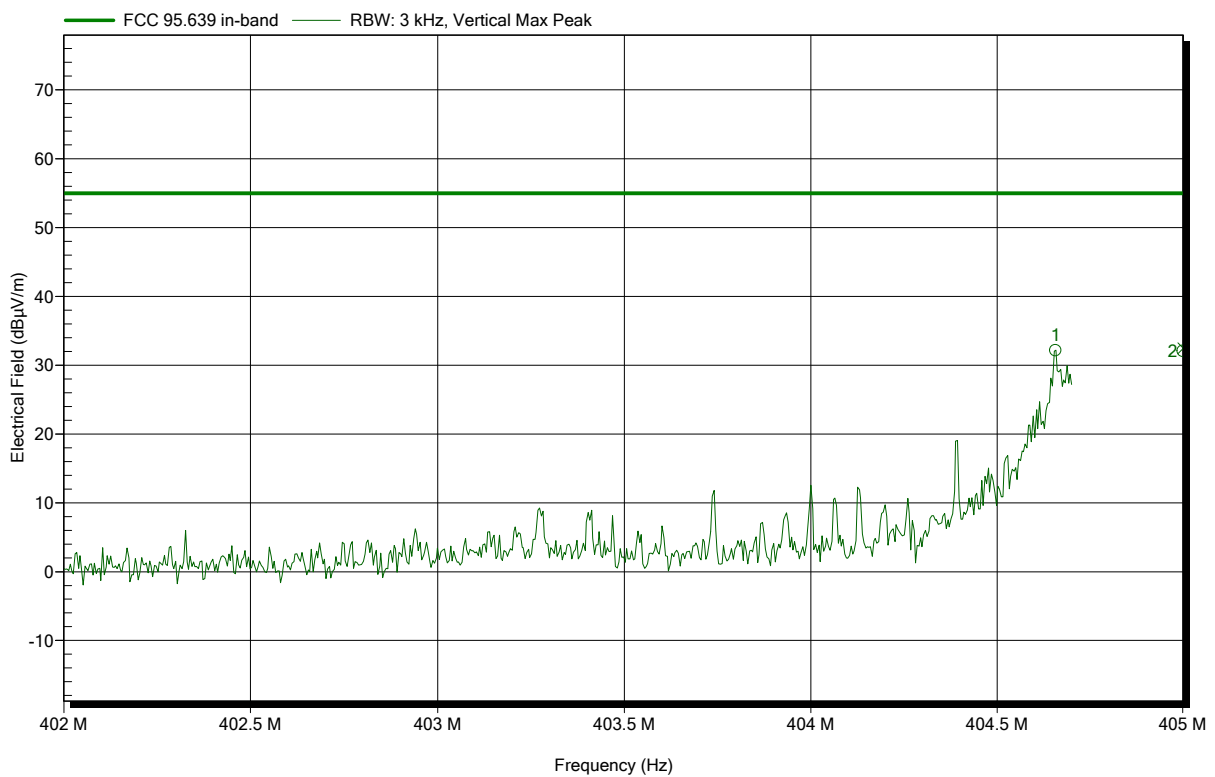

Frequency	Peak	Peak Limit	Peak Difference	Peak Status
404.657 MHz	32.17 dBµV/m	55 dBµV/m	-22.83 dB	Pass
405 MHz	32.08 dBµV/m	55 dBµV/m	-22.92 dB	Pass

ANNEX D Transmitter spurious emissions

Spurious emissions according to FCC part 95 MedRadio (402-405MHz)

Project number: G0M-1908-8377

Applicant: BIOTRONIK SE & Co. KG
 EUT Name: CardioMessenger Smart / Telemonitoring System
 Model: CardioMessenger Smart 4G
 Test Site: Eurofins Product Service GmbH
 Operator: Wilfried Treffke
 Test Conditions: Tnom: 22°C, Vnom: 120 VAC (5V AC/DC adaptor)
 Antenna: Rohde & Schwarz HK 116, Horizontal
 Measurement distance: 3 m
 Mode: TX; 2-FSK; 402.45 MHz
 Test Date: 2019-09-23
 Note:

Index 31

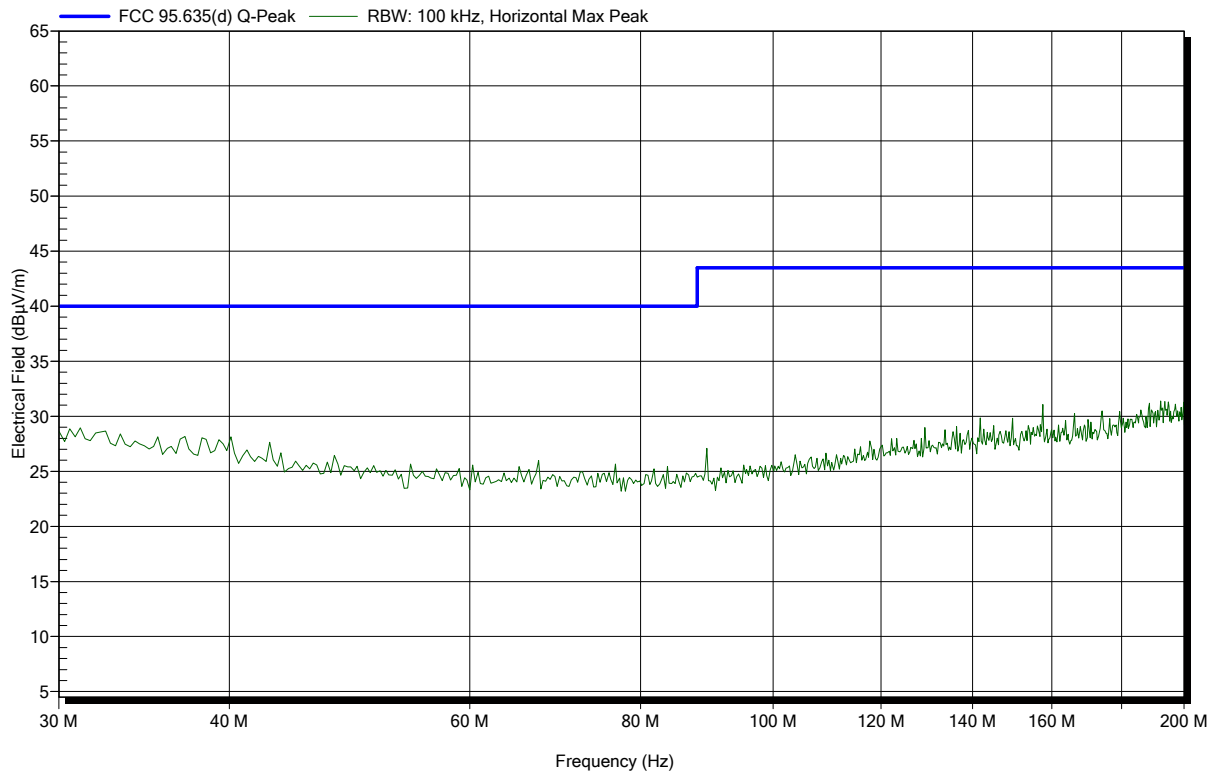

Spurious emissions according to FCC part 95 MedRadio (402-405MHz)

Project number: G0M-1908-8377

Applicant: BIOTRONIK SE & Co. KG
 EUT Name: CardioMessenger Smart / Telemonitoring System
 Model: CardioMessenger Smart 4G
 Test Site: Eurofins Product Service GmbH
 Operator: Wilfried Treffke
 Test Conditions: Tnom: 22°C, Vnom: 120 VAC (5V AC/DC adaptor)
 Antenna: Rohde & Schwarz HK 116, Vertical
 Measurement distance: 3 m
 Mode: TX; 2-FSK; 402.45 MHz
 Test Date: 2019-09-23
 Note:

Index 32

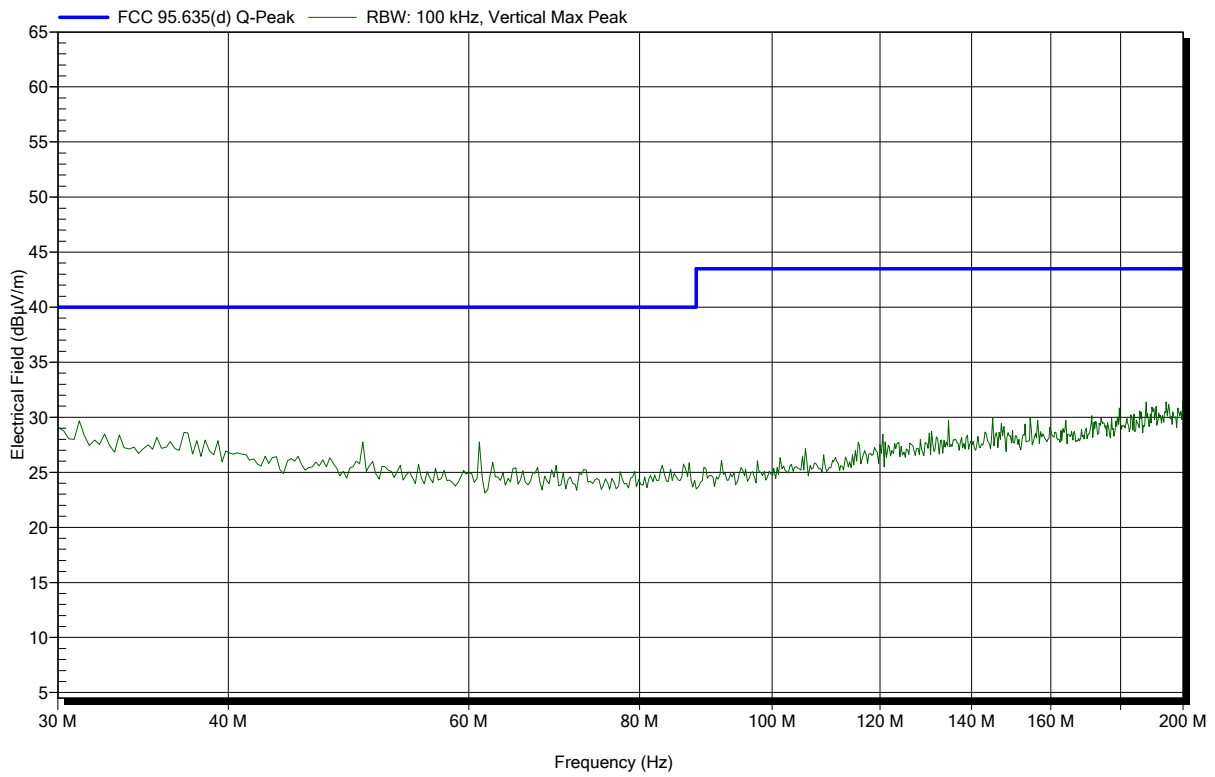

Spurious emissions according to FCC part 95 MedRadio (402-405MHz)

Project number: G0M-1908-8377

Applicant: BIOTRONIK SE & Co. KG
 EUT Name: CardioMessenger Smart / Telemonitoring System
 Model: CardioMessenger Smart 4G
 Test Site: Eurofins Product Service GmbH
 Operator: Wilfried Treffke
 Test Conditions: Tnom: 22°C, Vnom: 120 VAC (5V AC/DC adaptor)
 Antenna: Rohde & Schwarz HL 223, Horizontal
 Measurement distance: 3 m
 Mode: TX; 2-FSK; 402.45 MHz
 Test Date: 2019-09-23
 Note:

Index 23

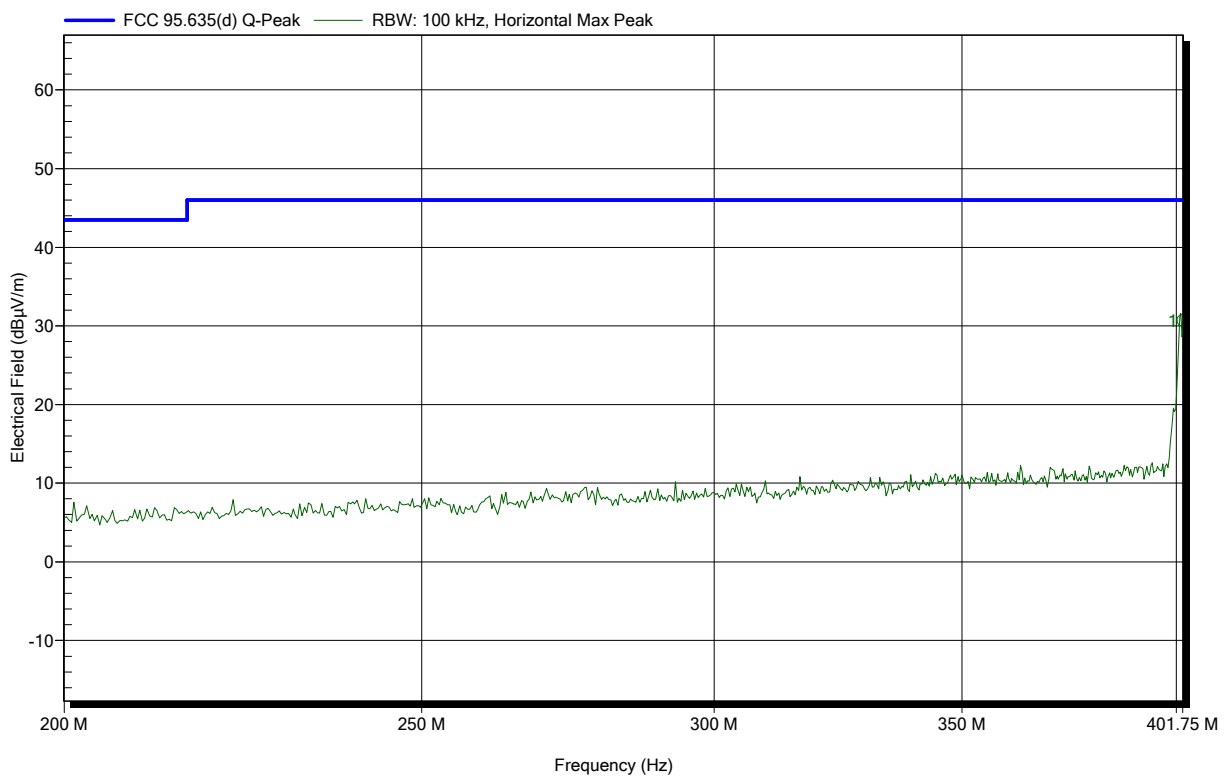

Frequency	Peak	Peak Limit	Peak Difference	Status
401.75 MHz	30.68 dBµV/m	46 dBµV/m	-15.32 dB	Pass

Spurious emissions according to FCC part 95 MedRadio (402-405MHz)

Project number: G0M-1908-8377

Applicant: BIOTRONIK SE & Co. KG
 EUT Name: CardioMessenger Smart / Telemonitoring System
 Model: CardioMessenger Smart 4G
 Test Site: Eurofins Product Service GmbH
 Operator: Wilfried Treffke
 Test Conditions: Tnom: 22°C, Vnom: 120 VAC (5V AC/DC adaptor)
 Antenna: Rohde & Schwarz HL 223, Vertical
 Measurement distance: 3 m
 Mode: TX; 2-FSK; 402.45 MHz
 Test Date: 2019-09-23
 Note:

Index 27

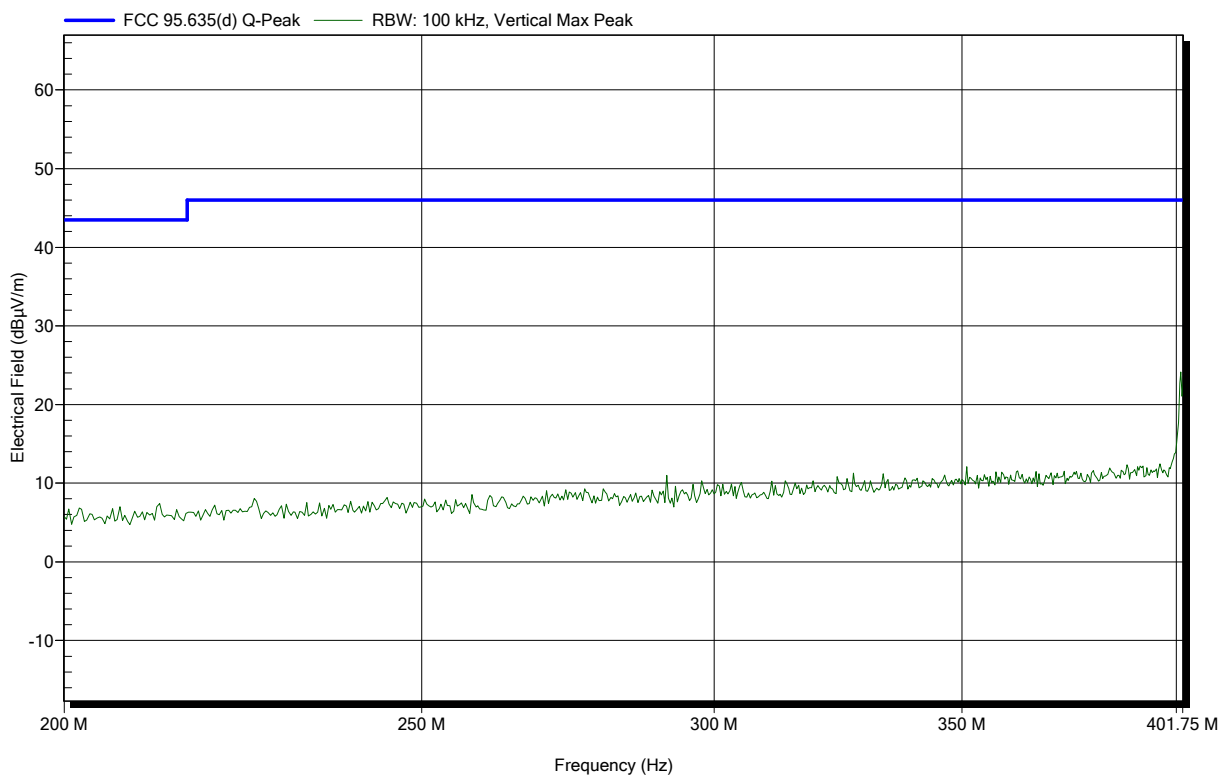

Spurious emissions according to FCC part 95 MedRadio (402-405MHz)

Project number: G0M-1908-8377

Applicant: BIOTRONIK SE & Co. KG
 EUT Name: CardioMessenger Smart / Telemonitoring System
 Model: CardioMessenger Smart 4G
 Test Site: Eurofins Product Service GmbH
 Operator: Wilfried Treffke
 Test Conditions: Tnom: 22°C, Vnom: 120 VAC (5V AC/DC adaptor)
 Antenna: Rohde & Schwarz HL 223, Horizontal
 Measurement distance: 3 m
 Mode: TX; 2-FSK; 402.45 MHz
 Test Date: 2019-09-23
 Note:

Index 26

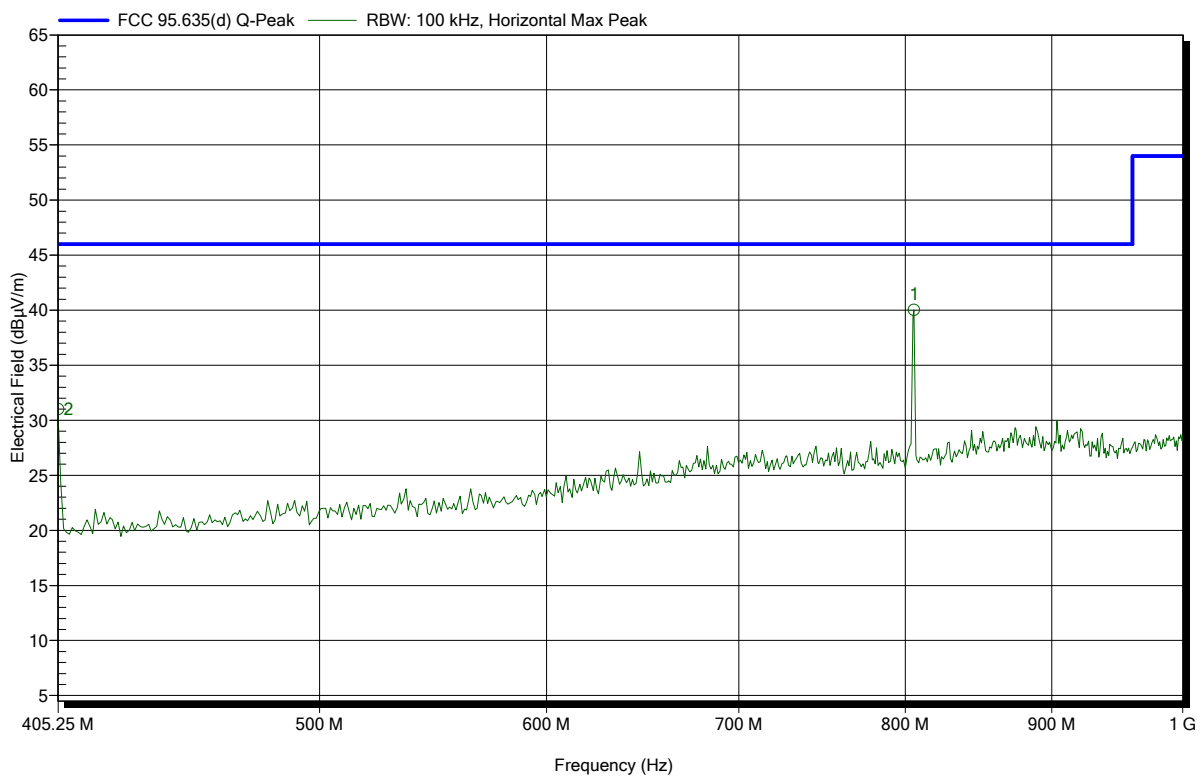

Frequency	Peak	Peak Limit	Peak Difference	Peak Status
405.25 MHz	31.02 dBµV/m	46 dBµV/m	-14.98 dB	Pass
805.563 MHz	40.04 dBµV/m	46 dBµV/m	-5.96 dB	Pass

Spurious emissions according to FCC part 95 MedRadio (402-405MHz)

Project number: G0M-1908-8377

Applicant: BIOTRONIK SE & Co. KG
 EUT Name: CardioMessenger Smart / Telemonitoring System
 Model: CardioMessenger Smart 4G
 Test Site: Eurofins Product Service GmbH
 Operator: Wilfried Treffke
 Test Conditions: Tnom: 22°C, Vnom: 120 VAC (5V AC/DC adaptor)
 Antenna: Rohde & Schwarz HL 223, Vertical
 Measurement distance: 3 m
 Mode: TX; 2-FSK; 402.45 MHz
 Test Date: 2019-09-23
 Note:

Index 30

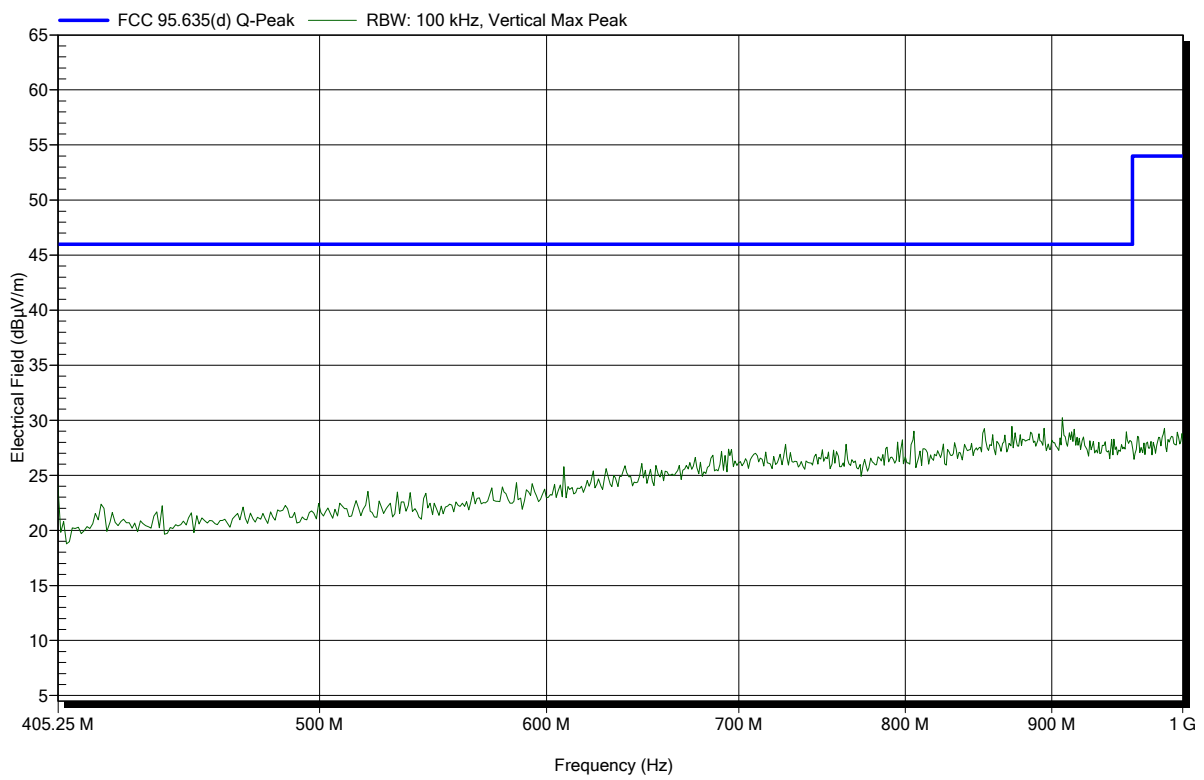

Spurious emissions according to FCC part 95 MedRadio (402-405MHz)

Project number: G0M-1908-8377

Applicant: BIOTRONIK SE & Co. KG
 EUT Name: CardioMessenger Smart / Telemonitoring System
 Model: CardioMessenger Smart 4G
 Test Site: Eurofins Product Service GmbH
 Operator: Wilfried Treffke
 Test Conditions: Tnom: 22°C, Vnom: 120 VAC (5V AC/DC adaptor)
 Antenna: Schwarzbeck BBHA 9120D, Horizontal
 Measurement distance: 3 m
 Mode: TX; 2-FSK; 402.45 MHz
 Test Date: 2019-09-23
 Note:

Index 21

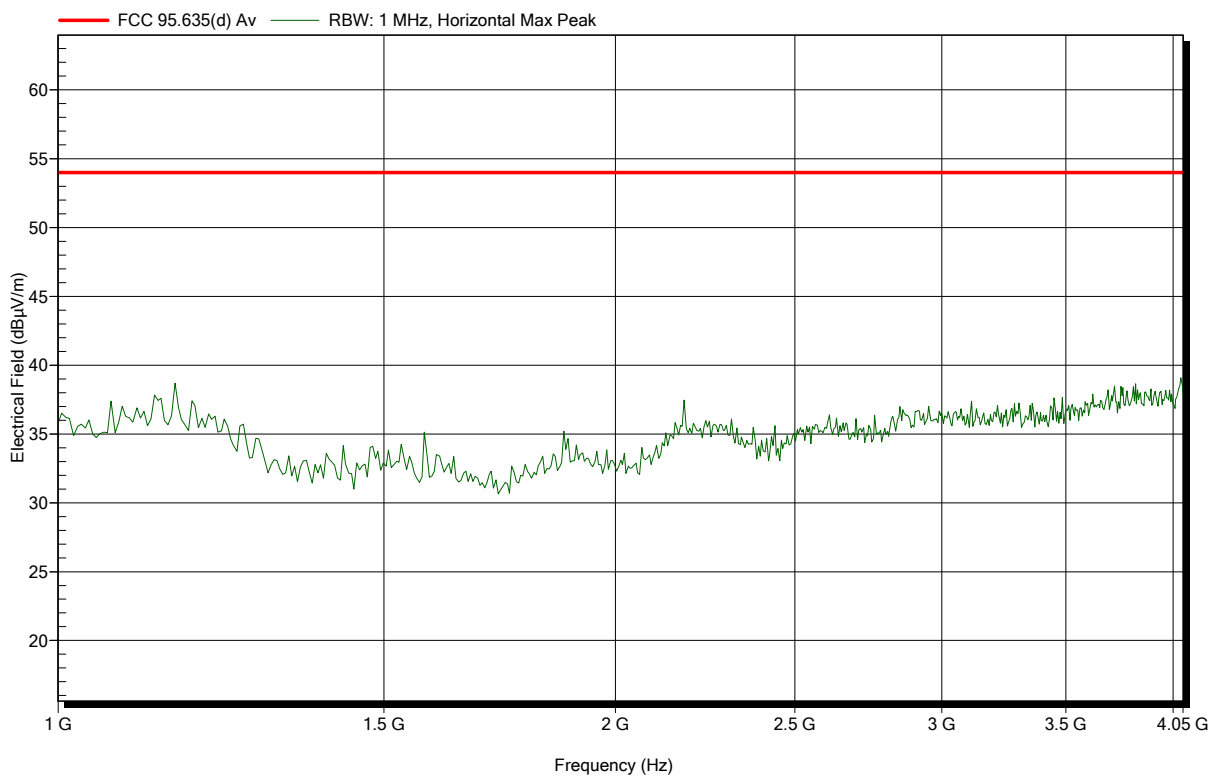

Spurious emissions according to FCC part 95 MedRadio (402-405MHz)

Project number: G0M-1908-8377

Applicant: BIOTRONIK SE & Co. KG
 EUT Name: CardioMessenger Smart / Telemonitoring System
 Model: CardioMessenger Smart 4G
 Test Site: Eurofins Product Service GmbH
 Operator: Wilfried Treffke
 Test Conditions: Tnom: 22°C, Vnom: 120 VAC (5V AC/DC adaptor)
 Antenna: Schwarzbeck BBHA 9120D, Vertical
 Measurement distance: 3 m
 Mode: TX; 2-FSK; 402.45 MHz
 Test Date: 2019-09-23
 Note:

Index 22

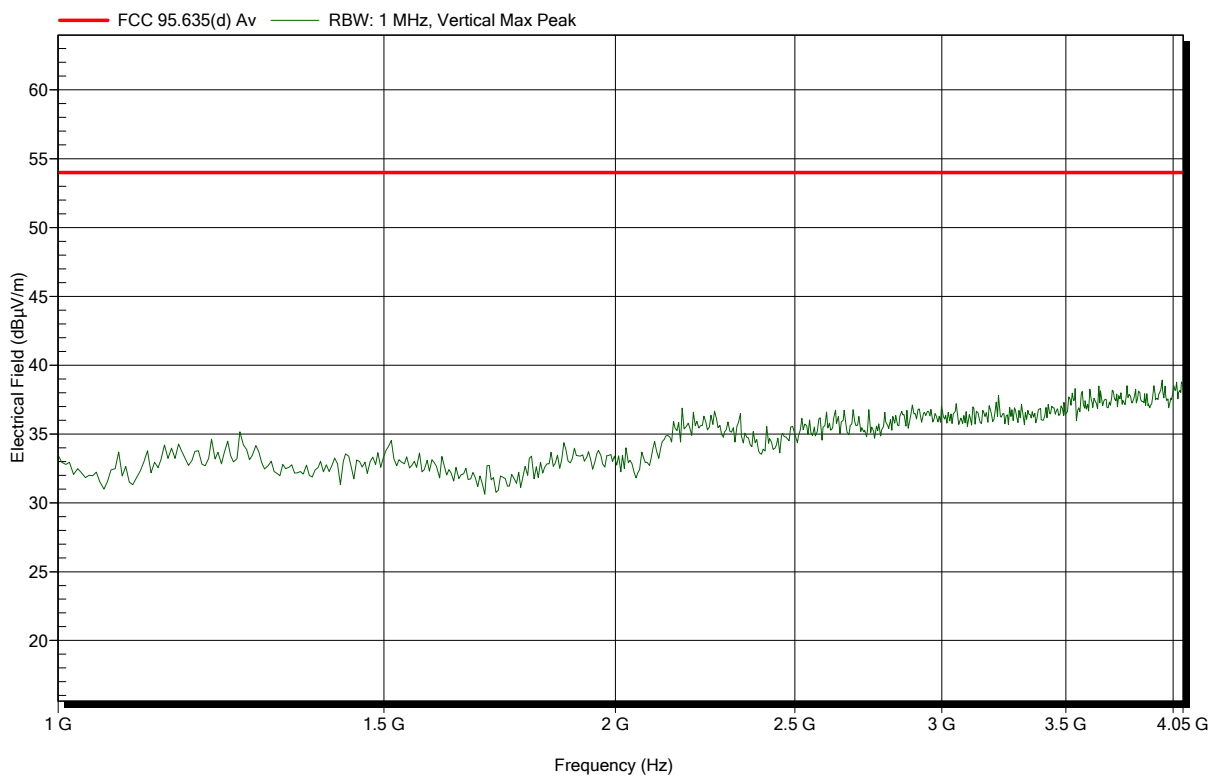

Spurious emissions according to FCC part 95 MedRadio (402-405MHz)

Project number: G0M-1908-8377

Applicant: BIOTRONIK SE & Co. KG
 EUT Name: CardioMessenger Smart / Telemonitoring System
 Model: CardioMessenger Smart 4G
 Test Site: Eurofins Product Service GmbH
 Operator: Wilfried Treffke
 Test Conditions: Tnom: 22°C, Vnom: 120 VAC (5V AC/DC adaptor)
 Antenna: Rohde & Schwarz HK 116, Horizontal
 Measurement distance: 3 m
 Mode: TX; 2-FSK; 404.85 MHz
 Test Date: 2019-09-23
 Note:

Index 19

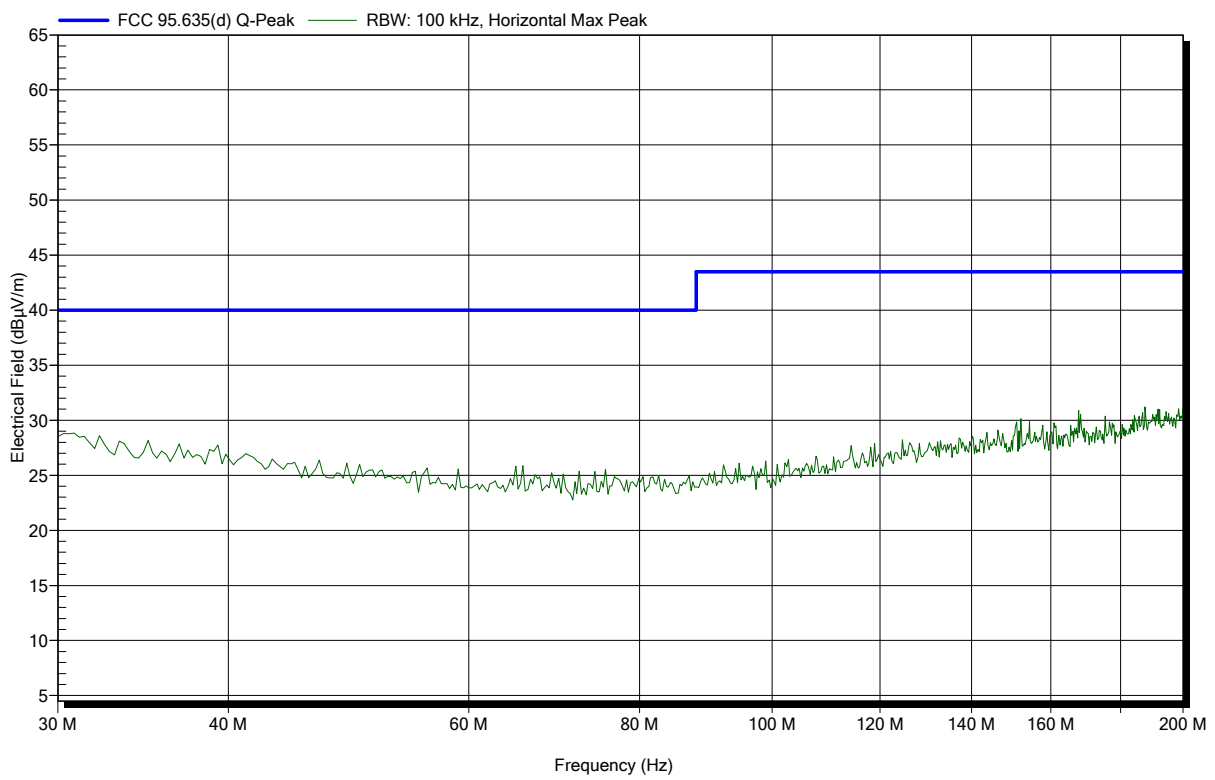

Spurious emissions according to FCC part 95 MedRadio (402-405MHz)

Project number: G0M-1908-8377

Applicant: BIOTRONIK SE & Co. KG
 EUT Name: CardioMessenger Smart / Telemonitoring System
 Model: CardioMessenger Smart 4G
 Test Site: Eurofins Product Service GmbH
 Operator: Wilfried Treffke
 Test Conditions: Tnom: 22°C, Vnom: 120 VAC (5V AC/DC adaptor)
 Antenna: Rohde & Schwarz HK 116, Vertical
 Measurement distance: 3 m
 Mode: TX; 2-FSK; 404.85 MHz
 Test Date: 2019-09-23
 Note:

Index 20

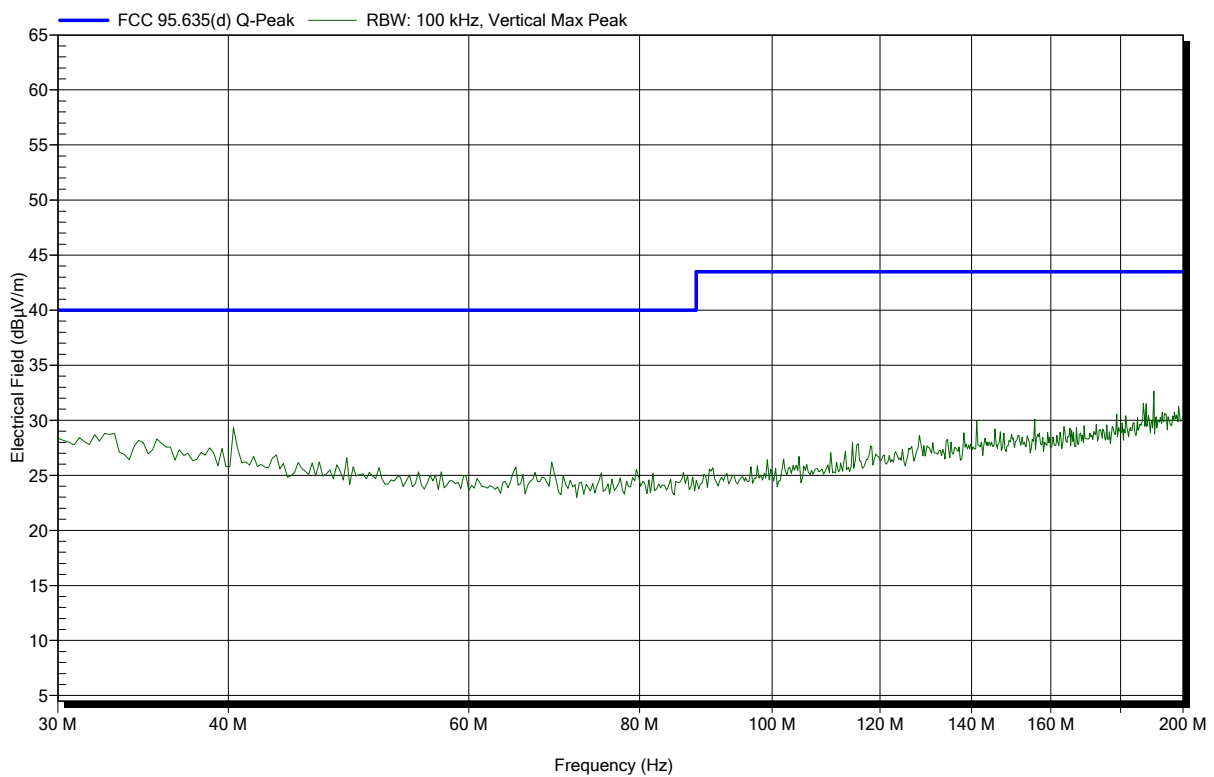

Spurious emissions according to FCC part 95 MedRadio (402-405MHz)

Project number: G0M-1908-8377

Applicant: BIOTRONIK SE & Co. KG
 EUT Name: CardioMessenger Smart / Telemonitoring System
 Model: CardioMessenger Smart 4G
 Test Site: Eurofins Product Service GmbH
 Operator: Wilfried Treffke
 Test Conditions: Tnom: 22°C, Vnom: 120 VAC (5V AC/DC adaptor)
 Antenna: Rohde & Schwarz HL 223, Horizontal
 Measurement distance: 3 m
 Mode: TX; 2-FSK; 404.85 MHz
 Test Date: 2019-09-23
 Note:

Index 9

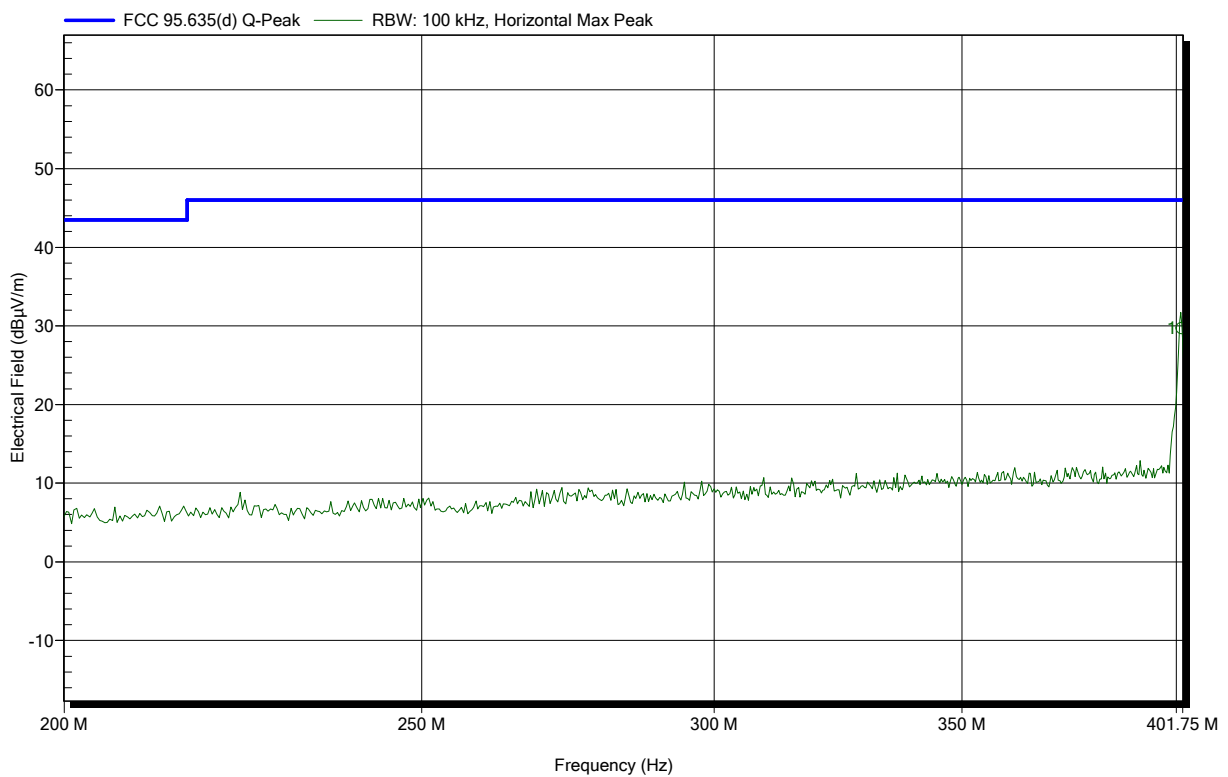

Frequency	Peak	Peak Limit	Peak Difference	Status
401.427 MHz	29.72 dBµV/m	46 dBµV/m	-16.28 dB	Pass

Spurious emissions according to FCC part 95 MedRadio (402-405MHz)

Project number: G0M-1908-8377

Applicant: BIOTRONIK SE & Co. KG
 EUT Name: CardioMessenger Smart / Telemonitoring System
 Model: CardioMessenger Smart 4G
 Test Site: Eurofins Product Service GmbH
 Operator: Wilfried Treffke
 Test Conditions: Tnom: 22°C, Vnom: 120 VAC (5V AC/DC adaptor)
 Antenna: Rohde & Schwarz HL 223, Vertical
 Measurement distance: 3 m
 Mode: TX; 2-FSK; 404.85 MHz
 Test Date: 2019-09-23
 Note:

Index 13

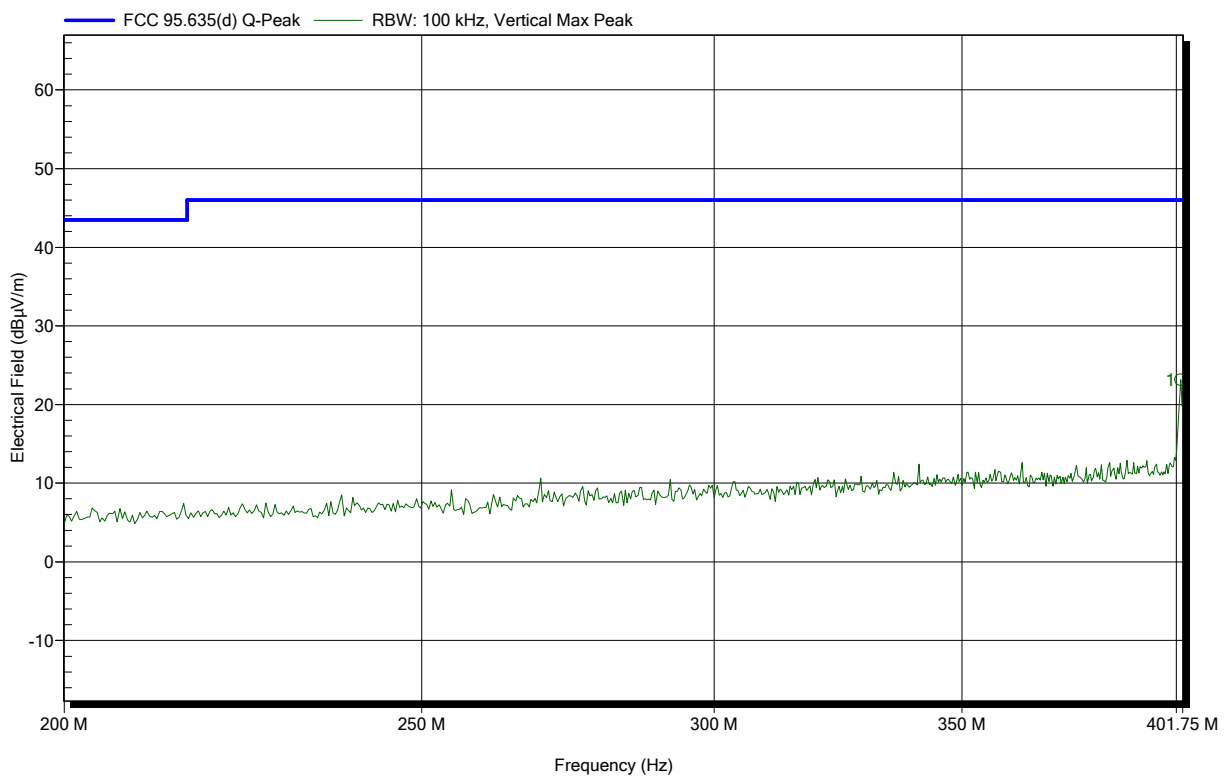

Frequency	Peak	Peak Limit	Peak Difference	Status
401.103 MHz	23.18 dBµV/m	46 dBµV/m	-22.82 dB	Pass

Spurious emissions according to FCC part 95 MedRadio (402-405MHz)

Project number: G0M-1908-8377

Applicant: BIOTRONIK SE & Co. KG
 EUT Name: CardioMessenger Smart / Telemonitoring System
 Model: CardioMessenger Smart 4G
 Test Site: Eurofins Product Service GmbH
 Operator: Wilfried Treffke
 Test Conditions: Tnom: 22°C, Vnom: 120 VAC (5V AC/DC adaptor)
 Antenna: Rohde & Schwarz HL 223, Horizontal
 Measurement distance: 3 m
 Mode: TX; 2-FSK; 404.85 MHz
 Test Date: 2019-09-23
 Note:

Index 12

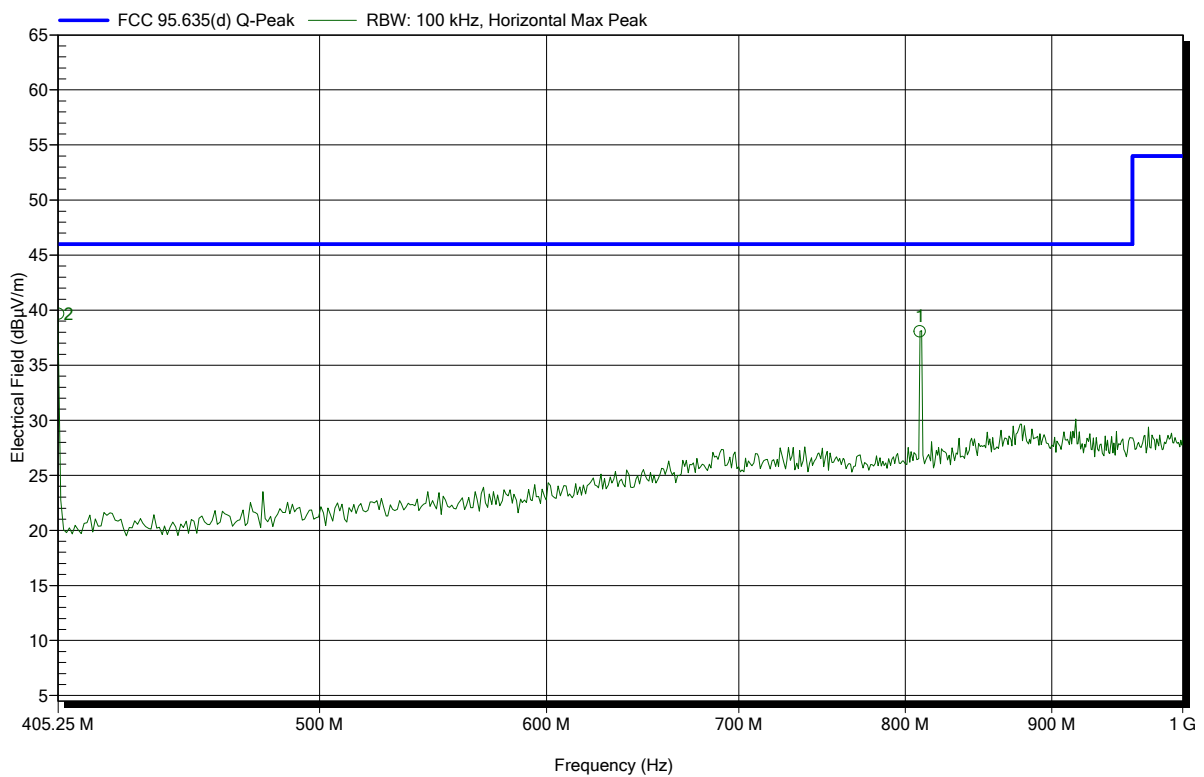

Frequency	Peak	Peak Limit	Peak Difference	Peak Status
405.25 MHz	39.69 dBµV/m	46 dBµV/m	-6.31 dB	Pass
809.375 MHz	38.07 dBµV/m	46 dBµV/m	-7.93 dB	Pass

Spurious emissions according to FCC part 95 MedRadio (402-405MHz)

Project number: G0M-1908-8377

Applicant: BIOTRONIK SE & Co. KG
 EUT Name: CardioMessenger Smart / Telemonitoring System
 Model: CardioMessenger Smart 4G
 Test Site: Eurofins Product Service GmbH
 Operator: Wilfried Treffke
 Test Conditions: Tnom: 22°C, Vnom: 120 VAC (5V AC/DC adaptor)
 Antenna: Rohde & Schwarz HL 223, Vertical
 Measurement distance: 3 m
 Mode: TX; 2-FSK; 404.85 MHz
 Test Date: 2019-09-23
 Note:

Index 16

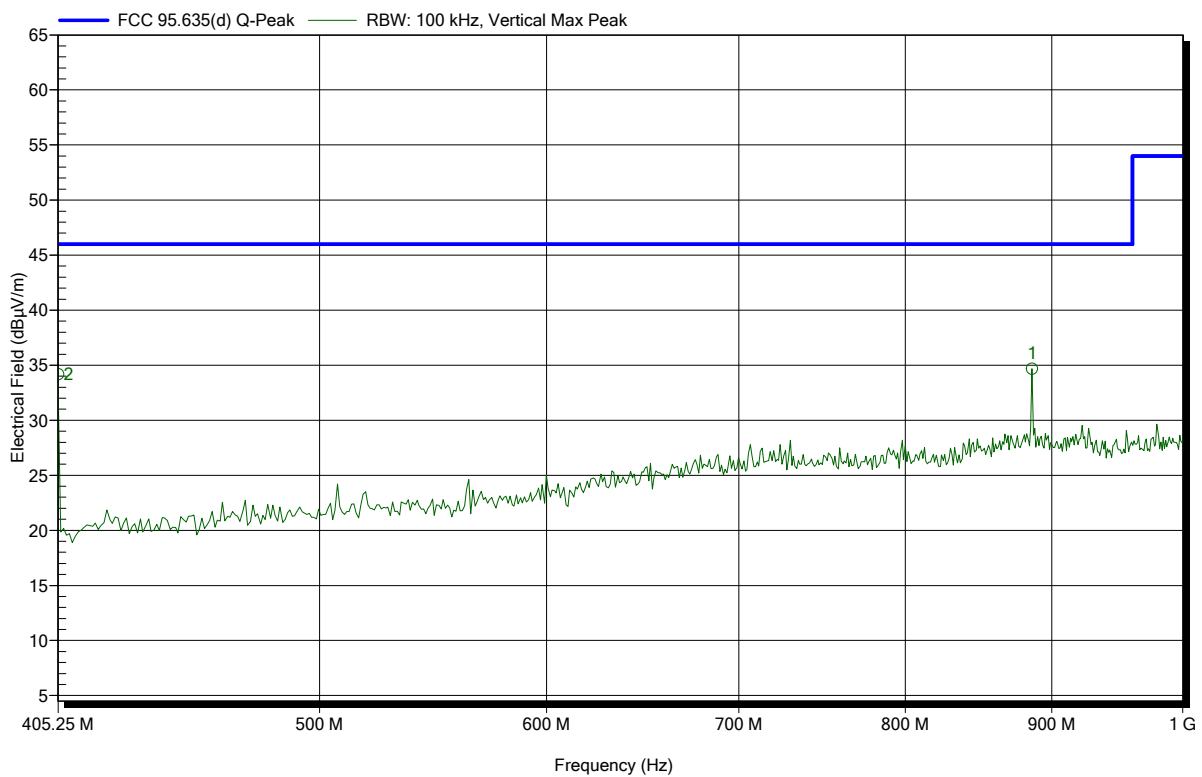

Frequency	Peak	Peak Limit	Peak Difference	Peak Status
405.25 MHz	34.18 dBµV/m	46 dBµV/m	-11.82 dB	Pass
885.625 MHz	34.67 dBµV/m	46 dBµV/m	-11.33 dB	Pass

Spurious emissions according to FCC part 95 MedRadio (402-405MHz)

Project number: G0M-1908-8377

Applicant: BIOTRONIK SE & Co. KG
 EUT Name: CardioMessenger Smart / Telemonitoring System
 Model: CardioMessenger Smart 4G
 Test Site: Eurofins Product Service GmbH
 Operator: Wilfried Treffke
 Test Conditions: Tnom: 22°C, Vnom: 120 VAC (5V AC/DC adaptor)
 Antenna: Schwarzbeck BBHA 9120D, Horizontal
 Measurement distance: 3 m
 Mode: TX; 2-FSK; 404.85 MHz
 Test Date: 2019-09-23
 Note:

Index 17

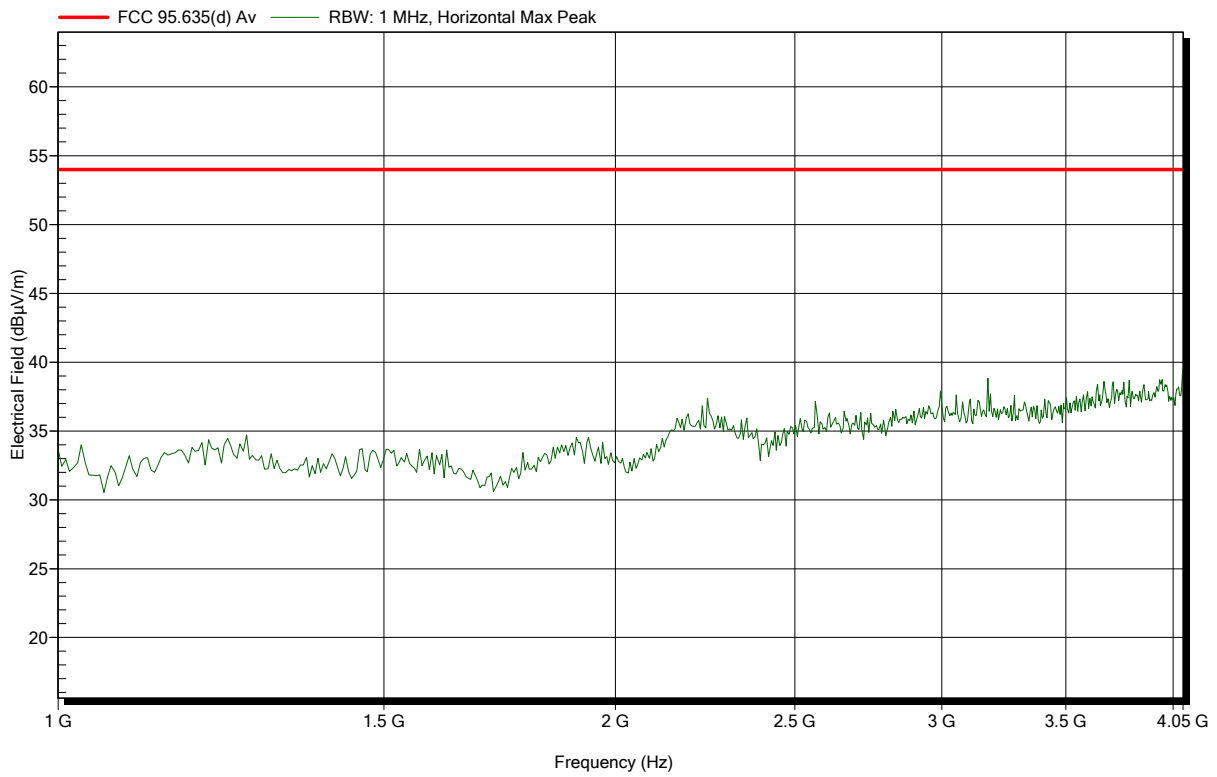

Spurious emissions according to FCC part 95 MedRadio (402-405MHz)

Project number: G0M-1908-8377

Applicant: BIOTRONIK SE & Co. KG
 EUT Name: CardioMessenger Smart / Telemonitoring System
 Model: CardioMessenger Smart 4G
 Test Site: Eurofins Product Service GmbH
 Operator: Wilfried Treffke
 Test Conditions: Tnom: 22°C, Vnom: 120 VAC (5V AC/DC adaptor)
 Antenna: Schwarzbeck BBHA 9120D, Vertical
 Measurement distance: 3 m
 Mode: TX; 2-FSK; 404.85 MHz
 Test Date: 2019-09-23
 Note:

Index 18

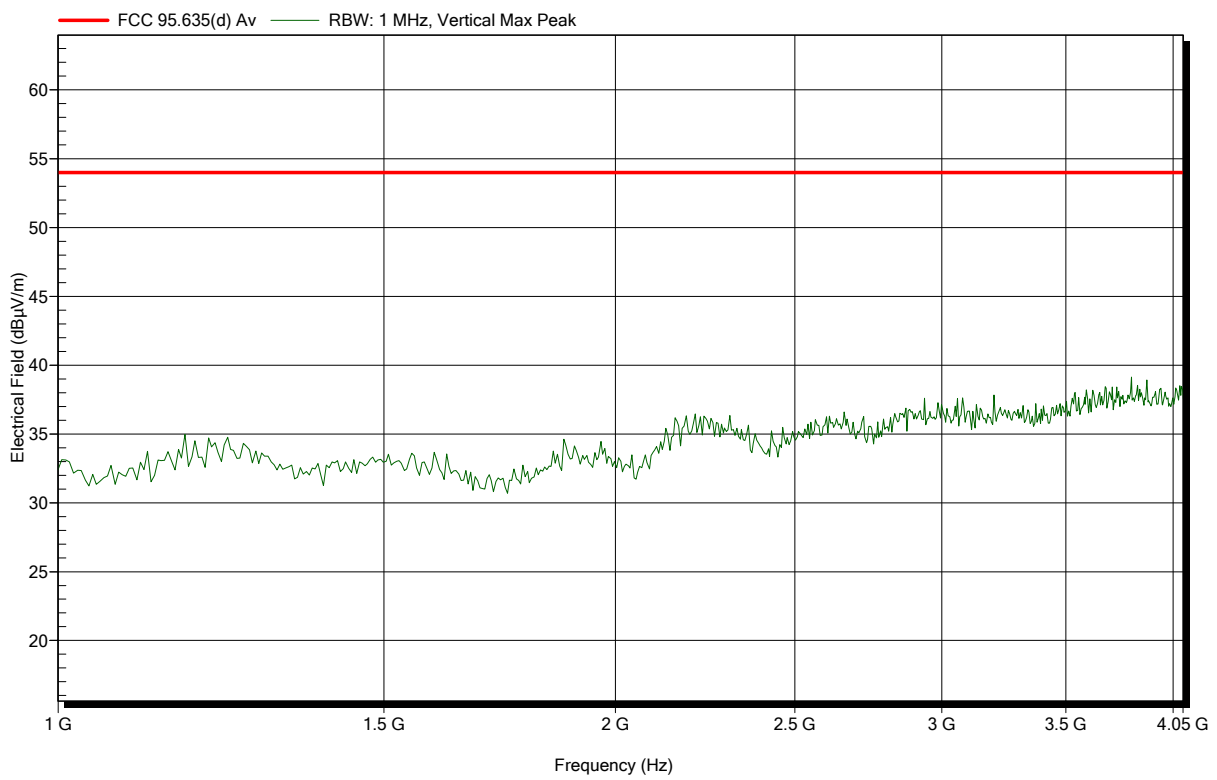

ANNEX E Receiver spurious emissions

Spurious emissions according to FCC part 95 MedRadio (402-405MHz)

Project number: G0M-1908-8377

Applicant: BIOTRONIK SE & Co. KG
 EUT Name: CardioMessenger Smart / Telemonitoring System
 Model: CardioMessenger Smart 4G
 Test Site: Eurofins Product Service GmbH
 Operator: Wilfried Treffke
 Test Conditions: Tnom: 22°C, Vnom: 120 VAC (5V AC/DC adaptor)
 Antenna: Rohde & Schwarz HK 116, Horizontal
 Measurement distance: 3 m
 Mode: RX; 403.65 MHz
 Test Date: 2019-09-23
 Note:

Index 33

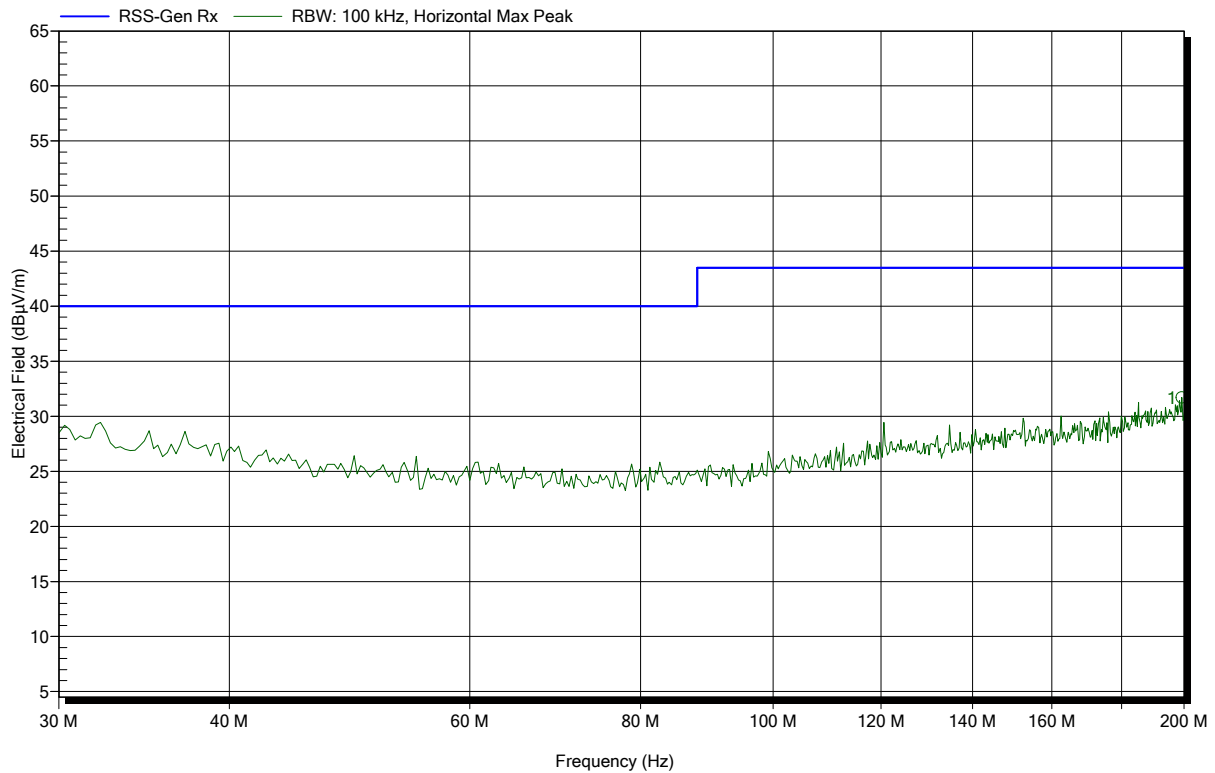

Frequency	Peak	Peak Limit	Peak Difference	Status
199.183 MHz	31.71 dBµV/m	43.5 dBµV/m	-11.79 dB	Pass

Spurious emissions according to FCC part 95 MedRadio (402-405MHz)

Project number: G0M-1908-8377

Applicant: BIOTRONIK SE & Co. KG
 EUT Name: CardioMessenger Smart / Telemonitoring System
 Model: CardioMessenger Smart 4G
 Test Site: Eurofins Product Service GmbH
 Operator: Wilfried Treffke
 Test Conditions: Tnom: 22°C, Vnom: 120 VAC (5V AC/DC adaptor)
 Antenna: Rohde & Schwarz HK 116, Vertical
 Measurement distance: 3 m
 Mode: RX; 403.65 MHz
 Test Date: 2019-09-23
 Note:

Index 34

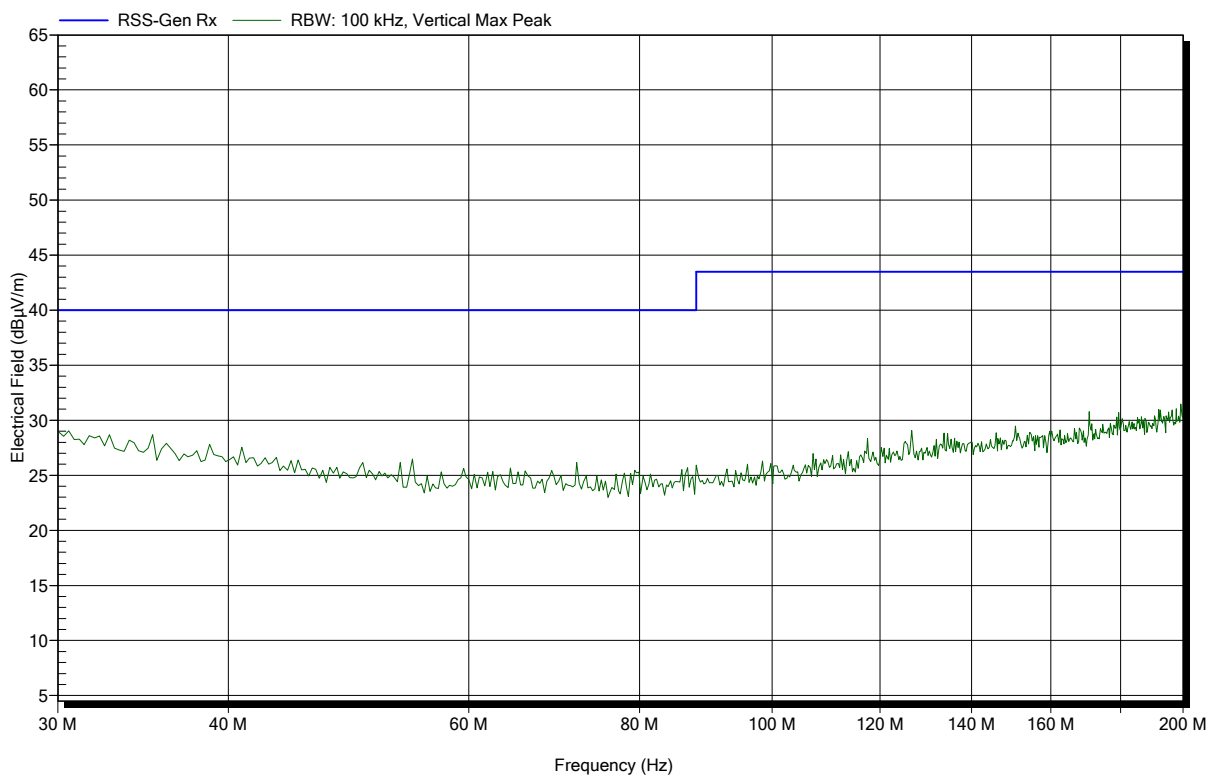

Spurious emissions according to FCC part 95 MedRadio (402-405MHz)

Project number: G0M-1908-8377

Applicant: BIOTRONIK SE & Co. KG
 EUT Name: CardioMessenger Smart / Telemonitoring System
 Model: CardioMessenger Smart 4G
 Test Site: Eurofins Product Service GmbH
 Operator: Wilfried Treffke
 Test Conditions: Tnom: 22°C, Vnom: 120 VAC (5V AC/DC adaptor)
 Antenna: Rohde & Schwarz HL 223, Horizontal
 Measurement distance: 3 m
 Mode: RX; 403.65 MHz
 Test Date: 2019-09-23
 Note:

Index 35

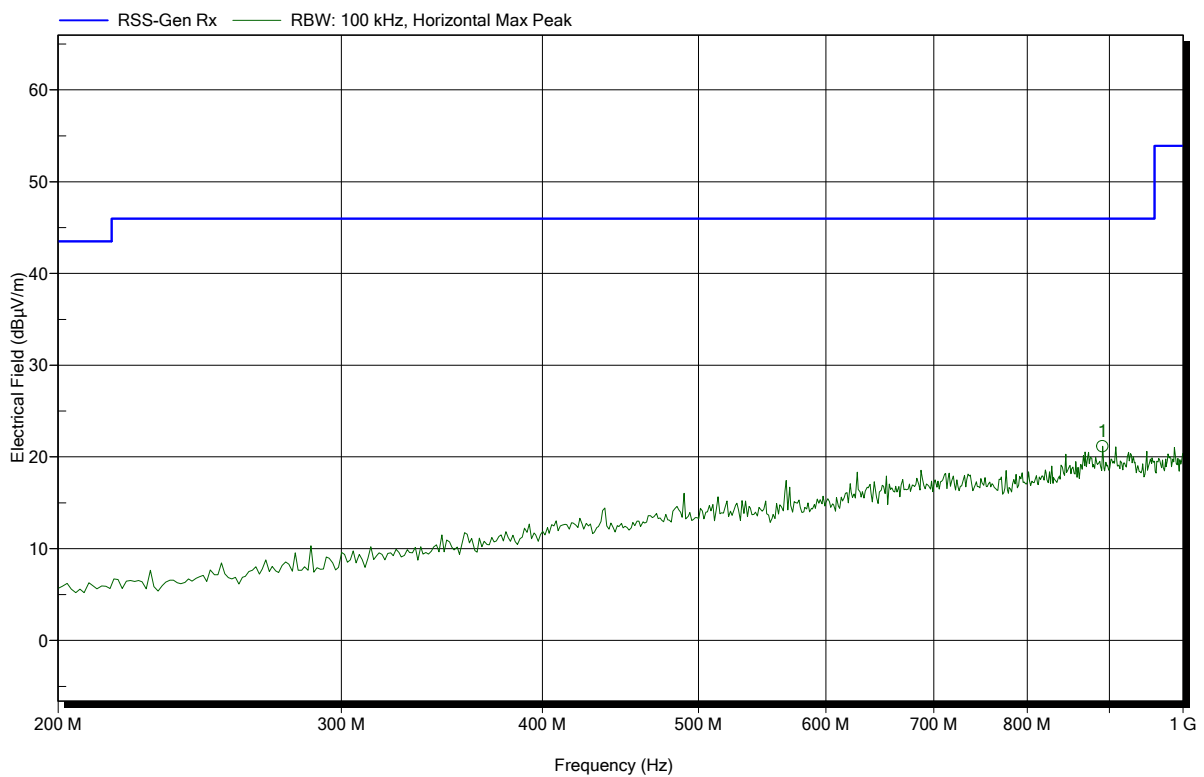

Frequency	Peak	Peak Limit	Peak Difference	Status
891.026 MHz	21.17 dBµV/m	46 dBµV/m	-24.83 dB	Pass

Spurious emissions according to FCC part 95 MedRadio (402-405MHz)

Project number: G0M-1908-8377

Applicant: BIOTRONIK SE & Co. KG
 EUT Name: CardioMessenger Smart / Telemonitoring System
 Model: CardioMessenger Smart 4G
 Test Site: Eurofins Product Service GmbH
 Operator: Wilfried Treffke
 Test Conditions: Tnom: 22°C, Vnom: 120 VAC (5V AC/DC adaptor)
 Antenna: Rohde & Schwarz HL 223, Vertical
 Measurement distance: 3 m
 Mode: RX; 403.65 MHz
 Test Date: 2019-09-23
 Note:

Index 36

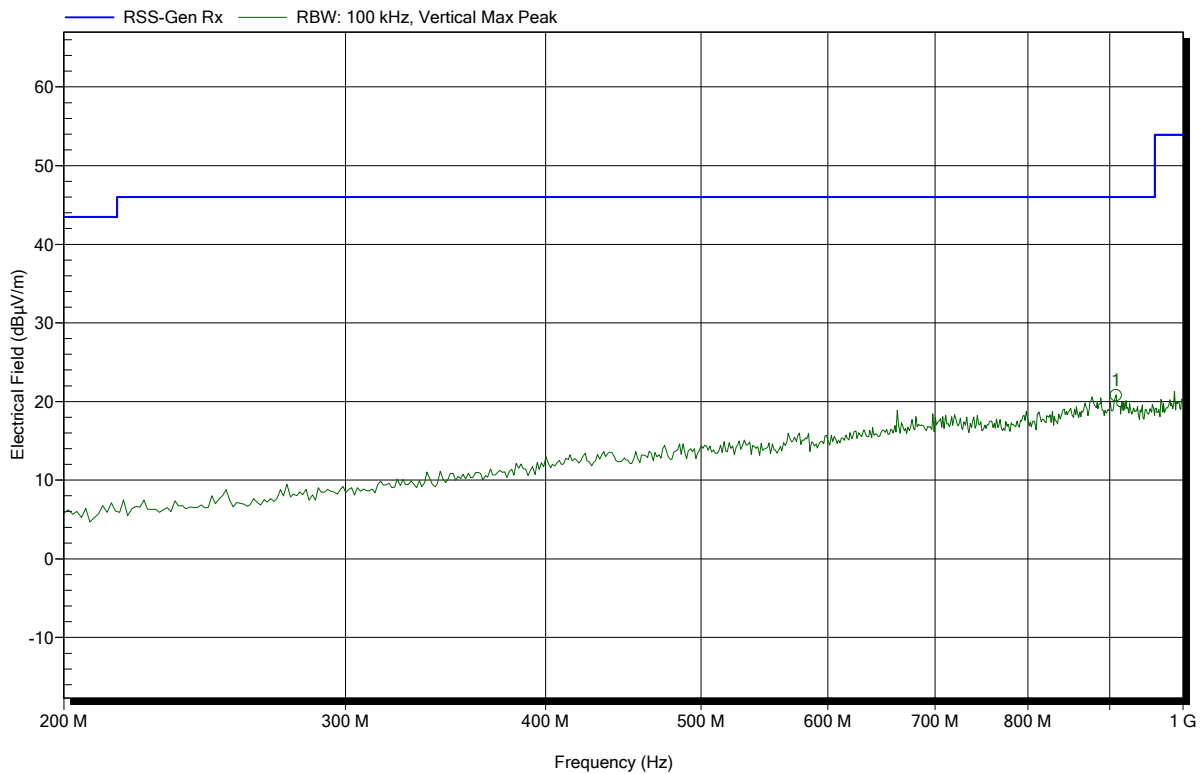

Frequency	Peak	Peak Limit	Peak Difference	Status
907.692 MHz	20.81 dBµV/m	46 dBµV/m	-25.19 dB	Pass

Spurious emissions according to FCC part 95 MedRadio (402-405MHz)

Project number: G0M-1908-8377

Applicant: BIOTRONIK SE & Co. KG
 EUT Name: CardioMessenger Smart / Telemonitoring System
 Model: CardioMessenger Smart 4G
 Test Site: Eurofins Product Service GmbH
 Operator: Wilfried Treffke
 Test Conditions: Tnom: 22°C, Vnom: 120 VAC (5V AC/DC adaptor)
 Antenna: Schwarzbeck BBHA 9120D, Horizontal
 Measurement distance: 3 m
 Mode: RX; 403.65 MHz
 Test Date: 2019-09-23
 Note:

Index 37

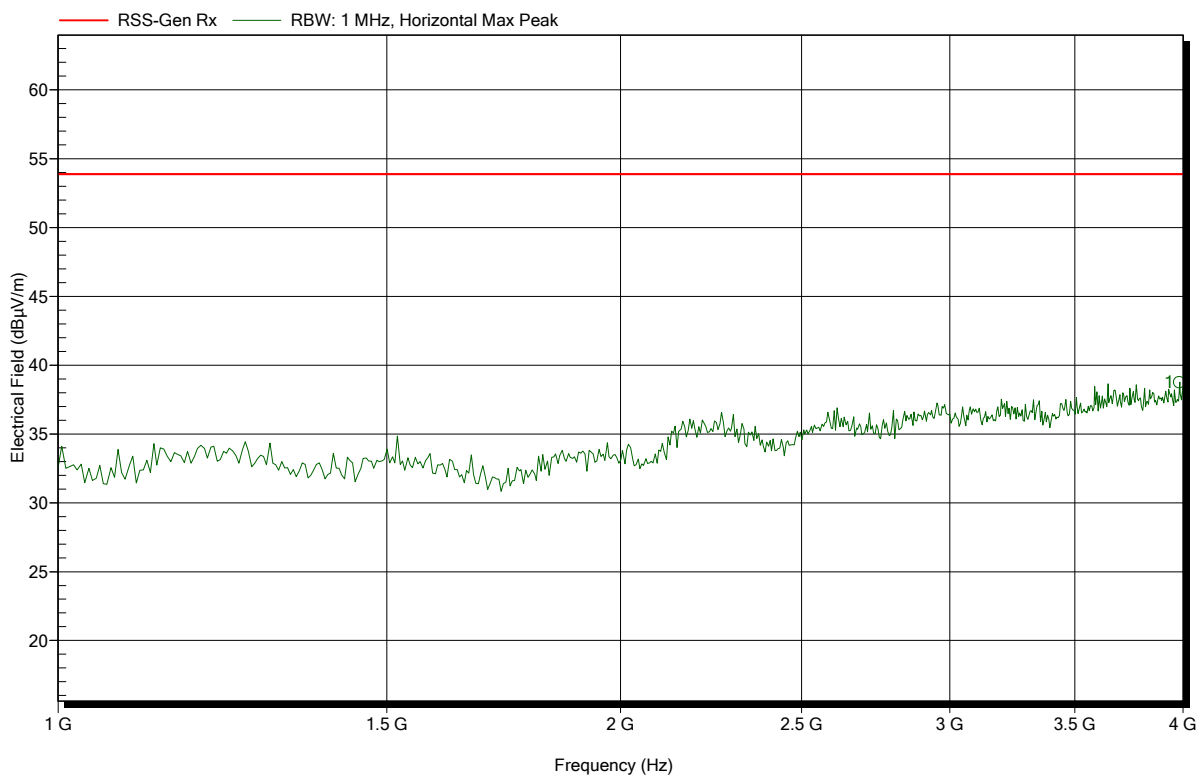

Frequency	Peak	Peak Limit	Peak Difference	Status
3.981 GHz	38.77 dBµV/m	53.9 dBµV/m	-15.13 dB	Pass

Spurious emissions according to FCC part 95 MedRadio (402-405MHz)

Project number: G0M-1908-8377

Applicant: BIOTRONIK SE & Co. KG
 EUT Name: CardioMessenger Smart / Telemonitoring System
 Model: CardioMessenger Smart 4G
 Test Site: Eurofins Product Service GmbH
 Operator: Wilfried Treffke
 Test Conditions: Tnom: 22°C, Vnom: 120 VAC (5V AC/DC adaptor)
 Antenna: Schwarzbeck BBHA 9120D, Vertical
 Measurement distance: 3 m
 Mode: RX; 403.65 MHz
 Test Date: 2019-09-23
 Note:

Index 38

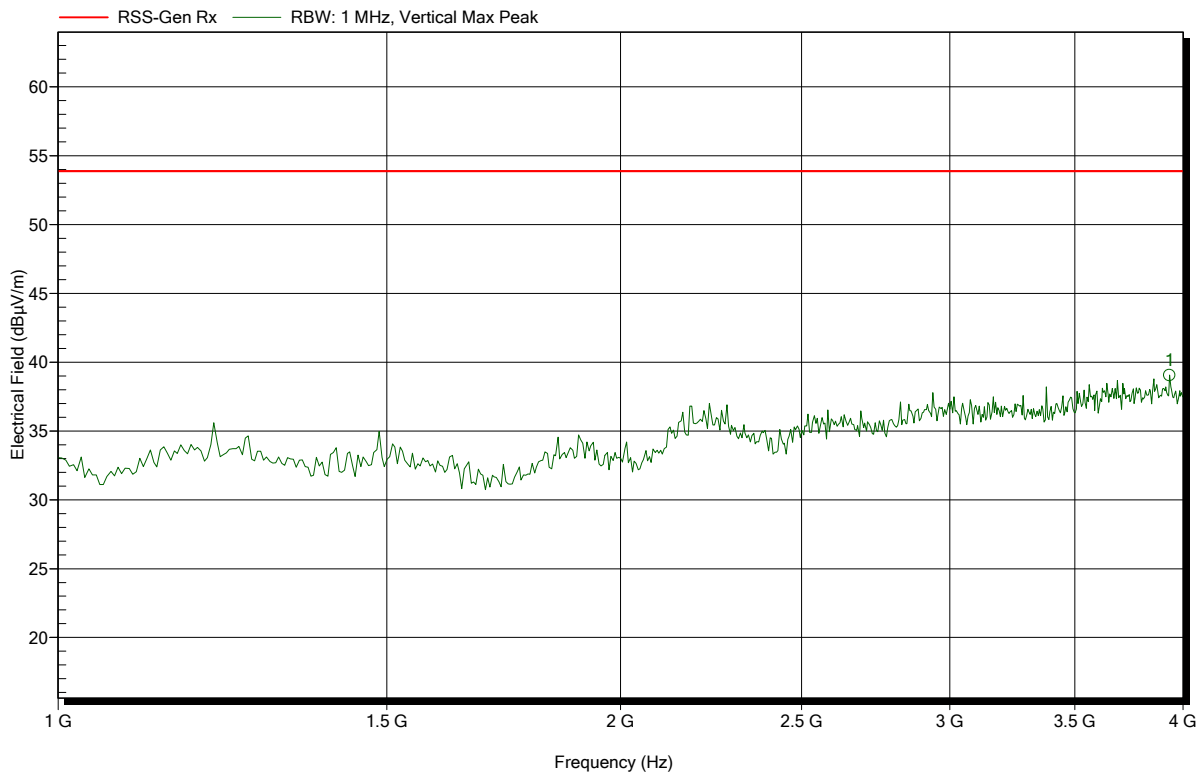

Frequency	Peak	Peak Limit	Peak Difference	Status
3.933 GHz	39.06 dBµV/m	53.9 dBµV/m	-14.84 dB	Pass