



Accredited by the Swiss Accreditation Service (SAS)  
The Swiss Accreditation Service is one of the signatories to the EA  
Multilateral Agreement for the recognition of calibration certificates

Accreditation No.: **SCS 0108**

Client **Eurofins**

Certificate No: **D750V3-1125\_Sep17**

## CALIBRATION CERTIFICATE

Object **D750V3 - SN:1125**

Calibration procedure(s) **QA CAL-05.v9**  
**Calibration procedure for dipole validation kits above 700 MHz**

Calibration date: **September 21, 2017**

This calibration certificate documents the traceability to national standards, which realize the physical units of measurements (SI).  
The measurements and the uncertainties with confidence probability are given on the following pages and are part of the certificate.

All calibrations have been conducted in the closed laboratory facility: environment temperature ( $22 \pm 3$ )°C and humidity < 70%.

Calibration Equipment used (M&TE critical for calibration)

Primary Standards	ID #	Cal Date (Certificate No.)	Scheduled Calibration
Power meter NRP	SN: 104778	04-Apr-17 (No. 217-02521/02522)	Apr-18
Power sensor NRP-Z91	SN: 103244	04-Apr-17 (No. 217-02521)	Apr-18
Power sensor NRP-Z91	SN: 103245	04-Apr-17 (No. 217-02522)	Apr-18
Reference 20 dB Attenuator	SN: 5058 (20k)	07-Apr-17 (No. 217-02528)	Apr-18
Type-N mismatch combination	SN: 5047.2 / 06327	07-Apr-17 (No. 217-02529)	Apr-18
Reference Probe EX3DV4	SN: 7349	31-May-17 (No. EX3-7349_May17)	May-18
DAE4	SN: 601	28-Mar-17 (No. DAE4-601_Mar17)	Mar-18
Secondary Standards	ID #	Check Date (in house)	Scheduled Check
Power meter EPM-442A	SN: GB37480704	07-Oct-15 (in house check Oct-16)	In house check: Oct-18
Power sensor HP 8481A	SN: US37292783	07-Oct-15 (in house check Oct-16)	In house check: Oct-18
Power sensor HP 8481A	SN: MY41092317	07-Oct-15 (in house check Oct-16)	In house check: Oct-18
RF generator R&S SMT-06	SN: 100972	15-Jun-15 (in house check Oct-16)	In house check: Oct-18
Network Analyzer HP 8753E	SN: US37390585	18-Oct-01 (in house check Oct-16)	In house check: Oct-17

Calibrated by: **Michael Weber**      Name: **Michael Weber**      Function: **Laboratory Technician**

Approved by: **Katja Pokovic**      Name: **Katja Pokovic**      Function: **Technical Manager**

Signature

Issued: September 21, 2017

This calibration certificate shall not be reproduced except in full without written approval of the laboratory.





Accredited by the Swiss Accreditation Service (SAS)  
The Swiss Accreditation Service is one of the signatories to the EA  
Multilateral Agreement for the recognition of calibration certificates

Accreditation No.: **SCS 0108**

**Glossary:**

TSL	tissue simulating liquid
ConvF	sensitivity in TSL / NORM x,y,z
N/A	not applicable or not measured

**Calibration is Performed According to the Following Standards:**

- a) IEEE Std 1528-2013, "IEEE Recommended Practice for Determining the Peak Spatial-Averaged Specific Absorption Rate (SAR) in the Human Head from Wireless Communications Devices: Measurement Techniques", June 2013
- b) IEC 62209-1, "Measurement procedure for the assessment of Specific Absorption Rate (SAR) from hand-held and body-mounted devices used next to the ear (frequency range of 300 MHz to 6 GHz)", July 2016
- c) IEC 62209-2, "Procedure to determine the Specific Absorption Rate (SAR) for wireless communication devices used in close proximity to the human body (frequency range of 30 MHz to 6 GHz)", March 2010
- d) KDB 865664, "SAR Measurement Requirements for 100 MHz to 6 GHz"

**Additional Documentation:**

- e) DASY4/5 System Handbook

**Methods Applied and Interpretation of Parameters:**

- *Measurement Conditions:* Further details are available from the Validation Report at the end of the certificate. All figures stated in the certificate are valid at the frequency indicated.
- *Antenna Parameters with TSL:* The dipole is mounted with the spacer to position its feed point exactly below the center marking of the flat phantom section, with the arms oriented parallel to the body axis.
- *Feed Point Impedance and Return Loss:* These parameters are measured with the dipole positioned under the liquid filled phantom. The impedance stated is transformed from the measurement at the SMA connector to the feed point. The Return Loss ensures low reflected power. No uncertainty required.
- *Electrical Delay:* One-way delay between the SMA connector and the antenna feed point. No uncertainty required.
- *SAR measured:* SAR measured at the stated antenna input power.
- *SAR normalized:* SAR as measured, normalized to an input power of 1 W at the antenna connector.
- *SAR for nominal TSL parameters:* The measured TSL parameters are used to calculate the nominal SAR result.

The reported uncertainty of measurement is stated as the standard uncertainty of measurement multiplied by the coverage factor  $k=2$ , which for a normal distribution corresponds to a coverage probability of approximately 95%.

## Measurement Conditions

DASY system configuration, as far as not given on page 1.

<b>DASY Version</b>	DASY5	V52.10.0
<b>Extrapolation</b>	Advanced Extrapolation	
<b>Phantom</b>	Modular Flat Phantom	
<b>Distance Dipole Center - TSL</b>	15 mm	with Spacer
<b>Zoom Scan Resolution</b>	dx, dy, dz = 5 mm	
<b>Frequency</b>	750 MHz $\pm$ 1 MHz	

## Head TSL parameters

The following parameters and calculations were applied.

	Temperature	Permittivity	Conductivity
<b>Nominal Head TSL parameters</b>	22.0 °C	41.9	0.89 mho/m
<b>Measured Head TSL parameters</b>	(22.0 $\pm$ 0.2) °C	41.2 $\pm$ 6 %	0.90 mho/m $\pm$ 6 %
<b>Head TSL temperature change during test</b>	< 0.5 °C	----	----

## SAR result with Head TSL

<b>SAR averaged over 1 cm<sup>3</sup> (1 g) of Head TSL</b>	Condition	
SAR measured	250 mW input power	2.08 W/kg
SAR for nominal Head TSL parameters	normalized to 1W	<b>8.22 W/kg <math>\pm</math> 17.0 % (k=2)</b>

<b>SAR averaged over 10 cm<sup>3</sup> (10 g) of Head TSL</b>	condition	
SAR measured	250 mW input power	1.35 W/kg
SAR for nominal Head TSL parameters	normalized to 1W	<b>5.35 W/kg <math>\pm</math> 16.5 % (k=2)</b>

## Body TSL parameters

The following parameters and calculations were applied.

	Temperature	Permittivity	Conductivity
<b>Nominal Body TSL parameters</b>	22.0 °C	55.5	0.96 mho/m
<b>Measured Body TSL parameters</b>	(22.0 $\pm$ 0.2) °C	55.5 $\pm$ 6 %	0.96 mho/m $\pm$ 6 %
<b>Body TSL temperature change during test</b>	< 0.5 °C	----	----

## SAR result with Body TSL

<b>SAR averaged over 1 cm<sup>3</sup> (1 g) of Body TSL</b>	Condition	
SAR measured	250 mW input power	2.13 W/kg
SAR for nominal Body TSL parameters	normalized to 1W	<b>8.52 W/kg <math>\pm</math> 17.0 % (k=2)</b>

<b>SAR averaged over 10 cm<sup>3</sup> (10 g) of Body TSL</b>	condition	
SAR measured	250 mW input power	1.41 W/kg
SAR for nominal Body TSL parameters	normalized to 1W	<b>5.64 W/kg <math>\pm</math> 16.5 % (k=2)</b>

## Appendix (Additional assessments outside the scope of SCS 0108)

### Antenna Parameters with Head TSL

Impedance, transformed to feed point	55.6 $\Omega$ - 0.7 j $\Omega$
Return Loss	- 25.5 dB

### Antenna Parameters with Body TSL

Impedance, transformed to feed point	50.0 $\Omega$ - 5.0 j $\Omega$
Return Loss	- 26.1 dB

### General Antenna Parameters and Design

Electrical Delay (one direction)	1.033 ns
----------------------------------	----------

After long term use with 100W radiated power, only a slight warming of the dipole near the feedpoint can be measured.

The dipole is made of standard semirigid coaxial cable. The center conductor of the feeding line is directly connected to the second arm of the dipole. The antenna is therefore short-circuited for DC-signals. On some of the dipoles, small end caps are added to the dipole arms in order to improve matching when loaded according to the position as explained in the "Measurement Conditions" paragraph. The SAR data are not affected by this change. The overall dipole length is still according to the Standard.

No excessive force must be applied to the dipole arms, because they might bend or the soldered connections near the feedpoint may be damaged.

### Additional EUT Data

Manufactured by	SPEAG
Manufactured on	June 23, 2014



## DASY5 Validation Report for Head TSL

Date: 21.09.2017

Test Laboratory: SPEAG, Zurich, Switzerland

**DUT: Dipole 750 MHz; Type: D750V3; Serial: D750V3 - SN:1125**

Communication System: UID 0 - CW; Frequency: 750 MHz

Medium parameters used:  $f = 750$  MHz;  $\sigma = 0.9$  S/m;  $\epsilon_r = 41.2$ ;  $\rho = 1000$  kg/m<sup>3</sup>

Phantom section: Flat Section

Measurement Standard: DASY5 (IEEE/IEC/ANSI C63.19-2011)

DASY52 Configuration:

- Probe: EX3DV4 - SN7349; ConvF(10.49, 10.49, 10.49); Calibrated: 31.05.2017;
- Sensor-Surface: 1.4mm (Mechanical Surface Detection)
- Electronics: DAE4 Sn601; Calibrated: 28.03.2017
- Phantom: Flat Phantom 4.9 (front); Type: QD 00L P49 AA; Serial: 1001
- DASY52 52.10.0(1446); SEMCAD X 14.6.10(7417)

### Dipole Calibration for Head Tissue/Pin=250 mW, d=15mm/Zoom Scan (7x7x7)/Cube 0:

Measurement grid: dx=5mm, dy=5mm, dz=5mm

Reference Value = 58.66 V/m; Power Drift = 0.01 dB

Peak SAR (extrapolated) = 3.22 W/kg

**SAR(1 g) = 2.08 W/kg; SAR(10 g) = 1.35 W/kg**

Maximum value of SAR (measured) = 2.82 W/kg

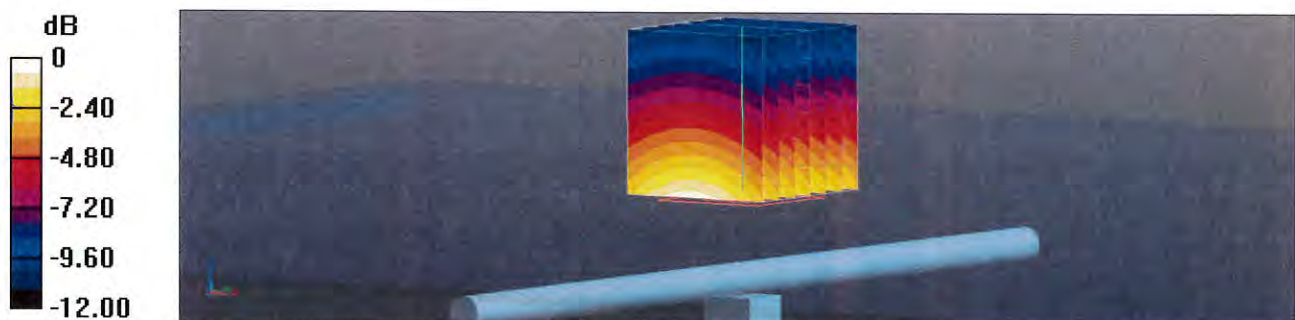

0 dB = 2.82 W/kg = 4.50 dBW/kg

# Impedance Measurement Plot for Head TSL

21 Sep 2017 12:00:11  
 [CH1] S11 1 U FS 1: 55.570  $\Omega$  -689.45 m $\Omega$  307.79 pF 750.000 000 MHz

\*  
 De1  
 CA

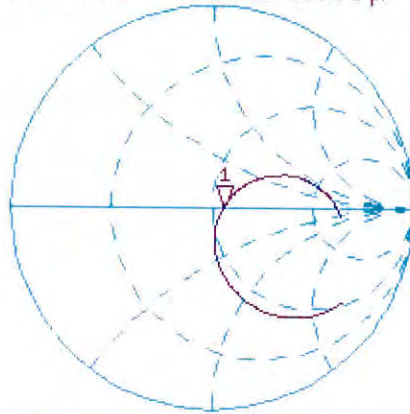

Avg  
 16

H1d

CH2 S11 LOG 5 dB/REF -20 dB 1:-25.481 dB 750.000 000 MHz

CA

Avg  
 16

H1d

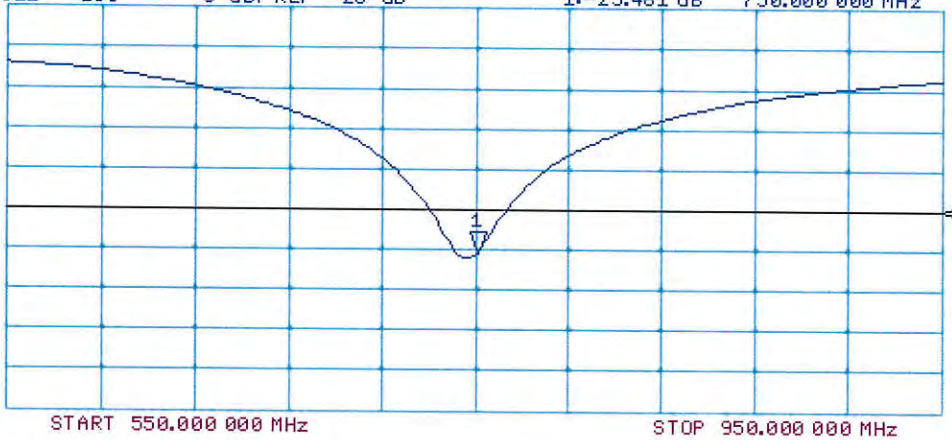

## DASY5 Validation Report for Body TSL

Date: 21.09.2017

Test Laboratory: SPEAG, Zurich, Switzerland

**DUT: Dipole 750 MHz; Type: D750V3; Serial: D750V3 - SN:1125**

Communication System: UID 0 - CW; Frequency: 750 MHz

Medium parameters used:  $f = 750$  MHz;  $\sigma = 0.96$  S/m;  $\epsilon_r = 55.5$ ;  $\rho = 1000$  kg/m<sup>3</sup>

Phantom section: Flat Section

Measurement Standard: DASY5 (IEEE/IEC/ANSI C63.19-2011)

DASY52 Configuration:

- Probe: EX3DV4 - SN7349; ConvF(10.35, 10.35, 10.35); Calibrated: 31.05.2017;
- Sensor-Surface: 1.4mm (Mechanical Surface Detection)
- Electronics: DAE4 Sn601; Calibrated: 28.03.2017
- Phantom: Flat Phantom 4.9 (Back); Type: QD 00R P49 AA; Serial: 1005
- DASY52 52.10.0(1446); SEMCAD X 14.6.10(7417)

### Dipole Calibration for Body Tissue/Pin=250 mW, d=15mm/Zoom Scan (7x7x7)/Cube 0:

Measurement grid: dx=5mm, dy=5mm, dz=5mm

Reference Value = 57.01 V/m; Power Drift = 0.01 dB

Peak SAR (extrapolated) = 3.17 W/kg

**SAR(1 g) = 2.13 W/kg; SAR(10 g) = 1.41 W/kg**

Maximum value of SAR (measured) = 2.81 W/kg

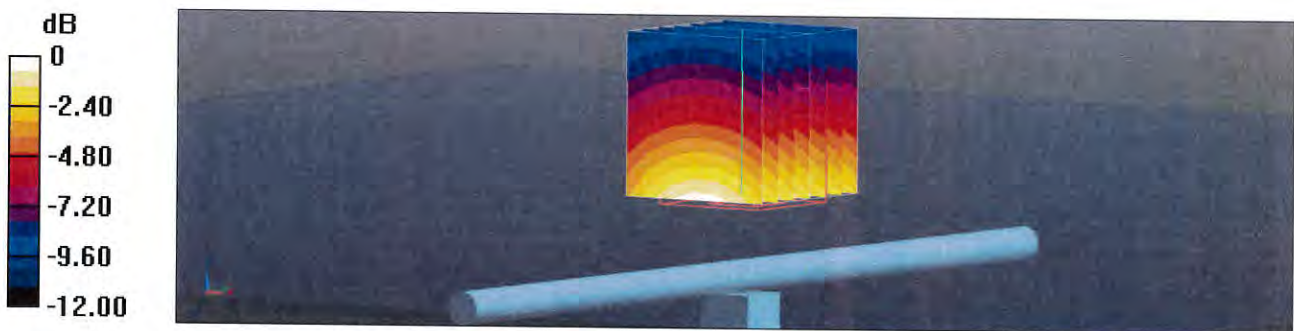

0 dB = 2.81 W/kg = 4.49 dBW/kg



# Impedance Measurement Plot for Body TSL

21 Sep 2017 11:59:36  
 [CH1] S11 1 U FS 1: 50.037  $\Omega$  -4.9746  $\Omega$  42.658 pF 750.000 000 MHz

\*  
 De l  
 CA  
 Avg  
 16  
 H1 d

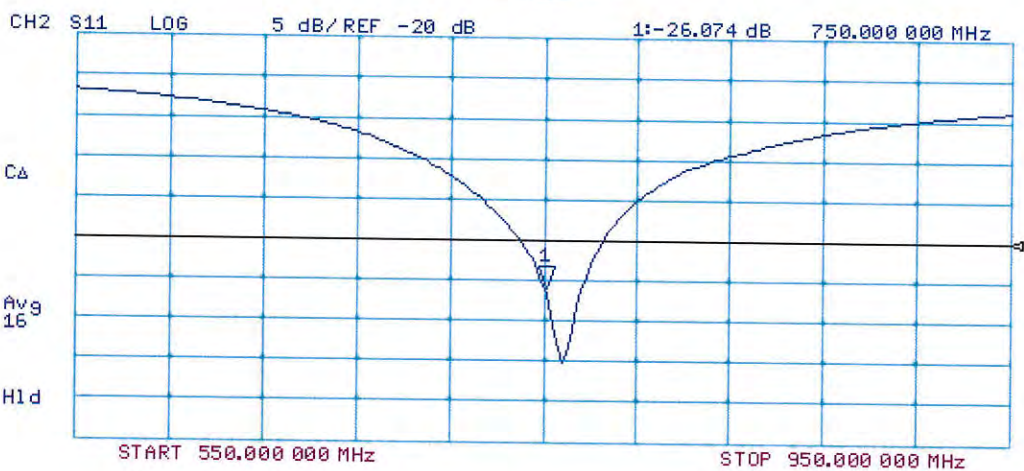
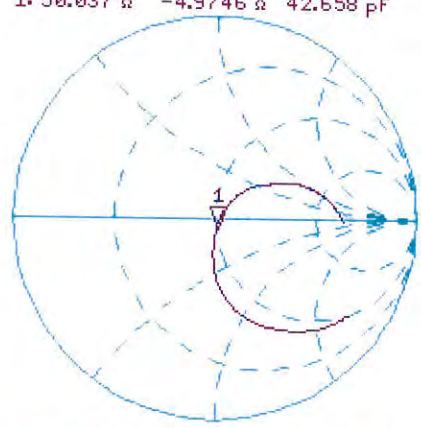



# Validation Report

## No. VAL\_0946\_EF 2019-03

Kind of doc.:  
QM Template

**EUROFINS PRODUCT SERVICE GmbH**  
Storkower Str. 38c, 15526 Reichenwalde, Germany

### 1 Customer

Eurofins Product Service GmbH

### 2 Object

Equipment Number: EF00946  
 Equipment Name: System validation dipole  
 Equipment Type: D750V3  
 Serial Number: 1125  
 Manufacturer: Schmid & Partner Engineering AG

### 3 State of Measurement

Validation:   
 Performance Control:   
 Other:

### 4 Performance of Measurement

#### 4.1 Generals

(e.g. object of validation such as specific setup, non-standard method or SW, specification of the requirements, test set-up configuration, risk analysis etc.)

Dipol verification

#### 4.2 Validation procedure / measurement

(e.g. comparison of results achieved with other methods, interlaboratory comparison, systematic assessment of factors influencing the result, assessment of the uncertainty of the results based on scientific understanding of the theoretical principles of the method and practical experience; criteria/requirements for approval/rejection etc.)

According KDB 865664 D01 SAR Measurement 100 MHz to 6 GHz v01r04 3.2.2 Dipole calibration

Limits for the verification: return loss <20% to the original measurement or >20 dB minimum return-loss  
 Impedance <5 Ω to the original measurement.

#### 4.3 Used reference equipment

Equipment name	Equipment type	Manufacturer	Equipment number	Cal. Date	Cal. Due Date
RF Network analyzer	8752 C	Hewlett-Packard Company Santa Clara	EF00140	2018-07-25	2019-07-25

- new acquired (incl. calibration)
- new calibrated
- check reference standard

#### 4.4 Environmental conditions

Temperature:   23   °C ± 2°C  
 Relative Air Humidity:   50   rH ± 5%  
 Air Pressure:  1020  hPa ± 5%

# Validation Report

## No. VAL\_0946\_EF 2019-03

 Kind of doc.:  
QM Template

 EUROFINS PRODUCT SERVICE GmbH  
Storkower Str. 38c, 15526 Reichenwalde, Germany

**5 Results**
**5.1 General:**

(e.g. measurement results, user instructions such as handling, transport, storage, preparation; checks to be made before the work started; information about how to install (operations)-, to maintain-, to train and to use; safety measures etc.)

	Original measurement	Verification measurement	Margin
Impedance, transformend to feed point	50.0 $\Omega$ + 5.0 j $\Omega$	50.15 $\Omega$ + 3.38 j $\Omega$	0.15 $\Omega$ - 1.62 j $\Omega$
Return Loss	-26.1 dB	-29.72 dB	3.62 dB
Tissue Validation $\epsilon_r$	55.5	54.145	-2.44 %
Tissue Validation $\sigma$ [S/m]	0.96	0.986	2.71 %
System validation	8.52 W/kg (1g)	8.64W/kg (1g)	1.41 %
Date:	21.09.2017	13.03.2019	

**5.2 Measurement uncertainty**

The reported expanded uncertainty of measurement is stated as the standard uncertainty multiplied by the coverage factor k=2, which for a normal distribution corresponds to a coverage probability of approximately 95%.  
+/- 2.5 %

**5.3 Results of Validation**

Validated

Not validated

**6 Operator**

 Pudell  
Name

  
Signature

Place and Date of Verification: Reichenwalde, 14.03.2019

Attachment:

Impedance, Return Loss, System validierung





# Validation Report

## No. VAL\_0946\_EF 2019-03

 Kind of doc.:  
 QM Template

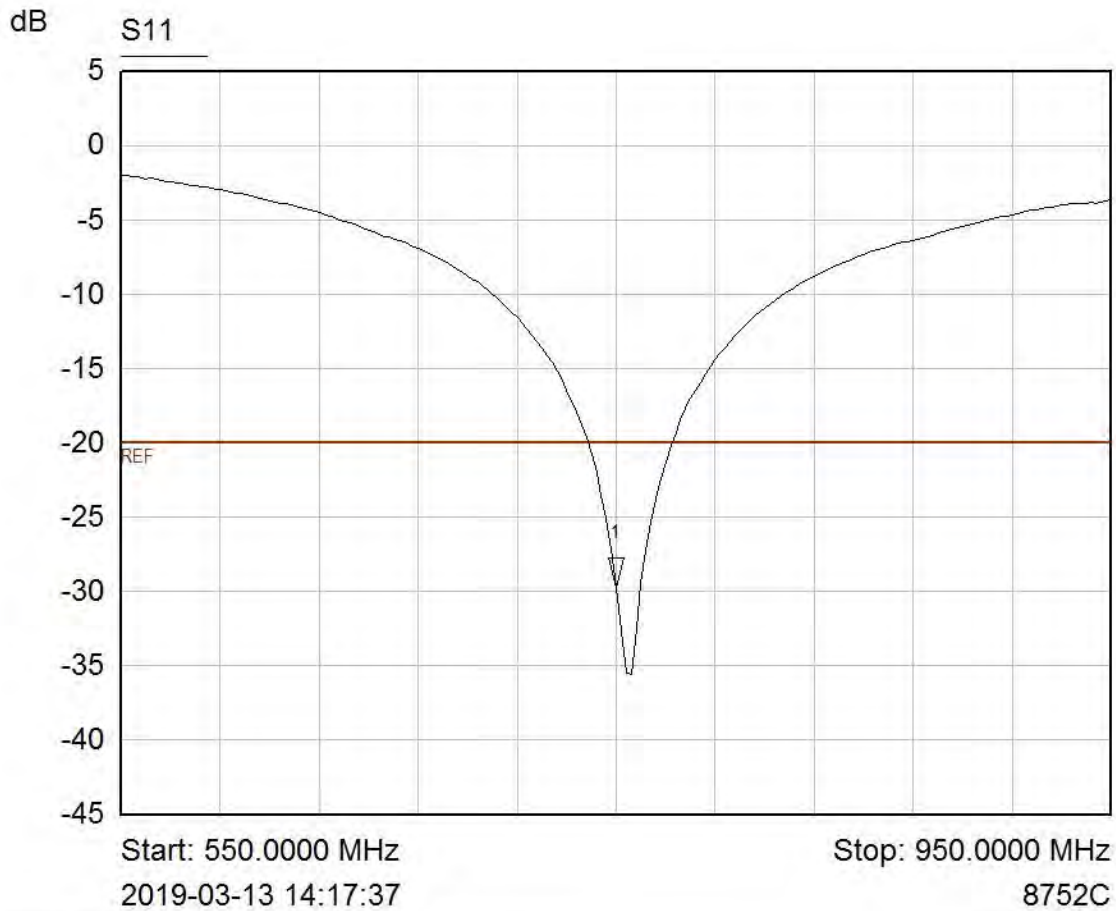
**EUROFINS PRODUCT SERVICE GmbH**  
 Storkower Str. 38c, 15526 Reichenwalde, Germany

Mkr	Trace	X-Axis	Value	Notes
1 ▾	S11	750.0000 MHz	-29.72 dB	

# Validation Report

## No. VAL\_0946\_EF 2019-03

Kind of doc.:  
QM Template

EUROFINS PRODUCT SERVICE GmbH  
Storkower Str. 38c, 15526 Reichenwalde, Germany

Date Time: 2019-03-14 08:09:07

### Test Laboratory: Eurofins Product Service GmbH

#### Dipol Valid.750 (m)\_250mW ELI4\_14.03.2019

DUT: Dipole 750 MHz; Type: D750V3; Serial: 1125

Communication System: UID 0 - n/a, CW; Frequency: 750 MHz; Duty Cycle: 1:1  
Medium: Muscle 750 MHz Medium parameters used:  $f = 750 \text{ MHz}$ ;  $\sigma = 0.986 \text{ S/m}$ ;  $\epsilon_r = 54.145$ ;  $\rho = 1000 \text{ kg/m}^3$   
Phantom section: Flat Section

Measurement Standard: DASYS (IEEE/IEC/ANSI C63.19-2007)

#### DASY5.2 Configuration:

- Probe: EX3DV4 - SN3893; ConvF(10.54, 10.54, 10.54); Calibrated: 2018-09-20;
- Sensor-Surface: 4mm (Mechanical Surface Detection)
- Electronics: DAE3 Sn522; Calibrated: 2018-09-17
- Phantom: Flat Phantom ELI4.0; Type: QDOVA001BB; Serial: SN:1013
- Measurement SW: DASY52, Version 52.8 (6); SEMCAD X Version 14.6.9 (7117)

**System Performance Check at Frequencies below 1 GHz/d=15mm, Pin=250 mW, dist=4.0mm (EX-Probe)/Area Scan (7x9x1):** Measurement grid: dx=15mm, dy=15mm  
Maximum value of SAR (measured) = 2.33 W/kg

**System Performance Check at Frequencies below 1 GHz/d=15mm, Pin=250 mW, dist=4.0mm (EX-Probe)/Zoom Scan (7x7x7) (7x7x7)/Cube 0:** Measurement grid: dx=5mm, dy=5mm, dz=5mm  
Reference Value = 52.966 V/m; Power Drift = 0.00 dB  
Peak SAR (extrapolated) = 3.17 W/kg  
SAR(1 g) = 2.16 W/kg; SAR(10 g) = 1.44 W/kg  
Maximum value of SAR (measured) = 2.72 W/kg

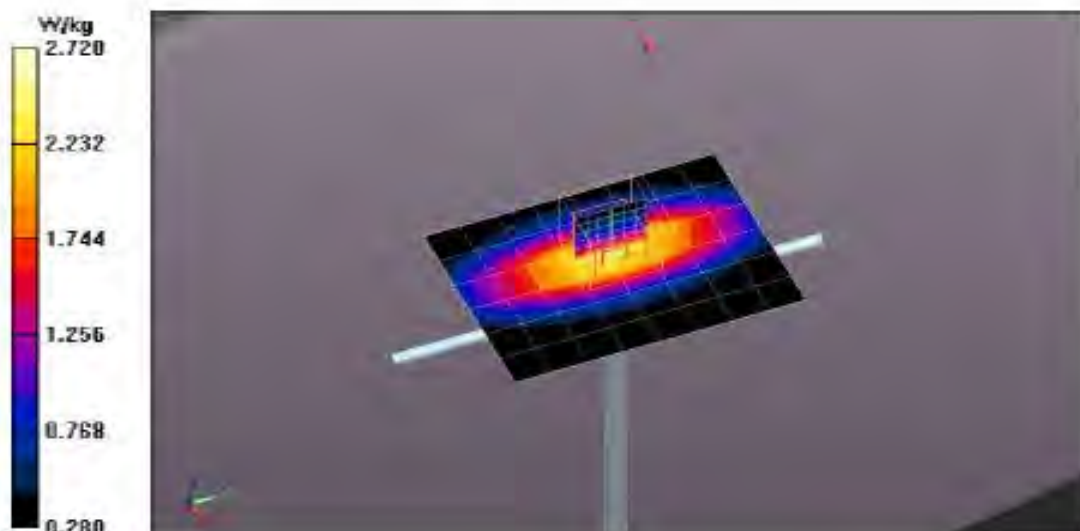



Accredited by the Swiss Accreditation Service (SAS)  
The Swiss Accreditation Service is one of the signatories to the EA  
Multilateral Agreement for the recognition of calibration certificates

Accreditation No.: **SCS 0108**

Client **Eurofins**

Certificate No: **D1750V2-1126\_Sep17**

## CALIBRATION CERTIFICATE

Object **D1750V2 - SN:1126**

Calibration procedure(s) **QA CAL-05.v9**  
**Calibration procedure for dipole validation kits above 700 MHz**

Calibration date: **September 20, 2017**

This calibration certificate documents the traceability to national standards, which realize the physical units of measurements (SI).  
The measurements and the uncertainties with confidence probability are given on the following pages and are part of the certificate.

All calibrations have been conducted in the closed laboratory facility: environment temperature ( $22 \pm 3$ )°C and humidity < 70%.

Calibration Equipment used (M&TE critical for calibration)

Primary Standards	ID #	Cal Date (Certificate No.)	Scheduled Calibration
Power meter NRP	SN: 104778	04-Apr-17 (No. 217-02521/02522)	Apr-18
Power sensor NRP-Z91	SN: 103244	04-Apr-17 (No. 217-02521)	Apr-18
Power sensor NRP-Z91	SN: 103245	04-Apr-17 (No. 217-02522)	Apr-18
Reference 20 dB Attenuator	SN: 5058 (20k)	07-Apr-17 (No. 217-02528)	Apr-18
Type-N mismatch combination	SN: 5047.2 / 06327	07-Apr-17 (No. 217-02529)	Apr-18
Reference Probe EX3DV4	SN: 7349	31-May-17 (No. EX3-7349_May17)	May-18
DAE4	SN: 601	28-Mar-17 (No. DAE4-601_Mar17)	Mar-18

Secondary Standards	ID #	Check Date (in house)	Scheduled Check
Power meter EPM-442A	SN: GB37480704	07-Oct-15 (in house check Oct-16)	In house check: Oct-18
Power sensor HP 8481A	SN: US37292783	07-Oct-15 (in house check Oct-16)	In house check: Oct-18
Power sensor HP 8481A	SN: MY41092317	07-Oct-15 (in house check Oct-16)	In house check: Oct-18
RF generator R&S SMT-06	SN: 100972	15-Jun-15 (in house check Oct-16)	In house check: Oct-18
Network Analyzer HP 8753E	SN: US37390585	18-Oct-01 (in house check Oct-16)	In house check: Oct-17

Calibrated by:	Name <b>Jeton Kastrati</b>	Function <b>Laboratory Technician</b>	Signature 
Approved by:	Name <b>Katja Pokovic</b>	Function <b>Technical Manager</b>	Signature 

Issued: September 20, 2017

This calibration certificate shall not be reproduced except in full without written approval of the laboratory.





Accredited by the Swiss Accreditation Service (SAS)

Accreditation No.: **SCS 0108**

The Swiss Accreditation Service is one of the signatories to the EA  
Multilateral Agreement for the recognition of calibration certificates

### Glossary:

TSL	tissue simulating liquid
ConvF	sensitivity in TSL / NORM x,y,z
N/A	not applicable or not measured

### Calibration is Performed According to the Following Standards:

- IEEE Std 1528-2013, "IEEE Recommended Practice for Determining the Peak Spatial-Averaged Specific Absorption Rate (SAR) in the Human Head from Wireless Communications Devices: Measurement Techniques", June 2013
- IEC 62209-1, "Measurement procedure for the assessment of Specific Absorption Rate (SAR) from hand-held and body-mounted devices used next to the ear (frequency range of 300 MHz to 6 GHz)", July 2016
- IEC 62209-2, "Procedure to determine the Specific Absorption Rate (SAR) for wireless communication devices used in close proximity to the human body (frequency range of 30 MHz to 6 GHz)", March 2010
- KDB 865664, "SAR Measurement Requirements for 100 MHz to 6 GHz"

### Additional Documentation:

- DASY4/5 System Handbook

### Methods Applied and Interpretation of Parameters:

- Measurement Conditions:** Further details are available from the Validation Report at the end of the certificate. All figures stated in the certificate are valid at the frequency indicated.
- Antenna Parameters with TSL:** The dipole is mounted with the spacer to position its feed point exactly below the center marking of the flat phantom section, with the arms oriented parallel to the body axis.
- Feed Point Impedance and Return Loss:** These parameters are measured with the dipole positioned under the liquid filled phantom. The impedance stated is transformed from the measurement at the SMA connector to the feed point. The Return Loss ensures low reflected power. No uncertainty required.
- Electrical Delay:** One-way delay between the SMA connector and the antenna feed point. No uncertainty required.
- SAR measured:** SAR measured at the stated antenna input power.
- SAR normalized:** SAR as measured, normalized to an input power of 1 W at the antenna connector.
- SAR for nominal TSL parameters:** The measured TSL parameters are used to calculate the nominal SAR result.

The reported uncertainty of measurement is stated as the standard uncertainty of measurement multiplied by the coverage factor  $k=2$ , which for a normal distribution corresponds to a coverage probability of approximately 95%.

## Measurement Conditions

DASY system configuration, as far as not given on page 1.

<b>DASY Version</b>	DASY5	V52.10.0
<b>Extrapolation</b>	Advanced Extrapolation	
<b>Phantom</b>	Modular Flat Phantom	
<b>Distance Dipole Center - TSL</b>	10 mm	with Spacer
<b>Zoom Scan Resolution</b>	dx, dy, dz = 5 mm	
<b>Frequency</b>	1750 MHz ± 1 MHz	

## Head TSL parameters

The following parameters and calculations were applied.

	Temperature	Permittivity	Conductivity
<b>Nominal Head TSL parameters</b>	22.0 °C	40.1	1.37 mho/m
<b>Measured Head TSL parameters</b>	(22.0 ± 0.2) °C	39.1 ± 6 %	1.36 mho/m ± 6 %
<b>Head TSL temperature change during test</b>	< 0.5 °C	----	----

## SAR result with Head TSL

<b>SAR averaged over 1 cm<sup>3</sup> (1 g) of Head TSL</b>	Condition	
SAR measured	250 mW input power	9.11 W/kg
SAR for nominal Head TSL parameters	normalized to 1W	<b>36.4 W/kg ± 17.0 % (k=2)</b>

<b>SAR averaged over 10 cm<sup>3</sup> (10 g) of Head TSL</b>	condition	
SAR measured	250 mW input power	4.79 W/kg
SAR for nominal Head TSL parameters	normalized to 1W	<b>19.1 W/kg ± 16.5 % (k=2)</b>

## Body TSL parameters

The following parameters and calculations were applied.

	Temperature	Permittivity	Conductivity
<b>Nominal Body TSL parameters</b>	22.0 °C	53.4	1.49 mho/m
<b>Measured Body TSL parameters</b>	(22.0 ± 0.2) °C	53.8 ± 6 %	1.46 mho/m ± 6 %
<b>Body TSL temperature change during test</b>	< 0.5 °C	----	----

## SAR result with Body TSL

<b>SAR averaged over 1 cm<sup>3</sup> (1 g) of Body TSL</b>	Condition	
SAR measured	250 mW input power	9.02 W/kg
SAR for nominal Body TSL parameters	normalized to 1W	<b>36.6 W/kg ± 17.0 % (k=2)</b>

<b>SAR averaged over 10 cm<sup>3</sup> (10 g) of Body TSL</b>	condition	
SAR measured	250 mW input power	4.81 W/kg
SAR for nominal Body TSL parameters	normalized to 1W	<b>19.4 W/kg ± 16.5 % (k=2)</b>

## Appendix (Additional assessments outside the scope of SCS 0108)

### Antenna Parameters with Head TSL

Impedance, transformed to feed point	51.6 $\Omega$ - 0.1 j $\Omega$
Return Loss	- 35.9 dB

### Antenna Parameters with Body TSL

Impedance, transformed to feed point	47.5 $\Omega$ - 0.4 j $\Omega$
Return Loss	- 31.7 dB

### General Antenna Parameters and Design

Electrical Delay (one direction)	1.221 ns
----------------------------------	----------

After long term use with 100W radiated power, only a slight warming of the dipole near the feedpoint can be measured.

The dipole is made of standard semirigid coaxial cable. The center conductor of the feeding line is directly connected to the second arm of the dipole. The antenna is therefore short-circuited for DC-signals. On some of the dipoles, small end caps are added to the dipole arms in order to improve matching when loaded according to the position as explained in the "Measurement Conditions" paragraph. The SAR data are not affected by this change. The overall dipole length is still according to the Standard.

No excessive force must be applied to the dipole arms, because they might bend or the soldered connections near the feedpoint may be damaged.

### Additional EUT Data

Manufactured by	SPEAG
Manufactured on	June 03, 2014



# DASY5 Validation Report for Head TSL

Date: 20.09.2017

Test Laboratory: SPEAG, Zurich, Switzerland

**DUT: Dipole 1750 MHz; Type: D1750V2; Serial: D1750V2 - SN:1126**

Communication System: UID 0 - CW; Frequency: 1750 MHz

Medium parameters used:  $f = 1750$  MHz;  $\sigma = 1.36$  S/m;  $\epsilon_r = 39.1$ ;  $\rho = 1000$  kg/m<sup>3</sup>

Phantom section: Flat Section

Measurement Standard: DASY5 (IEEE/IEC/ANSI C63.19-2011)

DASY52 Configuration:

- Probe: EX3DV4 - SN7349; ConvF(8.73, 8.73, 8.73); Calibrated: 31.05.2017;
- Sensor-Surface: 1.4mm (Mechanical Surface Detection)
- Electronics: DAE4 Sn601; Calibrated: 28.03.2017
- Phantom: Flat Phantom 5.0 (front); Type: QD 000 P50 AA; Serial: 1001
- DASY52 52.10.0(1446); SEMCAD X 14.6.10(7417)

## Dipole Calibration for Head Tissue/Pin=250 mW, d=10mm/Zoom Scan (7x7x7)/Cube 0:

Measurement grid: dx=5mm, dy=5mm, dz=5mm

Reference Value = 103.1 V/m; Power Drift = -0.05 dB

Peak SAR (extrapolated) = 17.2 W/kg

**SAR(1 g) = 9.11 W/kg; SAR(10 g) = 4.79 W/kg**

Maximum value of SAR (measured) = 13.6 W/kg

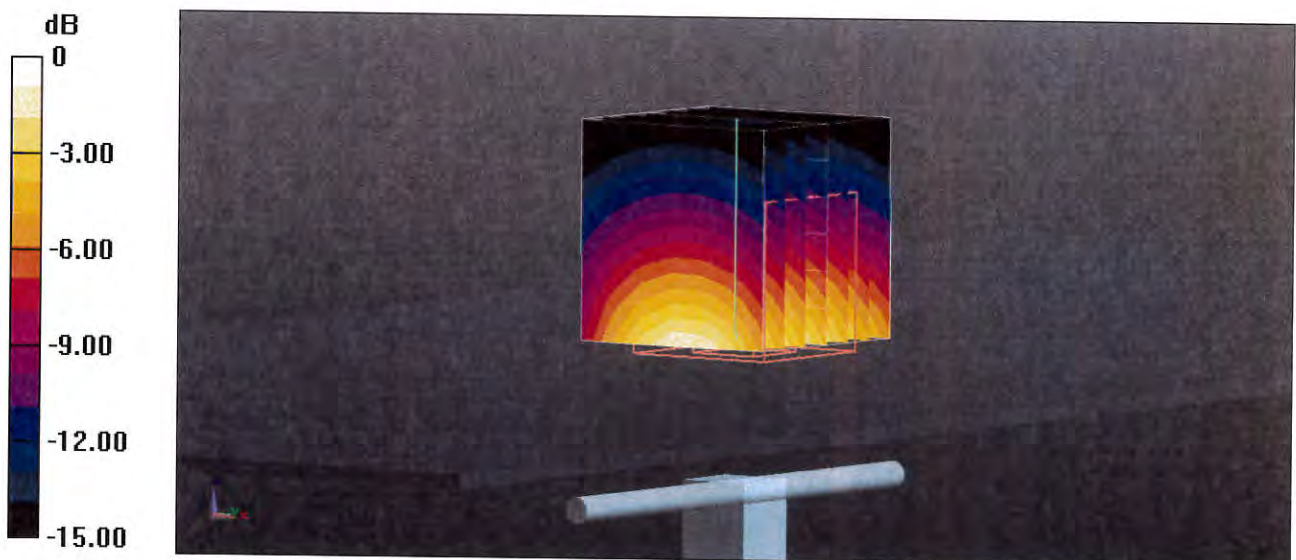

0 dB = 13.6 W/kg = 11.34 dBW/kg

# Impedance Measurement Plot for Head TSL

20 Sep 2017 10:02:31  
[CH1] S11 1 U FS 1: 51.627  $\Omega$  -76.172 m $\Omega$  1.1940 nF 1 750.000 000 MHz

\*  
De1  
CA  
Avg  
16  
H1d

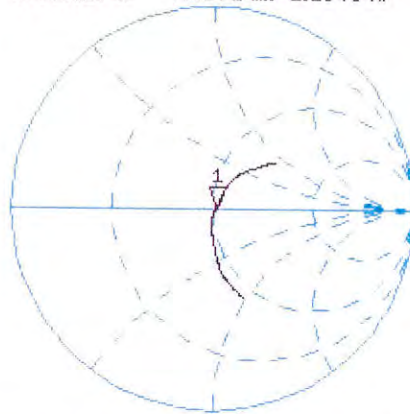

CH2 S11 LOG 5 dB/REF -20 dB 1:-35.916 dB 1 750.000 000 MHz

CA  
Avg  
16  
H1d

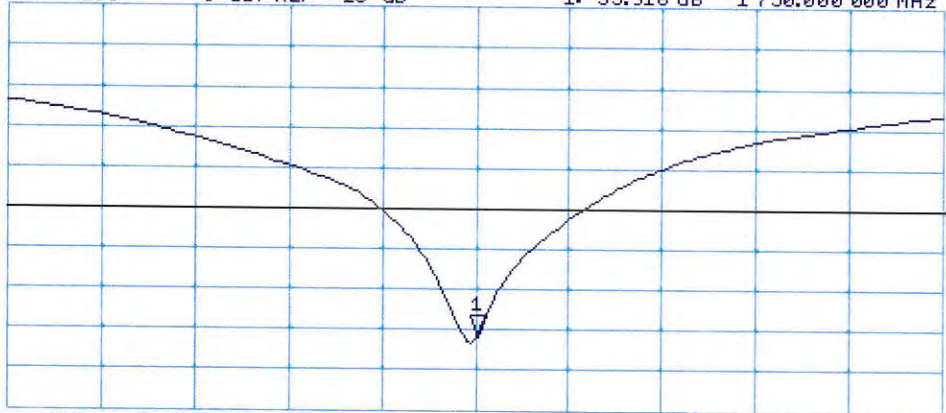

START 1 550.000 000 MHz

STOP 1 950.000 000 MHz

## DASY5 Validation Report for Body TSL

Date: 20.09.2017

Test Laboratory: SPEAG, Zurich, Switzerland

**DUT: Dipole 1750 MHz; Type: D1750V2; Serial: D1750V2 - SN:1126**

Communication System: UID 0 - CW; Frequency: 1750 MHz

Medium parameters used:  $f = 1750$  MHz;  $\sigma = 1.46$  S/m;  $\epsilon_r = 53.8$ ;  $\rho = 1000$  kg/m<sup>3</sup>

Phantom section: Flat Section

Measurement Standard: DASY5 (IEEE/IEC/ANSI C63.19-2011)

DASY52 Configuration:

- Probe: EX3DV4 - SN7349; ConvF(8.46, 8.46, 8.46); Calibrated: 31.05.2017;
- Sensor-Surface: 1.4mm (Mechanical Surface Detection)
- Electronics: DAE4 Sn601; Calibrated: 28.03.2017
- Phantom: Flat Phantom 5.0 (back); Type: QD 000 P50 AA; Serial: 1002
- DASY52 52.10.0(1446); SEMCAD X 14.6.10(7417)

### Dipole Calibration for Body Tissue/Pin=250 mW, d=10mm/Zoom Scan (7x7x7)/Cube 0:

Measurement grid: dx=5mm, dy=5mm, dz=5mm

Reference Value = 98.75 V/m; Power Drift = -0.07 dB

Peak SAR (extrapolated) = 15.8 W/kg

**SAR(1 g) = 9.02 W/kg; SAR(10 g) = 4.81 W/kg**

Maximum value of SAR (measured) = 12.9 W/kg

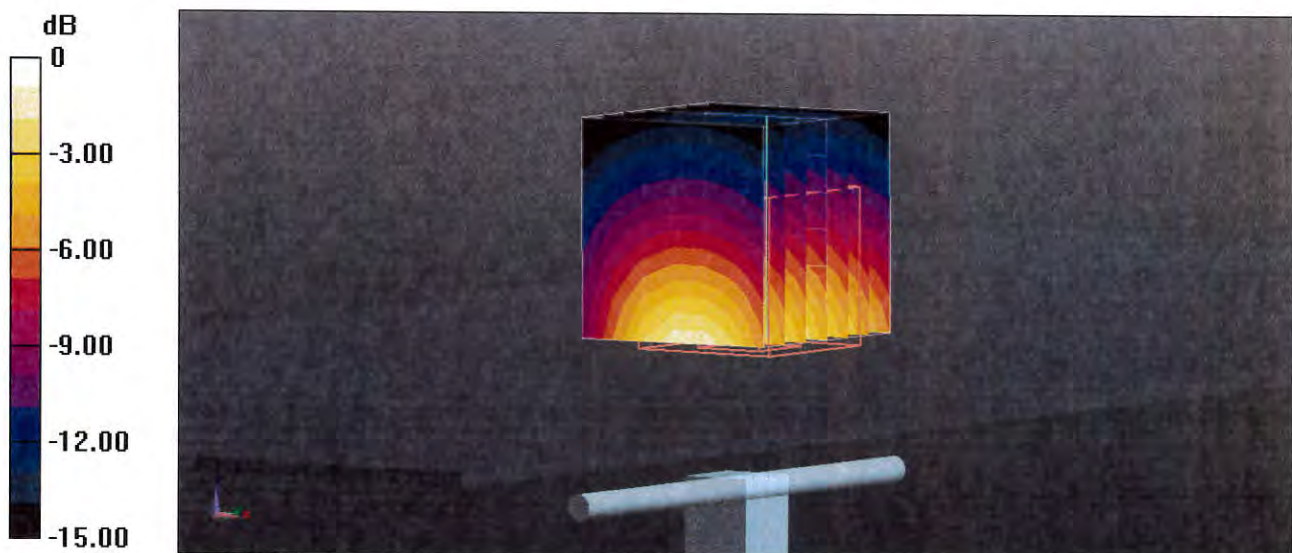



# Impedance Measurement Plot for Body TSL

20 Sep 2017 10:01:54  
[CH1] S11 1 U FS 1: 47.500  $\Omega$  -431.64 m $\Omega$  210.70 pF 1 750.000 000 MHz

\*  
Del  
CA  
Avg  
16  
H1d

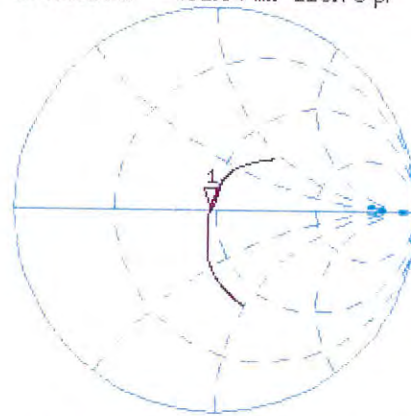

CH2 S11 LOG 5 dB/REF -20 dB 1:-31.704 dB 1 750.000 000 MHz

CA  
Avg  
16  
H1d



# Validation Report

## No. VAL\_0947\_EF 2019-03

Kind of doc.:  
QM Template

**EUROFINS PRODUCT SERVICE GmbH**  
Storkower Str. 38c, 15526 Reichenwalde, Germany

### 1 Customer

Eurofins Product Service GmbH

### 2 Object

Equipment Number: EF00947  
 Equipment Name: System validation dipole  
 Equipment Type: D1750V2  
 Serial Number: 1126  
 Manufacturer: Schmid & Partner Engineering AG

### 3 State of Measurement

Validation:   
 Performance Control:   
 Other:

### 4 Performance of Measurement

#### 4.1 Generals

(e.g. object of validation such as specific setup, non-standard method or SW, specification of the requirements, test set-up configuration, risk analysis etc.)

Dipol verification

#### 4.2 Validation procedure / measurement

(e.g. comparison of results achieved with other methods, interlaboratory comparison, systematic assessment of factors influencing the result, assessment of the uncertainty of the results based on scientific understanding of the theoretical principles of the method and practical experience; criteria/requirements for approval/rejection etc.)

According KDB 865664 D01 SAR Measurement 100 MHz to 6 GHz v01r04 3.2.2 Dipole calibration

Limits for the verification: return loss <20% to the original measurement or >20 dB minimum return-loss  
 Impedance <5 Ω to the original measurement.

#### 4.3 Used reference equipment

Equipment name	Equipment type	Manufacturer	Equipment number	Cal. Date	Cal. Due Date
RF Network analyzer	8752 C	Hewlett-Packard Company Santa Clara	EF00140	2018-07-25	2019-07-25

- new acquired (incl. calibration)
- new calibrated
- check reference standard

#### 4.4 Environmental conditions

Temperature: \_23\_ °C ± 2°C  
 Relative Air Humidity: \_50\_ rH ± 5%  
 Air Pressure: \_1020\_ hPa ± 5%

# Validation Report

## No. VAL\_0947\_EF 2019-03

 Kind of doc.:  
 QM Template

 EUROFINS PRODUCT SERVICE GmbH  
 Storkower Str. 38c, 15526 Reichenwalde, Germany

**5 Results**
**5.1 General:**

(e.g. measurement results, user instructions such as handling, transport, storage, preparation; checks to be made before the work started; information about how to install (operations)-, to maintain-, to train and to use; safety measures etc.)

	Original measurement	Verification measurement	Margin
Impedance, transformend to feed point	47.5 $\Omega$ + 0.4 j $\Omega$	47.94 $\Omega$ + 1.32 j $\Omega$	0.44 $\Omega$ + 0.38j $\Omega$
Return Loss	-31.7 dB	-32.06 dB	0.36 dB
Tissue Validation $\epsilon_r$	53.8	53.881	0.15 %
Tissue Validation $\sigma$ [S/m]	1.46	1.51	3.42 %
System validation	36.08 W/kg (1g)	36.6W/kg (1g)	1.50 %
Date:	20.09.2017	13.03.2019	

**5.2 Measurement uncertainty**

 The reported expanded uncertainty of measurement is stated as the standard uncertainty multiplied by the coverage factor k=2, which for a normal distribution corresponds to a coverage probability of approximately 95%.  
 +/- 2.5 %

**5.3 Results of Validation**

 Validated 
  
 Not validated 
**6 Operator**

 Pudell   
 Name Signature

Place and Date of Verification: Reichenwalde, 13.03.2019

Attachment:

Impedance, Return Loss, System validierung



# Validation Report

## No. VAL\_0947\_EF 2019-03

Kind of doc.:  
QM Template

**EUROFINS PRODUCT SERVICE GmbH**  
Storkower Str. 38c, 15526 Reichenwalde, Germany

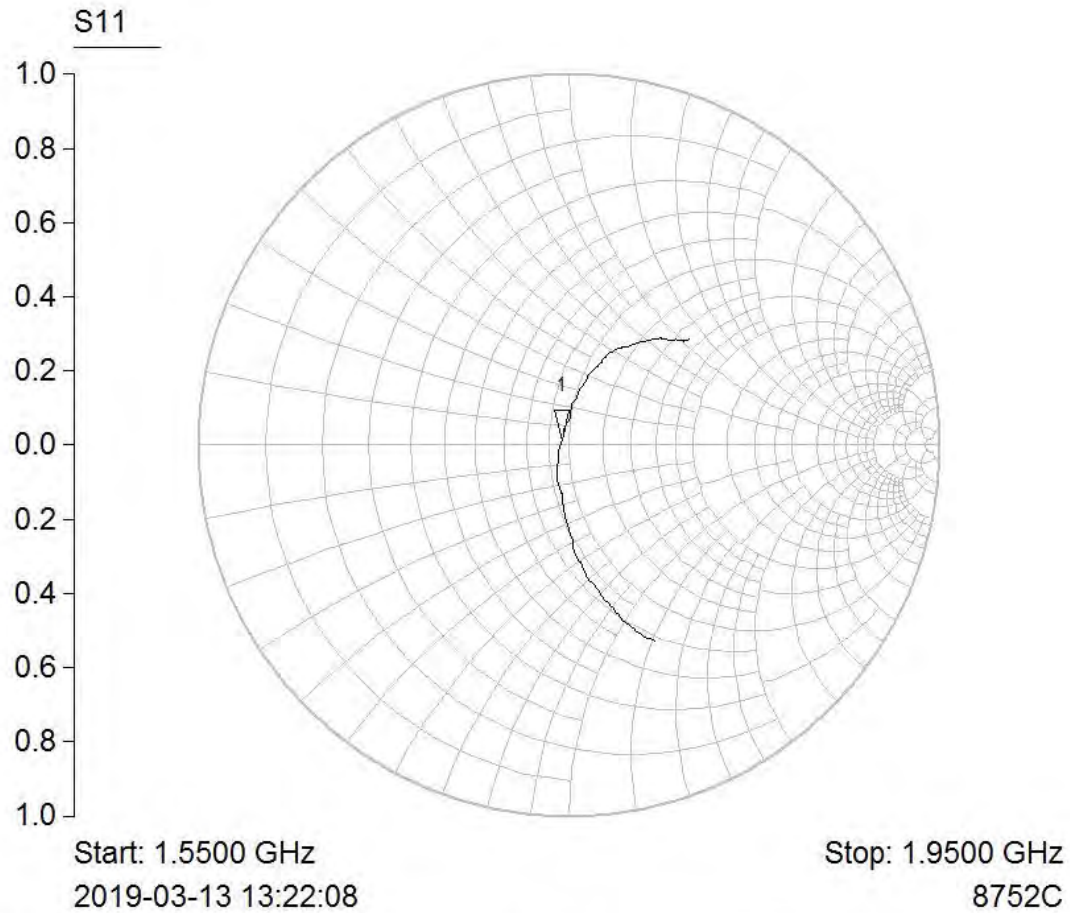

Mkr	Trace	X-Axis	Value	Notes
1 ▽	S11	1.7500 GHz	47.94 + j1.32 ohms	

# Validation Report

## No. VAL\_0947\_EF 2019-03

 Kind of doc.:  
 QM Template

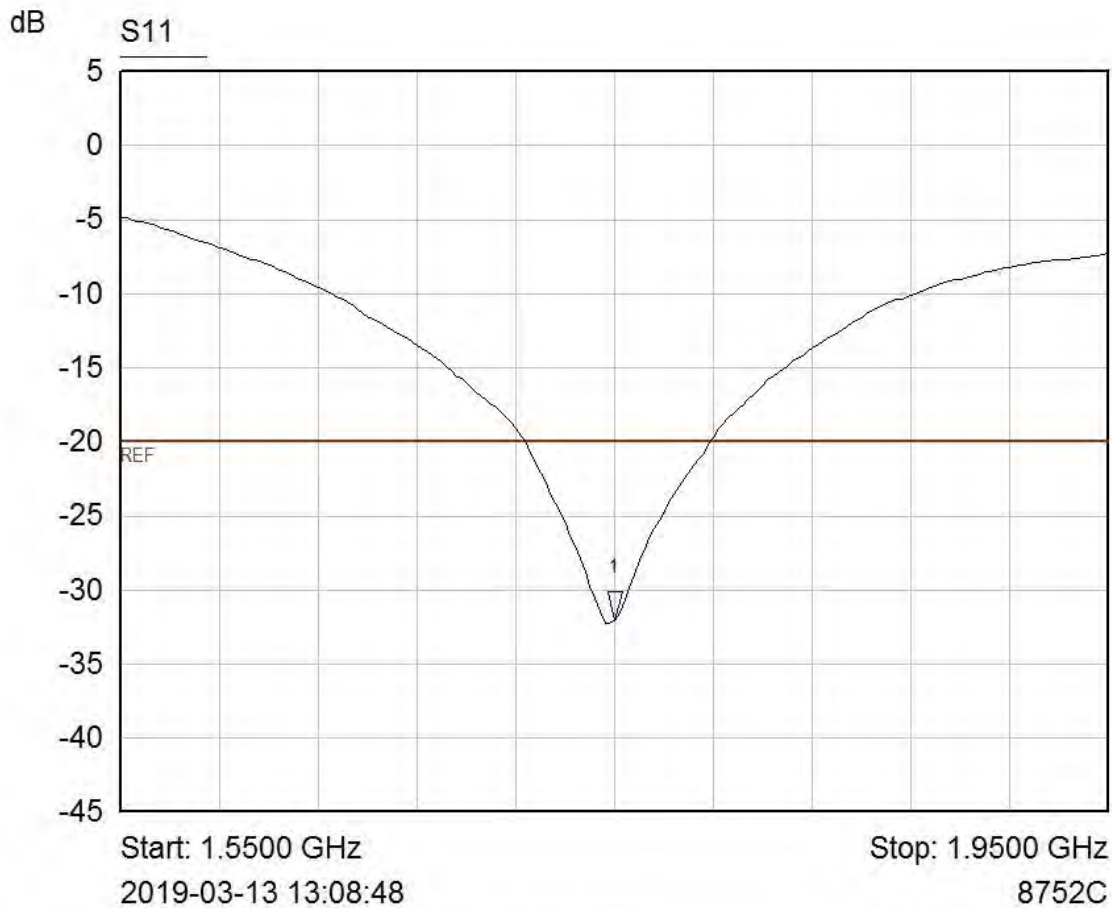
**EUROFINS PRODUCT SERVICE GmbH**  
 Storkower Str. 38c, 15526 Reichenwalde, Germany

Mkr	Trace	X-Axis	Value	Notes
1 ▽	S11	1.7500 GHz	-32.06 dB	

# Validation Report

## No. VAL\_0947\_EF 2019-03

Kind of doc.:  
QM Template

EUROFINS PRODUCT SERVICE GmbH  
Storkower Str. 38c, 15526 Reichenwalde, Germany

Date Time: 2019-03-13 07:33:12

**Test Laboratory: Eurofins Product Service GmbH**

**Dipol Valid.1750 (m)\_250mW ELI4\_13.03.2019**

**DUT: Dipole 1750 MHz (D1750V2); Type: SA AAD 175 AA; Serial: 1126**

Communication System: UID 0 - n/a. CW; Frequency: 1750 MHz; Duty Cycle: 1:1  
 Medium: Muscle 1800 MHz Medium parameters used:  $f = 1750 \text{ MHz}$ ;  $\sigma = 1.51 \text{ S/m}$ ;  $\epsilon_r = 53.881$ ;  $\rho = 1000 \text{ kg/m}^3$   
 Phantom section: Flat Section

Measurement Standard: DASYS (IEEE/IEC/ANSI C63.19-2007)

**DASY5.2 Configuration:**

- Probe: EX3DV4 - SN3893; Com:F(8.66, 8.66, 8.66); Calibrated: 2018-09-20;
- Sensor-Surface: 4mm (Mechanical Surface Detection)
- Electronics: DAE3 Sn522; Calibrated: 2018-09-17
- Phantom: Flat Phantom ELI4.0; Type: QDOVA001BB; Serial: SN:1013
- Measurement SW: DASYS2, Version 52.8 (6); SEMCAD X Version 14.6.9 (7117)

**System Performance Check at Frequencies above 1 GHz/d=10mm, Pin=250 mW, dist=4.0mm (EX-Probe)/Area Scan (7x9x1):** Measurement grid: dx=15mm, dy=15mm  
 Maximum value of SAR (measured) = 8.20 W/kg

**System Performance Check at Frequencies above 1 GHz/d=10mm, Pin=250 mW, dist=4.0mm (EX-Probe)/Zoom Scan (7x7x7) (7x7x7)/Cube 0:** Measurement grid: dx=5mm, dy=5mm, dz=5mm  
 Reference Value = 82.432 V/m; Power Drift = 0.01 dB  
 Peak SAR (extrapolated) = 16.4 W/kg  
 SAR(1 g) = 9.15 W/kg; SAR(10 g) = 4.9 W/kg  
 Maximum value of SAR (measured) = 10.3 W/kg

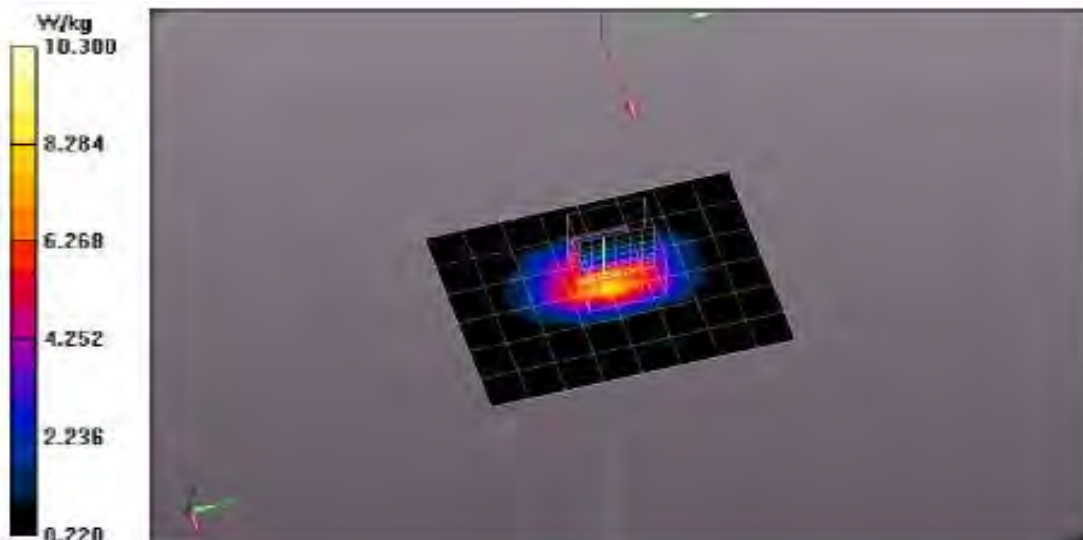





Accredited by the Swiss Accreditation Service (SAS)  
The Swiss Accreditation Service is one of the signatories to the EA  
Multilateral Agreement for the recognition of calibration certificates

Accreditation No.: **SCS 0108**

Client **Eurofins**

Certificate No: **D1900V2-5d025\_Sep18**

## CALIBRATION CERTIFICATE

Object **D1900V2 - SN:5d025**

Calibration procedure(s) **QA CAL-05.v10  
Calibration procedure for dipole validation kits above 700 MHz**

Calibration date: **September 14, 2018**

This calibration certificate documents the traceability to national standards, which realize the physical units of measurements (SI).  
The measurements and the uncertainties with confidence probability are given on the following pages and are part of the certificate.

All calibrations have been conducted in the closed laboratory facility: environment temperature ( $22 \pm 3$ )°C and humidity < 70%.

Calibration Equipment used (M&TE critical for calibration)

Primary Standards	ID #	Cal Date (Certificate No.)	Scheduled Calibration
Power meter NRP	SN: 104778	04-Apr-18 (No. 217-02672/02673)	Apr-19
Power sensor NRP-Z91	SN: 103244	04-Apr-18 (No. 217-02672)	Apr-19
Power sensor NRP-Z91	SN: 103245	04-Apr-18 (No. 217-02673)	Apr-19
Reference 20 dB Attenuator	SN: 5058 (20k)	04-Apr-18 (No. 217-02682)	Apr-19
Type-N mismatch combination	SN: 5047.2 / 06327	04-Apr-18 (No. 217-02683)	Apr-19
Reference Probe EX3DV4	SN: 7349	30-Dec-17 (No. EX3-7349_Dec17)	Dec-18
DAE4	SN: 601	26-Oct-17 (No. DAE4-601_Oct17)	Oct-18

Secondary Standards	ID #	Check Date (in house)	Scheduled Check
Power meter EPM-442A	SN: GB37480704	07-Oct-15 (in house check Oct-16)	In house check: Oct-18
Power sensor HP 8481A	SN: US37292783	07-Oct-15 (in house check Oct-16)	In house check: Oct-18
Power sensor HP 8481A	SN: MY41092317	07-Oct-15 (in house check Oct-16)	In house check: Oct-18
RF generator R&S SMT-06	SN: 100972	15-Jun-15 (in house check Oct-16)	In house check: Oct-18
Network Analyzer Agilent E8358A	SN: US41080477	31-Mar-14 (in house check Oct-17)	In house check: Oct-18

Calibrated by: **Manu Seitz**      Name: **Manu Seitz**      Function: **Laboratory Technician**

Approved by: **Katja Pokovic**      Name: **Katja Pokovic**      Function: **Technical Manager**

Signature

Issued: September 14, 2018

This calibration certificate shall not be reproduced except in full without written approval of the laboratory.





Accredited by the Swiss Accreditation Service (SAS)

The Swiss Accreditation Service is one of the signatories to the EA  
Multilateral Agreement for the recognition of calibration certificates

Accreditation No.: **SCS 0108**

### Glossary:

TSL	tissue simulating liquid
ConvF	sensitivity in TSL / NORM x,y,z
N/A	not applicable or not measured

### Calibration is Performed According to the Following Standards:

- IEEE Std 1528-2013, "IEEE Recommended Practice for Determining the Peak Spatial-Averaged Specific Absorption Rate (SAR) in the Human Head from Wireless Communications Devices: Measurement Techniques", June 2013
- IEC 62209-1, "Measurement procedure for the assessment of Specific Absorption Rate (SAR) from hand-held and body-mounted devices used next to the ear (frequency range of 300 MHz to 6 GHz)", July 2016
- IEC 62209-2, "Procedure to determine the Specific Absorption Rate (SAR) for wireless communication devices used in close proximity to the human body (frequency range of 30 MHz to 6 GHz)", March 2010
- KDB 865664, "SAR Measurement Requirements for 100 MHz to 6 GHz"

### Additional Documentation:

- DASY4/5 System Handbook

### Methods Applied and Interpretation of Parameters:

- Measurement Conditions:** Further details are available from the Validation Report at the end of the certificate. All figures stated in the certificate are valid at the frequency indicated.
- Antenna Parameters with TSL:** The dipole is mounted with the spacer to position its feed point exactly below the center marking of the flat phantom section, with the arms oriented parallel to the body axis.
- Feed Point Impedance and Return Loss:** These parameters are measured with the dipole positioned under the liquid filled phantom. The impedance stated is transformed from the measurement at the SMA connector to the feed point. The Return Loss ensures low reflected power. No uncertainty required.
- Electrical Delay:** One-way delay between the SMA connector and the antenna feed point. No uncertainty required.
- SAR measured:** SAR measured at the stated antenna input power.
- SAR normalized:** SAR as measured, normalized to an input power of 1 W at the antenna connector.
- SAR for nominal TSL parameters:** The measured TSL parameters are used to calculate the nominal SAR result.

The reported uncertainty of measurement is stated as the standard uncertainty of measurement multiplied by the coverage factor  $k=2$ , which for a normal distribution corresponds to a coverage probability of approximately 95%.

## Measurement Conditions

DASY system configuration, as far as not given on page 1.

<b>DASY Version</b>	DASY5	V52.10.1
<b>Extrapolation</b>	Advanced Extrapolation	
<b>Phantom</b>	Modular Flat Phantom	
<b>Distance Dipole Center - TSL</b>	10 mm	with Spacer
<b>Zoom Scan Resolution</b>	dx, dy, dz = 5 mm	
<b>Frequency</b>	1900 MHz ± 1 MHz	

## Head TSL parameters

The following parameters and calculations were applied.

	Temperature	Permittivity	Conductivity
<b>Nominal Head TSL parameters</b>	22.0 °C	40.0	1.40 mho/m
<b>Measured Head TSL parameters</b>	(22.0 ± 0.2) °C	40.2 ± 6 %	1.40 mho/m ± 6 %
<b>Head TSL temperature change during test</b>	< 0.5 °C	----	----

## SAR result with Head TSL

<b>SAR averaged over 1 cm<sup>3</sup> (1 g) of Head TSL</b>	Condition	
SAR measured	250 mW input power	9.98 W/kg
SAR for nominal Head TSL parameters	normalized to 1W	<b>40.0 W/kg ± 17.0 % (k=2)</b>

<b>SAR averaged over 10 cm<sup>3</sup> (10 g) of Head TSL</b>	condition	
SAR measured	250 mW input power	5.23 W/kg
SAR for nominal Head TSL parameters	normalized to 1W	<b>20.9 W/kg ± 16.5 % (k=2)</b>

## Body TSL parameters

The following parameters and calculations were applied.

	Temperature	Permittivity	Conductivity
<b>Nominal Body TSL parameters</b>	22.0 °C	53.3	1.52 mho/m
<b>Measured Body TSL parameters</b>	(22.0 ± 0.2) °C	53.3 ± 6 %	1.47 mho/m ± 6 %
<b>Body TSL temperature change during test</b>	< 0.5 °C	----	----

## SAR result with Body TSL

<b>SAR averaged over 1 cm<sup>3</sup> (1 g) of Body TSL</b>	Condition	
SAR measured	250 mW input power	9.81 W/kg
SAR for nominal Body TSL parameters	normalized to 1W	<b>40.0 W/kg ± 17.0 % (k=2)</b>

<b>SAR averaged over 10 cm<sup>3</sup> (10 g) of Body TSL</b>	condition	
SAR measured	250 mW input power	5.18 W/kg
SAR for nominal Body TSL parameters	normalized to 1W	<b>21.0 W/kg ± 16.5 % (k=2)</b>



## Appendix (Additional assessments outside the scope of SCS 0108)

### Antenna Parameters with Head TSL

Impedance, transformed to feed point	$51.4 \Omega + 5.9 j\Omega$
Return Loss	- 24.4 dB

### Antenna Parameters with Body TSL

Impedance, transformed to feed point	$47.3 \Omega + 7.4 j\Omega$
Return Loss	- 21.9 dB

### General Antenna Parameters and Design

Electrical Delay (one direction)	1.198 ns
----------------------------------	----------

After long term use with 100W radiated power, only a slight warming of the dipole near the feedpoint can be measured.

The dipole is made of standard semirigid coaxial cable. The center conductor of the feeding line is directly connected to the second arm of the dipole. The antenna is therefore short-circuited for DC-signals. On some of the dipoles, small end caps are added to the dipole arms in order to improve matching when loaded according to the position as explained in the "Measurement Conditions" paragraph. The SAR data are not affected by this change. The overall dipole length is still according to the Standard.

No excessive force must be applied to the dipole arms, because they might bend or the soldered connections near the feedpoint may be damaged.

### Additional EUT Data

Manufactured by	SPEAG
Manufactured on	July 29, 2002

## DASY5 Validation Report for Head TSL

Date: 14.09.2018

Test Laboratory: SPEAG, Zurich, Switzerland

**DUT: Dipole 1900 MHz; Type: D1900V2; Serial: D1900V2 - SN:5d025**

Communication System: UID 0 - CW; Frequency: 1900 MHz

Medium parameters used:  $f = 1900$  MHz;  $\sigma = 1.4$  S/m;  $\epsilon_r = 40.2$ ;  $\rho = 1000$  kg/m<sup>3</sup>

Phantom section: Flat Section

Measurement Standard: DASY5 (IEEE/IEC/ANSI C63.19-2011)

DASY52 Configuration:

- Probe: EX3DV4 - SN7349; ConvF(8.18, 8.18, 8.18) @ 1900 MHz; Calibrated: 30.12.2017
- Sensor-Surface: 1.4mm (Mechanical Surface Detection)
- Electronics: DAE4 Sn601; Calibrated: 26.10.2017
- Phantom: Flat Phantom 5.0 (front); Type: QD 000 P50 AA; Serial: 1001
- DASY52 52.10.1(1476); SEMCAD X 14.6.11(7439)

### Dipole Calibration for Head Tissue/Pin=250 mW, d=10mm/Zoom Scan (7x7x7)/Cube 0:

Measurement grid: dx=5mm, dy=5mm, dz=5mm

Reference Value = 110.0 V/m; Power Drift = -0.08 dB

Peak SAR (extrapolated) = 18.5 W/kg

**SAR(1 g) = 9.98 W/kg; SAR(10 g) = 5.23 W/kg**

Maximum value of SAR (measured) = 15.4 W/kg

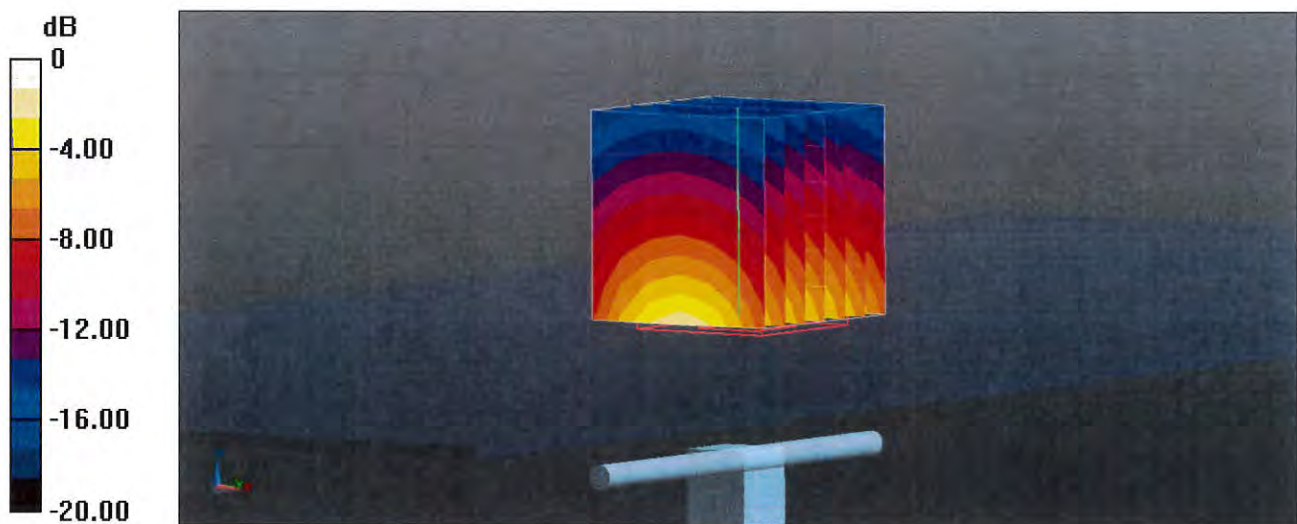

# Impedance Measurement Plot for Head TSL

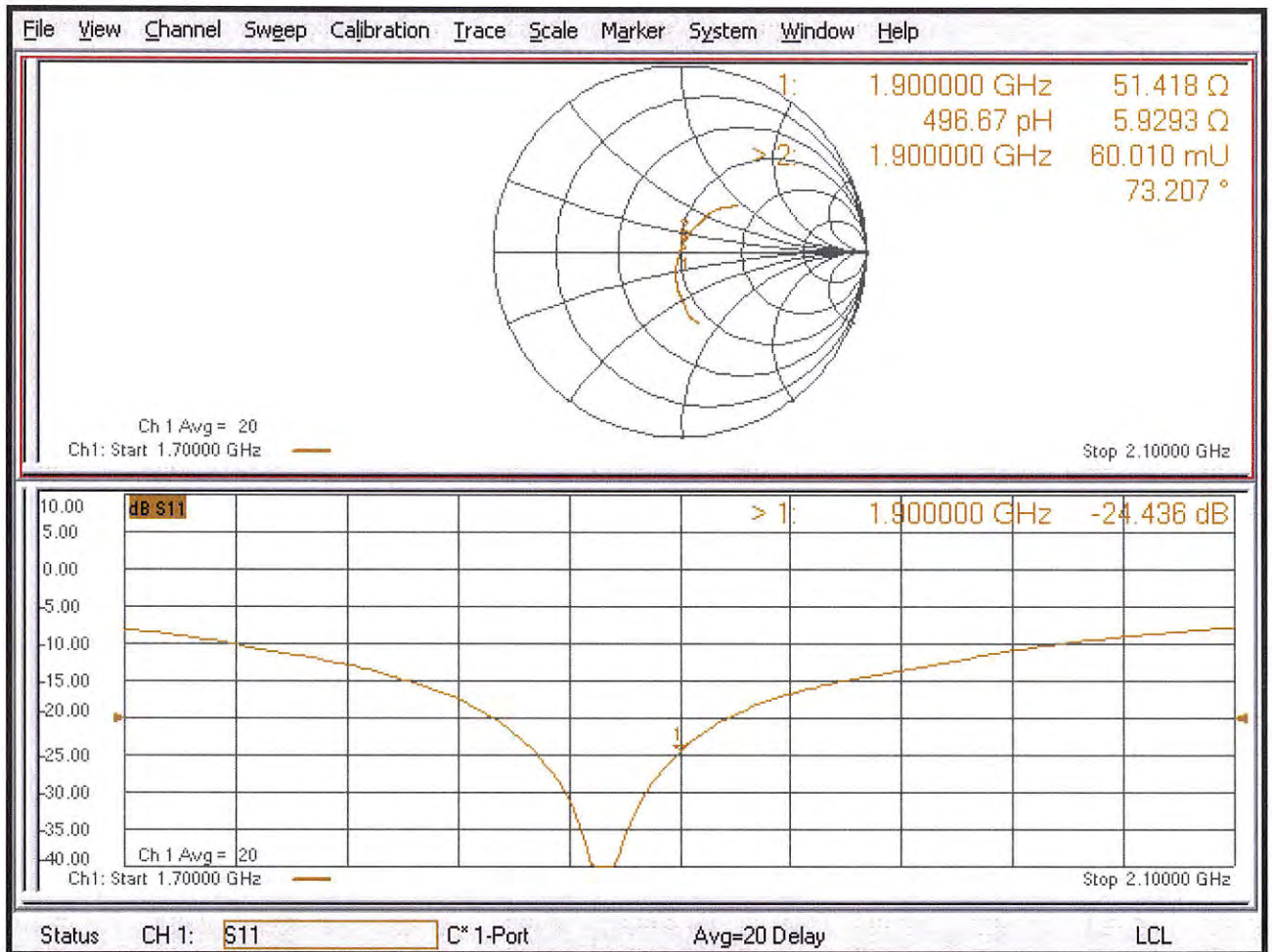



## DASY5 Validation Report for Body TSL

Date: 14.09.2018

Test Laboratory: SPEAG, Zurich, Switzerland

**DUT: Dipole 1900 MHz; Type: D1900V2; Serial: D1900V2 - SN:5d025**

Communication System: UID 0 - CW; Frequency: 1900 MHz

Medium parameters used:  $f = 1900$  MHz;  $\sigma = 1.47$  S/m;  $\epsilon_r = 53.3$ ;  $\rho = 1000$  kg/m<sup>3</sup>

Phantom section: Flat Section

Measurement Standard: DASY5 (IEEE/IEC/ANSI C63.19-2011)

DASY52 Configuration:

- Probe: EX3DV4 - SN7349; ConvF(8.15, 8.15, 8.15) @ 1900 MHz; Calibrated: 30.12.2017
- Sensor-Surface: 1.4mm (Mechanical Surface Detection)
- Electronics: DAE4 Sn601; Calibrated: 26.10.2017
- Phantom: Flat Phantom 5.0 (back); Type: QD 000 P50 AA; Serial: 1002
- DASY52 52.10.1(1476); SEMCAD X 14.6.11(7439)

### Dipole Calibration for Body Tissue/Pin=250 mW, d=10mm/Zoom Scan (7x7x7)/Cube 0:

Measurement grid: dx=5mm, dy=5mm, dz=5mm

Reference Value = 105.8 V/m; Power Drift = -0.07 dB

Peak SAR (extrapolated) = 17.7 W/kg

**SAR(1 g) = 9.81 W/kg; SAR(10 g) = 5.18 W/kg**

Maximum value of SAR (measured) = 15.0 W/kg

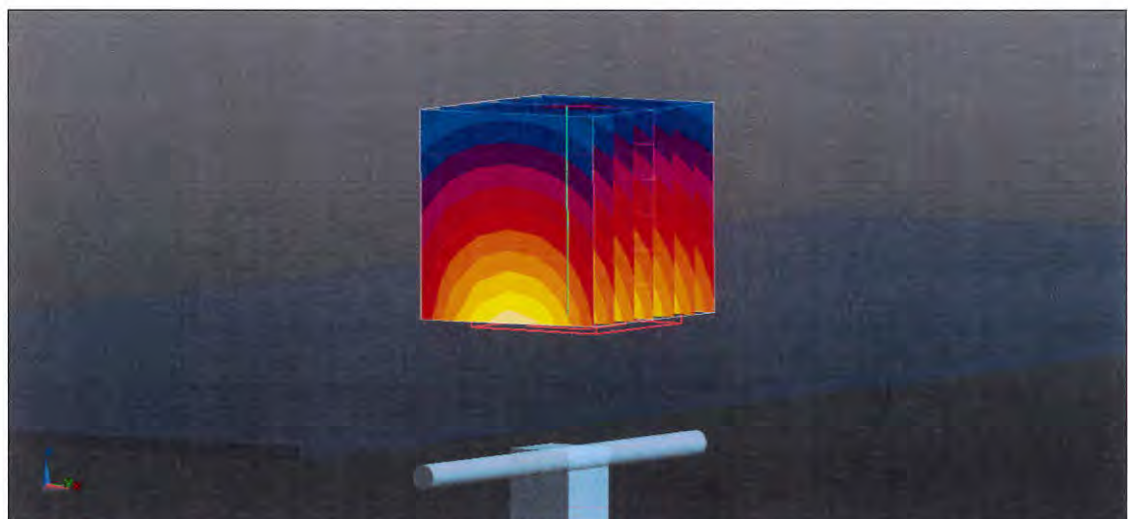
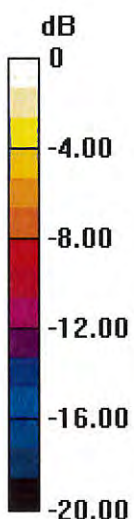

0 dB = 15.0 W/kg = 11.76 dBW/kg

# Impedance Measurement Plot for Body TSL

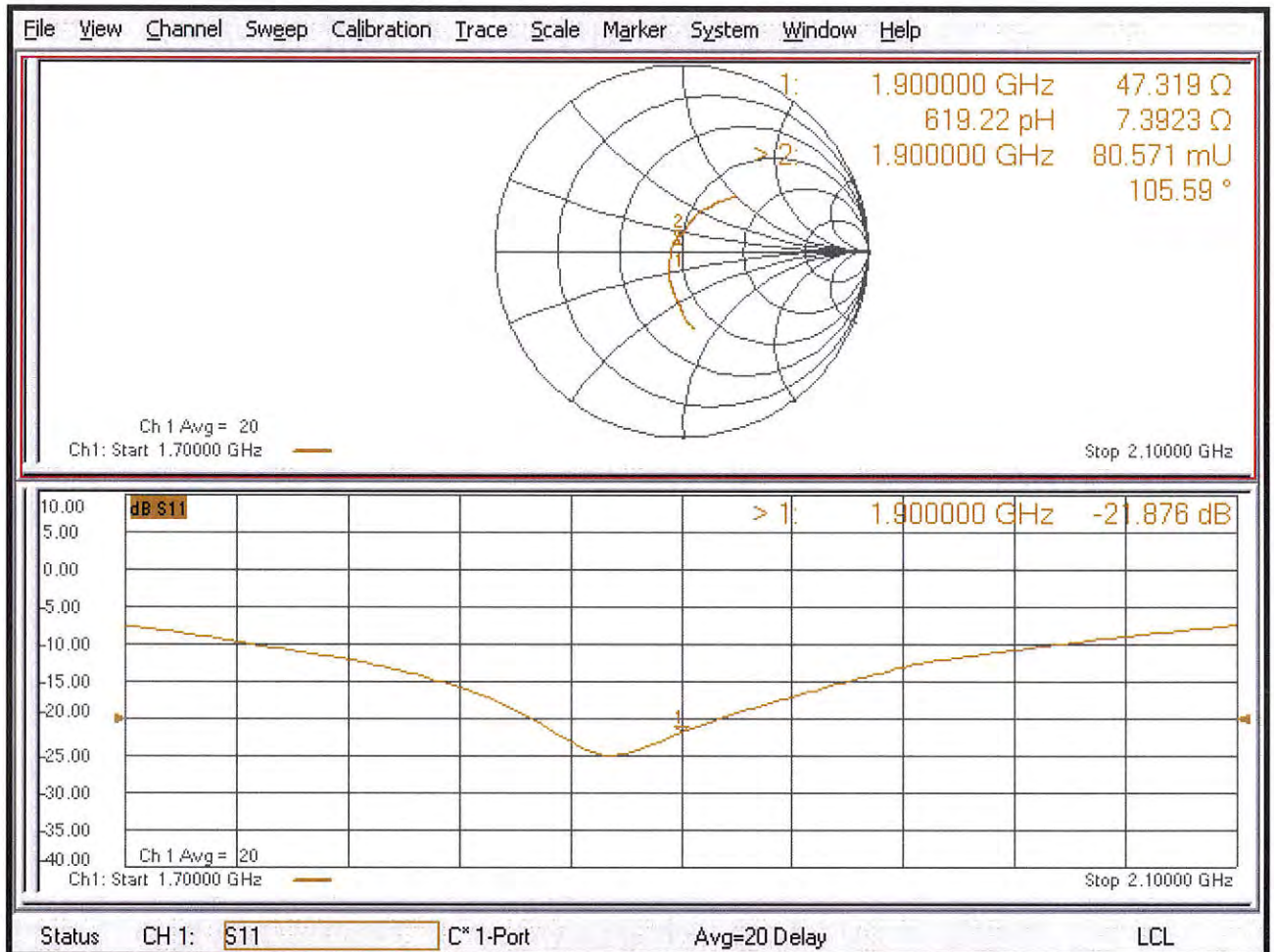

**ANNEX B System Validation Reports**



**Test Laboratory: Eurofins Product Service GmbH**

**Dipol Valid.1750 (m)\_250mW ELI4\_20.05.2019**

**DUT: Dipole 1750 MHz (D1750V2); Type: SA AAD 175 AA; Serial: 1126**

Communication System: UID 0 - n/a, CW; Frequency: 1750 MHz;Duty Cycle: 1:1  
Medium: Muscle 1800 MHz Medium parameters used:  $f = 1750$  MHz;  $\sigma = 1.473$  S/m;  $\epsilon_r = 53.953$ ;  $\rho = 1000$  kg/m<sup>3</sup>  
Phantom section: Flat Section

Measurement Standard: DASYS (IEEE/IEC/ANSI C63.19-2007)

**DASY5.2 Configuration:**

- Probe: EX3DV4 - SN3893; ConvF(8.66, 8.66, 8.66); Calibrated: 2018-09-20;
- Sensor-Surface: 4mm (Mechanical Surface Detection)
- Electronics: DAE3 Sn522; Calibrated: 2018-09-17
- Phantom: Flat Phantom ELI4.0; Type: QDOVA001BB; Serial: SN:1013
- Measurement SW: DASY52, Version 52.8 (6); SEMCAD X Version 14.6.9 (7117)

**System Performance Check at Frequencies above 1 GHz/d=10mm, Pin=250 mW, dist=4.0mm (EX-Probe)/Area Scan (7x9x1):** Measurement grid: dx=15mm, dy=15mm  
Maximum value of SAR (measured) = 8.80 W/kg

**System Performance Check at Frequencies above 1 GHz/d=10mm, Pin=250 mW, dist=4.0mm (EX-Probe)/Zoom Scan (7x7x7) (7x7x7)/Cube 0:** Measurement grid: dx=5mm, dy=5mm, dz=5mm  
Reference Value = 83.929 V/m; Power Drift = 0.02 dB  
Peak SAR (extrapolated) = 17.1 W/kg  
**SAR(1 g) = 9.36 W/kg; SAR(10 g) = 4.94 W/kg**  
Maximum value of SAR (measured) = 10.5 W/kg

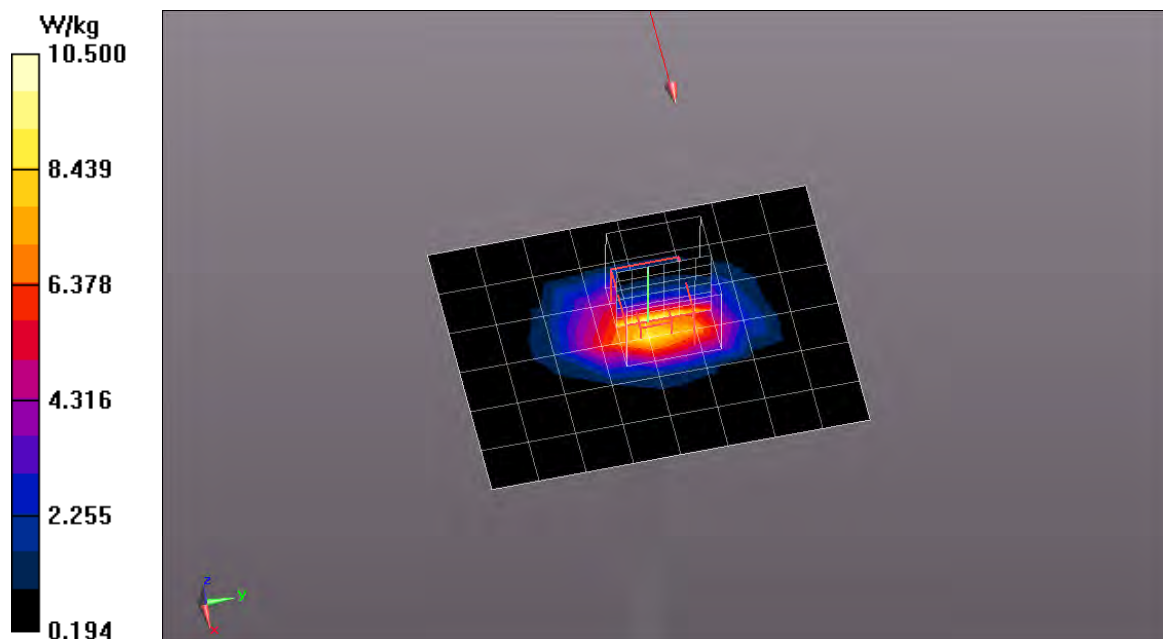

**Test Laboratory: Eurofins Product Service GmbH**

**Dipol Valid.1750 (m)\_250mW ELI4\_21.05.2019**

**DUT: Dipole 1750 MHz (D1750V2); Type: SA AAD 175 AA; Serial: 1126**

Communication System: UID 0 - n/a, CW; Frequency: 1750 MHz; Duty Cycle: 1:1  
Medium: Muscle 1800 MHz Medium parameters used:  $f = 1750$  MHz;  $\sigma = 1.473$  S/m;  $\epsilon_r = 53.953$ ;  $\rho = 1000$  kg/m<sup>3</sup>  
Phantom section: Flat Section

Measurement Standard: DASY5 (IEEE/IEC/ANSI C63.19-2007)

**DASY5.2 Configuration:**

- Probe: EX3DV4 - SN3893; ConvF(8.66, 8.66, 8.66); Calibrated: 2018-09-20;
- Sensor-Surface: 4mm (Mechanical Surface Detection)
- Electronics: DAE3 Sn522; Calibrated: 2018-09-17
- Phantom: Flat Phantom ELI4.0; Type: QDOVA001BB; Serial: SN:1013
- Measurement SW: DASY52, Version 52.8 (6); SEMCAD X Version 14.6.9 (7117)

**System Performance Check at Frequencies above 1 GHz/d=10mm, Pin=250 mW, dist=4.0mm (EX-Probe)/Area Scan (7x9x1):** Measurement grid: dx=15mm, dy=15mm  
Maximum value of SAR (measured) = 8.14 W/kg

**System Performance Check at Frequencies above 1 GHz/d=10mm, Pin=250 mW, dist=4.0mm (EX-Probe)/Zoom Scan (7x7x7) (7x7x7)/Cube 0:** Measurement grid: dx=5mm, dy=5mm, dz=5mm  
Reference Value = 83.457 V/m; Power Drift = 0.03 dB  
Peak SAR (extrapolated) = 17.1 W/kg  
**SAR(1 g) = 9.35 W/kg; SAR(10 g) = 4.93 W/kg**  
Maximum value of SAR (measured) = 10.5 W/kg

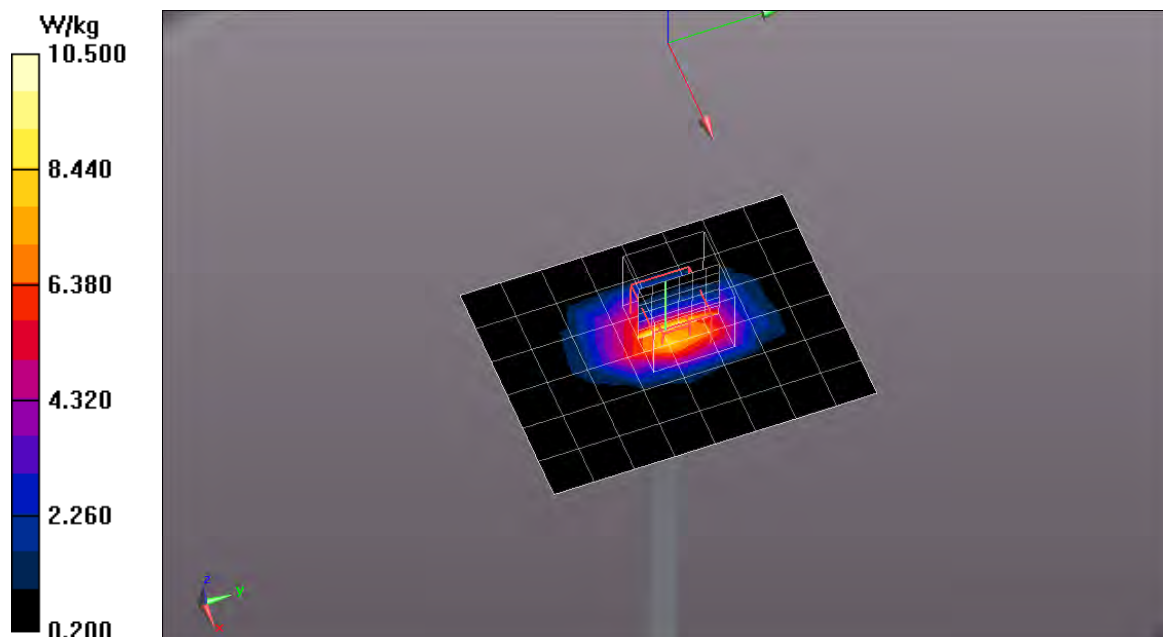

**Test Laboratory: Eurofins Product Service GmbH**

**Dipol Valid.1750 (m)\_250mW ELI4\_22.05.2019**

**DUT: Dipole 1750 MHz (D1750V2); Type: SA AAD 175 AA; Serial: 1126**

Communication System: UID 0 - n/a, CW; Frequency: 1750 MHz; Duty Cycle: 1:1  
Medium: Muscle 1800 MHz Medium parameters used:  $f = 1750$  MHz;  $\sigma = 1.473$  S/m;  $\epsilon_r = 53.953$ ;  $\rho = 1000$  kg/m<sup>3</sup>  
Phantom section: Flat Section

Measurement Standard: DASYS (IEEE/IEC/ANSI C63.19-2007)

**DASY5.2 Configuration:**

- Probe: EX3DV4 - SN3893; ConvF(8.66, 8.66, 8.66); Calibrated: 2018-09-20;
- Sensor-Surface: 4mm (Mechanical Surface Detection)
- Electronics: DAE3 Sn522; Calibrated: 2018-09-17
- Phantom: Flat Phantom ELI4.0; Type: QDOVA001BB; Serial: SN:1013
- Measurement SW: DASYS2, Version 52.8 (6); SEMCAD X Version 14.6.9 (7117)

**System Performance Check at Frequencies above 1 GHz/d=10mm, Pin=250 mW, dist=4.0mm (EX-Probe)/Area Scan (7x9x1):** Measurement grid: dx=15mm, dy=15mm  
Maximum value of SAR (measured) = 7.44 W/kg

**System Performance Check at Frequencies above 1 GHz/d=10mm, Pin=250 mW, dist=4.0mm (EX-Probe)/Zoom Scan (7x7x7) (7x7x7)/Cube 0:** Measurement grid: dx=5mm, dy=5mm, dz=5mm  
Reference Value = 82.540 V/m; Power Drift = 0.09 dB  
Peak SAR (extrapolated) = 17.1 W/kg  
**SAR(1 g) = 9.3 W/kg; SAR(10 g) = 4.9 W/kg**  
Maximum value of SAR (measured) = 10.4 W/kg

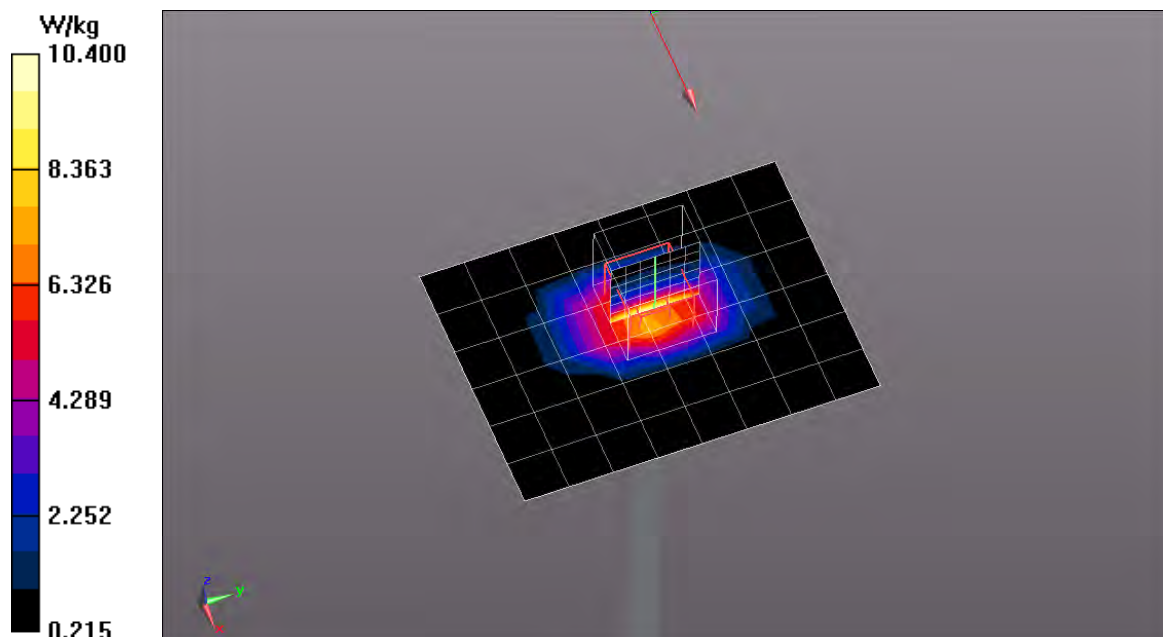



**Test Laboratory: Eurofins Product Service GmbH**

**Dipol Valid.750 (m)\_250mW ELI4\_23.05.2019**

**DUT: Dipole 750 MHz; Type: D750V3; Serial: 1125**

Communication System: UID 0 - n/a, CW; Frequency: 750 MHz; Duty Cycle: 1:1  
Medium: Muscle 750 MHz Medium parameters used:  $f = 750 \text{ MHz}$ ;  $\sigma = 0.986 \text{ S/m}$ ;  $\epsilon_r = 54.145$ ;  $\rho = 1000 \text{ kg/m}^3$   
Phantom section: Flat Section

Measurement Standard: DASYS (IEEE/IEC/ANSI C63.19-2007)

**DASY5.2 Configuration:**

- Probe: EX3DV4 - SN3893; ConvF(10.54, 10.54, 10.54); Calibrated: 2018-09-20;
- Sensor-Surface: 4mm (Mechanical Surface Detection), Sensor-Surface: 2mm (Mechanical Surface Detection)
- Electronics: DAE3 Sn522; Calibrated: 2018-09-17
- Phantom: Flat Phantom ELI4.0; Type: QDOVA001BB; Serial: SN:1013
- Measurement SW: DASYS2, Version 52.8 (6); SEMCAD X Version 14.6.9 (7117)

**System Performance Check at Frequencies below 1 GHz/d=15mm, Pin=250 mW, dist=4.0mm (EX-Probe)/Area Scan (7x9x1):** Measurement grid: dx=15mm, dy=15mm  
Maximum value of SAR (measured) = 2.10 W/kg

**System Performance Check at Frequencies below 1 GHz/d=15mm, Pin=250 mW, dist=4.0mm (EX-Probe)/Zoom Scan (7x7x7) (7x7x7)/Cube 0:** Measurement grid: dx=5mm, dy=5mm, dz=5mm  
Reference Value = 53.749 V/m; Power Drift = 0.00 dB  
Peak SAR (extrapolated) = 3.25 W/kg  
**SAR(1 g) = 2.2 W/kg; SAR(10 g) = 1.47 W/kg**  
Maximum value of SAR (measured) = 2.78 W/kg

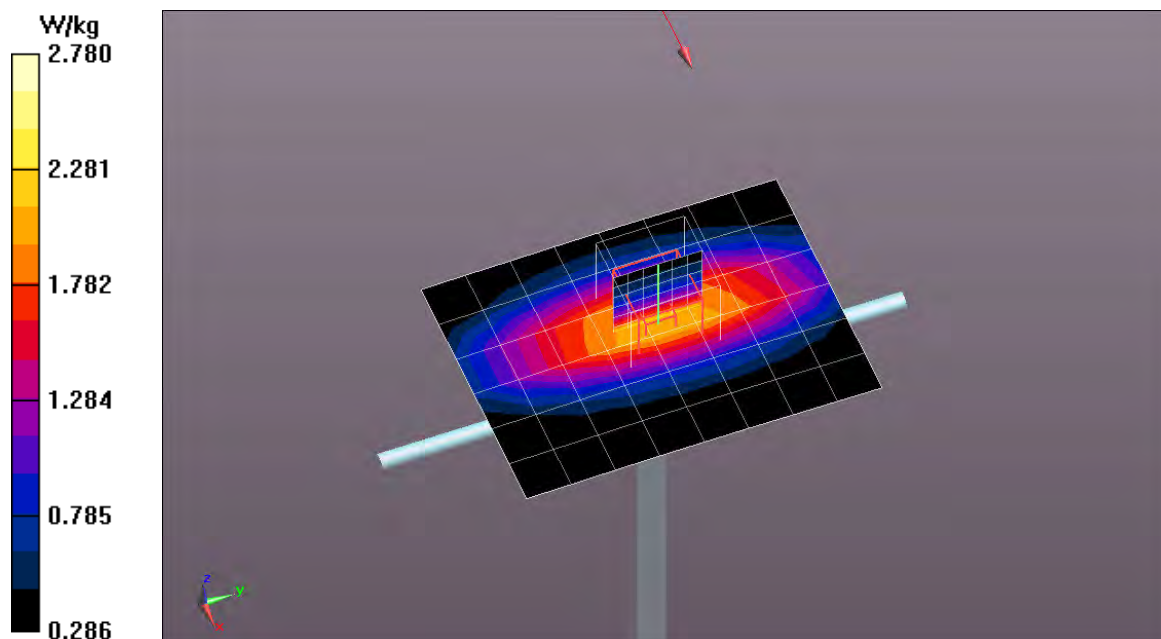

**Test Laboratory: Eurofins Product Service GmbH**

**Dipol Valid.1900 (m)\_250mW ELI4\_28.05.2019**

**DUT: Dipole 1900 MHz; Type: D1900V2; Serial: 5d025**

Communication System: UID 0 - n/a, CW; Frequency: 1900 MHz; Duty Cycle: 1:1  
Medium: Muscle 1900 MHz Medium parameters used (interpolated):  $f = 1900$  MHz;  $\sigma = 1.532$  S/m;  $\epsilon_r = 53.277$ ;  $\rho = 1000$  kg/m<sup>3</sup>  
Phantom section: Flat Section

Measurement Standard: DASYS (IEEE/IEC/ANSI C63.19-2007)

**DASY5.2 Configuration:**

- Probe: EX3DV4 - SN3893; ConvF(8.47, 8.47, 8.47); Calibrated: 2018-09-20;
- Sensor-Surface: 4mm (Mechanical Surface Detection)
- Electronics: DAE3 Sn522; Calibrated: 2018-09-17
- Phantom: Flat Phantom ELI4.0; Type: QDOVA001BB; Serial: SN:1013
- Measurement SW: DASY52, Version 52.8 (6); SEMCAD X Version 14.6.9 (7117)

**System Performance Check at Frequencies above 1 GHz/d=10mm, Pin=250 mW, dist=4.0mm (EX-Probe)/Area Scan (7x9x1):** Measurement grid: dx=15mm, dy=15mm  
Maximum value of SAR (measured) = 9.13 W/kg

**System Performance Check at Frequencies above 1 GHz/d=10mm, Pin=250 mW, dist=4.0mm (EX-Probe)/Zoom Scan (7x7x7) (7x7x7)/Cube 0:** Measurement grid: dx=5mm, dy=5mm, dz=5mm  
Reference Value = 86.757 V/m; Power Drift = 0.03 dB  
Peak SAR (extrapolated) = 18.3 W/kg  
**SAR(1 g) = 10.1 W/kg; SAR(10 g) = 5.29 W/kg**  
Maximum value of SAR (measured) = 11.3 W/kg

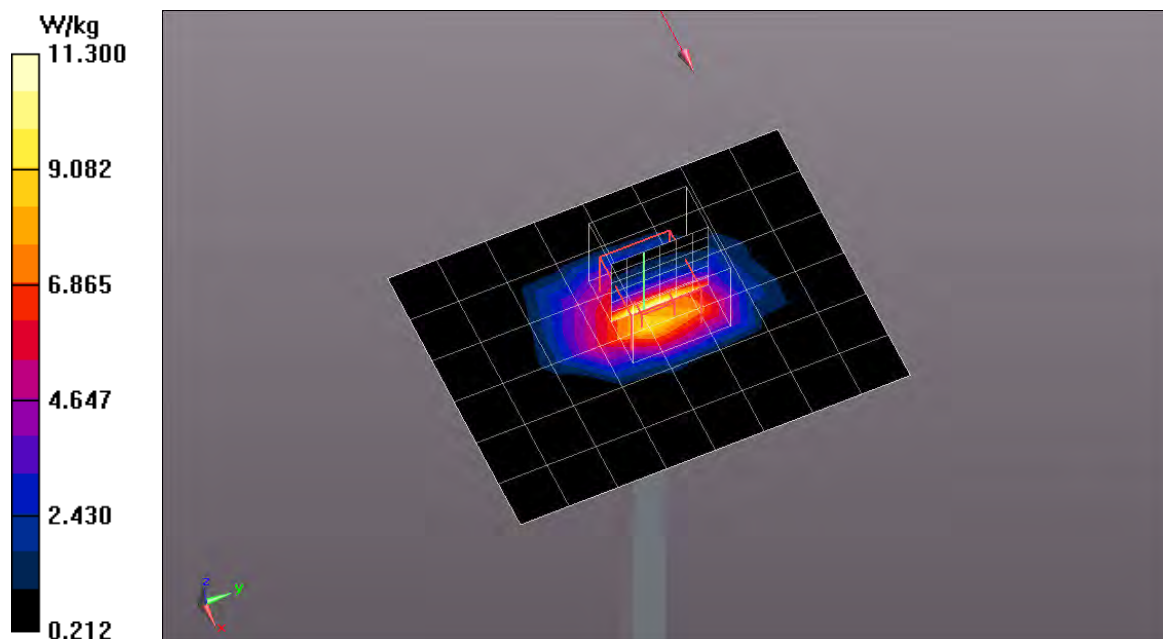

**Test Laboratory: Eurofins Product Service GmbH**

**Dipol Valid.1900 (m)\_250mW ELI4\_29.05.2019**

**DUT: Dipole 1900 MHz; Type: D1900V2; Serial: 5d025**

Communication System: UID 0 - n/a, CW; Frequency: 1900 MHz; Duty Cycle: 1:1  
Medium: Muscle 1900 MHz Medium parameters used (interpolated):  $f = 1900$  MHz;  $\sigma = 1.532$  S/m;  $\epsilon_r = 53.277$ ;  $\rho = 1000$  kg/m<sup>3</sup>  
Phantom section: Flat Section

Measurement Standard: DASYS (IEEE/IEC/ANSI C63.19-2007)

**DASY5.2 Configuration:**

- Probe: EX3DV4 - SN3893; ConvF(8.47, 8.47, 8.47); Calibrated: 2018-09-20;
- Sensor-Surface: 4mm (Mechanical Surface Detection)
- Electronics: DAE3 Sn522; Calibrated: 2018-09-17
- Phantom: Flat Phantom ELI4.0; Type: QDOVA001BB; Serial: SN:1013
- Measurement SW: DASY52, Version 52.8 (6); SEMCAD X Version 14.6.9 (7117)

**System Performance Check at Frequencies above 1 GHz/d=10mm, Pin=250 mW, dist=4.0mm (EX-Probe)/Area Scan (7x9x1):** Measurement grid: dx=15mm, dy=15mm  
Maximum value of SAR (measured) = 10.3 W/kg

**System Performance Check at Frequencies above 1 GHz/d=10mm, Pin=250 mW, dist=4.0mm (EX-Probe)/Zoom Scan (7x7x7) (7x7x7)/Cube 0:** Measurement grid: dx=5mm, dy=5mm, dz=5mm  
Reference Value = 87.176 V/m; Power Drift = -0.00 dB  
Peak SAR (extrapolated) = 18.7 W/kg  
**SAR(1 g) = 10.3 W/kg; SAR(10 g) = 5.37 W/kg**  
Maximum value of SAR (measured) = 11.5 W/kg

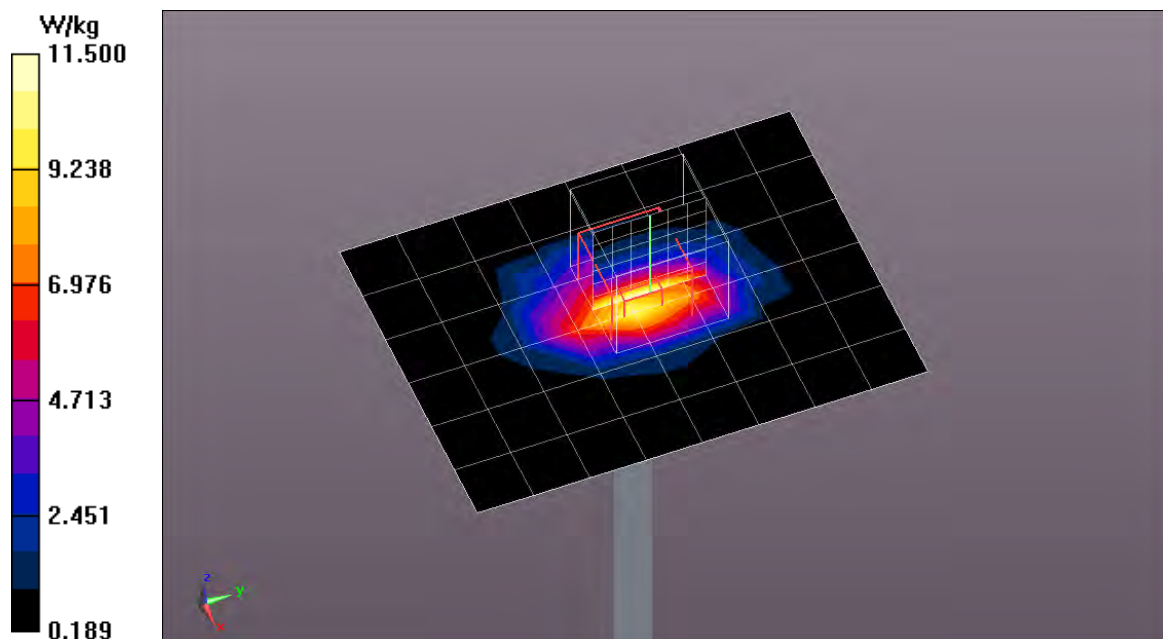



**ANNEX C SAR Measurement Reports**

**Test Laboratory: Eurofins Product Service GmbH**

**LTE-FDD2\_Cat-M1 CH18700 eMTC QPSK BW20 RB1 Start0 NB0\_Flat Right 0mm**

**DUT: CardioMessenger Smart 4G; Type: Handheld; Serial: 80100206**

Communication System: UID 0 - n/a, LTE FDD 2 Cat-M1; Frequency: 1860 MHz; Duty Cycle: 1:3.33043  
Medium: Muscle 1900 MHz Medium parameters used (interpolated):  $f = 1860$  MHz;  $\sigma = 1.503$  S/m;  $\epsilon_r = 53.538$ ;  $\rho = 1000$  kg/m<sup>3</sup>  
Phantom section: Flat Section

Measurement Standard: DASYS (IEEE/IEC/ANSI C63.19-2007)

**DASY5.2 Configuration:**

- Probe: EX3DV4 - SN3893; ConvF(8.47, 8.47, 8.47); Calibrated: 2018-09-20;
- Sensor-Surface: 4mm (Mechanical Surface Detection)
- Electronics: DAE3 Sn522; Calibrated: 2018-09-17
- Phantom: Flat Phantom ELI4.0; Type: QDOVA001BB; Serial: SN:1013
- Measurement SW: DASYS2, Version 52.8 (6); SEMCAD X Version 14.6.9 (7117)

**Configuration/CM Smart 4G/Area Scan (6x16x1):** Measurement grid: dx=12mm, dy=12mm  
Maximum value of SAR (measured) = 0.693 W/kg

**Configuration/CM Smart 4G/Zoom Scan (7x7x7)/Cube 0:** Measurement grid: dx=5mm, dy=5mm, dz=5mm  
Reference Value = 23.067 V/m; Power Drift = 0.19 dB  
Peak SAR (extrapolated) = 1.22 W/kg  
**SAR(1 g) = 0.728 W/kg; SAR(10 g) = 0.411 W/kg**  
Maximum value of SAR (measured) = 0.815 W/kg

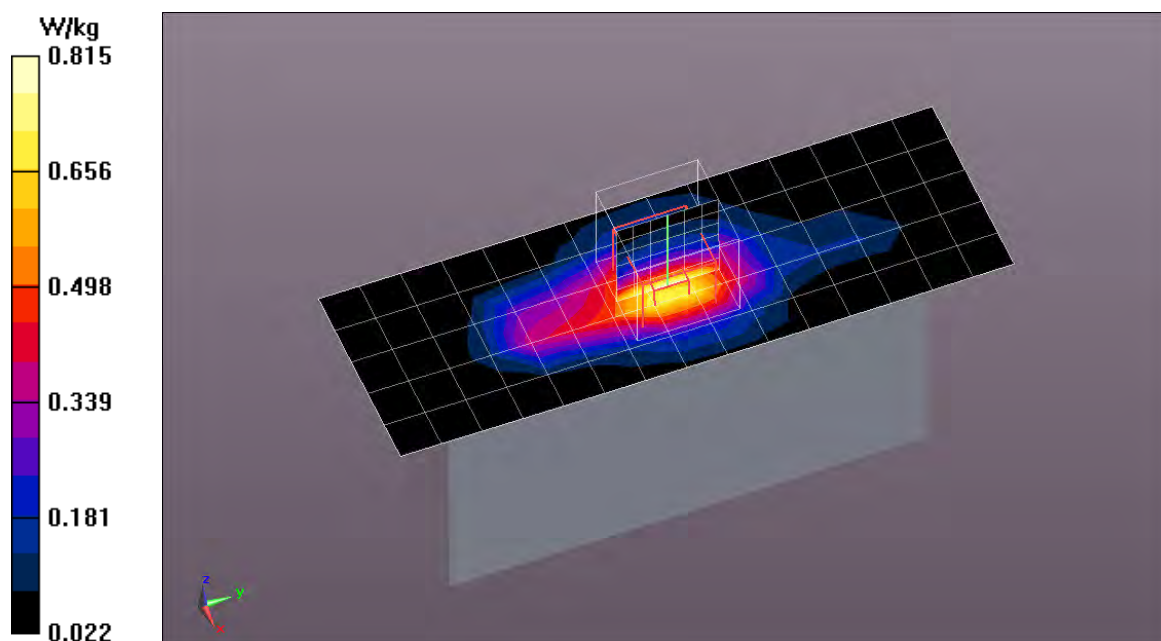

**Test Laboratory: Eurofins Product Service GmbH**

**LTE-FDD2\_Cat-M1 CH18700 eMTC QPSK BW20 RB3 Start0 NB0\_Flat Right 0mm**

**DUT: CardioMessenger Smart 4G; Type: Handheld; Serial: 80100206**

Communication System: UID 0 - n/a, LTE FDD 2 Cat-M1; Frequency: 1860 MHz; Duty Cycle: 1:3.33043  
Medium: Muscle 1900 MHz Medium parameters used (interpolated):  $f = 1860$  MHz;  $\sigma = 1.503$  S/m;  $\epsilon_r = 53.538$ ;  $\rho = 1000$  kg/m<sup>3</sup>  
Phantom section: Flat Section

Measurement Standard: DASYS (IEEE/IEC/ANSI C63.19-2007)

**DASY5.2 Configuration:**

- Probe: EX3DV4 - SN3893; ConvF(8.47, 8.47, 8.47); Calibrated: 2018-09-20;
- Sensor-Surface: 4mm (Mechanical Surface Detection)
- Electronics: DAE3 Sn522; Calibrated: 2018-09-17
- Phantom: Flat Phantom ELI4.0; Type: QDOVA001BB; Serial: SN:1013
- Measurement SW: DASYS2, Version 52.8 (6); SEMCAD X Version 14.6.9 (7117)

**Configuration/CM Smart 4G/Area Scan (6x16x1):** Measurement grid: dx=12mm, dy=12mm  
Maximum value of SAR (measured) = 0.696 W/kg

**Configuration/CM Smart 4G/Zoom Scan (7x7x7)/Cube 0:** Measurement grid: dx=5mm, dy=5mm, dz=5mm  
Reference Value = 23.302 V/m; Power Drift = -0.00 dB  
Peak SAR (extrapolated) = 1.26 W/kg  
**SAR(1 g) = 0.748 W/kg; SAR(10 g) = 0.422 W/kg**  
Maximum value of SAR (measured) = 0.830 W/kg

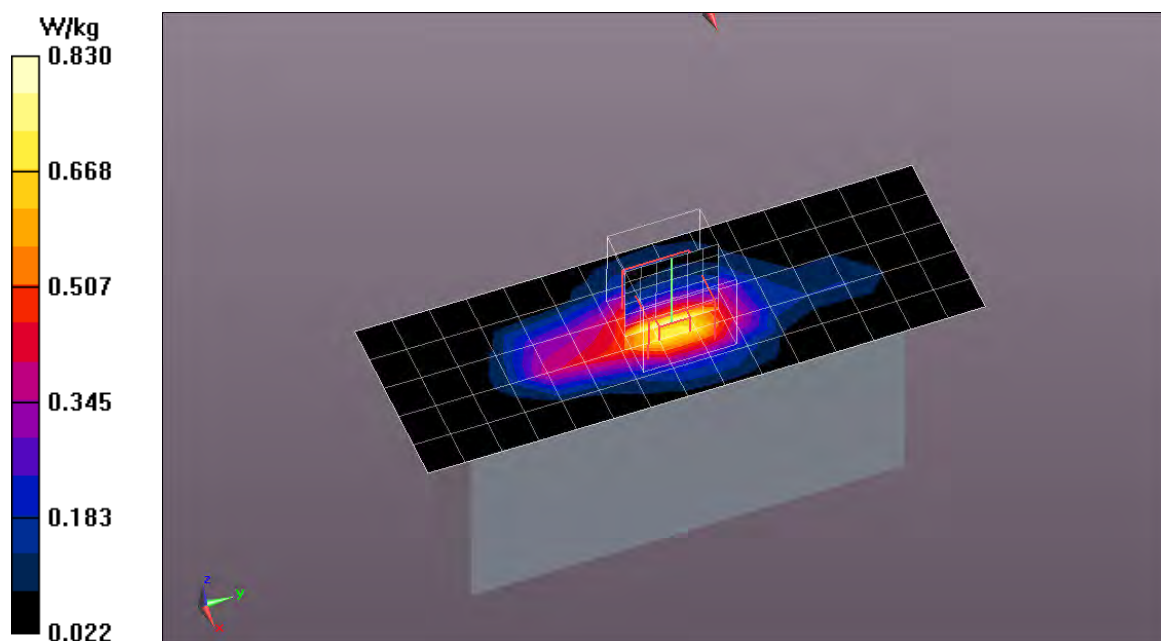



**Test Laboratory: Eurofins Product Service GmbH**

**LTE-FDD2\_Cat-M1 CH18700 eMTC QPSK BW20 RB6 Start0 NB0\_Flat Right 0mm**

**DUT: CardioMessenger Smart 4G; Type: Handheld; Serial: 80100206**

Communication System: UID 0 - n/a, LTE FDD 2 Cat-M1; Frequency: 1860 MHz; Duty Cycle: 1:3.33043  
Medium: Muscle 1900 MHz Medium parameters used (interpolated):  $f = 1860$  MHz;  $\sigma = 1.503$  S/m;  $\epsilon_r = 53.538$ ;  $\rho = 1000$  kg/m<sup>3</sup>  
Phantom section: Flat Section

Measurement Standard: DASY5 (IEEE/IEC/ANSI C63.19-2007)

**DASY5.2 Configuration:**

- Probe: EX3DV4 - SN3893; ConvF(8.47, 8.47, 8.47); Calibrated: 2018-09-20;
- Sensor-Surface: 4mm (Mechanical Surface Detection)
- Electronics: DAE3 Sn522; Calibrated: 2018-09-17
- Phantom: Flat Phantom ELI4.0; Type: QDOVA001BB; Serial: SN:1013
- Measurement SW: DASY52, Version 52.8 (6); SEMCAD X Version 14.6.9 (7117)

**Configuration/CM Smart 4G/Area Scan (6x16x1):** Measurement grid: dx=12mm, dy=12mm  
Maximum value of SAR (measured) = 0.714 W/kg

**Configuration/CM Smart 4G/Zoom Scan (7x7x7)/Cube 0:** Measurement grid: dx=5mm, dy=5mm, dz=5mm  
Reference Value = 23.383 V/m; Power Drift = -0.17 dB  
Peak SAR (extrapolated) = 1.20 W/kg  
**SAR(1 g) = 0.724 W/kg; SAR(10 g) = 0.411 W/kg**  
Maximum value of SAR (measured) = 0.802 W/kg

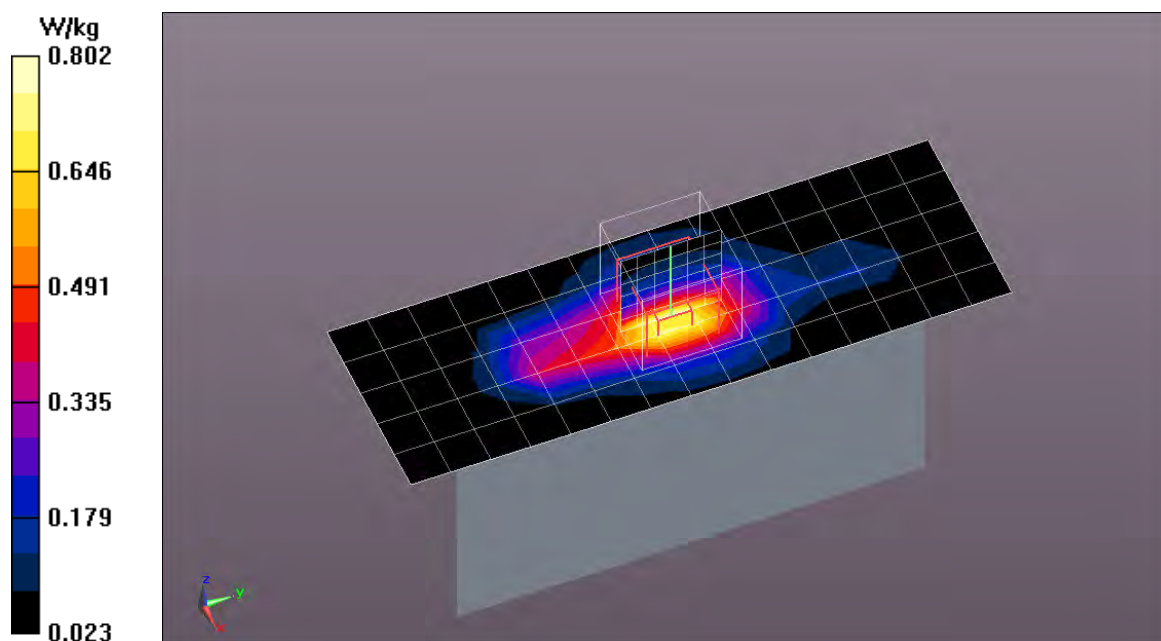

**Test Laboratory: Eurofins Product Service GmbH**

**LTE-FDD2\_Cat-M1 CH19100 eMTC 16-QAM BW20 RB1 Start0 NB0\_Flat Right 0mm**

**DUT: CardioMessenger Smart 4G; Type: Handheld; Serial: 80100206**

Communication System: UID 0 - n/a, LTE FDD 2 Cat-M1; Frequency: 1900 MHz; Duty Cycle: 1:3.33043  
Medium: Muscle 1900 MHz Medium parameters used (interpolated):  $f = 1900$  MHz;  $\sigma = 1.532$  S/m;  $\epsilon_r = 53.277$ ;  $\rho = 1000$  kg/m<sup>3</sup>  
Phantom section: Flat Section

Measurement Standard: DASYS (IEEE/IEC/ANSI C63.19-2007)

**DASY5.2 Configuration:**

- Probe: EX3DV4 - SN3893; ConvF(8.47, 8.47, 8.47); Calibrated: 2018-09-20;
- Sensor-Surface: 4mm (Mechanical Surface Detection)
- Electronics: DAE3 Sn522; Calibrated: 2018-09-17
- Phantom: Flat Phantom ELI4.0; Type: QDOVA001BB; Serial: SN:1013
- Measurement SW: DASYS2, Version 52.8 (6); SEMCAD X Version 14.6.9 (7117)

**Configuration/CM Smart 4G/Area Scan (6x16x1):** Measurement grid: dx=12mm, dy=12mm  
Maximum value of SAR (measured) = 0.553 W/kg

**Configuration/CM Smart 4G/Zoom Scan (7x7x7)/Cube 0:** Measurement grid: dx=5mm, dy=5mm, dz=5mm  
Reference Value = 19.784 V/m; Power Drift = -0.03 dB  
Peak SAR (extrapolated) = 0.942 W/kg  
**SAR(1 g) = 0.556 W/kg; SAR(10 g) = 0.312 W/kg**  
Maximum value of SAR (measured) = 0.619 W/kg

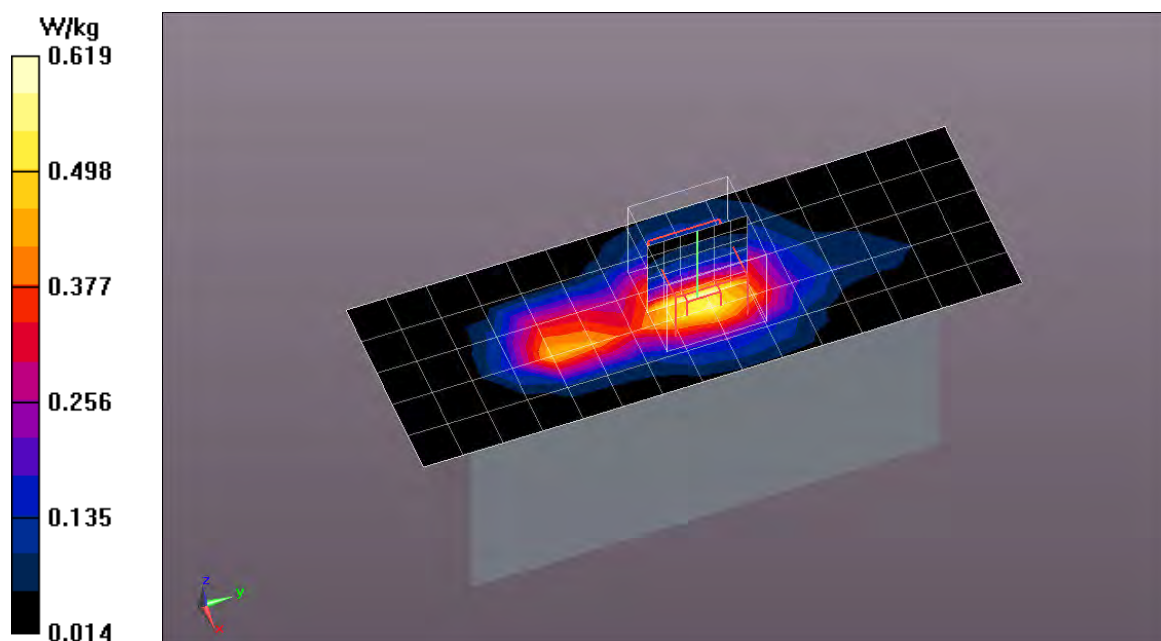

**Test Laboratory: Eurofins Product Service GmbH**

**LTE-FDD12\_Cat-M1 CH23060 eMTC QPSK BW10 RB1 Start0 NB0\_Flat Right 0mm**

**DUT: CardioMessenger Smart 4G; Type: Handheld; Serial: 80100206**

Communication System: UID 0 - n/a, LTE FDD 12 Cat-M1; Frequency: 704 MHz; Duty Cycle: 1:3.33043  
Medium: Muscle 750 MHz Medium parameters used (interpolated):  $f = 704$  MHz;  $\sigma = 0.941$  S/m;  $\epsilon_r = 54.624$ ;  $\rho = 1000$  kg/m<sup>3</sup>  
Phantom section: Flat Section

Measurement Standard: DASY5 (IEEE/IEC/ANSI C63.19-2007)

**DASY5.2 Configuration:**

- Probe: EX3DV4 - SN3893; ConvF(10.54, 10.54, 10.54); Calibrated: 2018-09-20;
- Sensor-Surface: 4mm (Mechanical Surface Detection)
- Electronics: DAE3 Sn522; Calibrated: 2018-09-17
- Phantom: Flat Phantom ELI4.0; Type: QDOVA001BB; Serial: SN:1013
- Measurement SW: DASY52, Version 52.8 (6); SEMCAD X Version 14.6.9 (7117)

**Configuration/CM Smart 4G/Area Scan (5x13x1):** Measurement grid: dx=15mm, dy=15mm  
Maximum value of SAR (measured) = 0.422 W/kg

**Configuration/CM Smart 4G/Zoom Scan (7x7x7)/Cube 0:** Measurement grid: dx=5mm, dy=5mm, dz=5mm  
Reference Value = 19.625 V/m; Power Drift = -0.02 dB  
Peak SAR (extrapolated) = 0.603 W/kg  
**SAR(1 g) = 0.405 W/kg; SAR(10 g) = 0.272 W/kg**  
Maximum value of SAR (measured) = 0.445 W/kg

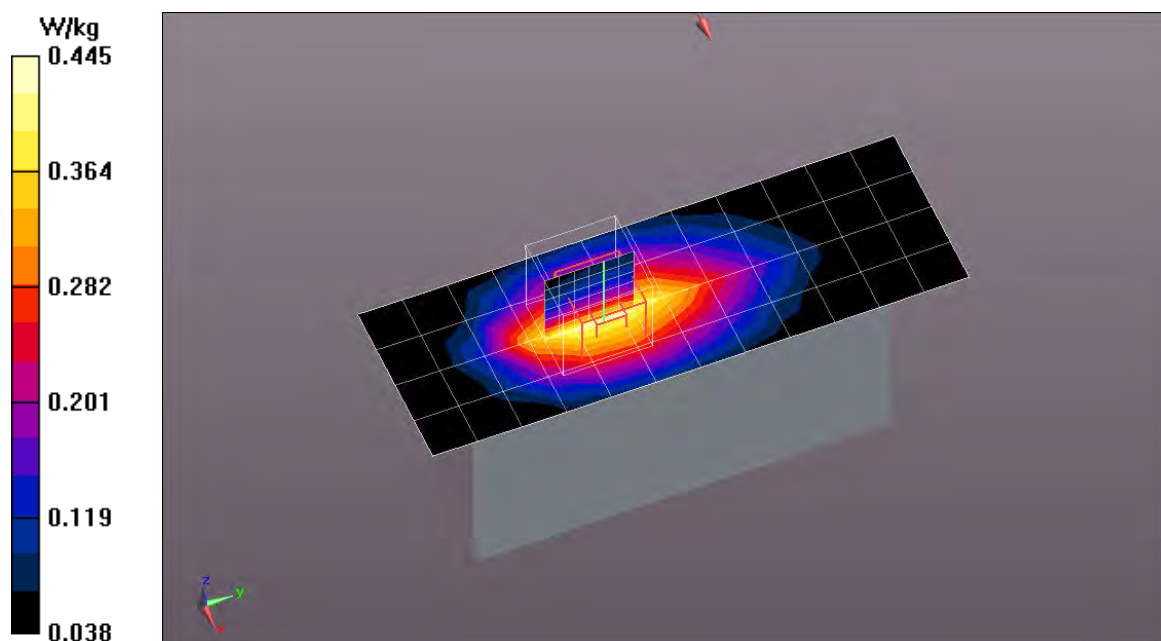



**Test Laboratory: Eurofins Product Service GmbH**

**LTE-FDD12\_Cat-M1 CH23130 eMTC QPSK BW10 RB3 Start0 NB4\_Flat Right 0mm**

**DUT: CardioMessenger Smart 4G; Type: Handheld; Serial: 80100206**

Communication System: UID 0 - n/a, LTE FDD 12 Cat-M1; Frequency: 711 MHz; Duty Cycle: 1:3.33043  
Medium: Muscle 750 MHz Medium parameters used (interpolated):  $f = 711$  MHz;  $\sigma = 0.947$  S/m;  $\epsilon_r = 54.535$ ;  $\rho = 1000$  kg/m<sup>3</sup>  
Phantom section: Flat Section

Measurement Standard: DASY5 (IEEE/IEC/ANSI C63.19-2007)

**DASY5.2 Configuration:**

- Probe: EX3DV4 - SN3893; ConvF(10.54, 10.54, 10.54); Calibrated: 2018-09-20;
- Sensor-Surface: 4mm (Mechanical Surface Detection)
- Electronics: DAE3 Sn522; Calibrated: 2018-09-17
- Phantom: Flat Phantom ELI4.0; Type: QDOVA001BB; Serial: SN:1013
- Measurement SW: DASY52, Version 52.8 (6); SEMCAD X Version 14.6.9 (7117)

**Configuration/CM Smart 4G/Area Scan (5x13x1):** Measurement grid: dx=15mm, dy=15mm  
Maximum value of SAR (measured) = 0.442 W/kg

**Configuration/CM Smart 4G/Zoom Scan (7x7x7)/Cube 0:** Measurement grid: dx=5mm, dy=5mm, dz=5mm  
Reference Value = 20.126 V/m; Power Drift = -0.07 dB  
Peak SAR (extrapolated) = 0.613 W/kg  
**SAR(1 g) = 0.413 W/kg; SAR(10 g) = 0.276 W/kg**  
Maximum value of SAR (measured) = 0.446 W/kg

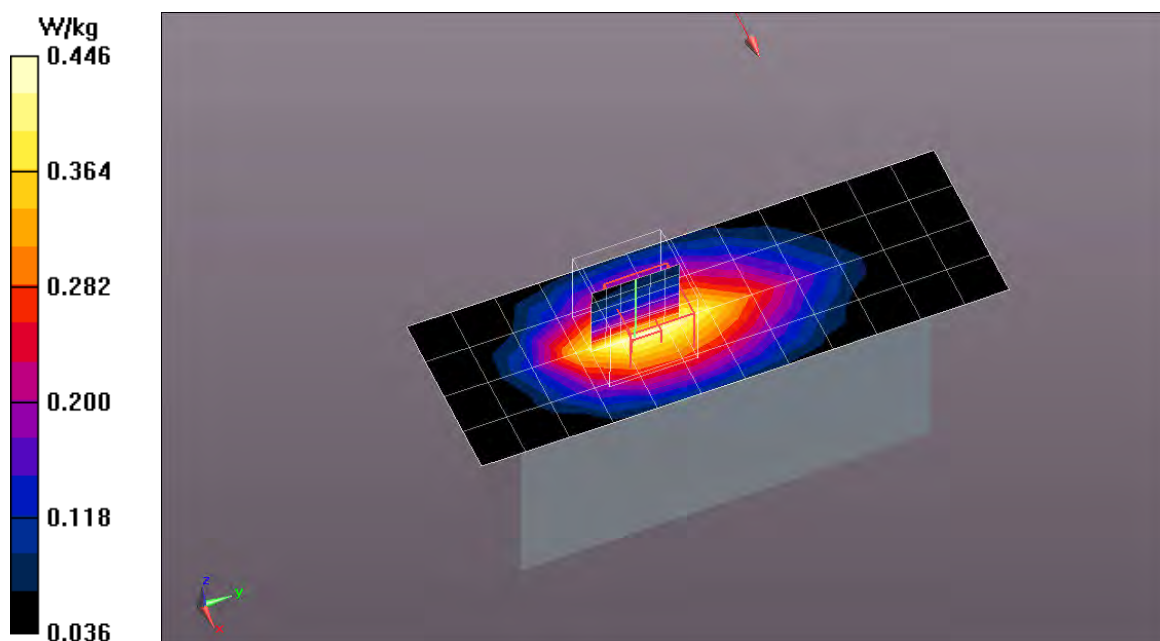

**Test Laboratory: Eurofins Product Service GmbH**

**LTE-FDD12\_Cat-M1 CH23060 eMTC 16-QAM BW10 RB1 Start0 NB0\_Flat Right 0mm**

**DUT: CardioMessenger Smart 4G; Type: Handheld; Serial: 80100206**

Communication System: UID 0 - n/a, LTE FDD 12 Cat-M1; Frequency: 704 MHz; Duty Cycle: 1:3.33043  
Medium: Muscle 750 MHz Medium parameters used (interpolated):  $f = 704$  MHz;  $\sigma = 0.941$  S/m;  $\epsilon_r = 54.624$ ;  $\rho = 1000$  kg/m<sup>3</sup>  
Phantom section: Flat Section

Measurement Standard: DASY5 (IEEE/IEC/ANSI C63.19-2007)

**DASY5.2 Configuration:**

- Probe: EX3DV4 - SN3893; ConvF(10.54, 10.54, 10.54); Calibrated: 2018-09-20;
- Sensor-Surface: 4mm (Mechanical Surface Detection)
- Electronics: DAE3 Sn522; Calibrated: 2018-09-17
- Phantom: Flat Phantom ELI4.0; Type: QDOVA001BB; Serial: SN:1013
- Measurement SW: DASY52, Version 52.8 (6); SEMCAD X Version 14.6.9 (7117)

**Configuration/CM Smart 4G/Area Scan (5x13x1):** Measurement grid: dx=15mm, dy=15mm  
Maximum value of SAR (measured) = 0.417 W/kg

**Configuration/CM Smart 4G/Zoom Scan (7x7x7)/Cube 0:** Measurement grid: dx=5mm, dy=5mm, dz=5mm  
Reference Value = 19.065 V/m; Power Drift = 0.06 dB  
Peak SAR (extrapolated) = 0.585 W/kg  
**SAR(1 g) = 0.396 W/kg; SAR(10 g) = 0.264 W/kg**  
Maximum value of SAR (measured) = 0.426 W/kg

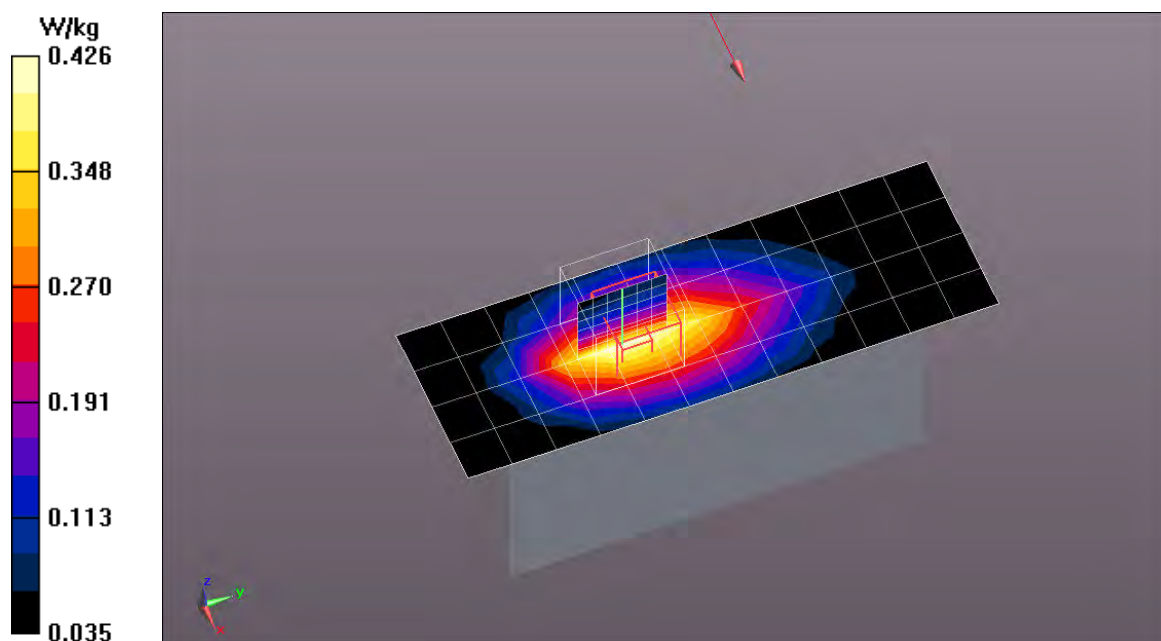

**Test Laboratory: Eurofins Product Service GmbH**

**LTE-FDD4\_Cat-M1 CH20300 eMTC QPSK BW20 RB1 Start5 NB15\_Flat Right 0mm**

**DUT: CardioMessenger Smart 4G; Type: Handheld; Serial: 80100206**

Communication System: UID 0 - n/a, LTE FDD 4 Cat-M1; Frequency: 1745 MHz; Duty Cycle: 1:3.33043  
Medium: Muscle 1800 MHz Medium parameters used (interpolated):  $f = 1745$  MHz;  $\sigma = 1.467$  S/m;  $\epsilon_r = 53.975$ ;  $\rho = 1000$  kg/m<sup>3</sup>  
Phantom section: Flat Section

Measurement Standard: DASY5 (IEEE/IEC/ANSI C63.19-2007)

**DASY5.2 Configuration:**

- Probe: EX3DV4 - SN3893; ConvF(8.66, 8.66, 8.66); Calibrated: 2018-09-20;
- Sensor-Surface: 4mm (Mechanical Surface Detection)
- Electronics: DAE3 Sn522; Calibrated: 2018-09-17
- Phantom: Flat Phantom ELI4.0; Type: QDOVA001BB; Serial: SN:1013
- Measurement SW: DASY52, Version 52.8 (6); SEMCAD X Version 14.6.9 (7117)

**Configuration/CM Smart 4G/Area Scan (7x19x1):** Measurement grid: dx=10mm, dy=10mm  
Maximum value of SAR (measured) = 0.705 W/kg

**Configuration/CM Smart 4G/Zoom Scan (7x7x7)/Cube 0:** Measurement grid: dx=5mm, dy=5mm, dz=5mm  
Reference Value = 20.713 V/m; Power Drift = -0.02 dB  
Peak SAR (extrapolated) = 1.11 W/kg  
**SAR(1 g) = 0.635 W/kg; SAR(10 g) = 0.360 W/kg**  
Maximum value of SAR (measured) = 0.706 W/kg

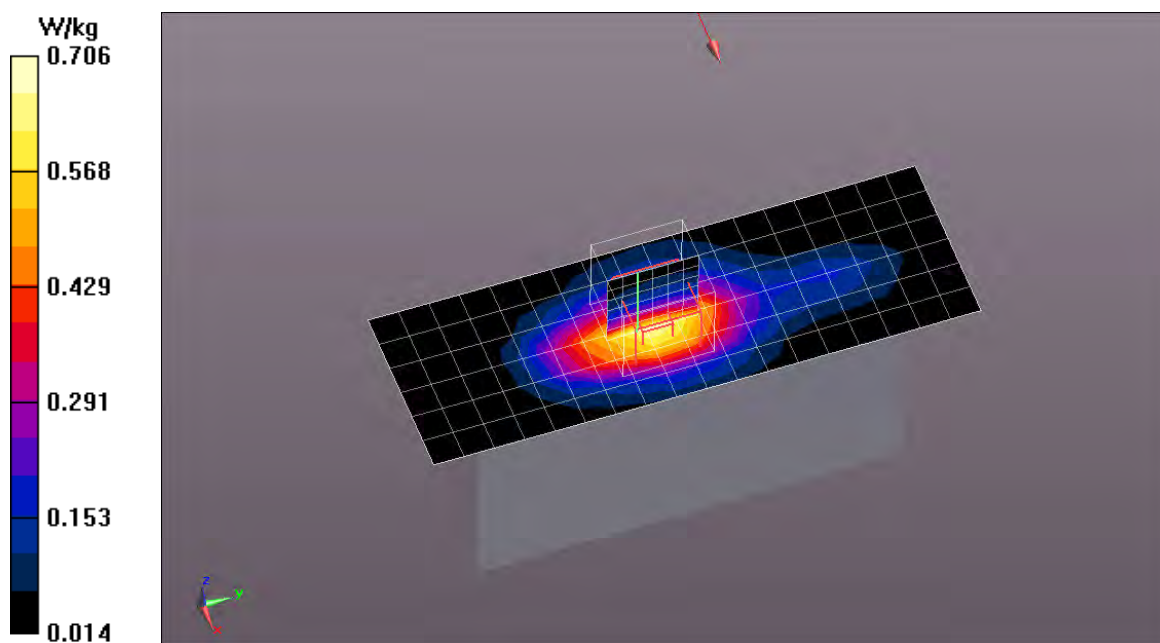

**Test Laboratory: Eurofins Product Service GmbH**

**LTE-FDD4\_Cat-M1 CH20175 eMTC QPSK BW20 RB3 Start3 NB15\_Flat Right 0mm**

**DUT: CardioMessenger Smart 4G; Type: Handheld; Serial: 80100206**

Communication System: UID 0 - n/a, LTE FDD 4 Cat-M1; Frequency: 1732.5 MHz; Duty Cycle: 1:3.33043  
Medium: Muscle 1800 MHz Medium parameters used (interpolated):  $f = 1732.5$  MHz;  $\sigma = 1.451$  S/m;  $\epsilon_r = 54.024$ ;  $\rho = 1000$  kg/m<sup>3</sup>  
Phantom section: Flat Section

Measurement Standard: DASYS (IEEE/IEC/ANSI C63.19-2007)

**DASY5.2 Configuration:**

- Probe: EX3DV4 - SN3893; ConvF(8.66, 8.66, 8.66); Calibrated: 2018-09-20;
- Sensor-Surface: 4mm (Mechanical Surface Detection)
- Electronics: DAE3 Sn522; Calibrated: 2018-09-17
- Phantom: Flat Phantom ELI4.0; Type: QDOVA001BB; Serial: SN:1013
- Measurement SW: DASYS2, Version 52.8 (6); SEMCAD X Version 14.6.9 (7117)

**Configuration/CM Smart 4G/Area Scan (5x13x1):** Measurement grid: dx=10mm, dy=10mm  
Maximum value of SAR (measured) = 0.733 W/kg

**Configuration/CM Smart 4G/Zoom Scan (7x7x7)/Cube 0:** Measurement grid: dx=5mm, dy=5mm, dz=5mm  
Reference Value = 22.479 V/m; Power Drift = -0.01 dB  
Peak SAR (extrapolated) = 1.23 W/kg  
**SAR(1 g) = 0.727 W/kg; SAR(10 g) = 0.415 W/kg**  
Maximum value of SAR (measured) = 0.814 W/kg

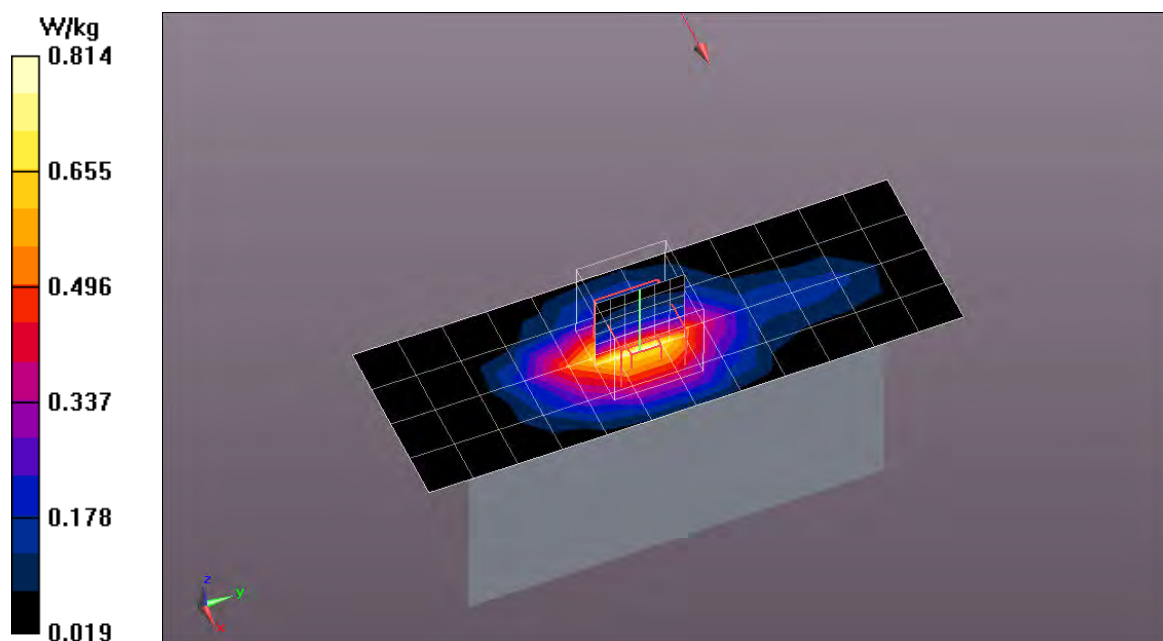



**Test Laboratory: Eurofins Product Service GmbH**

**LTE-FDD4\_Cat-M1 CH20050 eMTC QPSK BW20 RB6 Start0 NB0\_Flat Right 0mm**

**DUT: CardioMessenger Smart 4G; Type: Handheld; Serial: 80100206**

Communication System: UID 0 - n/a, LTE FDD 4 Cat-M1; Frequency: 1720 MHz; Duty Cycle: 1:3.33043  
Medium: Muscle 1800 MHz Medium parameters used:  $f = 1720$  MHz;  $\sigma = 1.435$  S/m;  $\epsilon_r = 54.109$ ;  $\rho = 1000$  kg/m<sup>3</sup>  
Phantom section: Flat Section

Measurement Standard: DASYS (IEEE/IEC/ANSI C63.19-2007)

**DASY5.2 Configuration:**

- Probe: EX3DV4 - SN3893; ConvF(8.66, 8.66, 8.66); Calibrated: 2018-09-20;
- Sensor-Surface: 4mm (Mechanical Surface Detection)
- Electronics: DAE3 Sn522; Calibrated: 2018-09-17
- Phantom: Flat Phantom ELI4.0; Type: QDOVA001BB; Serial: SN:1013
- Measurement SW: DASY52, Version 52.8 (6); SEMCAD X Version 14.6.9 (7117)

**Configuration/CM Smart 4G/Area Scan (5x13x1):** Measurement grid: dx=10mm, dy=10mm  
Maximum value of SAR (measured) = 0.767 W/kg

**Configuration/CM Smart 4G/Zoom Scan (7x7x7)/Cube 0:** Measurement grid: dx=5mm, dy=5mm, dz=5mm  
Reference Value = 22.211 V/m; Power Drift = 0.14 dB  
Peak SAR (extrapolated) = 1.26 W/kg  
**SAR(1 g) = 0.751 W/kg; SAR(10 g) = 0.428 W/kg**  
Maximum value of SAR (measured) = 0.821 W/kg

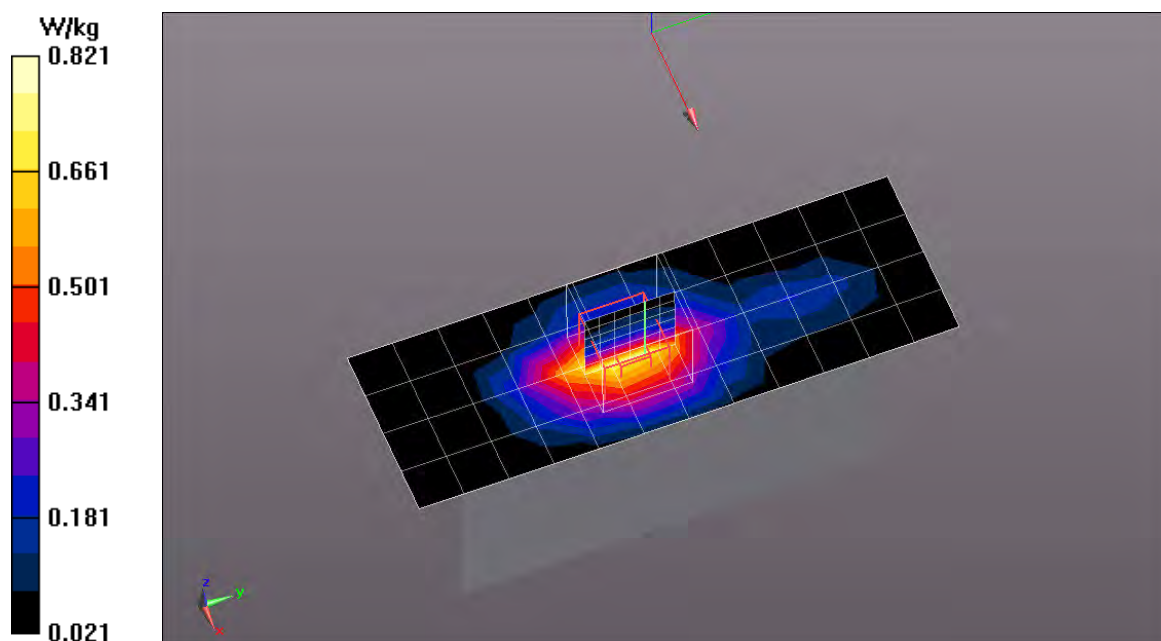

**Test Laboratory: Eurofins Product Service GmbH**

**LTE-FDD4\_Cat-M1 CH20175 eMTC 16-QAM BW20 RB1 Start5 NB15\_Flat Right 0mm**

**DUT: CardioMessenger Smart 4G; Type: Handheld; Serial: 80100206**

Communication System: UID 0 - n/a, LTE FDD 4 Cat-M1; Frequency: 1732.5 MHz; Duty Cycle: 1:3.33043  
Medium: Muscle 1800 MHz Medium parameters used (interpolated):  $f = 1732.5$  MHz;  $\sigma = 1.451$  S/m;  $\epsilon_r = 54.024$ ;  $\rho = 1000$  kg/m<sup>3</sup>  
Phantom section: Flat Section

Measurement Standard: DASYS (IEEE/IEC/ANSI C63.19-2007)

**DASY5.2 Configuration:**

- Probe: EX3DV4 - SN3893; ConvF(8.66, 8.66, 8.66); Calibrated: 2018-09-20;
- Sensor-Surface: 4mm (Mechanical Surface Detection)
- Electronics: DAE3 Sn522; Calibrated: 2018-09-17
- Phantom: Flat Phantom ELI4.0; Type: QDOVA001BB; Serial: SN:1013
- Measurement SW: DASYS2, Version 52.8 (6); SEMCAD X Version 14.6.9 (7117)

**Configuration/CM Smart 4G/Area Scan (7x19x1):** Measurement grid: dx=10mm, dy=10mm  
Maximum value of SAR (measured) = 0.662 W/kg

**Configuration/CM Smart 4G/Zoom Scan (7x7x7)/Cube 0:** Measurement grid: dx=5mm, dy=5mm, dz=5mm  
Reference Value = 20.891 V/m; Power Drift = -0.10 dB  
Peak SAR (extrapolated) = 1.05 W/kg  
**SAR(1 g) = 0.627 W/kg; SAR(10 g) = 0.357 W/kg**  
Maximum value of SAR (measured) = 0.690 W/kg

