

Redwing GPRS G3110

Theory of Operation

Version 1.0

AirLink Communications, Inc.

Proprietary and Confidential

July 18, 2003

Information in this document is subject to change without notice.
© Copyright AirLink Communications, Inc, 1993-2003. All rights reserved.

Please send comments to:

email: pubs@AirLink.com

Fax: 510-226-4299

Phone: 510-226-4200

Post: AirLink Communications, Inc.
Attention: Technical Publications Dept.
472 Kato Terrace
Fremont, CA 94539

Table of Contents

1	Introduction	1
2	Block Diagram	2
3	Description	3
3.1	1902G Modem	3
3.2	Power Input Protection.....	3
3.3	Serial Port Protection and Conversion	3
3.4	LED Drivers	3
3.5	Antenna Connector	3

Redwing GPRS G3110

Theory of Operation

1 Introduction

The GSM/GPRS wireless network combines the world's leading wireless standard—the Global System for Mobile Communications (GSM)—with fast, packet-switched access to data networks such as the Internet. Providing this fast access is the General Packet Radio Service (GPRS).

The AirLink GPRS modems are designed to operate in GSM/GPRS networks. Two data services are available in the GSM/GPRS networks: GPRS, a packet switched connection, and SMS, a short message service..

GPRS

GPRS is an IP-based service that offers fast, packet-switched access to data networks such as the Internet. It is a mobile service that improves the peak-time capacity of a GSM network. GPRS gives packet-switched access over GSM to external data networks with high peak transfer capacity. The main objective of GPRS is to offer access to standard data networks such as TCP/IP. GPRS is a non-voice service designed specifically for transmitting data. It breaks data messages into separate packets for transmission from the mobile device and sends them to destinations in an external network.

Most any Internet-based application or service will run on GPRS. GPRS offers peak throughputs of 40 Kbps (53.6 Kbps raw) Because GPRS capacity is shared among active users in the same coverage area, actual throughputs may vary.

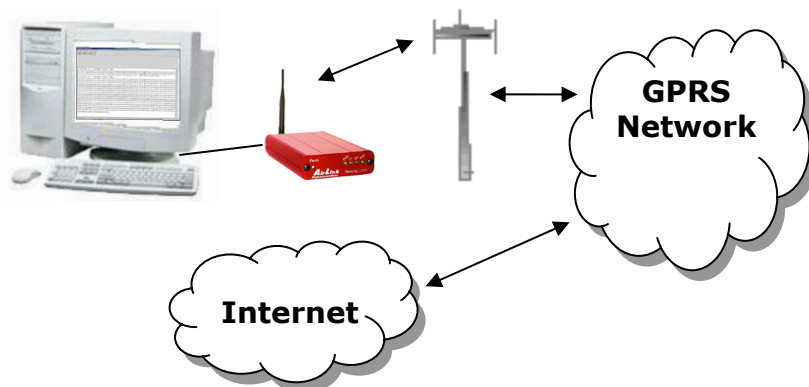

2 Block Diagram

The AirLink Redwing GPRS uses the RIM embedded OEM module, 1902G, to implement the GSM/GPRS modem functions. AirLink mounts the 1902G in a rugged enclosure which provides physical and electrical protection, and a wide range power regulator.

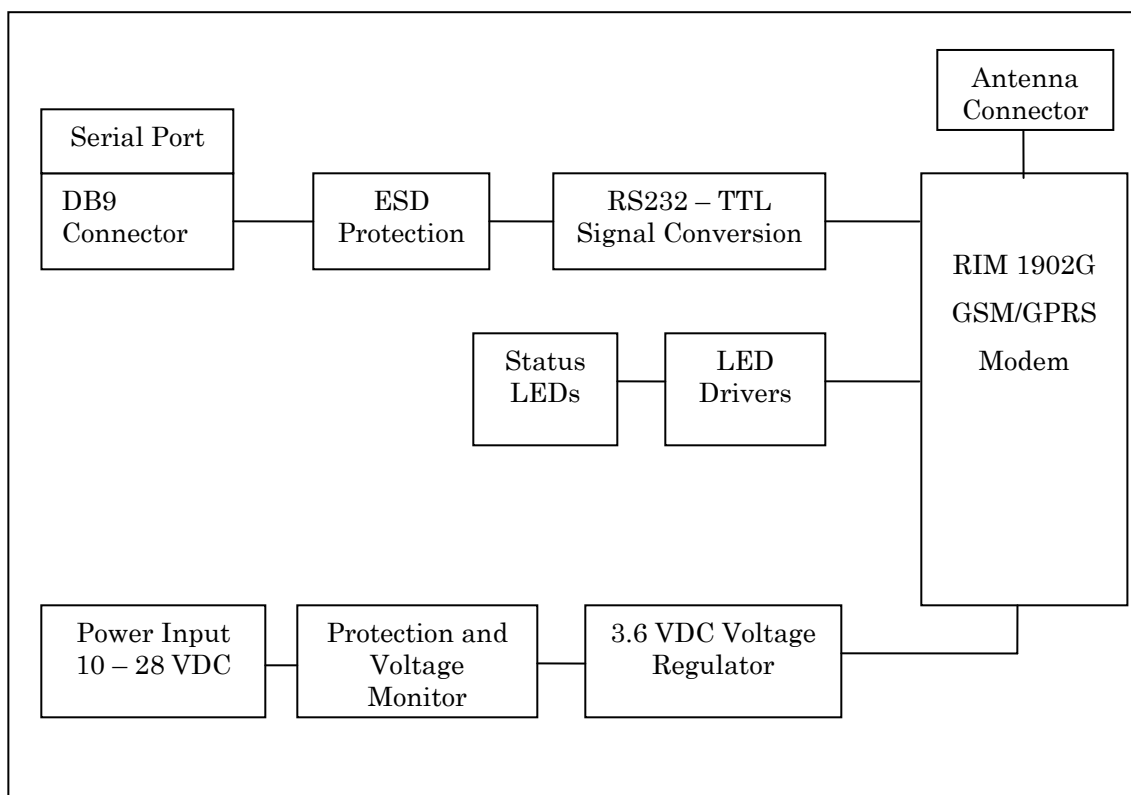

3 Description

3.1 RIM 1902G Modem

RIM's embedded OEM GSM/GPRS modem module, the 1902G, is used to provide the GSM/GPRS modem functions.

3.2 Power Input Protection

Power input over-current protection is provided by employing a 500 ma resettable PTC device that will open when the input current exceeds 500 ma. After a period of time, it will reset and conduct current again.

A diode in the power input ground path protects against accidental reverse power connections. Current is blocked from flowing through the ground path to other external ground connections to the modem.

Overvoltage protection is provided with a tranzorb connected across the power input lines. It will conduct the input voltage to ground if the input voltage exceeds 30V.

A voltage monitor circuit will turn the voltage regulator on and off at levels sufficient to insure proper operation of the modem. As the voltage drops, the monitor will turn off the regulator when the input voltage is not sufficient for the regulator. As the voltage rises, the monitor will not start the regulator until the voltage is sufficiently above the turn-off level to insure it doesn't dip below the low level when current is supplied to the modem.

3.3 Serial Port Protection and Conversion

The signal lines connected to the DB9 connector are each protected against ESD with a series resistor and a 12 VDC tranzorb that will absorb momentary high voltage discharges.

A RS232 transceiver translates the DB9 RS232 level signals to the TTL level signals required by the 1902G, and vice-versa.

3.4 LED Drivers

Buffer drivers supply the needed current to drive the status LEDs for the 1902G.

3.5 Antenna Connector

An industry standard TNC connector is provided for external antenna connections.