

G3110 G3210 G3310

Feature Comparison

Version 1.0

AirLink Communications, Inc.

October 14, 2003

Information in this document is subject to change without notice.
© Copyright AirLink Communications, Inc, 1993-2003. All rights reserved.

Please send comments to:

email: pubs@AirLink.com

Fax: 510-226-4299

Phone: 510-226-4200

Post: AirLink Communications, Inc.
Attention: Technical Publications Dept.
472 Kato Terrace
Fremont, CA 94539

Table of Contents

1	Introduction	1
2	Overview of Common Features.....	1
2.1	Redwing Block Diagram	2
2.2	Raven Block Diagram	3
2.3	PinPoint Block Diagram.....	4
2.4	RIM 1902G OEM Module	5
2.5	Voltage Regulators.....	5
2.6	Power Input Protection.....	5
2.7	Serial Port Protection and Conversion	5
3	Raven and PinPoint Enhancements	6
3.1	ALEOS Features	6
3.2	Real-Time Clock.....	6
3.3	Voltage Regulator Control.....	6
3.4	GPS Module in PinPoint.....	6
4	Network Operations	7
4.1	Redwing.....	7
4.2	Raven and PinPoint.....	8

G3110 G3210 G3310 Feature Comparison

1 Introduction

The Redwing [G3110], Raven [G3210], and PinPoint [G3310] GPRS modems are designed to operate in GPRS networks. The Redwing is intended to be used with intelligent devices that contain a TCP/IP protocol stack, and use the Redwing only as a GPRS network access device. The Raven and PinPoint modems add an ARM processor and a real-time clock which enhances the capabilities of these modems. The Raven can interface with a large number of different devices and provide the data communications functions necessary for the devices to operate over a GPRS network. The PinPoint contains the same functionality as the Raven, and adds a GPS module to provide location information.

2 Overview of Common Features

The GPRS modems share a number of common hardware features. The AirLink GPRS modems use the RIM OEM module, the 1902G, to implement the GSM/GPRS modem functions. AirLink mounts all the components for the modems in rugged enclosures which provide physical and electrical protection, and a wide range power regulator.

The following block diagrams show the major hardware functions for each.

2.1 Redwing Block Diagram

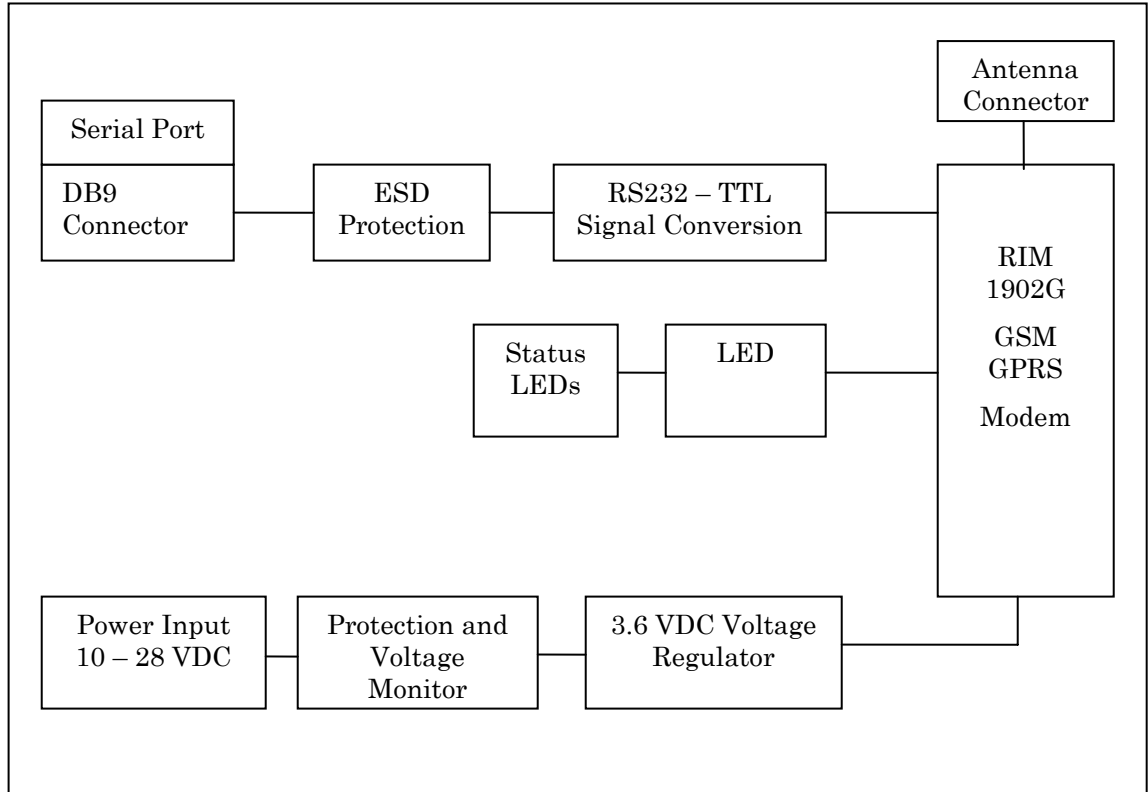

2.2 Raven Block Diagram

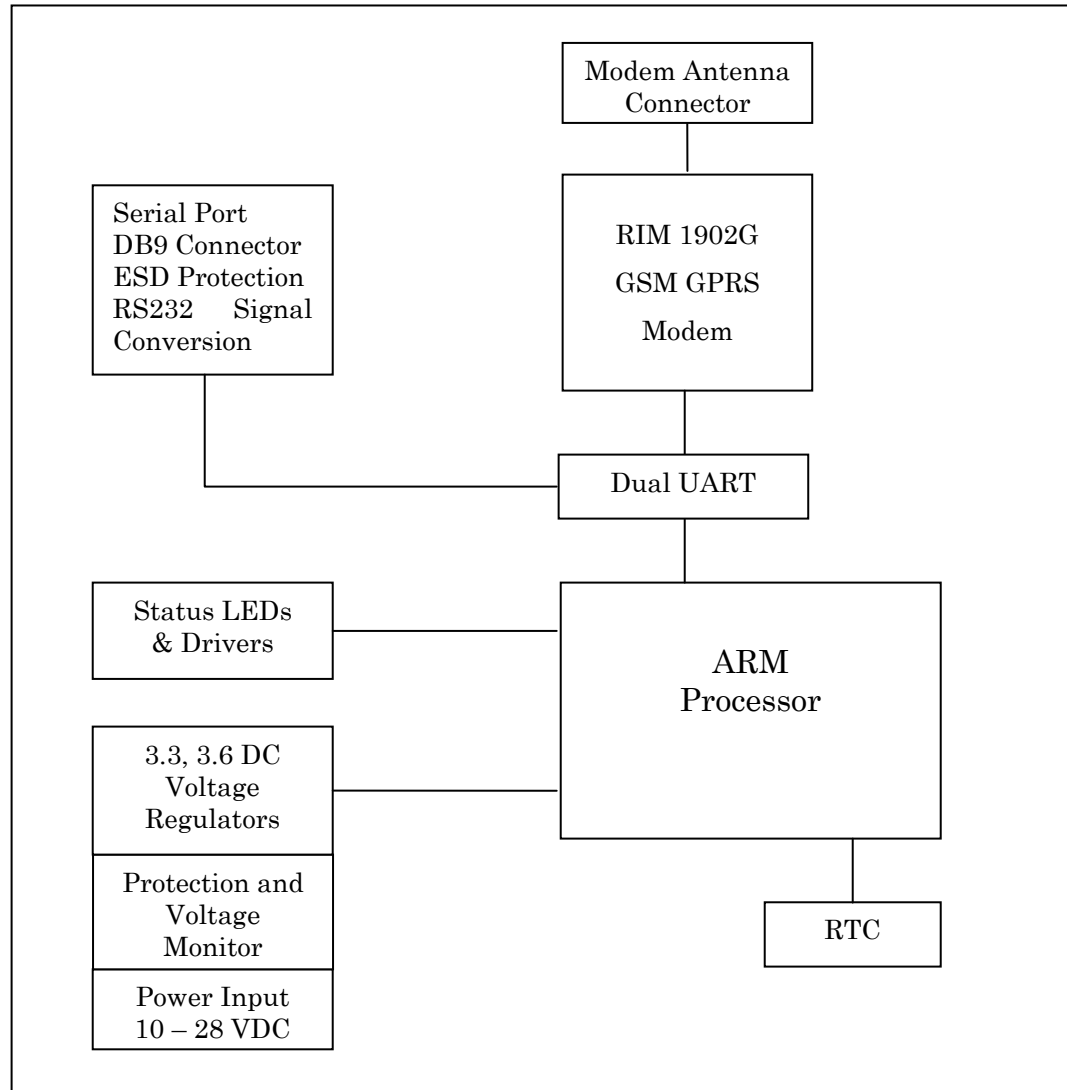

2.3 PinPoint Block Diagram

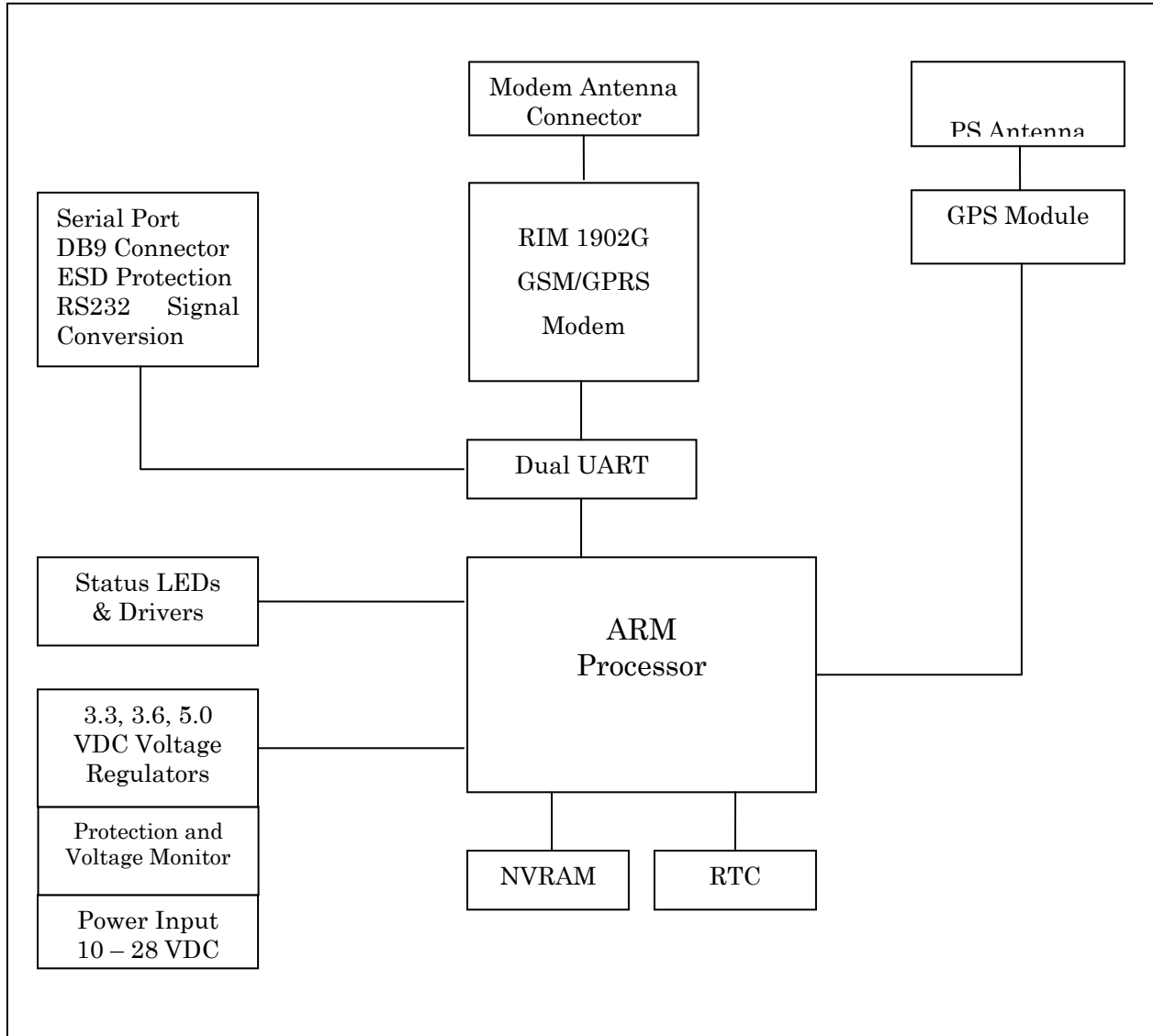

2.4 RIM 1902G OEM Module

RIM's embedded OEM GPRS modem module, the 1902G, is used to provide the GSM/GPRS modem functions in the AirLink GPRS modems.

2.5 Voltage Regulators

An efficient switching voltage regulator converts the 10 to 28 VDC input power to 3.6 VDC in the Redwing and 5.3 VDC in the Raven and PinPoint. A pair of linear voltage regulators regulates the 5.3 VDC to 3.3 and 3.6 VDC in the Raven and PinPoint.

2.6 Power Input Protection

Power input over-current protection is provided by employing a 500 ma resettable PTC device that will open when the input current exceeds 500 ma. After a period of time, it will reset and conduct current again.

A diode in the power input ground path protects against accidental reverse power connections. Current is blocked from flowing through the ground path to other external ground connections to the modem.

Overvoltage protection is provided with a tranzorb connected across the power input lines. It will conduct the input voltage to ground if the input voltage exceeds 30V.

A voltage monitor circuit will turn the voltage regulator on and off at levels sufficient to insure proper operation of the modem. As the voltage drops, the monitor will turn off the regulator when the input voltage is not sufficient for the regulator. As the voltage rises, the monitor will not start the regulator until the voltage is sufficiently above the turn-off level to insure it doesn't dip below the low level when current is supplied to the modem.

2.7 Serial Port Protection and Conversion

The signal lines connected to the DB9 connector are each protected against ESD with a series resistor and a 12 VDC tranzorb that will absorb momentary high voltage discharges.

A RS232 transceiver translates the DB9 RS232 level signals to the TTL level signals required by the 1902G, and vice-versa.

3 Raven and PinPoint Enhancements

From the hardware vantage point, the Raven is different from the Redwing only by the addition of an ARM processor and its support chips. The PinPoint further adds a GPS module to the functionality of the Raven. The ARM processor adds a significant software capability that gives the Raven and PinPoint a large boost in functionality. AirLink has developed the AirLink Embedded Operating System [ALEOS] to provide the many features used to interface to a multitude of devices in many different environments.

3.1 ALEOS Features

- Embedded TCP/IP stack
- Dynamic IP solutions
- Security, encryption, IP screening, password access
- Device protocol spoofing
- Device protocol conversions
- Power management
- Remote configuration and monitoring
- Over the air firmware update
- Over the air application debugging
- PinPoint can transmit location information at configurable times and distances

3.2 Real-Time Clock

A Real-Time Clock [RTC] allows the ARM processor to provide wake up functions to perform tasks on a scheduled basis. Examples are waking up from a low power mode periodically to send data, sending periodic messages to verify proper operation, scanning a local device on a schedule, sending a data logs on a periodic basis.

3.3 Voltage Regulator Control

The ARM processor can power down the OEM module [and GPS module in the PinPoint] to enter a low power mode or to power cycle the 1902G.

3.4 GPS Module in PinPoint

A GPS module provides location information, latitude and longitude, and very accurate time. This information is used to track vehicles, provide the location of the device, and provide timestamps to events.

4 Network Operations

There is a difference in the way the modems perform the GPRS network connections.

4.1 Redwing

When the user or device establishes a PPP link to the Redwing, there are two PPP links established. One is between the user host computer or device to the 1902G module, and the second is between the 1902G and the GPRS network. They both exist simultaneously. If either PPP link is disconnected, the other is subsequently disconnected.

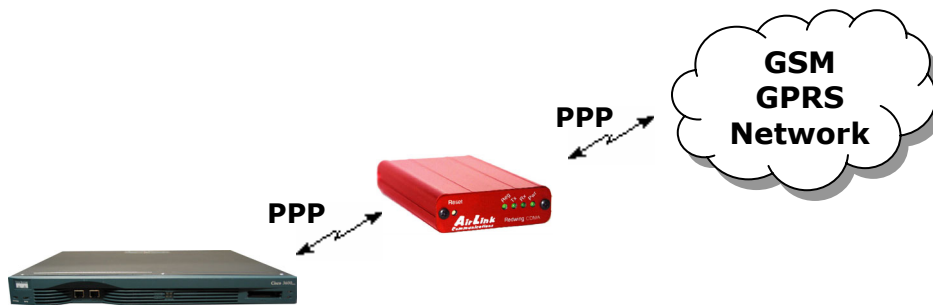

4.2 Raven and PinPoint

When the Raven or PinPoint is powered on, ALEOS establishes a PPP link to the 1902G, which, in turn, establishes the PPP link to the GPRS network. The host can either establish a PPP link to ALEOS or use the data services in ALEOS to transfer data to and from the network.

When data is sent to the modem from the host device, ALEOS first verifies that the network connection is dormant or not. If the link is dormant, ALEOS will activate the link and verify that the network PPP link is still established. If the link is not still active, it will be re-established and the host device data forwarded to the network.

