

TEST REPORT

Report Number: 104368457MPK-002
Project Numbers: G103948971, G104368457
November 3, 2020

Testing performed on the
SmartValve™ with Integrated Bypass
Model Number: SmartValve 10-3600i-63

FCC ID: QPS01009
IC: 22326-01009

To
FCC Part 15 Subpart C (15.247)
ISED RSS-247 Issue 2

For
Smart Wires, Inc.

Test Performed by:
Intertek
1365 Adams Court
Menlo Park, CA 94025 USA

Test Authorized by:
Smart Wires, Inc.
3292 Whipple Rd.
Union City, CA 94587 USA

Prepared by: 
Anderson Soungpanya

Date: November 3, 2020

Reviewed by: 
Krishna K Vemuri

Date: November 3, 2020

This report is for the exclusive use of Intertek's Client and is provided pursuant to the agreement between Intertek and its Client. Intertek's responsibility and liability are limited to the terms and conditions of the agreement. Intertek assumes no liability to any party, other than to the Client in accordance with the agreement, for any loss, expense or damage occasioned by the use of this report. Only the Client is authorized to copy or distribute this report and then only in its entirety. Any use of the Intertek name or one of its marks for the sale or advertisement of the tested material, product or service must first be approved in writing by Intertek. The observations and test results in this report are relevant only to the sample tested. This report by itself does not imply that the material, product, or service is or has ever been under an Intertek certification program. This report must not be used to claim product endorsement by A2LA, NIST nor any other agency of the U.S. Government.

Report No. 104368457MPK-002	
Equipment Under Test:	SmartValve™ with Integrated Bypass
Trade Name:	Smart Wires, Inc.
Model Number(s):	SmartValve 10-3600i-63
Applicant:	Smart Wires, Inc.
Contact:	Karamjit Singh
Address:	Smart Wires, Inc. 3292 Whipple Rd. Union City, CA 94587
Country:	USA
Tel. Number:	(510) 952-2668
Email:	karamjit.singh@smartwires.com
Applicable Regulation:	FCC Part 15 Subpart C (15.247) ISED RSS-247 Issue 2
Date of Test:	November 22 – December 10, 2019 & September 11 to October 14, 2020

We attest to the accuracy of this report:



Anderson Soungpanya
Project Engineer



Krishna K Vemuri
EMC Manager

TABLE OF CONTENTS

1.0	Introduction	4
1.1	Summary of Tests	4
2.0	General Description	5
2.1	Product Description	5
2.2	Related Submittal(s) Grants.....	6
2.3	Test Methodology.....	6
2.4	Test Facility	6
3.0	System Test Configuration	7
3.1	Support Equipment.....	7
3.2	Block Diagram of Test Setup.....	7
3.3	Justification	8
3.4	Mode of Operation During Test.....	8
3.5	Modifications Required for Compliance	8
3.6	Additions, Deviations and Exclusions from Standards.....	8
4.0	Emissions Measurement Results	9
4.1	20dB Bandwidth, and 99% Occupied Bandwidth	9
4.2	Conducted Output Power at Antenna Terminals	14
4.3	Carrier Frequency Separation	19
4.4	Number of Channels	21
4.5	Average Channel Occupancy Time	23
4.6	Out-of-Band Conducted Emissions	26
4.7	Transmitter Radiated Emissions	34
4.8	AC Line Conducted Emission.....	63
5.0	List of Test Equipment and Software.....	68
6.0	Document History	70

1.0 Introduction

This report is designed to show compliance of the EUT's 2.4GHz transceiver with the requirements of FCC Part 15 Subpart C (15.247) and RSS-247. This test report covers only the FHSS radio.

1.1 Summary of Tests

TEST	Reference FCC	Reference ISED	RESULTS
RF Output Power	15.247(b)	RSS-247, 5.4.2	Complies
20-dB Bandwidth	15.247(a)(1)	RSS-247, 5.1.1	Complies
Channel Separation	15.247(a)(1)	RSS-247, 5.1.2	Complies
Number of Hopping Channels	15.247(a)(1)	RSS-247, 5.14	Complies
Average Channel Occupancy Time	15.247(a)(1)	RSS-247, 5.14	Complies
Out-of-Band Antenna Conducted Emission	15.247(d)	RSS-247, 5.5	Complies
Transmitter Radiated Emissions	15.247(d), 15.209, 15.205	RSS-GEN	Complies
RF Exposure	15.247(i)	RSS-102	Complies
AC Conducted Emission	15.207	RSS-GEN	Complies
Antenna Requirement	15.203	RSS-GEN	Complies (Professional Installation)

2.0 General Description

2.1 Product Description

Smart Wires, Inc. supplied the following description of the EUT:

The SmartValve™ with Integrated Bypass builds upon the success of its predecessors. By using revolutionary power electronics, the SmartValve effectively increases or decreases the reactance of a given circuit, enabling real-time control of power flow. A modular, Static Synchronous Series Compensator (SSSC), the SmartValve injects a leading or lagging voltage in quadrature with the line current, providing the functionality of a series capacitor or series reactor respectively. However, unlike conventional series capacitors or reactors, the SmartValve can inject the voltage independently of the line current, thus increasing the ohmic injection when operated below the rated value. Also, the SmartValve does not have the negative characteristics of these passive devices, such as the risk of sub-synchronous resonance (SSR) with series capacitors and the constant VAr consumption of series reactors. As a modular device that can be deployed and re-deployed, the solution size of an installation can be scaled up or down to support the dynamic needs of the transmission grid. Given the fast response of the unit’s power electronics, the unit can provide dynamic services and its set-point can be changed frequently to actively manage power flows with no degradation in unit life.

For more information, see user’s manual provided by the manufacturer.

Information about the 2.4 GHz radio is presented below:

Applicant	Smart Wires, Inc.
Model No.	SmartValve 10-3600i-63
FCC Identifier	QPS01009
IC Identifier	22326-01009
Type of Transmission	Frequency Hopping Spread Spectrum
Rated RF Output	16.40 dBm
Antenna(s) & Gain	Internal Antenna, Gain: 5.0 dBi
Frequency Range	2436.000000 – 2463.921747 MHz
Number of Channel(s)	24
Modulation Type	2-FSK
Applicant Name & Address	Smart Wires, Inc. 3292 Whipple Rd. Union City, CA 94587 USA

EUT receive date: November 18, 2019, September 10, 2020

EUT receive condition: The pre-production version of the EUT was received in good condition with no apparent damage. As declared by the Applicant, it is identical to the production units.

Test start date: November 22, 2019, September 11, 2020

Test completion date: December 10, 2019, October 14, 2020

The test results in this report pertain only to the item tested.

2.2 Related Submittal(s) Grants

None.

2.3 Test Methodology

Antenna conducted measurements were performed according to the FCC documents "Guidance for Performing Compliance Measurement on Digital Transmission Systems, Frequency Hopping Spread Spectrum System, and Hybrid System devices Operating under §15.247" (KDB 558074 D01 15.247 Meas Guidance v05r02), RSS-247 Issue 2, ANSI C63.10: 2013 and RSS-GEN Issue 5.

Radiated emissions and AC mains conducted emissions measurements were performed according to the procedures in ANSI C63.10: 2013 & ANSI C63.4-2014. Radiated tests were performed at an antenna to EUT distance of 3 meters, unless stated otherwise in the "Data Sheet" of this report.

All other measurements were made in accordance with the procedures in part 2 of CFR 47.

Following is the channel test plan:

Channels in 2.4 GHz band			
Test Channel		Frequency, MHz	Tested
Low	0	2436.000000	√
Middle	12	2450.567868	√
High	23	2463.921747	√
Hopping Mode	0-23	2436.000000 - 2463.921747	√

2.4 Test Facility

The test site used to collect antenna port testing is located at 1365 Adams Court, Menlo Park, California, 94025. This test facility and site measurement data have been fully placed on file with the FCC, IC and A2LA accredited.

The test site for radiated emission measurements was tested in-situ: Smart Wires, Inc. 3292 Whipple Rd Union City, CA 9458

3.0 System Test Configuration

3.1 Support Equipment

Description	Manufacturer	Model Number
Laptop	DELL	Latitude 7490
DC Power Supply	Exetech	D30030012

3.2 Block Diagram of Test Setup

Equipment Under Test			
Description	Manufacturer	Model Number	Serial Number
Communication Device	Smart Wires, Inc.	SmartValve 10-3600i-63	11520-001-10-04-63-04

Antenna was removed and co-axial connector with a cable was installed for Conducted Measurements.

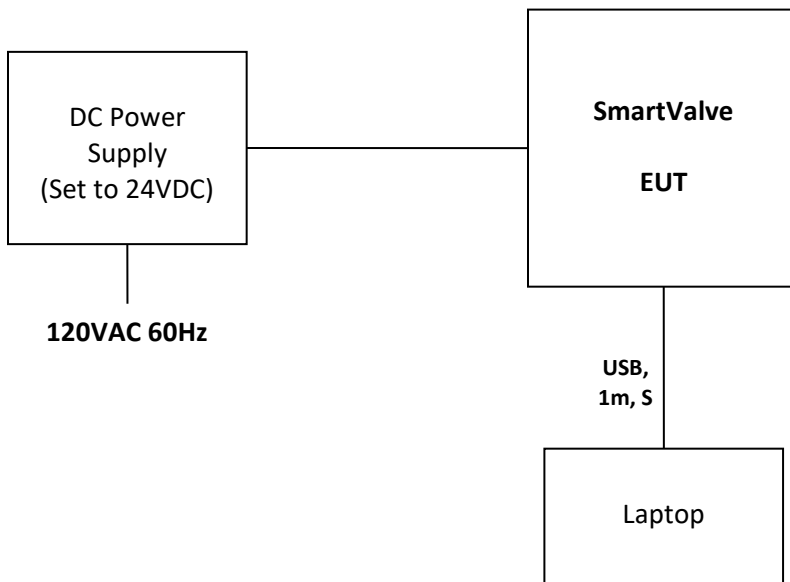

S = Shielded	F = With Ferrite
U = Unshielded	m = Length in Meters

3.3 Justification

The SmartValve' size and weight were excessive (>16,000 pounds) to safely lift onto an 80cm or 1.5m table for testing or to move into a semi-anechoic chamber. Due to the practical considerations dictated by the size and installation, requirements of the Equipment Under Test (EUT), testing was performed *in situ* at the applicant's location. Arrangements were made to perform *in situ* testing at the client's premise with the approval from FCC.

For radiated emission measurements the EUT is attached to peripherals and they are connected and operational (as typical as possible). The EUT is wired to transmit full power. During testing, all cables are manipulated to produce worst-case emissions.

Per the manufacturer, the SmartBypass 2000-63 and SmartValve 10-3600i-63 uses the identical RF circuitry and PCB boards. Hence, conducted antenna port measurements are taken from report number 103948971MPK-002.

3.4 Mode of Operation During Test

During transmitter testing, the transmitter was setup to transmit continuously at maximum RF power on the low channel, middle channel, high channel and with hopping channels enabled.

The Maximum power allowed by the manufacturer's provided GUI is RF Power = 15

Radiated Spurious testing on 2.4GHz Radio was performed with simultaneous transmission of 900MHz Radio.

3.5 Modifications Required for Compliance

Intertek installed no modifications during compliance testing in order to bring the product into compliance.

3.6 Additions, Deviations and Exclusions from Standards

No additions, deviations or exclusions from the standard were made.

4.0 Emissions Measurement Results

**4.1 20dB Bandwidth, and 99% Occupied Bandwidth
FCC Rule 15.247(a)(1)**

4.1.1 Procedure

The Procedure described in the FCC Publication 558074 D01 Meas Guidance v05r02 & Section 7.8.7 of ANSI C63.10:2013 for Frequency Hopping Spread Spectrum Systems was used to determine the 20dB bandwidth.

- Span = Approximately 2 to 3 times the 20 dB bandwidth, centered on a hopping channel
- RBW = 1% of the 20 dB bandwidth
- VBW = 3 x RBW
- Sweep = Auto
- Detector function = Peak
- Trace = Max hold

The EUT should be transmitting at its maximum data rate. Allow the trace to stabilize. Use the marker-to-peak function to set the marker to the peak of the emission. Use the marker delta function to measure 20 dB down one side of the emission. Reset the marker-delta function, and move the marker to the other side of the emission, until it is (as close as possible to) even with the reference marker level. The marker-delta reading at this point is the 20 dB bandwidth of the emission. If this value varies with different modes of operation (e.g., data rate, modulation format, etc.), repeat this test for each variation. The limit is specified in one of the subparagraphs of this Section. Submit this plot(s).

For 99% power bandwidth measurement, the bandwidth was determined by using the built-in 99% occupied bandwidth function of the spectrum analyzer.

The antenna port of the EUT was connected to the input of a spectrum analyzer (SA). For each RF output channel investigated, the spectrum analyzer center frequency was set to the channel carrier. A Peak output reading was taken, a Display line was drawn for 20dB lower than Peak level. The 20dB bandwidth was determined from where the channel output spectrum intersected the display line.

Tested By	Test Date
Anderson Soungpanya	November 27, 2019

4.1.2 Test Result

Frequency MHz	20 dB FCC Bandwidth, kHz	99% Bandwidth, kHz	Plot #
2436.000000	793.269	764.423	1.1
2450.567868	846.154	764.423	1.2
2463.921747	822.115	802.885	1.3

Results	Complies
----------------	----------

Plot 1. 1 – 20dB Bandwidth and 99% Bandwidth Low Channel

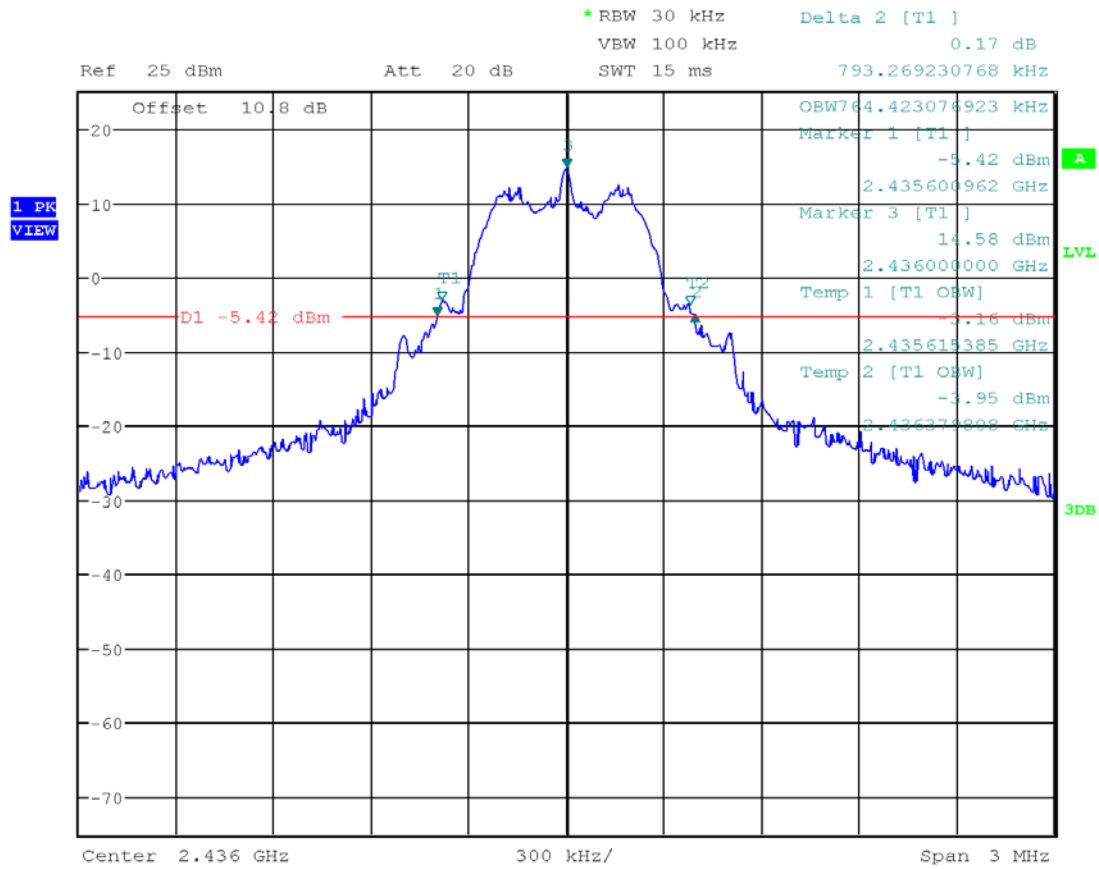

Date: 27.NOV.2019 08:53:12

Plot 1. 2 – 20dB Bandwidth and 99% Bandwidth Middle Channel

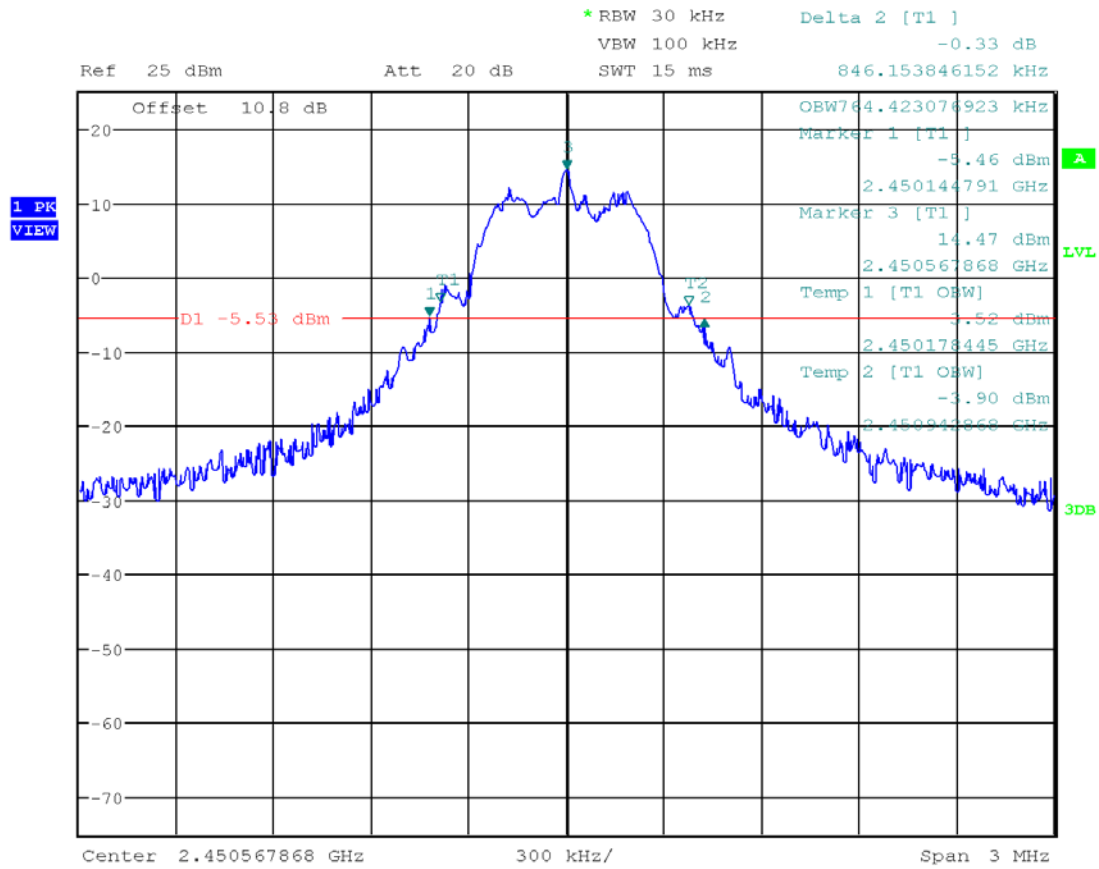

Date: 27.NOV.2019 08:40:30

Plot 1. 3 – 20dB Bandwidth and 99% Bandwidth High Channel

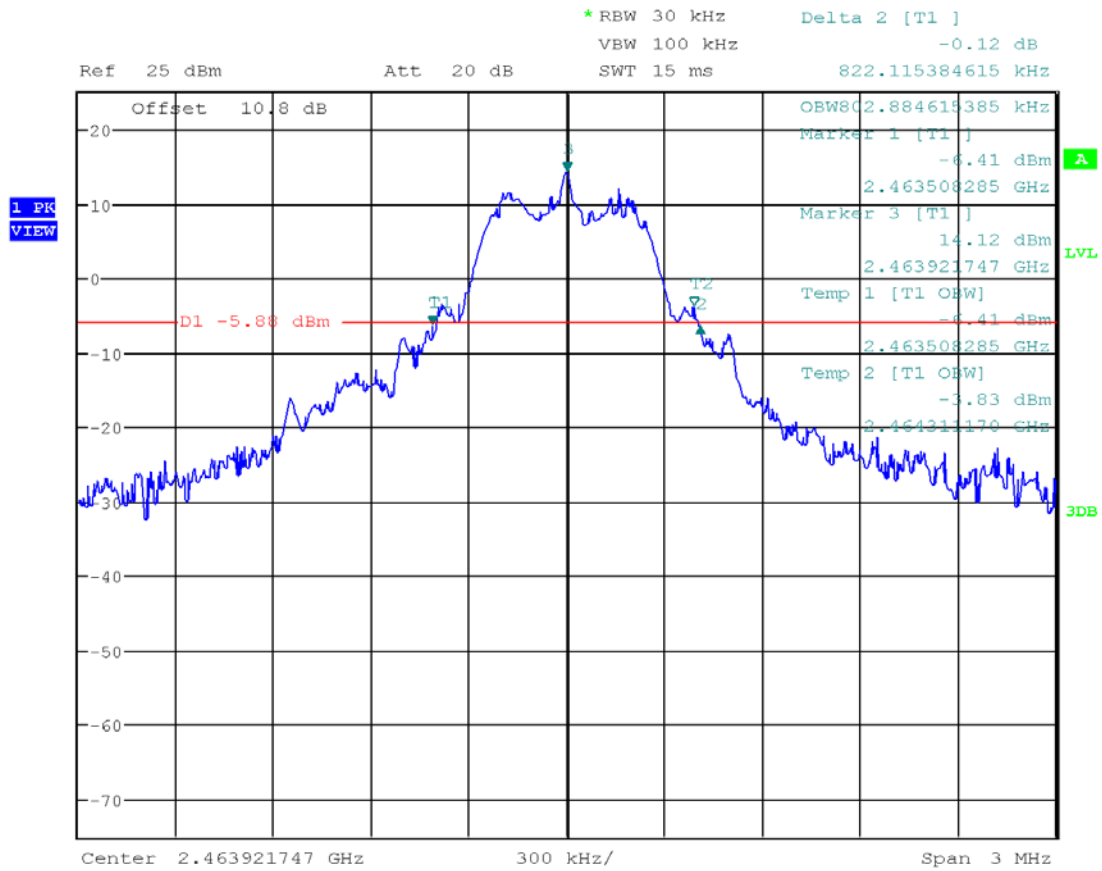

Date: 27.NOV.2019 08:35:25

4.2 Conducted Output Power at Antenna Terminals
FCC Rule 15.247(b)(1)

4.2.1 Requirement

For frequency hopping systems operating in the 2400-2483.5 MHz band employing at least 75 non-overlapping hopping channels, and all frequency hopping systems in the 5725-5850 MHz band: 1 watt. For all other frequency hopping systems in the 2400-2483.5 MHz band: 0.125 watts.

4.2.2 Procedure

The procedure described in FCC Publication 558074 D01 Meas Guidance v05r02 was used. Specifically, Section 7.8.5 of ANSI C63.10:2013 for Frequency Hopping Spread Spectrum Systems was used to determine the RF Output Power.

- Span = approximately 5 times the 20 dB bandwidth, centered on a hopping channel
- RBW > the 20 dB bandwidth of the emission being measured
- VBW = 3 x RBW
- Sweep = auto
- Detector function = peak
- Trace = max hold

Allow the trace to stabilize. Use the marker-to-peak function to set the marker to the peak of the emission. The indicated level is the peak output power (see the NOTE above regarding external attenuation and cable loss). The limit is specified in one of the subparagraphs of this Section. Submit this plot.

The antenna port of the EUT was connected to the input of a spectrum analyzer. Power was read directly from the spectrum analyzer and cable loss correction was added to the reading to obtain the power at the antenna terminals.

Tested By	Test Date
Anderson Soungpanya	November 27, 2019

4.2.3 Test Result

Refer to the following plots for the test result:

Frequency MHz	Conducted Peak Power dBm	Conducted Peak Power mW	Plot #
2436.000000	16.40	43.652	2.1
2450.567868	16.17	41.400	2.2
2463.921747	15.93	39.174	2.3

Results	64 Channels used; Complies
----------------	----------------------------

Plot 2. 2 – Output Power Low Channel

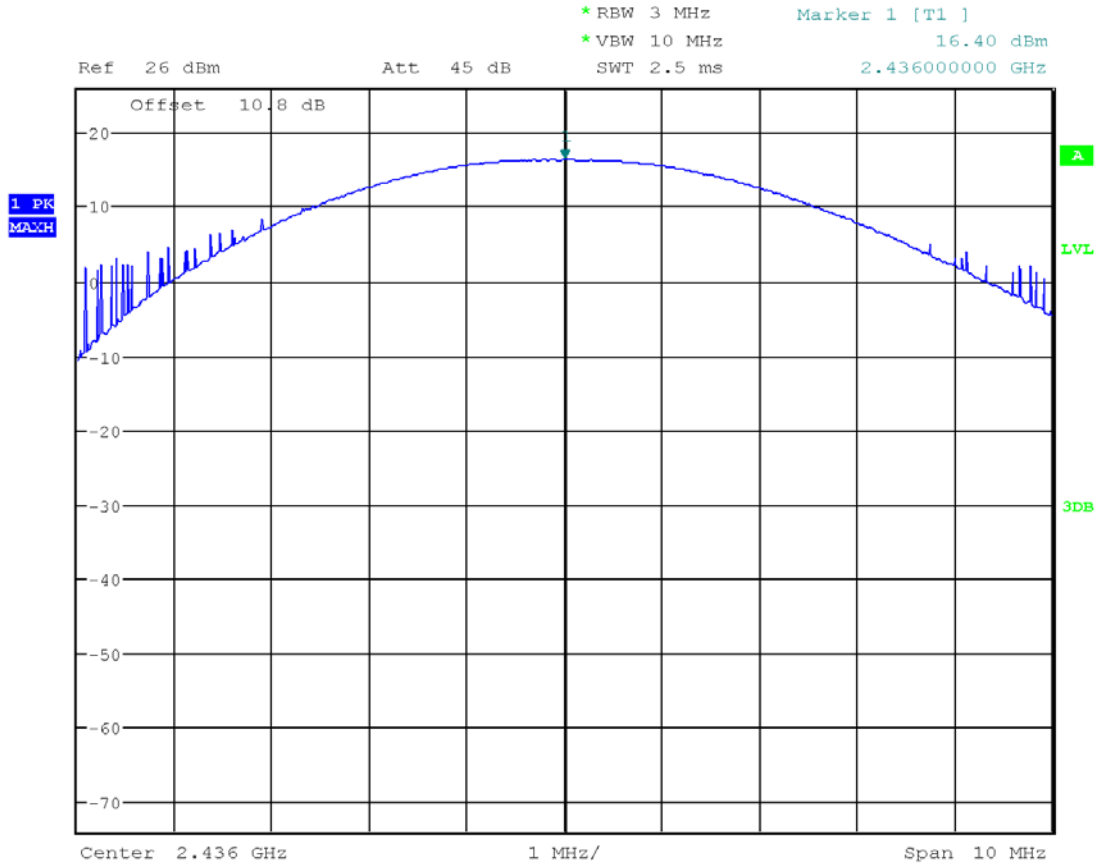

Date: 27.NOV.2019 08:23:26

Plot 2.2 – Output Power Middle Channel

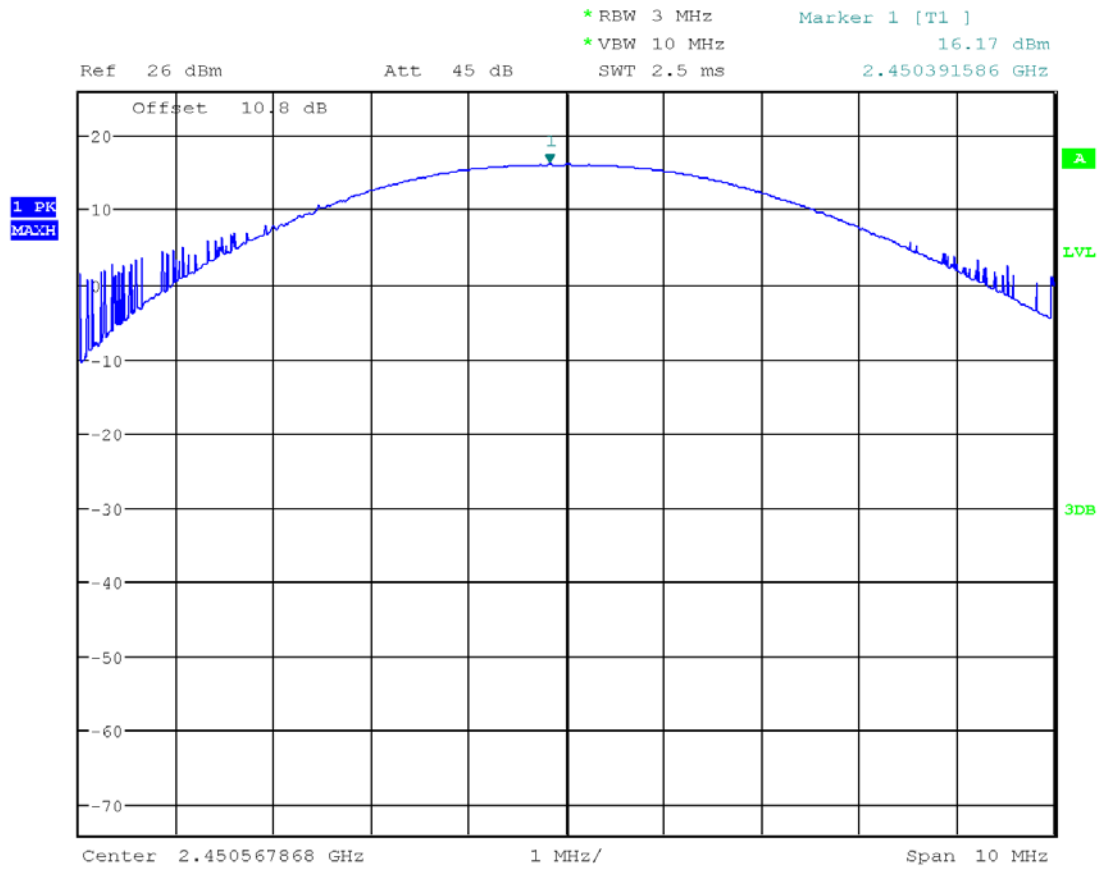

Date: 27.NOV.2019 08:24:37

Plot 2. 3 – Output Power High Channel

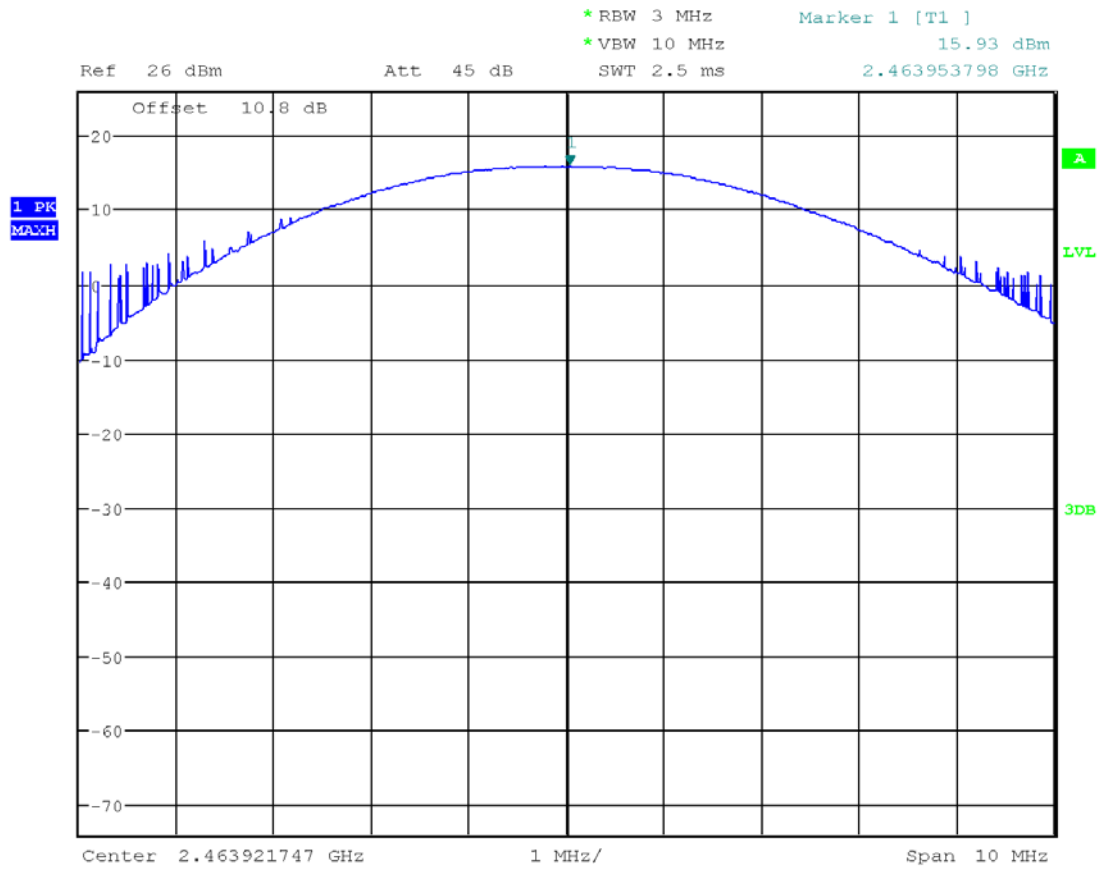

Date: 27.NOV.2019 08:25:35

4.3 Carrier Frequency Separation
FCC 15.247 (a)(1)

4.3.1 Requirement

Frequency hopping systems shall have hopping channel carrier frequencies separated by a minimum of 25 kHz or the 20 dB bandwidth of the hopping channel, whichever is greater. Alternatively, frequency hopping systems operating in the 2400-2483.5 MHz band may have hopping channel carrier frequencies that are separated by 25 kHz or two-thirds of the 20 dB bandwidth of the hopping channel, whichever is greater.

4.3.2 Procedure

The procedure described in FCC Publication 558074 D01 Meas Guidance v05r02 was used. Specifically, Section 7.8.2 of ANSI C63.10:2013 for Frequency Hopping Spread Spectrum Systems was used to determine the Carrier Frequency Separation.

- The EUT must have its hopping function enabled
- Span = wide enough to capture the peaks of two adjacent channels
- Resolution (or IF) Bandwidth (RBW) = 1% of the span
- Video (or Average) Bandwidth (VBW) = 3 x RBW
- Sweep = auto
- Detector function = peak
- Trace = max hold

Allow the trace to stabilize. Use the marker-delta function to determine the separation between the peaks of the adjacent channels.

Tested By	Test Date
Anderson Soungpanya	November 27, 2019

4.3.3 Test Result

The worst case 20dB Bandwidth is 845.154 kHz, therefore the minimum Carrier Frequency Separation shall be greater than two thirds of 845.154 kHz (563.718 kHz). The measured channel separation is 1.218 MHz. Carrier Frequency Separation meets the minimum requirement. Please refer to spectrum analyzer Plot 3.1 below for the test result.

Plot 3.1– Channel Separation

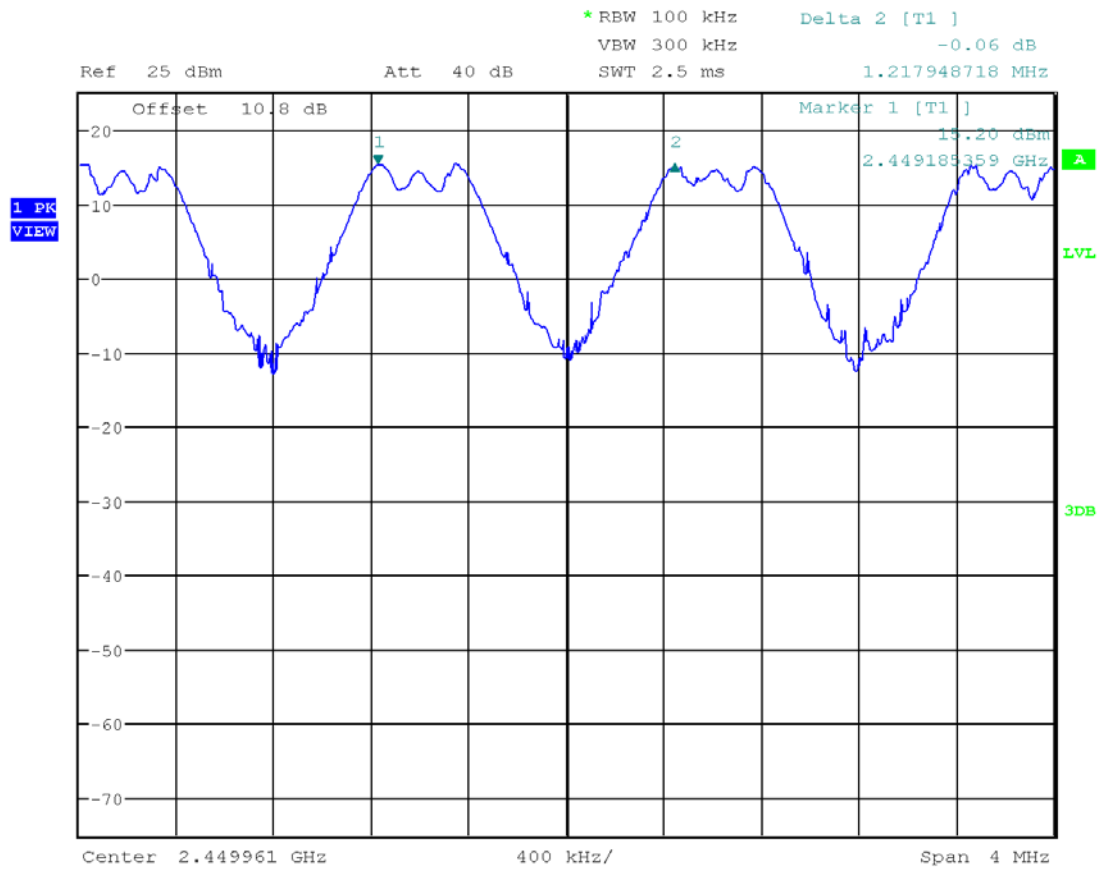

Date: 27.NOV.2019 09:33:25

Results **Complies**

4.4 Number of Channels
FCC 15.247 (a)(1)(iii)

4.4.1 Requirement

For frequency hopping systems operating in the 902-928 MHz band: if the 20 dB bandwidth of the hopping channel is less than 250 kHz, the system shall use at least 50 hopping frequencies and the average time of occupancy on any frequency shall not be greater than 0.4 seconds within a 20 second period; if the 20 dB bandwidth of the hopping channel is 250 kHz or greater, the system shall use at least 25 hopping frequencies and the average time of occupancy on any frequency shall not be greater than 0.4 seconds within a 10 second period. The maximum allowed 20 dB bandwidth of the hopping channel is 500 kHz.

Frequency hopping systems in the 2400-2483.5 MHz band shall use at least 15 channels. The average time of occupancy on any channel shall not be greater than 0.4 seconds within a period of 0.4 seconds multiplied by the number of hopping channels employed. Frequency hopping systems may avoid or suppress transmissions on a particular hopping frequency provided that a minimum of 15 channels are used.

4.4.2 Procedure

The procedure described in FCC Publication 558074 D01 Meas Guidance v05r02 was used. Specifically, Section 7.8.3 of ANSI C63.10:2013 for Frequency Hopping Spread Spectrum Systems was used to determine the Number of Channels.

- The EUT must have its hopping function enabled.
- Span = the frequency band of operation
- RBW = 1% of the span
- VBW = 3 x RBW
- Sweep = auto
- Detector function = peak
- Trace = max hold

Allow the trace to stabilize. It may prove necessary to break the span up to sections, in order to clearly show all of the hopping frequencies.

With the analyzer set to MAX HOLD, readings were taken once channels were filled in. The channel peaks were recorded and compared to the minimum number of channels required in the regulation.

Tested By	Test Date
Anderson Soungpanya	November 27, 2019

4.4.3 Test Result

Plot 4.1 - Number of hopping channels, 2435 – 2449 MHz

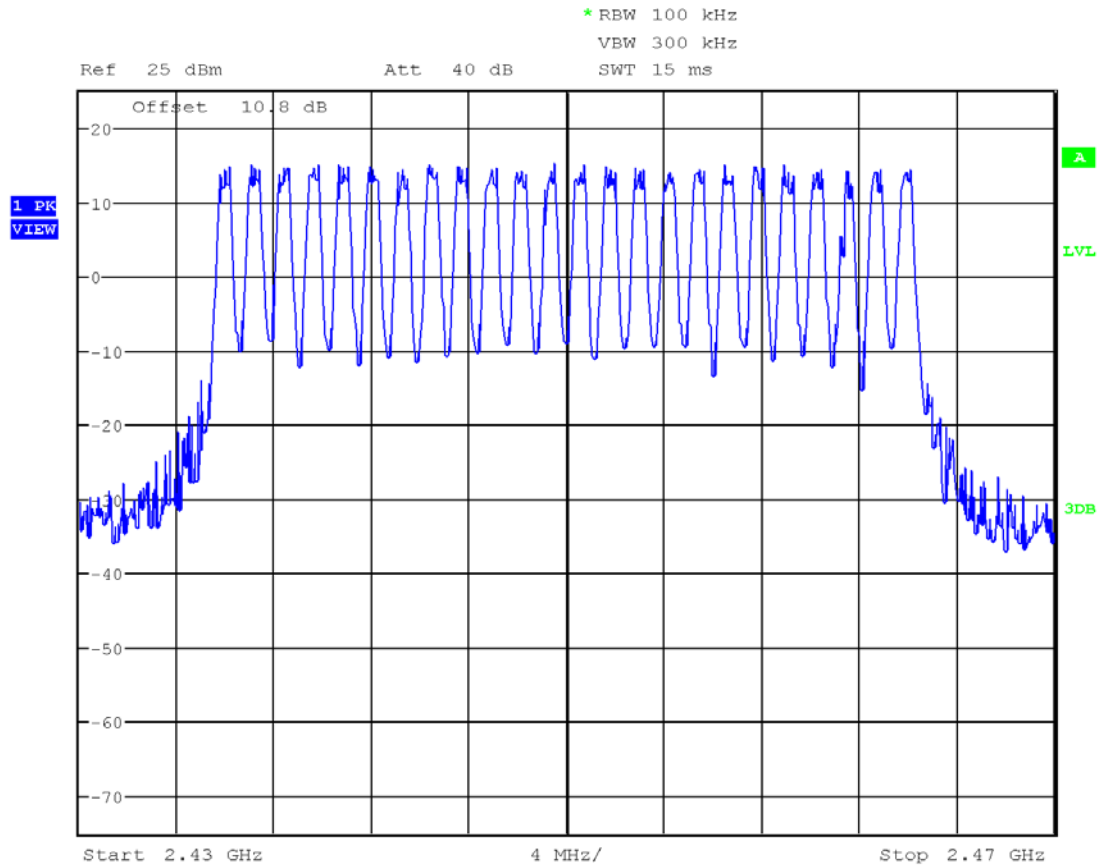

Date: 27.NOV.2019 09:21:28

Results Complies, 24 Channels

4.5 Average Channel Occupancy Time
FCC 15.247(a)(1)

4.5.1 Requirement

For frequency hopping systems operating in the 902-928 MHz band: if the 20 dB bandwidth of the hopping channel is less than 250 kHz, the system shall use at least 50 hopping frequencies and the average time of occupancy on any frequency shall not be greater than 0.4 seconds within a 20 second period; if the 20 dB bandwidth of the hopping channel is 250 kHz or greater, the system shall use at least 25 hopping frequencies and the average time of occupancy on any frequency shall not be greater than 0.4 seconds within a 10 second period. The maximum allowed 20 dB bandwidth of the hopping channel is 500 kHz.

Frequency hopping systems in the 2400-2483.5 MHz band shall use at least 15 channels. The average time of occupancy on any channel shall not be greater than 0.4 seconds within a period of 0.4 seconds multiplied by the number of hopping channels employed. Frequency hopping systems may avoid or suppress transmissions on a particular hopping frequency provided that a minimum of 15 channels are used.

4.5.2 Procedure

The procedure described in FCC Publication 558074 D01 Meas Guidance v05r02 was used. Specifically, Section 7.8.4 of ANSI C63.10:2013 for Frequency Hopping Spread Spectrum Systems was used to determine the Average Channel Occupancy Time.

- The EUT must have its hopping function enabled.
- Span = zero span, centered on a hopping channel
- RBW = 1 MHz
- VBW = 3 x RBW
- Sweep = as necessary to capture the entire dwell time per hopping channel
- Detector function = peak
- Trace = max hold

If possible, use the marker-delta function to determine the dwell time. If this value varies with different modes of operation (e.g., data rate, modulation format, etc.), repeat this test for each variation. The limit is specified in one of the subparagraphs of this Section. An oscilloscope may be used instead of a spectrum analyzer.

The spectrum analyzer center frequency was set to one of the known hopping channels, the SPAN was set to ZERO SPANS, and the TRIGGER was set to VIDEO. The time duration of the transmission so captured was measured with the MARKER DELTA function.

Tested By	Test Date
Anderson Soungpanya	November 27, 2019

4.5.3 Test Results

No. of Burst in 960 ms	Burst On Time (ms)	Dwell Time (ms) (Burst Time * No. of Burst * 10)	Dwell Time limit (ms)
7	0.442	30.94	400

The 20-dB bandwidth of the hopping channel is greater than 250 kHz, the average time of occupancy on any frequency shall not be greater than 0.4 seconds within a period of the number of channels (24) multiplied by 0.4 second (9.6 seconds).

Burst Time

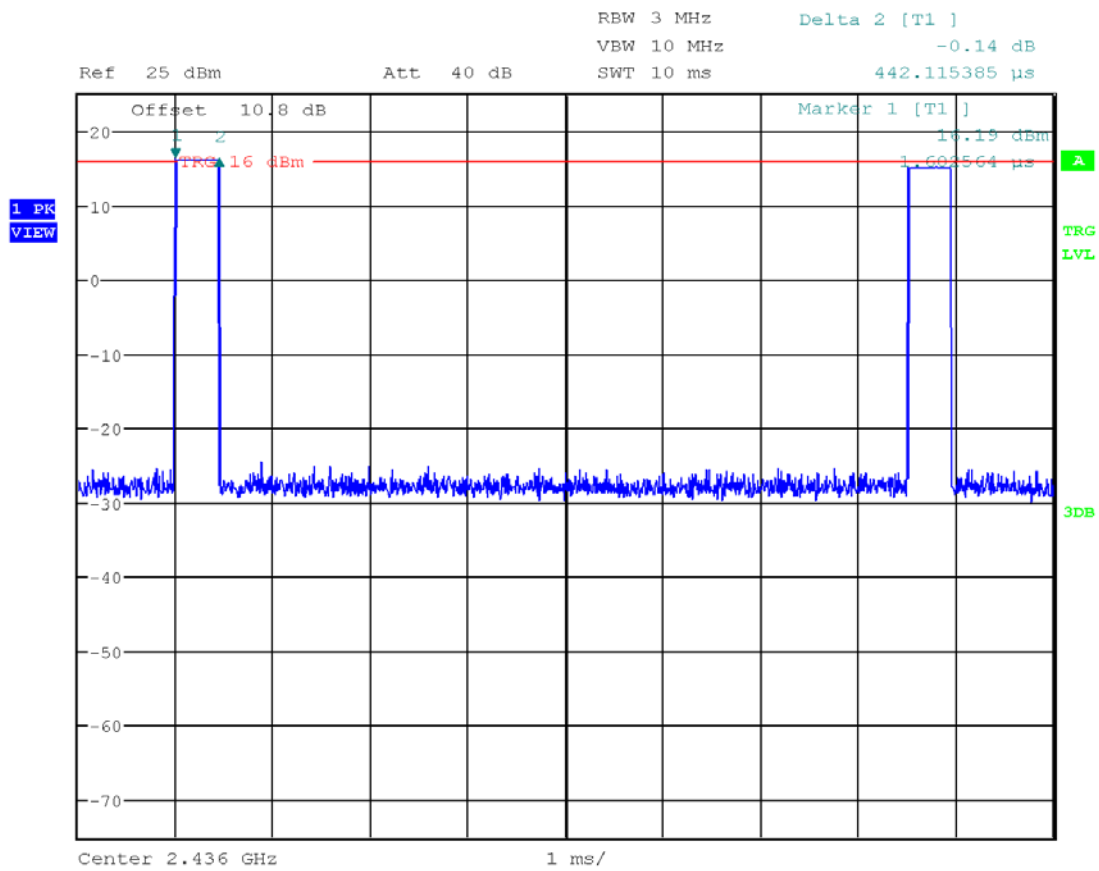

Date: 27.NOV.2019 09:37:24

4.5.3 Test Results (Continued)

Number of Burst in 960 ms

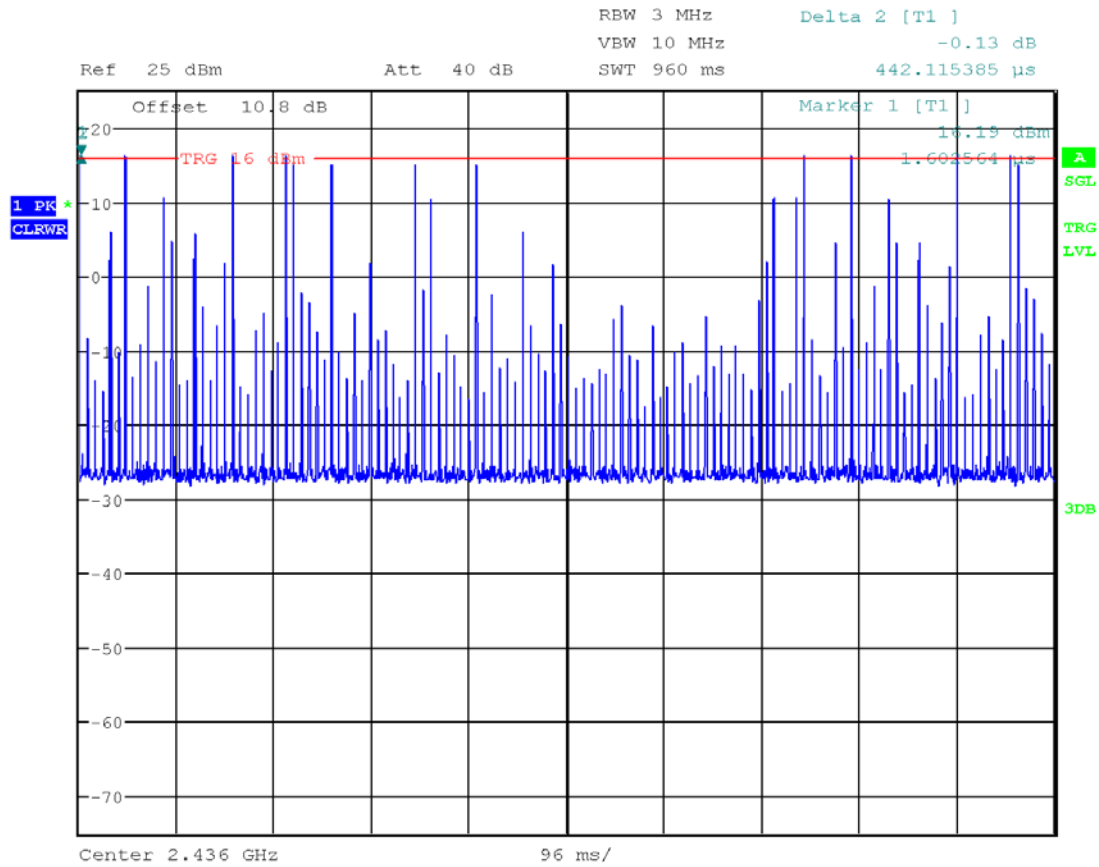

Date: 27.NOV.2019 09:40:48

Results **Complies**

4.6 Out-of-Band Conducted Emissions
FCC 15.247(d)

4.6.1 Requirement

In any 100 kHz bandwidths outside the EUT pass-band, the RF power shall be at least 20dB (peak) or 30 dB (average) below that of the maximum in-band 100 kHz emissions.

4.6.2 Procedure

The procedure described in FCC Publication 558074 D01 Meas Guidance v05r02 was used. Specifically, Section 7.8.8 of ANSI C63.10:2013 for Frequency Hopping Spread Spectrum Systems was used to determine the Out-of-Band Conducted Emissions.

- Span = wide enough to capture the peak level of the in-band emission and all spurious emissions (e.g., harmonics) from the lowest frequency generated in the EUT up through the 10th harmonic.
- RBW = 100 kHz
- VBW = 3 x RBW
- Sweep = auto
- Detector function = peak
- Trace = max hold

Allow the trace to stabilize. Set the marker on the peak of any spurious emission recorded. The level displayed must comply with the limit specified in this Section.

A spectrum analyzer was connected to the antenna port of the transmitter. Analyzer Resolution Bandwidth was set to 100 kHz. For each channel investigated, the in-band and out-of-band emission measurements were performed. The out-of-band emissions were measured from 30 MHz to 26 GHz.

Tested By	Test Date
Anderson Soungpanya	November 27, 2019

4.6.3 Test Result

Refer to the following plots and out-of-band conducted spurious emissions at the Band-Edge, Table 4.1 & 4.2 for the test results:

Table 4.1

Frequency MHz	Description	Plot #
2436.000000	Scan 30 MHz – 26 GHz	4.1
2450.567868	Scan 30 MHz – 26 GHz	4.2
2463.921747	Scan 30 MHz – 26 GHz	4.3

Out-of-Band Conducted Spurious Emissions at the Band-Edge:

Table 4.2

Channel	Frequency MHz	Out-band emissions margin to In-band emissions	Plot #
0	2436.000000	Complies, Greater than 20dB	4.4
Hopping	Low Band Edge	Complies, Greater than 20dB	4.5
23	2463.921747	Complies, Greater than 20dB	4.6
Hopping	High Band Edge	Complies, Greater than 20dB	4.7

Plot 4.1
Transmitter Spurious, Low Channel

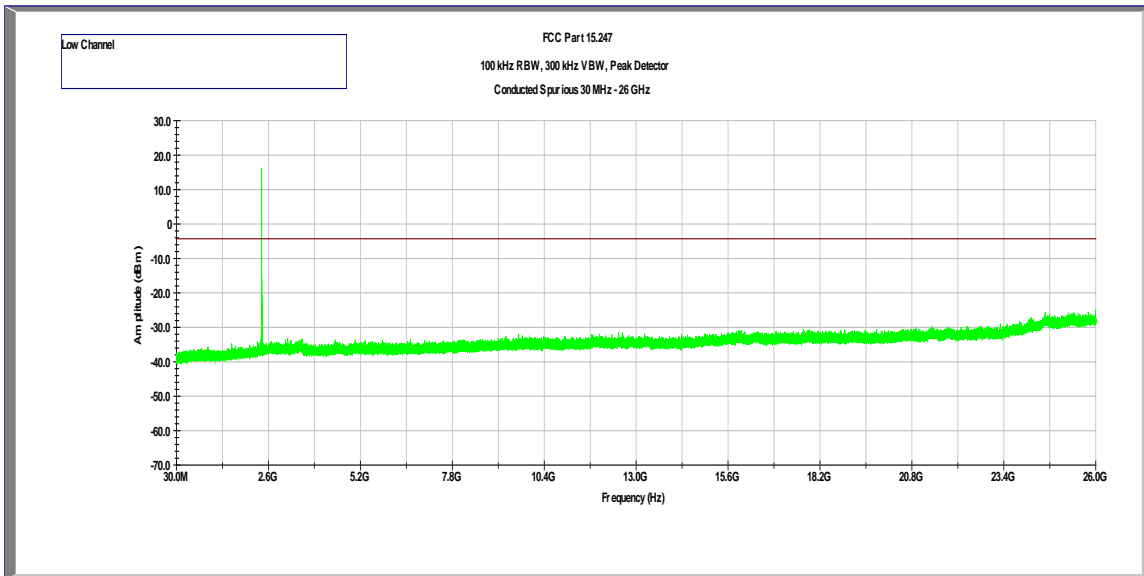

Plot 4.2
Transmitter Spurious, Middle Channel

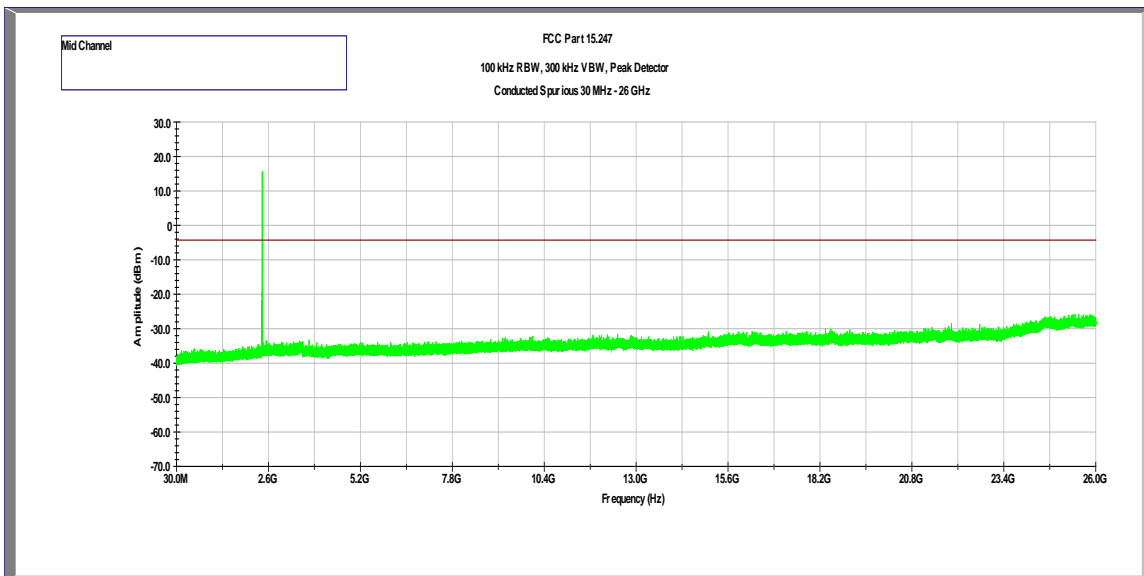

Plot 4.3
Transmitter Spurious, High Channel

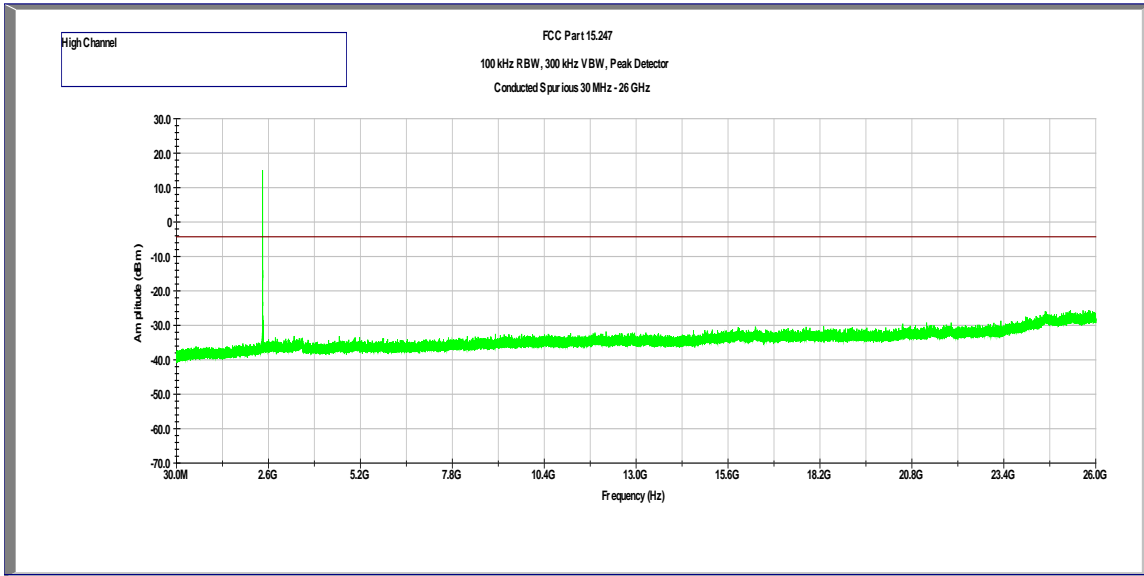

Plot 4.4
Conducted Band Edge, Low Channel

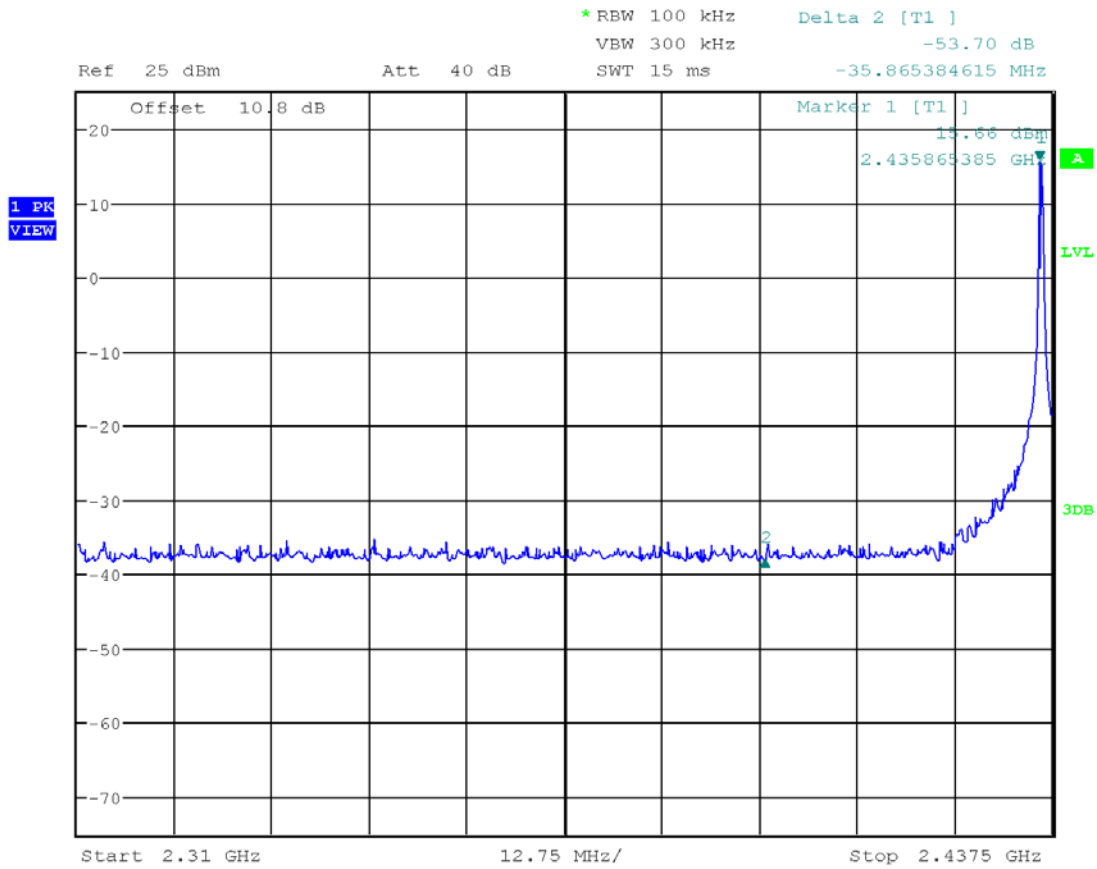

Date: 27.NOV.2019 08:55:35

Plot 4.11
Conducted Band Edge (Hopping)

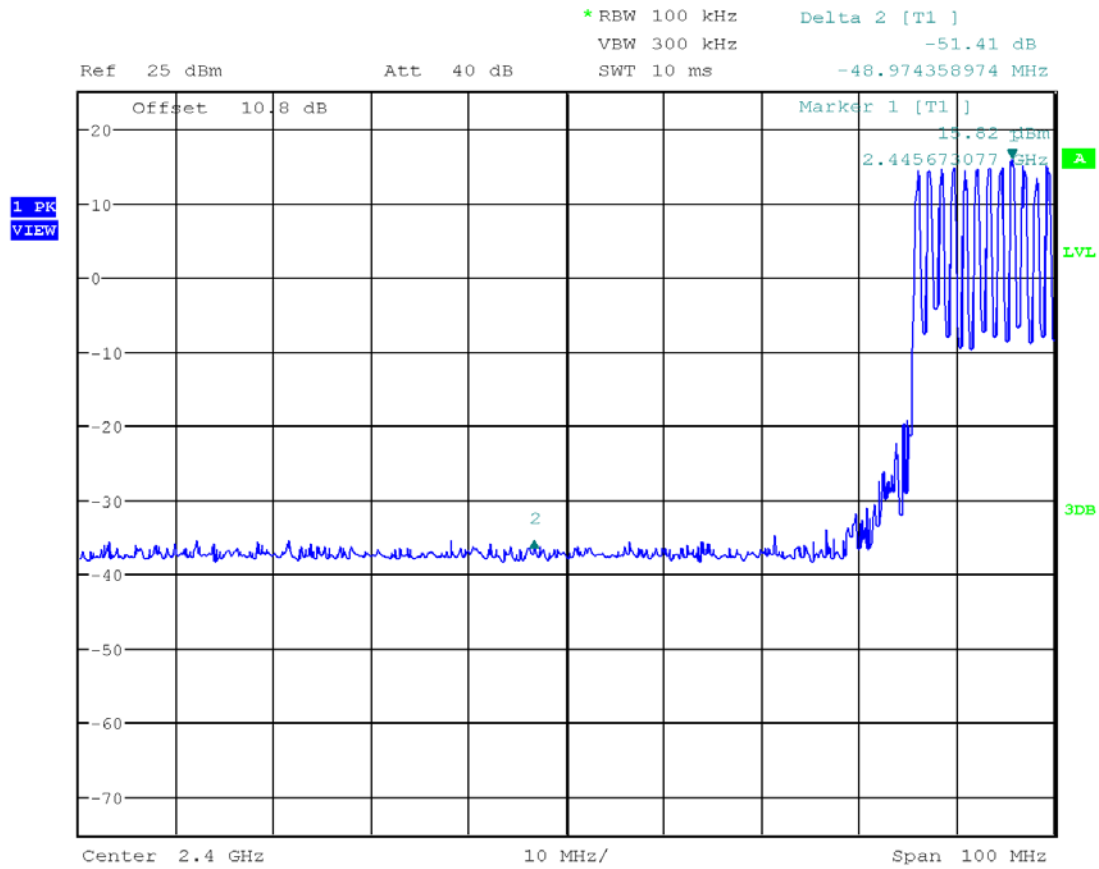

Date: 27.NOV.2019 09:15:53

Plot 4.12
Conducted Band Edge, High Channel

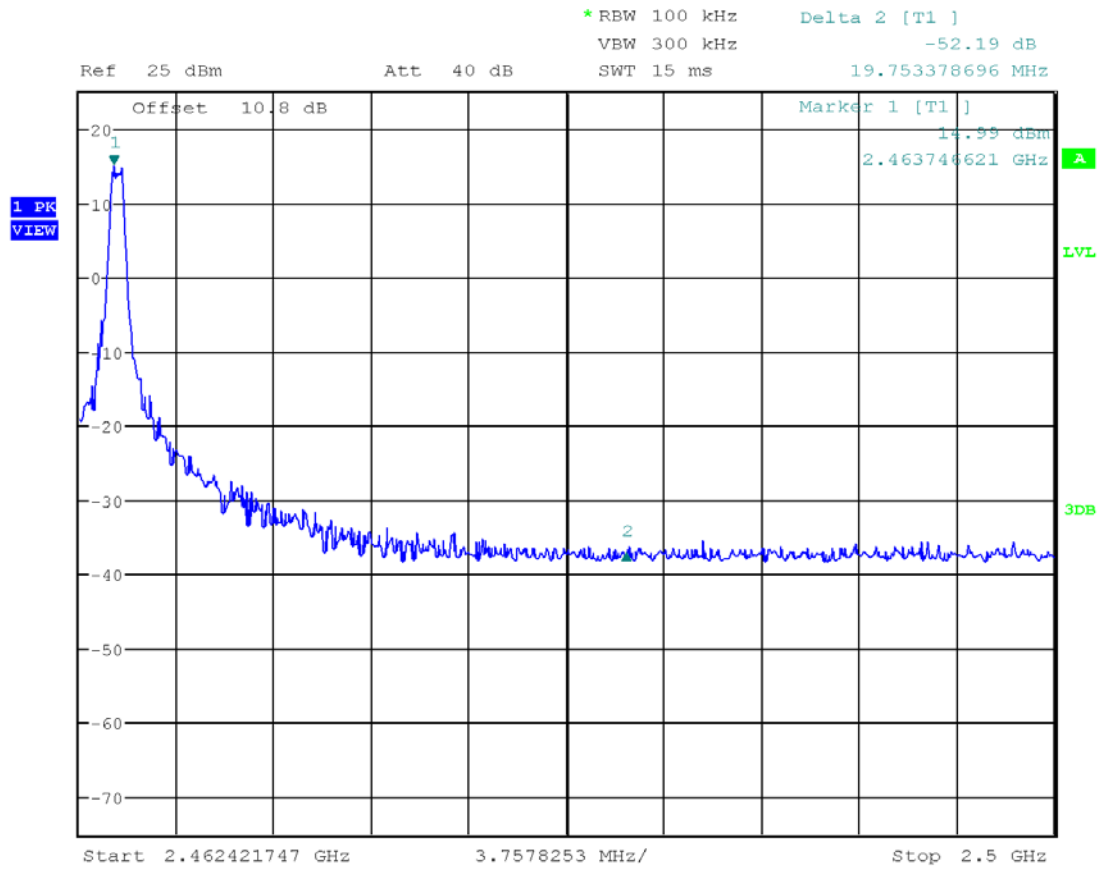

Date: 27.NOV.2019 08:58:38

Plot 4.13
Conducted Band Edge (Hopping)

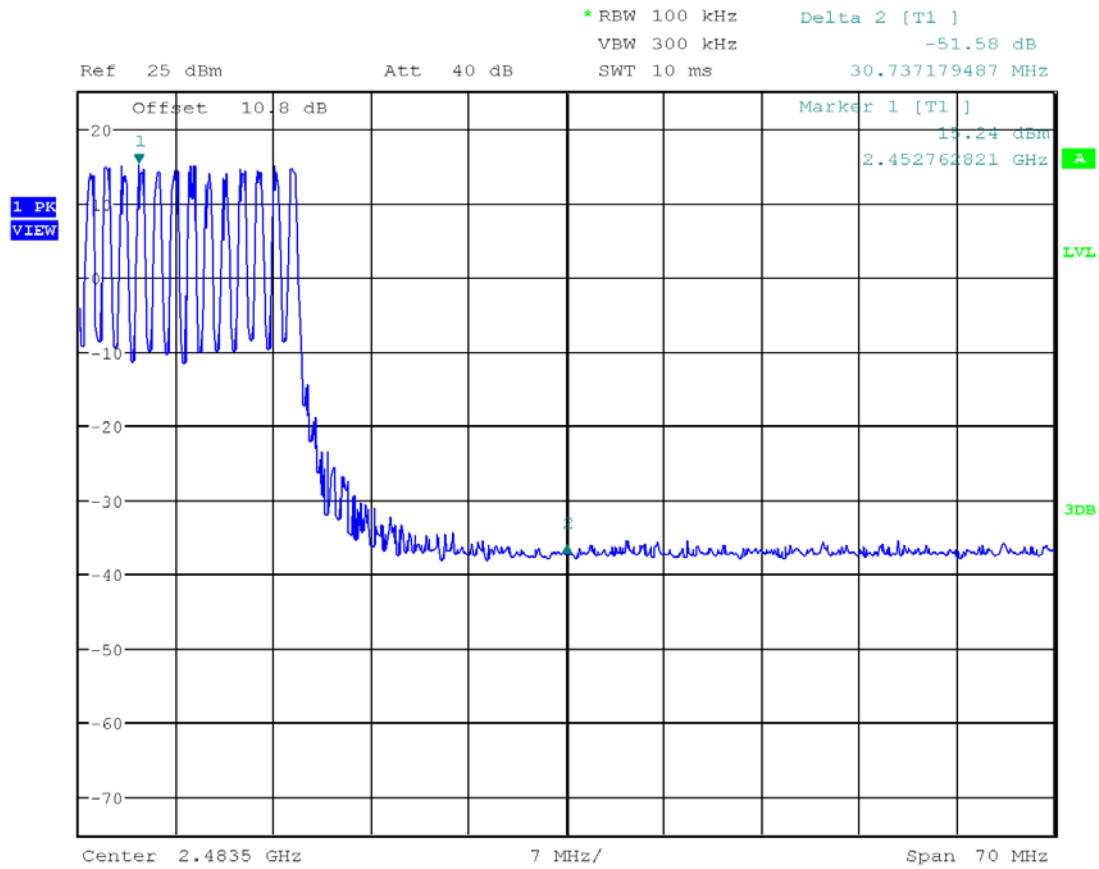

Date: 27.NOV.2019 09:13:03

Results **Complies**

4.7 Transmitter Radiated Emissions
FCC Rule 15.247(d), 15.209, 15.205

4.7.1 Requirement

Radiated emissions which fall in the restricted bands, as defined in §15.205(a), must also comply with the radiated emission limits specified in §15.209(a) (see §15.205(c)).

For out of band radiated emissions (except for frequencies in restricted bands), in any 100 kHz bandwidths outside the EUT pass-band, the RF power shall be at least 20dB (peak) or 30 dB (average) below that of the maximum in-band 100 kHz emissions.

4.7.2 Procedure

Radiated emission measurements were performed from 9kHz to 25GHz. Spectrum Analyzer Resolution Bandwidth is 100 kHz or greater for frequencies 30 MHz to 1000 MHz, 1 MHz for frequencies above 1000 MHz.

If the EUT attaches to peripherals, they are connected and operational (as typical as possible). During testing, all cables were manipulated to produce worst-case emissions. The signal is maximized through rotation. The antenna height and polarization are varied during the search for maximum signal level. The antenna height is varied from 1 to 4 meters.

Radiated emissions are taken at 3 meters for frequencies above 1 GHz & below 1 GHz.

Spurious measurements are made with a preamp from 9kHz MHz to 25 GHz.

Measurements may be made with a Peak Detector and compared to QP limits for 9kHz – 1 GHz and Average limits for 1 GHz – 25 GHz.

Radiated Spurious measurements were performed at the customer's site, specifically in their parking lot. EUT was too large and heavy to transport to Intertek's facilities. Procedure and approval were made with the FCC to proceed with these measurements. Measuring Antenna was placed evenly at 16 positions around the EUT. Measuring antennas were 3m from the EUT during measurements. See Figure 1 and test photos for further details.

Radiated Band Edge in the Restricted band were measured inside a semi anechoic chamber. The Radio Board and Antenna were removed from its host and placed on a 1.5m table for measurement.

Out-of-Band Radiated Spurious Emissions

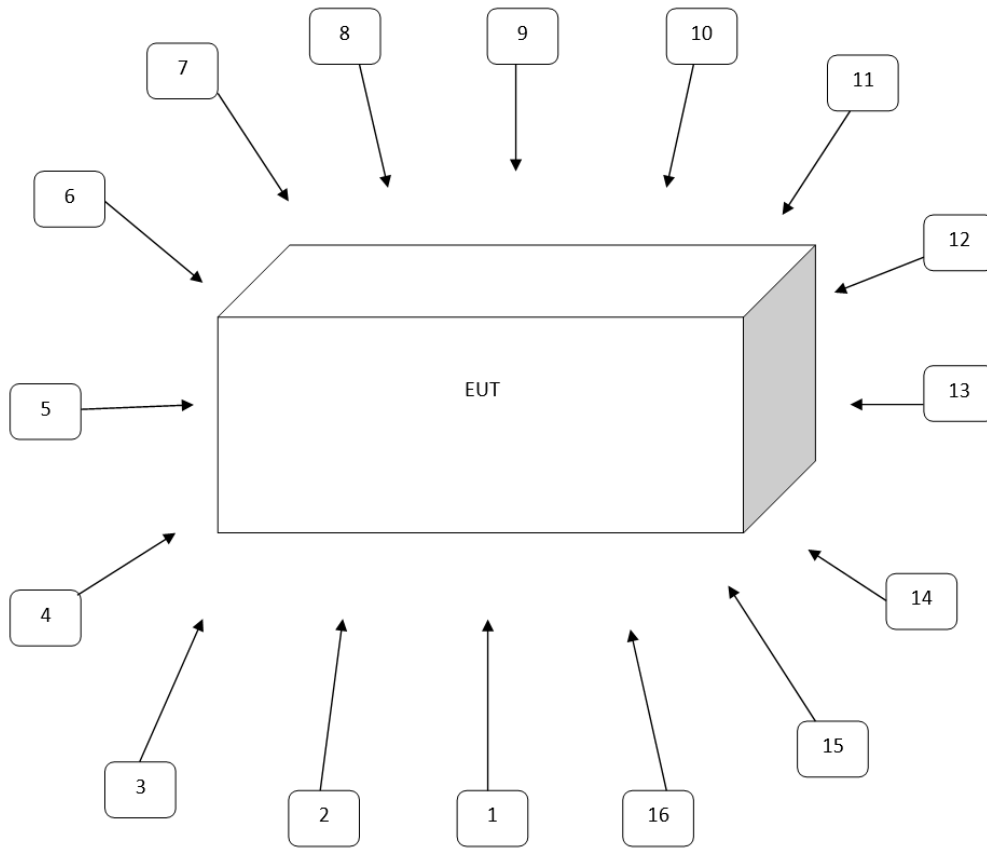

Figure 1. Measuring Antenna Positions; Separated by 22.5°

Note: Measuring Antenna Positioned 3m from the EUT.

4.7.3 Field Strength Calculation

Field Strength Calculation

The field strength is calculated by adding the Antenna Factor and Cable Factor, and subtracting the Amplifier Gain (if any) from the measured reading. The basic equation with a sample calculation is as follows:

$FS = RA + AF + CF - AG$; if measurement is performed at a distance other than specified in the rule, a Distance Correction Factor (DCF) shall be added.

Where FS = Field Strength in dB(μ V/m)

RA = Receiver Amplitude (including preamplifier) in dB(μ V); AF = Antenna Factor in dB(1/m)

CF = Cable Attenuation Factor in dB; AG = Amplifier Gain in dB

Assume a receiver reading of 52.0 dB(μ V) is obtained. The antennas factor of 7.4 dB(1/m) and cable factor of 1.6 dB is added. The amplifier gain of 29 dB is subtracted, giving field strength of 32 dB(μ V/m). This value in dB(μ V/m) was converted to its corresponding level in μ V/m.

RA = 52.0 dB(μ V)

AF = 7.4 dB(1/m)

CF = 1.6 dB

AG = 29.0 dB

$FS = 52.0 + 7.4 + 1.6 - 29.0 = 32$ dB(μ V/m).

Level in μ V/m = Common Antilogarithm [(32 dB μ V/m)/20] = 39.8 μ V/m.

4.7.4 Antenna-port conducted measurements

Antenna-port conducted measurements may also be used as an alternative to radiated measurements for demonstrating compliance in the restricted frequency bands. If conducted measurements are performed, then proper impedance matching must be ensured and an additional radiated test for cabinet/case spurious emissions is required.

4.7.5 General Procedure for conducted measurements in restricted bands

- a) Measure the conducted output power (in dBm) using the detector specified for determining quasi-peak, peak, and average conducted output power, respectively.
- b) Add the maximum transmit antenna gain (in dBi) to the measured output power level to determine the EIRP level (see 12.2.5 for guidance on determining the applicable antenna gain)
- c) Add the appropriate maximum ground reflection factor to the EIRP level (6 dB for frequencies ≤ 30 MHz, 4.7 dB for frequencies between 30 MHz and 1000 MHz, inclusive and 0 dB for frequencies > 1000 MHz).
- d) For devices with multiple antenna-ports, measure the power of each individual chain and sum the EIRP of all chains in linear terms (*e.g.*, Watts, mW).
- e) Convert the resultant EIRP level to an equivalent electric field strength using the following relationship:
 $E = \text{EIRP} - 20\log D + 104.8 + \text{DCF}$ (DCF for Average measurements)
 where:
 E = electric field strength in dB μ V/m,
 EIRP = equivalent isotropic radiated power in dBm
 D = specified measurement distance in meters.
 DCF = Duty Cycle Correction Factor
- f) Compare the resultant electric field strength level to the applicable limit.
- g) Perform radiated spurious emission test

4.7.6 Test Results

Tested By	Test Date
Anderson Soungpanya	September 15 – October 14, 2020

These measurements were performed with Antenna in place.

4.7.6 Test Results (Continued)

Test Results: 15.209/15.205 Radiated Restricted Band Emissions

Radiated Band Edge at the Restricted Band – Tx @ Low Channel, Peak

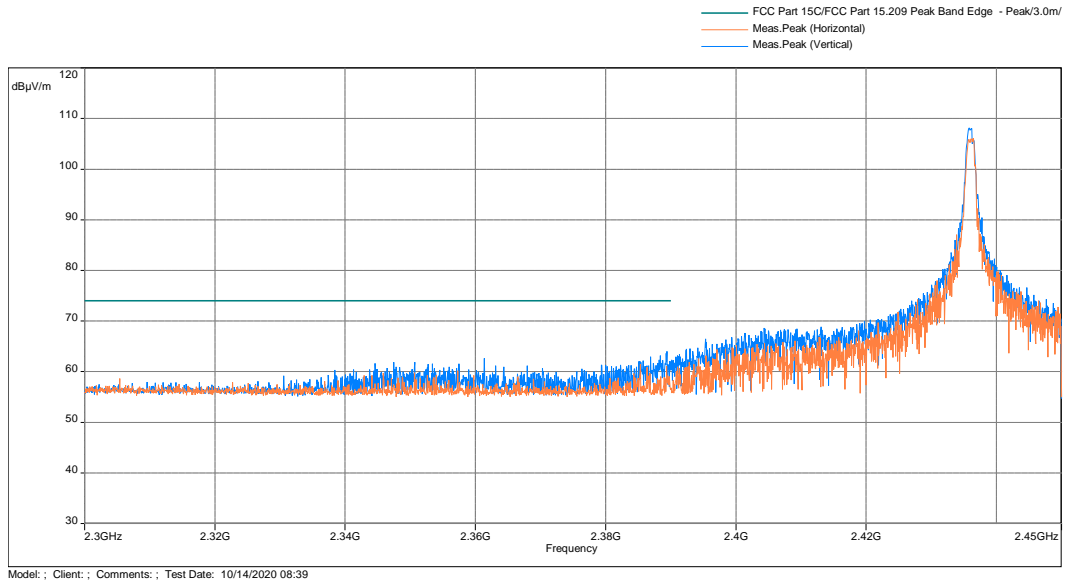

Radiated Band Edge at the Restricted Band – Tx @ Low Channel, Average

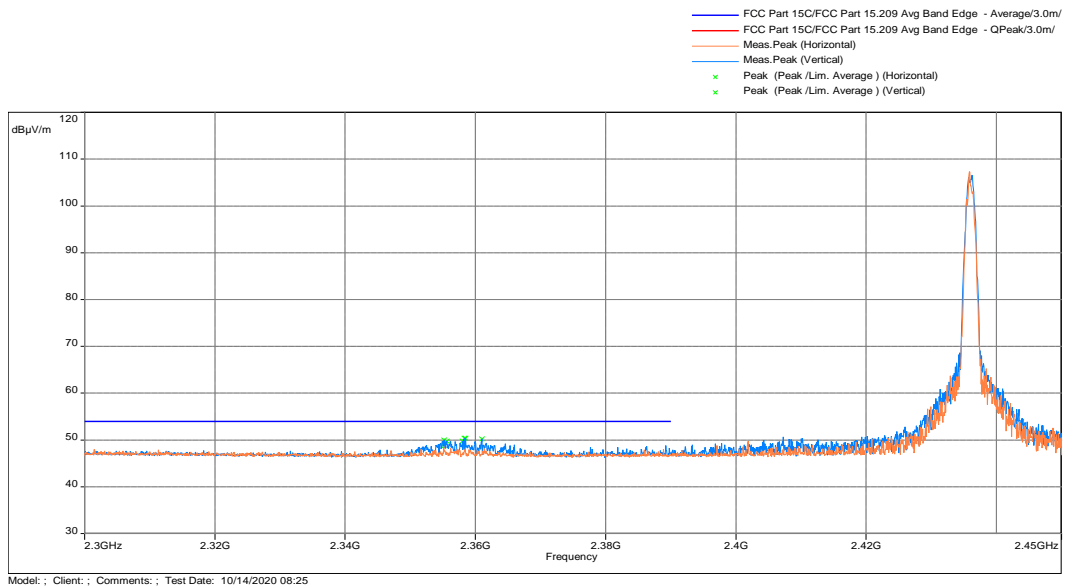

Frequency (MHz)	Peak (dBµV/m)	Lim. Average (dBµV/m)	Peak-Lim (dB)	Height (m)	Angle (°)	Comment	Correction (dB)
2358.493	50.37	54	-3.63	1.52	169.75	Vertical	31.4

Radiated Band Edge at the Restricted Band – Tx @ High Channel, Peak

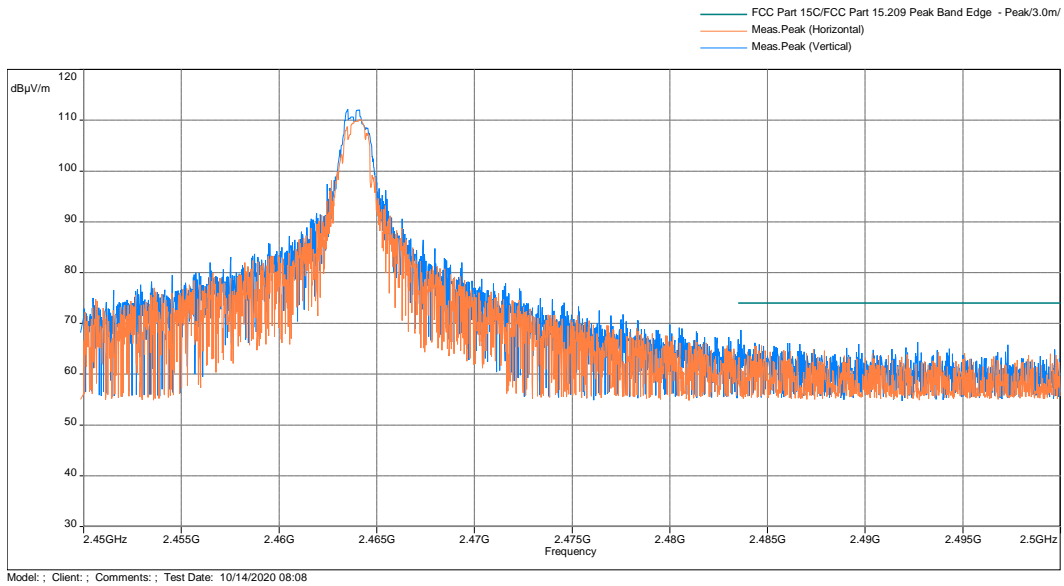

Radiated Band Edge at the Restricted Band – Tx @ High Channel, Average

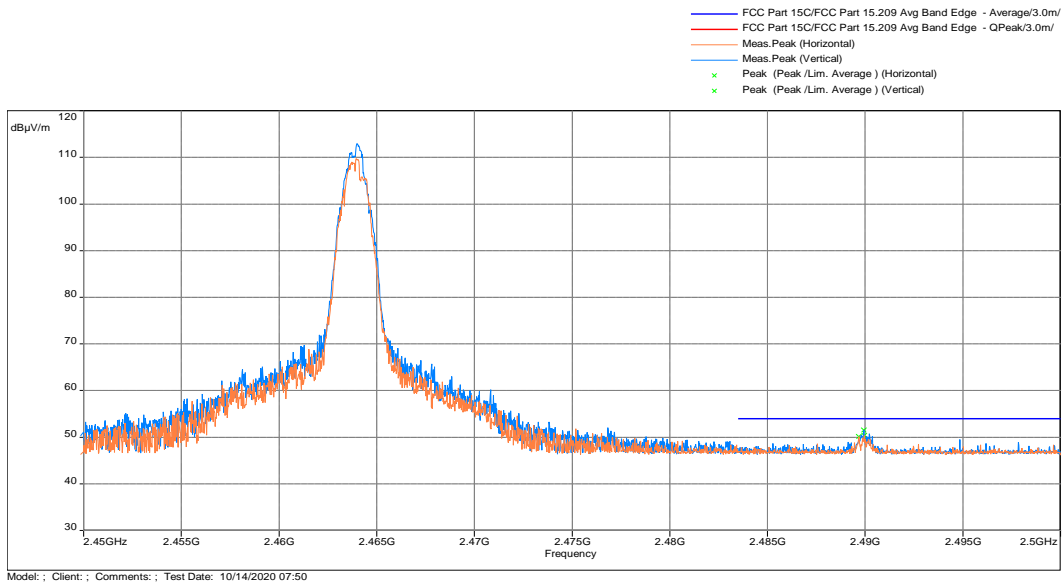

Frequency (MHz)	Peak (dBµV/m)	Lim. Average (dBµV/m)	Peak-Lim (dB)	Height (m)	Angle (°)	Comment	Correction (dB)
2489.933	51.51	54	-2.49	2.48	127.25	Vertical	31.26

Radiated Band Edge Setup Pictures

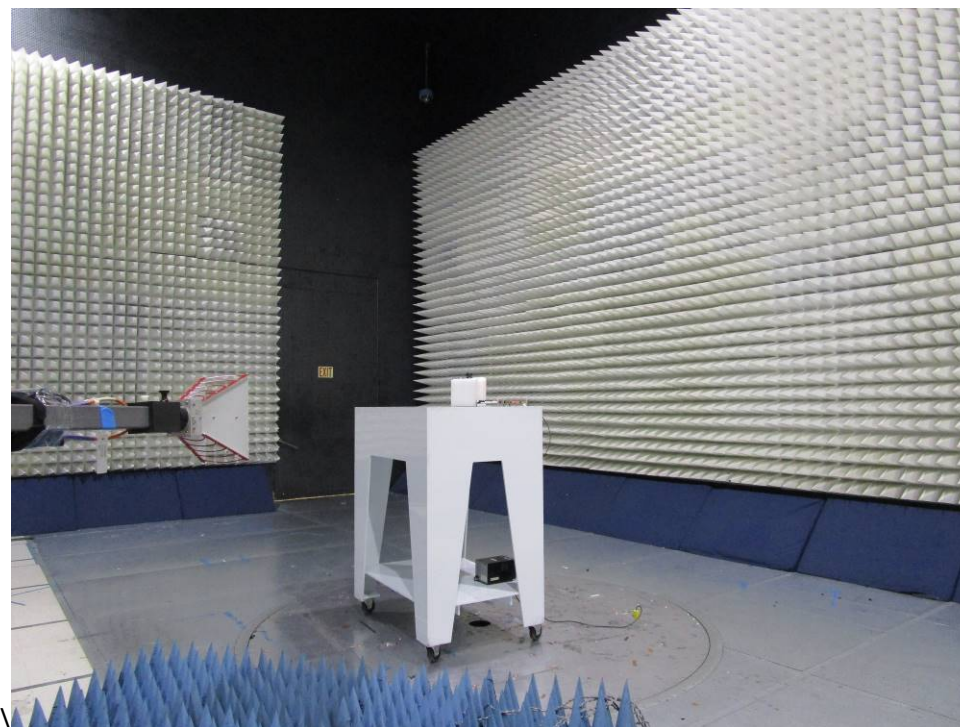
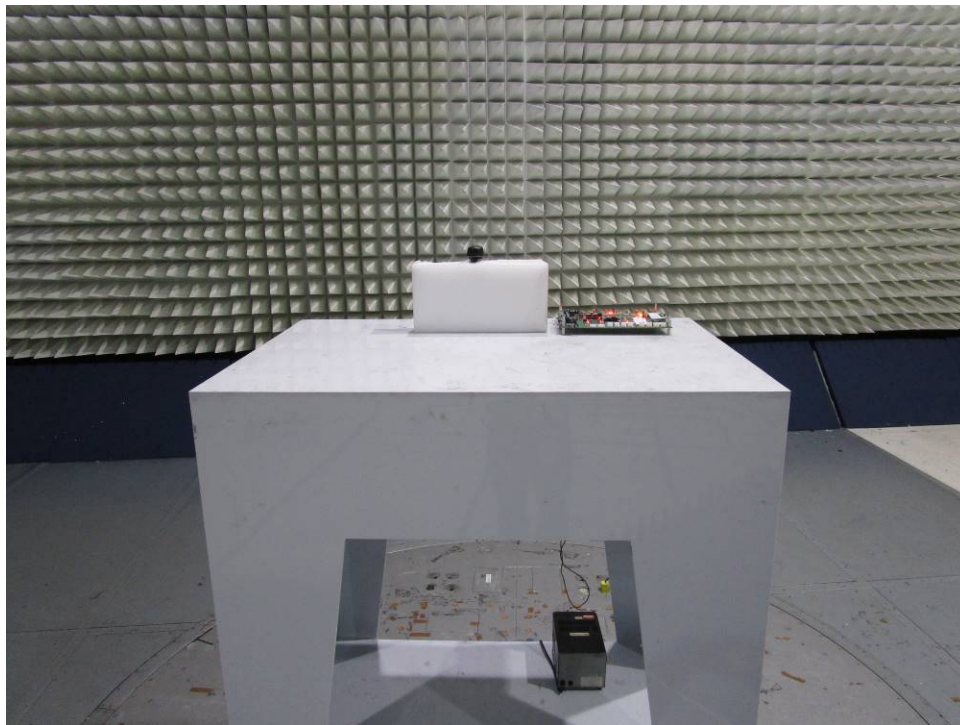

Out-of-Band Radiated Spurious Emissions

Test Results: Worst Case Spurious from Antenna Positions 1 – 4.
15.209 Radiated Spurious Emissions Low Channel, Tx at 2436 MHz

Freq. (MHz)	Ant. Polarity	Raw Amp. @ 3m dBuV/m	Preamp dB	Ant. Factor dB/m	Cable Loss dB	Field Strength Final Amp @ 3m dBuV/m	Ant. Position	Ant Height m	Detector	Limit @3 m dBuV/m	Margin dB
10.004	Par	44.75	32.02	35.10	0.20	48.03	1	1.00	Peak	69.50	-21.47
15.027	Perp	41.94	32.02	34.50	0.26	44.68	4	1.00	Peak	69.50	-24.82
18.130	Perp	42.51	32.02	34.79	0.32	45.60	2	1.00	Peak	69.50	-23.90
249.000	V	44.51	31.92	16.60	1.17	30.36	1	2.63	Peak	46.00	-15.64
327.000	H	50.54	31.93	18.40	1.34	38.35	1	1.43	Peak	46.00	-7.65
331.000	H	51.67	31.93	18.50	1.34	39.58	1	1.59	Peak	46.00	-6.42
400.000	V	48.62	31.97	20.30	1.50	38.45	2	2.16	Peak	46.00	-7.55
1721.800	V	64.40	45.30	25.35	3.06	47.50	1	1.55	Peak	54.00	-6.50
3681.100	H	58.50	44.12	30.86	4.56	49.79	1	1.43	Peak	54.00	-4.21
4872.000	V	52.24	43.71	32.80	5.29	46.62	1	2.20	Peak	74.00	-27.38
4872.000	V	38.20	43.71	32.80	5.29	32.58	1	2.20	Avg	54.00	-21.42
7308.000	H	49.41	43.94	37.43	6.57	49.47	1	1.00	Peak	74.00	-24.53
7308.000	H	35.05	43.94	37.43	6.57	35.11	1	1.00	Avg	54.00	-18.89
9744.000	H	50.98	44.22	38.02	7.61	52.39	1	1.00	Peak	74.00	-21.61
9744.000	H	36.57	44.22	38.02	7.61	37.98	1	1.00	Avg	54.00	-16.02
12180.000	H	50.37	44.53	38.24	8.65	52.73	1	1.00	Peak	74.00	-21.27
12180.000	H	35.43	44.53	38.24	8.65	37.79	1	1.00	Avg	54.00	-16.21
14616.000	H	49.86	46.15	40.33	9.60	53.63	1	1.00	Peak	74.00	-20.37
14616.000	H	35.26	46.15	40.33	9.60	39.03	1	1.00	Avg	54.00	-14.97
17052.000	H	50.08	44.11	41.01	10.40	57.39	1	1.00	Peak	74.00	-16.61
17052.000	H	36.02	44.11	41.01	10.40	43.33	1	1.00	Avg	54.00	-10.67

Note: Radiated emission measurements were performed up to 25GHz. No Emissions were identified when scanned from 18-25 GHz

Note: FS = Raw – Preamp Factor + Antenna Factor + Cable Factor

Test Results: Worst Case Spurious from Antenna Positions 5 – 8.
15.209 Radiated Spurious Emissions Low Channel, Tx at 2436 MHz

Freq. (MHz)	Ant. Polarity	Raw Amp. @ 3m dBuV/m	Preamp dB	Ant. Factor dB/m	Cable Loss dB	Field Strength Final Amp @ 3m dBuV/m	Ant. Position	Ant Height m	Detector	Limit @3 m dBuV/m	Margin dB
5.986	Perp	37.53	32.02	35.60	0.24	41.35	7	1.00	Peak	69.50	-28.15
11.726	Perp	28.84	32.02	34.65	0.20	31.68	6	1.00	Peak	69.50	-37.82
12.013	Par	42.66	32.02	34.60	0.21	45.44	6	1.00	Peak	69.50	-24.06
249.000	V	51.76	31.92	16.60	1.17	37.61	6	1.93	Peak	46.00	-8.39
327.000	H	53.80	31.93	18.40	1.34	41.61	7	1.20	Peak	46.00	-4.39
331.000	H	49.58	31.93	18.50	1.34	37.49	6	2.77	Peak	46.00	-8.51
400.000	V	46.25	31.97	20.30	1.50	36.08	7	2.68	Peak	46.00	-9.92
1721.800	V	60.95	45.30	25.35	3.06	44.05	6	1.90	Peak	54.00	-9.95
3681.100	H	59.70	44.12	30.86	4.56	50.99	6	1.35	Peak	54.00	-3.01
4872.000	V	53.94	43.71	32.80	5.29	48.32	6	2.35	Peak	74.00	-25.68
4872.000	V	37.58	43.71	32.80	5.29	31.96	6	2.35	Avg	54.00	-22.04
7308.000	H	51.96	43.94	37.43	6.57	52.02	5	2.11	Peak	74.00	-21.98
7308.000	H	35.58	43.94	37.43	6.57	35.63	5	2.11	Avg	54.00	-18.37
9744.000	H	50.59	44.22	38.02	7.61	52.00	5	1.00	Peak	74.00	-22.00
9744.000	H	36.72	44.22	38.02	7.61	38.13	5	1.00	Avg	54.00	-15.87
12180.000	H	50.80	44.53	38.24	8.65	53.16	5	1.00	Peak	74.00	-20.84
12180.000	H	35.58	44.53	38.24	8.65	37.94	5	1.00	Avg	54.00	-16.06
14616.000	H	51.47	46.15	40.33	9.60	55.25	5	1.00	Peak	74.00	-18.75
14616.000	H	35.12	46.15	40.33	9.60	38.89	5	1.00	Avg	54.00	-15.11
17052.000	H	50.81	44.11	41.01	10.40	58.12	5	1.00	Peak	74.00	-15.88
17052.000	H	36.91	44.11	41.01	10.40	44.22	5	1.00	Avg	54.00	-9.78

Note: Radiated emission measurements were performed up to 25GHz. No Emissions were identified when scanned from 18-25 GHz

Note: FS = Raw – Preamp Factor + Antenna Factor + Cable Factor

Test Results: Worst Case Spurious from Antenna Positions 9 – 12.
15.209 Radiated Spurious Emissions Low Channel, Tx at 2436 MHz

Freq. (MHz)	Ant. Polarity	Raw Amp. @ 3m dBuV/m	Preamp dB	Ant. Factor dB/m	Cable Loss dB	Field Strength Final Amp @ 3m dBuV/m	Ant. Position	Ant Height m	Detector	Limit @3 m dBuV/m	Margin dB
10.004	Par	48.27	32.02	35.10	0.20	51.55	10	1.00	Peak	69.50	-17.95
11.487	Perp	43.54	32.02	34.70	0.20	46.42	12	1.00	Peak	69.50	-23.08
13.544	Par	42.91	32.02	34.38	0.23	45.50	10	1.00	Peak	69.50	-24.00
249.000	V	54.21	31.92	16.60	1.17	40.06	11	1.71	Peak	46.00	-5.94
327.000	H	54.83	31.93	18.40	1.34	42.64	12	1.85	Peak	46.00	-3.36
331.000	H	52.22	31.93	18.50	1.34	40.13	12	1.30	Peak	46.00	-5.87
400.000	V	42.86	31.97	20.30	1.50	32.69	11	2.21	Peak	46.00	-13.31
1721.800	V	63.57	45.30	25.35	3.06	46.67	12	2.94	Peak	54.00	-7.33
3681.100	H	57.53	44.12	30.86	4.56	48.82	12	1.12	Peak	54.00	-5.18
4872.000	V	52.95	43.71	32.80	5.29	47.34	11	2.51	Peak	74.00	-26.66
4872.000	V	38.76	43.71	32.80	5.29	33.14	11	2.51	Avg	54.00	-20.86
7308.000	H	51.93	43.94	37.43	6.57	51.99	12	3.21	Peak	74.00	-22.01
7308.000	H	36.67	43.94	37.43	6.57	36.73	12	3.21	Avg	54.00	-17.27
9744.000	H	50.29	44.22	38.02	7.61	51.71	12	1.00	Peak	74.00	-22.29
9744.000	H	36.30	44.22	38.02	7.61	37.71	12	1.00	Avg	54.00	-16.29
12180.000	H	50.47	44.53	38.24	8.65	52.83	12	1.00	Peak	74.00	-21.17
12180.000	H	35.75	44.53	38.24	8.65	38.11	12	1.00	Avg	54.00	-15.89
14616.000	H	51.01	46.15	40.33	9.60	54.78	12	1.00	Peak	74.00	-19.22
14616.000	H	35.11	46.15	40.33	9.60	38.88	12	1.00	Avg	54.00	-15.12
17052.000	H	51.70	44.11	41.01	10.40	59.01	12	1.00	Peak	74.00	-14.99
17052.000	H	36.09	44.11	41.01	10.40	43.39	12	1.00	Avg	54.00	-10.61

Note: Radiated emission measurements were performed up to 25GHz. No Emissions were identified when scanned from 18-25 GHz

Note: FS = Raw – Preamp Factor + Antenna Factor + Cable Factor

Test Results: Worst Case Spurious from Antenna Positions 13 – 16.
15.209 Radiated Spurious Emissions Low Channel, Tx at 2436 MHz

Freq. (MHz)	Ant. Polarity	Raw Amp. @ 3m dBuV/m	Preamp dB	Ant. Factor dB/m	Cable Loss dB	Field Strength Final Amp @ 3m dBuV/m	Ant. Position	Ant Height m	Detector	Limit @3 m dBuV/m	Margin dB
5.986	Perp	47.37	32.02	35.60	0.24	51.19	14	1.00	Peak	69.50	-18.31
18.232	Par	40.29	32.02	34.79	0.32	43.37	15	1.00	Peak	69.50	-26.13
29.952	Par	48.70	32.01	24.48	0.40	41.57	16	1.00	Peak	69.50	-27.93
249.000	V	55.63	31.92	16.60	1.17	41.48	16	2.09	Peak	46.00	-4.52
327.000	H	55.49	31.93	18.40	1.34	43.30	16	2.55	Peak	46.00	-2.70
331.000	H	53.31	31.93	18.50	1.34	41.22	16	1.71	Peak	46.00	-4.78
400.000	V	47.16	31.97	20.30	1.50	36.99	15	2.77	Peak	46.00	-9.01
1721.800	V	64.12	45.30	25.35	3.06	47.22	15	1.17	Peak	54.00	-6.78
3681.100	H	59.56	44.12	30.86	4.56	50.85	16	1.23	Peak	54.00	-3.15
4872.000	V	52.40	43.71	32.80	5.29	46.78	14	2.74	Peak	74.00	-27.22
4872.000	V	37.33	43.71	32.80	5.29	31.72	14	2.74	Avg	54.00	-22.28
7308.000	H	50.10	43.94	37.43	6.57	50.16	14	1.00	Peak	74.00	-23.84
7308.000	H	35.82	43.94	37.43	6.57	35.87	14	1.00	Avg	54.00	-18.13
9744.000	H	50.12	44.22	38.02	7.61	51.53	16	1.00	Peak	74.00	-22.47
9744.000	H	35.39	44.22	38.02	7.61	36.80	16	1.00	Avg	54.00	-17.20
12180.000	H	50.83	44.53	38.24	8.65	53.19	16	1.00	Peak	74.00	-20.81
12180.000	H	36.22	44.53	38.24	8.65	38.58	16	1.00	Avg	54.00	-15.42
14616.000	H	50.76	46.15	40.33	9.60	54.53	16	1.00	Peak	74.00	-19.47
14616.000	H	35.78	46.15	40.33	9.60	39.56	16	1.00	Avg	54.00	-14.44
17052.000	H	51.73	44.11	41.01	10.40	59.04	16	1.00	Peak	74.00	-14.96
17052.000	H	35.82	44.11	41.01	10.40	43.13	16	1.00	Avg	54.00	-10.87

Note: Radiated emission measurements were performed up to 25GHz. No Emissions were identified when scanned from 18-25 GHz

Note: FS = Raw – Preamp Factor + Antenna Factor + Cable Factor

Test Results: Worst Case Spurious from Antenna Positions 1 – 4.
15.209 Radiated Spurious Emissions Mid Channel, Tx at 2450.567868 MHz

Freq. (MHz)	Ant. Polarity	Raw Amp. @ 3m dBuV/m	Preamp dB	Ant. Factor dB/m	Cable Loss dB	Field Strength Final Amp @ 3m dBuV/m	Ant. Position	Ant Height m	Detector	Limit @3 m dBuV/m	Margin dB
10.004	Par	45.43	32.02	35.10	0.20	48.71	1	1.00	Peak	69.50	-20.79
15.027	Perp	43.46	32.02	34.50	0.26	46.20	3	1.00	Peak	69.50	-23.30
18.130	Perp	44.45	32.02	34.79	0.32	47.54	2	1.00	Peak	69.50	-21.96
249.000	V	44.72	31.92	16.60	1.17	30.57	1	2.66	Peak	46.00	-15.43
327.000	H	51.22	31.93	18.40	1.34	39.03	1	2.63	Peak	46.00	-6.97
331.000	H	52.48	31.93	18.50	1.34	40.39	1	1.35	Peak	46.00	-5.61
400.000	V	49.02	31.97	20.30	1.50	38.85	2	2.19	Peak	46.00	-7.15
1721.800	V	65.02	45.30	25.35	3.06	48.12	1	1.05	Peak	54.00	-5.88
3681.100	H	60.10	44.12	30.86	4.56	51.39	1	1.01	Peak	54.00	-2.61
4901.136	V	53.41	43.71	32.83	5.31	47.85	1	2.97	Peak	74.00	-26.15
4901.136	V	37.33	43.71	32.83	5.31	31.76	1	2.97	Avg	54.00	-22.24
7351.704	H	51.45	43.95	37.48	6.59	51.57	1	1.95	Peak	74.00	-22.43
7351.704	H	36.90	43.95	37.48	6.59	37.02	1	1.95	Avg	54.00	-16.98
9802.272	H	50.39	44.23	38.09	7.63	51.88	1	1.00	Peak	74.00	-22.12
9802.272	H	35.86	44.23	38.09	7.63	37.35	1	1.00	Avg	54.00	-16.65
12252.840	H	51.51	44.58	38.29	8.68	53.89	1	1.00	Peak	74.00	-20.11
12252.840	H	35.27	44.58	38.29	8.68	37.65	1	1.00	Avg	54.00	-16.35
14703.408	H	51.80	46.08	40.17	9.63	55.53	1	1.00	Peak	74.00	-18.47
14703.408	H	36.62	46.08	40.17	9.63	40.35	1	1.00	Avg	54.00	-13.65
17153.976	H	50.23	44.08	41.26	10.46	57.87	1	1.00	Peak	74.00	-16.13
17153.976	H	36.41	44.08	41.26	10.46	44.06	1	1.00	Avg	54.00	-9.94

Note: Radiated emission measurements were performed up to 25GHz. No Emissions were identified when scanned from 18-25 GHz

Note: FS = Raw – Preamp Factor + Antenna Factor + Cable Factor

Test Results: Worst Case Spurious from Antenna Positions 1 – 4.
15.209 Radiated Spurious Emissions Mid Channel, Tx at 2450.567868 MHz

Freq. (MHz)	Ant. Polarity	Raw Amp. @ 3m dBuV/m	Preamp dB	Ant. Factor dB/m	Cable Loss dB	Field Strength Final Amp @ 3m dBuV/m	Ant. Position	Ant Height m	Detector	Limit @3 m dBuV/m	Margin dB
5.986	Perp	37.53	32.02	35.60	0.24	41.35	7	1.00	Peak	69.50	-28.15
11.726	Perp	28.84	32.02	34.65	0.20	31.68	6	1.00	Peak	69.50	-37.82
12.013	Par	42.66	32.02	34.60	0.21	45.44	6	1.00	Peak	69.50	-24.06
249.000	V	51.76	31.92	16.60	1.17	37.61	6	1.93	Peak	46.00	-8.39
327.000	H	53.80	31.93	18.40	1.34	41.61	7	1.20	Peak	46.00	-4.39
331.000	H	49.58	31.93	18.50	1.34	37.49	6	2.77	Peak	46.00	-8.51
400.000	V	46.25	31.97	20.30	1.50	36.08	7	2.68	Peak	46.00	-9.92
1721.800	V	60.95	45.30	25.35	3.06	44.05	6	1.90	Peak	54.00	-9.95
3681.100	H	59.70	44.12	30.86	4.56	50.99	6	1.35	Peak	54.00	-3.01
4872.000	V	53.94	43.71	32.80	5.29	48.32	6	2.26	Peak	74.00	-25.68
4872.000	V	37.58	43.71	32.80	5.29	31.96	6	2.26	Avg	54.00	-22.04
7308.000	H	51.96	43.94	37.43	6.57	52.02	5	1.45	Peak	74.00	-21.98
7308.000	H	35.58	43.94	37.43	6.57	35.63	5	1.45	Avg	54.00	-18.37
9744.000	H	50.59	44.22	38.02	7.61	52.00	5	1.00	Peak	74.00	-22.00
9744.000	H	36.72	44.22	38.02	7.61	38.13	5	1.00	Avg	54.00	-15.87
12180.000	H	50.80	44.53	38.24	8.65	53.16	5	1.00	Peak	74.00	-20.84
12180.000	H	35.58	44.53	38.24	8.65	37.94	5	1.00	Avg	54.00	-16.06
14616.000	H	51.47	46.15	40.33	9.60	55.25	5	1.00	Peak	74.00	-18.75
14616.000	H	35.12	46.15	40.33	9.60	38.89	5	1.00	Avg	54.00	-15.11
17052.000	H	50.81	44.11	41.01	10.40	58.12	5	1.00	Peak	74.00	-15.88
17052.000	H	36.91	44.11	41.01	10.40	44.22	5	1.00	Avg	54.00	-9.78

Note: Radiated emission measurements were performed up to 25GHz. No Emissions were identified when scanned from 18-25 GHz

Note: FS = Raw – Preamp Factor + Antenna Factor + Cable Factor

Test Results: Worst Case Spurious from Antenna Positions 5 – 8.
15.209 Radiated Spurious Emissions Mid Channel, Tx at 2450.567868 MHz

Freq. (MHz)	Ant. Polarity	Raw Amp. @ 3m dBuV/m	Preamp dB	Ant. Factor dB/m	Cable Loss dB	Field Strength Final Amp @ 3m dBuV/m	Ant. Position	Ant Height m	Detector	Limit @3 m dBuV/m	Margin dB
5.986	Perp	37.92	32.02	35.60	0.24	41.74	7	1.00	Peak	69.50	-27.76
11.726	Perp	29.67	32.02	34.65	0.20	32.51	6	1.00	Peak	69.50	-36.99
12.013	Par	43.17	32.02	34.60	0.21	45.95	6	1.00	Peak	69.50	-23.55
249.000	V	52.84	31.92	16.60	1.17	38.69	6	1.55	Peak	46.00	-7.31
327.000	H	55.38	31.93	18.40	1.34	43.19	7	2.38	Peak	46.00	-2.81
331.000	H	51.30	31.93	18.50	1.34	39.21	6	1.48	Peak	46.00	-6.79
400.000	V	46.61	31.97	20.30	1.50	36.44	7	1.69	Peak	46.00	-9.56
1721.800	V	61.79	45.30	25.35	3.06	44.89	6	2.88	Peak	54.00	-9.11
3681.100	H	60.26	44.12	30.86	4.56	51.55	6	2.81	Peak	54.00	-2.45
4901.136	V	51.61	43.71	32.83	5.31	46.05	7	2.15	Peak	74.00	-27.95
4901.136	V	37.37	43.71	32.83	5.31	31.80	7	2.15	Avg	54.00	-22.20
7351.704	H	50.97	43.95	37.48	6.59	51.09	6	3.74	Peak	74.00	-22.91
7351.704	H	36.62	43.95	37.48	6.59	36.74	6	3.74	Avg	54.00	-17.26
9802.272	H	51.51	44.23	38.09	7.63	53.01	5	1.00	Peak	74.00	-20.99
9802.272	H	35.00	44.23	38.09	7.63	36.50	5	1.00	Avg	54.00	-17.50
12252.840	H	51.74	44.58	38.29	8.68	54.12	5	1.00	Peak	74.00	-19.88
12252.840	H	36.18	44.58	38.29	8.68	38.57	5	1.00	Avg	54.00	-15.43
14703.408	H	50.84	46.08	40.17	9.63	54.57	5	1.00	Peak	74.00	-19.43
14703.408	H	35.47	46.08	40.17	9.63	39.20	5	1.00	Avg	54.00	-14.80
17153.976	H	50.20	44.08	41.26	10.46	57.85	5	1.00	Peak	74.00	-16.15
17153.976	H	35.76	44.08	41.26	10.46	43.40	5	1.00	Avg	54.00	-10.60

Note: Radiated emission measurements were performed up to 25GHz. No Emissions were identified when scanned from 18-25 GHz

Note: FS = Raw – Preamp Factor + Antenna Factor + Cable Factor

Test Results: Worst Case Spurious from Antenna Positions 9 – 12.
15.209 Radiated Spurious Emissions Mid Channel, Tx at 2450.567868 MHz

Freq. (MHz)	Ant. Polarity	Raw Amp. @ 3m dBuV/m	Preamp dB	Ant. Factor dB/m	Cable Loss dB	Field Strength Final Amp @ 3m dBuV/m	Ant. Position	Ant Height m	Detector	Limit @3 m dBuV/m	Margin dB
10.004	Par	49.10	32.02	35.10	0.20	52.38	10	1.00	Peak	69.50	-17.12
11.487	Perp	43.71	32.02	34.70	0.20	46.59	12	1.00	Peak	69.50	-22.91
13.544	Par	43.72	32.02	34.38	0.23	46.31	10	1.00	Peak	69.50	-23.19
249.000	V	55.83	31.92	16.60	1.17	41.68	11	1.15	Peak	46.00	-4.32
327.000	H	54.97	31.93	18.40	1.34	42.78	12	1.30	Peak	46.00	-3.22
331.000	H	52.82	31.93	18.50	1.34	40.73	12	1.36	Peak	46.00	-5.27
400.000	V	43.76	31.97	20.30	1.50	33.59	11	2.07	Peak	46.00	-12.41
1721.800	V	65.24	45.30	25.35	3.06	48.34	12	2.86	Peak	54.00	-5.66
3681.100	H	57.53	44.12	30.86	4.56	48.82	12	1.73	Peak	54.00	-5.18
4901.136	V	54.36	43.71	32.83	5.31	48.80	11	2.63	Peak	74.00	-25.20
4901.136	V	37.86	43.71	32.83	5.31	32.29	11	2.63	Avg	54.00	-21.71
7351.704	H	50.65	43.95	37.48	6.59	50.76	10	1.89	Peak	74.00	-23.24
7351.704	H	36.26	43.95	37.48	6.59	36.37	10	1.89	Avg	54.00	-17.63
9802.272	H	51.17	44.23	38.09	7.63	52.67	12	1.00	Peak	74.00	-21.33
9802.272	H	36.08	44.23	38.09	7.63	37.58	12	1.00	Avg	54.00	-16.42
12252.840	H	51.41	44.58	38.29	8.68	53.79	12	1.00	Peak	74.00	-20.21
12252.840	H	36.96	44.58	38.29	8.68	39.35	12	1.00	Avg	54.00	-14.65
14703.408	H	50.32	46.08	40.17	9.63	54.05	12	1.00	Peak	74.00	-19.95
14703.408	H	36.26	46.08	40.17	9.63	39.99	12	1.00	Avg	54.00	-14.01
17153.976	H	50.46	44.08	41.26	10.46	58.11	12	1.00	Peak	74.00	-15.89
17153.976	H	36.29	44.08	41.26	10.46	43.93	12	1.00	Avg	54.00	-10.07

Note: Radiated emission measurements were performed up to 25GHz. No Emissions were identified when scanned from 18-25 GHz

Note: FS = Raw – Preamp Factor + Antenna Factor + Cable Factor

Test Results: Worst Case Spurious from Antenna Positions 13 – 16.
15.209 Radiated Spurious Emissions Mid Channel, Tx at 2450.567868 MHz

Freq. (MHz)	Ant. Polarity	Raw Amp. @ 3m dBuV/m	Preamp dB	Ant. Factor dB/m	Cable Loss dB	Field Strength Final Amp @ 3m dBuV/m	Ant. Position	Ant Height m	Detector	Limit @3 m dBuV/m	Margin dB
5.986	Perp	48.92	32.02	35.60	0.24	52.74	14	1.00	Peak	69.50	-16.76
18.232	Par	40.36	32.02	34.79	0.32	43.44	15	1.00	Peak	69.50	-26.06
29.952	Par	50.23	32.01	24.48	0.40	43.10	16	1.00	Peak	69.50	-26.40
249.000	V	56.91	31.92	16.60	1.17	42.76	16	2.13	Peak	46.00	-3.24
327.000	H	55.66	31.93	18.40	1.34	43.47	16	1.72	Peak	46.00	-2.53
331.000	H	54.85	31.93	18.50	1.34	42.76	16	2.26	Peak	46.00	-3.24
400.000	V	47.81	31.97	20.30	1.50	37.64	15	2.74	Peak	46.00	-8.36
1721.800	V	64.60	45.30	25.35	3.06	47.70	15	1.33	Peak	54.00	-6.30
3681.100	H	60.24	44.12	30.86	4.56	51.53	16	2.27	Peak	54.00	-2.47
4901.136	V	54.46	43.71	32.83	5.31	48.90	13	2.99	Peak	74.00	-25.10
4901.136	V	38.10	43.71	32.83	5.31	32.54	13	2.99	Avg	54.00	-21.46
7351.704	H	50.75	43.95	37.48	6.59	50.87	14	1.00	Peak	74.00	-23.13
7351.704	H	36.99	43.95	37.48	6.59	37.11	14	1.00	Avg	54.00	-16.89
9802.272	H	51.26	44.23	38.09	7.63	52.76	16	1.00	Peak	74.00	-21.24
9802.272	H	36.73	44.23	38.09	7.63	38.22	16	1.00	Avg	54.00	-15.78
12252.840	H	50.28	44.58	38.29	8.68	52.67	16	1.00	Peak	74.00	-21.33
12252.840	H	36.84	44.58	38.29	8.68	39.23	16	1.00	Avg	54.00	-14.77
14703.408	H	50.89	46.08	40.17	9.63	54.62	16	1.00	Peak	74.00	-19.38
14703.408	H	35.07	46.08	40.17	9.63	38.80	16	1.00	Avg	54.00	-15.20
17153.976	H	50.88	44.08	41.26	10.46	58.52	16	1.00	Peak	74.00	-15.48
17153.976	H	35.90	44.08	41.26	10.46	43.54	16	1.00	Avg	54.00	-10.46

Note: Radiated emission measurements were performed up to 25GHz. No Emissions were identified when scanned from 18-25 GHz

Note: FS = Raw – Preamp Factor + Antenna Factor + Cable Factor

Test Results: Worst Case Spurious from Antenna Positions 1 – 4.
15.209 Radiated Spurious Emissions Mid Channel, Tx at 2463.921747 MHz

Freq. (MHz)	Ant. Polarity	Raw Amp. @ 3m dBuV/m	Preamp dB	Ant. Factor dB/m	Cable Loss dB	Field Strength Final Amp @ 3m dBuV/m	Ant. Position	Ant Height m	Detector	Limit @3 m dBuV/m	Margin dB
10.004	Par	45.48	32.02	35.10	0.20	48.76	1	1.00	Peak	69.50	-20.74
15.027	Perp	43.47	32.02	34.50	0.26	46.21	4	1.00	Peak	69.50	-23.29
18.130	Perp	43.93	32.02	34.79	0.32	47.02	2	1.00	Peak	69.50	-22.48
249.000	V	45.71	31.92	16.60	1.17	31.56	1	2.15	Peak	46.00	-14.44
327.000	H	51.24	31.93	18.40	1.34	39.05	1	1.59	Peak	46.00	-6.95
331.000	H	52.38	31.93	18.50	1.34	40.29	1	2.58	Peak	46.00	-5.71
400.000	V	49.48	31.97	20.30	1.50	39.31	1	1.42	Peak	46.00	-6.69
1721.800	V	65.11	45.30	25.35	3.06	48.21	1	1.36	Peak	54.00	-5.79
3681.100	H	58.54	44.12	30.86	4.56	49.83	1	2.47	Peak	54.00	-4.17
4927.844	V	54.71	43.70	32.87	5.33	49.20	1	2.15	Peak	74.00	-24.80
4927.844	V	38.95	43.70	32.87	5.33	33.44	1	2.15	Avg	54.00	-20.56
7391.766	H	50.11	43.97	37.44	6.61	50.20	1	1.00	Peak	74.00	-23.80
7391.766	H	36.81	43.97	37.44	6.61	36.89	1	1.00	Avg	54.00	-17.11
9855.688	H	51.50	44.23	38.14	7.65	53.06	1	1.00	Peak	74.00	-20.94
9855.688	H	36.23	44.23	38.14	7.65	37.79	1	1.00	Avg	54.00	-16.21
12319.610	H	51.25	44.64	38.38	8.70	53.69	1	1.00	Peak	74.00	-20.31
12319.610	H	35.66	44.64	38.38	8.70	38.10	1	1.00	Avg	54.00	-15.90
14783.532	H	51.37	46.00	39.90	9.66	54.93	1	1.00	Peak	74.00	-19.07
14783.532	H	35.07	46.00	39.90	9.66	38.63	1	1.00	Avg	54.00	-15.37
17247.454	H	50.52	44.05	41.57	10.47	58.51	1	1.00	Peak	74.00	-15.49
17247.454	H	36.63	44.05	41.57	10.47	44.61	1	1.00	Avg	54.00	-9.39

Note: Radiated emission measurements were performed up to 25GHz. No Emissions were identified when scanned from 18-25 GHz

Note: FS = Raw – Preamp Factor + Antenna Factor + Cable Factor

Test Results: Worst Case Spurious from Antenna Positions 5 – 8.
15.209 Radiated Spurious Emissions Mid Channel, Tx at 2463.921747 MHz

Freq. (MHz)	Ant. Polarity	Raw Amp. @ 3m dBuV/m	Preamp dB	Ant. Factor dB/m	Cable Loss dB	Field Strength Final Amp @ 3m dBuV/m	Ant. Position	Ant Height m	Detector	Limit @3 m dBuV/m	Margin dB
5.986	Perp	38.93	32.02	35.60	0.24	42.75	7	1.00	Peak	69.50	-26.75
11.726	Perp	30.38	32.02	34.65	0.20	33.22	6	1.00	Peak	69.50	-36.28
12.013	Par	42.70	32.02	34.60	0.21	45.48	6	1.00	Peak	69.50	-24.02
249.000	V	53.49	31.92	16.60	1.17	39.34	6	2.05	Peak	46.00	-6.66
327.000	H	55.54	31.93	18.40	1.34	43.35	7	2.18	Peak	46.00	-2.65
331.000	H	50.35	31.93	18.50	1.34	38.26	6	2.64	Peak	46.00	-7.74
400.000	V	46.92	31.97	20.30	1.50	36.75	7	1.56	Peak	46.00	-9.25
1721.800	V	61.52	45.30	25.35	3.06	44.62	6	2.34	Peak	54.00	-9.38
3681.100	H	59.89	44.12	30.86	4.56	51.18	6	1.12	Peak	54.00	-2.82
4927.844	V	52.78	43.70	32.87	5.33	47.27	6	2.90	Peak	74.00	-26.73
4927.844	V	37.40	43.70	32.87	5.33	31.89	6	2.90	Avg	54.00	-22.11
7391.766	H	50.72	43.97	37.44	6.61	50.80	5	1.53	Peak	74.00	-23.20
7391.766	H	36.48	43.97	37.44	6.61	36.56	5	1.53	Avg	54.00	-17.44
9855.688	H	50.28	44.23	38.14	7.65	51.84	5	1.00	Peak	74.00	-22.16
9855.688	H	35.94	44.23	38.14	7.65	37.50	5	1.00	Avg	54.00	-16.50
12319.610	H	51.26	44.64	38.38	8.70	53.70	5	1.00	Peak	74.00	-20.30
12319.610	H	35.72	44.64	38.38	8.70	38.16	5	1.00	Avg	54.00	-15.84
14783.532	H	51.82	46.00	39.90	9.66	55.37	5	1.00	Peak	74.00	-18.63
14783.532	H	36.50	46.00	39.90	9.66	40.06	5	1.00	Avg	54.00	-13.94
17247.454	H	50.05	44.05	41.57	10.47	58.03	5	1.00	Peak	74.00	-15.97
17247.454	H	36.25	44.05	41.57	10.47	44.24	5	1.00	Avg	54.00	-9.76

Note: Radiated emission measurements were performed up to 25GHz. No Emissions were identified when scanned from 18-25 GHz

Note: FS = Raw – Preamp Factor + Antenna Factor + Cable Factor

Test Results: Worst Case Spurious from Antenna Positions 9 – 12.
15.209 Radiated Spurious Emissions Mid Channel, Tx at 2463.921747 MHz

Freq. (MHz)	Ant. Polarity	Raw Amp. @ 3m dBuV/m	Preamp dB	Ant. Factor dB/m	Cable Loss dB	Field Strength Final Amp @ 3m dBuV/m	Ant. Position	Ant Height m	Detector	Limit @3 m dBuV/m	Margin dB
10.004	Par	49.32	32.02	35.10	0.20	52.60	10	1.00	Peak	69.50	-16.90
11.487	Perp	44.75	32.02	34.70	0.20	47.63	12	1.00	Peak	69.50	-21.87
13.544	Par	44.34	32.02	34.38	0.23	46.93	10	1.00	Peak	69.50	-22.57
249.000	V	55.03	31.92	16.60	1.17	40.88	11	2.00	Peak	46.00	-5.12
327.000	H	55.84	31.93	18.40	1.34	43.65	12	2.35	Peak	46.00	-2.35
331.000	H	53.97	31.93	18.50	1.34	41.88	12	1.58	Peak	46.00	-4.12
400.000	V	43.99	31.97	20.30	1.50	33.82	11	2.99	Peak	46.00	-12.18
1721.800	V	64.54	45.30	25.35	3.06	47.64	12	1.27	Peak	54.00	-6.36
3681.100	H	59.27	44.12	30.86	4.56	50.56	12	2.08	Peak	54.00	-3.44
4927.844	V	53.88	43.70	32.87	5.33	48.38	10	2.70	Peak	74.00	-25.62
4927.844	V	37.54	43.70	32.87	5.33	32.04	10	2.70	Avg	54.00	-21.96
7391.766	H	50.95	43.97	37.44	6.61	51.03	12	1.66	Peak	74.00	-22.97
7391.766	H	35.45	43.97	37.44	6.61	35.54	12	1.66	Avg	54.00	-18.46
9855.688	H	50.99	44.23	38.14	7.65	52.55	12	1.00	Peak	74.00	-21.45
9855.688	H	35.70	44.23	38.14	7.65	37.26	12	1.00	Avg	54.00	-16.74
12319.610	H	51.70	44.64	38.38	8.70	54.14	12	1.00	Peak	74.00	-19.86
12319.610	H	36.65	44.64	38.38	8.70	39.09	12	1.00	Avg	54.00	-14.91
14783.532	H	51.05	46.00	39.90	9.66	54.61	12	1.00	Peak	74.00	-19.39
14783.532	H	36.16	46.00	39.90	9.66	39.71	12	1.00	Avg	54.00	-14.29
17247.454	H	50.85	44.05	41.57	10.47	58.84	12	1.00	Peak	74.00	-15.16
17247.454	H	35.19	44.05	41.57	10.47	43.17	12	1.00	Avg	54.00	-10.83

Note: Radiated emission measurements were performed up to 25GHz. No Emissions were identified when scanned from 18-25 GHz

Note: FS = Raw – Preamp Factor + Antenna Factor + Cable Factor

Test Results: Worst Case Spurious from Antenna Positions 13 – 16.
15.209 Radiated Spurious Emissions Mid Channel, Tx at 2463.921747 MHz

Freq. (MHz)	Ant. Polarity	Raw Amp. @ 3m dBuV/m	Preamp dB	Ant. Factor dB/m	Cable Loss dB	Field Strength Final Amp @ 3m dBuV/m	Ant. Position	Ant Height m	Detector	Limit @3 m dBuV/m	Margin dB
5.986	Perp	47.74	32.02	35.60	0.24	51.56	14	1.00	Peak	69.50	-17.94
18.232	Par	42.02	32.02	34.79	0.32	45.10	15	1.00	Peak	69.50	-24.40
29.952	Par	48.76	32.01	24.48	0.40	41.63	16	1.00	Peak	69.50	-27.87
249.000	V	57.16	31.92	16.60	1.17	43.01	16	1.90	Peak	46.00	-2.99
327.000	H	55.67	31.93	18.40	1.34	43.48	16	2.14	Peak	46.00	-2.52
331.000	H	54.56	31.93	18.50	1.34	42.47	16	2.43	Peak	46.00	-3.53
400.000	V	47.64	31.97	20.30	1.50	37.47	15	1.14	Peak	46.00	-8.53
1721.800	V	65.60	45.30	25.35	3.06	48.70	15	1.52	Peak	54.00	-5.30
3681.100	H	60.49	44.12	30.86	4.56	51.78	16	1.86	Peak	54.00	-2.22
4927.844	V	54.09	43.70	32.87	5.33	48.58	13	2.67	Peak	74.00	-25.42
4927.844	V	37.57	43.70	32.87	5.33	32.06	13	2.67	Avg	54.00	-21.94
7391.766	H	51.13	43.97	37.44	6.61	51.22	14	1.41	Peak	74.00	-22.78
7391.766	H	36.80	43.97	37.44	6.61	36.89	14	1.41	Avg	54.00	-17.11
9855.688	H	50.95	44.23	38.14	7.65	52.51	16	1.00	Peak	74.00	-21.49
9855.688	H	35.44	44.23	38.14	7.65	37.00	16	1.00	Avg	54.00	-17.00
12319.610	H	50.93	44.64	38.38	8.70	53.37	16	1.00	Peak	74.00	-20.63
12319.610	H	35.58	44.64	38.38	8.70	38.02	16	1.00	Avg	54.00	-15.98
14783.532	H	51.37	46.00	39.90	9.66	54.93	16	1.00	Peak	74.00	-19.07
14783.532	H	36.10	46.00	39.90	9.66	39.66	16	1.00	Avg	54.00	-14.34
17247.454	H	50.95	44.05	41.57	10.47	58.94	16	1.00	Peak	74.00	-15.06
17247.454	H	35.60	44.05	41.57	10.47	43.59	16	1.00	Avg	54.00	-10.41

Note: Radiated emission measurements were performed up to 25GHz. No Emissions were identified when scanned from 18-25 GHz

Note: FS = Raw – Preamp Factor + Antenna Factor + Cable Factor

4.7.7 Test Setup Photographs

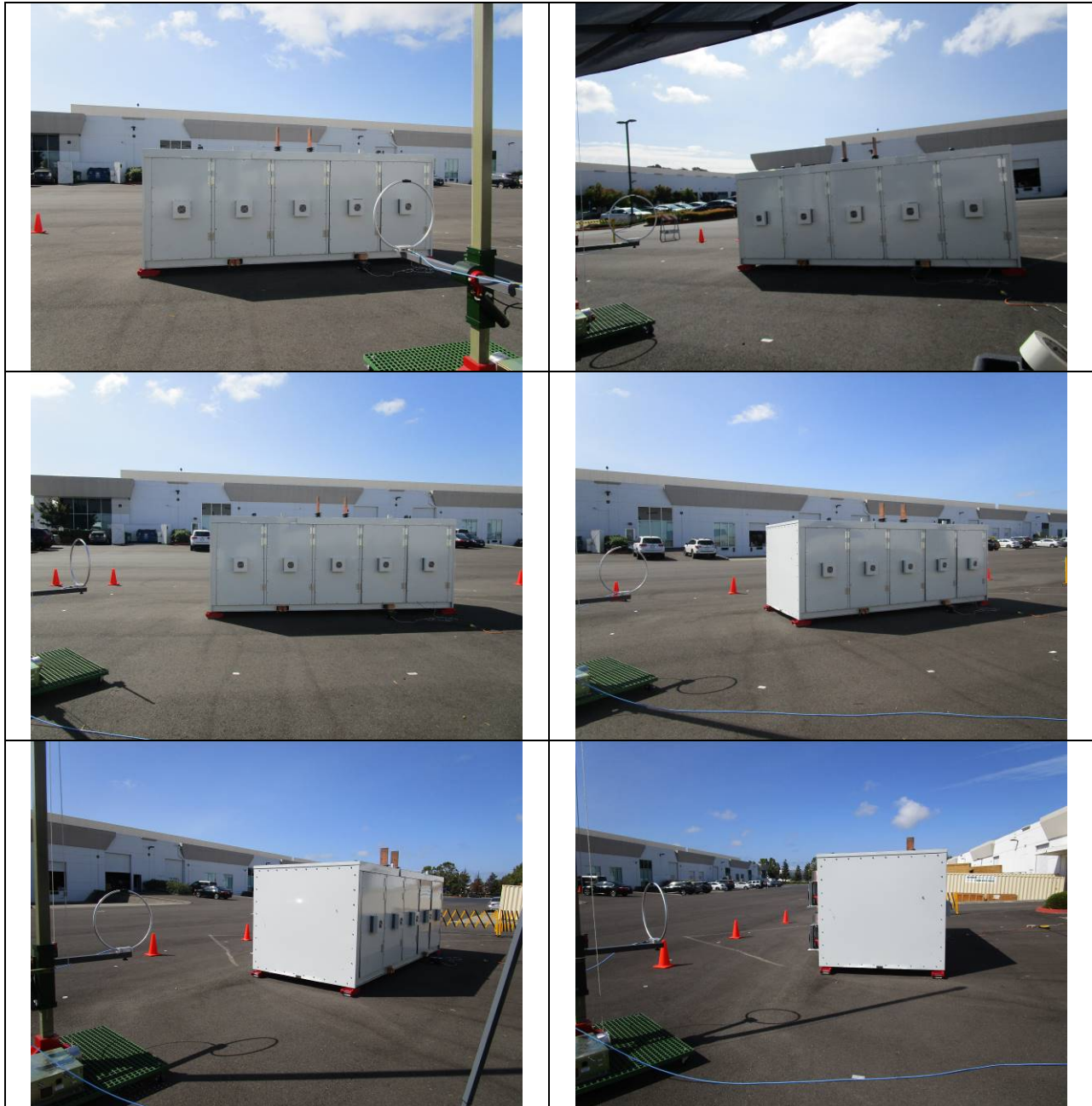





4.7.5 Test Setup Photographs (Continued)







The following photographs show the testing configurations used.



4.7.5 Test Setup Photographs (Continued)



4.7.5 Test Setup Photographs (Continued)



4.8 AC Line Conducted Emission
FCC: 15.207

4.8.1 Requirement

Frequency Band MHz	Class B Limit dB(μ V)		Class A Limit dB(μ V)	
	Quasi-Peak	Average	Quasi-Peak	Average
0.15-0.50	66 to 56 *	56 to 46 *	79	66
0.50-5.00	56	46	73	60
5.00-30.00	60	50	73	60

Note: *Decreases linearly with the logarithm of the frequency
At the transition frequency the lower limit applies.

4.8.2 Procedure

Measurements are carried out using quasi-peak and average detector receivers in accordance with CISPR 16. An AMN is required to provide a defined impedance at high frequencies across the power feed at the point of measurement of terminal voltage and also to provide isolation of the circuit under test from the ambient noise on the power lines. An AMN as defined in CISPR 16 shall be used.

The EUT is located so that the distance between the boundary of the EUT and the closest surface of the AMN is 0.8m.

Where a flexible mains cord is provided by the manufacturer, this shall be 1m long or if in excess of 1m, the excess cable is folded back and forth as far as possible so as to form a bundle not exceeding 0.4m in length.

The EUT is arranged and connected with cables terminated in accordance with the product specification.

Conducted disturbance is measured between the phase lead and the reference ground, and between the neutral lead and the reference ground. Both measured values are reported.

The EUT, where intended for tabletop use, is placed on a table whose top is 0.8m above the ground plane. A vertical, metal reference plane is placed 0.4m from the EUT. The vertical metal reference-plane is at least 2m by 2m. The EUT shall be kept at least 0.8m from any other metal surface or other ground plane not being part of the EUT. The table is constructed of non-conductive materials. Its dimensions are 1m by 1.5m, but may be extended for larger EUT.

Floor standing EUT are placed on a horizontal metal ground plane and isolated from the ground plane by resting on an insulating material. The metal ground plane extends at least 0.5m beyond the boundaries of the EUT and has minimum dimensions of 2m by 2m.

Equipment setup for conducted disturbance tests followed the guidelines of ANSI C63.4:2014 and ANSI C63.10:2013.

4.8.3 Test Results

Tested By	Test Date
Ollie Moyrong	September 11, 2020

Conducted Emissions 120VAC 60Hz, FCC Part 15.207

Phase 1

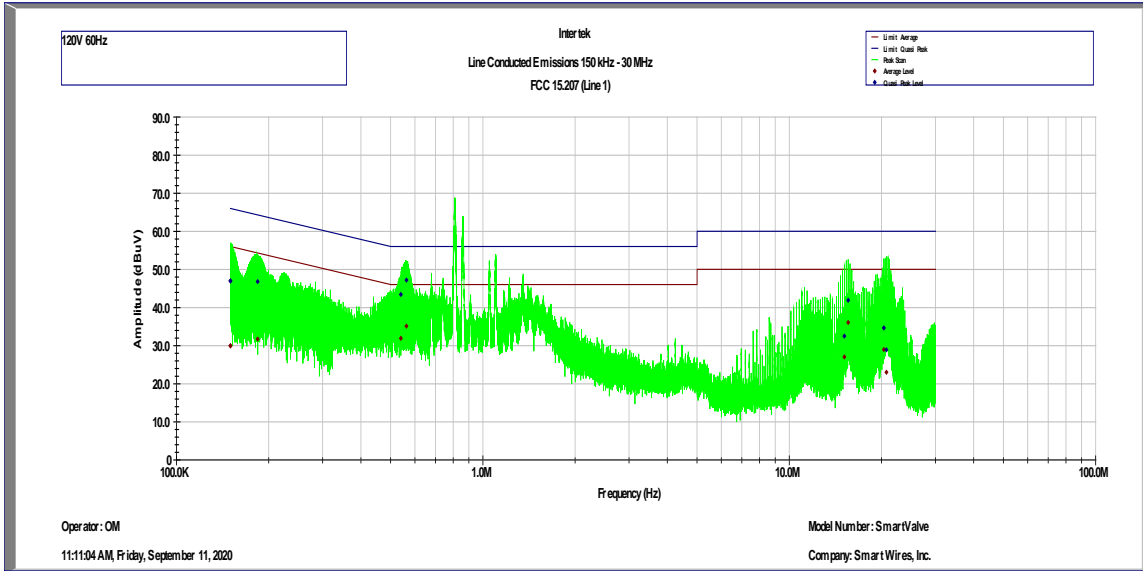

Frequency	Av Level	QP Level	Av Limit	QP Limit	Av Margin	QP Margin
MHz	dBuV	dBuV	dBuV	dBuV	dB	dB
0.150	29.90	47.00	56.00	66.00	-26.10	-19.00
0.184	31.70	46.80	55.00	65.00	-23.30	-18.20
0.540	31.90	43.40	46.00	56.00	-14.10	-12.60
0.563	35.10	47.20	46.00	56.00	-10.90	-8.80
15.116	27.00	32.50	50.00	60.00	-23.00	-27.50
15.560	36.10	41.90	50.00	60.00	-13.90	-18.10
20.340	29.00	34.60	50.00	60.00	-21.00	-25.40
20.740	23.00	28.90	50.00	60.00	-27.00	-31.10

Note: Spurious were investigated at 810 kHz, 860 kHz, 1.05 MHz, 1.10 MHz, 1.22 MHz & 1.305 MHz. These Spurious were confirmed to be the local AM Radio Stations.

Conducted Emissions 120VAC 60Hz, FCC Part 15.207

Phase 2

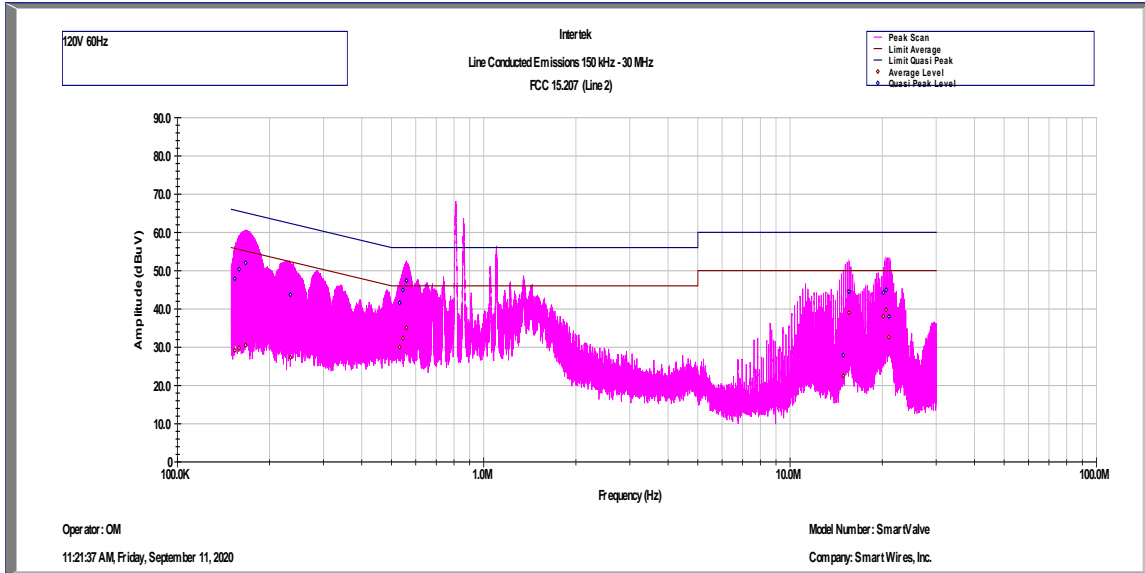

Frequency	Av Level	QP Level	Av Limit	QP Limit	Av Margin	QP Margin
MHz	dBuV	dBuV	dBuV	dBuV	dB	dB
0.154	29.10	47.90	55.90	65.90	-26.80	-18.00
0.159	29.80	50.40	55.70	65.70	-26.00	-15.40
0.167	30.50	52.00	55.50	65.50	-25.00	-13.50
0.234	27.30	43.70	53.60	63.60	-26.30	-19.90
0.532	30.00	41.60	46.00	56.00	-16.00	-14.40
0.545	32.30	44.90	46.00	56.00	-13.70	-11.10
0.559	35.00	47.40	46.00	56.00	-11.00	-8.60
14.900	22.50	27.90	50.00	60.00	-27.50	-32.10
15.570	39.00	44.50	50.00	60.00	-11.00	-15.50
20.145	38.00	44.30	50.00	60.00	-12.00	-15.70
20.580	39.70	45.00	50.00	60.00	-10.30	-15.00
21.010	32.60	38.00	50.00	60.00	-17.40	-22.00

Note: Spurious were investigated at 810 kHz, 860 kHz, 1.05 MHz, 1.10 MHz, 1.22 MHz & 1.305 MHz. These Spurious were confirmed to be the local AM Radio Stations.

Results: Complies by 8.60 dB

4.8.4 Test Configuration Photographs



5.0 List of Test Equipment and Software

Measurement equipment used for emission compliance testing utilized the equipment on the following list:

Test Date: November 18 – December 10, 2019

Equipment Description	Manufacturer	Model/ Type	Asset No.	Monthly Cal Interval	Cal Due
EMI Receiver	Rohde and Schwarz	ESR	ITS 01607	12	10/23/20
EMI Receiver	Rohde and Schwarz	ESU40	ITS 00961	12	11/07/20
Spectrum Analyzer	Rohde and Schwarz	FSU	ITS 00913	12	03/26/20
Active Horn Antenna	ETS-Lindgren	3117-PA	ITS 01636	12	01/17/20
BI-Log Antenna	Antenna Research	LPB-2513	ITS 00355	12	04/24/20
Pre-Amplifier	Sonoma Instrument	310N	ITS 00415	12	04/104/20
Horn Antenna (10-40 GHz)	ETS-Lindgren	3116C	ITS 01376	12	02/15/20
Pre-Amplifier (18-40GHz)	Miteq	TTA1840-35-S-M	ITS 01393	12	02/08/20
LISN	FCC	FCC-LISN-PA-NEMA-5-15	ITS 00551	12	11/13/20
RF Cable	Megaphase	TM40-K1K1-59	ITS 01657	12	11/11/20
RF Cable	Megaphase	EMC1-K1K1-236	ITS 01537	12	02/20/20
RF Cable	TRU Corporation	TRU CORE 300	ITS 01330	12	05/09/20
RE Cable	TRU Corporation	TRU CORE 300	ITS 01465	12	08/27/20
RE Cable	TRU Corporation	TRU CORE 300	ITS 01470	12	08/27/20
Transient Limiter	COM-POWER	LIT-153A	ITS 01452	12	08/30/20
Notch Filter	Micro-Tronics	BRC50722	ITS 01170	12	03/18/20
High Pass Filter	Micro-Tronics	HPM50144-02	ITS 01722	12	11/11/20
Attenuator	Mini Circuits	FSCM99899	ITS 01582	12	10/07/20

Test Date: September 11 to October 14, 2020

Equipment Description	Manufacturer	Model/ Type	Asset No.	Cal Interval	Cal Due
EMI Receiver	Rohde and Schwarz	ESR	ITS 01607	12	10/23/20
EMI Receiver	Rohde and Schwarz	ESU40	ITS 00961	12	11/07/20
Spectrum Analyzer	Rohde and Schwarz	FSU	ITS 00913	12	01/04/21
Horn Antenna	ETS-Lindgren	3115	ITS 00982	12	04/21/21
Bi-Log Antenna	Teseq	CBL 6111D	ITS 01058	12	10/29/20
Loop Antenna	EMCO	6512	ITS 01598	12	10/22/20
Pre-Amplifier (30 – 1000 MHz)	Sonoma Instrument	310N	ITS 00415	12	04/27/21
1-18GHz Preamplifier	uComp Nordic	MCN-40-001018002510P	ITS 01817	12	04/16/21
Pyramidal Horn Antenna	EMCO	3160-09	ITS 00571	#	#
Pre-Amplifier (18-40GHz)	Miteq	TTA1840-35-S-M	ITS 01393	12	03/02/21
LISN	COM-POWER	LIM-N-115A	ITS 01283	12	11/12/20
RF Cable	Megaphase	TM40-K1K1-59	ITS 01657	12	11/11/20
RF Cable	Megaphase	EMC1-K1K1-236	ITS 01484	12	06/12/21
RF Cable	TRU Corporation	TRU CORE 300	ITS 01618	12	04/13/21
Notch Filter	Micro-Tronics	BRM50702	ITS 01166	12	06/11/21
Notch Filter	Micro-Tronics	RBRC50722	ITS 01170	12	04/17/21
Notch Filter	Micro-Tronics	HPM50114-02	ITS 01722	12	11/11/20
Attenuator	Mini Circuits	FSCM99899	ITS 01582	12	10/07/20

No Calibration required

Software used for emission compliance testing utilized the following:

Name	Manufacturer	Version	Template/Profile
Tile	Quantum Change	3.4.K.22	Conducted Spurious_30M-26GHz Conducted Emissions
RS Commander	Rohde Schwarz	1.6.4	Not Applicable (Screen grabber)

6.0 Document History

Revision/ Job Number	Writer Initials	Reviewers Initials	Date	Change
1.0 / G104368457	AS	KV	November 3, 2020	Original Document

END OF REPORT