



# TEST REPORT

No. I17D00122-EMC01

*For*

**Client : Mobewire SAS**

**Production: 4G Smartphone**

**Model Name : MobiWire Waneta+, ALTICE S70**

**Hardware Version: V01**

**Software Version: WE552\_ALTICE\_S70**

**FCC ID: QPN-WANETAPLUS**

**Issued date: 2017-08-01**

**Note:**

The test results in this test report relate only to the devices specified in this report. This report shall not be reproduced except in full without the written approval of ECIT Shanghai.

**Test Laboratory:**

ECIT Shanghai, East China Institute of Telecommunications

Add: 7F, G Area, No.668, Beijing East Road, Huangpu District, Shanghai, P. R. China

Tel: (+86)-021-63843300, E-Mail: [welcome@ecit.org.cn](mailto:welcome@ecit.org.cn)

### Revision Version

Report Number	Revision	Date	Memo
I17D00122-EMC01	00	2017-08-01	Initial creation of test report

## CONTENTS

<b>1. TEST LABORATORY .....</b>	<b>5</b>
<b>1.1. TESTING LOCATION .....</b>	<b>5</b>
<b>1.2. TESTING ENVIRONMENT .....</b>	<b>5</b>
<b>1.3. PROJECT DATA .....</b>	<b>5</b>
<b>1.4. SIGNATURE .....</b>	<b>5</b>
<b>2. CLIENT INFORMATION .....</b>	<b>6</b>
<b>2.1. APPLICANT INFORMATION .....</b>	<b>6</b>
<b>2.2. MANUFACTURER INFORMATION .....</b>	<b>6</b>
<b>3. EQUIPMENT UNDER TEST (EUT) AND ANCILLARY EQUIPMENT (AE) .....</b>	<b>7</b>
<b>3.1. ABOUT EUT .....</b>	<b>7</b>
<b>3.2. INTERNAL IDENTIFICATION OF EUT USED DURING THE TEST .....</b>	<b>7</b>
<b>3.3. INTERNAL IDENTIFICATION OF AE USED DURING THE TEST .....</b>	<b>7</b>
<b>4. REFERENCE DOCUMENTS.....</b>	<b>8</b>
<b>4.3. REFERENCE DOCUMENTS FOR TESTING .....</b>	<b>8</b>
<b>5. TEST RESULTS.....</b>	<b>9</b>
<b>5.3. SUMMARY OF TEST RESULTS.....</b>	<b>9</b>
<b>5.4. STATEMENTS.....</b>	<b>9</b>
<b>6. TEST EQUIPMENT UTILIZED .....</b>	<b>10</b>
<b>6.1 RADIATED EMISSION EQUIPMENT LIST .....</b>	<b>10</b>
<b>6.1 CE EQUIPMENT LIST .....</b>	<b>10</b>
<b>7. SYSTEM CONFIGURATION DURING TEST .....</b>	<b>11</b>
<b>7.1 TEST MODE.....</b>	<b>11</b>
<b>7.2 CONNECTION DIAGRAM OF TEST SYSTEM.....</b>	<b>11</b>
<b>8. MEASUREMENT RESULTS .....</b>	<b>12</b>
<b>8.1 RADIATED EMISSION 30MHZ-12.75GHZ .....</b>	<b>12</b>

**8.2 CONDUCTED EMISSION..... 16**

## 1. Test Laboratory

### 1.1. Testing Location

Company Name: ECIT Shanghai, East China Institute of Telecommunications  
Address: 7F, G Area, No. 668, Beijing East Road, Huangpu District, Shanghai,  
P. R. China  
Postal Code: 200001  
Telephone: 86-21-63843300  
Fax: 86-21-63843301  
FCC registration No: 489729

### 1.2. Testing Environment

Normal Temperature: 15-35°C  
Relative Humidity: 30-60%

### 1.3. Project data

Project Leader: Yu Anlu  
Testing Start Date: 07-17,2017  
Testing End Date: 07-27, 2017

### 1.4. Signature

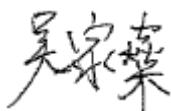

Wu Jiashen

(Prepared this test report)



You Jinjun

(Reviewed this test report)

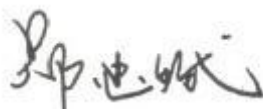

Zheng Zhongbin

Director of the laboratory

(Approved this test report)

## 2. Client Information

### 2.1. Applicant Information

Company Name:           Mobiwire SAS  
Address :                 79 AVENUE FRANCOIS ARAGO 92017 NANTERRE CEDEX  
                              France.  
Telephone:               +33 178 14 09 33  
Postcode:                /

### 2.2. Manufacturer Information

Company Name:           Mobiwire SAS  
Address /Post:           79 AVENUE FRANCOIS ARAGO 92017 NANTERRE CEDEX  
                              France.  
Telephone:               +33 178 14 09 33  
Postcode:                /

### 3. Equipment under Test (EUT) and Ancillary Equipment (AE)

#### 3.1. About EUT

EUT Description	4G Smartphone
Model name	MobiWire Waneta+, ALTICE S70
Serial Number or IMEI	357581080005448
HW Version	V01
SW Version	WE552_ALTICE_S70
Additional Communication Function	BT2.1,EDR,3.0,4.0,BLE;WIFI 802.11a,b,g,n(HT20/HT40) , WIFI Band: 5150MHz-5250MHz,5250 MHz-5350 MHz, 5745 MHz-5825 MHz; GPS;FM;NFC

#### 3.2. Internal Identification of EUT used during the test

EUT ID*	SN or IMEI	HW Version	SW Version	Date of receipt
N42	357581080005448	V01	WE552_ALTICE_S70	2017-07-13

\*EUT ID: is used to identify the test sample in the lab internally.

#### 3.3. Internal Identification of AE used during the test

AE ID*	Description	Model	SN
CA02	Adapter	A88-502000	/
UA23	Data Cable	JWBU1344-M01	/
AE1	Desktop PC	OptiPlex 790 DT	X8RP1 A01 APCC
AE2	Notebook PC	DELL Latitude E5250	/
AE3	LAN Cable	NA	NA
AE4	VGA Cable	NA	NA
AE5	RS232 Cable	NA	NA
AE6	Keyboard	KB212-B	CN-0Y88XT-65890-12I-005Q-A00
AE7	Mouse	MS111-P	CN-011D3V-71581-19J-1A64
AE8	Micro SD Card	Kingston SDC4/4GB 77	/

\*AE ID: is used to identify the test sample in the lab internally.

## 4. Reference Documents

### 4.3. Reference Documents for testing

The following documents listed in this section are referred for testing.

Reference	Title	Version
FCC Part 15, Subpart B	Radio frequency devices	10-1-10 Edition
ANSI C63.4	Method of Measurement of Radio-Noise Emissions from Low-Voltage Electrical and Electronic Equipment in the Range of 9 kHz to 40 GHz	2014



## 5. Test Results

### 5.3. Summary of Test Results

Items	Test List	Clause in FCC rules	Verdict
1	Radiated Emission	15.109(a)	Pass
2	Conducted Emission	15.107(a)	Pass

### 5.4. Statements

TheMobiWire Waneta+, ALTICE S70, manufactured by Mobewire SAS is a new product for testing. ECIT performed test cases which identified with Pass/Fail/Inc result in section 5.1.

ECIT has verified that the compliance of the tested device specified in section 3 of this test report is successfully evaluated according to the procedure and test methods as defined in type certification requirement listed in section 4 of this test report.

## 6. Test Equipment Utilized

### 6.1 Radiated Emission Equipment list

No.	Name	Type	Series Number	Producer	Cal. Date	Cal. interval
1	Universal Radio Communication	CMU200	123126	R&S	2017-05-11	1 Year
2	Test Receiver	ESU40	100307	R&S	2017-05-11	1 Year
3	Trilog Antenna	VULB9163	VULB9163-515	Schwarzbeck	2017-02-25	3 Year
4	Double Ridged Guide	ETS-3117	00135885	ETS	2017-01-11	3 Year
5	EMI Test Software	EMC32 V9.15	NA	R&S	NA	NA

### 6.1 CE Equipment list

No.	Name	Type	Series Number	Producer	Cal. Date	Cal. interval
1	Universal Radio	CMU200	123123	R&S	2017-05-11	1 Year
2	Test Receiver	ESCI	101235	R&S	2017-05-11	1 Year
3	2-Line V-Network	ENV216	101380	R&S	2017-05-11	1 Year
4	EMI Test Software	EMC32 V9.15	NA	R&S	NA	NA

## 7. System Configuration during Test

### 7.1 Test Mode

Test Item	Function Type
AC Conducted Emission	Mode 1: USB cable (Data Link with PC) <Figure 1> Mode 2: Idle+ Adapter charging <Figure 2>
Radiated Emission	Mode 1: USB cable (Data Link with PC) <Figure 1> Mode 2: Idle+ Adapter charging <Figure 2>
Remark: 1. All test modes are performed, only the worst cases test data are recorded in this report. 2. Data Link with PC means data application transferred mode between EUT and PC.	

### 7.2 Connection Diagram of Test System

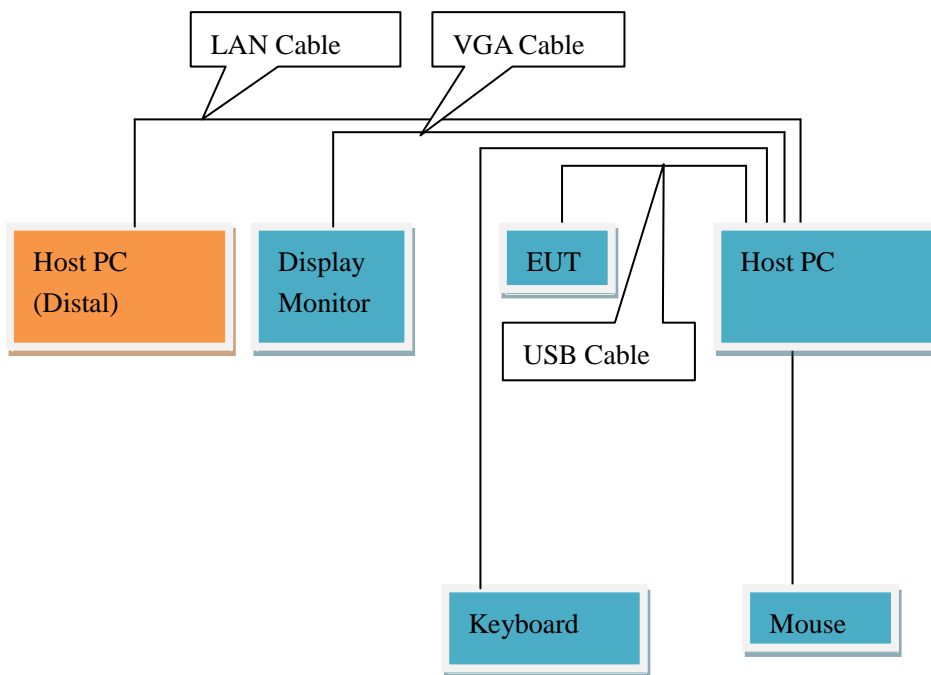

<Figure 1>



<Figure 2>

## 8. Measurement Results

Only the worst test result was shown in this report.

### 8.1 Radiated Emission 30MHz-12.75GHz

#### Method of Measurement

For 30-1000MHz, the EUT was placed on the top of a rotating 0.8-m table above the ground at a semi-anechoic chamber. The distance between the EUT and the received antenna was 3 meters. The table was rotated 360 degree and the received antenna mounted on a variable-height antenna tower was varied from 1m to 4m to find the maximum value of the field strength. Both horizontal and vertical polarizations of the antenna were set during the measurement. Tested in accordance with the procedures of ANSI C63.4-2014, section 8.3.

For 1000-12750MHz, The maximal emission value was acquired by adjusting the antenna height, The table was rotated 360 degree to determine the maximum value of the field strength. Both horizontal and vertical polarizations of the antenna were set during the measurement.

#### Limits for Radiated Emission at a measuring distance of 3m

Frequency Range (MHz)	Quasi-Peak (dBuV/m)
30-88	40
88-216	43.5
216-960	46
Above 960	54

Frequency Range (MHz)	Peak (dBuV/m)	Average (dBuV/m)
Above 1000	74	54

#### Test conditions

Frequency Range (MHz)	RBW/VBW	Sweep Time (s)
30-1000	120KHz/300KHz	Auto
1000-12750	1MHz/3MHz	Auto

#### Uncertainty Measurement

The measurement uncertainty is 5.82dB (k=2).

## Test Results

Mode 1: USB cable (Data Link with PC)

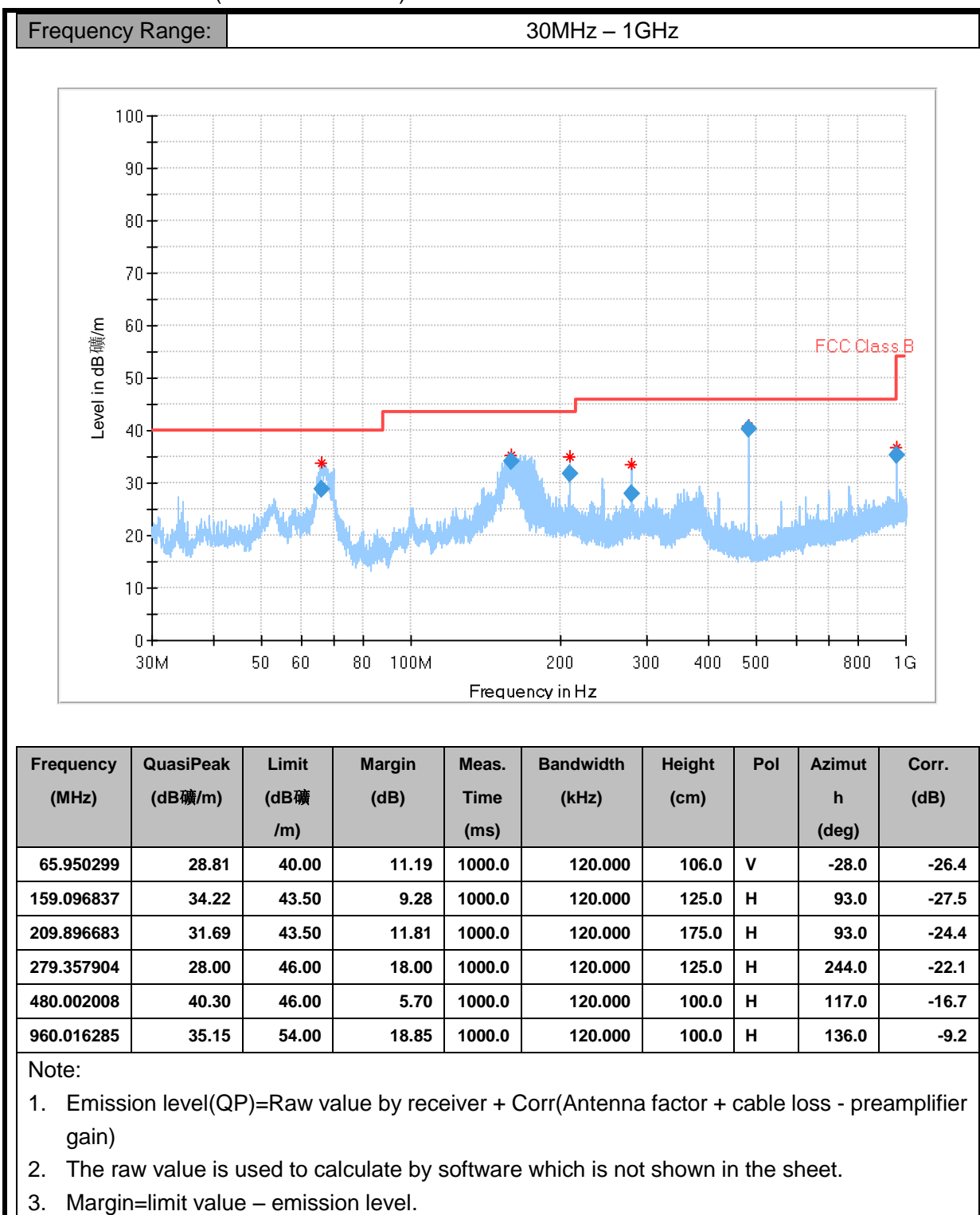

Mode 2: Idle+Adapter charging

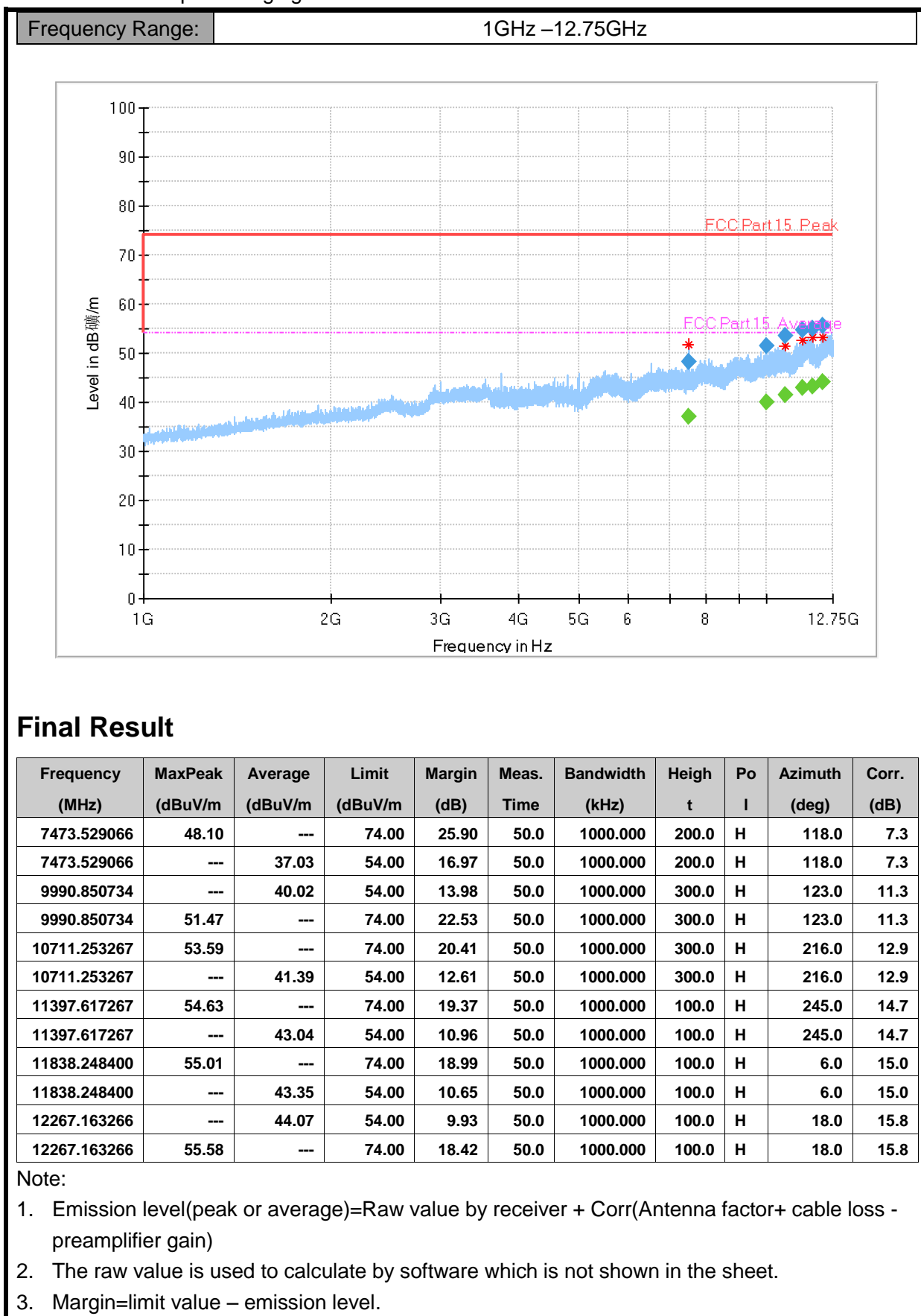

## Final Result

Frequency (MHz)	MaxPeak (dBuV/m)	Average (dBuV/m)	Limit (dBuV/m)	Margin (dB)	Meas. Time	Bandwidth (kHz)	Height	Po	Azimuth (deg)	Corr. (dB)
7473.529066	48.10	---	74.00	25.90	50.0	1000.000	200.0	H	118.0	7.3
7473.529066	---	37.03	54.00	16.97	50.0	1000.000	200.0	H	118.0	7.3
9990.850734	---	40.02	54.00	13.98	50.0	1000.000	300.0	H	123.0	11.3
9990.850734	51.47	---	74.00	22.53	50.0	1000.000	300.0	H	123.0	11.3
10711.253267	53.59	---	74.00	20.41	50.0	1000.000	300.0	H	216.0	12.9
10711.253267	---	41.39	54.00	12.61	50.0	1000.000	300.0	H	216.0	12.9
11397.617267	54.63	---	74.00	19.37	50.0	1000.000	100.0	H	245.0	14.7
11397.617267	---	43.04	54.00	10.96	50.0	1000.000	100.0	H	245.0	14.7
11838.248400	55.01	---	74.00	18.99	50.0	1000.000	100.0	H	6.0	15.0
11838.248400	---	43.35	54.00	10.65	50.0	1000.000	100.0	H	6.0	15.0
12267.163266	---	44.07	54.00	9.93	50.0	1000.000	100.0	H	18.0	15.8
12267.163266	55.58	---	74.00	18.42	50.0	1000.000	100.0	H	18.0	15.8

Note:

1. Emission level(peak or average)=Raw value by receiver + Corr(Antenna factor+ cable loss - preamplifier gain)
2. The raw value is used to calculate by software which is not shown in the sheet.
3. Margin=limit value – emission level.

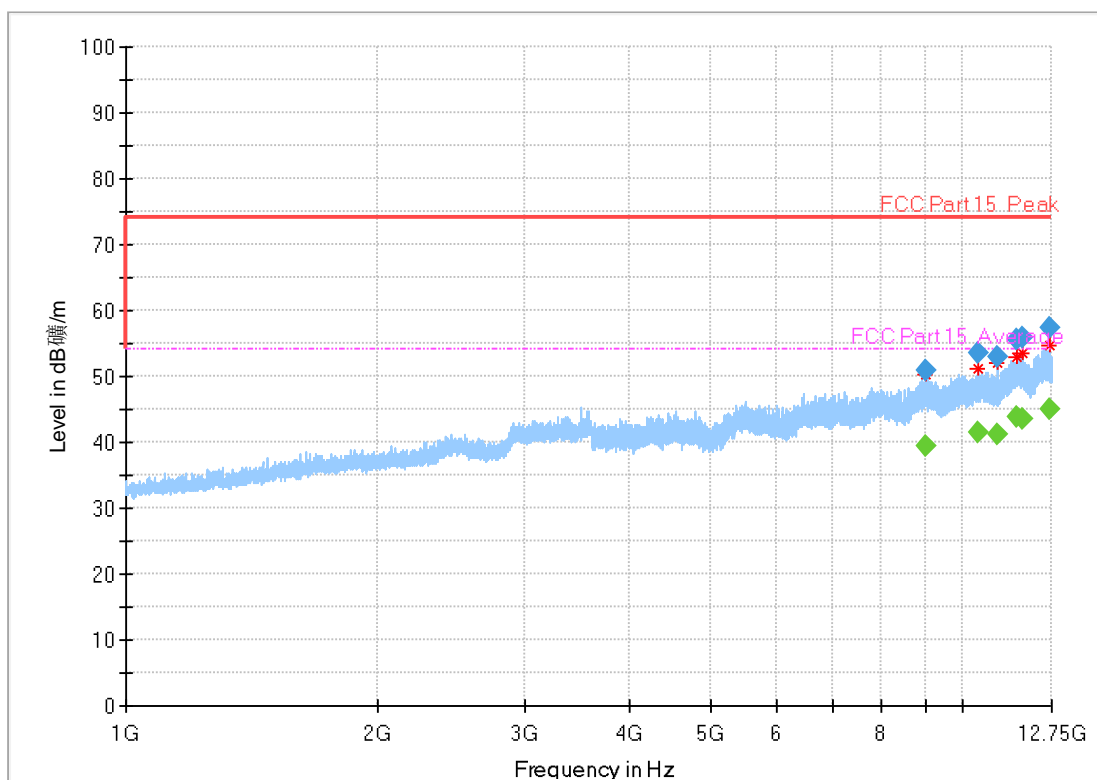

## Final Result

Frequency (MHz)	MaxPeak (dBuV/m)	Average (dBuV/m)	Limit (dBuV/m)	Margin	Meas. Time	Bandwidth (h)	Height (t)	Polarization (l)	Azimuth (deg)	Corr. (dB)
9004.216533	50.91	---	74.00	23.09	50.0	1000.000	300.0	V	135.0	10.3
9004.216533	---	39.27	54.00	14.73	50.0	1000.000	300.0	V	135.0	10.3
10417.074134	53.45	---	74.00	20.55	50.0	1000.000	100.0	V	177.0	12.8
10417.074134	---	41.48	54.00	12.52	50.0	1000.000	100.0	V	177.0	12.8
10991.387800	---	41.05	54.00	12.95	50.0	1000.000	300.0	V	339.0	12.8
10991.387800	52.88	---	74.00	21.12	50.0	1000.000	300.0	V	339.0	12.8
11564.598867	---	43.69	54.00	10.31	50.0	1000.000	300.0	V	22.0	15.2
11564.598867	55.47	---	74.00	18.53	50.0	1000.000	300.0	V	22.0	15.2
11796.154800	---	43.56	54.00	10.44	50.0	1000.000	100.0	V	325.0	15.2
11796.154800	55.78	---	74.00	18.22	50.0	1000.000	100.0	V	325.0	15.2
12655.039200	---	44.98	54.00	9.02	50.0	1000.000	200.0	V	96.0	16.8
12655.039200	57.40	---	74.00	16.60	50.0	1000.000	200.0	V	96.0	16.8

Note:

1. Emission level(peak or average)=Raw value by receiver + Corr(Antenna factor+ cable loss - preamplifier gain)
2. The raw value is used to calculate by software which is not shown in the sheet.
3. Margin=limit value – emission level.

## 8.2 Conducted Emission

### Method of Measurement

For equipment that is designed to be connected to the public utility (AC) power line, the radio frequency voltage that is conducted back onto the AC power line on any frequency or frequencies with the band 150 kHz to 30MHz shall not exceed the limits. Both lines of the power mains connected to the EUT were checked for maximum conducted interference. Tested in accordance with the procedures of ANSI C63.4-2014, section 7.3

### Limit of Conducted Emission

Frequency Range (MHz)	Conducted Limit (dBuV)	
	Quasi-peak	Average
0.15-0.5	66 to 56*	56 to 46*
0.5-5	56	46
5-30	60	50

\*Decreases with the logarithm of the frequency

### Test Condition in Charging Mode

Voltage (V)	Frequency (Hz)	RBW	Sweep Time (s)
120	60	9 KHz	Auto

### Uncertainty Measurement

The measurement uncertainty is 3.47dB (k=2).

### Test Results

Mode 1: USB cable (Data Link with PC)



Frequency Range:

150kHz – 30MHz

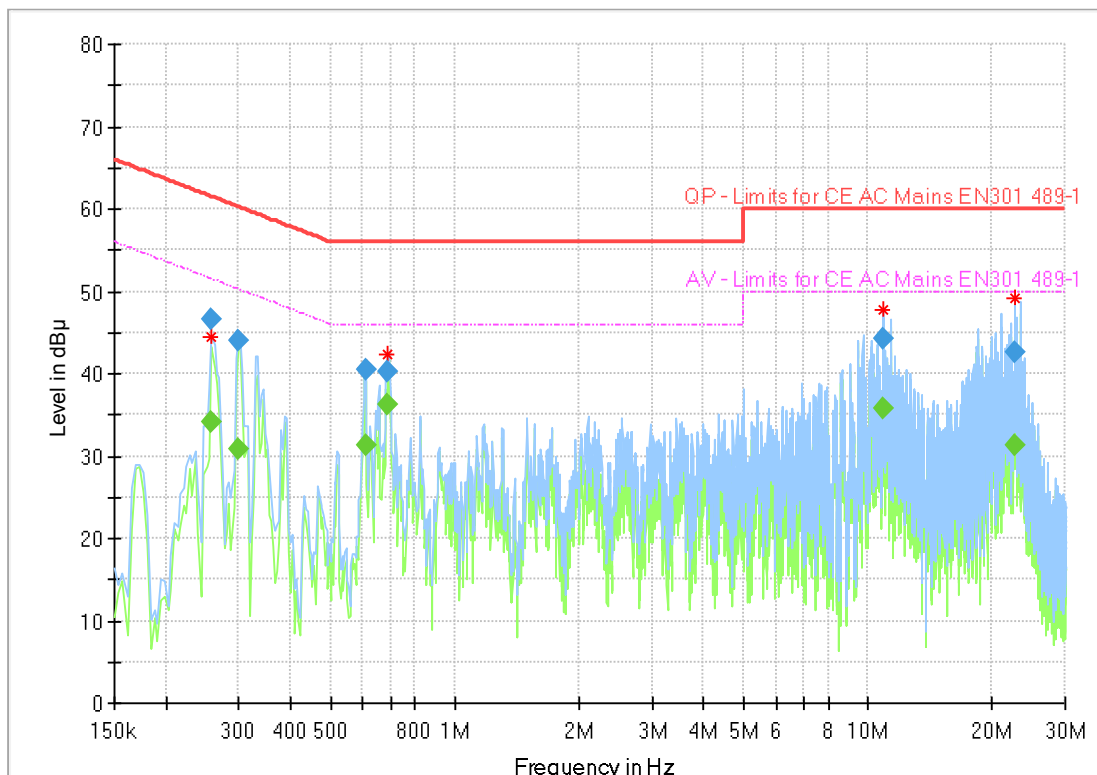

Frequency (MHz)	QuasiPeak (dBµ V)	Average (dBµ V)	Limit (dBµ V)	Margin (dB)	Meas. Time	Bandwidth (kHz)	Line	Filter	Corr. (dB)
0.258206	46.52	---	61.49	14.97	1000.0	9.000	N	ON	9.7
0.258206	---	34.09	51.49	17.40	1000.0	9.000	N	ON	9.7
0.299250	43.89	---	60.26	16.37	1000.0	9.000	N	ON	9.7
0.299250	---	30.87	50.26	19.39	1000.0	9.000	N	ON	9.7
0.608944	---	31.32	46.00	14.68	1000.0	9.000	N	ON	9.7
0.608944	40.37	---	56.00	15.63	1000.0	9.000	N	ON	9.7
0.687300	---	36.13	46.00	9.87	1000.0	9.000	L1	ON	9.7
0.687300	40.25	---	56.00	15.75	1000.0	9.000	L1	ON	9.7
10.910925	---	35.74	50.00	14.26	1000.0	9.000	L1	ON	9.8
10.910925	44.34	---	60.00	15.66	1000.0	9.000	L1	ON	9.8
22.578544	---	31.32	50.00	18.68	1000.0	9.000	N	ON	10.0
22.578544	42.53	---	60.00	17.47	1000.0	9.000	N	ON	10.0

Note:

1. Emission level(quasi-peak or Average peak)=Raw value by receiver + Corr(Insertion loss+cable loss)
2. The raw value is used to calculate by software which is not shown in the sheet.
3. Margin=limit value – emission level.
4. L1 and N line is all have been tested, the result of them is synthesized in the above data diagram.

\*\*\*\*\*End of Report\*\*\*\*\*