



RF TEST REPORT

Applicant Mobiwire SAS
FCC ID QPN-WANETA
Product 4G Smartphone
Brand MobiWire, ALTICE
Model MobiWire Waneta, ALTICE S60
Report No. RXA1707-0221RF03
Issue Date July 27, 2017

TA Technology (Shanghai) Co., Ltd. tested the above equipment in accordance with the requirements in **FCC CFR47 Part 15C (2017)**. The test results show that the equipment tested is capable of demonstrating compliance with the requirements as documented in this report.

Performed by: Xianqing Li

Reviewed by: Kai Xu

TA Technology (Shanghai) Co., Ltd.

No.145, Jintang Rd, Tangzhen Industry Park, Pudong Shanghai, China

TEL: +86-021-50791141/2/3

FAX: +86-021-50791141/2/3-8000



TABLE OF CONTENT

- 1. Test Laboratory 4
 - 1.1. Notes of the test report..... 4
 - 1.2. Test facility 4
 - 1.3. Testing Location..... 5
- 2. General Description of Equipment under Test..... 6
- 3. Applied Standards 7
- 4. Test Configuration 8
- 5. Test Case Results 9
 - 5.1. 20dB Bandwidth 9
 - 5.2. Frequency Stability..... 11
 - 5.3. Radiates Emission 14
 - 5.4. Conducted Emission 21
- 6. Main Test Instruments 24
- ANNEX A: EUT Appearance and Test Setup 25
 - A.1 EUT Appearance 25
 - A.2 Test Setup 26



Summary of measurement results

Number	Summary of measurements of results	Clause in FCC rules	Verdict
1	20 dB bandwidth	2.1049	PASS
2	Frequency Stability Tolerance	15.225(e)	PASS
3	Radiated Emissions	15.225 (a) (b) (c) (d) and 15.209	PASS
4	Conducted Emissions	15.207	PASS

Date of Testing: July 13, 2017 ~July 24, 2017



1. Test Laboratory

1.1. Notes of the test report

This report shall not be reproduced in full or partial, without the written approval of **TA technology (shanghai) co., Ltd.** The results documented in this report apply only to the tested sample, under the conditions and modes of operation as described herein .Measurement Uncertainties were not taken into account and are published for informational purposes only. This report is written to support regulatory compliance of the applicable standards stated above. This report must not be used by the client to claim product certification, approval, or endorsement by any government agencies.

1.2. Test facility

CNAS (accreditation number: L2264)

TA Technology (Shanghai) Co., Ltd. has obtained the accreditation of China National Accreditation Service for Conformity Assessment (CNAS).

FCC (recognition number is 428261)

TA Technology (Shanghai) Co., Ltd. has been listed on the US Federal Communications Commission list of test facilities recognized to perform electromagnetic emissions measurements.

IC (recognition number is 8510A)

TA Technology (Shanghai) Co., Ltd. has been listed by industry Canada to perform electromagnetic emission measurement.

VCCI (recognition number is C-4595, T-2154, R-4113, G-10766)

TA Technology (Shanghai) Co., Ltd. has been listed by industry Japan to perform electromagnetic emission measurement.

A2LA (Certificate Number: 3857.01)

TA Technology (Shanghai) Co., Ltd. has been listed by American Association for Laboratory Accreditation to perform electromagnetic emission measurement.



1.3. Testing Location

Company: TA Technology (Shanghai) Co., Ltd.
Address: No.145, Jintang Rd, Tangzhen Industry Park, Pudong
City: Shanghai
Post code: 201201
Country: P. R. China
Contact: Xu Kai
Telephone: +86-021-50791141/2/3
Fax: +86-021-50791141/2/3-8000
Website: <http://www.ta-shanghai.com>
E-mail: xukai@ta-shanghai.com

2. General Description of Equipment under Test

Client Information

Applicant	Mobiwire SAS
Applicant address	79 AVENUE FRANCOIS ARAGO 92017 NANTERRE CEDEX France.
Manufacturer	Mobiwire SAS
Manufacturer address	79 AVENUE FRANCOIS ARAGO 92017 NANTERRE CEDEX France.

General information

EUT Description	
Model:	MobiWire Waneta, ALTICE S60
IMEI:	357585080002511
Hardware Version:	V01
Software Version:	WE552_ALTICE_S60
Power Supply:	Battery/AC adapter
Antenna Type:	Internal Antenna
Test Mode:	NFC
Modulation Type:	ASK
Operating Frequency Range(s)	13.56MHz
EUT Accessory	
Adapter	Manufacture: Dongguan Aohai Power Technology Co. Ltd Model : A88-502000
Battery	Manufacturer: NINGBO WEKEN Battery CO,. LTD. Battery Model: 178122390
Earphone	Manufacturer: JuWei Model: JWEP0752-M01
USB cable	Manufacture: JiuJiang Juwei Electronics Co.,Ltd Model : JWBU1344-M01
Note: The information of the EUT is declared by the manufacturer.	



3. Applied Standards

According to the specifications of the manufacturer, it must comply with the requirements of the following standards:

Test standards

- **FCC CFR47 Part 2 (2017)**
- **FCC CFR47 Part 15C (2017)**
- **ANSI C63.10 (2013)**



4. Test Configuration

Test Mode

The EUT was programmed to be in continuously transmitting mode and the transmit duty cycle is not less than 98%.

The EUT has been associated with peripherals and configuration operated in a manner tended to maximize its emission characteristics in a typical application.

5. Test Case Results

5.1. 20dB Bandwidth

Ambient condition

Temperature	Relative humidity	Pressure
23°C ~25°C	45%~50%	101.5kPa

Method of Measurement

The EUT was connected to the spectrum analyzer through an external attenuator (20dB) and a known loss cable. RBW is set to 10 kHz; VBW is set to 3 times thw RBW on spectrum analyzer.

Test Setup

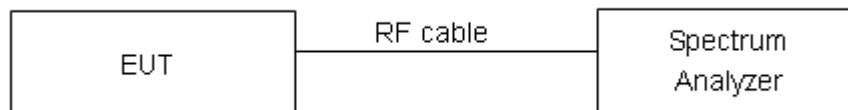

Limits

No specific occupied bandwidth requirements in part 2.1049.

Measurement Uncertainty

The assessed measurement uncertainty to ensure 95% confidence level for the normal distribution is with the coverage factor $k = 2$, $U = 936$ Hz.

**Test Results:**

Carrier frequency (MHz)	99% Bandwidth (kHz)	20dB Bandwidth (kHz)	Conclusion
13.56MHz	23.886	25.16	PASS

5.2. Frequency Stability

Ambient condition

Temperature	Relative humidity
21°C ~25°C	40%~60%

Method of Measurement

1. Frequency Stability (Temperature Variation)

The temperature inside the climate chamber is varied from -20°C to +50°C in 10°C step size,

(1) With all power removed, the temperature was decreased to 0°C and permitted to stabilize for three hours.

(2) Measure the carrier frequency with the test equipment in a “call mode”. These measurements should be made within 1 minute of powering up the mobile station, to prevent significant self warming.

(3) Repeat the above measurements at 10°C increments from -20°C to +50°C. Allow at least 1.5 hours at each temperature, un-powered, before making measurements.

2. Frequency Stability (Voltage Variation)

The frequency stability shall be measured with variation of primary supply voltage as follows:

(1) Vary primary supply voltage from 85 to 115 percent of the nominal value for other than hand carried battery equipment.

(2) For hand carried, battery powered equipment, reduce primary supply voltage to the battery-operating end point which shall be specified by the manufacturer.

This transceiver is specified to operate with an input voltage of between 3.4 V and 4.4 V, with a nominal voltage of 3.85V.

Test setup

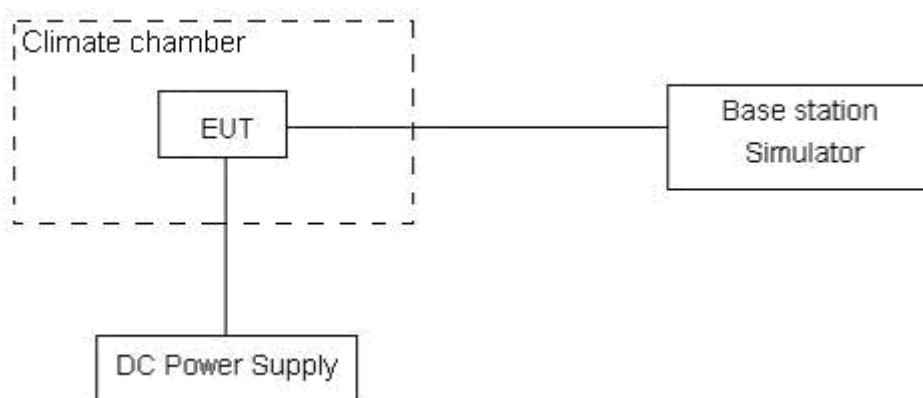

**Limits**

Rule Part 15.225 (e) The frequency tolerance of the carrier signal shall be maintained within $\pm 0.01\%$ of the operating frequency over a temperature variation of -20 degrees to $+ 50$ degrees C at normal supply voltage, and for a variation in the primary supply voltage from 85% to 115% of the rated supply voltage at a temperature of 20 degrees C. For battery operated equipment, the equipment tests shall be performed using a new battery.

Measurement Uncertainty

The assessed measurement uncertainty to ensure 99.75% confidence level for the normal distribution is with the coverage factor $k = 3$, $U = 0.01\text{ppm}$.



Test Result

Test status	Frequency				Tolerance (MHz)			
	13.56MHz				1min	2min	5min	10min
	1min	2min	5min	10min				
-20°C/3.85 V	13.559349	13.559336	13.559342	13.559351	0.000651	0.000664	0.000658	0.000649
-10°C/3.85 V	13.559341	13.559329	13.559339	13.559347	0.000659	0.000671	0.000661	0.000653
0°C/3.85 V	13.559336	13.559319	13.559335	13.559338	0.000664	0.000681	0.000665	0.000662
10°C/3.85 V	13.559333	13.559315	13.559327	13.559335	0.000667	0.000685	0.000673	0.000665
20°C/3.85 V	13.559330	13.559306	13.559325	13.559327	0.000670	0.000694	0.000675	0.000673
30°C/3.85 V	13.559323	13.559300	13.559320	13.559321	0.000677	0.000700	0.000680	0.000679
40°C/3.85 V	13.559322	13.559293	13.559319	13.559312	0.000678	0.000707	0.000681	0.000688
50°C/3.85 V	13.559319	13.559285	13.559310	13.559307	0.000681	0.000715	0.000690	0.000693
20°C/3.6 V	13.559317	13.559278	13.559302	13.559302	0.000683	0.000722	0.000698	0.000698
20°C/4.4 V	13.559317	13.559277	13.559298	13.559293	0.000683	0.000723	0.000702	0.000707

Test status	Tolerance (%)				Limit(%)	Conclusion
	1min	2min	5min	10min		
-20°C/3.85 V	0.004801	0.004897	0.004853	0.004786	0.01	PASS
-10°C/3.85 V	0.004861	0.004950	0.004874	0.004819	0.01	PASS
0°C/3.85 V	0.004899	0.005020	0.004901	0.004883	0.01	PASS
10°C/3.85 V	0.004917	0.005054	0.004964	0.004905	0.01	PASS
20°C/3.85 V	0.004943	0.005117	0.004977	0.004965	0.01	PASS
30°C/3.85 V	0.004991	0.005160	0.005017	0.005004	0.01	PASS
40°C/3.85 V	0.005001	0.005216	0.005025	0.005076	0.01	PASS
50°C/3.85 V	0.005020	0.005269	0.005092	0.005108	0.01	PASS
20°C/3.6 V	0.005038	0.005323	0.005148	0.005151	0.01	PASS
20°C/4.4 V	0.005040	0.005334	0.005178	0.005217	0.01	PASS

5.3. Radiates Emission

Ambient condition

Temperature	Relative humidity	Pressure
23°C ~25°C	45%~50%	102.5kPa

Method of Measurement

The test set-up was made in accordance to the general provisions of ANSI C63.10-2013. The Equipment Under Test (EUT) was set up on a non-conductive table in the semi-anechoic chamber. The test was performed at the distance of 3 m between the EUT and the receiving antenna. The radiated emissions measurements were made in a typical installation configuration.

Sweep the whole frequency band through the range from 9 kHz to the 10th harmonic of the carrier, and the emissions less than 20 dB below the permissible value are reported.

During the test, below 30MHz, the center of the loop shall be 1 meters; above 30MHz, the height of receive antenna shall be moved from 1 to 4 meters, and the antenna shall be performed under horizontal and vertical polarization. The turntable shall be rotated from 0 to 360 degrees for detecting the maximum of radiated spurious signal level. The measurements shall be repeated with orthogonal polarization of the test antenna. The data of cable loss and antenna factor has been calibrated in full testing frequency range before the testing.

Set the spectrum analyzer in the following:

Below 1GHz (detector: Peak and Quasi-Peak)

RBW=100 kHz / VBW=300 kHz / Sweep=AUTO

Above 1GHz (detector: Peak):

(a) PEAK: RBW=1MHz VBW=3MHz/ Sweep=AUTO

(b) AVERAGE: RBW=1MHz / VBW=3MHz / Sweep=AUTO

The radiated emission was measured in the following position: EUT stand-up position (Z axis), lie-down position (X, Y axis). The worst emission was found in stand-up position (Z axis) and the worst case was recorded.

The test is in transmitting mode.

Test setup

9kHz~~~ 30MHz

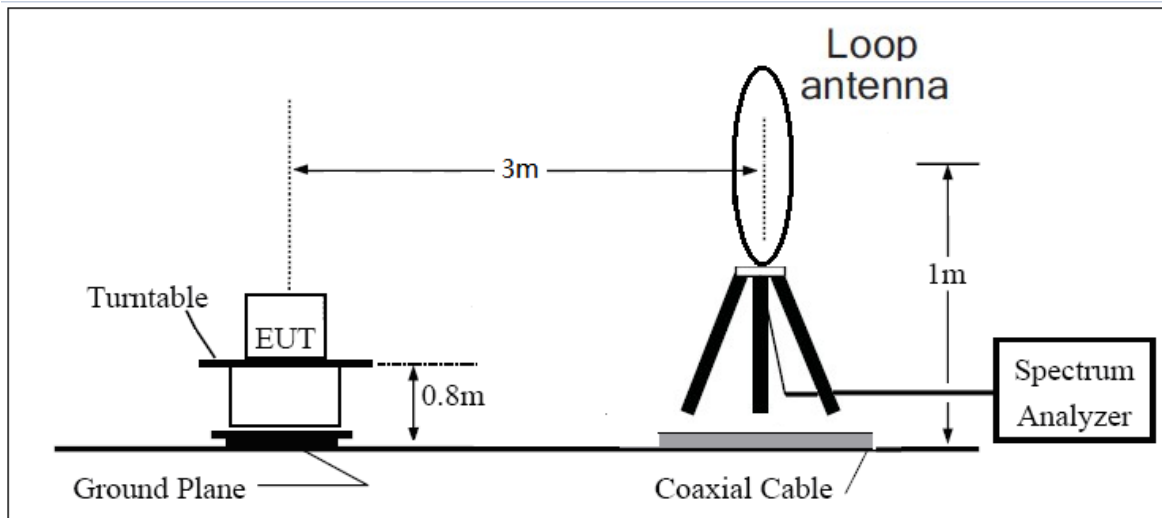

30MHz~~~ 1GHz

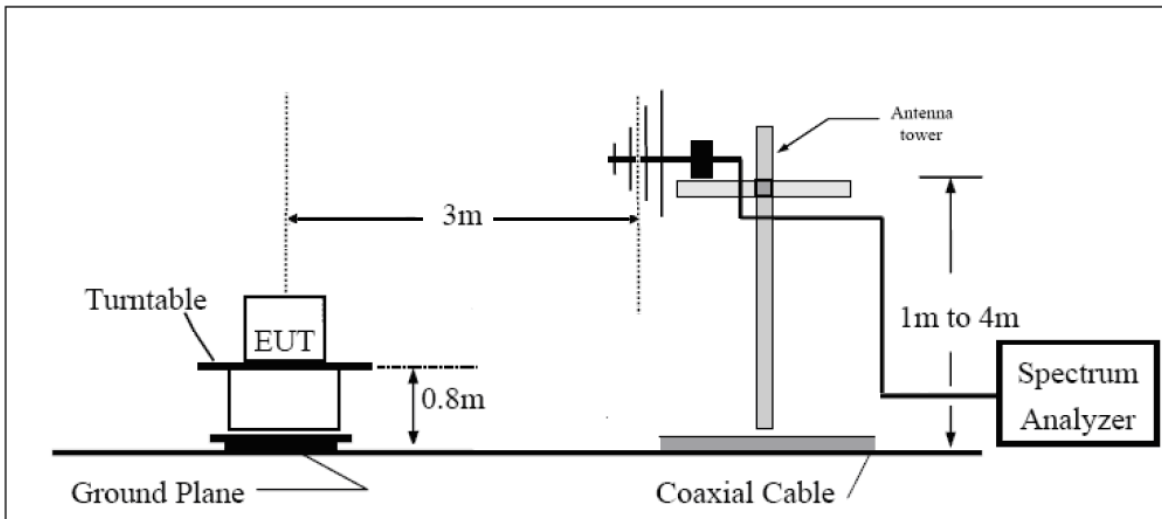

Above 1GHz

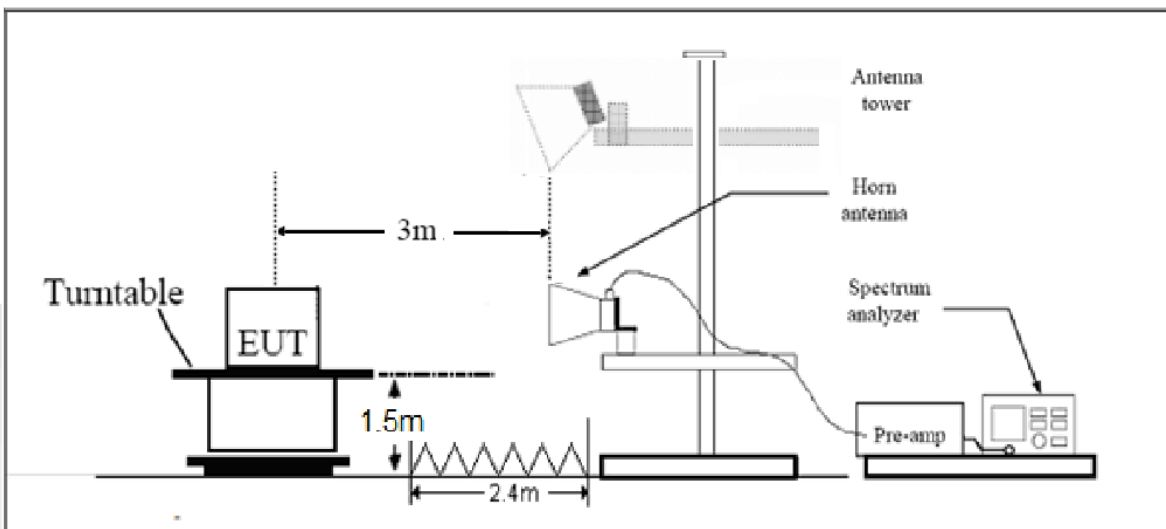

Note: Area side:2.4mX3.6m

Limits

Clause 15.225(a) the field strength of any emissions within the band 13.553-13.567 MHz shall not exceed 15,848 microvolts/meter at 30 meters.

Clause 15.225(b) within the bands 13.410-13.553 MHz and 13.567-13.710 MHz, the field strength of any emissions shall not exceed 334 microvolts/meter at 30 meters.

Clause 15.225(c) within the bands 13.110-13.410 MHz and 13.710-14.010 MHz the field strength of any emissions shall not exceed 106 microvolts/meter at 30 meters.

Clause 15.225(d) The field strength of any emissions appearing outside of the 13.110-14.010 MHz band shall not exceed the general radiated emission limits in §15.209.

§15.209 (a) Except as provided elsewhere in this subpart, the emissions from an intentional radiator shall not exceed the field strength levels specified in the following table:

Frequency of emission (MHz)	Field strength(uV/m)	Field strength(dBuV/m)
0.009–0.490	2400/F(kHz)	/
0.490–1.705	24000/F(kHz)	/
1.705–30.0	30	/
30-88	100	40
88-216	150	43.5
216-960	200	46
Above960	500	54

**Except as provided in paragraph (g), fundamental emissions from intentional radiators operating under this section shall not be located in the frequency bands 54-72 MHz, 76-88 MHz, 174-216 MHz or 470-806 MHz. However, operation within these frequency bands is permitted under other sections of this part, e.g., §§15.231 and 15.241.

§15.209 (b) In the emission table above, the tighter limit applies at the band edges.

§15.209 (d) The emission limits shown in the above table are based on measurements employing a CISPR quasi-peak detector except for the frequency bands 9-90 kHz, 110-490 kHz and above 1000 MHz. Radiated emission limits in these three bands are based on measurements employing an average detector.

Measurement Uncertainty

The assessed measurement uncertainty to ensure 95% confidence level for the normal distribution is with the coverage factor $k = 1.96$.

Frequency	Uncertainty
9kHz-30MHz	3.55 dB
30MHz-200MHz	4.19 dB
200MHz-1GHz	3.63 dB
Above 1GHz	3.68 dB

Test result**In-band**

FCC RE Part15C 13.56M

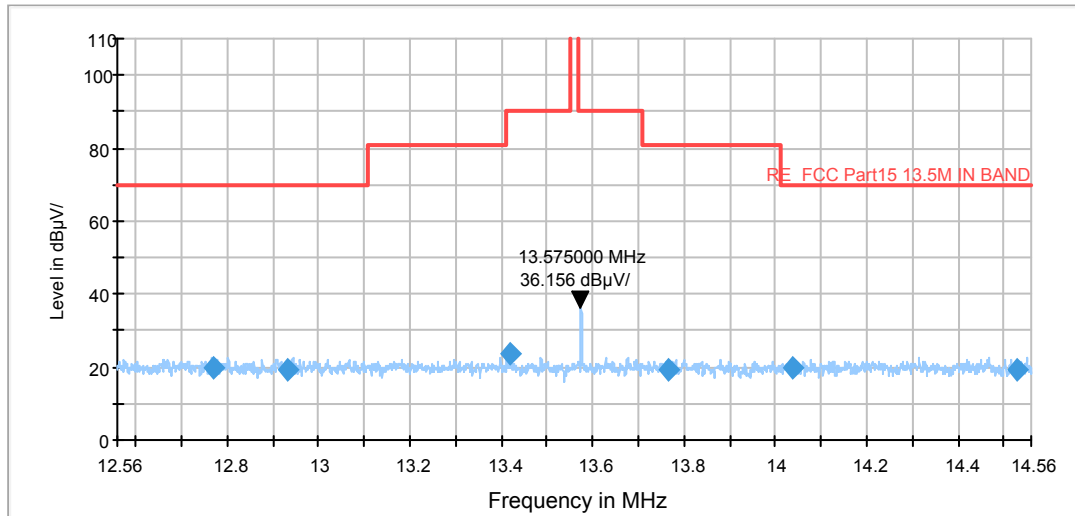

Radiates Emission from 12.56MHz to 14.56MHz

Note: This graph displays the maximum values of horizontal and vertical by software

Out-of-band

The following graphs display the maximum values of horizontal and vertical by software.
 For above 1GHz, Blue trace uses the peak detection, Green trace uses the average detection.

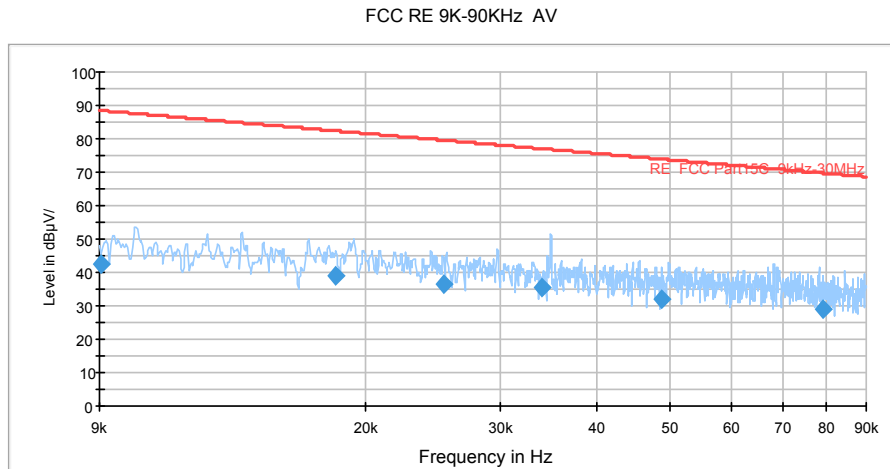

Radiates Emission from 9kHz to 90kHz

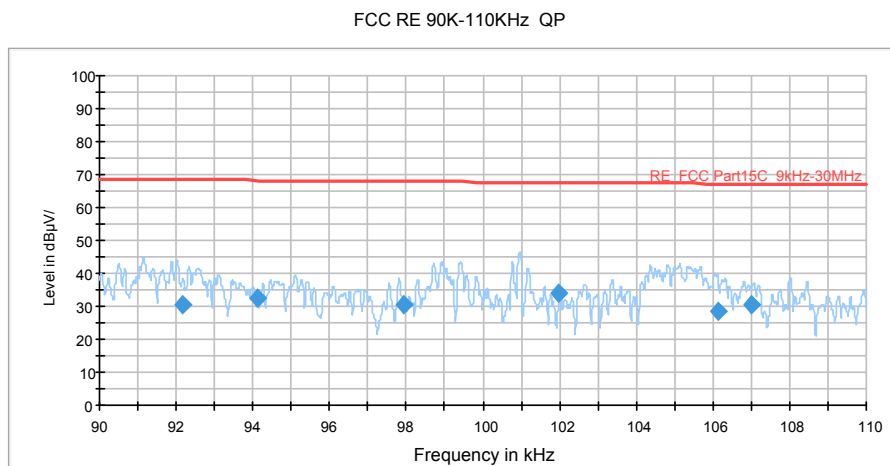

Radiates Emission from 90kHz to 110kHz

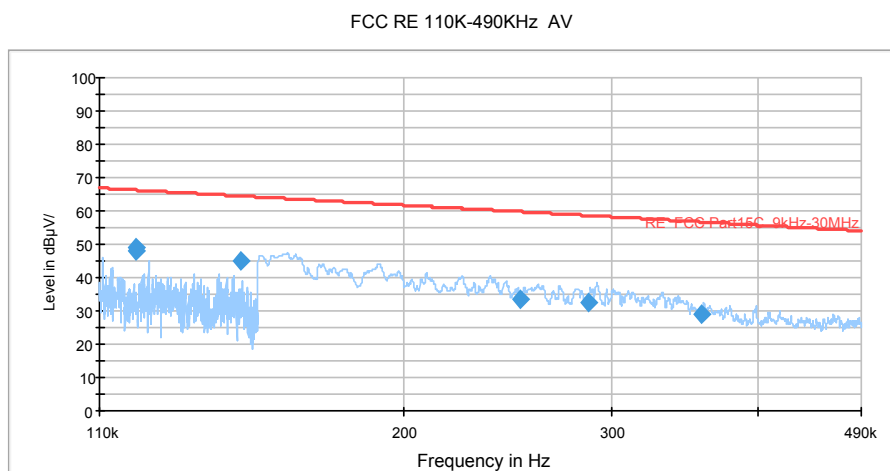

Radiates Emission from 110kHz to 490kHz

FCC RE 490K-30MHz QP

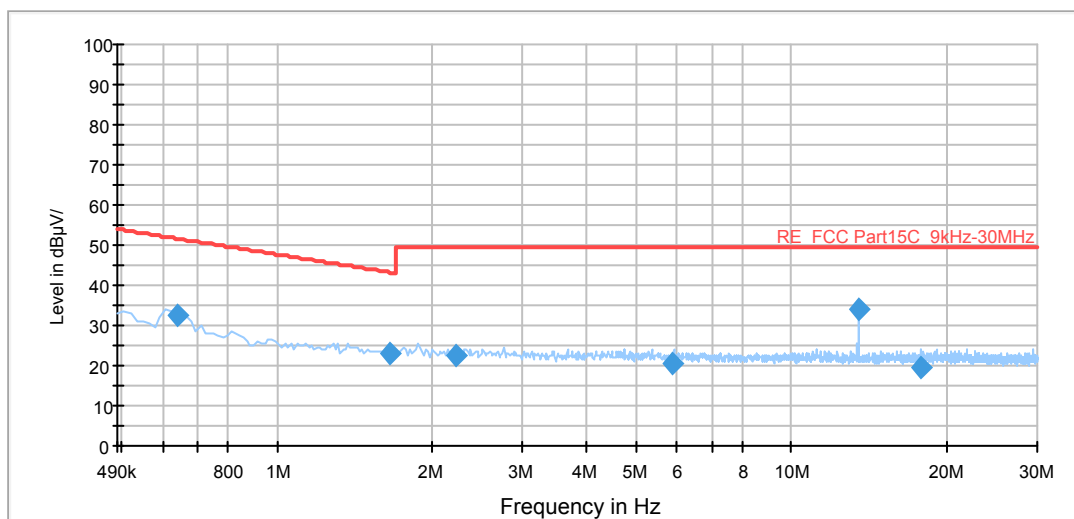

Radiates Emission from 490kHz to 30MHz

Frequency (MHz)	Quasi-Peak (dBuV/m)	Height (cm)	Azimuth (deg)	Reading value (dBuV/m)	Correct Factor (dB)	Margin (dB)	Limit (dBuV/m)
0.640550	32.6	100.0	0.0	13.1	19.5	19.0	51.6
1.652155	23.0	100.0	0.0	3.8	19.2	20.2	43.3
2.231335	22.6	100.0	141.0	3.5	19.1	26.9	49.5
5.884085	20.6	100.0	0.0	1.3	19.3	28.9	49.5
13.563175	34.0	100.0	0.0	14.5	19.5	15.5	49.5
17.760615	19.6	100.0	0.0	0.0	19.6	29.9	49.5

- Remark: 1. Quasi-Peak = Reading value + Correction factor
 2. Correction Factor = Antenna factor+ Insertion loss (cable loss+amplifier gain)
 3. Margin = Limit – Quasi-Peak



FCC RE 0.03-1GHz QP Class B

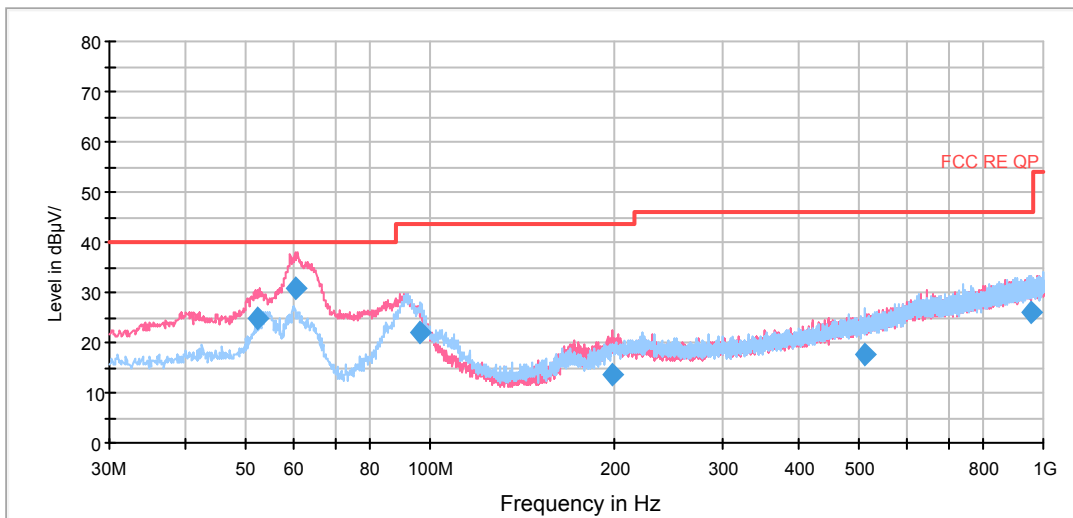

Radiates Emission from 30MHz to 1GHz

Note: This graph displays the maximum values of horizontal and vertical by software

Frequency (MHz)	Quasi-Peak (dBuV/m)	Height (cm)	Polarization	Azimuth (deg)	Reading value (dBuV/m)	Correct Factor (dB)	Margin (dB)	Limit (dBuV/m)
52.273750	24.7	100.0	V	304.0	11.8	12.9	15.3	40.0
60.431250	30.8	100.0	V	333.0	18.4	12.4	9.2	40.0
95.966250	22.2	200.0	H	150.0	9.4	12.8	21.3	43.5
198.010000	13.7	100.0	V	205.0	1.8	11.9	29.8	43.5
513.055000	17.7	125.0	H	39.0	-3.2	20.9	28.3	46.0
955.416250	25.9	200.0	H	257.0	-1.4	27.3	20.1	46.0

5.4. Conducted Emission

Ambient condition

Temperature	Relative humidity	Pressure
23°C ~25°C	45%~50%	101.5kPa

Methods of Measurement

The EUT is placed on a non-metallic table of 80cm height above the horizontal metal reference ground plane. During the test, the EUT was operating in its typical mode. The test method is according to ANSI C63.10-2013. Connect the AC power line of the EUT to the L.I.S.N. Use EMI receiver to detect the average and Quasi-peak value. RBW is set to 9 kHz, VBW is set to 30kHz. The measurement result should include both L line and N line. The test is in transmitting mode.

Test Setup

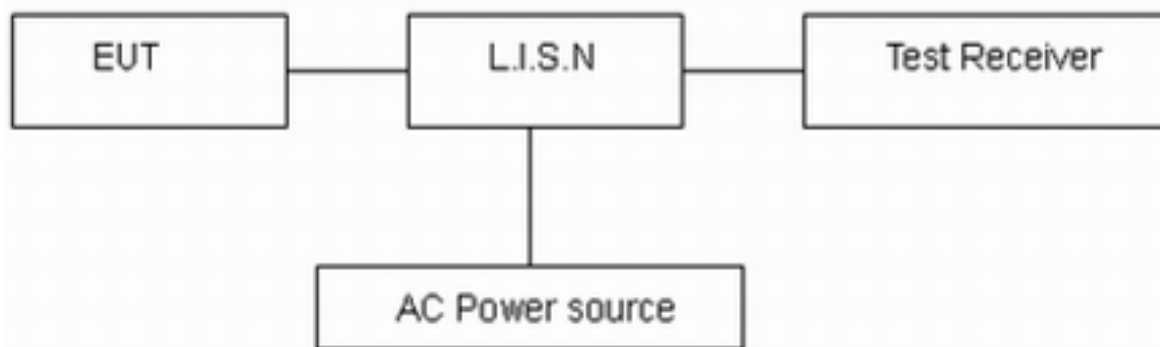

Note: AC Power source is used to change the voltage 110V/60Hz.

Limits

§15.207 (a) Except as shown in paragraphs (b) and (c) of this section, for an intentional radiator that is designed to be connected to the public utility (AC) power line, the radio frequency voltage that is conducted back onto the AC power line on any frequency or frequencies, within the band 150 kHz to 30 MHz, shall not exceed the limits in the following table, as measured using a 50 μH/50 ohms line impedance stabilization network (LISN). Compliance with the provisions of this paragraph shall be based on the measurement of the radio frequency voltage between each power line and ground at the power terminal. The lower limit applies at the boundary between the frequency ranges.

Frequency (MHz)	Conducted Limits(dBμV)	
	Quasi-peak	Average
0.15 - 0.5	66 to 56 *	56 to 46 *
0.5 - 5	56	46



5 - 30	60	50
*: Decreases with the logarithm of the frequency.		

Measurement Uncertainty

The assessed measurement uncertainty to ensure 95% confidence level for the normal distribution is with the coverage factor $k = 1.96$, $U = 2.69$ dB.



Test Results:

Following plots, Blue trace uses the peak detection and Green trace uses the average detection.

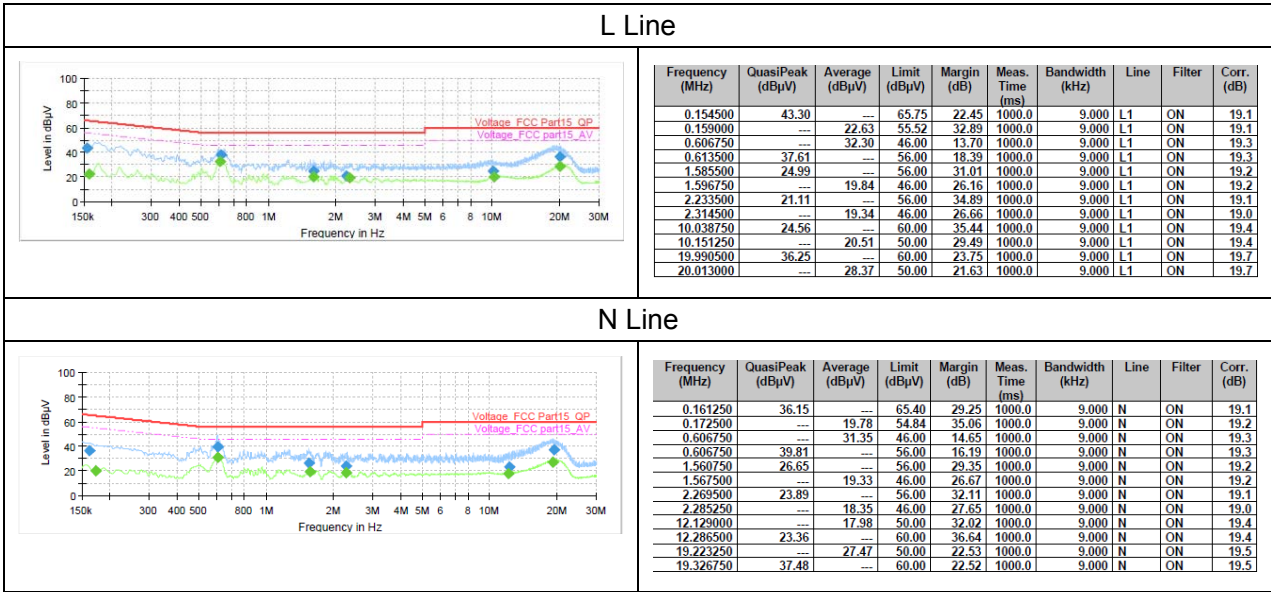



6. Main Test Instruments

Name	Manufacturer	Type	Serial Number	Calibration Date	Expiration Time
Spectrum Analyzer	R&S	FSV30	100815	2016-12-16	2017-12-15
EMI Test Receiver	R&S	ESCI	100948	2017-05-20	2018-05-19
TRILOG Broadband Antenna	Schwarzbeck	VULB 9163	9163-201	2014-12-06	2017-12-05
Loop Antenna	SCHWARZBECK	FMZB1519	1519-047	2017-02-18	2020-02-17
EMI Test Receiver	R&S	ESCS30	100138	2016-12-16	2017-12-15
LISN	R&S	ENV216	101171	2016-12-16	2019-12-15
Spectrum Analyzer	Agilent	N9020A	MY52330084	2017-05-14	2018-05-13
RF Cable	Agilent	SMA 15cm	0001	2017-04-06	2017-08-05
TEMPERATURE CHAMBER	ESPEC	SU-242	93000506	2016-12-27	2017-12-26

*****END OF REPORT *****

ANNEX A: EUT Appearance and Test Setup

A.1 EUT Appearance

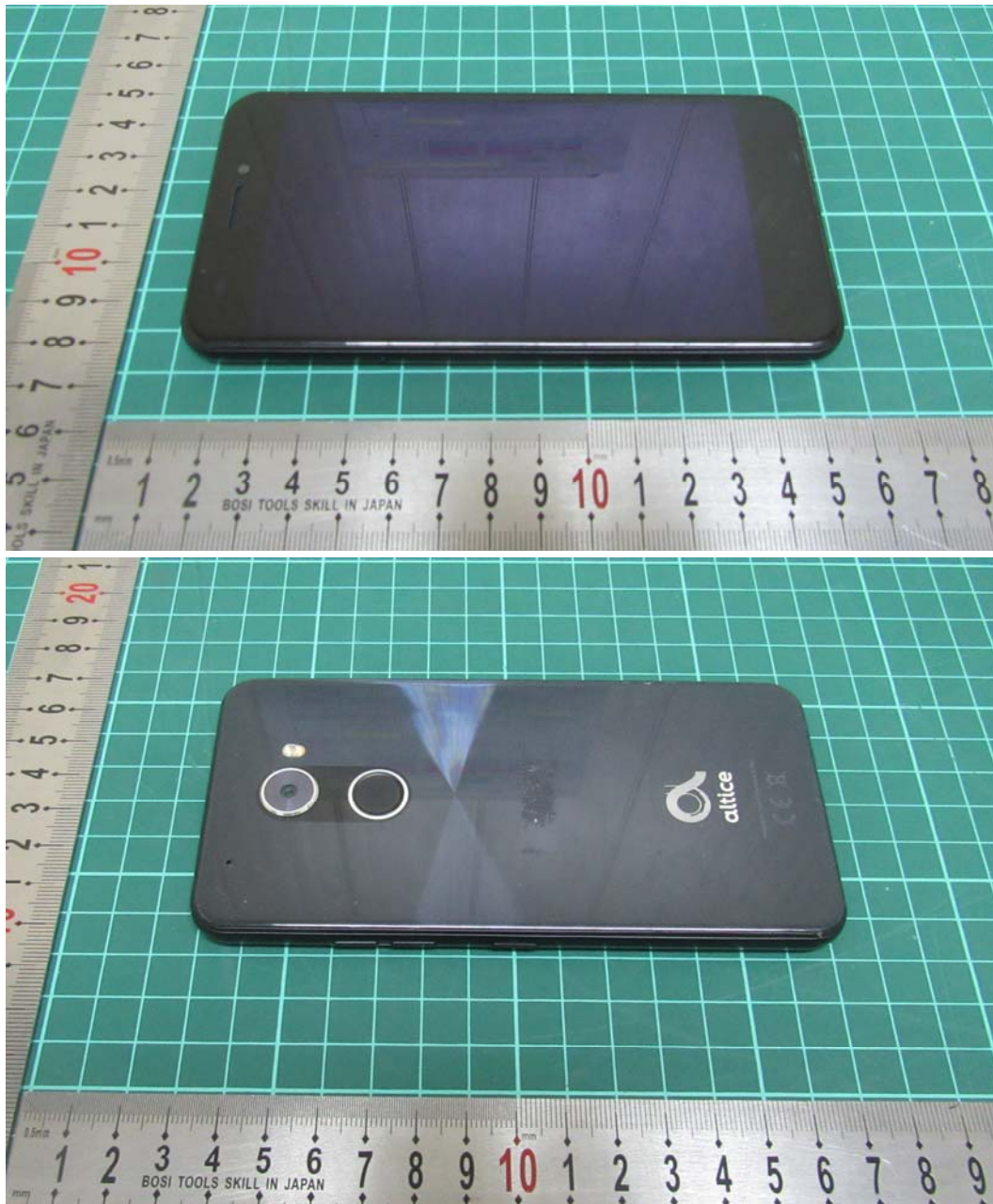

Picture 1-1: EUT

Picture 1 EUT and Accessory

A.2 Test Setup

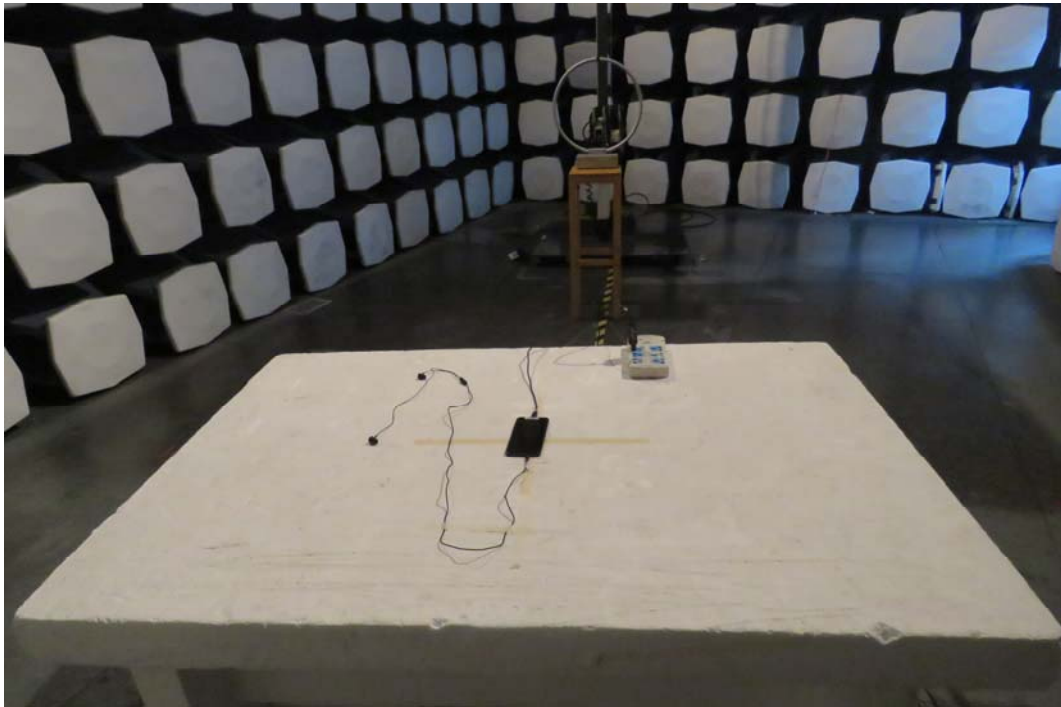

9kHz - 30MHz

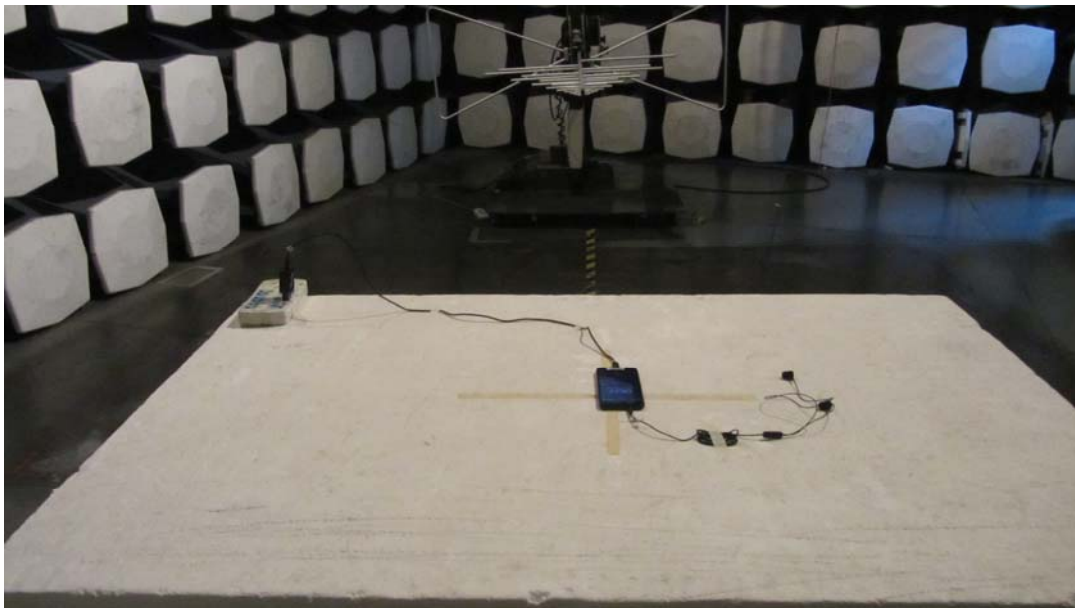

30M Hz-1GHz

Picture 2 Radiated Emission Test Setup



Picture 3 Conducted Emission Test Setup