



## TEST REPORT

No. I20D00115-EMC01

*For*

**Client : MobiWire SAS**

**Production : 4G Smart Phone**

**Model Name : MobiWire Sora |H5024,Smart E11 (H5024)**

**Brand Name: MobiWire,Vodafone**

**FCC ID: QPN-SORA**

**Hardware Version: V01A**

**Software Version: SORA\_EU\_V01\_200630**

**Issued date: 2020-09-11**

## NOTE

1. The test results in this test report relate only to the devices specified in this report.
2. This report shall not be reproduced except in full without the written approval of East China Institute of Telecommunications
3. The measurement uncertainty is not taken into account when deciding conformity, and the results of measurement (or the average of measurement results) are directly used as the criterion for the stating conformity.

**Test Laboratory:**

East China Institute of Telecommunications

Add: Building 4, No. 766, Jingang Road, Pudong New District, Shanghai

Tel: +862163843300

E-Mail: [welcome@ecit.org.cn](mailto:welcome@ecit.org.cn)

**Revision Version**

<b>Report Number</b>	<b>Revision</b>	<b>Date</b>	<b>Memo</b>
I20D00115-EMC01	00	2020-08-19	Initial creation of test report
I20D00115-EMC01	01	2020-09-11	Second creation of test report

## CONTENTS

1. TEST LABORATORY .....	6
1.1. TESTING LOCATION .....	6
1.2. TESTING ENVIRONMENT .....	6
1.3. PROJECT DATA .....	6
1.4. SIGNATURE .....	6
2. CLIENT INFORMATION .....	7
2.1. APPLICANT INFORMATION .....	7
2.2. MANUFACTURER INFORMATION .....	7
3. EQUIPMENT UNDER TEST (EUT) AND ANCILLARY EQUIPMENT (AE) .....	8
3.1. ABOUT EUT .....	8
3.2. INTERNAL IDENTIFICATION OF EUT USED DURING THE TEST .....	8
3.3. INTERNAL IDENTIFICATION OF AE USED DURING THE TEST .....	8
4. REFERENCE DOCUMENTS.....	9
4.1 REFERENCE DOCUMENTS FOR TESTING .....	9
5. TEST RESULTS.....	10
5.1 SUMMARY OF TEST RESULTS .....	10
5.2 STATEMENTS.....	10
6. TEST EQUIPMENT UTILIZED .....	11
6.1 RADIATED EMISSION EQUIPMENT LIST .....	11
6.1 AC CONDUCTED EMISSION EQUIPMENT LIST .....	11
7. SYSTEM CONFIGURATION DURING TEST .....	13
7.1 TEST MODE.....	13
7.2 CONNECTION DIAGRAM OF TEST SYSTEM.....	14
8. MEASUREMENT RESULTS .....	15
8.1 RADIATED EMISSION 30MHZ-18GHZ.....	15

<b>8.2 AC CONDUCTED EMISSION.....</b>	<b>19</b>
<b>ANNEX A ACCREDITATION CERTIFICATE .....</b>	<b>21</b>

## 1. Test Laboratory

### 1.1. Testing Location

Company Name:	ECIT Shanghai, East China Institute of Telecommunications
Address:	Building 4, No. 766, Jingang Road, Pudong New District, Shanghai
Postal Code:	201206
Telephone:	(+86)-021-63843300
FCC registration No:	958356
FCC designation No:	CN1177

### 1.2. Testing Environment

Normal Temperature:	15-35°C
Relative Humidity:	30-60% RH
Supply Voltage	120V/60Hz

### 1.3. Project data

Project Leader:	Yu Anlu
Testing Start Date:	2020-08-07
Testing End Date:	2020-08-13

### 1.4. Signature

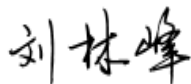

**Liu Linfeng**  
(Prepared this test report)



**Qin Yabin**  
(Reviewed this test report)

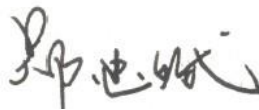

**Zheng Zhongbin**  
(Approved this test report)

## 2. Client Information

### 2.1. Applicant Information

Company Name	MobiWire SAS
Address	79 avenue Francois Arago, 92000 NANTERRE France.
Telephone	+86 574 59555707
Postcode	NA

### 2.2. Manufacturer Information

Company Name	MobiWire SAS
Address	79 avenue Francois Arago, 92000 NANTERRE France.
Telephone	+86 574 59555707
Postcode	NA

### 3. Equipment under Test (EUT) and Ancillary Equipment (AE)

#### 3.1. About EUT

Product Name	4G Smart Phone
Model name	MobiWire Sora  H5024,Smart E11 (H5024)
GSM Frequency Band	GSM850/GSM900/ GSM1800/GSM1900
UMTS Frequency Band	Band I /Band II /Band V /Band VIII
LTE Frequency Band	LTE 1/3/7/20
Additional Communication Function	BT5.0;WLAN 802.11a,b,g,n;GPS;GLONASS;FM;

#### 3.2. Internal Identification of EUT used during the test

EUT ID*	SN or IMEI	HW Version	SW Version	Date of receipt
N03	354392850000301	V01A	SORA_EU_V01_200630	2020-08-07

\*EUT ID: is used to identify the test sample in the lab internally.

#### 3.3. Internal Identification of AE used during the test

AE ID*	Description	Model	SN
CA01	Adapter	A31A-050100U_EU1	NA
CC06	Adapter	A806A-050100U-UK1	NA
UA07	USB Cable	AM/MICRO5P	NA
AA01	Earphone	JWEP0957-M01	NA
BA23	Battery	178191212	9112G0050100552
AE1	Notebook PC	DELL Latitude E6510	NA
AE2	Desktop PC	OptiPlex 790 DT	X8RP1 A01 APCC
AE3	LAN Cable	NA	NA
AE4	VGA Cable	NA	NA
AE5	RS232 Cable	NA	NA
AE6	Keyboard	KB212-B	CN-0Y88XT-65890-12I-005Q-A00
AE7	Mouse	MS111-P	CN-011D3V-71581-19J-1A64
AE8	SanDiskUltra64 GB	microSDXC 1	NA
AE9	Monitor	Dell E1709Wc	NA

\*AE ID: is used to identify the test sample in the lab internally.



## 4. Reference Documents

### 4.1 Reference Documents for testing

The following documents listed in this section are referred for testing.

Reference	Title	Version
FCC Part 15, Subpart B	Radio frequency devices	2020/06/29
ANSI C63.4	Method of Measurement of Radio-Noise Emissions from Low-Voltage Electrical and Electronic Equipment in the Range of 9 kHz to 40 GHz	2014

## 5. Test Results

### 5.1 Summary of Test Results

Items	Test List	Clause in FCC rules	Verdict
1	Radiated Emission	15.109(a)	Pass
2	AC Conducted Emission	15.107(a)	Pass

### 5.2 Statements

The MobiWire Sora |H5024,Smart E11 (H5024), supporting GSM/WCDMA/LTE.etc, manufactured by MobiWire SAS is a variant product for testing. ECIT only performed test cases which identified with Pass/Fail/Inc result in section 5.1.

ECIT has verified that the compliance of the tested device specified in section 3 of this test report is successfully evaluated according to the procedure and test methods as defined in type certification requirement listed in section 4 of this test report.

Note: The project changed Battery, Hardware based on the I19D00035-EMC01 original report, test content for the original report of the worst mode, embodied in the report data is the worst mode. Other information reference original report.

Note: This project is a variant of the original report I90D00035-EMC01, test content for the original report of the worst mode, embodied in the report data is the worst mode. Other information reference original report.

## 6. Test Equipment Utilized

### 6.1 Radiated Emission Equipment list

Item	Instrument Name	Type	Serial Number	Manufacturer	Cal. Date	Cal. interval
1	Universal Radio Communication Tester	CMU200	123126	R&S	2020-05-10	1 year
2	Universal Radio Communication Tester	CMW500	104178	R&S	2020-05-10	1 year
3	Test Receiver	ESU40	100307	R&S	2020-05-10	1 year
4	Trilog Antenna	VULB9163	VULB9163-5 15	Schwarzbeck	2020-02-28	2 years
5	Double Ridged Guide	ETS-3117	00135890	ETS	2020-02-28	2 years
6	EMI Test Software	EMC32 V9.15	NA	R&S	NA	NA
7	Signal Generator	SMF 100A	102314	R&S	2020-05-10	1 year
8	GPS Simulator	GSS 4200	1182	SPIRENT	2019-12-11	1 year
9	Signal Generator	SMBV100 A	105563	R&S	2020-03-18	1 year

### 6.1 AC Conducted Emission Equipment list

Item	Instrument Name	Type	Serial Number	Manufacturer	Cal. Date	Cal. interval
1	Universal Radio Communication Tester	CMU200	123123	R&S	2020-05-10	1 year
2	Universal Radio Communication Tester	CMW500	104178	R&S	2020-05-10	1 year
3	Test Receiver	ESCI	101235	R&S	2020-05-10	1 year
4	2-Line V-Network	ENV216	101380	R&S	2020-03-17	1 year
5	EMI Test Software	EMC32 V10.35.02	NA	R&S	NA	NA

6	Signal Generator	SMF 100A	102314	R&S	2020-05-10	1 year
7	GPS Simulator	GSS 4200	1182	SPIRENT	2019-12-11	1 year
8	Signal Generator	SMB 100A	257984	R&S	2020-05-10	1 year

## 7. System Configuration during Test

### 7.1 Test Mode

Test Item	Function Type
AC Conducted Emission	Mode 1: Adapter charging+ GSM 850 receiver + CA01 <Figure 2> Mode 2: Adapter charging+ GSM 850 receiver + CC06<Figure 2>
Radiated Emission	Mode 1: Adapter charging+ GSM 850 receiver + CA01 <Figure 2> Mode 2: Adapter charging+ GSM 850 receiver + CC06<Figure 2> Mode3: USB cable (Data Link with PC) <Figure 1>
Remark: 1. All test modes are performed, only the worst cases test data are recorded in this report. 2. Data Link with PC means data application transferred mode between EUT and PC. 3. After laboratory verification, GSM850 is the worst mode among all receiving modes of GSM/WCDMA/LTE and is recorded in the report.	

### 7.2 Connection Diagram of Test System

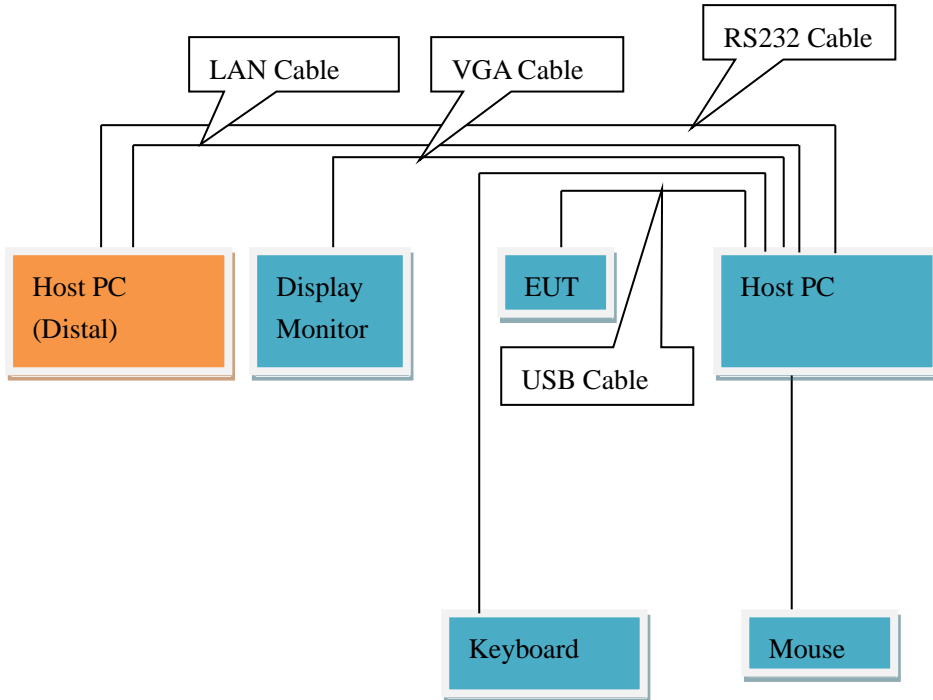

<Figure 1>

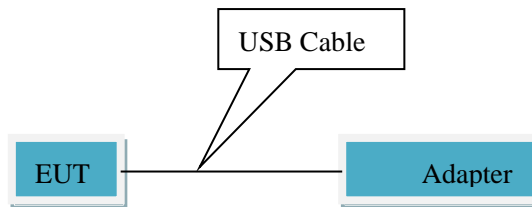

<Figure 2>

## 8. Measurement Results

Only the worst test result was shown in this report.

### 8.1 Radiated Emission 30MHz-18GHz

#### Method of Measurement

For 30MHz -1000MHz, the EUT was placed on the top of a rotating 0.8m table above the ground at a semi-anechoic chamber. The distance between the EUT and the received antenna was 3 meters. The table was rotated 360 degree and the received antenna mounted on a variable-height antenna tower was varied from 1m to 4m to find the maximum value of the field strength. Both horizontal and vertical polarizations of the antenna were set during the measurement. Tested in accordance with the procedures of ANSI C63.4-2014, section 8.3.

For 1000MHz-18000MHz, The maximal emission value was acquired by adjusting the antenna height, The table was rotated 360 degree to determine the maximum value of the field strength. Both horizontal and vertical polarizations of the antenna were set during the measurement.

#### Limits for Radiated Emission at a measuring distance of 3m

Frequency Range (MHz)	Quasi-Peak (dBuV/m)
30-88	40
88-216	43.5
216-960	46
Above 960	54

Frequency Range (MHz)	Peak (dBuV/m)	Average (dBuV/m)
Above 1000	74	54

#### Test conditions

Frequency Range (MHz)	RBW/VBW	Sweep Time (s)
30-1000	120kHz/300kHz	Auto
1000-18000	1MHz/3MHz	Auto

#### Uncertainty Measurement

The measurement uncertainty (30MHz-1000MHz) is 4.82 dB (k=2).

The measurement uncertainty (1000MHz-18000MHz) is 5.08 dB (k=2).

**Test Results**

Sweep the whole frequency band through the range from 30MHz to the 5<sup>th</sup> harmonic of the carrier, the Emissions in the frequency band 18GHz-40GHz is more than 20dB below the limit are not report.

Mode3: USB cable (Data Link with PC) <Figure 1>

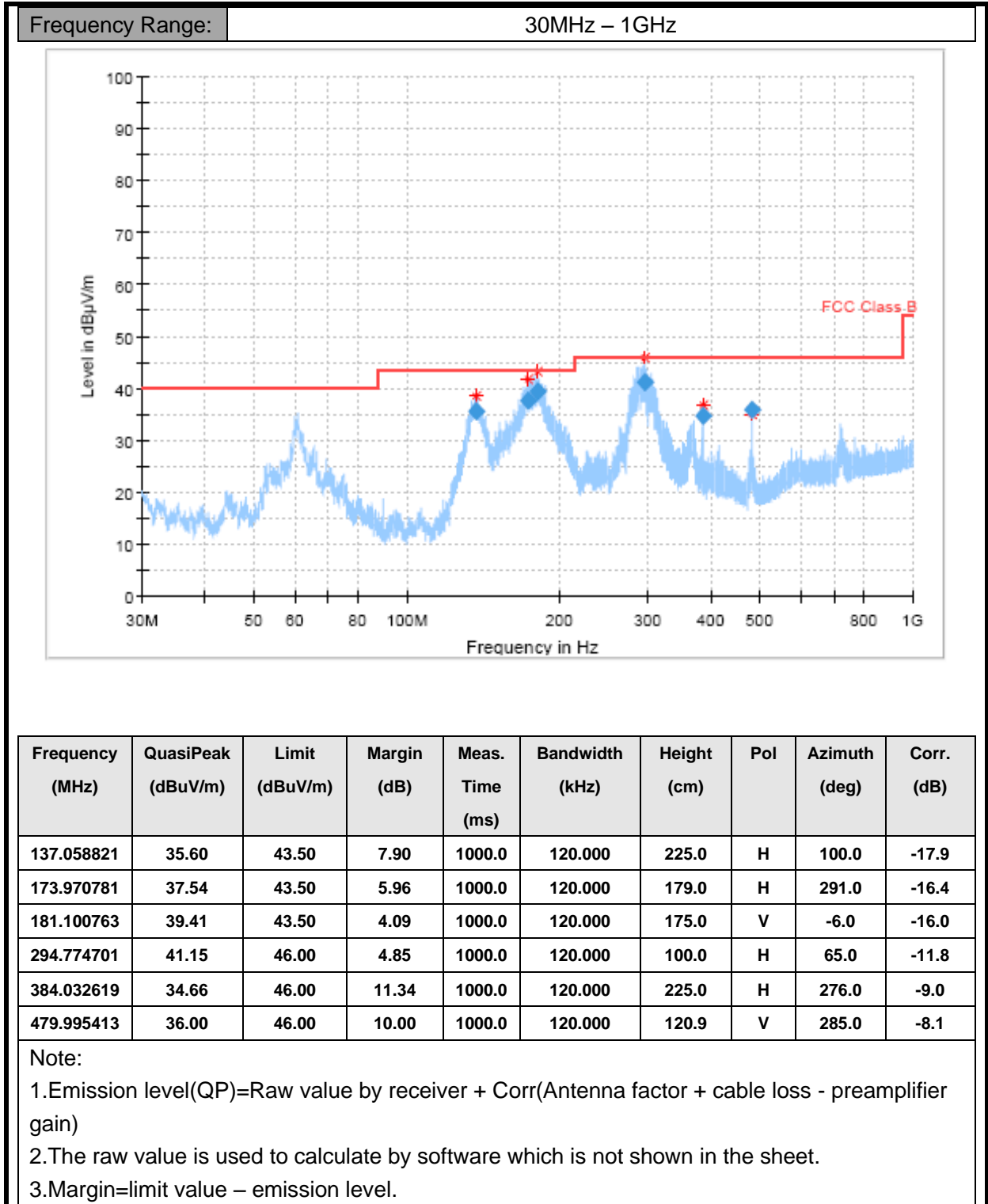



Mode3: USB cable (Data Link with PC) <Figure 1>

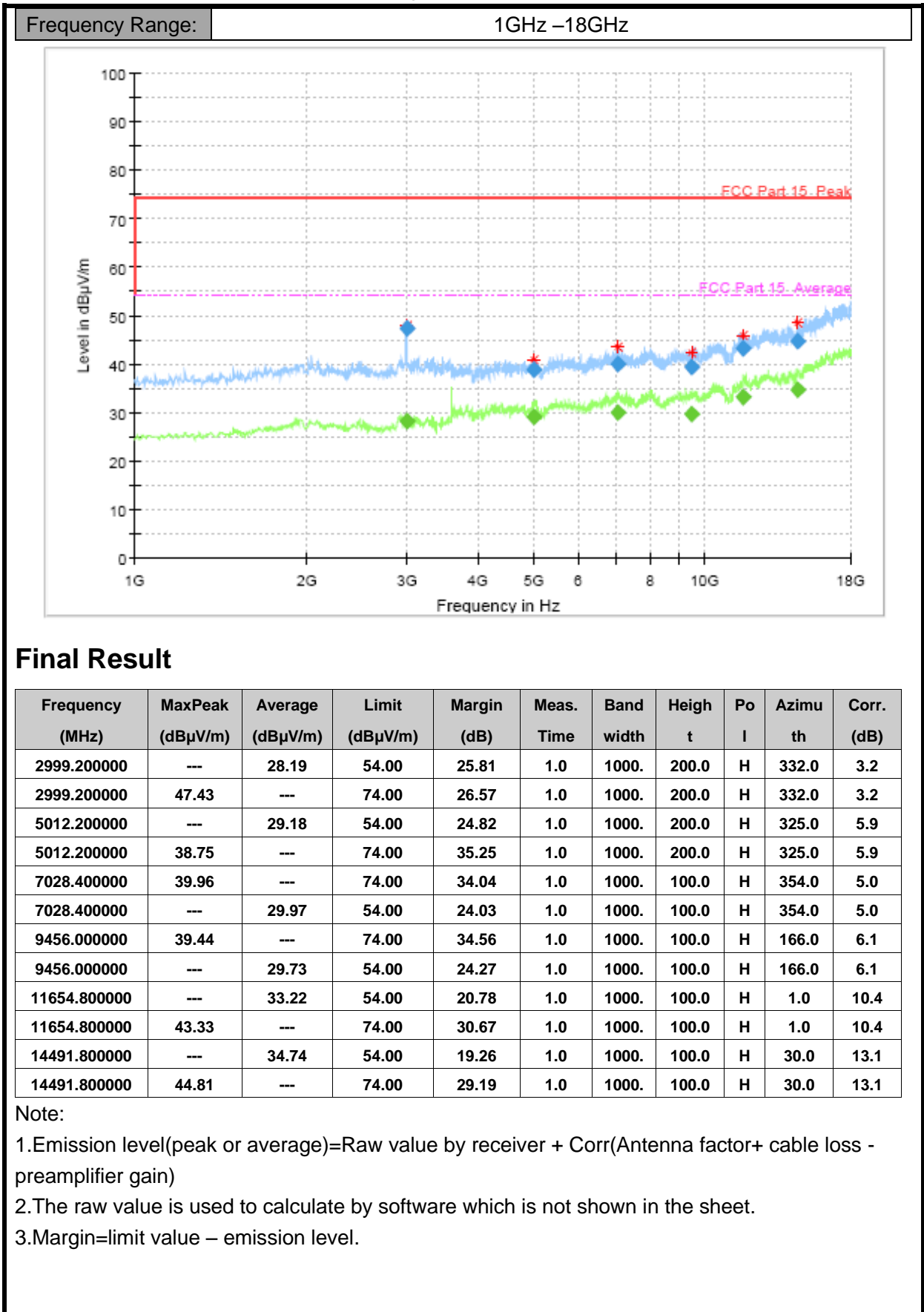

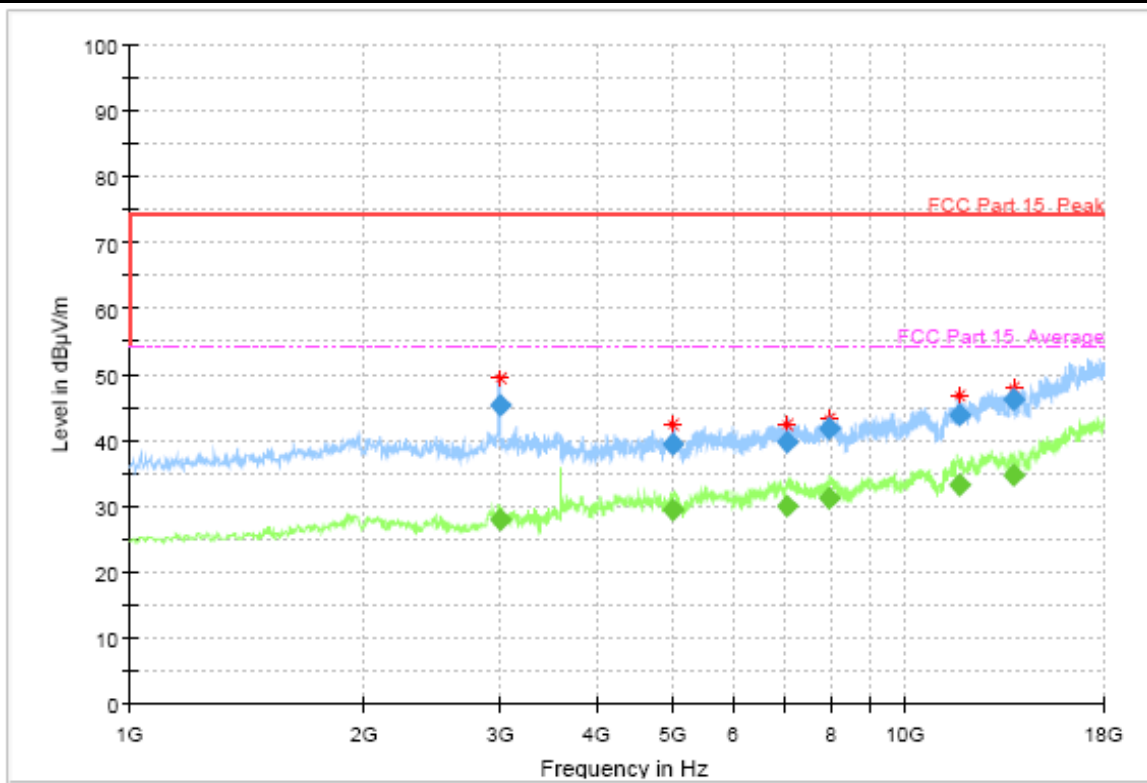

### Final Result

Frequency (MHz)	MaxPeak (dBuV/m)	Average (dBuV/m)	Limit (dBuV/m)	Margin (dB)	Meas. Time	Bandwidth	Height	Polarization	Azimuth	Corr. (dB)
2998.800000	45.32	---	74.00	28.68	1.0	1000.00	100.0	V	117.0	3.2
2998.800000	---	27.85	54.00	26.15	1.0	1000.00	100.0	V	117.0	3.2
5019.800000	---	29.33	54.00	24.67	1.0	1000.00	200.0	V	278.0	6.0
5019.800000	39.43	---	74.00	34.57	1.0	1000.00	200.0	V	278.0	6.0
7046.000000	---	30.00	54.00	24.00	1.0	1000.00	100.0	V	4.0	5.0
7046.000000	39.75	---	74.00	34.25	1.0	1000.00	100.0	V	4.0	5.0
7956.200000	---	31.15	54.00	22.85	1.0	1000.00	200.0	V	235.0	5.4
7956.200000	41.90	---	74.00	32.10	1.0	1000.00	200.0	V	235.0	5.4
11753.200000	43.84	---	74.00	30.16	1.0	1000.00	200.0	V	250.0	10.4
11753.200000	---	33.30	54.00	20.70	1.0	1000.00	200.0	V	250.0	10.4
13739.000000	---	34.63	54.00	19.37	1.0	1000.00	200.0	V	358.0	12.1
13739.000000	46.03	---	74.00	27.97	1.0	1000.00	200.0	V	358.0	12.1

Note:

- 1.Emission level(peak or average)=Raw value by receiver + Corr(Antenna factor+ cable loss - preamplifier gain)
- 2.The raw value is used to calculate by software which is not shown in the sheet.
- 3.Margin=limit value – emission level.

## 8.2 AC Conducted Emission

### Method of Measurement

For equipment that is designed to be connected to the public utility (AC) power line, the radio frequency voltage that is conducted back onto the AC power line on any frequency or frequencies with the band 150 kHz to 30MHz shall not exceed the limits. Both lines of the power mains connected to the EUT were checked for maximum conducted interference. Tested in accordance with the procedures of ANSI C63.4-2014, section 7.3

### Limit of Conducted Emission

Frequency Range (MHz)	Conducted Limit (dBuV)	
	Quasi-peak	Average
0.15-0.5	66 to 56*	56 to 46*
0.5-5	56	46
5-30	60	50

\*Decreases with the logarithm of the frequency

### Test Condition in Charging Mode

Voltage (V)	Frequency (Hz)	RBW	Sweep Time (s)
120	60	9 kHz	Auto

### Uncertainty Measurement

The measurement uncertainty is 3.58dB (k=2).

### Test Results

Mode 1: Adapter charging+ GSM 850 receiver + CA01 <Figure 2>

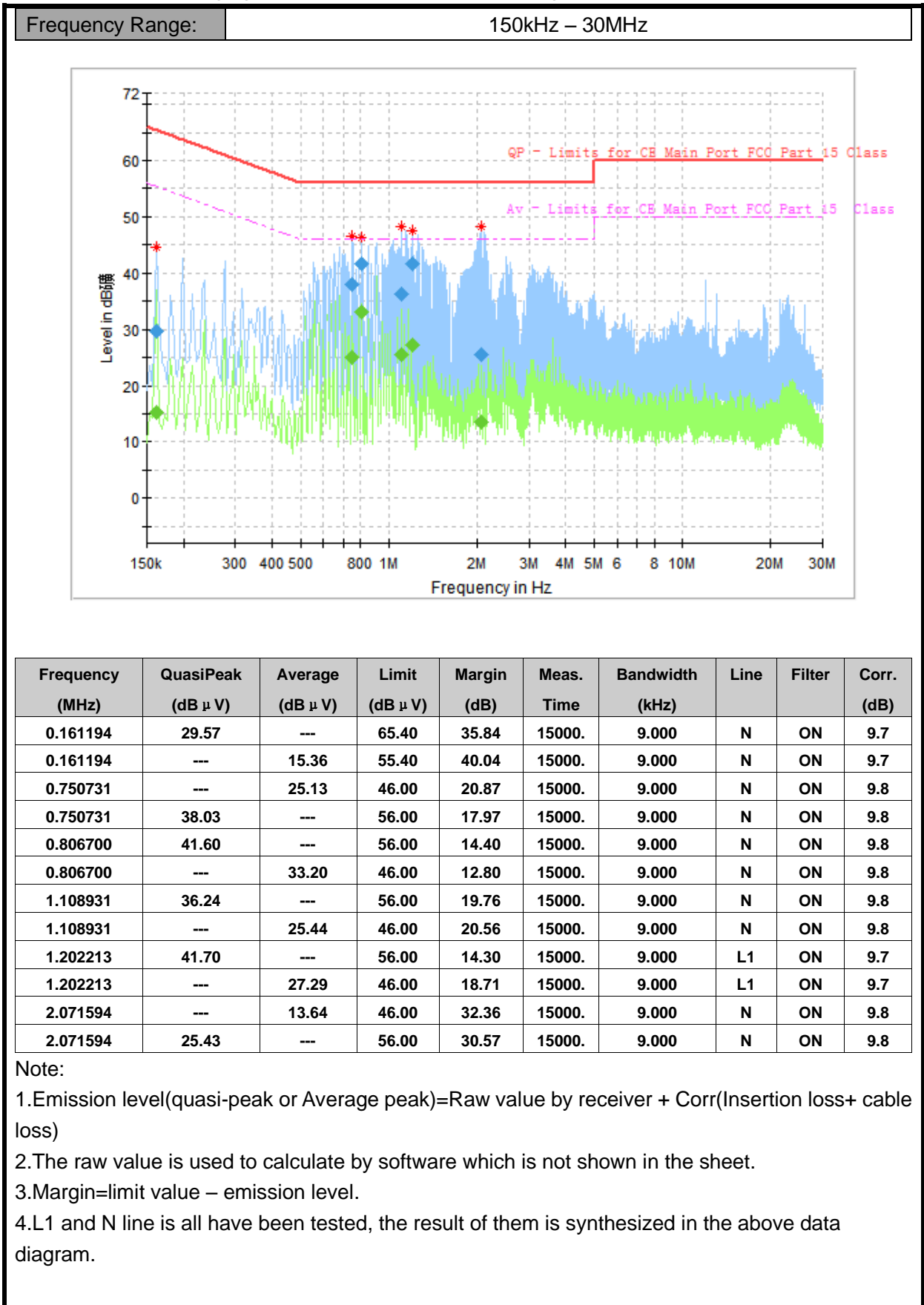

**Annex A Accreditation Certificate****Accredited Laboratory**

A2LA has accredited

**EAST CHINA INSTITUTE OF TELECOMMUNICATIONS***Shanghai, People's Republic of China*

for technical competence in the field of

**Electrical Testing**

This laboratory is accredited in accordance with the recognized International Standard ISO/IEC 17025:2017 General requirements for the competence of testing and calibration laboratories. This accreditation demonstrates technical competence for a defined scope and the operation of a laboratory quality management system (refer to joint ISO-ILAC-IAF Communiqué dated April 2017).

Presented this 6<sup>th</sup> day of May 2019.

Vice President, Accreditation Services  
For the Accreditation Council  
Certificate Number 3682.01  
Valid to February 28, 2021

*For the tests to which this accreditation applies, please refer to the laboratory's Electrical Scope of Accreditation.*

**\*\*\*\*\*END OF REPORT\*\*\*\*\***