



RF TEST REPORT

Applicant Mobiwire SAS

FCC ID QPN-ONEIDA

Product 4G Smart Feature Phone

Brand MobiWire

Model MobiWire Oneida, MobiWire Oneida
Lite, MBW Vodacom Vibe 4G

Report No. R1912A0712-R3

Issue Date December 31, 2019

TA Technology (Shanghai) Co., Ltd. tested the above equipment in accordance with the requirements in **FCC CFR47 Part 2 (2018)/ FCC CFR47 Part 27C (2018)**. The test results show that the equipment tested is capable of demonstrating compliance with the requirements as documented in this report.

Performed by: Peng Tao

Approved by: Kai Xu

TA Technology (Shanghai) Co., Ltd.

No.145, Jintang Rd, Tangzhen Industry Park, Pudong Shanghai, China

TEL: +86-021-50791141/2/3

FAX: +86-021-50791141/2/3-8000



TABLE OF CONTENT

1	Test Laboratory	4
1.1	Notes of the Test Report	4
1.2	Testing Location	4
2	General Description of Equipment under Test	5
2.1	Applicant and Manufacturer Information	5
2.2	General information	5
3	Applied Standards	7
4	Test Configuration	8
5	Test Case Results	9
5.1	RF Power Output	9
5.2	Radiates Spurious Emission	15
6	Main Test Instruments	19



Summary of Measurement Results

Number	Test Case	Clause in FCC rules	Verdict
1	RF power output	2.1046	PASS
2	Effective Radiated Power	27.50(h)(2)	Refer to the Original
3	Occupied Bandwidth	2.1049	Refer to the Original
4	Band Edge Compliance	27.53(m)	Refer to the Original
5	Peak-to-Average Power Ratio	27.50(d)/KDB971168 D01(5.7)	Refer to the Original
6	Frequency Stability	2.1055 / 27.54	Refer to the Original
7	Spurious Emissions at Antenna Terminals	2.1051 /27.53(m)	Refer to the Original
8	Radiates Spurious Emission	2.1053 /27.53(m)	PASS

Note: PASS: The EUT complies with the essential requirements in the standard.
FAIL: The EUT does not comply with the essential requirements in the standard.

Date of Testing: December 10, 2019~ December 14, 2019

MobiWire Oneida, MobiWire Oneida Lite, MBW Vodacom Vibe 4G (Report No.: R1912A0712-R3) is a variant model of MobiWire Oneida (Report No.: I18D00205-SRD05). Test values partial duplicated from Original for variant. There is only tested RF power output and Radiated Spurious Emission for variant in this report. The detailed product change description please refers to the *GM2809D Oneida Product Change Description 20191205*



1 Test Laboratory

1.1 Notes of the Test Report

This report shall not be reproduced in full or partial, without the written approval of **TA technology (shanghai) co., Ltd.** The results documented in this report apply only to the tested sample, under the conditions and modes of operation as described herein .Measurement Uncertainties were not taken into account and are published for informational purposes only. This report is written to support regulatory compliance of the applicable standards stated above.

1.2 Testing Location

Company: TA Technology (Shanghai) Co., Ltd.
Address: No.145, Jintang Rd, Tangzhen Industry Park, Pudong Shanghai, China
City: Shanghai
Post code: 201201
Country: P. R. China
Contact: Xu Kai
Telephone: +86-021-50791141/2/3
Fax: +86-021-50791141/2/3-8000
Website: <http://www.ta-shanghai.com>
E-mail: xukai@ta-shanghai.com

2 General Description of Equipment under Test

2.1 Applicant and Manufacturer Information

Applicant	Mobiwire SAS
Applicant address	79 avenue Francois Arago, 92000 NANTERRE France
Manufacturer	Mobiwire SAS
Manufacturer address	79 avenue Francois Arago, 92000 NANTERRE France

2.2 General information

EUT Description			
Model	MobiWire Oneida, MobiWire Oneida Lite, MBW Vodacom Vibe 4G		
IMEI	IMEI 1:352718110002129 IMEI 2:352718110002137		
Hardware Version	V04C		
Software Version	V01		
Power Supply	Battery/AC adapter		
Antenna Type	Internal Antenna		
Antenna Gain	-1.0dBi		
Test Mode(s)	LTE Band 7;		
Test Modulation	(LTE)QPSK 16QAM;		
LTE Category	4		
Rated Power Supply Voltage:	3.7V		
Extreme Voltage	Minimum: 3.6V Maximum: 4.2V		
Extreme Temperature	Lowest:-10°C Highest: +55°C		
Operating Frequency Range(s)	Mode	Tx (MHz)	Rx (MHz)
	LTE Band 7	2500 ~ 2570	2620 ~ 2690
EUT Accessory			
Adapter	Manufacturer: DongGuan Aohai Power Technology Co.,Ltd Model: A31A-050055U-US1		
Battery	Manufacturer: NINGBO VEKEN BATTERY CO.,LTD Model: 178150977		
Earphone 1	Manufacturer: jiu jiang JUWEI ELECTRONICS CO.,LTD Model: JWEP1062-M01R 1.0m, Shielded		
Earphone 2	Manufacturer: jiu jiang JUWEI ELECTRONICS CO.,LTD Model: JWEP0944-M01R 1.0m, Shielded		



Note: The information of the EUT is declared by the manufacturer.

2. There is more than one SIM, each one should be applied throughout the compliance test respectively, and however, only the worst case (SIM 1) will be recorded in this report.

Item	Configure 1	Configure 2	Configure 3	Configure 4
Software	the same	the same	the same	the same
Hardware	the same	the same	the same	the same
Frequency band	the same	the same	the same	the same
camera	with camera	with camera	without camera	without camera
SIM card slot	2*SIM card	2*SIM card	1*SIM card	1*SIM card
LCD	HLT LCD	SL LCD	HLT LCD	SL LCD
Other	The same	The same	The same	The same

Note: Customer declaration, Four configures is the same, except for camera , LCD and SIM card slot. There are more than one Configure, each one should be applied throughout the compliance test respectively, however, only the worst case (Configure 2) will be recorded in this report.



3 Applied Standards

According to the specifications of the manufacturer, it must comply with the requirements of the following standards:

Test standards:

FCC CFR47 Part 27C (2018)

ANSI C63.26 (2015)

Reference standard:

FCC CFR47 Part 2 (2018)

KDB 971168 D01 Power Meas License Digital Systems v03r01

4 Test Configuration

There is more than one SIM card slot, each one should be applied throughout the compliance test respectively, and however, only the worst case (SIM 1) will be recorded in this report

Radiated measurements are performed by rotating the EUT in three different orthogonal test planes. EUT stand-up position (Z axis), lie-down position (X, Y axis). Receiver antenna polarization (horizontal and vertical), the worst emission was found in position (Z axis, horizontal polarization) and the worst case was recorded.

All mode and data rates and positions and RB size and modulations were investigated.

Subsequently, only the worst case emissions are reported.

The following testing in LTE is set based on the maximum RF Output Power.

The following testing in different Bandwidth is set to detail in the following table:

Test modes are chosen to be reported as the worst case configuration below for LTE Band 7:

Test items	Modes	Bandwidth (MHz)						Modulation		RB			Test Channel			
		1.4	3	5	10	15	20	QPSK	16QAM	1	50%	100%	L	M	H	
RF power output	LTE 7	-	-	○	○	○	○	○	○	○	○	○	○	○	○	○
Radiates Spurious Emission	LTE 7	-	-	○	-	-	○	○	-	○	-	-	-	○	-	
Note	1. The mark "○" means that this configuration is chosen for testing. 2. The mark "-" means that this configuration is not testing.															

5 Test Case Results

5.1 RF Power Output

Ambient condition

Temperature	Relative humidity	Pressure
23°C ~25°C	45%~50%	101.5kPa

Methods of Measurement

During the process of the testing, The EUT is controlled by the Base Station Simulator to ensure max power transmission and proper modulation.

1. The testing follows FCC KDB 971168 D01 v03r01 Section 5.8 and ANSI C63.26 (2015).

- a) Connect the equipment as illustrated. Mount the equipment with the manufacturer specified antenna in a vertical orientation on a manufacturer specified mounting surface located on a non-conducting rotating platform of a RF anechoic chamber (preferred) or a standard radiation site.
- b) Key the transmitter, then rotate the EUT 360° azimuthally and record spectrum analyzer power level (LVL) measurements at angular increments that are sufficiently small to permit resolution of all peaks. If a standard radiation test site is used, raise and lower the test antenna to obtain a maximum reading at each angular increment. (Note: several batteries may be needed to offset the effect of battery voltage droop, which should not exceed 5% of the manufactured specified battery voltage during transmission).
- c) Replace the transmitter under test with a vertically polarized half-wave dipole (or an antenna whose gain is known relative to an ideal half-wave dipole). The center of the antenna should be at the same location as the center of the antenna under test.
- d) Connect the antenna to a signal generator with a known output power and record the path loss (in dB) as LOSS. If a standard radiation test site is used, raise and lower the test antenna to obtain a maximum reading. $LOSS = \text{Generator Output Power (dBm)} - \text{Analyzer reading (dBm)}$
- e) Determine the effective radiated output power at each angular position from the readings in steps b) and d) using the following equation: $ERP \text{ (dBm)} = \text{LVL (dBm)} + \text{LOSS (dB)}$
- f) The maximum ERP is the maximum value determined in the preceding step.
- g) When calculating ERP, in addition to knowing the antenna radiation and matching characteristics, it is necessary to know the loss values of all elements (e.g. transmission line attenuation, mismatches, filters, combiners) interposed between the point where transmitter output power is measured, and the point where power is applied to the antenna. ERP can then be calculated as follows:

$$EIRP \text{ (dBm)} = \text{Output Power (dBm)} - \text{Losses (dB)} + \text{Antenna Gain (dBi)}$$

where: dBd refers to gain relative to an ideal dipole.

$$EIRP \text{ (dBm)} = ERP \text{ (dBm)} + 2.15 \text{ (dB.)}$$

The RB allocation refers to section 5.1, using the maximum output power configuration.

Test Setup

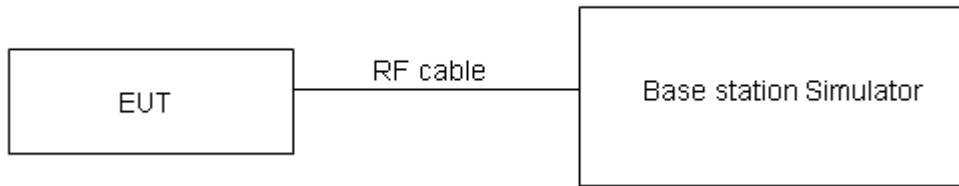

The loss between RF output port of the EUT and the input port of the tester has been taken into consideration.

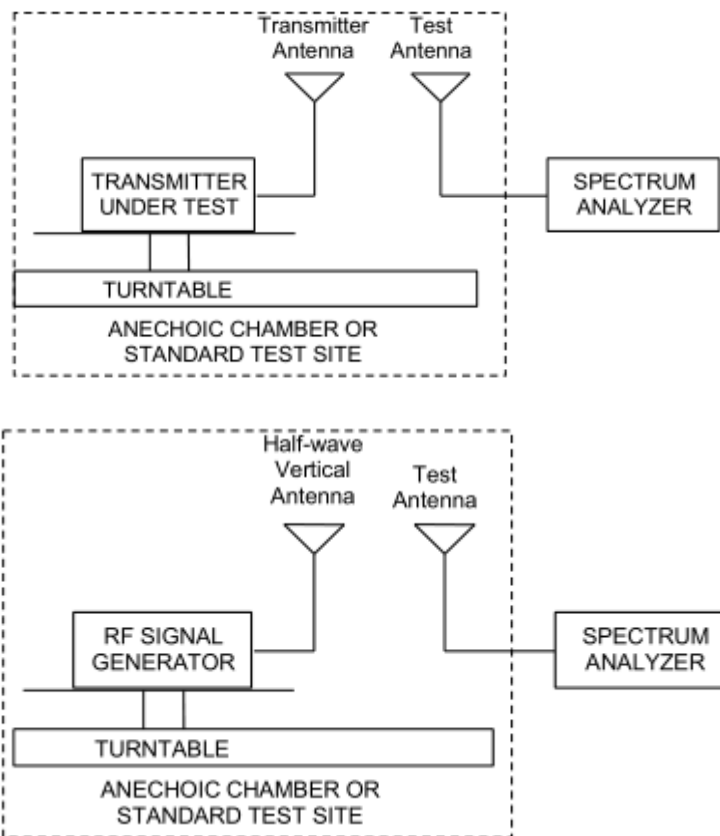

Note: Area side:2.4mX3.6m

The radiated emission was measured in the following position: EUT stand-up position (Z axis), lie-down position (X, Y axis). The worst emission was found in stand-up position (Z axis) and the worst case was recorded.

Limits

No specific RF power output requirements in part 2.1046.

Measurement Uncertainty

The assessed measurement uncertainty to ensure 95% confidence level for the normal distribution is with the coverage factor $k = 2$, $U=0.4$ dB for RF power output.

Test Results

BAND	Bandwidth	Modulation	Channel	RB Configuration	Conducted Power(dBm)	Verdict
Band7	5M	QPSK	20775	1RB#0	21.03	PASS
Band7	5M	QPSK	20775	1RB#13	21.49	PASS
Band7	5M	QPSK	20775	1RB#24	21.16	PASS
Band7	5M	QPSK	20775	12RB#0	20.29	PASS
Band7	5M	QPSK	20775	12RB#6	20.28	PASS
Band7	5M	QPSK	20775	12RB#13	20.34	PASS
Band7	5M	QPSK	20775	25RB#0	20.30	PASS
Band7	5M	QPSK	21100	1RB#0	21.19	PASS
Band7	5M	QPSK	21100	1RB#13	21.54	PASS
Band7	5M	QPSK	21100	1RB#24	20.94	PASS
Band7	5M	QPSK	21100	12RB#0	20.32	PASS
Band7	5M	QPSK	21100	12RB#6	20.38	PASS
Band7	5M	QPSK	21100	12RB#13	20.47	PASS
Band7	5M	QPSK	21100	25RB#0	20.26	PASS
Band7	5M	QPSK	21425	1RB#0	20.60	PASS
Band7	5M	QPSK	21425	1RB#13	21.15	PASS
Band7	5M	QPSK	21425	1RB#24	20.96	PASS
Band7	5M	QPSK	21425	12RB#0	20.03	PASS
Band7	5M	QPSK	21425	12RB#6	19.99	PASS
Band7	5M	QPSK	21425	12RB#13	19.92	PASS
Band7	5M	QPSK	21425	25RB#0	19.96	PASS
Band7	5M	16QAM	20775	1RB#0	19.82	PASS
Band7	5M	16QAM	20775	1RB#13	20.31	PASS
Band7	5M	16QAM	20775	1RB#24	19.90	PASS
Band7	5M	16QAM	20775	12RB#0	18.89	PASS
Band7	5M	16QAM	20775	12RB#6	18.96	PASS
Band7	5M	16QAM	20775	12RB#13	19.02	PASS
Band7	5M	16QAM	20775	25RB#0	19.07	PASS
Band7	5M	16QAM	21100	1RB#0	19.81	PASS
Band7	5M	16QAM	21100	1RB#13	20.28	PASS
Band7	5M	16QAM	21100	1RB#24	19.97	PASS
Band7	5M	16QAM	21100	12RB#0	18.94	PASS
Band7	5M	16QAM	21100	12RB#6	19.01	PASS
Band7	5M	16QAM	21100	12RB#13	19.01	PASS
Band7	5M	16QAM	21100	25RB#0	18.98	PASS
Band7	5M	16QAM	21425	1RB#0	20.19	PASS
Band7	5M	16QAM	21425	1RB#13	20.64	PASS
Band7	5M	16QAM	21425	1RB#24	20.36	PASS
Band7	5M	16QAM	21425	12RB#0	19.17	PASS
Band7	5M	16QAM	21425	12RB#6	19.12	PASS



Band7	5M	16QAM	21425	12RB#13	19.06	PASS
Band7	5M	16QAM	21425	25RB#0	19.09	PASS
Band7	10M	QPSK	20800	1RB#0	20.98	PASS
Band7	10M	QPSK	20800	1RB#25	21.43	PASS
Band7	10M	QPSK	20800	1RB#49	21.09	PASS
Band7	10M	QPSK	20800	25RB#0	20.22	PASS
Band7	10M	QPSK	20800	25RB#13	20.24	PASS
Band7	10M	QPSK	20800	25RB#25	20.27	PASS
Band7	10M	QPSK	20800	50RB#0	20.28	PASS
Band7	10M	QPSK	21100	1RB#0	21.06	PASS
Band7	10M	QPSK	21100	1RB#25	21.50	PASS
Band7	10M	QPSK	21100	1RB#49	20.86	PASS
Band7	10M	QPSK	21100	25RB#0	20.28	PASS
Band7	10M	QPSK	21100	25RB#13	20.34	PASS
Band7	10M	QPSK	21100	25RB#25	20.39	PASS
Band7	10M	QPSK	21100	50RB#0	20.18	PASS
Band7	10M	QPSK	21400	1RB#0	20.54	PASS
Band7	10M	QPSK	21400	1RB#25	21.09	PASS
Band7	10M	QPSK	21400	1RB#49	20.86	PASS
Band7	10M	QPSK	21400	25RB#0	19.97	PASS
Band7	10M	QPSK	21400	25RB#13	19.94	PASS
Band7	10M	QPSK	21400	25RB#25	19.93	PASS
Band7	10M	QPSK	21400	50RB#0	19.97	PASS
Band7	10M	16QAM	20800	1RB#0	19.79	PASS
Band7	10M	16QAM	20800	1RB#25	20.29	PASS
Band7	10M	16QAM	20800	1RB#49	19.88	PASS
Band7	10M	16QAM	20800	25RB#0	18.86	PASS
Band7	10M	16QAM	20800	25RB#13	18.93	PASS
Band7	10M	16QAM	20800	25RB#25	18.97	PASS
Band7	10M	16QAM	20800	50RB#0	19.05	PASS
Band7	10M	16QAM	21100	1RB#0	19.78	PASS
Band7	10M	16QAM	21100	1RB#25	20.23	PASS
Band7	10M	16QAM	21100	1RB#49	19.90	PASS
Band7	10M	16QAM	21100	25RB#0	18.91	PASS
Band7	10M	16QAM	21100	25RB#13	18.96	PASS
Band7	10M	16QAM	21100	25RB#25	19.01	PASS
Band7	10M	16QAM	21100	50RB#0	18.98	PASS
Band7	10M	16QAM	21400	1RB#0	20.14	PASS
Band7	10M	16QAM	21400	1RB#25	20.60	PASS
Band7	10M	16QAM	21400	1RB#49	20.32	PASS
Band7	10M	16QAM	21400	25RB#0	19.13	PASS
Band7	10M	16QAM	21400	25RB#13	19.06	PASS
Band7	10M	16QAM	21400	25RB#25	19.03	PASS



Band7	10M	16QAM	21400	50RB#0	19.07	PASS
Band7	15M	QPSK	20825	1RB#0	20.97	PASS
Band7	15M	QPSK	20825	1RB#38	21.41	PASS
Band7	15M	QPSK	20825	1RB#74	21.06	PASS
Band7	15M	QPSK	20825	36RB#0	20.20	PASS
Band7	15M	QPSK	20825	36RB#18	20.21	PASS
Band7	15M	QPSK	20825	36RB#39	20.24	PASS
Band7	15M	QPSK	20825	75RB#0	20.26	PASS
Band7	15M	QPSK	21100	1RB#0	21.02	PASS
Band7	15M	QPSK	21100	1RB#38	21.49	PASS
Band7	15M	QPSK	21100	1RB#74	20.81	PASS
Band7	15M	QPSK	21100	36RB#0	20.24	PASS
Band7	15M	QPSK	21100	36RB#18	20.29	PASS
Band7	15M	QPSK	21100	36RB#39	20.36	PASS
Band7	15M	QPSK	21100	75RB#0	20.14	PASS
Band7	15M	QPSK	21375	1RB#0	20.52	PASS
Band7	15M	QPSK	21375	1RB#38	21.06	PASS
Band7	15M	QPSK	21375	1RB#74	20.82	PASS
Band7	15M	QPSK	21375	36RB#0	19.94	PASS
Band7	15M	QPSK	21375	36RB#18	19.90	PASS
Band7	15M	QPSK	21375	36RB#39	19.89	PASS
Band7	15M	QPSK	21375	75RB#0	19.92	PASS
Band7	15M	16QAM	20825	1RB#0	19.74	PASS
Band7	15M	16QAM	20825	1RB#38	20.27	PASS
Band7	15M	16QAM	20825	1RB#74	19.85	PASS
Band7	15M	16QAM	20825	36RB#0	18.83	PASS
Band7	15M	16QAM	20825	36RB#18	18.90	PASS
Band7	15M	16QAM	20825	36RB#39	18.95	PASS
Band7	15M	16QAM	20825	75RB#0	19.02	PASS
Band7	15M	16QAM	21100	1RB#0	19.76	PASS
Band7	15M	16QAM	21100	1RB#38	20.20	PASS
Band7	15M	16QAM	21100	1RB#74	19.86	PASS
Band7	15M	16QAM	21100	36RB#0	18.89	PASS
Band7	15M	16QAM	21100	36RB#18	18.91	PASS
Band7	15M	16QAM	21100	36RB#39	18.97	PASS
Band7	15M	16QAM	21100	75RB#0	18.93	PASS
Band7	15M	16QAM	21375	1RB#0	20.12	PASS
Band7	15M	16QAM	21375	1RB#38	20.58	PASS
Band7	15M	16QAM	21375	1RB#74	20.29	PASS
Band7	15M	16QAM	21375	36RB#0	19.10	PASS
Band7	15M	16QAM	21375	36RB#18	19.02	PASS
Band7	15M	16QAM	21375	36RB#39	19.00	PASS
Band7	15M	16QAM	21375	75RB#0	19.03	PASS



Band7	20M	QPSK	20850	1RB#0	20.94	PASS
Band7	20M	QPSK	20850	1RB#50	21.40	PASS
Band7	20M	QPSK	20850	1RB#99	21.04	PASS
Band7	20M	QPSK	20850	50RB#0	20.17	PASS
Band7	20M	QPSK	20850	50RB#25	20.19	PASS
Band7	20M	QPSK	20850	50RB#50	20.21	PASS
Band7	20M	QPSK	20850	100RB#0	20.23	PASS
Band7	20M	QPSK	21100	1RB#0	20.98	PASS
Band7	20M	QPSK	21100	1RB#50	21.45	PASS
Band7	20M	QPSK	21100	1RB#99	20.80	PASS
Band7	20M	QPSK	21100	50RB#0	20.19	PASS
Band7	20M	QPSK	21100	50RB#25	20.25	PASS
Band7	20M	QPSK	21100	50RB#50	20.31	PASS
Band7	20M	QPSK	21100	100RB#0	20.09	PASS
Band7	20M	QPSK	21350	1RB#0	20.49	PASS
Band7	20M	QPSK	21350	1RB#50	21.04	PASS
Band7	20M	QPSK	21350	1RB#99	20.79	PASS
Band7	20M	QPSK	21350	50RB#0	19.90	PASS
Band7	20M	QPSK	21350	50RB#25	19.87	PASS
Band7	20M	QPSK	21350	50RB#50	19.85	PASS
Band7	20M	QPSK	21350	100RB#0	19.88	PASS
Band7	20M	16QAM	20850	1RB#0	19.72	PASS
Band7	20M	16QAM	20850	1RB#50	20.23	PASS
Band7	20M	16QAM	20850	1RB#99	19.83	PASS
Band7	20M	16QAM	20850	50RB#0	18.80	PASS
Band7	20M	16QAM	20850	50RB#25	18.87	PASS
Band7	20M	16QAM	20850	50RB#50	18.92	PASS
Band7	20M	16QAM	20850	100RB#0	19.00	PASS
Band7	20M	16QAM	21100	1RB#0	19.72	PASS
Band7	20M	16QAM	21100	1RB#50	20.18	PASS
Band7	20M	16QAM	21100	1RB#99	19.83	PASS
Band7	20M	16QAM	21100	50RB#0	18.85	PASS
Band7	20M	16QAM	21100	50RB#25	18.89	PASS
Band7	20M	16QAM	21100	50RB#50	18.92	PASS
Band7	20M	16QAM	21100	100RB#0	18.89	PASS
Band7	20M	16QAM	21350	1RB#0	20.07	PASS
Band7	20M	16QAM	21350	1RB#50	20.54	PASS
Band7	20M	16QAM	21350	1RB#99	20.27	PASS
Band7	20M	16QAM	21350	50RB#0	19.07	PASS
Band7	20M	16QAM	21350	50RB#25	18.99	PASS
Band7	20M	16QAM	21350	50RB#50	18.96	PASS
Band7	20M	16QAM	21350	100RB#0	19.00	PASS

5.2 Radiates Spurious Emission

Ambient condition

Temperature	Relative humidity	Pressure
23°C ~25°C	45%~50%	101.5kPa

Method of Measurement

1. The testing follows FCC KDB 971168 D01 v03r01 Section 5.8 and ANSI C63.26 (2015).
2. Below 1GHz: The EUT is placed on a turntable 0.8 meters above the ground in the chamber, 3 meter away from the antenna. The maximal emission value is acquired by adjusting the antenna height, polarisation and turntable azimuth. Normally, the height range of antenna is 1 m to 4 m, the azimuth range of turntable is 0° to 360°, and the receive antenna has two polarizations Vertical (V) and Horizontal (H). Above 1GHz: (Note: the FCC's permission to use 1.5m as an alternative per TCBC Conf call of Dec. 2, 2014.) The EUT is placed on a turntable 1.5 meters above the ground in the chamber, 3 meter away from the antenna. The maximal emission value is acquired by adjusting the antenna height, polarisation and turntable azimuth. Normally, the height range of antenna is 1 m to 4 m, the azimuth range of turntable is 0° to 360°, and the receive antenna has two polarizations Vertical (V) and Horizontal (H).
3. A loop antenna, A log-periodic antenna or horn antenna shall be substituted in place of the EUT. The log-periodic antenna will be driven by a signal generator and the level will be adjusted till the same power value on the spectrum analyzer or receiver. The level of the spurious emissions can be calculated through the level of the signal generator, cable loss, the gain of the substitution antenna and the reading of the spectrum analyzer or receiver.
4. The EUT is then put into continuously transmitting mode at its maximum power level during the test. Set Test Receiver or Spectrum RBW=200Hz,VBW=600Hz for 9kHz150kHz , RBW=10kHz, VBW=30kHz 150kHz-30MHz ,RBW=100kHz,VBW=300kHz for 30MHz to 1GHz and RBW=1MHz, VBW=3MHz for above 1GHz And the maximum value of the receiver should be recorded as (Pr).
5. The EUT shall be replaced by a substitution antenna. In the chamber, an substitution antenna for the frequency band of interest is placed at the reference point of the chamber. An RF Signal source for the frequency band of interest is connected to the substitution antenna with a cable that has been constructed to not interfere with the radiation pattern of the antenna. A power (PMea) is applied to the input of the substitution antenna, and adjust the level of the signal generator output until the value of the receiver reach the previously recorded (Pr). The power of signal source (PMea) is recorded. The test should be performed by rotating the test item and adjusting the receiving antenna polarization.
6. A amplifier should be connected to the Signal Source output port. And the cable should be connect between the Amplifier and the Substitution Antenna. The cable loss (Pcl) ,the Substitution Antenna Gain (Ga) and the Amplifier Gain (PAg) should be recorded after test.
7. The measurement results are obtained as described below:
 $Power(EIRP)=PMea- PAg - Pcl + Ga$
 The measurement results are amend as described below:
 $Power(EIRP)=PMea- Pcl + Ga$
8. This value is EIRP since the measurement is calibrated using an antenna of known gain (2.15 dBi) and known input power. ERP can be calculated from EIRP by subtracting the gain of the dipole, ERP

= EIRP-2.15dBi.

The modulation mode and RB allocation refer to section 5.1, using the maximum output power configuration.

Test setup

9KHz ~ 30MHz

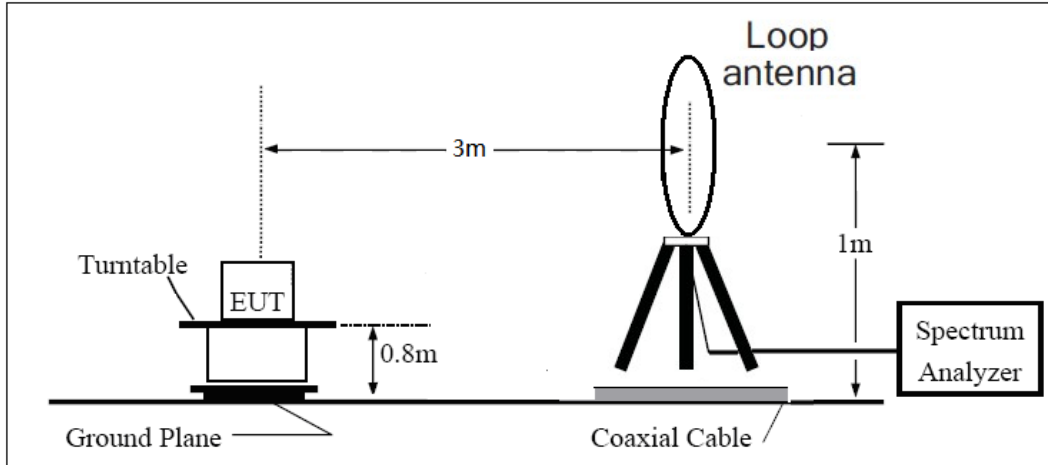

30MHz ~ 1GHz

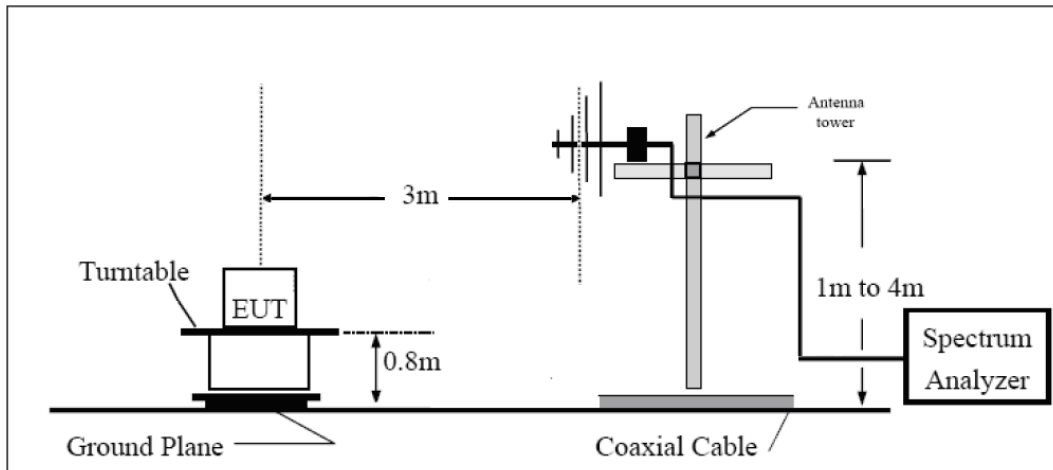

Above 1GHz

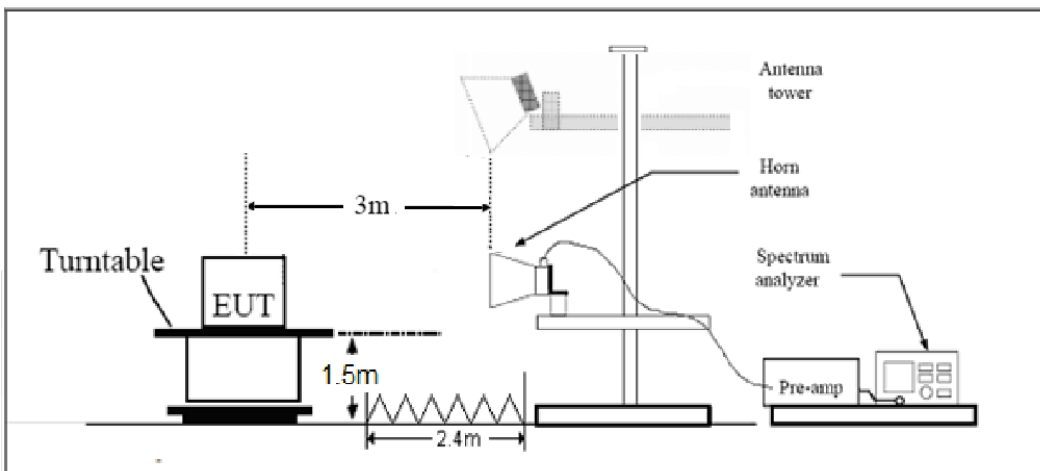

Note: Area side:2.4mX3.6m

**Limits**

LTE -7 Rule Part 27.53(m) $55 + 10 \log (P)$ dB on all frequencies more than X megahertz from the channel edge, where X is the greater of 6 megahertz or the actual emission bandwidth as defined in paragraph (m)(4) of this section.

Part 27.53(m) Limit	-25 dBm
---------------------	---------

Measurement Uncertainty

The assessed measurement uncertainty to ensure 95% confidence level for the normal distribution is with the coverage factor $k = \pm 1.96$, $U = \pm 3.55$ dB.

Test Result

Sweep the whole frequency band through the range from 9kHz to the 10th harmonic of the carrier, the emissions below the noise floor will not be recorded in the report.

LTE Band 7 QPSK 5MHz CH-Middle, RB 1

Harmonic	Frequency (MHz)	SG (dBm)	Cable Loss (dB)	Gain (dBi)	Antenna Polarization	EIRP Level (dBm)	Limit (dBm)	Margin (dB)	Azimuth (deg)
2	5065.8	-45.21	2.00	9.15	Horizontal	-38.06	-25.00	13.06	45
3	7598.6	-47.62	2.50	11.35	Horizontal	-38.77	-25.00	13.77	135
4	10130.6	-50.18	4.20	12.05	Horizontal	-42.33	-25.00	17.33	45
5	12675.0	-50.64	5.20	12.85	Horizontal	-42.99	-25.00	17.99	225
6	15210.0	-52.08	5.50	14.23	Horizontal	-43.35	-25.00	18.35	90
7	17745.0	-47.82	5.70	14.15	Horizontal	-39.37	-25.00	14.37	45
8	20280.0	--	--	--	--	--	--	--	--
9	22815.0	--	--	--	--	--	--	--	--
10	25350.0	--	--	--	--	--	--	--	--

Note: 1.The other Spurious RF Radiated emissions level is no more than noise floor.
2. The worst emission was found in the antenna is Horizontal position.

LTE Band 7 QPSK 20MHz CH-Middle, RB 1

Harmonic	Frequency (MHz)	SG (dBm)	Cable Loss (dB)	Gain (dBi)	Antenna Polarization	EIRP Level (dBm)	Limit (dBm)	Margin (dB)	Azimuth (deg)
2	5052.4	-47.04	2.00	10.15	Horizontal	-38.89	-25.00	13.89	45
3	7605.0	-47.88	2.50	11.35	Horizontal	-39.03	-25.00	14.03	315
4	10140.0	-50.93	4.20	12.05	Horizontal	-43.08	-25.00	18.08	225
5	12675.0	-52.82	5.20	14.85	Horizontal	-43.17	-25.00	18.17	45
6	15210.0	-52.39	5.50	13.23	Horizontal	-44.66	-25.00	19.66	315
7	17745.0	-46.24	5.70	12.15	Horizontal	-39.79	-25.00	14.79	45
8	20280.0	--	--	--	--	--	--	--	--
9	22815.0	--	--	--	--	--	--	--	--
10	25350.0	--	--	--	--	--	--	--	--

Note: 1.The other Spurious RF Radiated emissions level is no more than noise floor.
2. The worst emission was found in the antenna is Horizontal position.

6 Main Test Instruments

Name	Manufacturer	Type	Serial Number	Calibration Date	Expiration Date
Base Station Simulator	R&S	CMW500	113824	2019-05-19	2020-05-18
Power Splitter	Hua Xiang	SHX-GF2-2-13	10120101	/	/
Spectrum Analyzer	Key sight	N9010A	MY50210259	2019-05-19	2020-05-18
Signal Analyzer	R&S	FSV30	100815	2018-12-16	2019-12-15
Loop Antenna	SCHWARZBECK	FMZB1519	1519-047	2017-09-26	2020-09-25
Trilog Antenna	SCHWARZBECK	VUBL 9163	9163-201	2017-11-18	2020-11-17
Horn Antenna	R&S	HF907	100126	2018-07-07	2020-07-06
Horn Antenna	ETS-Lindgren	3160-09	00102643	2018-06-20	2020-06-19
Signal generator	R&S	SMB 100A	102594	2019-05-19	2020-05-18
Climatic Chamber	ESPEC	SU-242	93000506	2017-12-17	2020-12-16
Preamplifier	R&S	SCU18	102327	2019-05-19	2020-05-18
MOB COMMS DC SUPPLY	Keysight	66319D	MY43004105	2019-05-19	2020-05-18
RF Cable	Agilent	SMA 15cm	0001	2019-06-14	2019-12-13
RF Cable	Agilent	SMA 15cm	0001	2019-12-13	2020-06-12
Software	R&S	EMC32	9.26.0	/	/

*****END OF REPORT *****