



TEST REPORT

No. I19D00009-EMC01

For

Client : Mobewire SAS

Production: 4G Smart Feature Phone

Model Name : MobiWire Oneida

Brand Name: MobiWire

FCC ID: QPN-ONEIDA

Hardware Version: V04

Software Version: VDF_ONEIDA_SS_O_L_C_V01.0_2018

0919.MP_FCC

Issued date: 2019-03-05

NOTE

1. The test results in this test report relate only to the devices specified in this report.
2. This report shall not be reproduced except in full without the written approval of East China Institute of Telecommunications
3. The measurement uncertainty is not taken into account when deciding conformity, and the results of measurement (or the average of measurement results) are directly used as the criterion for the stating conformity.

Test Laboratory:

East China Institute of Telecommunications

Add: 7-8F, G Area, No.668, Beijing East Road, Huangpu District, Shanghai, P. R. China

Tel: +862163843300

FAX: +862163843301

E-Mail: welcome@ecit.org.cn

Revision Version

| Report Number | Revision | Date | Memo |
|-----------------|----------|------------|---------------------------------|
| I19D00009-EMC01 | 00 | 2019-03-05 | Initial creation of test report |

CONTENTS

| | |
|--|----|
| 1. TEST LABORATORY | 6 |
| 1.1. TESTING LOCATION | 6 |
| 1.2. TESTING ENVIRONMENT | 6 |
| 1.3. PROJECT DATA..... | 6 |
| 1.4. SIGNATURE..... | 6 |
| 2. CLIENT INFORMATION | 7 |
| 2.1. APPLICANT INFORMATION..... | 7 |
| 2.2. MANUFACTURER INFORMATION..... | 7 |
| 3. EQUIPMENT UNDER TEST (EUT) AND ANCILLARY EQUIPMENT (AE) | 8 |
| 3.1. ABOUT EUT..... | 8 |
| 3.2. INTERNAL IDENTIFICATION OF EUT USED DURING THE TEST | 8 |
| 3.3. INTERNAL IDENTIFICATION OF AE USED DURING THE TEST | 8 |
| 4. REFERENCE DOCUMENTS..... | 9 |
| 4.1 REFERENCE DOCUMENTS FOR TESTING..... | 9 |
| 5. TEST RESULTS..... | 10 |
| 5.1 SUMMARY OF TEST RESULTS | 10 |
| 5.2 STATEMENTS..... | 10 |
| 6. TEST EQUIPMENT UTILIZED | 11 |
| 6.1 RADIATED EMISSION EQUIPMENT LIST | 11 |
| 6.1 AC CONDUCTED EMISSION EQUIPMENT LIST | 11 |
| 7. SYSTEM CONFIGURATION DURING TEST..... | 12 |
| 7.1 TEST MODE..... | 12 |
| 7.2 CONNECTION DIAGRAM OF TEST SYSTEM..... | 13 |
| 8. MEASUREMENT RESULTS..... | 14 |
| 8.1 RADIATED EMISSION 30MHZ-18GHZ..... | 14 |

8.2 AC CONDUCTED EMISSION..... 24

1. Test Laboratory

1.1. Testing Location

Company Name: ECIT Shanghai, East China Institute of Telecommunications
Address: 7F, G Area, No. 668, Beijing East Road, Huangpu District, Shanghai,
P. R. China
Postal Code: 200001
Telephone: 86-21-63843300
Fax: 86-21-63843301
FCC registration No: 958356

1.2. Testing Environment

Normal Temperature: 15-35°C
Relative Humidity: 30-60%RH

1.3. Project data

Project Leader: Yu Anlu
Testing Start Date: 2019-03-04
Testing End Date: 2019-03-05

1.4. Signature

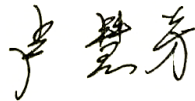

Lu Huifang
(Prepared this test report)



You Jinjun
(Reviewed this test report)

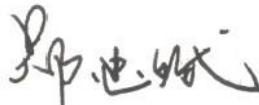

Zheng Zhongbin
(Approved this test report)

2. Client Information

2.1. Applicant Information

Company Name: Mobiwire SAS
Address : 79 AVENUE FRANCOIS ARAGO 92017 NANTERRE CEDEX
 France.
Telephone: +86 574 59555707
Post: /

2.2. Manufacturer Information

Company Name: Mobiwire SAS
Address : 79 AVENUE FRANCOIS ARAGO 92017 NANTERRE CEDEX
 France.
Telephone: +86 574 59555707
Post: /

3. Equipment under Test (EUT) and Ancillary Equipment (AE)

3.1. About EUT

| | |
|-----------------------------------|-----------------------------------|
| EUT Description | 4G Smart Feature Phone |
| Model name | MobiWire Oneida |
| GSM Frequency Band | GSM850/GSM1900/GSM900/GSM1800 |
| WCDMA Frequency Band | Band I /Band II /Band V /BandVIII |
| LTE Frequency Band | LTE 1/3/7/20 |
| Additional Communication Function | BT4.2;WiFi 802.11b,g,n;GPS; |

3.2. Internal Identification of EUT used during the test

| EUT ID* | SN or IMEI | HW Version | SW Version | Date of receipt |
|------------------------|-------------------------------------|------------|---|-----------------|
| N02 | 352548100000647/ 352548100000654 | V04 | VDF_ONEIDA_SS_O_L _C_V01.0_20180919.M P_FCC | 2019.03.04 |
| N05 (Single SIM) | 352548100004045 | V04 | VDF_ONEIDA_SS_O_L _C_V01.0_20180919.M P_FCC | 2019.03.04 |
| N06(Without Camera) | 352548100004995 | V04 | VDF_ONEIDA_SS_O_L _C_V01.0_20180919.M P_FCC | 2019.03.04 |

*EUT ID: is used to identify the test sample in the lab internally.

3.3. Internal Identification of AE used during the test

| AE ID* | Description | Model | SN |
|--------|----------------------|------------------|------------------------------|
| AA01 | Earphone | NA | NA |
| CA01 | Adapter | A31A-050055U-US1 | NA |
| AE1 | Desktop PC | OptiPlex 790 DT | X8RP1 A01 APCC |
| AE2 | Notebook PC | DELL E5250 | 7HXWF72 |
| AE3 | LAN Cable | NA | NA |
| AE4 | VGA Cable | NA | NA |
| AE5 | RS232 Cable | NA | NA |
| AE6 | Keyboard | KB212-B | CN-0Y88XT-65890-12I-005Q-A00 |
| AE7 | Mouse | MS111-P | CN-011D3V-71581-19J-1A64 |
| AE8 | Earphone | NA | NA |
| AE9 | Monitor | Dell E1709Wc | NA |
| AE10 | USB Cable | NA | NA |
| AE11 | SanDisk Ultra32GB | microSDHC UHS-I | NA |

*AE ID: is used to identify the test sample in the lab internally.

4. Reference Documents

4.1 Reference Documents for testing

The following documents listed in this section are referred for testing.

| Reference | Title | Version |
|---------------------------|---|-----------------|
| FCC Part 15, Subpart B | Radio frequency devices | 10-1-17 Edition |
| ANSI C63.4 | Method of Measurement of Radio-Noise Emissions from Low-Voltage Electrical and Electronic Equipment in the Range of 9 kHz to 40 GHz | 2014 |

5. Test Results

5.1 Summary of Test Results

| Items | Test List | Clause in FCC rules | Verdict |
|-------|-----------------------|---------------------|---------|
| 1 | Radiated Emission | 15.109(a) | Pass |
| 2 | AC Conducted Emission | 15.107(a) | Pass |

5.2 Statements

The MobiWire Oneida supporting GSM/WCDMA/LTE/BT/WLAN/GPS.etc, manufactured by Mobiwire SAS is a variant product for testing. ECIT only performed test cases which identified with Pass/Fail/Inc result in section 5.1.

ECIT has verified that the compliance of the tested device specified in section 3 of this test report is successfully evaluated according to the procedure and test methods as defined in type certification requirement listed in section 4 of this test report.

Note: This project is a variant project of I18D00205-EMC01 original report, testing the worst mode of the original report, and referring to the original report for other information

6. Test Equipment Utilized

6.1 Radiated Emission Equipment list

| No. | Name | Type | Series Number | Producer | Cal. Date | Cal. interval |
|-----|-------------------------------|-------------|---------------|-------------|------------|---------------|
| 1 | Universal Radio Communication | CMU200 | 123126 | R&S | 2018-05-11 | 1 Year |
| 2 | Test Receiver | ESU40 | 100307 | R&S | 2018-05-11 | 1 Year |
| 3 | Trilog Antenna | VULB9163 | VULB9163-515 | Schwarzbeck | 2017-02-25 | 3 Year |
| 4 | Double Ridged Guide | ETS-3117 | 00135885 | ETS | 2017-01-11 | 3 Year |
| 5 | EMI Test Software | EMC32 V9.15 | NA | R&S | NA | NA |

6.1 AC Conducted Emission Equipment list

| No. | Name | Type | Series Number | Producer | Cal. Date | Cal. interval |
|-----|-------------------|-----------------|---------------|----------|------------|---------------|
| 1 | Universal Radio | CMU200 | 123123 | R&S | 2018-05-11 | 1 Year |
| 2 | Test Receiver | ESCI | 101235 | R&S | 2018-05-11 | 1 Year |
| 3 | 2-Line V-Network | ENV216 | 101380 | R&S | 2018-05-11 | 1 Year |
| 4 | EMI Test Software | EMC32 V10.35.02 | NA | R&S | NA | NA |

7. System Configuration during Test

7.1 Test Mode

| Test Item | Function Type |
|---|---|
| AC Conducted Emission | Mode 2: Adapter charging <Figure 2>(N02) |
| | Mode 2: Adapter charging <Figure 2>(N05) |
| | Mode 2: Adapter charging <Figure 2>(N06) |
| Radiated Emission | Mode 1: USB cable (Data Link with PC) <Figure 1>(N02) |
| | Mode 2: Adapter charging <Figure 2>(N02) |
| | Mode 1: USB cable (Data Link with PC) <Figure 1>(N05) |
| | Mode 2: Adapter charging <Figure 2>(N05) |
| | Mode 1: USB cable (Data Link with PC) <Figure 1>(N06) |
| | Mode 2: Adapter charging <Figure 2>(N06) |
| Remark: 1.All test modes are performed, only the worst cases test data are recorded in this report. 2.Data Link with PC means data application transferred mode between EUT and PC. | |

7.2 Connection Diagram of Test System

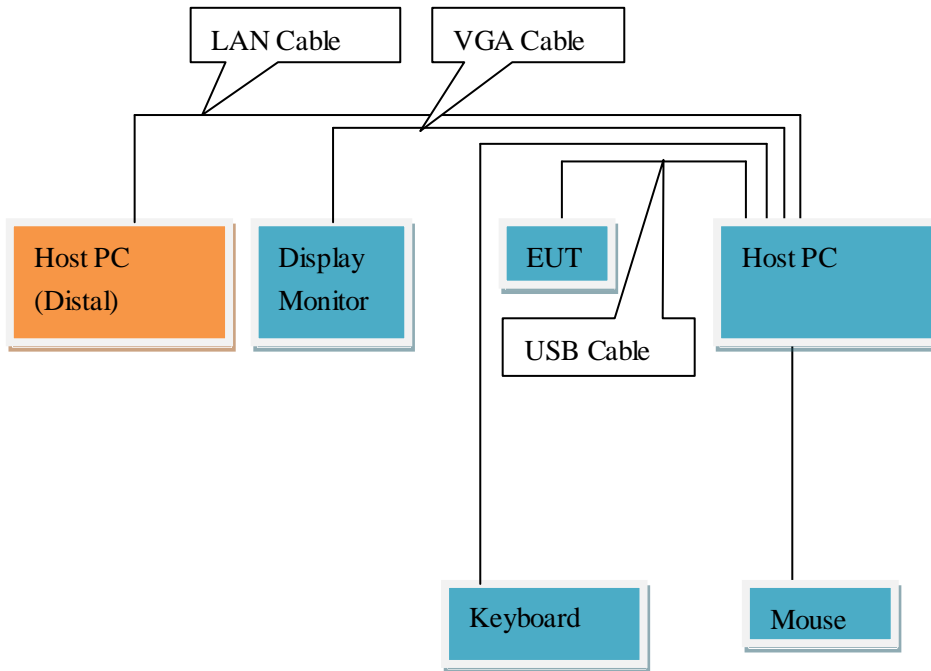

<Figure 1>



<Figure 2>

8. Measurement Results

Only the worst test result was shown in this report.

8.1 Radiated Emission 30MHz-18GHz

Method of Measurement

For 30MHz -1000MHz, the EUT was placed on the top of a rotating 0.8m table above the ground at a semi-anechoic chamber. The distance between the EUT and the received antenna was 3 meters. The table was rotated 360 degree and the received antenna mounted on a variable-height antenna tower was varied from 1m to 4m to find the maximum value of the field strength. Both horizontal and vertical polarizations of the antenna were set during the measurement. Tested in accordance with the procedures of ANSI C63.4-2014, section 8.3.

For 1000MHz -18000MHz, The maximal emission value was acquired by adjusting the antenna height, The table was rotated 360 degree to determine the maximum value of the field strength. Both horizontal and vertical polarizations of the antenna were set during the measurement.

Limits for Radiated Emission at a measuring distance of 3m

| Frequency Range (MHz) | Quasi-Peak (dBuV/m) |
|-----------------------|---------------------|
| 30-88 | 40 |
| 88-216 | 43.5 |
| 216-960 | 46 |
| Above 960 | 54 |

| Frequency Range (MHz) | Peak (dBuV/m) | Average (dBuV/m) |
|-----------------------|---------------|------------------|
| Above 1000 | 74 | 54 |

Test conditions

| Frequency Range (MHz) | RBW/VBW | Sweep Time (s) |
|-----------------------|---------------|----------------|
| 30-1000 | 120kHz/300kHz | Auto |
| 1000-18000 | 1MHz/3MHz | Auto |

Uncertainty Measurement

The measurement uncertainty (30MHz-1000MHz) is 4.98 dB (k=2).

The measurement uncertainty (1000MHz-18000MHz) is 5.06 dB (k=2).

Test Results

Mode 1: USB cable (Data Link with PC)(N02)

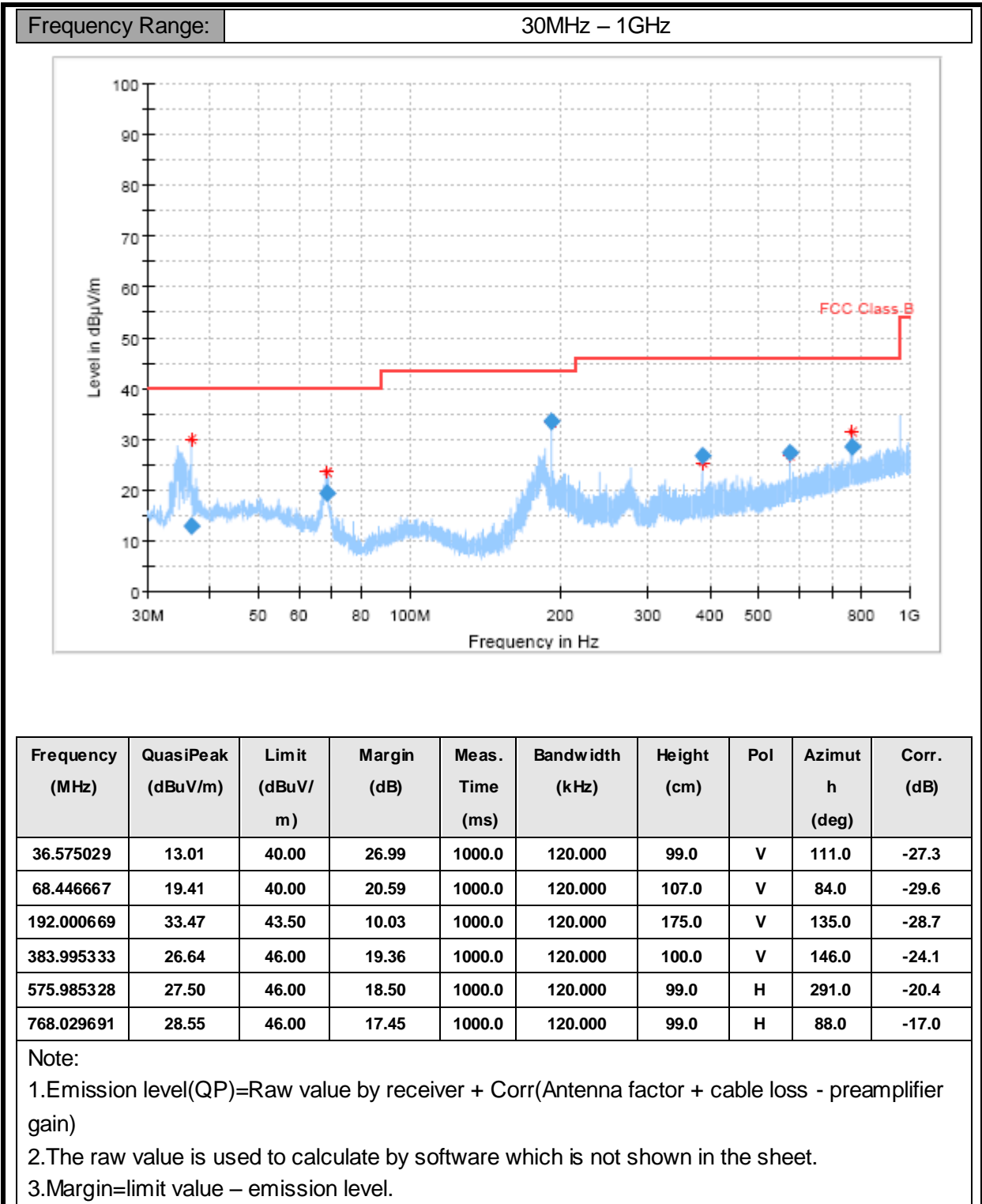

Mode 2: Adapter charging(N02)

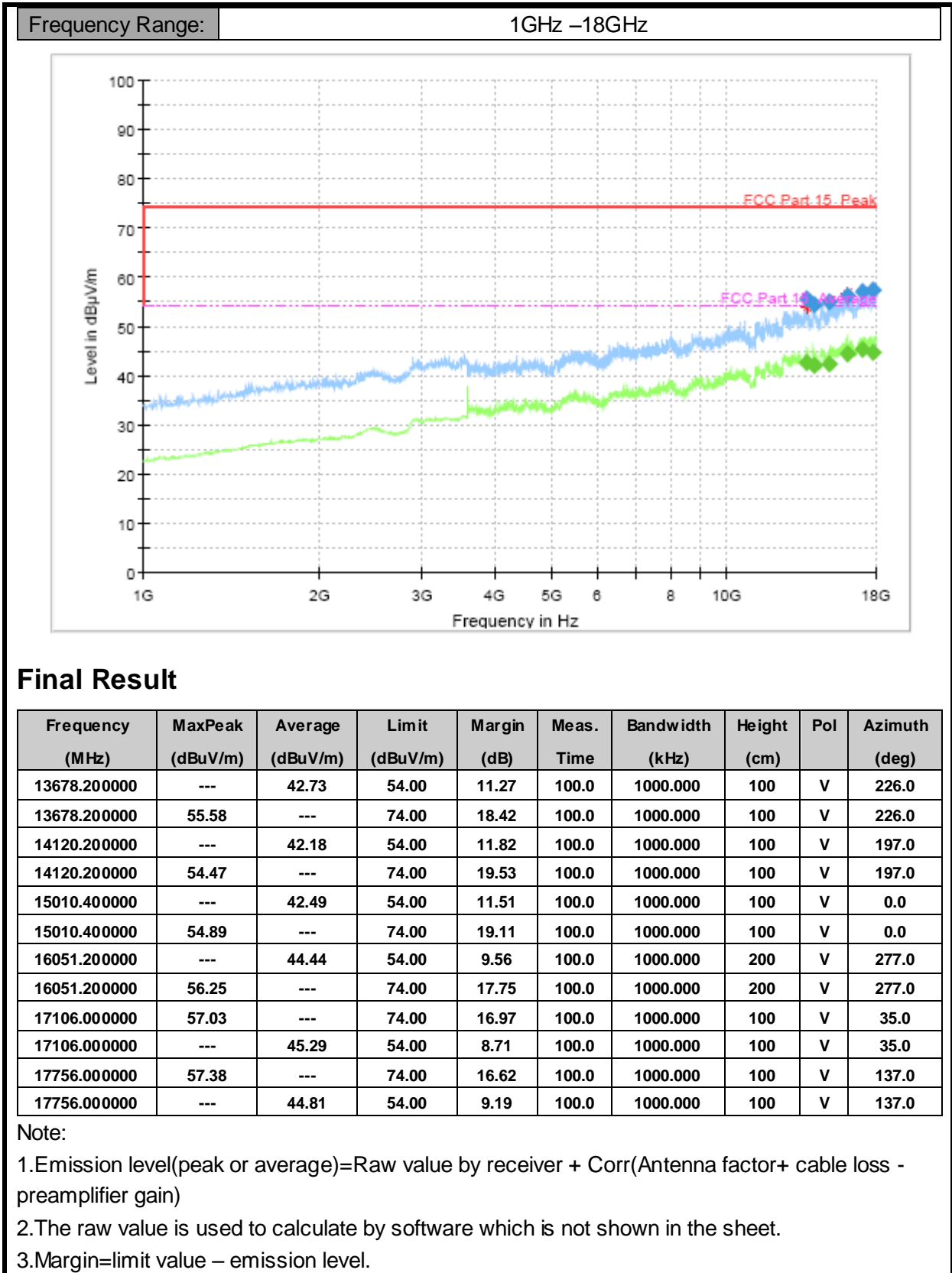

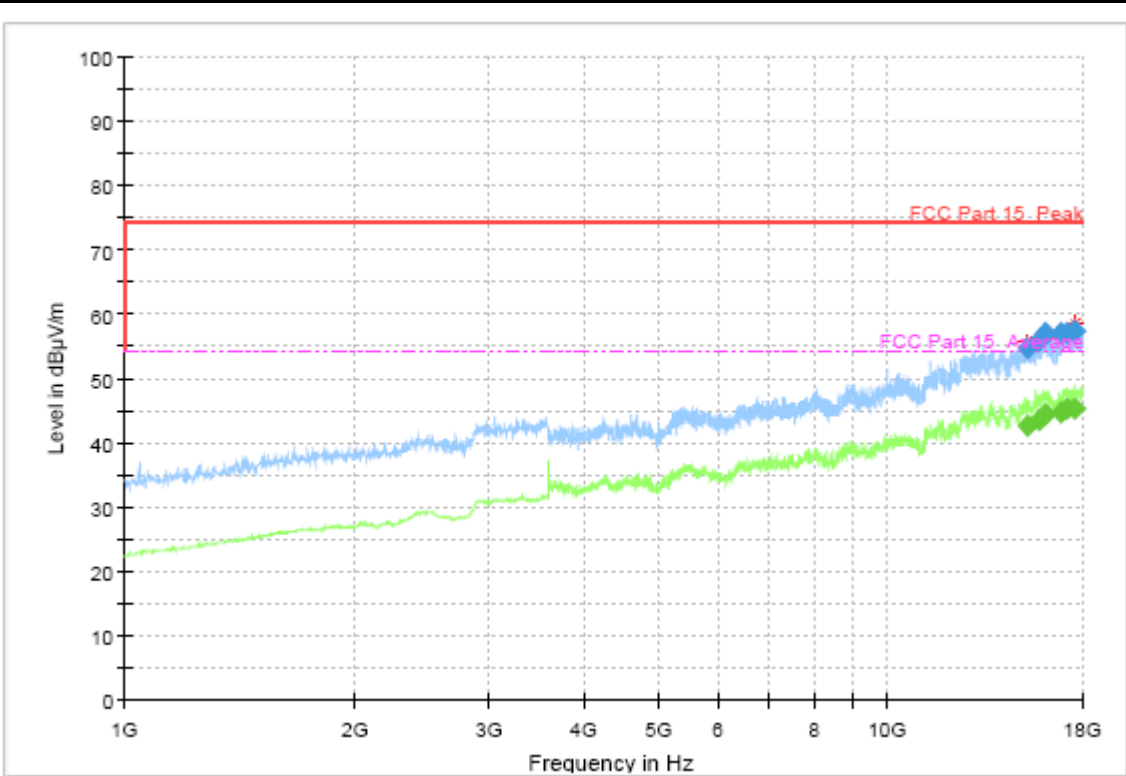

Final Result

| Frequency (MHz) | MaxPeak (dBuV/m) | Average (dBuV/m) | Limit (dBuV/m) | Margin (dB) | Meas. Time | Bandwidth (kHz) | Height (cm) | PoI | Azimuth (deg) |
|-----------------|------------------|------------------|----------------|-------------|------------|-----------------|-------------|-----|---------------|
| 15255.200000 | --- | 42.69 | 54.00 | 11.31 | 100.0 | 1000.000 | 100 | H | 96.0 |
| 15255.200000 | 54.85 | --- | 74.00 | 19.15 | 100.0 | 1000.000 | 100 | H | 96.0 |
| 15759.200000 | 55.98 | --- | 74.00 | 18.02 | 100.0 | 1000.000 | 100 | H | 201.0 |
| 15759.200000 | --- | 43.62 | 54.00 | 10.38 | 100.0 | 1000.000 | 100 | H | 201.0 |
| 16069.200000 | 56.96 | --- | 74.00 | 17.04 | 100.0 | 1000.000 | 100 | H | 170.0 |
| 16069.200000 | --- | 44.37 | 54.00 | 9.63 | 100.0 | 1000.000 | 100 | H | 170.0 |
| 16827.600000 | 57.12 | --- | 74.00 | 16.88 | 100.0 | 1000.000 | 100 | H | 249.0 |
| 16827.600000 | --- | 44.70 | 54.00 | 9.30 | 100.0 | 1000.000 | 100 | H | 249.0 |
| 17123.000000 | 57.00 | --- | 74.00 | 17.00 | 100.0 | 1000.000 | 100 | H | 238.0 |
| 17123.000000 | --- | 45.16 | 54.00 | 8.84 | 100.0 | 1000.000 | 100 | H | 238.0 |
| 17615.600000 | --- | 45.28 | 54.00 | 8.72 | 100.0 | 1000.000 | 200 | H | 291.0 |
| 17615.600000 | 57.27 | --- | 74.00 | 16.73 | 100.0 | 1000.000 | 200 | H | 291.0 |

Note:

1. Emission level (peak or average) = Raw value by receiver + Corr (Antenna factor + cable loss - preamplifier gain)
2. The raw value is used to calculate by software which is not shown in the sheet.
3. Margin = limit value - emission level.

Mode 1: USB cable (Data Link with PC)(N05)

Frequency Range: 30MHz – 1GHz

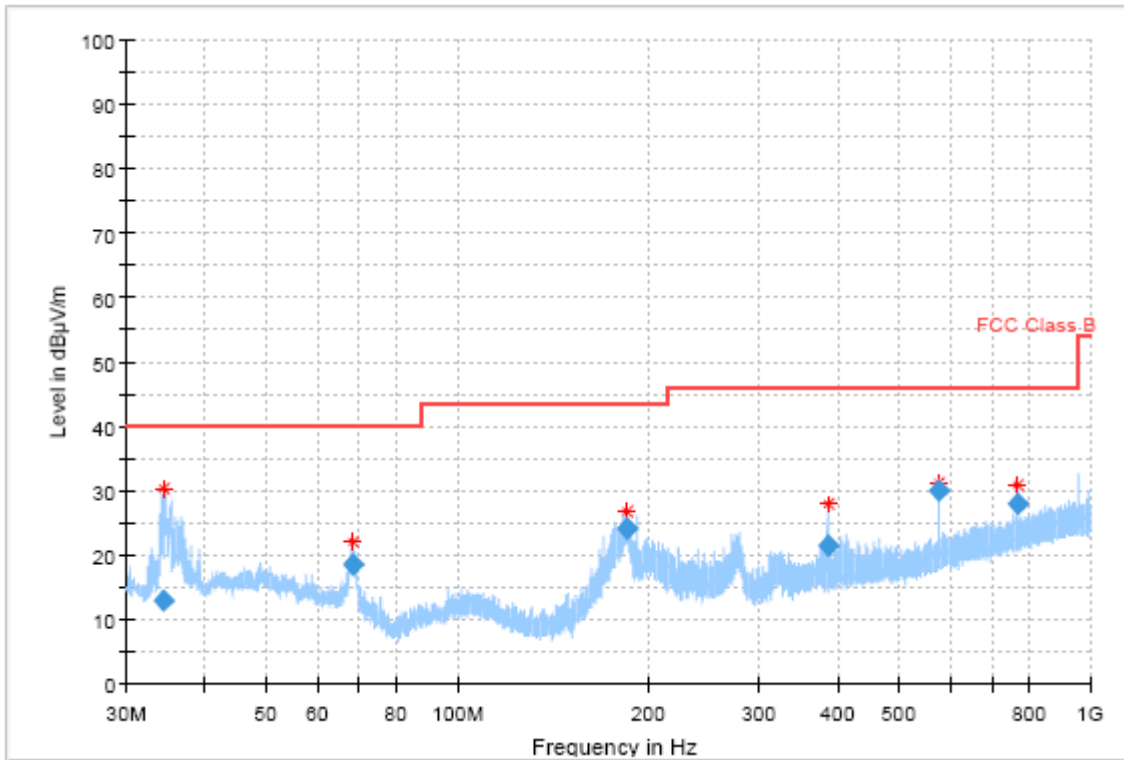

| Frequency (MHz) | QuasiPeak (dBuV/m) | Limit (dBuV/m) | Margin (dB) | Meas. Time (ms) | Bandwidth (kHz) | Height (cm) | PoI | Azimuth (deg) | Corr. (dB) |
|-----------------|--------------------|----------------|-------------|-----------------|-----------------|-------------|-----|---------------|------------|
| 34.416200 | 13.00 | 40.00 | 27.00 | 1000.0 | 120.000 | 100.0 | V | 117.0 | -27.7 |
| 68.491499 | 18.47 | 40.00 | 21.53 | 1000.0 | 120.000 | 99.0 | V | 154.0 | -29.6 |
| 185.347667 | 24.08 | 43.50 | 19.42 | 1000.0 | 120.000 | 175.0 | V | 145.0 | -29.0 |
| 384.048605 | 21.34 | 46.00 | 24.66 | 1000.0 | 120.000 | 105.0 | V | 160.0 | -24.1 |
| 575.996648 | 30.04 | 46.00 | 15.96 | 1000.0 | 120.000 | 99.0 | H | 104.0 | -20.4 |
| 767.992325 | 27.97 | 46.00 | 18.03 | 1000.0 | 120.000 | 100.0 | H | 89.0 | -17.0 |

Note:

- 1.Emission level(QP)=Raw value by receiver + Corr(Antenna factor + cable loss - preamplifier gain)
- 2.The raw value is used to calculate by software which is not shown in the sheet.
- 3.Margin=limit value – emission level.

Mode 2:Adapter charging(N05)

Frequency Range: 1GHz –18GHz

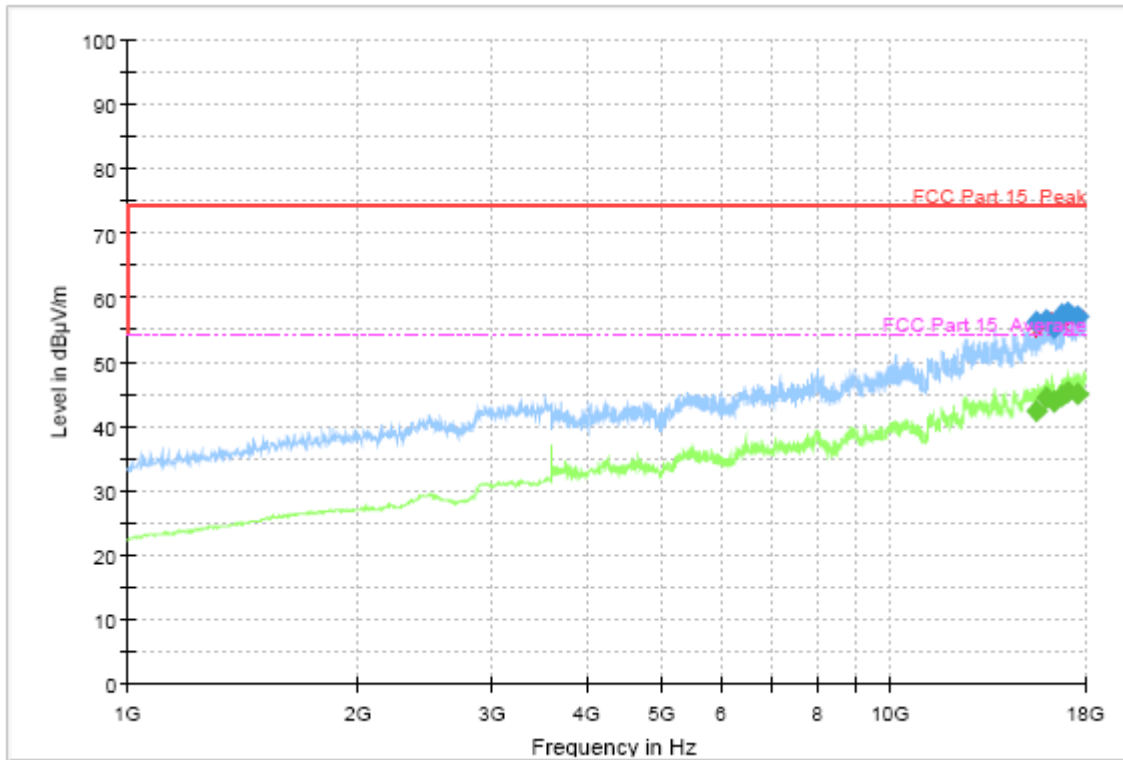

Final Result

| Frequency (MHz) | MaxPeak (dBuV/m) | Average (dBuV/m) | Limit (dBuV/m) | Margin (dB) | Meas. Time | Bandwidth (kHz) | Height (cm) | Pol | Azimuth (deg) |
|-----------------|------------------|------------------|----------------|-------------|------------|-----------------|-------------|-----|---------------|
| 15477.400000 | --- | 42.41 | 54.00 | 11.59 | 100.0 | 1000.000 | 100 | V | 0.0 |
| 15477.400000 | 56.17 | --- | 74.00 | 17.83 | 100.0 | 1000.000 | 100 | V | 0.0 |
| 15994.600000 | 56.45 | --- | 74.00 | 17.55 | 100.0 | 1000.000 | 200 | V | 63.0 |
| 15994.600000 | --- | 44.32 | 54.00 | 9.68 | 100.0 | 1000.000 | 200 | V | 63.0 |
| 16350.600000 | 55.40 | --- | 74.00 | 18.60 | 100.0 | 1000.000 | 100 | V | 314.0 |
| 16350.600000 | --- | 43.73 | 54.00 | 10.27 | 100.0 | 1000.000 | 100 | V | 314.0 |
| 16736.200000 | --- | 44.69 | 54.00 | 9.31 | 100.0 | 1000.000 | 100 | V | 180.0 |
| 16736.200000 | 57.33 | --- | 74.00 | 16.67 | 100.0 | 1000.000 | 100 | V | 180.0 |
| 17108.600000 | 57.62 | --- | 74.00 | 16.38 | 100.0 | 1000.000 | 200 | V | 0.0 |
| 17108.600000 | --- | 45.21 | 54.00 | 8.79 | 100.0 | 1000.000 | 200 | V | 0.0 |
| 17527.800000 | 57.18 | --- | 74.00 | 16.82 | 100.0 | 1000.000 | 200 | V | 210.0 |
| 17527.800000 | --- | 44.99 | 54.00 | 9.01 | 100.0 | 1000.000 | 200 | V | 210.0 |

Note:

- 1.Emission level(peak or average)=Raw value by receiver + Corr(Antenna factor+ cable loss - preamplifier gain)
- 2.The raw value is used to calculate by software which is not shown in the sheet.
- 3.Margin=limit value – emission level.

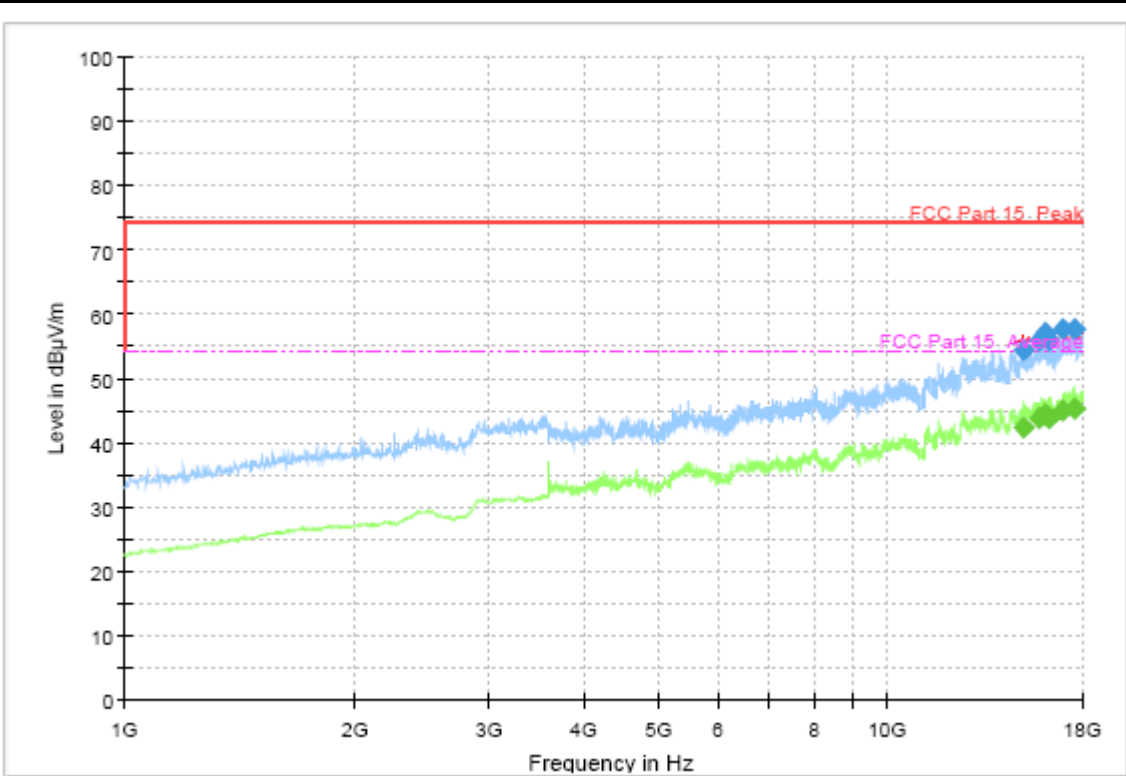

Final Result

| Frequency (MHz) | MaxPeak (dBuV/m) | Average (dBuV/m) | Limit (dBuV/m) | Margin (dB) | Meas. Time | Bandwidth (kHz) | Height (cm) | PoI | Azimuth (deg) |
|-----------------|------------------|------------------|----------------|-------------|------------|-----------------|-------------|-----|---------------|
| 15096.200000 | --- | 42.45 | 54.00 | 11.55 | 100.0 | 1000.000 | 100.0 | H | 0.0 |
| 15096.200000 | 54.36 | --- | 74.00 | 19.64 | 100.0 | 1000.000 | 100.0 | H | 0.0 |
| 15753.200000 | 55.94 | --- | 74.00 | 18.06 | 100.0 | 1000.000 | 100.0 | H | 285.0 |
| 15753.200000 | --- | 43.82 | 54.00 | 10.18 | 100.0 | 1000.000 | 100.0 | H | 285.0 |
| 16045.800000 | 56.98 | --- | 74.00 | 17.02 | 100.0 | 1000.000 | 200.0 | H | 139.0 |
| 16045.800000 | --- | 44.43 | 54.00 | 9.57 | 100.0 | 1000.000 | 200.0 | H | 139.0 |
| 16309.600000 | 55.78 | --- | 74.00 | 18.22 | 100.0 | 1000.000 | 100.0 | H | 110.0 |
| 16309.600000 | --- | 43.84 | 54.00 | 10.16 | 100.0 | 1000.000 | 100.0 | H | 110.0 |
| 17001.000000 | 57.54 | --- | 74.00 | 16.46 | 100.0 | 1000.000 | 200.0 | H | 346.0 |
| 17001.000000 | --- | 44.96 | 54.00 | 9.04 | 100.0 | 1000.000 | 200.0 | H | 346.0 |
| 17560.400000 | --- | 45.21 | 54.00 | 8.79 | 100.0 | 1000.000 | 200.0 | H | 90.0 |
| 17560.400000 | 57.53 | --- | 74.00 | 16.47 | 100.0 | 1000.000 | 200.0 | H | 90.0 |

Note:

1. Emission level (peak or average) = Raw value by receiver + Corr (Antenna factor + cable loss - preamplifier gain)
2. The raw value is used to calculate by software which is not shown in the sheet.
3. Margin = limit value - emission level.

Mode 1: USB cable (Data Link with PC)(N06)

Frequency Range: 30MHz – 1GHz

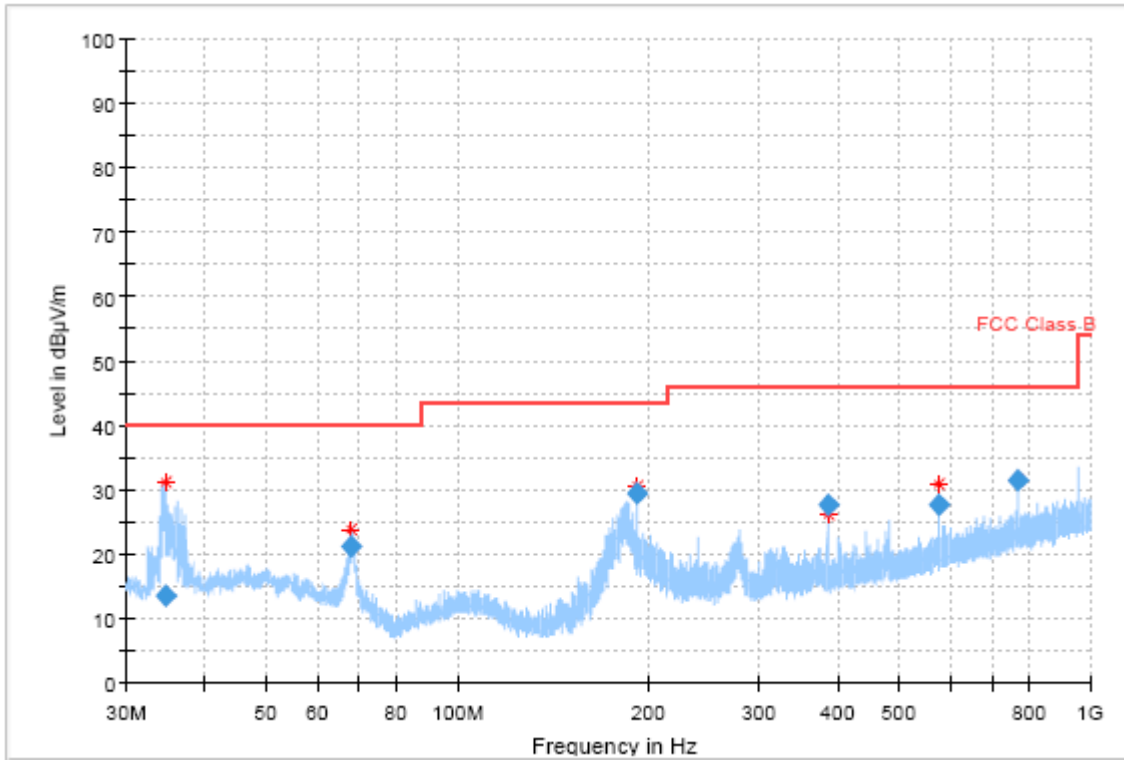

| Frequency (MHz) | QuasiPeak (dBuV/m) | Limit (dBuV/m) | Margin (dB) | Meas. Time (ms) | Bandwidth (kHz) | Height (cm) | PoI | Azimuth (deg) | Corr. (dB) |
|-----------------|--------------------|----------------|-------------|-----------------|-----------------|-------------|-----|---------------|------------|
| 34.520669 | 13.53 | 40.00 | 26.47 | 1000.0 | 120.000 | 100.0 | V | 110.0 | -27.7 |
| 68.149208 | 21.18 | 40.00 | 18.82 | 1000.0 | 120.000 | 105.0 | V | -4.0 | -29.5 |
| 191.992536 | 29.52 | 43.50 | 13.98 | 1000.0 | 120.000 | 180.0 | V | 162.0 | -28.7 |
| 383.993491 | 27.65 | 46.00 | 18.35 | 1000.0 | 120.000 | 105.0 | V | 150.0 | -24.1 |
| 576.043008 | 27.54 | 46.00 | 18.46 | 1000.0 | 120.000 | 100.0 | V | 197.0 | -20.4 |
| 767.995597 | 31.34 | 46.00 | 14.66 | 1000.0 | 120.000 | 125.0 | H | 37.0 | -17.0 |

Note:

- 1.Emission level(QP)=Raw value by receiver + Corr(Antenna factor + cable loss - preamplifier gain)
- 2.The raw value is used to calculate by software which is not shown in the sheet.
- 3.Margin=limit value – emission level.

Mode 2: Adapter charging(N06)

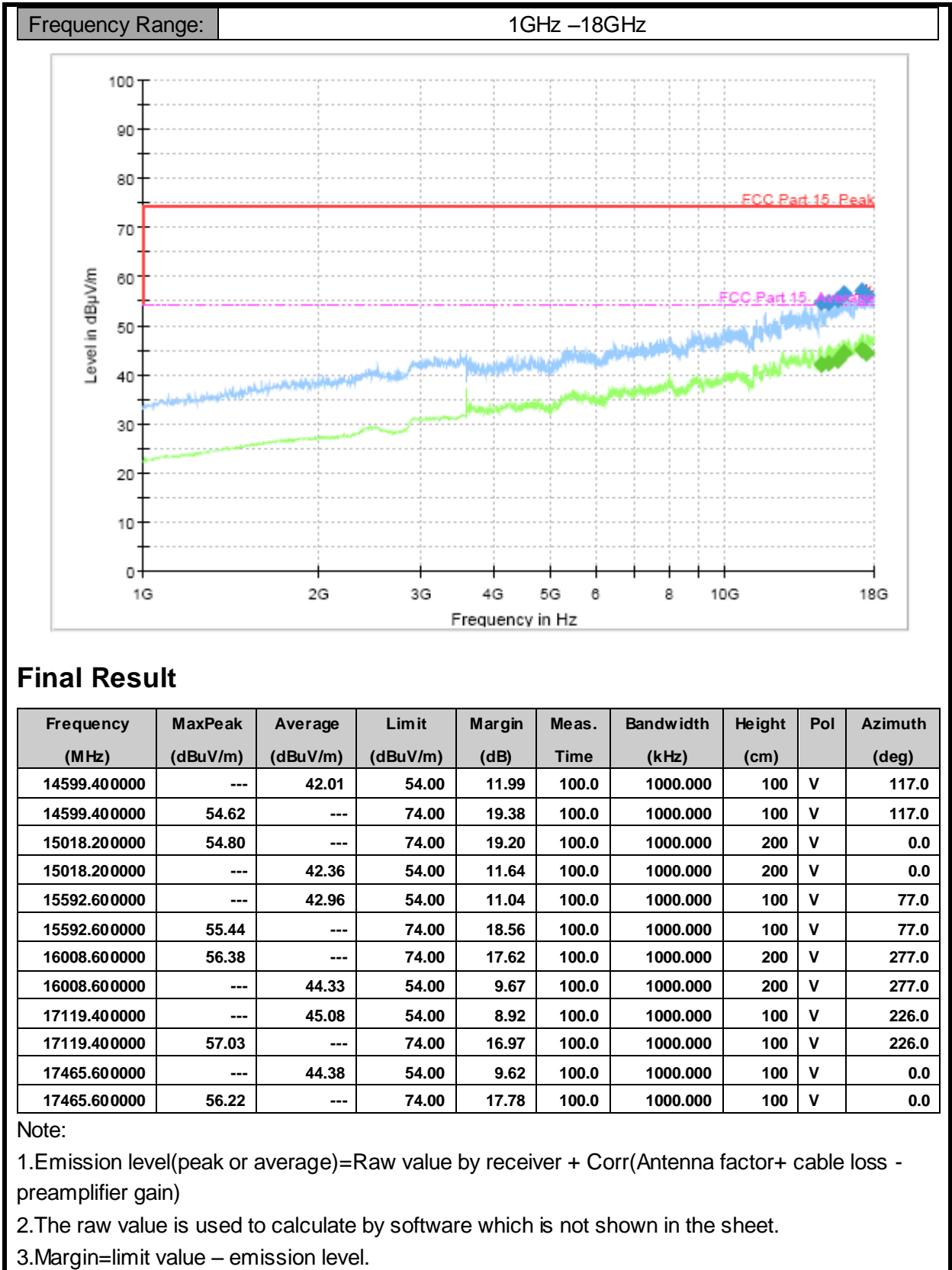

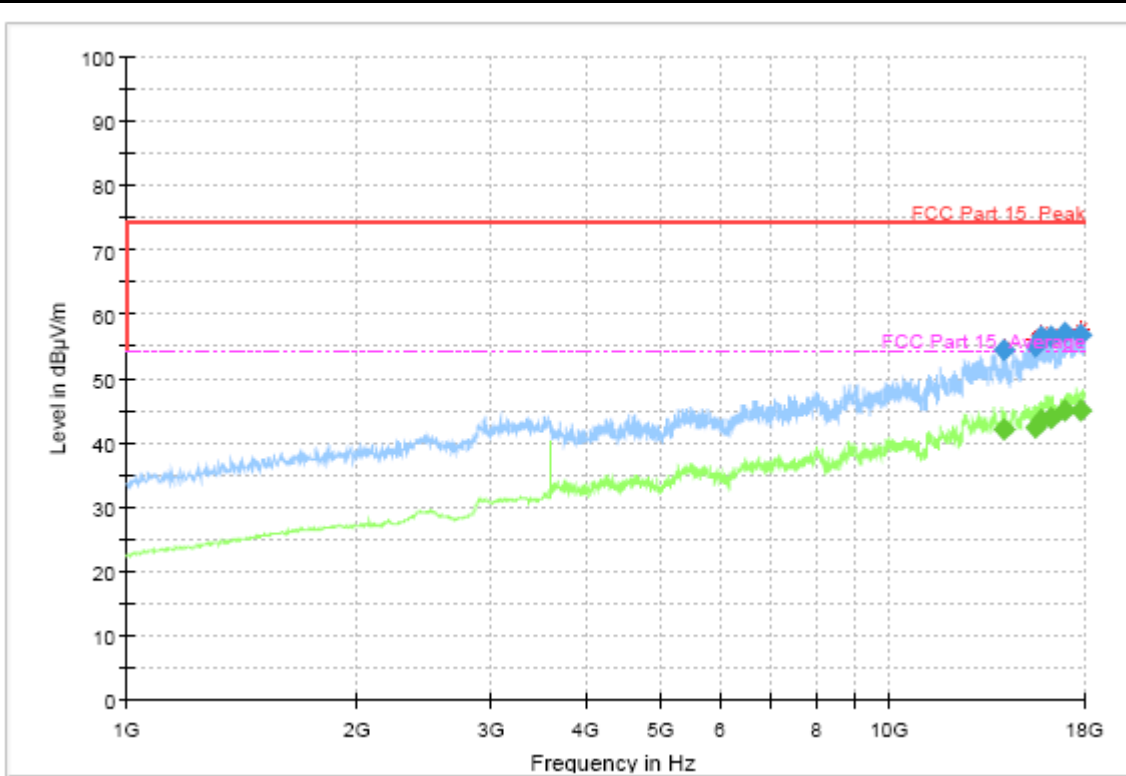

Final Result

| Frequency (MHz) | MaxPeak (dBuV/m) | Average (dBuV/m) | Limit (dBuV/m) | Margin (dB) | Meas. Time | Bandwidth (kHz) | Height (cm) | PoI | Azimuth (deg) |
|-----------------|------------------|------------------|----------------|-------------|------------|-----------------|-------------|-----|---------------|
| 14107.600000 | 54.33 | --- | 74.00 | 19.67 | 100.0 | 1000.000 | 200 | H | 51.0 |
| 14107.600000 | --- | 41.98 | 54.00 | 12.02 | 100.0 | 1000.000 | 200 | H | 51.0 |
| 15504.200000 | 55.11 | --- | 74.00 | 18.89 | 100.0 | 1000.000 | 100 | H | 216.0 |
| 15504.200000 | --- | 42.44 | 54.00 | 11.56 | 100.0 | 1000.000 | 100 | H | 216.0 |
| 15807.000000 | 56.40 | --- | 74.00 | 17.60 | 100.0 | 1000.000 | 100 | H | 165.0 |
| 15807.000000 | --- | 43.66 | 54.00 | 10.34 | 100.0 | 1000.000 | 100 | H | 165.0 |
| 16303.200000 | --- | 43.94 | 54.00 | 10.06 | 100.0 | 1000.000 | 100 | H | 0.0 |
| 16303.200000 | 56.33 | --- | 74.00 | 17.67 | 100.0 | 1000.000 | 100 | H | 0.0 |
| 17000.000000 | 57.09 | --- | 74.00 | 16.91 | 100.0 | 1000.000 | 100 | H | 247.0 |
| 17000.000000 | --- | 44.94 | 54.00 | 9.06 | 100.0 | 1000.000 | 100 | H | 247.0 |
| 17820.000000 | --- | 44.89 | 54.00 | 9.11 | 100.0 | 1000.000 | 200 | H | 0.0 |
| 17820.000000 | 56.71 | --- | 74.00 | 17.29 | 100.0 | 1000.000 | 200 | H | 0.0 |

Note:

- 1.Emission level(peak or average)=Raw value by receiver + Corr(Antenna factor+ cable loss - preamplifier gain)
- 2.The raw value is used to calculate by software which is not shown in the sheet.
- 3.Margin=limit value – emission level.

8.2 AC Conducted Emission

Method of Measurement

For equipment that is designed to be connected to the public utility (AC) power line, the radio frequency voltage that is conducted back onto the AC power line on any frequency or frequencies with the band 150 kHz to 30MHz shall not exceed the limits. Both lines of the power mains connected to the EUT were checked for maximum conducted interference. Tested in accordance with the procedures of ANSI C63.4-2014, section 7.3

Limit of Conducted Emission

| Frequency Range (MHz) | Conducted Limit (dBuV) | |
|-----------------------|------------------------|-----------|
| | Quasi-peak | Average |
| 0.15-0.5 | 66 to 56* | 56 to 46* |
| 0.5-5 | 56 | 46 |
| 5-30 | 60 | 50 |

*Decreases with the logarithm of the frequency

Test Condition in Charging Mode

| Voltage (V) | Frequency (Hz) | RBW | Sweep Time (s) |
|-------------|----------------|-------|----------------|
| 120 | 60 | 9 KHz | Auto |

Uncertainty Measurement

The measurement uncertainty is 3.66dB (k=2).

Test Results

Mode 1:Adapter charging(N02)

Frequency Range: 150kHz – 30MHz

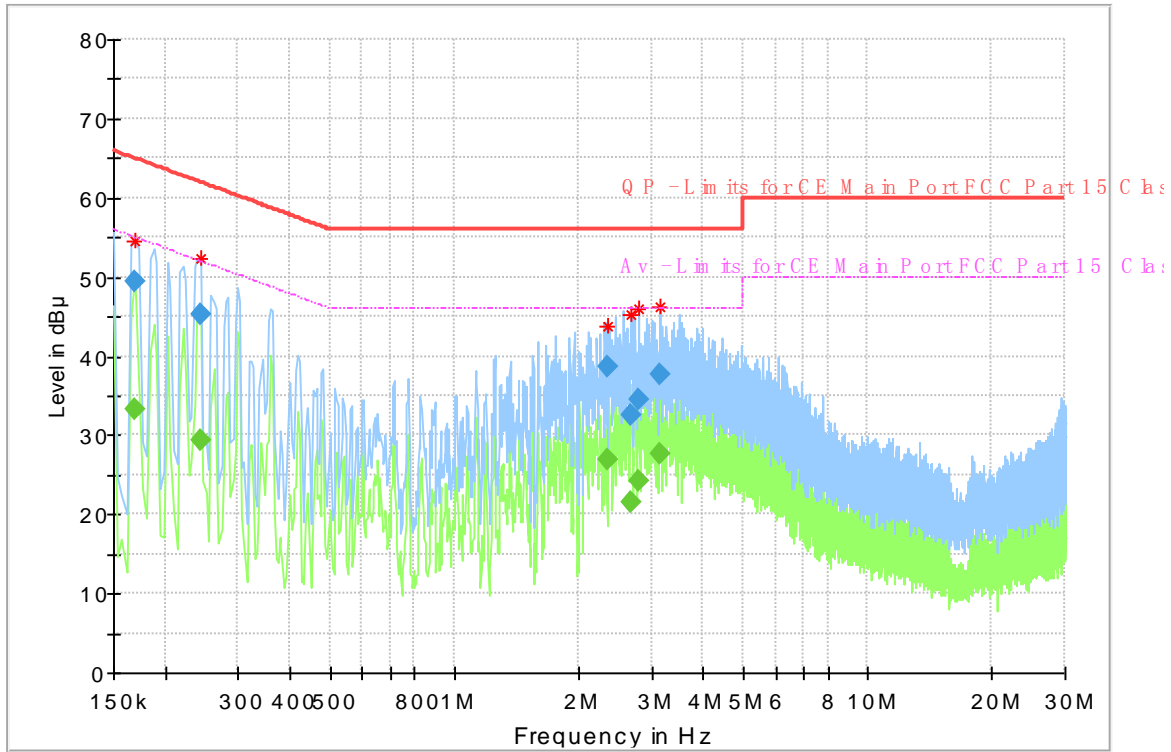

| Frequency (MHz) | QuasiPeak (dBµ V) | Average (dBµ V) | Limit (dBµ V) | Margin (dB) | Meas. Time | Bandwidth (kHz) | Line | Filter | Corr. (dB) |
|-----------------|-------------------|-----------------|---------------|-------------|------------|-----------------|------|--------|------------|
| 0.168656 | 49.51 | --- | 65.03 | 15.51 | 15000. | 9.000 | N | ON | 9.7 |
| 0.168656 | --- | 33.38 | 55.03 | 21.64 | 15000. | 9.000 | N | ON | 9.7 |
| 0.243281 | --- | 29.40 | 51.98 | 22.59 | 15000. | 9.000 | N | ON | 9.7 |
| 0.243281 | 45.22 | --- | 61.98 | 16.77 | 15000. | 9.000 | N | ON | 9.7 |
| 2.362631 | 38.61 | --- | 56.00 | 17.39 | 15000. | 9.000 | L1 | ON | 9.7 |
| 2.362631 | --- | 26.93 | 46.00 | 19.07 | 15000. | 9.000 | L1 | ON | 9.7 |
| 2.687250 | --- | 21.60 | 46.00 | 24.40 | 15000. | 9.000 | N | ON | 9.7 |
| 2.687250 | 32.51 | --- | 56.00 | 23.49 | 15000. | 9.000 | N | ON | 9.7 |
| 2.799188 | --- | 24.30 | 46.00 | 21.70 | 15000. | 9.000 | N | ON | 9.7 |
| 2.799188 | 34.57 | --- | 56.00 | 21.43 | 15000. | 9.000 | N | ON | 9.7 |
| 3.135000 | --- | 27.57 | 46.00 | 18.43 | 15000. | 9.000 | N | ON | 9.7 |
| 3.135000 | 37.63 | --- | 56.00 | 18.37 | 15000. | 9.000 | N | ON | 9.7 |

Note:

- 1.Emission level(quasi-peak or Average peak)=Raw value by receiver + Corr(Insertion loss+ cable loss)
- 2.The raw value is used to calculate by software which is not shown in the sheet.
- 3.Margin=limit value – emission level.
- 4.L1 and N line is all have been tested, the result of them is synthesized in the above data diagram.

Mode 1:Adapter charging(N05)

Frequency Range: 150kHz – 30MHz

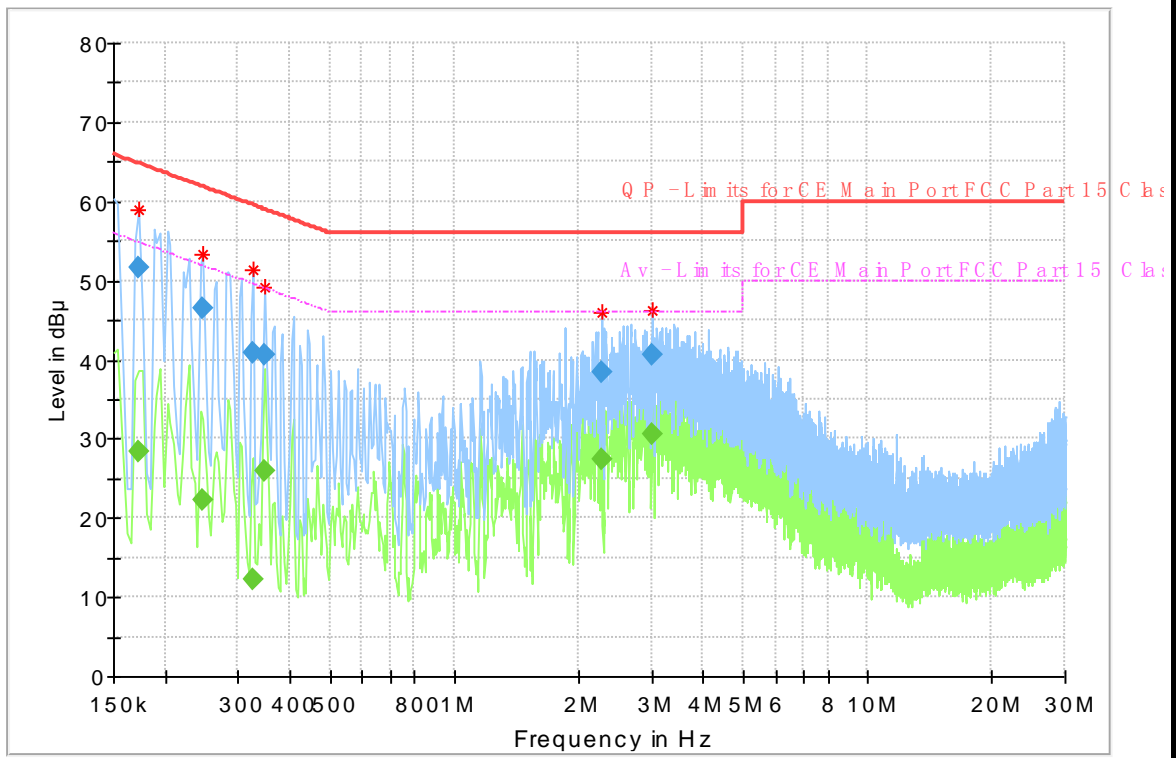

| Frequency (MHz) | QuasiPeak (dBµ V) | Average (dBµ V) | Limit (dBµ V) | Margin (dB) | Meas. Time | Bandwidth (kHz) | Line | Filter | Corr. (dB) |
|-----------------|-------------------|-----------------|---------------|-------------|------------|-----------------|------|--------|------------|
| 0.172388 | 51.74 | --- | 64.85 | 13.10 | 15000. | 9.000 | N | ON | 9.7 |
| 0.172388 | --- | 28.31 | 54.85 | 26.54 | 15000. | 9.000 | N | ON | 9.7 |
| 0.247013 | --- | 22.27 | 51.86 | 29.59 | 15000. | 9.000 | N | ON | 9.7 |
| 0.247013 | 46.44 | --- | 61.86 | 15.41 | 15000. | 9.000 | N | ON | 9.7 |
| 0.325369 | 40.88 | --- | 59.57 | 18.69 | 15000. | 9.000 | N | ON | 9.7 |
| 0.325369 | --- | 12.12 | 49.57 | 37.45 | 15000. | 9.000 | N | ON | 9.7 |
| 0.347756 | 40.53 | --- | 59.02 | 18.48 | 15000. | 9.000 | N | ON | 9.7 |
| 0.347756 | --- | 26.03 | 49.02 | 22.99 | 15000. | 9.000 | N | ON | 9.7 |
| 2.276813 | 38.31 | --- | 56.00 | 17.69 | 15000. | 9.000 | N | ON | 9.7 |
| 2.276813 | --- | 27.37 | 46.00 | 18.63 | 15000. | 9.000 | N | ON | 9.7 |
| 3.015600 | --- | 30.48 | 46.00 | 15.52 | 15000. | 9.000 | L1 | ON | 9.7 |
| 3.015600 | 40.50 | --- | 56.00 | 15.50 | 15000. | 9.000 | L1 | ON | 9.7 |

Note:

- 1.Emission level(quasi-peak or Average peak)=Raw value by receiver + Corr(Insertion loss+ cable loss)
- 2.The raw value is used to calculate by software which is not shown in the sheet.
- 3.Margin=limit value – emission level.
- 4.L1 and N line is all have been tested, the result of them is synthesized in the above data diagram.

Mode 1:Adapter charging(N06)

Frequency Range: 150kHz – 30MHz

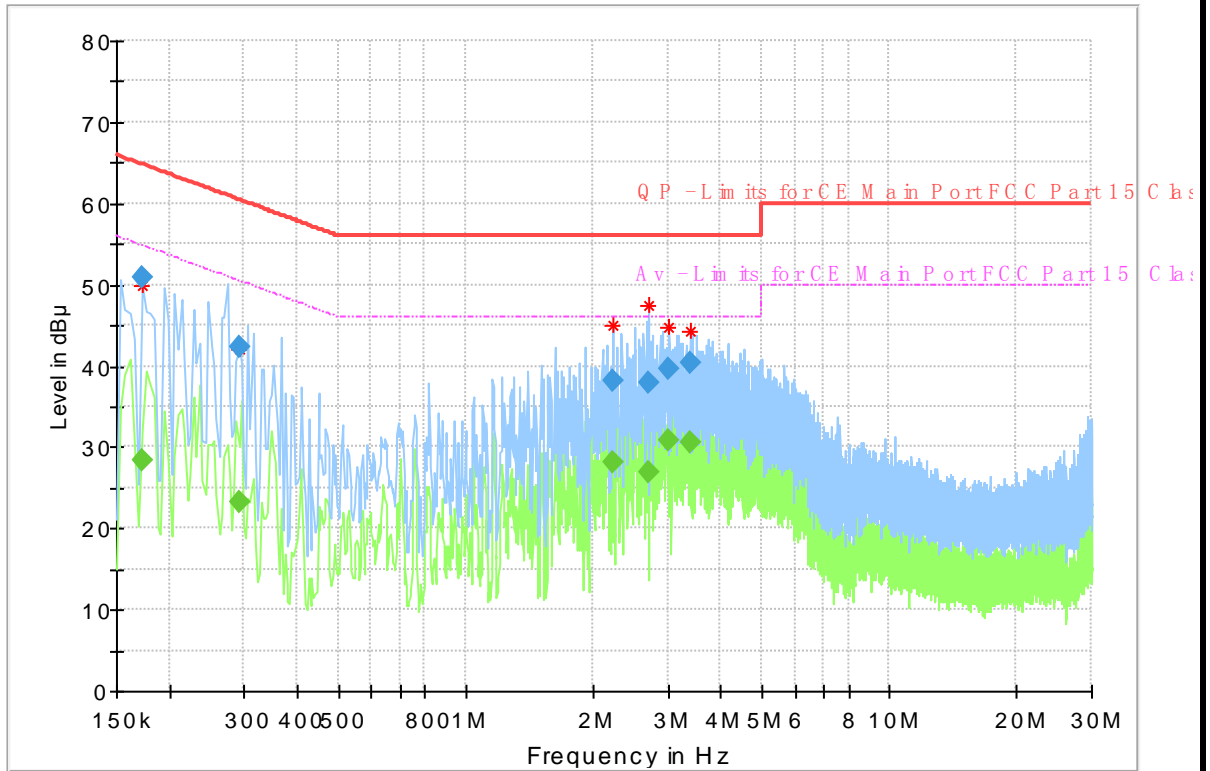

| Frequency (MHz) | QuasiPeak (dBu V) | Average (dBu V) | Limit (dBu V) | Margin (dB) | Meas. Time | Bandwidth (kHz) | Line | Filter | Corr. (dB) |
|-----------------|-------------------|-----------------|---------------|-------------|------------|-----------------|------|--------|------------|
| 0.172388 | 50.96 | --- | 64.85 | 13.88 | 15000.0 | 9.000 | N | ON | 9.7 |
| 0.172388 | --- | 28.29 | 54.85 | 26.55 | 15000.0 | 9.000 | N | ON | 9.7 |
| 0.291788 | 42.22 | --- | 60.47 | 18.25 | 15000.0 | 9.000 | N | ON | 9.7 |
| 0.291788 | --- | 23.21 | 50.47 | 27.26 | 15000.0 | 9.000 | N | ON | 9.7 |
| 2.220844 | 38.15 | --- | 56.00 | 17.85 | 15000.0 | 9.000 | N | ON | 9.7 |
| 2.220844 | --- | 28.06 | 46.00 | 17.94 | 15000.0 | 9.000 | N | ON | 9.7 |
| 2.690981 | 37.96 | --- | 56.00 | 18.04 | 15000.0 | 9.000 | N | ON | 9.7 |
| 2.690981 | --- | 26.79 | 46.00 | 19.21 | 15000.0 | 9.000 | N | ON | 9.7 |
| 3.026794 | --- | 30.72 | 46.00 | 15.28 | 15000.0 | 9.000 | L1 | ON | 9.7 |
| 3.026794 | 39.54 | --- | 56.00 | 16.46 | 15000.0 | 9.000 | L1 | ON | 9.7 |
| 3.381263 | --- | 30.51 | 46.00 | 15.49 | 15000.0 | 9.000 | L1 | ON | 9.7 |
| 3.381263 | 40.47 | --- | 56.00 | 15.53 | 15000.0 | 9.000 | L1 | ON | 9.7 |

Note:

1. Emission level (quasi-peak or Average peak) = Raw value by receiver + Corr (Insertion loss + cable loss)
2. The raw value is used to calculate by software which is not shown in the sheet.
3. Margin = limit value – emission level.
4. L1 and N line is all have been tested, the result of them is synthesized in the above data diagram.

*****END OF REPORT*****