



RF TEST REPORT

Applicant Mobiwire SAS
FCC ID QPN-LINIWA
Product 4G Smart Phone
Brand MobiWire, ALTICE
Model MobiWire Liniwa, ALTICE S23
Report No. R1912A0709-R3
Issue Date May 13, 2020

TA Technology (Shanghai) Co., Ltd. tested the above equipment in accordance with the requirements in **FCC CFR47 Part 2 (2019)/ FCC CFR47 Part 27C (2019)**. The test results show that the equipment tested is capable of demonstrating compliance with the requirements as documented in this report.

Performed by: Peng Tao

Approved by: Kai Xu

TA Technology (Shanghai) Co., Ltd.

No.145, Jintang Rd, Tangzhen Industry Park, Pudong Shanghai, China

TEL: +86-021-50791141/2/3

FAX: +86-021-50791141/2/3-8000



TABLE OF CONTENT

1	Test Laboratory.....	4
1.1	Notes of the Test Report.....	4
1.2.	Test facility.....	4
1.3	Testing Location.....	4
2	General Description of Equipment under Test.....	5
2.1	Applicant and Manufacturer Information.....	5
2.2	General information.....	5
3	Applied Standards.....	7
4	Test Configuration.....	8
5	Test Case Results.....	9
5.1	RF Power Output and Effective Isotropic Radiated Power.....	9
5.2	Occupied Bandwidth.....	17
5.3	Band Edge Compliance.....	23
5.4	Peak-to-Average Power Ratio (PAPR).....	31
5.5	Frequency Stability.....	33
5.6	Spurious Emissions at Antenna Terminals.....	36
5.7	Radiates Spurious Emission.....	40
6	Main Test Instruments.....	44



Summary of Measurement Results

Number	Test Case	Clause in FCC rules	Verdict
1	RF Power Output and Effective Isotropic Radiated Power	2.1046 /27.50(h)(2)	PASS
2	Occupied Bandwidth	2.1049	PASS
3	Band Edge Compliance	/27.53(m)	PASS
4	Peak-to-Average Power Ratio	27.50(d)/KDB971168 D01(5.7)	PASS
5	Frequency Stability	2.1055 / 27.54	PASS
6	Spurious Emissions at Antenna Terminals	2.1051 /27.53(m)	PASS
7	Radiates Spurious Emission	2.1053 /27.53(h) /27.53(g) /27.53(m) /27.53(f) /27.53(c)	PASS

Date of Testing: February 15,2020~ March 18,2020

Note: PASS: The EUT complies with the essential requirements in the standard.

FAIL: The EUT does not comply with the essential requirements in the standard.

All indications of Pass/Fail in this report are opinions expressed by TA Technology (Shanghai) Co., Ltd. based on interpretations and/or observations of test results. Measurement Uncertainties were not taken into account and are published for informational purposes only.



1 Test Laboratory

1.1 Notes of the Test Report

This report shall not be reproduced in full or partial, without the written approval of **TA technology (shanghai) co., Ltd.** The results documented in this report apply only to the tested sample, under the conditions and modes of operation as described herein .Measurement Uncertainties were not taken into account and are published for informational purposes only. This report is written to support regulatory compliance of the applicable standards stated above.

1.2. Test facility

FCC (Designation number: CN1179, Test Firm Registration Number: 446626)

TA Technology (Shanghai) Co., Ltd. has been listed on the US Federal Communications Commission list of test facilities recognized to perform electromagnetic emissions measurements.

A2LA (Certificate Number: 3857.01)

TA Technology (Shanghai) Co., Ltd. has been listed by American Association for Laboratory Accreditation to perform electromagnetic emission measurement.

1.3 Testing Location

Company: TA Technology (Shanghai) Co., Ltd.
Address: No.145, Jintang Rd, Tangzhen Industry Park, Pudong Shanghai, China
City: Shanghai
Post code: 201201
Country: P. R. China
Contact: Xu Kai
Telephone: +86-021-50791141/2/3
Fax: +86-021-50791141/2/3-8000
Website: <http://www.ta-shanghai.com>
E-mail: xukai@ta-shanghai.com

2 General Description of Equipment under Test

2.1 Applicant and Manufacturer Information

Applicant	Mobiwire SAS
Applicant address	79 AVENUE FRANCOIS ARAGO 92017 NANTERRE CEDEX France
Manufacturer	Mobiwire SAS
Manufacturer address	79 AVENUE FRANCOIS ARAGO 92017 NANTERRE CEDEX France

2.2 General information

EUT Description			
Model	MobiWire Liniwa, ALTICE S23		
IMEI	353633110000503		
Hardware Version	V01		
Software Version	MOBIWIRE_GH5032		
Power Supply	Battery/AC adapter		
Antenna Type	Internal Antenna		
Antenna Gain	0dBi		
Test Mode(s)	LTE Band 7;		
Test Modulation	(LTE)QPSK 16QAM;		
LTE Category	4		
Maximum E.I.R.P./ E.R.P.	LTE Band 7:	23.08dBm	
Rated Power Supply Voltage:	3.8V		
Extreme Voltage	Minimum: 3.6V Maximum: 4.35V		
Extreme Temperature	Lowest: -10°C Highest: +55°C		
Operating Frequency Range(s)	Mode	Tx (MHz)	Rx (MHz)
	LTE Band 7	2500 ~ 2570	2620 ~ 2690
EUT Accessory			
Adapter 1	Manufacturer: Dongguan Aohai Power Technology CO.,LTD Model: A31A-050100U-EU1		
Adapter 2	Manufacturer: Dongguan Aohai Power Technology CO.,LTD Model: A31A-050100U-US1		
Battery	Manufacturer: GUANGDONG FENGHUA NEW ENERGY CO.,LTD Model: 178172056		
Earphone	Manufacturer: Shenzhen Juwei Electronics Co.,Ltd Model: JWEP0957-M01R		
USB Cable	Manufacturer: SHENZHEN FKY-QY HARDWARE		



	ELECTRONIC CO.,LTD Model: 2CA0MBWE001
<p>Note: 1. The EUT is sent from the applicant to TA and the information of the EUT is declared by the applicant.</p> <p>2. There are more than one Adapter, each one should be applied throughout the compliance test respectively, however, only the worst case (Adapter1) will be recorded in this report.</p>	

Customer declaration, the two models(MobiWire Liniwa and ALTICE S23) are same as Orange Nola play, except for model name, brand, TP and battery cover. Each one should be applied throughout the compliance test respectively, however, only the worst case (ALTICE S23) will be recorded in this report.



3 Applied Standards

According to the specifications of the manufacturer, it must comply with the requirements of the following standards:

Test standards:

FCC CFR47 Part 27C (2019)

ANSI C63.26 (2015)

Reference standard:

FCC CFR47 Part 2 (2019)

KDB 971168 D01 Power Meas License Digital Systems v03r01

4 Test Configuration

Radiated measurements are performed by rotating the EUT in three different orthogonal test planes. EUT stand-up position (Z axis), lie-down position (X, Y axis). Receiver antenna polarization (horizontal and vertical), the worst emission was found in position (Z axis, horizontal polarization) and the worst case was recorded.

All mode and data rates and positions and RB size and modulations were investigated. Subsequently, only the worst case emissions are reported.

The following testing in LTE is set based on the maximum RF Output Power.

The following testing in different Bandwidth is set to detail in the following table:

Test modes are chosen to be reported as the worst case configuration below for LTE Band 7:

Test items	Modes	Bandwidth (MHz)						Modulation		RB			Test Channel			
		1.4	3	5	10	15	20	QPSK	16QAM	1	50%	100%	L	M	H	
RF Power Output and Effective Isotropic Radiated Power	LTE 7	-	-	O	O	O	O	O	O	O	O	O	O	O	O	O
Occupied Bandwidth	LTE 7	-	-	O	O	O	O	O	O	-	-	O	O	O	O	
Band Edge Compliance	LTE 7	-	-	O	O	O	O	O	O	O	-	O	O	-	O	
Peak-to-Average Power Ratio	LTE 7	-	-	O	O	O	O	O	O	-	-	O	O	O	O	
Frequency Stability	LTE 7	-	-	O	O	O	O	O	O	O	O	O	O	O	O	
Spurious Emissions at Antenna Terminals	LTE 7	-	-	O	O	O	O	O	-	O	-	-	O	O	O	
Radiates Spurious Emission	LTE 7	-	-	O	-	-	O	O	-	O	-	-	-	O	-	
Note	1. The mark "O" means that this configuration is chosen for testing. 2. The mark "-" means that this configuration is not testing.															

5 Test Case Results

5.1 RF Power Output and Effective Isotropic Radiated Power

Ambient condition

Temperature	Relative humidity	Pressure
23°C ~25°C	45%~50%	101.5kPa

Methods of Measurement

During the process of the testing, The EUT is controlled by the Base Station Simulator to ensure max power transmission and proper modulation.

1. The testing follows FCC KDB 971168 D01 v03r01 Section 5.8 and ANSI C63.26 (2015).

- a) Connect the equipment as illustrated. Mount the equipment with the manufacturer specified antenna in a vertical orientation on a manufacturer specified mounting surface located on a non-conducting rotating platform of a RF anechoic chamber (preferred) or a standard radiation site.
- b) Key the transmitter, then rotate the EUT 360° azimuthally and record spectrum analyzer power level (LVL) measurements at angular increments that are sufficiently small to permit resolution of all peaks. If a standard radiation test site is used, raise and lower the test antenna to obtain a maximum reading at each angular increment. (Note: several batteries may be needed to offset the effect of battery voltage droop, which should not exceed 5% of the manufactured specified battery voltage during transmission).
- c) Replace the transmitter under test with a vertically polarized half-wave dipole (or an antenna whose gain is known relative to an ideal half-wave dipole). The center of the antenna should be at the same location as the center of the antenna under test.
- d) Connect the antenna to a signal generator with a known output power and record the path loss (in dB) as LOSS. If a standard radiation test site is used, raise and lower the test antenna to obtain a maximum reading. $LOSS = \text{Generator Output Power (dBm)} - \text{Analyzer reading (dBm)}$
- e) Determine the effective radiated output power at each angular position from the readings in steps b) and d) using the following equation: $ERP \text{ (dBm)} = \text{LVL (dBm)} + \text{LOSS (dB)}$
- f) The maximum ERP is the maximum value determined in the preceding step.
- g) When calculating ERP, in addition to knowing the antenna radiation and matching characteristics, it is necessary to know the loss values of all elements (e.g. transmission line attenuation, mismatches, filters, combiners) interposed between the point where transmitter output power is measured, and the point where power is applied to the antenna. ERP can then be calculated as follows:

$$EIRP \text{ (dBm)} = \text{Output Power (dBm)} - \text{Losses (dB)} + \text{Antenna Gain (dBi)}$$

where: dBd refers to gain relative to an ideal dipole.

$$EIRP \text{ (dBm)} = ERP \text{ (dBm)} + 2.15 \text{ (dB.)}$$

The RB allocation refers to section 5.1, using the maximum output power configuration.

Test Setup

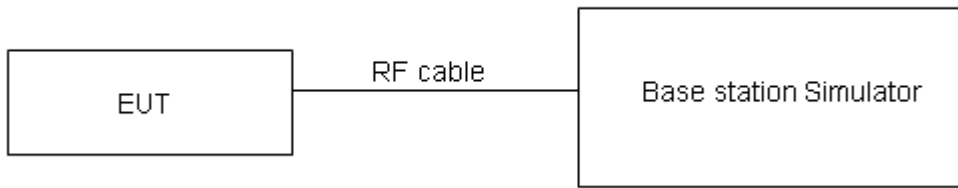

The loss between RF output port of the EUT and the input port of the tester has been taken into consideration.

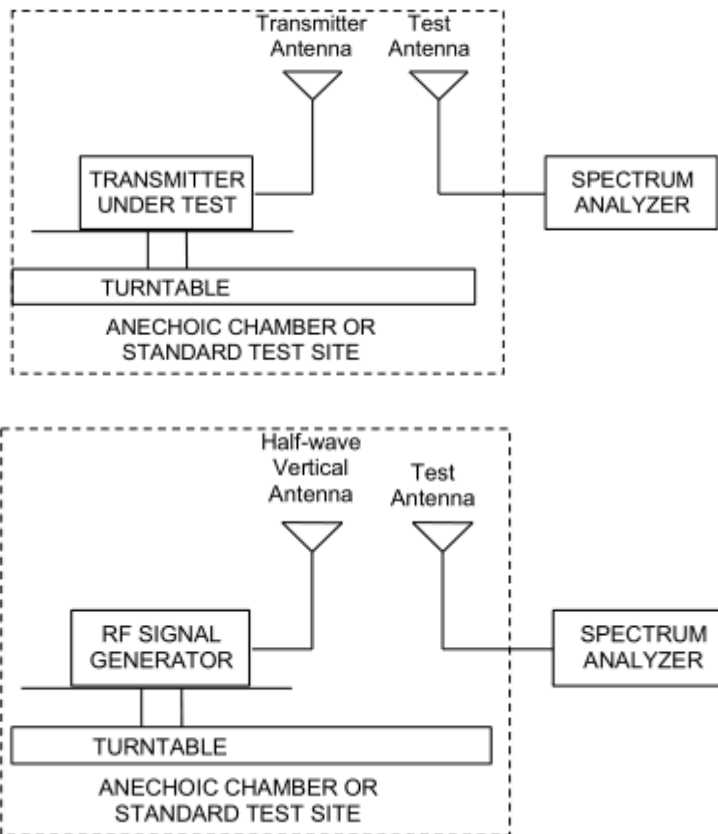

Note: Area side:2.4mX3.6m

The radiated emission was measured in the following position: EUT stand-up position (Z axis), lie-down position (X, Y axis). The worst emission was found in stand-up position (Z axis) and the worst case was recorded.

Limits

No specific RF power output requirements in part 2.1046.

Rule Part 27.50(h) (2) specifies that “Mobile and other user stations. Mobile stations are limited to 2.0 watts EIRP. All user stations are limited to 2.0 watts transmitter output power.”

Part 27.50(h)(2) Limit	≤ 2 W (33 dBm)
------------------------	----------------



Measurement Uncertainty

The assessed measurement uncertainty to ensure 95% confidence level for the normal distribution is with the coverage factor $k = 2$, $U=0.4$ dB for RF power output, $k = 2$, $U= 1.19$ dB for ERP/EIRP.

**Test Results**

BAND	Bandwidth	Modulation	Channel	RB Configuration	Conducted Power(dBm)	EIRP (dBm)	Verdict
Band7	5M	QPSK	20775	1RB#0	22.53	22.53	PASS
Band7	5M	QPSK	20775	1RB#13	22.98	22.98	PASS
Band7	5M	QPSK	20775	1RB#24	22.61	22.61	PASS
Band7	5M	QPSK	20775	12RB#0	21.74	21.74	PASS
Band7	5M	QPSK	20775	12RB#6	21.77	21.77	PASS
Band7	5M	QPSK	20775	12RB#13	21.83	21.83	PASS
Band7	5M	QPSK	20775	25RB#0	21.75	21.75	PASS
Band7	5M	QPSK	21100	1RB#0	22.69	22.69	PASS
Band7	5M	QPSK	21100	1RB#13	23.02	23.02	PASS
Band7	5M	QPSK	21100	1RB#24	22.74	22.74	PASS
Band7	5M	QPSK	21100	12RB#0	21.93	21.93	PASS
Band7	5M	QPSK	21100	12RB#6	21.92	21.92	PASS
Band7	5M	QPSK	21100	12RB#13	21.94	21.94	PASS
Band7	5M	QPSK	21100	25RB#0	21.99	21.99	PASS
Band7	5M	QPSK	21425	1RB#0	22.6	22.6	PASS
Band7	5M	QPSK	21425	1RB#13	23.08	23.08	PASS
Band7	5M	QPSK	21425	1RB#24	22.83	22.83	PASS
Band7	5M	QPSK	21425	12RB#0	21.98	21.98	PASS
Band7	5M	QPSK	21425	12RB#6	22.02	22.02	PASS
Band7	5M	QPSK	21425	12RB#13	21.9	21.9	PASS
Band7	5M	QPSK	21425	25RB#0	21.89	21.89	PASS
Band7	5M	16QAM	20775	1RB#0	21.85	21.85	PASS
Band7	5M	16QAM	20775	1RB#13	22.18	22.18	PASS
Band7	5M	16QAM	20775	1RB#24	21.82	21.82	PASS
Band7	5M	16QAM	20775	12RB#0	20.69	20.69	PASS
Band7	5M	16QAM	20775	12RB#6	20.72	20.72	PASS
Band7	5M	16QAM	20775	12RB#13	20.77	20.77	PASS
Band7	5M	16QAM	20775	25RB#0	20.75	20.75	PASS
Band7	5M	16QAM	21100	1RB#0	21.71	21.71	PASS
Band7	5M	16QAM	21100	1RB#13	22.21	22.21	PASS
Band7	5M	16QAM	21100	1RB#24	21.9	21.9	PASS
Band7	5M	16QAM	21100	12RB#0	20.8	20.8	PASS



Band7	5M	16QAM	21100	12RB#6	20.87	20.87	PASS
Band7	5M	16QAM	21100	12RB#13	20.88	20.88	PASS
Band7	5M	16QAM	21100	25RB#0	20.84	20.84	PASS
Band7	5M	16QAM	21425	1RB#0	22.14	22.14	PASS
Band7	5M	16QAM	21425	1RB#13	22.59	22.59	PASS
Band7	5M	16QAM	21425	1RB#24	22.27	22.27	PASS
Band7	5M	16QAM	21425	12RB#0	20.94	20.94	PASS
Band7	5M	16QAM	21425	12RB#6	20.94	20.94	PASS
Band7	5M	16QAM	21425	12RB#13	20.89	20.89	PASS
Band7	5M	16QAM	21425	25RB#0	20.91	20.91	PASS
Band7	10M	QPSK	20800	1RB#0	22.48	22.48	PASS
Band7	10M	QPSK	20800	1RB#25	22.92	22.92	PASS
Band7	10M	QPSK	20800	1RB#49	22.54	22.54	PASS
Band7	10M	QPSK	20800	25RB#0	21.67	21.67	PASS
Band7	10M	QPSK	20800	25RB#13	21.73	21.73	PASS
Band7	10M	QPSK	20800	25RB#25	21.76	21.76	PASS
Band7	10M	QPSK	20800	50RB#0	21.73	21.73	PASS
Band7	10M	QPSK	21100	1RB#0	22.56	22.56	PASS
Band7	10M	QPSK	21100	1RB#25	22.98	22.98	PASS
Band7	10M	QPSK	21100	1RB#49	22.66	22.66	PASS
Band7	10M	QPSK	21100	25RB#0	21.89	21.89	PASS
Band7	10M	QPSK	21100	25RB#13	21.88	21.88	PASS
Band7	10M	QPSK	21100	25RB#25	21.86	21.86	PASS
Band7	10M	QPSK	21100	50RB#0	21.91	21.91	PASS
Band7	10M	QPSK	21400	1RB#0	22.54	22.54	PASS
Band7	10M	QPSK	21400	1RB#25	23.02	23.02	PASS
Band7	10M	QPSK	21400	1RB#49	22.73	22.73	PASS
Band7	10M	QPSK	21400	25RB#0	21.92	21.92	PASS
Band7	10M	QPSK	21400	25RB#13	21.97	21.97	PASS
Band7	10M	QPSK	21400	25RB#25	21.91	21.91	PASS
Band7	10M	QPSK	21400	50RB#0	21.9	21.9	PASS
Band7	10M	16QAM	20800	1RB#0	21.82	21.82	PASS
Band7	10M	16QAM	20800	1RB#25	22.16	22.16	PASS
Band7	10M	16QAM	20800	1RB#49	21.8	21.8	PASS
Band7	10M	16QAM	20800	25RB#0	20.66	20.66	PASS



Band7	10M	16QAM	20800	25RB#13	20.69	20.69	PASS
Band7	10M	16QAM	20800	25RB#25	20.72	20.72	PASS
Band7	10M	16QAM	20800	50RB#0	20.73	20.73	PASS
Band7	10M	16QAM	21100	1RB#0	21.68	21.68	PASS
Band7	10M	16QAM	21100	1RB#25	22.16	22.16	PASS
Band7	10M	16QAM	21100	1RB#49	21.83	21.83	PASS
Band7	10M	16QAM	21100	25RB#0	20.77	20.77	PASS
Band7	10M	16QAM	21100	25RB#13	20.82	20.82	PASS
Band7	10M	16QAM	21100	25RB#25	20.88	20.88	PASS
Band7	10M	16QAM	21100	50RB#0	20.84	20.84	PASS
Band7	10M	16QAM	21400	1RB#0	22.09	22.09	PASS
Band7	10M	16QAM	21400	1RB#25	22.55	22.55	PASS
Band7	10M	16QAM	21400	1RB#49	22.23	22.23	PASS
Band7	10M	16QAM	21400	25RB#0	20.9	20.9	PASS
Band7	10M	16QAM	21400	25RB#13	20.88	20.88	PASS
Band7	10M	16QAM	21400	25RB#25	20.86	20.86	PASS
Band7	10M	16QAM	21400	50RB#0	20.89	20.89	PASS
Band7	15M	QPSK	20825	1RB#0	22.47	22.47	PASS
Band7	15M	QPSK	20825	1RB#38	22.9	22.9	PASS
Band7	15M	QPSK	20825	1RB#74	22.51	22.51	PASS
Band7	15M	QPSK	20825	36RB#0	21.65	21.65	PASS
Band7	15M	QPSK	20825	36RB#18	21.7	21.7	PASS
Band7	15M	QPSK	20825	36RB#39	21.73	21.73	PASS
Band7	15M	QPSK	20825	75RB#0	21.71	21.71	PASS
Band7	15M	QPSK	21100	1RB#0	22.52	22.52	PASS
Band7	15M	QPSK	21100	1RB#38	22.97	22.97	PASS
Band7	15M	QPSK	21100	1RB#74	22.61	22.61	PASS
Band7	15M	QPSK	21100	36RB#0	21.85	21.85	PASS
Band7	15M	QPSK	21100	36RB#18	21.83	21.83	PASS
Band7	15M	QPSK	21100	36RB#39	21.83	21.83	PASS
Band7	15M	QPSK	21100	75RB#0	21.87	21.87	PASS
Band7	15M	QPSK	21375	1RB#0	22.52	22.52	PASS
Band7	15M	QPSK	21375	1RB#38	22.99	22.99	PASS
Band7	15M	QPSK	21375	1RB#74	22.69	22.69	PASS
Band7	15M	QPSK	21375	36RB#0	21.89	21.89	PASS



Band7	15M	QPSK	21375	36RB#18	21.93	21.93	PASS
Band7	15M	QPSK	21375	36RB#39	21.87	21.87	PASS
Band7	15M	QPSK	21375	75RB#0	21.85	21.85	PASS
Band7	15M	16QAM	20825	1RB#0	21.77	21.77	PASS
Band7	15M	16QAM	20825	1RB#38	22.14	22.14	PASS
Band7	15M	16QAM	20825	1RB#74	21.77	21.77	PASS
Band7	15M	16QAM	20825	36RB#0	20.63	20.63	PASS
Band7	15M	16QAM	20825	36RB#18	20.66	20.66	PASS
Band7	15M	16QAM	20825	36RB#39	20.7	20.7	PASS
Band7	15M	16QAM	20825	75RB#0	20.7	20.7	PASS
Band7	15M	16QAM	21100	1RB#0	21.66	21.66	PASS
Band7	15M	16QAM	21100	1RB#38	22.13	22.13	PASS
Band7	15M	16QAM	21100	1RB#74	21.79	21.79	PASS
Band7	15M	16QAM	21100	36RB#0	20.75	20.75	PASS
Band7	15M	16QAM	21100	36RB#18	20.77	20.77	PASS
Band7	15M	16QAM	21100	36RB#39	20.84	20.84	PASS
Band7	15M	16QAM	21100	75RB#0	20.79	20.79	PASS
Band7	15M	16QAM	21375	1RB#0	22.07	22.07	PASS
Band7	15M	16QAM	21375	1RB#38	22.53	22.53	PASS
Band7	15M	16QAM	21375	1RB#74	22.2	22.2	PASS
Band7	15M	16QAM	21375	36RB#0	20.87	20.87	PASS
Band7	15M	16QAM	21375	36RB#18	20.84	20.84	PASS
Band7	15M	16QAM	21375	36RB#39	20.83	20.83	PASS
Band7	15M	16QAM	21375	75RB#0	20.85	20.85	PASS
Band7	20M	QPSK	20850	1RB#0	22.44	22.44	PASS
Band7	20M	QPSK	20850	1RB#50	22.89	22.89	PASS
Band7	20M	QPSK	20850	1RB#99	22.49	22.49	PASS
Band7	20M	QPSK	20850	50RB#0	21.62	21.62	PASS
Band7	20M	QPSK	20850	50RB#25	21.68	21.68	PASS
Band7	20M	QPSK	20850	50RB#50	21.7	21.7	PASS
Band7	20M	QPSK	20850	100RB#0	21.68	21.68	PASS
Band7	20M	QPSK	21100	1RB#0	22.48	22.48	PASS
Band7	20M	QPSK	21100	1RB#50	22.93	22.93	PASS
Band7	20M	QPSK	21100	1RB#99	22.6	22.6	PASS
Band7	20M	QPSK	21100	50RB#0	21.8	21.8	PASS



Band7	20M	QPSK	21100	50RB#25	21.79	21.79	PASS
Band7	20M	QPSK	21100	50RB#50	21.78	21.78	PASS
Band7	20M	QPSK	21100	100RB#0	21.82	21.82	PASS
Band7	20M	QPSK	21350	1RB#0	22.49	22.49	PASS
Band7	20M	QPSK	21350	1RB#50	22.97	22.97	PASS
Band7	20M	QPSK	21350	1RB#99	22.66	22.66	PASS
Band7	20M	QPSK	21350	50RB#0	21.85	21.85	PASS
Band7	20M	QPSK	21350	50RB#25	21.9	21.9	PASS
Band7	20M	QPSK	21350	50RB#50	21.83	21.83	PASS
Band7	20M	QPSK	21350	100RB#0	21.81	21.81	PASS
Band7	20M	16QAM	20850	1RB#0	21.75	21.75	PASS
Band7	20M	16QAM	20850	1RB#50	22.1	22.1	PASS
Band7	20M	16QAM	20850	1RB#99	21.75	21.75	PASS
Band7	20M	16QAM	20850	50RB#0	20.6	20.6	PASS
Band7	20M	16QAM	20850	50RB#25	20.63	20.63	PASS
Band7	20M	16QAM	20850	50RB#50	20.67	20.67	PASS
Band7	20M	16QAM	20850	100RB#0	20.68	20.68	PASS
Band7	20M	16QAM	21100	1RB#0	21.62	21.62	PASS
Band7	20M	16QAM	21100	1RB#50	22.11	22.11	PASS
Band7	20M	16QAM	21100	1RB#99	21.76	21.76	PASS
Band7	20M	16QAM	21100	50RB#0	20.71	20.71	PASS
Band7	20M	16QAM	21100	50RB#25	20.75	20.75	PASS
Band7	20M	16QAM	21100	50RB#50	20.79	20.79	PASS
Band7	20M	16QAM	21100	100RB#0	20.75	20.75	PASS
Band7	20M	16QAM	21350	1RB#0	22.02	22.02	PASS
Band7	20M	16QAM	21350	1RB#50	22.49	22.49	PASS
Band7	20M	16QAM	21350	1RB#99	22.18	22.18	PASS
Band7	20M	16QAM	21350	50RB#0	20.84	20.84	PASS
Band7	20M	16QAM	21350	50RB#25	20.81	20.81	PASS
Band7	20M	16QAM	21350	50RB#50	20.79	20.79	PASS
Band7	20M	16QAM	21350	100RB#0	20.82	20.82	PASS

5.2 Occupied Bandwidth

Ambient condition

Temperature	Relative humidity	Pressure
23°C ~25°C	45%~50%	101.5kPa

Method of Measurement

The EUT was connected to Spectrum Analyzer and Base Station Simulator via power Splitter. The occupied bandwidth is measured using spectrum analyzer.

RBW is set to 100 kHz, VBW is set to 300 kHz for LTE Band 7 (5MHz).

RBW is set to 200 kHz, VBW is set to 620kHz for LTE Band 7 (10MHz).

RBW is set to 300 kHz, VBW is set to 910kHz for LTE Band 7 (15MHz).

RBW is set to 430 kHz, VBW is set to 1.2MHz for LTE Band 7 (20MHz).

99% power and -26dBc occupied bandwidths are recorded. Spectrum analyzer plots are included on the following pages.

Test Setup

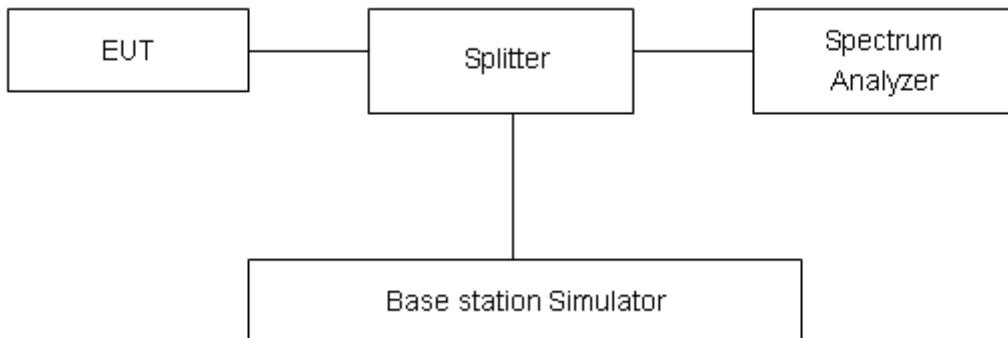

Limits

No specific occupied bandwidth requirements in part 2.1049.

Measurement Uncertainty

The assessed measurement uncertainty to ensure 95% confidence level for the normal distribution is with the coverage factor $k = 2$, $U=624\text{Hz}$.

Test Result



LTE Band 7						
RB	Modulation	Bandwidth (MHz)	Channel	Frequency (MHz)	99% Power Bandwidth(MHz)	-26dBc Bandwidth(MHz)
100%	QPSK	5	20775	2502.5	4.5146	5.193
			21100	2535	4.5062	5.189
			21425	2567.5	4.5152	5.114
		10	20800	2505	8.971	9.874
			21100	2535	9.0092	10.02
			21400	2565	9.0228	9.97
		15	20825	2507.5	13.462	14.89
			21100	2535	13.484	14.71
			21375	2562.5	13.461	14.91
		20	20850	2510	17.933	19.69
			21100	2535	17.972	19.84
			21350	2560	18.005	19.6
	16QAM	5	20775	2502.5	4.5259	5.202
			21100	2535	4.5064	5.255
			21425	2567.5	4.5163	5.119
		10	20800	2505	8.9912	9.862
			21100	2535	9.0151	9.927
			21400	2565	8.9663	9.922
		15	20825	2507.5	13.463	14.83
			21100	2535	13.476	14.95
			21375	2562.5	13.524	15.05
		20	20850	2510	17.963	19.61
			21100	2535	17.972	19.75
			21350	2560	17.939	19.45



LTE Band 7 QPSK 5MHz CH-Low



LTE Band 7 QPSK 10MHz CH-Low



LTE Band 7 QPSK 5MHz CH-Middle



LTE Band 7 QPSK 10MHz CH-Middle



LTE Band 7 QPSK 5MHz CH-High

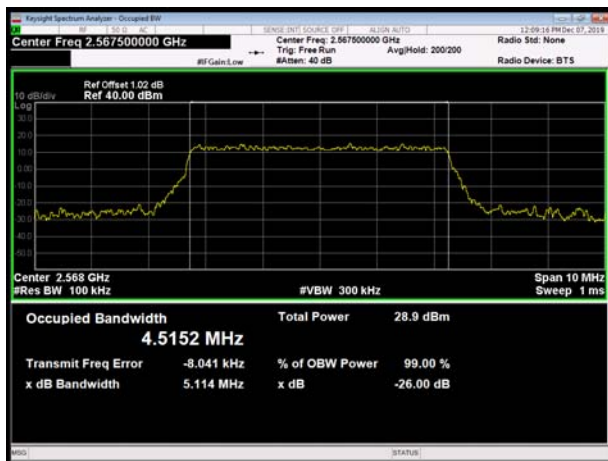

LTE Band 7 QPSK 10MHz CH-High

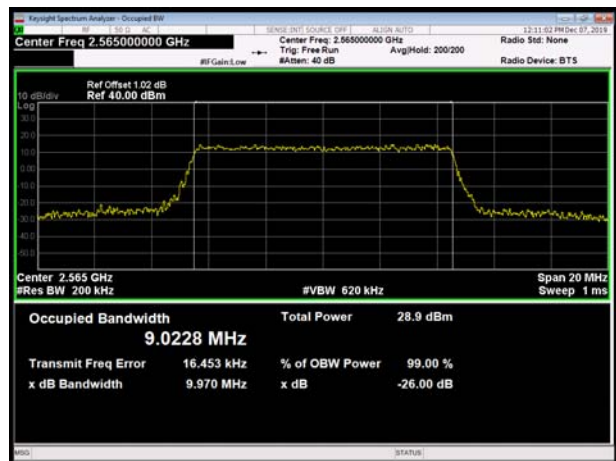



LTE Band 7 QPSK 15MHz CH-Low

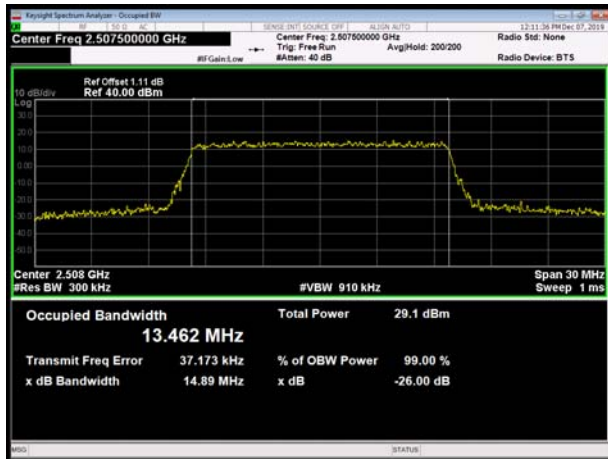

LTE Band 7 QPSK 20MHz CH-Low

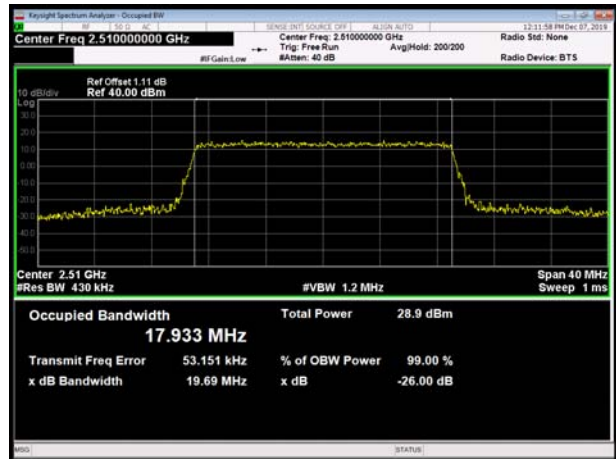

LTE Band 7 QPSK 15MHz CH-Middle

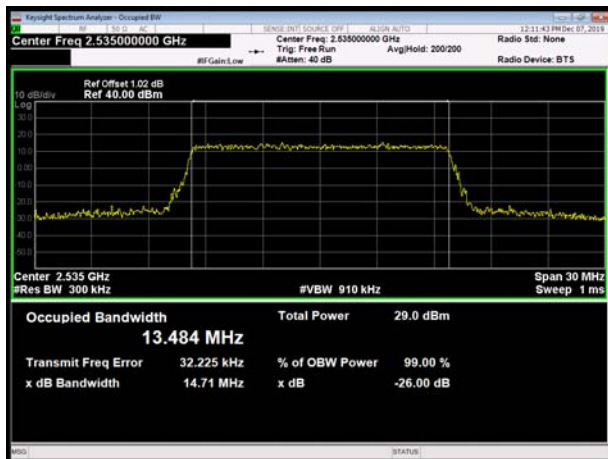

LTE Band 7 QPSK 20MHz CH-Middle

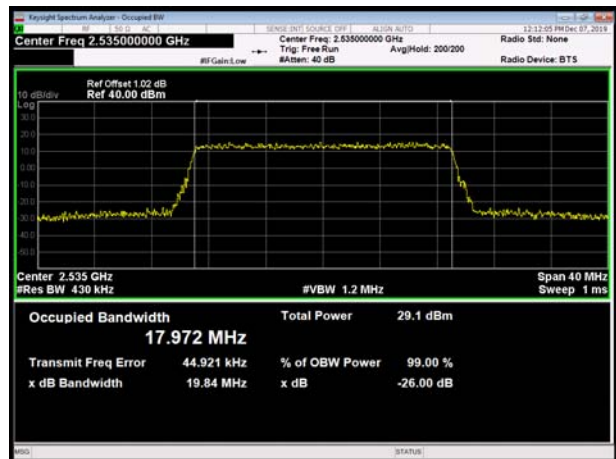

LTE Band 7 QPSK 15MHz CH-High

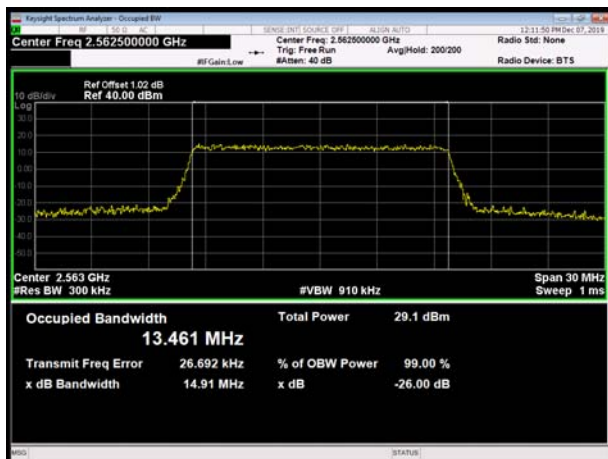

LTE Band 7 QPSK 20MHz CH-High

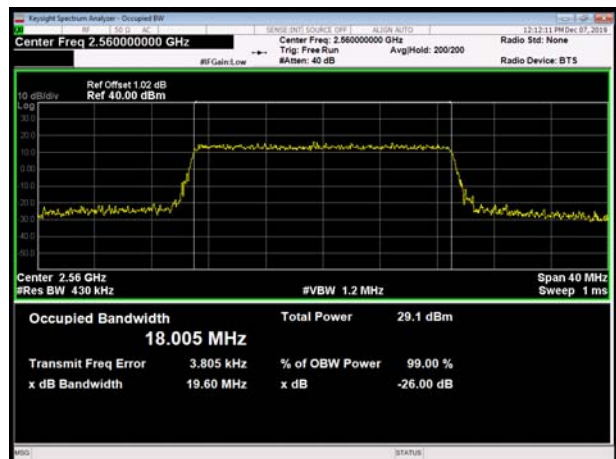



LTE Band 7 16QAM 5MHz CH-Low



LTE Band 7 16QAM 10MHz CH-Low

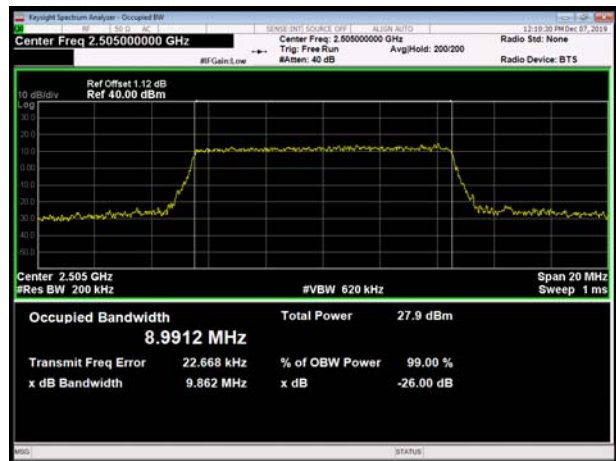

LTE Band 7 16QAM 5MHz CH-Middle

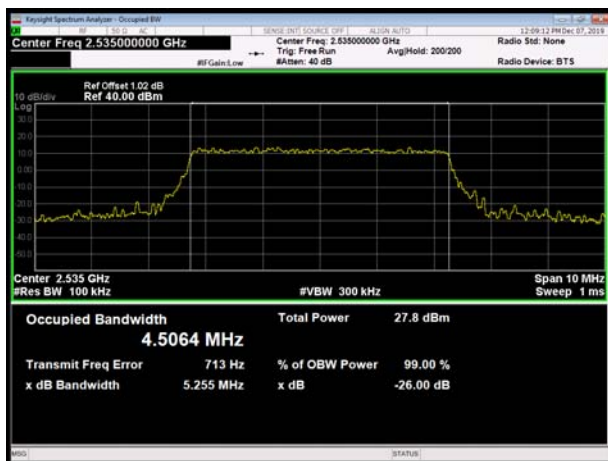

LTE Band 7 16QAM 10MHz CH-Middle

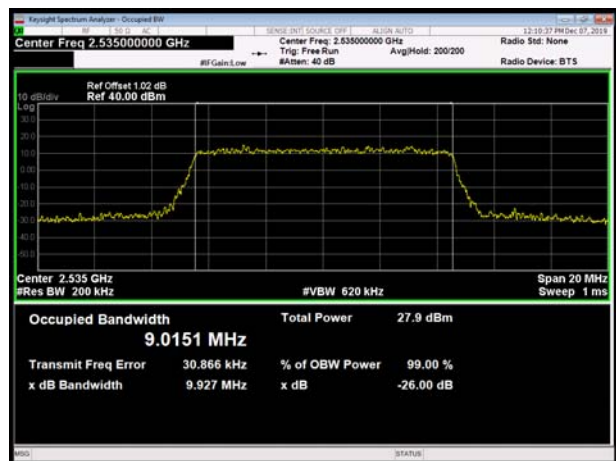

LTE Band 7 16QAM 5MHz CH-High



LTE Band 7 16QAM 10MHz CH-High

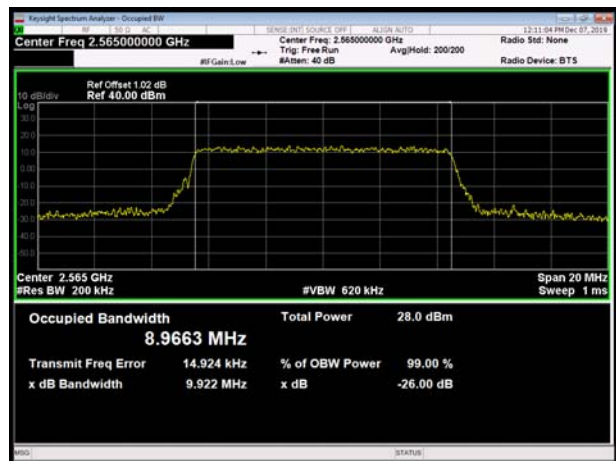



LTE Band 7 16QAM 15MHz CH-Low



LTE Band 7 16QAM 20MHz CH-Low

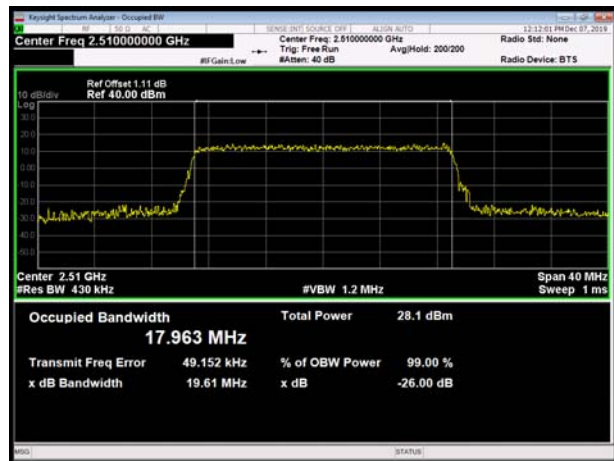

LTE Band 7 16QAM 15MHz CH-Middle



LTE Band 7 16QAM 20MHz CH-Middle

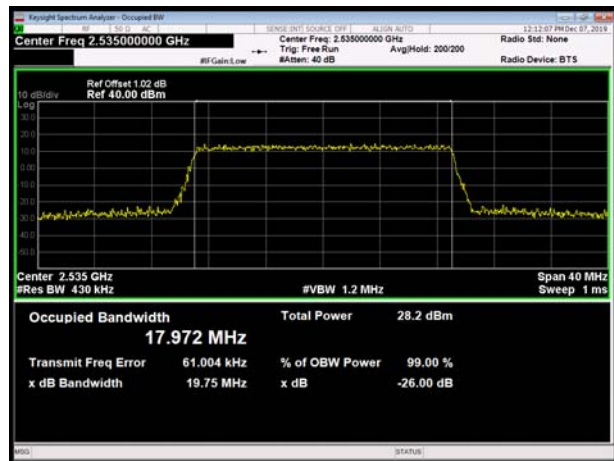

LTE Band 7 16QAM 15MHz CH-High

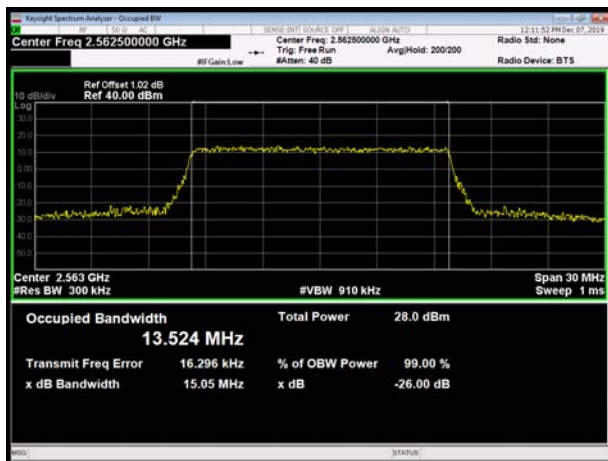

LTE Band 7 16QAM 20MHz CH-High

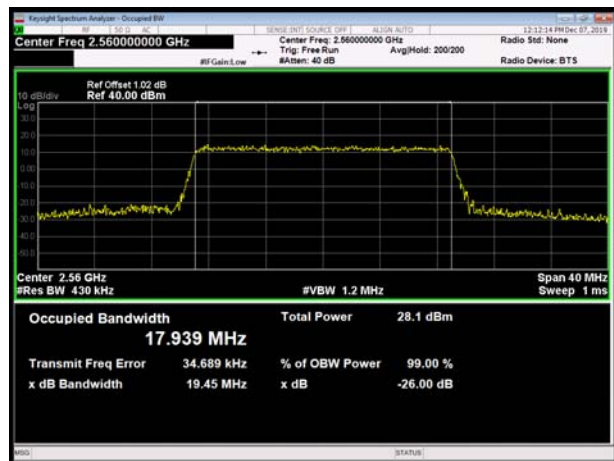

5.3 Band Edge Compliance

Ambient condition

Temperature	Relative humidity	Pressure
23°C ~25°C	45%~50%	101.5kPa

Method of Measurement

The EUT was connected to Spectrum Analyzer and Base Station Simulator via power Splitter. The band edge of the lowest and highest channels were measured.

The testing follows KDB 971168 D01 v03r01 Section 6.0

The EUT was connected to spectrum analyzer and system simulator via a power divider.

The band edges of low and high channels for the highest RF powers were measured.

RBW is set to 50 kHz, VBW is set to 200 kHz for LTE Band 7 (5MHz).

RBW is set to 100 kHz, VBW is set to 300kHz for LTE Band 7 (10MHz).

RBW is set to 200 kHz, VBW is set to 1MHz for LTE Band 7 (15MHz/20MHz).

on spectrum analyzer.

Set spectrum analyzer with RMS detector.

The RF fundamental frequency should be excluded against the limit line in the operating frequency band.

Checked that all the results comply with the emission limit line.

Test Setup

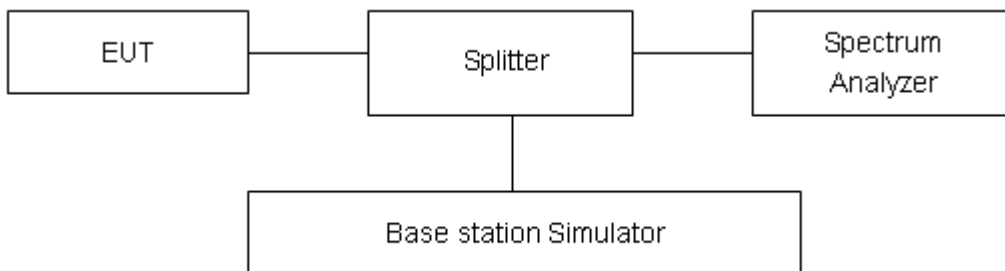

Limits

Rule Part 27.53(i) By a factor of not less than $43 + 10 \log (P)$ dB on all frequencies between 2305 and 2320 MHz.

Rule Part 27.53(m) (4)/ specifies that “for BRS and EBS stations. For mobile digital stations, the attenuation factor shall be not less than $40 + 10 \log (P)$ dB on all frequencies between the channel edge and 5 megahertz from the channel edge, $43 + 10 \log (P)$ dB on all frequencies between 5 megahertz and X megahertz from the channel edge, and $55 + 10 \log (P)$ dB on all frequencies more



than X megahertz from the channel edge, where X is the greater of 6 megahertz or the actual emission bandwidth as defined in paragraph (m)(4) of this section. In addition, the attenuation factor shall not be less than $43 + 10 \log (P)$ dB on all frequencies between 2490.5 MHz and 2496 MHz and $55 + 10 \log (P)$ dB at or below 2490.5 MHz. Mobile Satellite Service licensees operating on frequencies below 2495 MHz may also submit a documented interference complaint against BRS licensees operating on channel BRS Channel 1 on the same terms and conditions as adjacent channel BRS or EBS licensees.

Example:

The limit line is derived from $43 + 10 \log (P)$ dB below the transmitter power P(Watts)

$$= P(W) - [43 + 10 \log (P)] \text{ (dB)}$$

$$= [30 + 10 \log (P)] \text{ (dBm)} - [43 + 10 \log (P)] \text{ (dB)} = -13 \text{ dBm.}$$

Measurement Uncertainty

The assessed measurement uncertainty to ensure 95% confidence level for the normal distribution is with the coverage factor $k = 1.96$, $U = 0.684 \text{ dB}$.



Test Result

All the test traces in the plots shows the test results clearly.

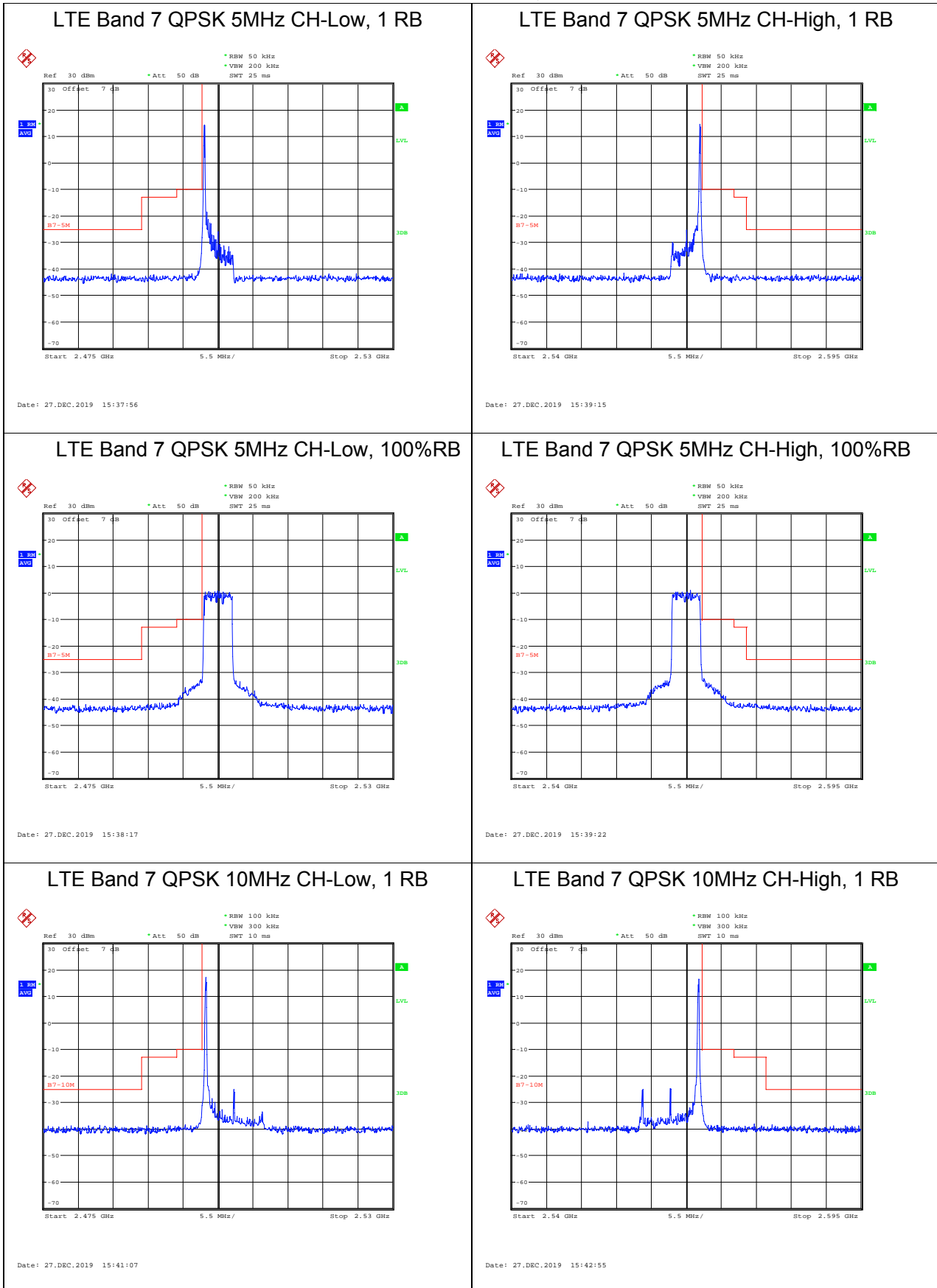



LTE Band 7 QPSK 10MHz CH-Low, 100%RB

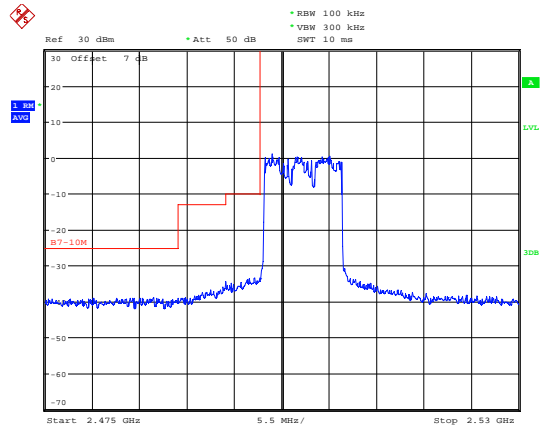

Date: 27.DEC.2019 15:41:26

LTE Band 7 QPSK 10MHz CH-High, 100%RB

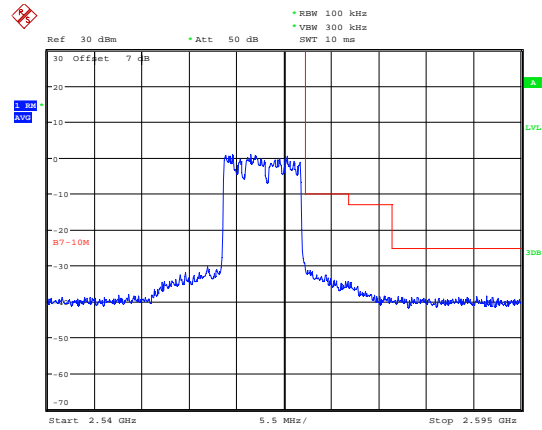

Date: 27.DEC.2019 15:44:43

LTE Band 7 QPSK 15MHz CH-Low, 1 RB

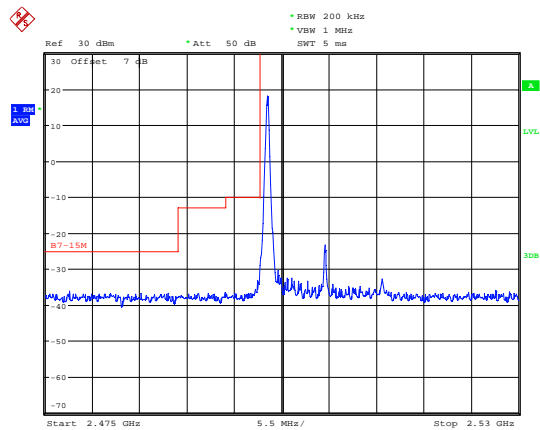

Date: 27.DEC.2019 15:49:04

LTE Band 7 QPSK 15MHz CH-High, 1 RB

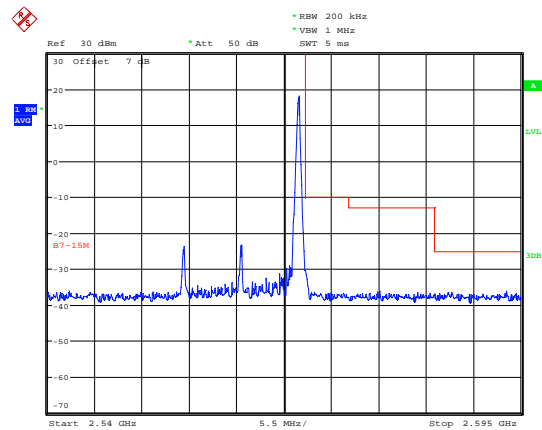

Date: 27.DEC.2019 15:49:55

LTE Band 7 QPSK 15MHz CH-Low, 100%RB

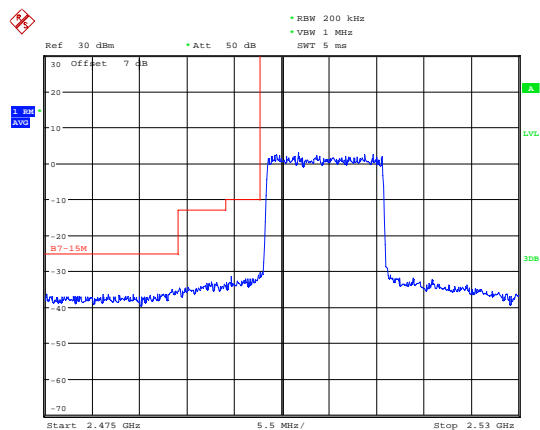

Date: 27.DEC.2019 15:49:12

LTE Band 7 QPSK 15MHz CH-High, 100%RB

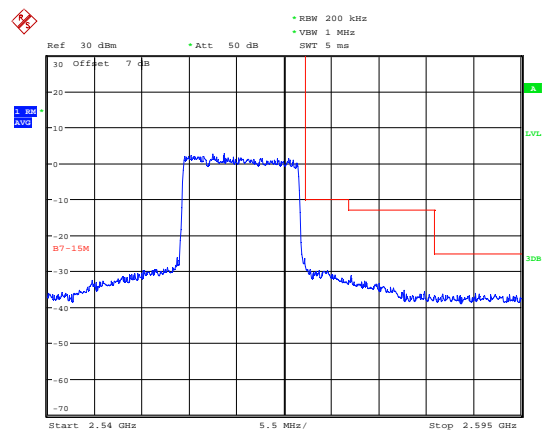

Date: 27.DEC.2019 15:50:17



LTE Band 7 QPSK 20MHz CH-Low, 1 RB

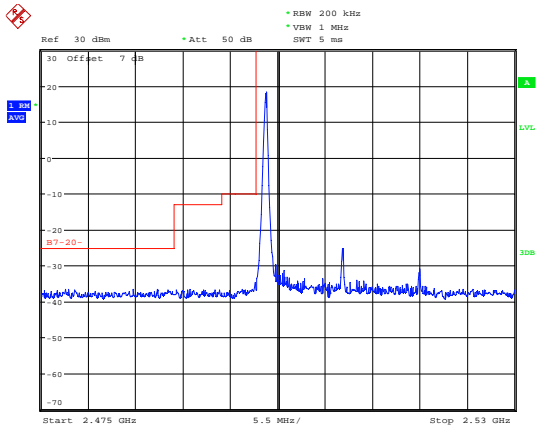

Date: 27.DEC.2019 15:51:30

LTE Band 7 QPSK 20MHz CH-High, 1 RB

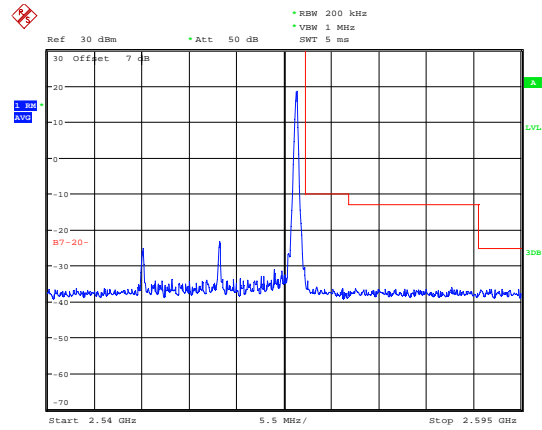

Date: 27.DEC.2019 15:52:24

LTE Band 7 QPSK 20MHz CH-Low, 100%RB

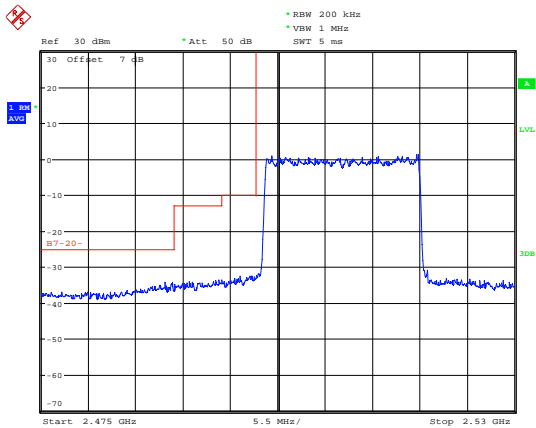

Date: 27.DEC.2019 15:51:36

LTE Band 7 QPSK 20MHz CH-High, 100%RB

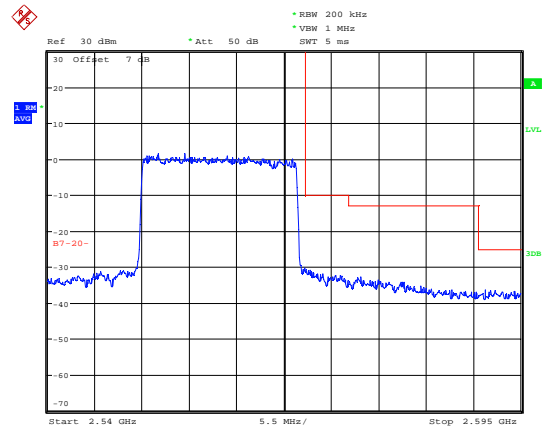

Date: 27.DEC.2019 15:52:31

LTE Band 7 16QAM 5MHz CH-Low, 1 RB

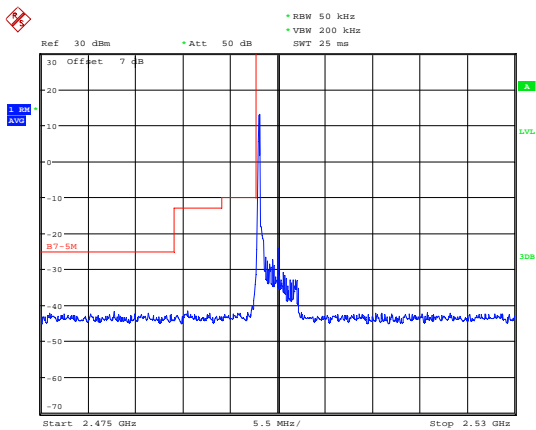

Date: 27.DEC.2019 15:38:25

LTE Band 7 16QAM 5MHz CH-High, 1 RB

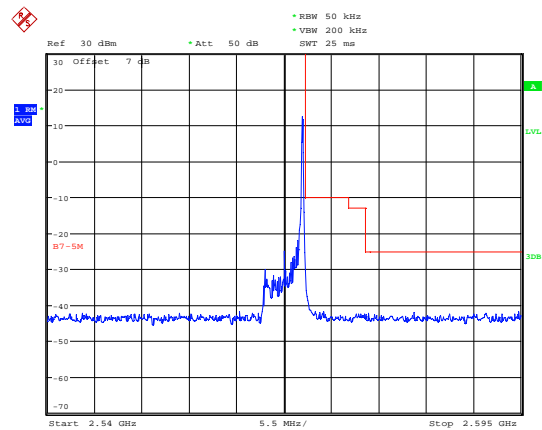

Date: 27.DEC.2019 15:39:31



LTE Band 7 16QAM 5MHz CH-Low, 100%RB

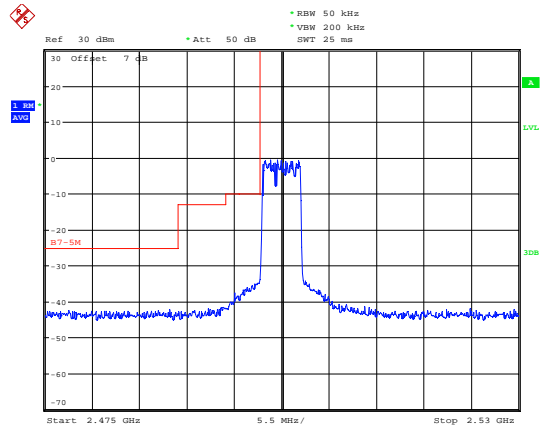

Date: 27.DEC.2019 15:38:33

LTE Band 7 16QAM 5MHz CH-High, 100%RB

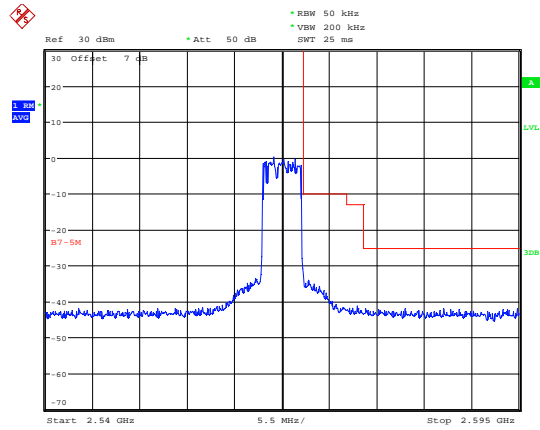

Date: 27.DEC.2019 15:39:39

LTE Band 7 16QAM 10MHz CH-Low, 1 RB

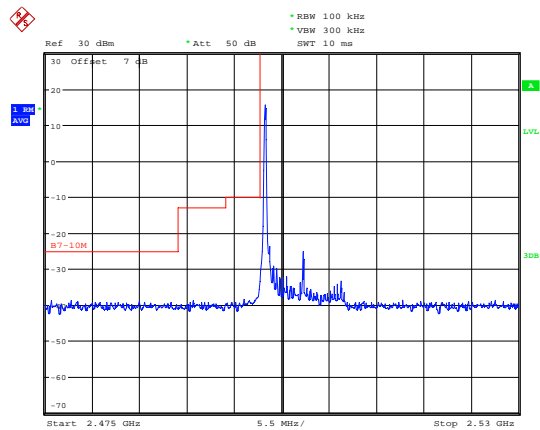

Date: 27.DEC.2019 15:41:37

LTE Band 7 16QAM 10MHz CH-High, 1 RB

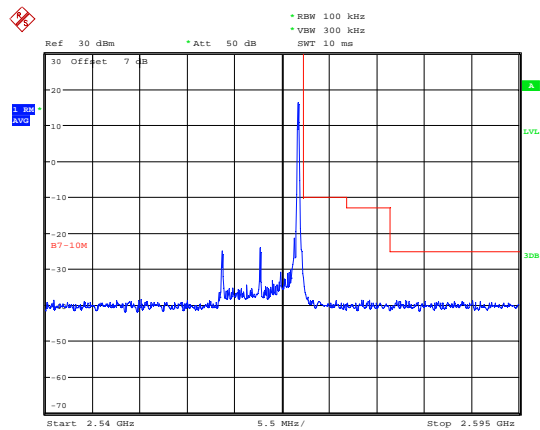

Date: 27.DEC.2019 15:43:34

LTE Band 7 16QAM 10MHz CH-Low, 100%RB

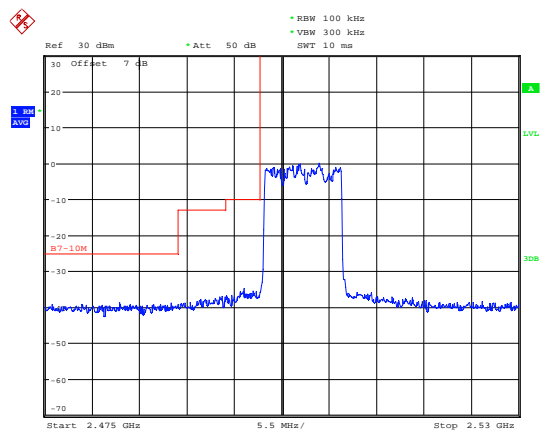

Date: 27.DEC.2019 15:41:49

LTE Band 7 16QAM 10MHz CH-High, 100%RB

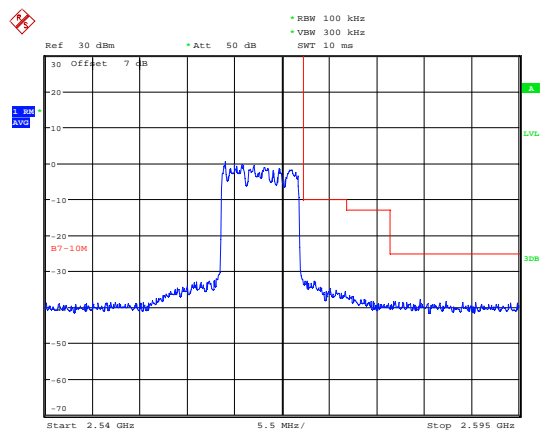

Date: 27.DEC.2019 15:43:42



LTE Band 7 16QAM 15MHz CH-Low, 1 RB

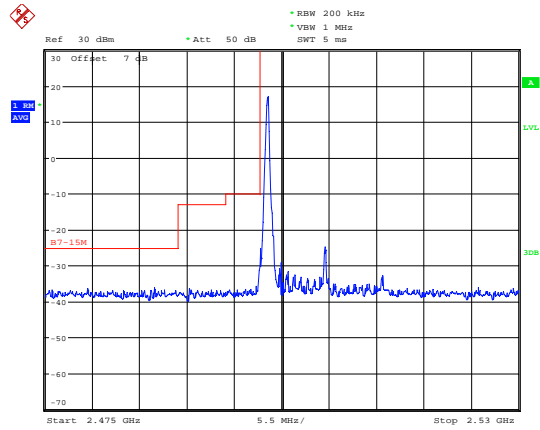

LTE Band 7 16QAM 15MHz CH-High, 1 RB

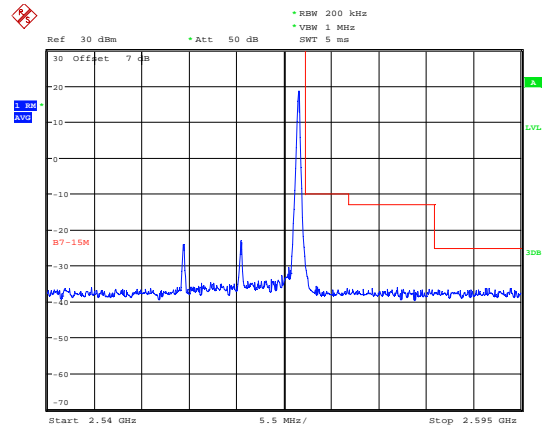

LTE Band 7 16QAM 15MHz CH-Low, 100%RB

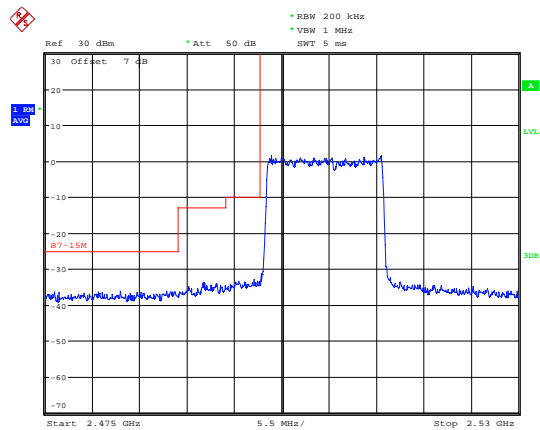

LTE Band 7 16QAM 15MHz CH-High, 100%RB

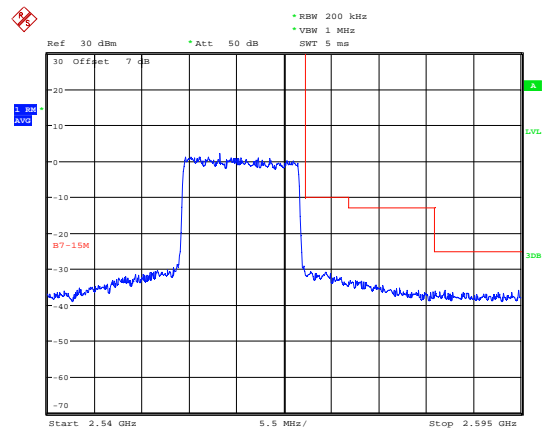

LTE Band 7 16QAM 20MHz CH-Low, 1 RB

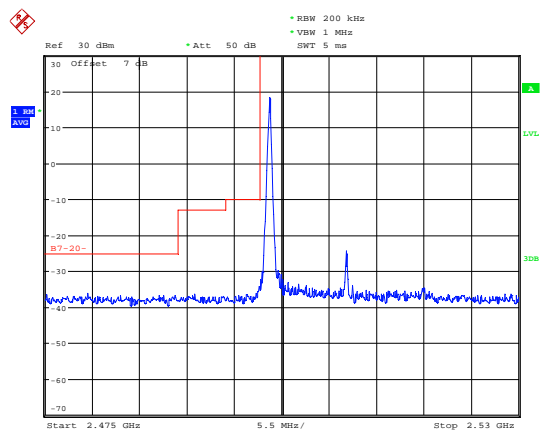

LTE Band 7 16QAM 20MHz CH-High, 1 RB

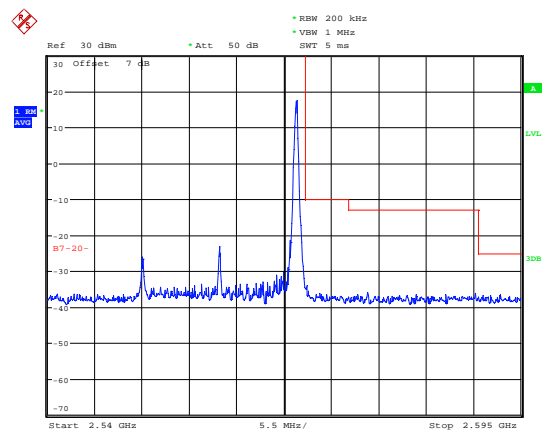



LTE Band 7 16QAM 20MHz CH-Low, 100%RB

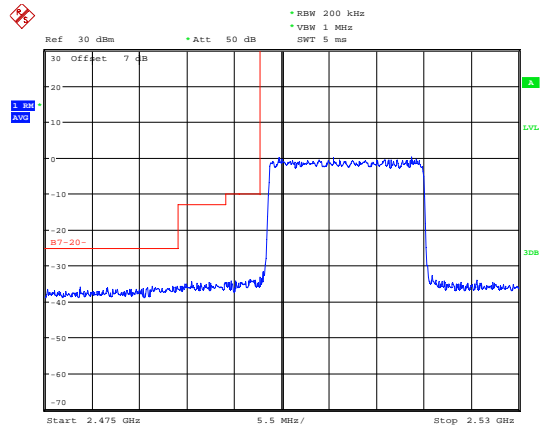

LTE Band 7 16QAM 20MHz CH-High, 100%RB

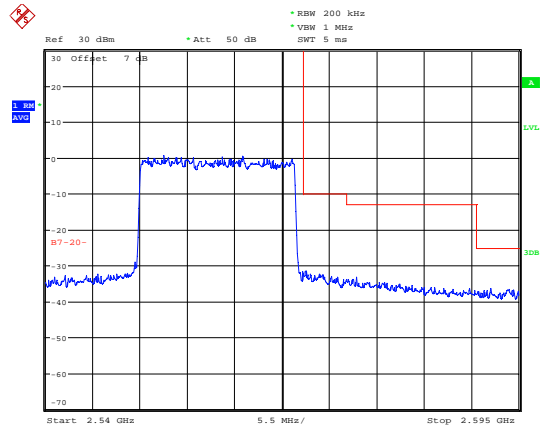

5.4 Peak-to-Average Power Ratio (PAPR)

Ambient condition

Temperature	Relative humidity	Pressure
23°C ~25°C	45%~50%	101.5kPa

Methods of Measurement

Measure the total peak power and record as PPk. And measure the total average power and record as PAvg. Both the peak and average power levels must be expressed in the same logarithmic units (e.g., dBm). Determine the PAPR from:

$$PAPR (dB) = PPk (dBm) - PAvg (dBm).$$

Test Setup

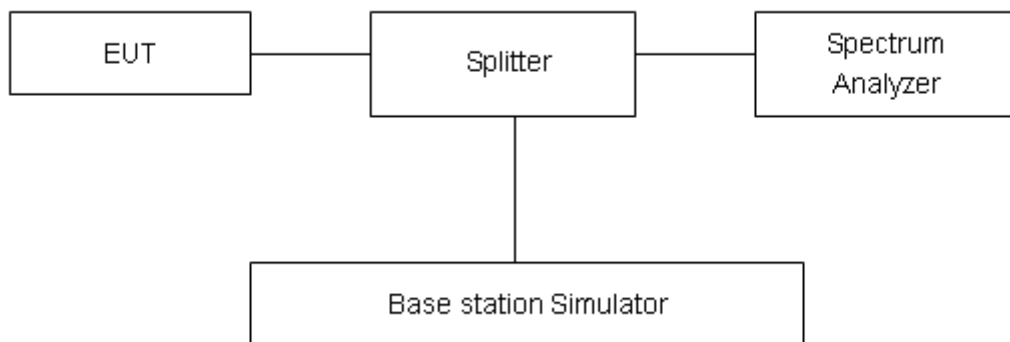

Limits

Rule Part 27.50(d)(5) Equipment employed must be authorized in accordance with the provisions of 24.51. Power measurements for transmissions by stations authorized under this section may be made either in accordance with a Commission-approved average power technique or in compliance with paragraph (d)(6) of this section. In measuring transmissions in this band using an average power technique, the peak-to-average ratio (PAR) of the transmission may not exceed 13 dB.

Measurement Uncertainty

The assessed measurement uncertainty to ensure 95% confidence level for the normal distribution is with the coverage factor k = 2, U= 0.4 dB.



Test Results

LTE Band 7								
Modulation	Bandwidth (MHz)	Channel	Frequency (MHz)	Peak (dBm)	Avg (dBm)	PAPR (dB)	Limit (dB)	Conclusion
QPSK	5	20775	2502.5	25.88	21.11	4.77	≤13	PASS
		21100	2535	26.31	21.10	5.21	≤13	PASS
		21425	2567.5	26.24	21.18	5.06	≤13	PASS
	10	20800	2505	25.95	21.09	4.86	≤13	PASS
		21100	2535	26.34	21.14	5.20	≤13	PASS
		21400	2565	26.26	21.21	5.05	≤13	PASS
	15	20825	2507.5	26.48	21.20	5.28	≤13	PASS
		21100	2535	26.78	21.21	5.57	≤13	PASS
		21375	2562.5	26.69	21.22	5.47	≤13	PASS
	20	20850	2510	26.33	21.01	5.32	≤13	PASS
		21100	2535	26.56	21.08	5.48	≤13	PASS
		21350	2560	26.51	21.15	5.36	≤13	PASS
16QAM	5	20775	2502.5	25.73	20.07	5.66	≤13	PASS
		21100	2535	26.09	20.08	6.01	≤13	PASS
		21425	2567.5	26.04	20.16	5.88	≤13	PASS
	10	20800	2505	25.78	20.08	5.70	≤13	PASS
		21100	2535	26.19	20.11	6.08	≤13	PASS
		21400	2565	26.09	20.17	5.92	≤13	PASS
	15	20825	2507.5	26.05	20.10	5.95	≤13	PASS
		21100	2535	26.36	20.14	6.22	≤13	PASS
		21375	2562.5	26.29	20.16	6.13	≤13	PASS
	20	20850	2510	26.13	20.01	6.12	≤13	PASS
		21100	2535	26.37	20.07	6.30	≤13	PASS
		21350	2560	26.25	20.12	6.13	≤13	PASS

5.5 Frequency Stability

Ambient condition

Temperature	Relative humidity	Pressure
23°C ~25°C	45%~50%	101.5kPa

Method of Measurement

Frequency Stability (Temperature Variation)

The temperature inside the climate chamber is varied from -30°C to +55°C in 10°C step size.

(1) With all power removed, the temperature was decreased to -10°C and permitted to stabilize for three hours.

(2) Measure the carrier frequency with the test equipment in a “call mode”. These measurements should be made within 1 minute of powering up the mobile station, to prevent significant self warming.

(3) Repeat the above measurements at 10°C increments from -30°C to +55°C. Allow at least 1.5 hours at each temperature, un-powered, before making measurements.

Frequency Stability (Voltage Variation)

The frequency stability shall be measured with variation of primary supply voltage as follows:

(1) Vary primary supply voltage from 85 to 115 percent of the nominal value for other than hand carried battery equipment.

(2) For hand carried, battery powered equipment, reduce primary supply voltage to the battery-operating end point which shall be specified by the manufacturer.

This transceiver is specified to operate with an input voltage of between 3.6 V and 4.35 V, with a nominal voltage of 3.8V.

Test setup

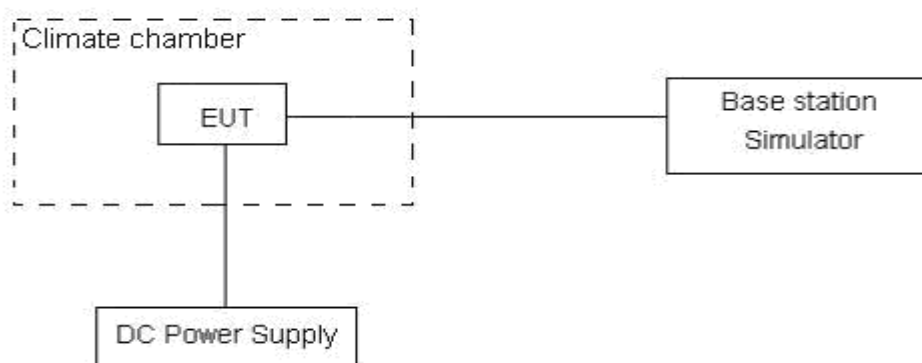

Limits

The frequency stability shall be sufficient to ensure that the fundamental emissions stay within the authorized bands of operation.

Measurement Uncertainty

The assessed measurement uncertainty to ensure 99.75% confidence level for the normal distribution is with the coverage factor $k = 3, U = 0.01\text{ppm}$.



Test Result

LTE Band 7						
Condition		Freq.Error (Hz)	Freq.Error (Hz)	Frequency Stability (ppm)	Frequency Stability (ppm)	Verdict
BANDWIDTH	5MHz					
Temperature	Voltage	16QAM	QPSK	16QAM	QPSK	
Normal (25°C)	Normal	9.61	2.65	0.00511	0.00141	PASS
Extreme (55°C)		13.45	13.77	0.00715	0.00732	PASS
Extreme (50°C)		1.70	16.70	0.00090	0.00888	PASS
Extreme (40°C)		13.22	2.83	0.00703	0.00150	PASS
Extreme (30°C)		1.39	5.86	0.00074	0.00312	PASS
Extreme (20°C)		6.33	13.25	0.00337	0.00705	PASS
Extreme (10°C)		13.72	12.59	0.00730	0.00670	PASS
Extreme (0°C)		17.96	17.34	0.00955	0.00923	PASS
Extreme (-10°C)		15.47	5.46	0.00823	0.00290	PASS
Extreme (-20°C)		14.83	13.39	0.00789	0.00712	PASS
Extreme (-30°C)		8.78	4.53	0.00467	0.00241	PASS
25°C		LV	12.03	17.22	0.00640	0.00916
	HV	1.28	6.97	0.00068	0.00371	PASS
Condition		Freq.Error (Hz)	Freq.Error (Hz)	Frequency Stability (ppm)	Frequency Stability (ppm)	Verdict
BANDWIDTH	10MHz					
Temperature	Voltage	16QAM	QPSK	16QAM	QPSK	
Normal (25°C)	Normal	10.19	11.66	0.00542	0.00620	PASS
Extreme (55°C)		17.23	16.90	0.00917	0.00899	PASS
Extreme (50°C)		15.84	4.41	0.00843	0.00234	PASS
Extreme (40°C)		5.94	7.39	0.00316	0.00393	PASS
Extreme (30°C)		2.98	17.74	0.00158	0.00943	PASS
Extreme (20°C)		13.96	14.07	0.00742	0.00748	PASS
Extreme (10°C)		4.81	8.11	0.00256	0.00431	PASS
Extreme (0°C)		13.20	11.51	0.00702	0.00612	PASS
Extreme (-10°C)		14.75	9.11	0.00784	0.00484	PASS
Extreme (-20°C)		8.23	4.55	0.00438	0.00242	PASS
Extreme (-30°C)		6.39	17.45	0.00340	0.00928	PASS
25°C		LV	10.13	8.76	0.00539	0.00466
	HV	12.37	1.21	0.00658	0.00064	PASS
Condition		Freq.Error (Hz)	Freq.Error (Hz)	Frequency Stability (ppm)	Frequency Stability (ppm)	Verdict
BANDWIDTH	15MHz					
Temperature	Voltage	16QAM	QPSK	16QAM	QPSK	
Normal (25°C)	Normal	7.96	14.54	0.00423	0.00774	PASS



Extreme (55°C)		6.83	17.67	0.00363	0.00940	PASS
Extreme (50°C)		10.71	1.82	0.00570	0.00097	PASS
Extreme (40°C)		13.37	6.65	0.00711	0.00353	PASS
Extreme (30°C)		17.62	11.29	0.00937	0.00601	PASS
Extreme (20°C)		14.34	8.63	0.00763	0.00459	PASS
Extreme (10°C)		16.07	16.36	0.00855	0.00870	PASS
Extreme (0°C)		3.08	5.37	0.00164	0.00286	PASS
Extreme (-10°C)		1.14	13.39	0.00061	0.00712	PASS
Extreme (-20°C)		10.24	1.40	0.00545	0.00075	PASS
Extreme (-30°C)		16.56	16.58	0.00881	0.00882	PASS
25°C	LV	12.48	10.11	0.00664	0.00538	PASS
	HV	10.49	8.51	0.00558	0.00453	PASS
Condition		Freq.Error (Hz)	Freq.Error (Hz)	Frequency Stability (ppm)	Frequency Stability (ppm)	Verdict
BANDWIDTH	20MHz					
Temperature	Voltage	16QAM	QPSK	16QAM	QPSK	
Normal (25°C)	Normal	12.92	16.51	0.00687	0.00878	PASS
Extreme (55°C)		4.10	6.58	0.00218	0.00350	PASS
Extreme (50°C)		10.21	13.84	0.00543	0.00736	PASS
Extreme (40°C)		1.41	15.44	0.00075	0.00821	PASS
Extreme (30°C)		11.52	17.96	0.00613	0.00955	PASS
Extreme (20°C)		14.84	3.87	0.00789	0.00206	PASS
Extreme (10°C)		4.67	14.77	0.00248	0.00786	PASS
Extreme (0°C)		12.35	12.42	0.00657	0.00660	PASS
Extreme (-10°C)		10.01	13.40	0.00532	0.00713	PASS
Extreme (-20°C)		1.93	5.24	0.00103	0.00279	PASS
Extreme (-30°C)		9.90	11.19	0.00527	0.00595	PASS
25°C	LV	12.37	11.47	0.00658	0.00610	PASS
	HV	1.76	4.17	0.00093	0.00222	PASS

5.6 Spurious Emissions at Antenna Terminals

Ambient condition

Temperature	Relative humidity	Pressure
23°C ~25°C	45%~50%	101.5kPa

Method of Measurement

The EUT was connected to Spectrum Analyzer and Base Station Simulator via power Splitter. The measurement is carried out using a spectrum analyzer. The spectrum analyzer scans from 9kHz to the 10th harmonic of the carrier. The peak detector is used.

RBW is set to 100kHz, VBW is set to 300kHz for 30MHz~1GHz

RBW is set to 1MHz, VBW is set to 3MHz for above 1GHz, Sweep is set to ATUO.

RBW is set to 1 kHz (0.009MHz~ 0.15 MHz),

RBW is set to 10 kHz (0.15 MHz~ 30 MHz)

RBW is set to 100 kHz (30MHz~1000 MHz)

RBW is set to 1000 kHz (above 1000MHz)

Of those disturbances below (limit – 20 dB), the mark is not required for the EUT.

The modulation mode and RB allocation refer to section 5.1, using the maximum output power configuration.

Test setup

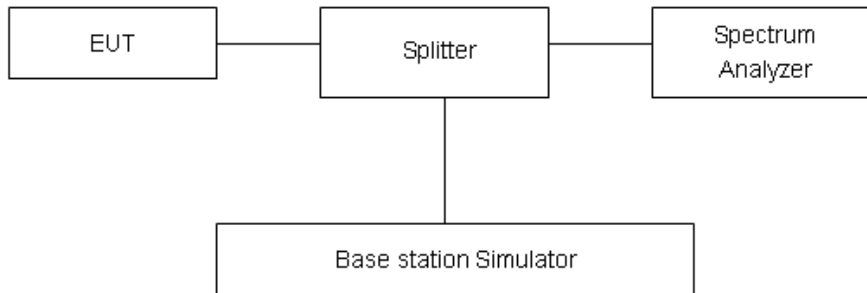

Limits

Rule Part 27.53(m) $55 + 10 \log (P)$ dB on all frequencies more than X megahertz from the channel edge, where X is the greater of 6 megahertz or the actual emission bandwidth as defined in paragraph (m)(4) of this section.

Part 27.53(m) Limit	-25 dBm
---------------------	---------

**Measurement Uncertainty**

The assessed measurement uncertainty to ensure 99.75% confidence level for the normal distribution is with the coverage factor $k = 1.96$.

Frequency	Uncertainty
9kHz-1GHz	0.684 dB
1GHz-27GHz	1.407 dB



Test Result

Sweep the whole frequency band through the range from 9kHz to the 10th harmonic of the carrier, the emissions more than 20 dB below the limit are not reported.

The signal beyond the limit is carrier.

LTE Band 7 5MHz CH- Low 9kHz~26GHz

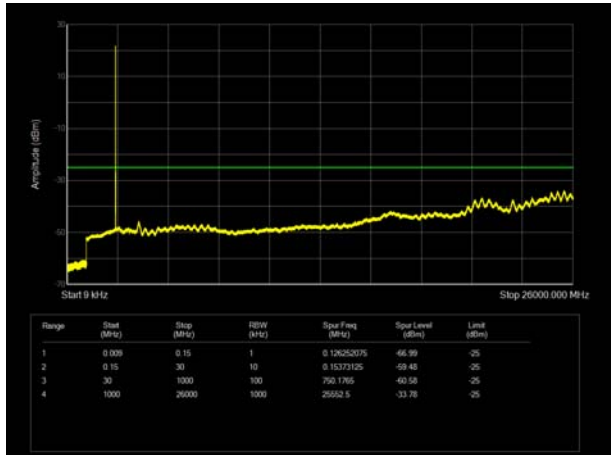

LTE Band 7 10MHz CH- Low 9kHz~26GHz

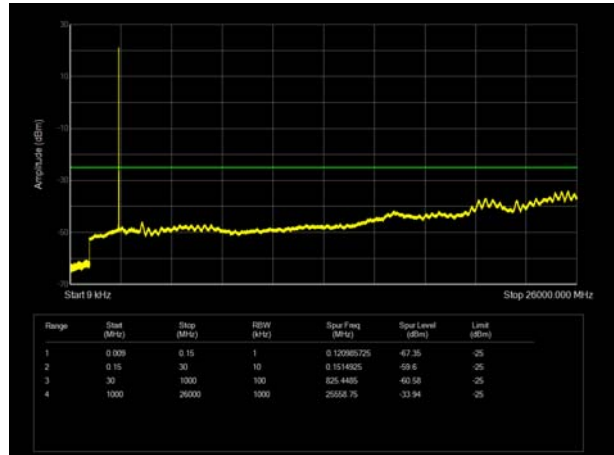

LTE Band 7 5MHz CH- Middle 9kHz~26GHz

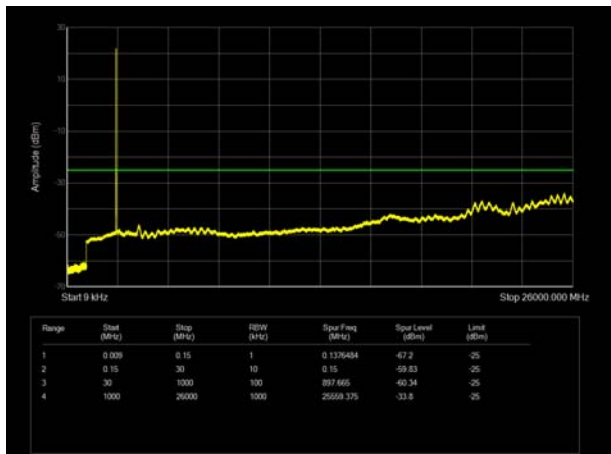

LTE Band 7 10MHz CH- Middle 9kHz~26GHz

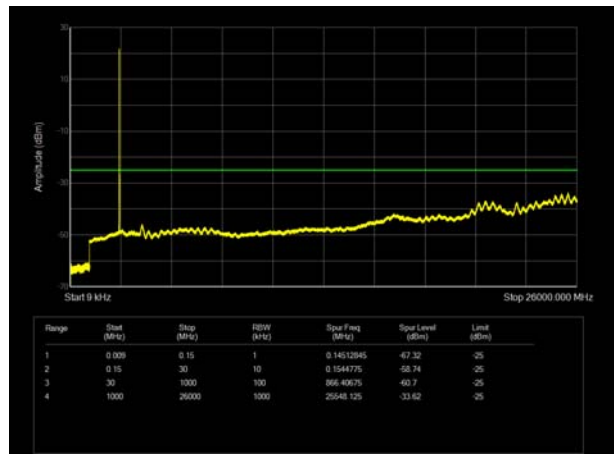

LTE Band 7 5MHz CH-High 9kHz~26GHz

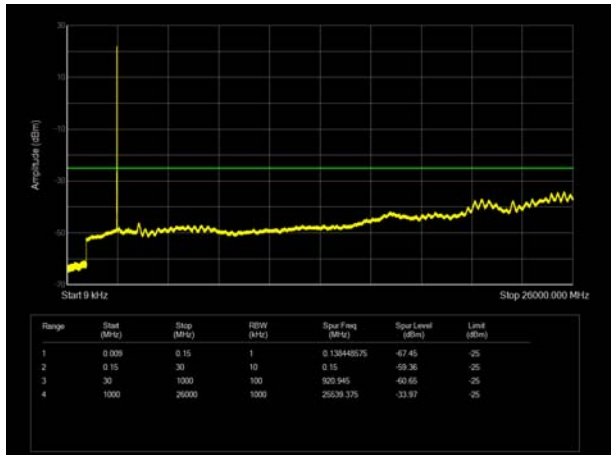

LTE Band 7 10MHz CH-High 9kHz~26GHz

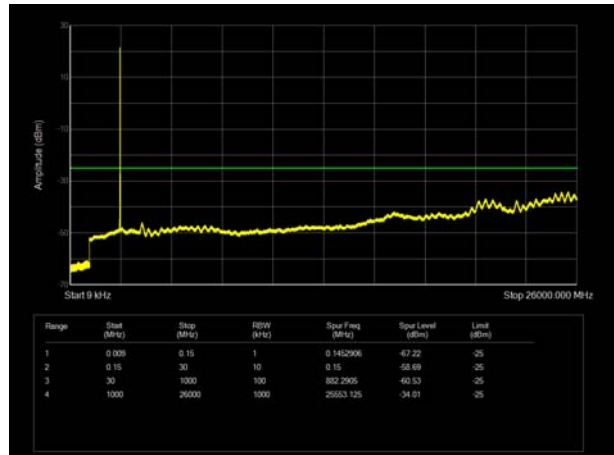



LTE Band 7 15MHz CH- Low 9kHz~26GHz

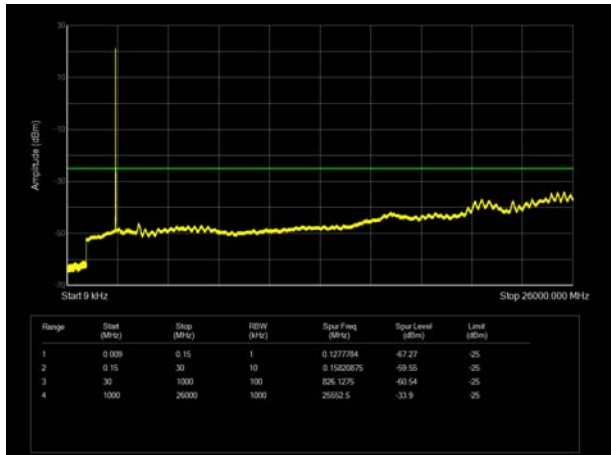

LTE Band 7 20MHz CH-Low 9kHz~26GHz

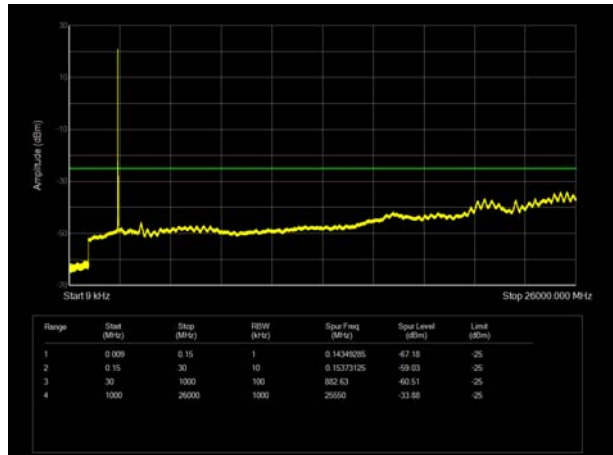

LTE Band 7 15MHz CH- Middle 9kHz~26GHz

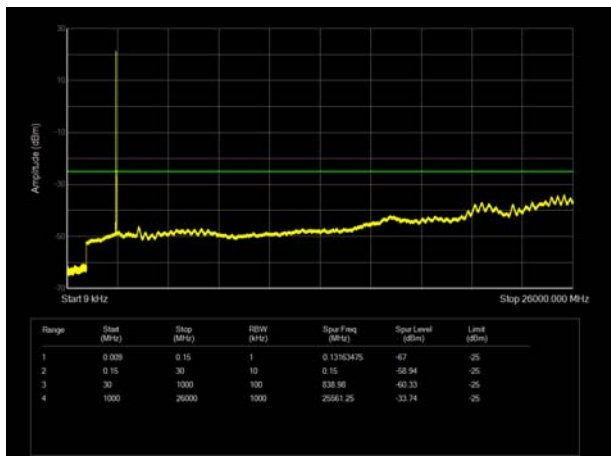

LTE Band 7 20MHz CH- Middle 9kHz~26GHz

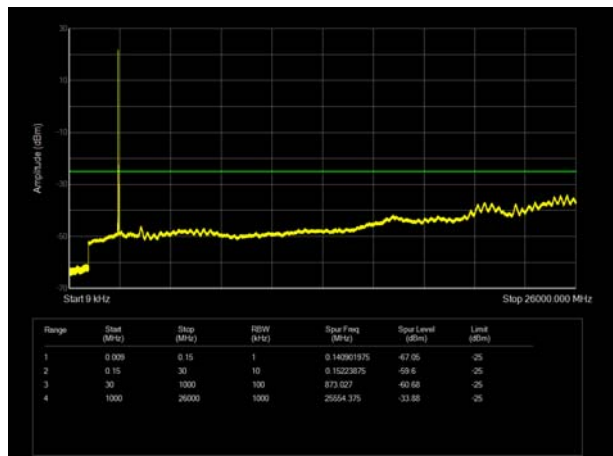

LTE Band 7 15MHz CH-High 9kHz~26GHz

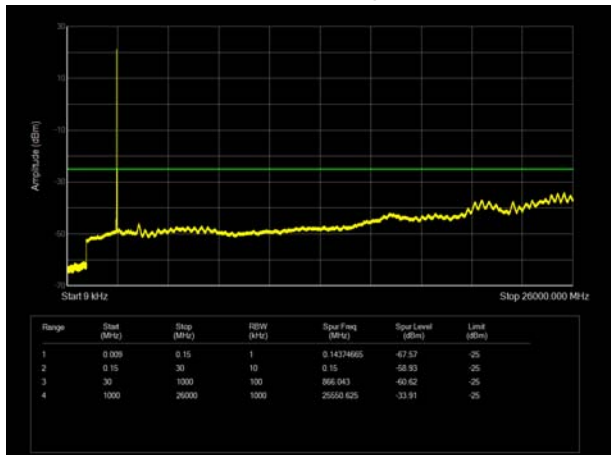

LTE Band 7 20MHz CH- High 9kHz~26GHz

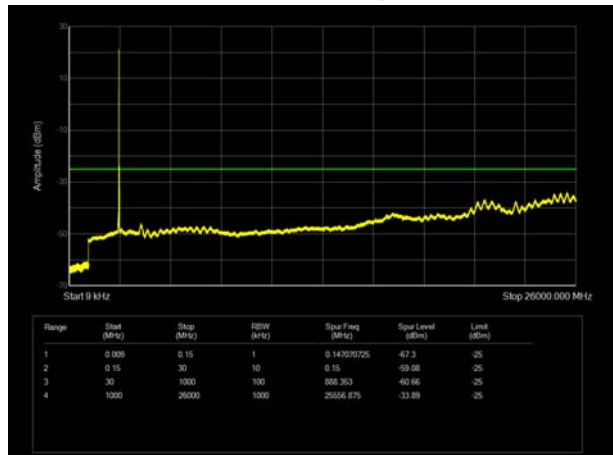

5.7 Radiates Spurious Emission

Ambient condition

Temperature	Relative humidity	Pressure
23°C ~25°C	45%~50%	101.5kPa

Method of Measurement

1. The testing follows FCC KDB 971168 D01 v03r01 Section 5.8 and ANSI C63.26 (2015).
2. Below 1GHz: The EUT is placed on a turntable 0.8 meters above the ground in the chamber, 3 meter away from the antenna. The maximal emission value is acquired by adjusting the antenna height, polarisation and turntable azimuth. Normally, the height range of antenna is 1 m to 4 m, the azimuth range of turntable is 0° to 360°, and the receive antenna has two polarizations Vertical (V) and Horizontal (H). Above 1GHz: (Note: the FCC's permission to use 1.5m as an alternative per TCBC Conf call of Dec. 2, 2014.) The EUT is placed on a turntable 1.5 meters above the ground in the chamber, 3 meter away from the antenna. The maximal emission value is acquired by adjusting the antenna height, polarisation and turntable azimuth. Normally, the height range of antenna is 1 m to 4 m, the azimuth range of turntable is 0° to 360°, and the receive antenna has two polarizations Vertical (V) and Horizontal (H).
3. A loop antenna, A log-periodic antenna or horn antenna shall be substituted in place of the EUT. The log-periodic antenna will be driven by a signal generator and the level will be adjusted till the same power value on the spectrum analyzer or receiver. The level of the spurious emissions can be calculated through the level of the signal generator, cable loss, the gain of the substitution antenna and the reading of the spectrum analyzer or receiver.
4. The EUT is then put into continuously transmitting mode at its maximum power level during the test. Set Test Receiver or Spectrum RBW=200Hz,VBW=600Hz for 9kHz150kHz , RBW=10kHz, VBW=30kHz 150kHz-30MHz ,RBW=100kHz,VBW=300kHz for 30MHz to 1GHz and RBW=1MHz, VBW=3MHz for above 1GHz And the maximum value of the receiver should be recorded as (Pr).
5. The EUT shall be replaced by a substitution antenna. In the chamber, an substitution antenna for the frequency band of interest is placed at the reference point of the chamber. An RF Signal source for the frequency band of interest is connected to the substitution antenna with a cable that has been constructed to not interfere with the radiation pattern of the antenna. A power (PMea) is applied to the input of the substitution antenna, and adjust the level of the signal generator output until the value of the receiver reach the previously recorded (Pr). The power of signal source (PMea) is recorded. The test should be performed by rotating the test item and adjusting the receiving antenna polarization.
6. A amplifier should be connected to the Signal Source output port. And the cable should be connect between the Amplifier and the Substitution Antenna. The cable loss (Pcl) ,the Substitution Antenna Gain (Ga) and the Amplifier Gain (PAg) should be recorded after test.
7. The measurement results are obtained as described below:
 $Power(EIRP)=PMea- PAg - Pcl + Ga$
 The measurement results are amend as described below:
 $Power(EIRP)=PMea- Pcl + Ga$
8. This value is EIRP since the measurement is calibrated using an antenna of known gain (2.15 dBi) and known input power. ERP can be calculated from EIRP by subtracting the gain of the dipole, ERP

= EIRP-2.15dBi.

The modulation mode and RB allocation refer to section 5.1, using the maximum output power configuration.

Test setup

9KHz ~ 30MHz

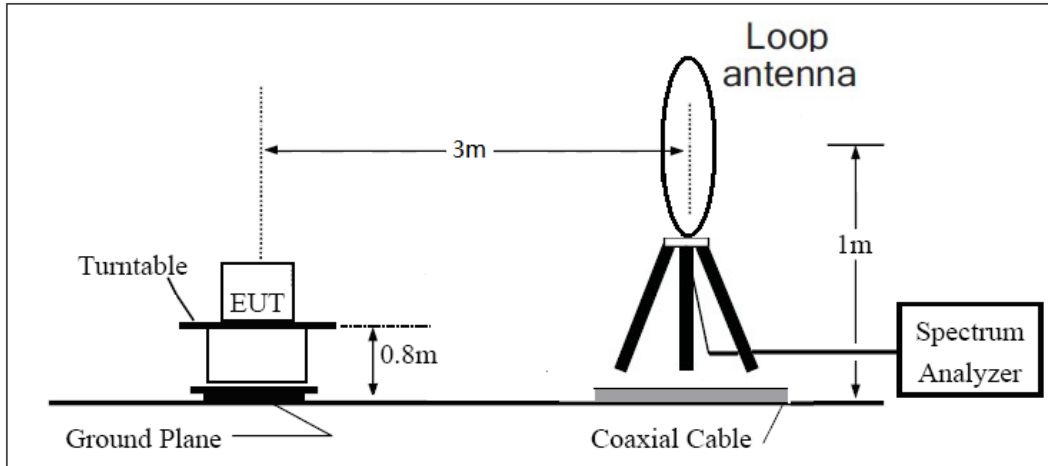

30MHz ~ 1GHz

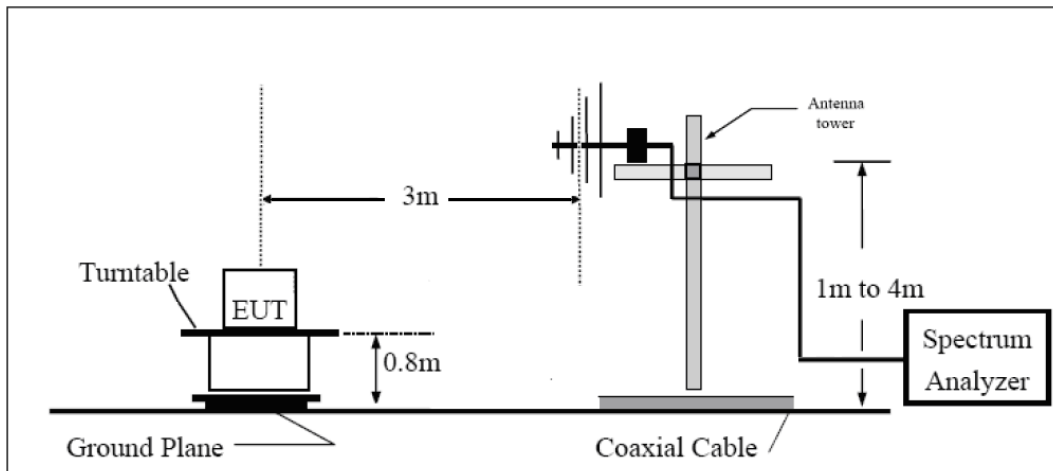

Above 1GHz

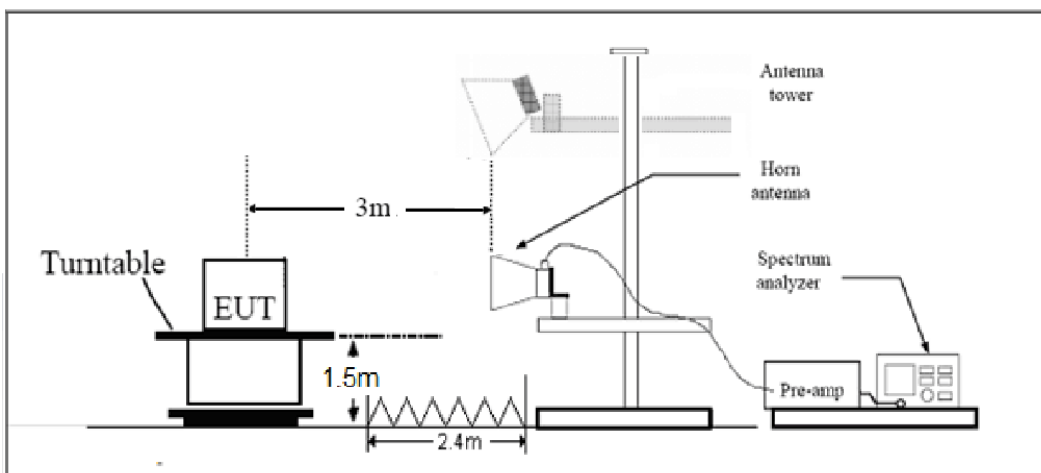

Note: Area side:2.4mX3.6m



Limits

Rule Part 27.53(m) $55 + 10 \log (P)$ dB on all frequencies more than X megahertz from the channel edge, where X is the greater of 6 megahertz or the actual emission bandwidth as defined in paragraph (m)(4) of this section.

Part 27.53(m) Limit	-25 dBm
---------------------	---------

Measurement Uncertainty

The assessed measurement uncertainty to ensure 95% confidence level for the normal distribution is with the coverage factor $k = \pm 1.96$, $U = \pm 3.55$ dB.

**Test Result**

Sweep the whole frequency band through the range from 9kHz to the 10th harmonic of the carrier, the emissions below the noise floor will not be recorded in the report.

LTE Band 7 QPSK 5MHz CH-Middle, RB 1

Harmonic	Frequency (MHz)	SG (dBm)	Cable Loss (dB)	Gain (dBi)	Antenna Polarization	EIRP Level (dBm)	Limit (dBm)	Margin (dB)	Azimuth (deg)
2	5065.8	-57.48	2.00	9.15	Horizontal	-50.33	-25.00	25.33	270
3	7598.6	-46.49	2.50	11.35	Horizontal	-37.64	-25.00	12.64	315
4	10130.6	-54.02	4.20	12.05	Horizontal	-46.17	-25.00	21.17	180
5	12675.0	-49.96	5.20	12.85	Horizontal	-42.31	-25.00	17.31	90
6	15210.0	-51.30	5.50	14.23	Horizontal	-42.57	-25.00	17.57	135
7	17745.0	-49.34	5.70	14.15	Horizontal	-40.89	-25.00	15.89	270
8	20280.0	--	--	--	--	--	--	--	--
9	22815.0	--	--	--	--	--	--	--	--
10	25350.0	--	--	--	--	--	--	--	--

Note: 1.The other Spurious RF Radiated emissions level is no more than noise floor.

2. The worst emission was found in the antenna is Horizontal position.

LTE Band 7 QPSK 20MHz CH-Middle, RB 1

Harmonic	Frequency (MHz)	SG (dBm)	Cable Loss (dB)	Gain (dBi)	Antenna Polarization	EIRP Level (dBm)	Limit (dBm)	Margin (dB)	Azimuth (deg)
2	5052.4	-59.19	2.00	10.15	Horizontal	-51.04	-25.00	26.04	315
3	7578.0	-45.79	2.50	11.35	Horizontal	-36.94	-25.00	11.94	225
4	10103.6	-54.52	4.20	12.05	Horizontal	-46.67	-25.00	21.67	135
5	12629.3	-52.67	5.20	14.85	Horizontal	-43.02	-25.00	18.02	0
6	15154.9	-52.25	5.50	13.23	Horizontal	-44.52	-25.00	19.52	180
7	17680.5	-48.68	5.70	12.15	Horizontal	-42.23	-25.00	17.23	315
8	20206.1	--	--	--	--	--	--	--	--
9	22731.8	--	--	--	--	--	--	--	--
10	25257.4	--	--	--	--	--	--	--	--

Note: 1.The other Spurious RF Radiated emissions level is no more than noise floor.

2. The worst emission was found in the antenna is Horizontal position.



6 Main Test Instruments

Name	Manufacturer	Type	Serial Number	Calibration Date	Expiration Date
Base Station Simulator	R&S	CMW500	113824	2019-05-19	2020-05-18
Power Splitter	Hua Xiang	SHX-GF2-2-13	10120101	/	/
Spectrum Analyzer	Key sight	N9010A	MY50210259	2019-05-19	2020-05-18
Signal Analyzer	R&S	FSV30	100815	2019-12-15	2020-12-14
Loop Antenna	SCHWARZBECK	FMZB1519	1519-047	2017-09-26	2020-09-25
Trilog Antenna	SCHWARZBECK	VUBL 9163	9163-201	2017-11-18	2020-11-17
Horn Antenna	R&S	HF907	100126	2018-07-07	2020-07-06
Horn Antenna	ETS-Lindgren	3160-09	00102643	2018-06-20	2020-06-19
Signal generator	R&S	SMB 100A	102594	2019-05-19	2020-05-18
Climatic Chamber	ESPEC	SU-242	93000506	2017-12-17	2020-12-16
Preamplifier	R&S	SCU18	102327	2019-05-19	2020-05-18
MOB COMMS DC SUPPLY	Keysight	66319D	MY43004105	2019-05-19	2020-05-18
RF Cable	Agilent	SMA 15cm	0001	2019-12-13	2020-06-12
Software	R&S	EMC32	9.26.0	/	/

*****END OF REPORT *****