



TEST REPORT

No. I17D00046-SAR

For

Client: Mobiwire SAS

Production: 3G SmartPhone

Model Name: MobiWire Kwanita, Orange Rise 33

FCC ID: QPN-KWANITA

Hardware Version: V03

Software Version: V01

Issued date: 2017-5-26

Note:

The test results in this test report relate only to the devices specified in this report. This report shall not be reproduced except in full without the written approval of ECIT Shanghai.

Test Laboratory:

ECIT Shanghai, East China Institute of Telecommunications

Add: 7-8F, G Area, No.668, Beijing East Road, Huangpu District, Shanghai, P. R. China

Tel: (+86)-021-63843300, E-Mail: welcome@ecit.org.cn

Revision Version

Report Number	Revision	Date	Memo
I17D00046-SAR	00	2017-5-12	Initial creation of test report
I17D00046-SAR	01	2017-5-25	Second creation of test report
I17D00046-SAR	02	2017-5-26	Third creation of test report

CONTENTS

1.	TEST LABORATORY.....	6
1.1.	TESTING LOCATION.....	6
1.2.	TESTING ENVIRONMENT	6
1.3.	PROJECT DATA	6
1.4.	SIGNATURE	6
2.	STATEMENT OF COMPLIANCE.....	7
3.	CLIENT INFORMATION.....	9
3.1.	APPLICANT INFORMATION.....	9
3.2.	MANUFACTURER INFORMATION.....	9
4.	EQUIPMENT UNDER TEST (EUT) AND ANCILLARY EQUIPMENT (AE).....	10
4.1.	ABOUT EUT	10
4.2.	INTERNAL IDENTIFICATION OF EUT USED DURING THE TEST	11
4.3.	INTERNAL IDENTIFICATION OF AE USED DURING THE TEST.....	11
5.	TEST METHODOLOGY	12
5.1.	APPLICABLE LIMIT REGULATIONS	12
5.2.	APPLICABLE MEASUREMENT STANDARDS.....	12
6.	SPECIFIC ABSORPTION RATE (SAR)	13
6.1.	INTRODUCTION	13
6.2.	SAR DEFINITION.....	13
7.	TISSUE SIMULATING LIQUIDS.....	14
7.1.	TARGETS FOR TISSUE SIMULATING LIQUID	14
7.2.	DIELECTRIC PERFORMANCE.....	14
8.	SYSTEM VERIFICATION.....	16
8.1.	SYSTEM SETUP	16
8.2.	SYSTEM VERIFICATION.....	17

9.	MEASUREMENT PROCEDURES.....	19
9.1.	TESTS TO BE PERFORMED.....	19
9.2.	GENERAL MEASUREMENT PROCEDURE.....	20
9.3.	BLUETOOTH & WI-FI MEASUREMENT PROCEDURES FOR SAR	22
9.4.	POWER DRIFT.....	22
10.	AREA SCAN BASED 1-G SAR	23
11.	CONDUCTED OUTPUT POWER	24
11.1.	MANUFACTURING TOLERANCE	24
11.2.	GSM MEASUREMENT RESULT	26
11.3.	WI-FI AND BT MEASUREMENT RESULT.....	27
12.	SIMULTANEOUS TX SAR CONSIDERATIONS	30
12.1.	INTRODUCTION	30
12.2.	TRANSMIT ANTENNA SEPARATION DISTANCES.....	30
12.3.	STANDALONE SAR TEST EXCLUSION CONSIDERATIONS.....	31
12.4.	SAR MEASUREMENT POSITIONS	31
13.	EVALUATION OF SIMULTANEOUS	32
14.	SAR TEST RESULT.....	34
15.	SAR MEASUREMENT VARIABILITY	39
16.	MEASUREMENT UNCERTAINTY.....	40
17.	MAIN TEST INSTRUMENT.....	41
ANNEX A.	GRAPH RESULTS.....	42
ANNEX B.	SYSTEM VALIDATION RESULTS	51
ANNEX C.	SAR MEASUREMENT SETUP	57
ANNEX D.	POSITION OF THE WIRELESS DEVICE IN RELATION TO THE PHANTOM.....	66
ANNEX E.	EQUIVALENT MEDIA RECIPES	70
ANNEX F.	SYSTEM VALIDATION	71

ANNEX G. PROBE AND DAE CALIBRATION CERTIFICATE..... 72

ANNEX H. ACCREDITATION CERTIFICATE 121

1. Test Laboratory

1.1. Testing Location

Company Name:	ECIT Shanghai, East China Institute of Telecommunications
Address:	7-8F, G Area, No. 668, Beijing East Road, Huangpu District, Shanghai, P. R. China
Postal Code:	200001
Telephone:	(+86)-021-63843300
Fax:	(+86)-021-63843301

1.2. Testing Environment

Normal Temperature:	18-25°C
Relative Humidity:	30-70%
Ambient noise & Reflection:	< 0.012 W/kg

1.3. Project Data

Project Leader:	Yu Anlu
Testing Start Date:	2017-4-12
Testing End Date:	2017-4-13

1.4. Signature



Yan Hang
(Prepared this test report)



Song Kaihua
(Reviewed this test report)

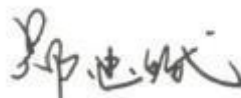

Zheng Zhongbin
Director of the laboratory
(Approved this test report)

2. Statement of Compliance

The maximum results of Specific Absorption Rate (SAR) found during testing for **MobiWire Kwanita, Orange Rise 33** are as follows (with expanded uncertainty 22.4%)

Table 2.1: Max. Reported SAR (1g)

Band	Position/Distance	SAR 1g (W/Kg)
GSM 850	Head	0.352
	Body/10mm	0.862
GSM 1900	Head	0.967
	Body/10mm	0.924
Wi-Fi	Head	0.671
	Body/10mm	0.371

Table 2.2: The maximum of SAR values

	Maximum SAR value for Head	Maximum SAR value for Body
GSM	0.967	0.924
WIFI	0.671	0.317

The SAR values found for the Mobile Phone are below the maximum recommended levels of 1.6 W/Kg as averaged over any 1g tissue according to the ANSI C95.1-1999.

For body worn operation, this device has been tested and meets FCC RF exposure guidelines when used with any accessory that contains no metal. Use of other accessories may not ensure compliance with FCC RF exposure guidelines.

The sample has two antennas. One is main antenna for GSM, and the other is for WiFi/BT. So simultaneous transmission is GSM and WiFi/BT.

Table 2.3: Simultaneous SAR (1g)

Transmission SAR(W/Kg)						
Test Position		2G	WIFI	BT	SUM	
Head	Left	Cheek	0.967	0.180	0.066	1.147
		Tilt 15°	0.164	0.060	0.066	0.230
	Right	Cheek	0.401	0.671	0.066	1.072
		Tilt 15°	0.194	0.375	0.066	0.569
Hotspot 10mm	Phantom Side		0.678	0.317	0.033	0.995
	Ground Side		0.924	0.264	0.033	1.188
	Left Side		0.664	0.036	0.033	0.700
	Right Side		0.519	0.041	0.033	0.560
	Bottom Side		0.355	--	0.033	0.355
	Top Side		--	0.227	0.033	0.227

According to the above table, the maximum sum of reported SAR values for GSM and WiFi is **1.188 W/kg** (1g). The detail for simultaneous transmission consideration is described in chapter 12.

3. Client Information

3.1. Applicant Information

Company Name: Mobiwire SAS
Address: 79 AVENUE FRANCOIS ARAGO 92017 NANTERRE CEDEX France.
Email: alexandre.minazio@mobiwire.com
Contact: Alexandre Minazio

3.2. Manufacturer Information

Company Name: MOBIWIRE MOBILES (NINGBO) CO.,LTD
Address: No.999,Dacheng East Road,Fenghua City,Zhejiang
Email: Hongdou.hu@mobiwire.com.cn
Contact: Hu hongdou

4. Equipment Under Test (EUT) and Ancillary Equipment (AE)

4.1. About EUT

Description:	3G SmartPhone
Model name:	MobiWire Kwanita, Orange Rise 33
Operation Model(s):	GSM850/1900,WIFI2450
Tx Frequency:	824.2-848.8MHz(GSM850) 1850.2-1909.8MHz (GSM1900) 2412- 2462 MHz (Wi-Fi) 2400-2483.5 MHz (BT)
Test device Production information: GPRS/EGPRS Class Mode: GPRS/ EGPRS Multislot Class:	Production unit B 12 N/A
Device type:	Portable device
UE category:	3
Antenna type:	Inner antenna
Accessories/Body-worn configurations:	Headset Battery
Dimensions: Hotspot Mode:	12.5cm×6.5cm×1.0cm Support simultaneous transmission of hotspot and voice (or data)
FCC ID:	QPN-KWANITA

4.2. Internal Identification of EUT used during the test

EUT ID*	SN or IMEI	HW Version	SW Version	Receive Date
N06	356422080004290	V03	V01	2017-03-23

*EUT ID: is used to identify the test sample in the lab internally.

4.3. Internal Identification of AE used during the test

AE ID*	Description	Model	SN	Manufacturer
A02	Headset	N/A	N/A	N/A
B03	Battery	N/A	19744V6122700286	MobiWire

*AE ID: is used to identify the test sample in the lab internally.

5. TEST METHODOLOGY

5.1. Applicable Limit Regulations

ANSI C95.1–1999:IEEE Standard for Safety Levels with Respect to Human Exposure to Radio Frequency Electromagnetic Fields, 3 kHz to 300 GHz.

It specifies the maximum exposure limit of **1.6 W/kg** as averaged over any 1 gram of tissue for portable devices being used within 20 cm of the user in the uncontrolled environment.

5.2. Applicable Measurement Standards

IEEE 1528–2013: Recommended Practice for Determining the Peak Spatial-Average Specific Absorption Rate (SAR) in the Human Body Due to Wireless Communications Devices: Experimental Techniques.

KDB648474 D04 Handset SAR v01r03:SAR Evaluation Considerations for Wireless Handsets.

KDB248227 D01 802.11 Wi-Fi SAR v02r02: SAR measurement procedures for 802.112abg transmitters.

KDB447498 D01 General RF Exposure Guidance v06:Mobile and Portable Devices RF Exposure Procedures and Equipment Authorization Policies.

KDB865664 D01 SAR Measurement 100 MHz to 6 GHz v01r04:SAR Measurement Requirements for 100 MHz to 6 GHz

KDB865664 D02 RF Exposure Reporting v01r02:provides general reporting requirements as well as certain specific information required to support MPE and SAR compliance.

KDB941225 D06 hotspot SAR v02r01:SAR Evaluation Procedures for Portable Devices with Wireless Router Capabilities.

NOTE: KDB is not in A2LA Scope List.

6. Specific Absorption Rate (SAR)

6.1. Introduction

SAR is related to the rate at which energy is absorbed per unit mass in an object exposed to a radio field. The SAR distribution in a biological body is complicated and is usually carried out by experimental techniques or numerical modeling. The standard recommends limits for two tiers of groups, occupational/controlled and general population/uncontrolled, based on a person's awareness and ability to exercise control over his or her exposure. In general, occupational/controlled exposure limits are higher than the limits for general population/uncontrolled.

6.2. SAR Definition

The SAR definition is the time derivative (rate) of the incremental energy (dW) absorbed by (dissipated in) an incremental mass (dm) contained in a volume element (dv) of a given density (ρ). The equation description is as below:

$$SAR = \frac{d}{dt} \left(\frac{dW}{dm} \right) = \frac{d}{dt} \left(\frac{dW}{\rho dv} \right)$$

SAR is expressed in units of Watts per kilogram (W/kg)

SAR measurement can be either related to the temperature elevation in tissue by

$$SAR = c \left(\frac{\delta T}{\delta t} \right)$$

Where: c is the specific heat capacity, δT is the temperature rise and δt is the exposure duration, or related to the electrical field in the tissue by

$$SAR = \frac{\sigma |E|^2}{\rho}$$

Where: σ is the conductivity of the tissue, ρ is the mass density of tissue and E is the RMS electrical field strength.

However for evaluating SAR of low power transmitter, electrical field measurement is typically applied.

7. Tissue Simulating Liquids

7.1. Targets for tissue simulating liquid

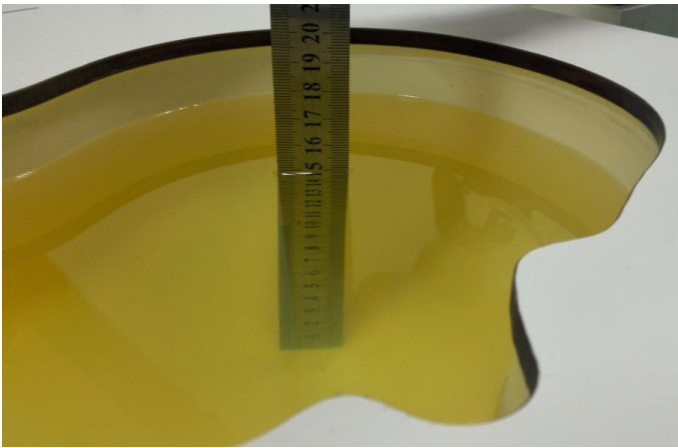

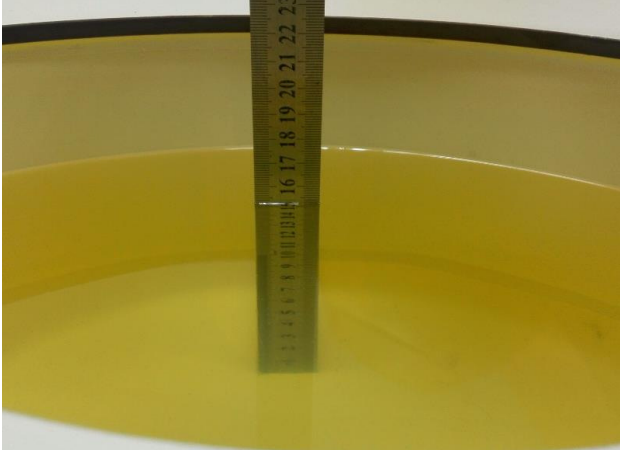

Table 7.1: Targets for tissue simulating liquid

Frequency (MHz)	Liquid Type	Conductivity(σ)	$\pm 5\%$ Range	Permittivity(ϵ)	$\pm 5\%$ Range
835	Head	0.90	0.86~0.95	41.5	39.4~43.6
835	Body	0.97	0.92~1.02	55.2	52.4~58.0
1900	Head	1.40	1.33~1.47	40.0	38.0~42.0
1900	Body	1.52	1.44~1.60	53.3	50.6~56.0
2450	Head	1.80	1.71~1.89	39.2	37.2~41.2
2450	Body	1.95	1.85~2.05	52.7	50.1~55.3

7.2. Dielectric Performance

Table 7.2: Dielectric Performance of Tissue Simulating Liquid

Measurement Value						
Liquid Temperature: 22.5 °C						
Type	Frequency	Permittivity ϵ	Drift (%)	Conductivity σ	Drift (%)	Test Date
Head	835 MHz	40.926	-1.38%	0.936	4.00%	2017-04-12
Head	1900 MHz	39.422	-1.45%	1.372	-2.00%	2017-04-13
Head	2450 MHz	39.588	0.99%	1.789	-0.61%	2017-04-13
Body	835 MHz	55.084	-0.21%	0.998	2.89%	2017-04-12
Body	1900 MHz	53.451	0.28%	1.511	-0.59%	2017-04-13
Body	2450 MHz	53.268	1.08%	1.929	-1.08%	2017-04-13

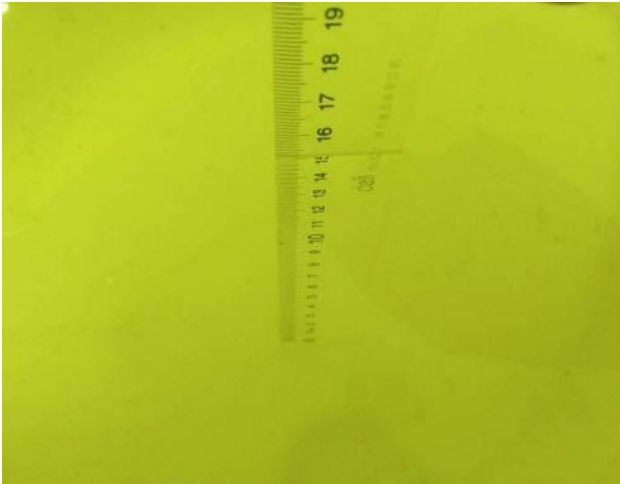
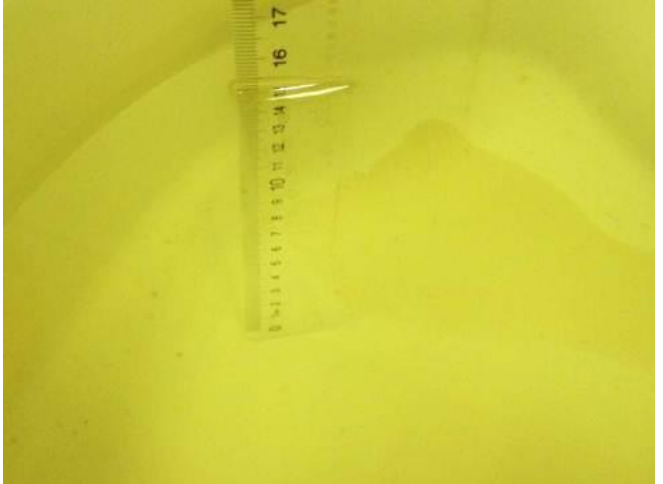
<p>Liquid depth in the Phantom (835 MHz Head)</p>	<p>Liquid depth in the Phantom (1900 MHz Head)</p>
	
<p>Liquid depth in the Phantom (835 MHz Body)</p>	<p>Liquid depth in the Phantom (1900 MHz Body)</p>
	
<p>Liquid depth in the Phantom (2450 MHz Head)</p>	<p>Liquid depth in the Phantom (2450 MHz Body)</p>
	

8. System verification

8.1. System Setup

In the simplified setup for system evaluation, the DUT is replaced by a calibrated dipole and the power source is replaced by a continuous wave that comes from a signal generator. The calibrated dipole must be placed beneath the flat phantom section of the SAM twin phantom with the correct distance holder. The distance holder should touch the phantom surface with a light pressure at the reference marking and be oriented parallel to the long side of the phantom. The equipment setup is shown below:

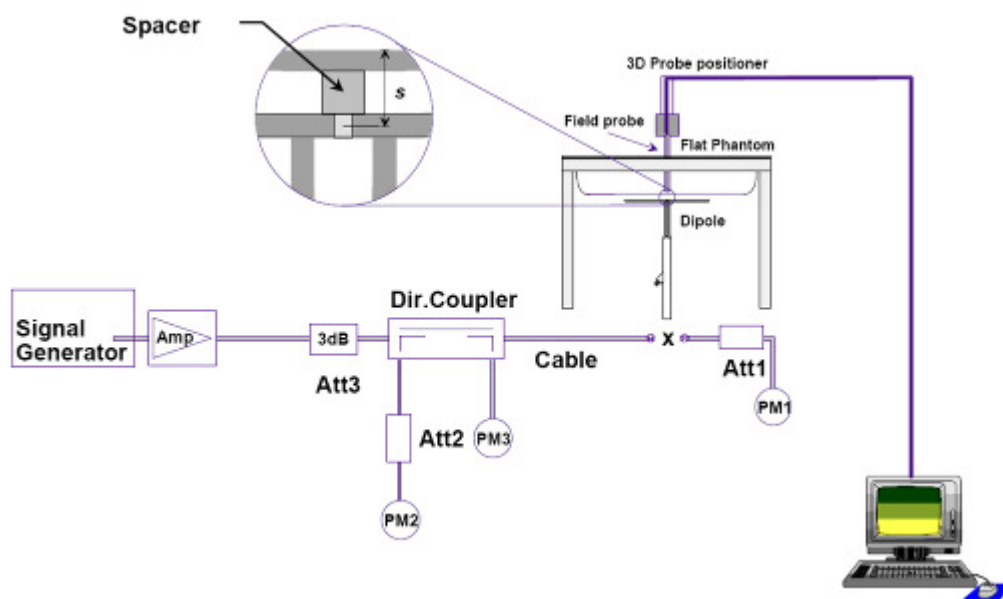

Picture 8.1 System Setup for System Evaluation

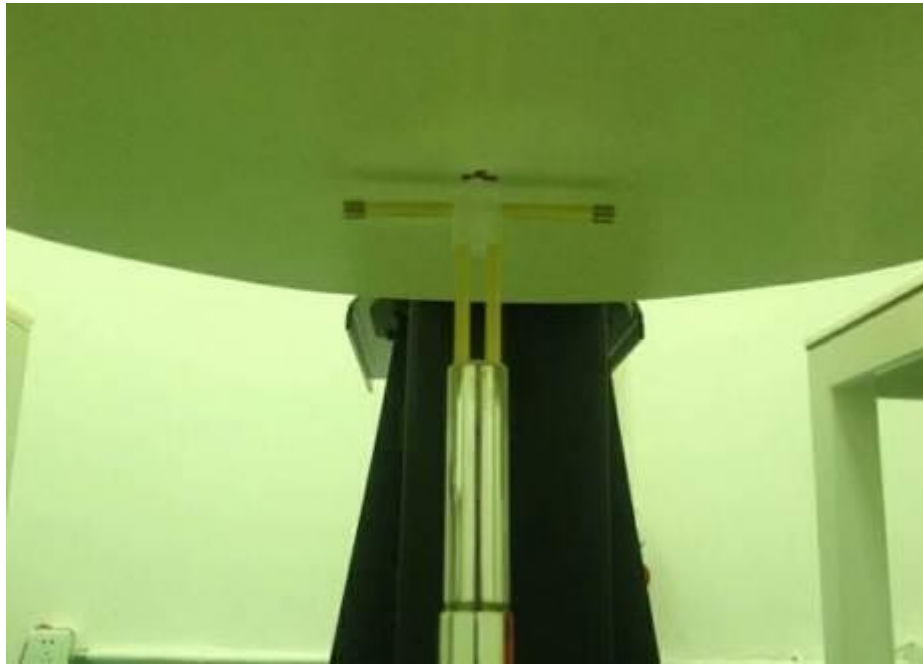

Picture 8.2 Photo of Dipole Setup

8.2. System Verification

SAR system verification is required to confirm measurement accuracy, according to the tissue dielectric media, probe calibration points and other system operating parameters required for measuring the SAR of test device. The system verification must be performed for each frequency band and within the valid range of each probe calibration point required for testing the device.

Table 8.1: System Verification of Head

Verification Results							
Input power level: 1W							
Frequency	Target value (W/kg)		Measured value (W/kg)		Deviation		Test date
	10 g Average	1 g Average	10 g Average	1 g Average	10 g Average	1 g Average	
835 MHz	6.03	9.22	6.08	9.28	0.83%	0.65%	2017-04-12
1900 MHz	21	40.8	20.72	39.64	-1.33%	-2.84%	2017-04-13
2450 MHz	24.3	52.9	24.88	54	2.39%	2.08%	2017-04-13

Table 8.2: System Verification of Body

Verification Results							
Input power level: 1W							
Frequency	Target value (W/kg)		Measured value (W/kg)		Deviation		Test date
	10 g Average	1 g Average	10 g Average	1 g Average	10 g Average	1 g Average	
835 MHz	6.29	9.57	6.28	9.52	-0.16%	-0.52%	2017-04-12
1900 MHz	21.3	41.1	20.92	40.4	-1.78%	-1.70%	2017-04-13
2450 MHz	24.7	53.1	24.6	53.6	-0.40%	0.94%	2017-04-13

9. Measurement Procedures

9.1. Tests to be performed

In order to determine the highest value of the peak spatial-average SAR of a handset, all device positions, configurations and operational modes shall be tested for each frequency band according to steps 1 to 3 below. A flowchart of the test process is shown in Picture 11.1.

Step 1: The tests described in 11.2 shall be performed at the channel that is closest to the centre of the transmit frequency band (f_c) for:

- a) all device positions (cheek and tilt, for both left and right sides of the SAM phantom, as described in Chapter 8),
- b) all configurations for each device position in a), e.g., antenna extended and retracted, and
- c) all operational modes, e.g., analogue and digital, for each device position in a) and configuration in b) in each frequency band.

If more than three frequencies need to be tested according to 11.1 (i.e., $N_c > 3$), then all frequencies, configurations and modes shall be tested for all of the above test conditions.

Step 2: For the condition providing highest peak spatial-average SAR determined in Step 1, perform all tests described in 11.2 at all other test frequencies, i.e., lowest and highest frequencies. In addition, for all other conditions (device position, configuration and operational mode) where the peak spatial-average SAR value determined in Step 1 is within 3 dB of the applicable SAR limit, it is recommended that all other test frequencies shall be tested as well.

Step 3: Examine all data to determine the highest value of the peak spatial-average SAR found in Steps 1 to 2.

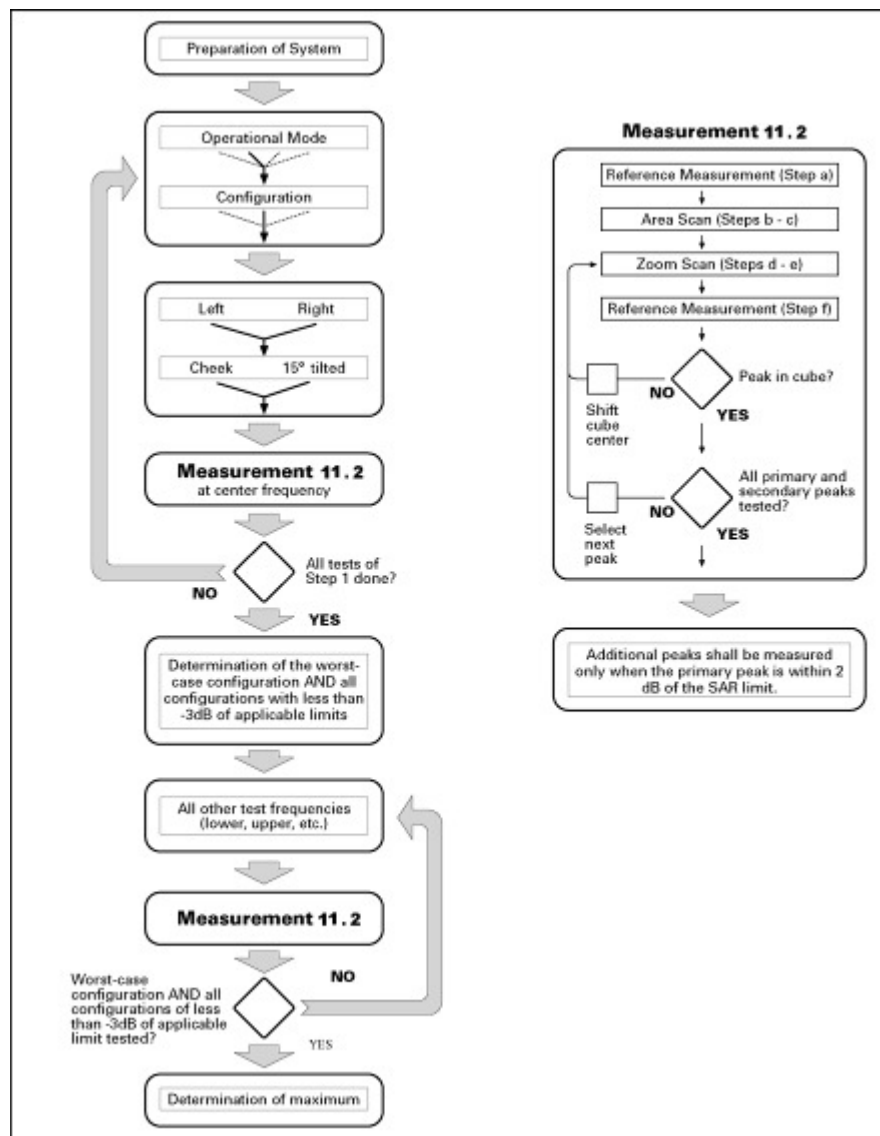

Picture 9.1 Block diagram of the tests to be performed

9.2. General Measurement Procedure

The following procedure shall be performed for each of the test conditions (see Picture 11.1) described in 11.1:

- a) Measure the local SAR at a test point within 8 mm or less in the normal peak direction from the inner surface of the phantom.
- b) Measure the two-dimensional SAR distribution within the phantom (area scan procedure). The boundary of the measurement area shall not be closer than 20 mm from the phantom side walls. The distance between the measurement points should enable the detection of the location of local maximum with an accuracy of better than half the linear dimension of the tissue cube after

interpolation. A maximum grid spacing of 20 mm for frequencies below 3 GHz and $(60/f \text{ [GHz]})$ mm for frequencies of 3GHz and greater is recommended. The maximum distance between the geometrical centre of the probe detectors and the inner surface of the phantom shall be 5 mm for frequencies below 3 GHz and $\delta \ln(2)/2$ mm for frequencies of 3 GHz and greater, where δ is the plane wave skin depth and $\ln(x)$ is the natural logarithm. The maximum variation of the sensor-phantom surface shall be ± 1 mm for frequencies below 3 GHz and ± 0.5 mm for frequencies of 3 GHz and greater. At all measurement points the angle of the probe with respect to the line normal to the surface should be less than 5° . If this cannot be achieved for a measurement distance to the phantom inner surface shorter than the probe diameter, additional uncertainty evaluation is needed.

c) From the scanned SAR distribution, identify the position of the maximum SAR value, in addition identify the positions of any local maxima with SAR values within 2 dB of the maximum value that are not within the zoom-scan volume; additional peaks shall be measured only when the primary peak is within 2 dB of the SAR limit. This is consistent with the 2 dB threshold already stated;

d) Measure the three-dimensional SAR distribution at the local maxima locations identified in step c). The horizontal grid step shall be $(24/f[\text{GHz}])$ mm or less but not more than 8 mm. The minimum zoom size of 30 mm by 30 mm and 30 mm for frequencies below 3 GHz. For higher frequencies, the minimum zoom size of 22 mm by 22 mm and 22 mm. The grid step in the vertical direction shall be $(8-f[\text{GHz}])$ mm or less but not more than 5 mm, if uniform spacing is used. If variable spacing is used in the vertical direction, the maximum spacing between the two closest measured points to the phantom shell shall be $(12 / f[\text{GHz}])$ mm or less but not more than 4 mm, and the spacing between further points shall increase by an incremental factor not exceeding 1.5. When variable spacing is used, extrapolation routines shall be tested with the same spacing as used in measurements. The maximum distance between the geometrical centre of the probe detectors and the inner surface of the phantom shall be 5 mm for frequencies below 3 GHz and $\delta \ln(2)/2$ mm for frequencies of 3 GHz and greater, where δ is the plane wave skin depth and $\ln(x)$ is the natural logarithm. Separate grids shall be centered on each of the local SAR maxima found in step c). Uncertainties due to field distortion between the media boundary and the dielectric enclosure of the probe should also be minimized, which is achieved if the distance between the phantom surface and physical tip of the probe is larger than probe tip diameter. Other methods may utilize correction procedures for these boundary effects that enable high precision measurements closer than half the probe diameter. For all measurement points, the angle of the probe with respect to the flat phantom surface shall be less than 5° . If this cannot be achieved an additional uncertainty evaluation is needed.

e) Use post processing(e.g. interpolation and extrapolation) procedures to determine the local SAR values at the spatial resolution needed for mass averaging.

9.3. Bluetooth & Wi-Fi Measurement Procedures for SAR

Normal network operating configurations are not suitable for measuring the SAR of 802.11 transmitters in general. Unpredictable fluctuations in network traffic and antenna diversity conditions can introduce undesirable variations in SAR results. The SAR for these devices should be measured using chipset based test mode software to ensure that the results are consistent and reliable.

Chipset based test mode software is hardware dependent and generally varies among manufacturers. The device operating parameters established in a test mode for SAR measurements must be identical to those programmed in production units, including output power levels, amplifier gain settings and other RF performance tuning parameters. The test frequencies should correspond to actual channel frequencies defined for domestic use. SAR for devices with switched diversity should be measured with only one antenna transmitting at a time during each SAR measurement, according to a fixed modulation and data rate. The same data pattern should be used for all measurements.

9.4. Power Drift

To control the output power stability during the SAR test, DASY4 system calculates the power drift by measuring the E-field at the same location at the beginning and at the end of the measurement for each test position. These drift values can be found in Section 14 labeled as: (Power Drift [dB]). This ensures that the power drift during one measurement is within 5%.

10. Area Scan Based 1-g SAR

10.1 Requirement of KDB

According to the KDB447498 D01 v06, when the implementation is based the specific polynomial fit algorithm as presented at the 29th Bioelectromagnetics Society meeting (2007) and the estimated 1-g SAR is ≤ 1.2 W/kg, a zoom scan measurement is not required provided it is also not needed for any other purpose; for example, if the peak SAR location required for simultaneous transmission SAR test exclusion can be determined accurately by the SAR system or manually to discriminate between distinctive peaks and scattered noisy SAR distributions from area scans.

There must not be any warning or alert messages due to various measurement concerns identified by the SAR system; for example, noise in measurements, peaks too close to scan boundary, peaks are too sharp, spatial resolution and uncertainty issues etc. The SAR system verification must also demonstrate that the area scan estimated 1-g SAR is within 3% of the zoom scan 1-g SAR (See Annex B). When all the SAR results for each exposure condition in a frequency band and wireless mode are based on estimated 1-g SAR, the 1-g SAR for the highest SAR configuration must be determined by a zoom scan.

10.2 Fast SAR Algorithms

The approach is based on the area scan measurement applying a frequency dependent attenuation parameter. This attenuation parameter was empirically determined by analyzing a large number of phones. The MOTOROLA FAST SAR was developed and validated by the MOTOROLA Research Group in Ft. Lauderdale.

In the initial study, an approximation algorithm based on Linear fit was developed. The accuracy of the algorithm has been demonstrated across a broad frequency range (136-2450 MHz) and for both 1- and 10-g averaged SAR using a sample of 264 SAR measurements from 55 wireless handsets. For the sample size studied, the root-mean-squared errors of the algorithm are 1.2% and 5.8% for 1- and 10-g averaged SAR, respectively. The paper describing the algorithm in detail is expected to be published in August 2004 within the Special Issue of Transactions on MTT.

In the second step, the same research group optimized the fitting algorithm to an Polynomial fit whereby the frequency validity was extended to cover the range 30-6000MHz. Details of this study can be found in the BEMS 2007 Proceedings.

Both algorithms are implemented in DASY software.

11. Conducted Output Power

11.1. Manufacturing tolerance

Table 11.1: GSM Speech

GSM 850			
Channel	Channel 128	Channel 190	Channel 251
Maximum Target Value (dBm)	33.0	33.0	33.0
GSM1900			
Channel	Channel 512	Channel 661	Channel 810
Maximum Target Value (dBm)	30.5	30.5	30.5

Table 11.2: GPRS/EGPRS (GMSK Modulation)

GSM 850				
Channel		128	190	251
1 Txslots	Maximum Target Value (dBm)	33.0	33.0	33.0
2 Txslots	Maximum Target Value (dBm)	32.0	32.0	32.0
3 Txslots	Maximum Target Value (dBm)	30.0	30.0	30.0
4 Txslots	Maximum Target Value (dBm)	29.0	29.0	29.0
GSM 1900				
Channel		512	661	810
1 Txslots	Maximum Target Value (dBm)	30.5	30.5	30.5
2 Txslots	Maximum Target Value (dBm)	29.5	29.5	29.5
3 Txslots	Maximum Target Value (dBm)	27.5	27.5	27.5
4 Txslots	Maximum Target Value (dBm)	26.5	26.5	26.5

Table 11.3: WiFi

WiFi 802.11b					
Channel	Channel 1	Channel 6	Channel 11	Channel 12	Channel 13
Maximum Target Value (dBm)	13	13	13	13	13
WiFi 802.11g					
Channel	Channel 1	Channel 6	Channel 11	Channel 12	Channel 13
Maximum Target Value (dBm)	12	12	12	12	12
WiFi 802.11n 20M					
Channel	Channel 1	Channel 6	Channel 11	Channel 12	Channel 13
Maximum Target Value (dBm)	11	11	11	11	11
WiFi 802.11n 40M					
Channel	Channel 3	Channel 6	Channel 9	Channel 10	Channel 11
Maximum Target Value (dBm)	10	10	10	10	10

Table 11.4: Bluetooth

Bluetooth 2.1			
Channel	Channel 0	Channel 39	Channel 78
GFSK Maximum Target Value (dBm)	2.0	2.0	2.0
$\pi/4$ DQPSK Maximum Target Value (dBm)	1	1	1
8DPSK Maximum Target Value (dBm)	1	1	1
Bluetooth 4.0			
Channel	Channel 0	Channel 39	Channel 78
Maximum Target Value (dBm)	-6.0	-6.0	-6.0

11.2. GSM Measurement result

During the process of testing, the EUT was controlled via Agilent Digital Radio Communication tester (E5515C) to ensure the maximum power transmission and proper modulation. This result contains conducted output power for the EUT. In all cases, the measured peak output power should be greater and within 5% than EMI measurement.

Table 11.13: The conducted power measurement results for GSM

GSM 850MHZ	Conducted Power (dBm)		
	Channel 128(824.2MHz)	Channel 190(836.6MHz)	Channel 251(848.6MHz)
	32.59	32.64	32.70
GSM 1900MHZ	Conducted Power (dBm)		
	Channel 512(1850.2MHz)	Channel 661(1880MHz)	Channel 810(1909.8MHz)
	30.21	30.25	30.41

Table 11.14: The conducted power measurement results for GPRS/EGPRS (GMSK)

GSM 850 GPRS/EGPRS	Measured Power (dBm)			calculation	Averaged Power (dBm)		
	128	190	251		128	190	251
1 Txslot	32.57	32.64	32.69	-9.03dB	23.54	23.61	23.66
2 Txslots	31.52	31.61	31.65	-6.02dB	25.50	25.59	25.63
3 Txslots	29.67	29.87	29.84	-4.26dB	25.41	25.61	25.58
4 Txslots	28.59	28.62	28.65	-3.01dB	25.58	25.61	25.64
GSM 1900 GPRS/EGPRS	Measured Power (dBm)			calculation	Averaged Power (dBm)		
	512	661	810		512	661	810
1 Txslot	30.20	30.23	30.41	-9.03dB	21.17	21.20	21.38
2 Txslots	29.11	29.20	29.32	-6.02dB	23.09	23.18	23.30
3 Txslots	27.23	27.37	27.47	-4.26dB	22.97	23.11	23.21
4 Txslots	26.14	26.21	26.33	-3.01dB	23.13	23.20	23.32

NOTES:

1) Division Factors

To average the power, the division factor is as follows:

1TX-slot = 1 transmit time slot out of 8 time slots=> conducted power divided by (8/1) => -9.03dB

2TX-slots = 2 transmit time slots out of 8 time slots=> conducted power divided by (8/2) => -6.02dB

3TX-slots = 3 transmit time slots out of 8 time slots=> conducted power divided by (8/3) => -4.26dB

4TX-slots = 4 transmit time slots out of 8 time slots=> conducted power divided by (8/4) => -3.01dB

According to the conducted power as above, the body measurements are performed with 4Txslots for 850MHz ; 4Txslots for1900MHz;

11.3. Wi-Fi and BT Measurement result

Table 11.15: The conducted power for Bluetooth

GFSK			
Channel	Ch0 (2402 MHz)	Ch39 (2441MHz)	CH78 (2480MHz)
Conducted Output Power (dBm)	0.587	0.843	1.218
$\pi/4$ DQPSK			
Channel	Ch0 (2402 MHz)	Ch39 (2441MHz)	CH78 (2480MHz)
Conducted Output Power (dBm)	-0.544	-0.382	-0.290
8DPSK			
Channel	Ch0 (2402 MHz)	Ch39 (2441MHz)	CH78 (2480MHz)
Conducted Output Power (dBm)	-0.52	-0.375	-0.172

Table 11.16: The conducted power for Bluetooth(BT4.0)

GFSK			
Channel	Ch0 (2402 MHz)	Ch19 (2440MHz)	CH39 (2480MHz)
Conducted Output Power (dBm)	-7.28	-6.906	-6.326

NOTE: According to KDB447498 D01 BT standalone SAR are not required, because maximum average output power is less than 10mW.

When the standalone SAR test exclusion is applied to an antenna that transmits simultaneously with other antennas, the standalone SAR must be estimated according to the following to determine simultaneous transmission SAR test exclusion:

(max. power of channel, including tune-up tolerance, mW)/(min. test separation distance, mm) • [$\sqrt{f(\text{GHz})/x}$] W/kg for test separation distances ≤ 50 mm;
 where $x = 7.5$ for 1-g SAR, and $x = 18.75$ for 10-g SAR.

SAR head value of BT is 0.066 W/Kg. SAR body value of BT is 0.033 W/Kg.

The default power measurement procedures are:

a) Power must be measured at each transmit antenna port according to the DSSS and OFDM transmission configurations in each standalone and aggregated frequency band.

b) Power measurement is required for the transmission mode configuration with the highest maximum output power specified for production units.

1) When the same highest maximum output power specification applies to multiple transmission modes, the largest channel bandwidth configuration with the lowest order modulation and lowest data rate is measured.

2) When the same highest maximum output power is specified for multiple largest channel bandwidth configurations with the same lowest order modulation or lowest order modulation and lowest data rate, power measurement is required for all equivalent 802.11 configurations with the same maximum output power.

c) For each transmission mode configuration, power must be measured for the highest and lowest channels; and at the mid-band channel(s) when there are at least 3 channels. For configurations with multiple mid-band channels, due to an even number of channels, both channels should be measured.

During WLAN SAR testing EUT is configured with the WLAN continuous TX tool, and the transmission duty factor was monitored on the spectrum analyzer with zero-span setting, the duty cycle is 100%.

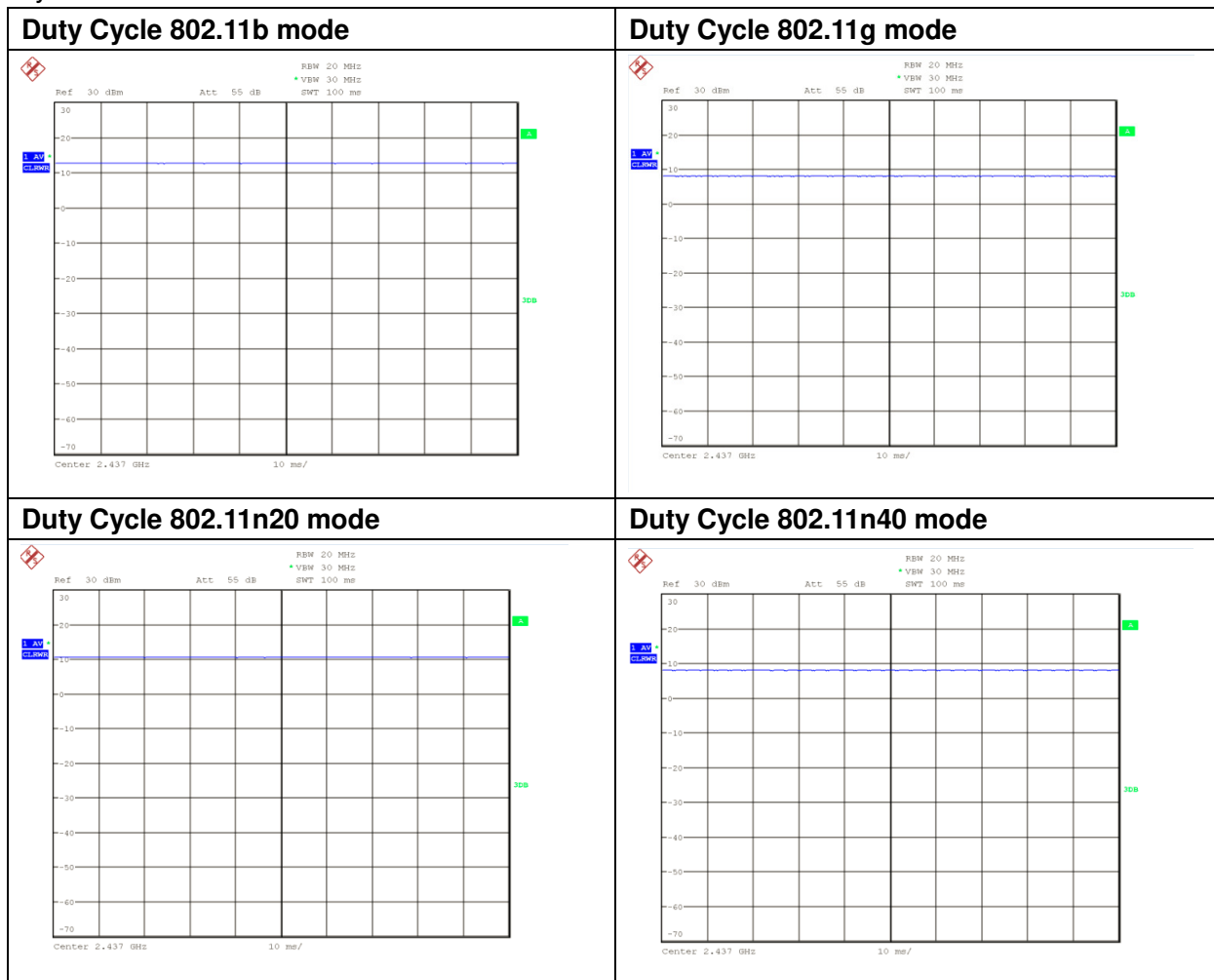

Table 11.17: The average conducted power for WiFi

Mode	Channel	Frequency	Average power(dBm)
802.11 b	1	2412 MHZ	12.92
	6	2437 MHZ	12.83
	11	2462 MHZ	12.80
	12	2467 MHZ	12.73
	13	2472 MHZ	12.62
802.11 g	1	2412 MHZ	11.95
	6	2437 MHZ	11.83
	11	2462 MHZ	11.72
	12	2467 MHZ	11.56
	13	2472 MHZ	11.42
802.11 n 20M	1	2412 MHZ	10.51
	6	2437 MHZ	9.99
	11	2462 MHZ	10.36
	12	2467 MHZ	10.24
	13	2472 MHZ	10.21
802.11 n 40M	3	2422 MHZ	9.91
	6	2437 MHZ	9.89
	9	2452 MHZ	9.71
	10	2457 MHZ	9.66
	11	2462 MHZ	9.43

2.4 GHz 802.11g/n OFDM SAR Test Exclusion Requirements

When SAR measurement is required for 2.4 GHz 802.11g/n OFDM configurations, the measurement and test reduction procedures for OFDM are applied. SAR is not required for the following 2.4 GHz OFDM conditions.

- a) When KDB Publication 447498 D01 SAR test exclusion applies to the OFDM configuration.
- b) When the highest *reported* SAR for DSSS is adjusted by the ratio of OFDM to DSSS specified maximum output power and the adjusted SAR is ≤ 1.2 W/kg.

12. Simultaneous TX SAR Considerations

12.1. Introduction

The following procedures adopted from “FCC SAR Considerations for Cell Phones with Multiple Transmitters” are applicable to handsets with built-in unlicensed transmitters such as 802.11 a/b/g and Bluetooth devices which may simultaneously transmit with the licensed transmitter.

For this device, the BT and Wi-Fi can transmit simultaneous with other transmitters.

12.2. Transmit Antenna Separation Distances

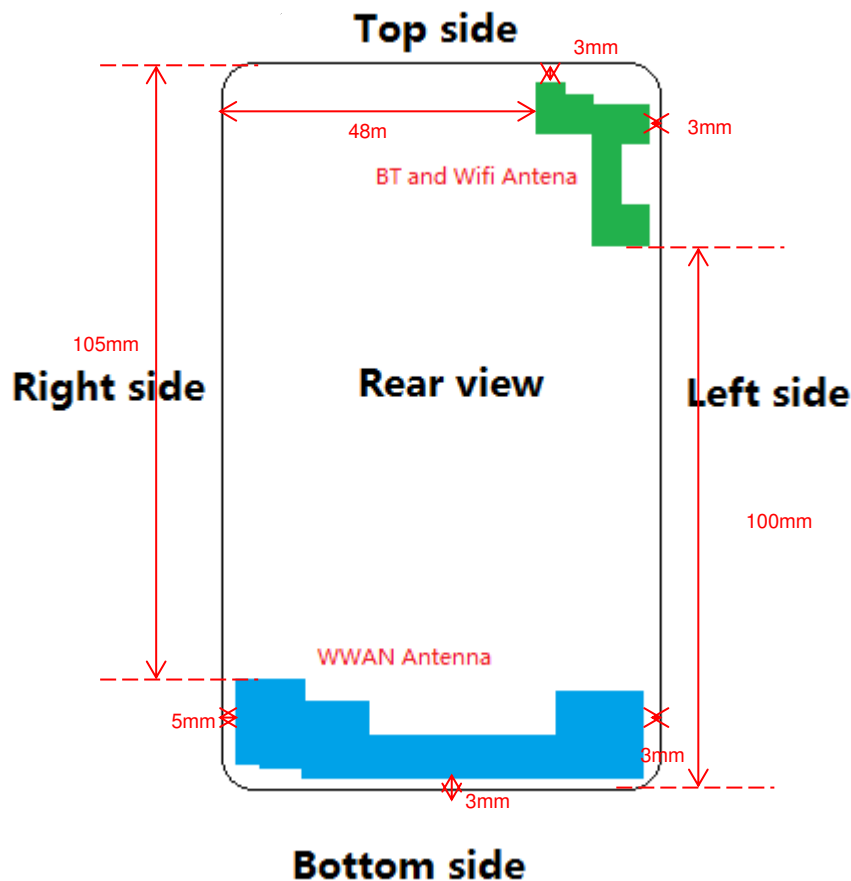

Picture 12.1 Antenna Locations

Note:

WWAN Antenna meaning is 2G TX Antenna

12.3. Standalone SAR Test Exclusion Considerations

Standalone 1-g head or body SAR evaluation by measurement or numerical simulation is not required when the corresponding SAR Exclusion Threshold condition, listed below, is satisfied. The 1-g SAR test exclusion threshold for 100 MHz to 6 GHz at test separation distances ≤ 50 mm are determined by:

$$\left[\frac{\text{(max. power of channel, including tune-up tolerance, mW)}}{\text{(min. test separation distance, mm)}} \cdot \sqrt{f(\text{GHz})} \right] \leq 3.0 \text{ for 1-g SAR, where}$$

- f(GHz) is the RF channel transmit frequency in GHz
- Power and distance are rounded to the nearest mW and mm before calculation
- The result is rounded to one decimal place for comparison

According to the KDB447498 appendix A, the SAR test exclusion threshold for 2450MHz at 5mm test separation distances is 10mW.

$$\frac{\text{(max. power of channel, including tune-up tolerance, mW)}}{\text{(min. test separation distance, mm)}} \cdot \sqrt{\text{Frequency (GHz)}} \leq 3.0$$

Based on the above equation, Bluetooth SAR was not required:

Evaluation=0.497 < 3.0

Based on the above equation, WiFi SAR was required:

Evaluation=4.975 > 3.0

12.4. SAR Measurement Positions

According to the KDB941225 D06 Hot Spot SAR v01, the edges with less than 2.5 cm distance to the antennas need to be tested for SAR.

SAR Measurement Positions						
Antenna Mode	Phantom	Ground	Left	Right	Top	Bottom
WWAN	Yes	Yes	Yes	Yes	No	Yes
WLAN	Yes	Yes	Yes	No	Yes	No

13. Evaluation of Simultaneous

Table 13.1: Summary of Transmitters

Band/Mode	Frequency (GHz)	SAR test exclusion threshold(mW)	RF output power (mW)
Bluetooth	2.41	10	1.585
2.4GHz WLAN 802.11 b/g/n	2.45	10	15.849

Table13.2 Simultaneous transmission SAR

Standalone SAR for 2G(W/Kg)					
Test Position			GSM	GSM	Highest
			850	1900	SAR
Head voice	Left	Cheek	0.248	0.967	0.967
		Tilt 15°	0.164	0.109	0.164
	Right	Cheek	0.352	0.401	0.401
		Tilt 15°	0.194	0.185	0.194
Hotspot 10mm	Phantom Side		0.678	0.597	0.678
	Ground Side		0.862	0.924	0.924
	Left Side		0.123	0.664	0.664
	Right Side		0.519	0.098	0.519
	Bottom Side		0.054	0.355	0.355
	Top Side		--	--	--

Transmission SAR(W/Kg)						
Test Position		2G	WIFI	BT	SUM	
Head	Left	Cheek	0.967	0.180	0.066	1.147
		Tilt 15°	0.164	0.060	0.066	0.230
	Right	Cheek	0.401	0.671	0.066	1.072
		Tilt 15°	0.194	0.375	0.066	0.569
Hotspot 10mm	Phantom Side		0.678	0.317	0.033	0.995
	Ground Side		0.924	0.264	0.033	1.188
	Left Side		0.664	0.036	0.033	0.700
	Right Side		0.519	0.041	0.033	0.560
	Bottom Side		0.355	--	0.033	0.355
	Top Side		--	0.227	0.033	0.227

According to the conducted power measurement result, we can draw the conclusion that: stand-alone SAR for WiFi should be performed. Then, simultaneous transmission SAR for WiFi/BT is considered with measurement results of GSM and WiFi/BT. According to the above table, the sum of reported SAR values for GSM and WiFi < 1.6W/kg. So the simultaneous transmission SAR is not required for WiFi/BT transmitter.

14. SAR Test Result

14.1. SAR results for Fast SAR

Table 14.1: Duty Cycle

Duty Cycle	
Speech for GSM900/1800	1:8.3
GPRS for GSM900/1800	1:2
WiFi	1:1

According to KDB 646217D04 When the reported SAR for a body-worn accessory, measured without a headset connected to the handset, is > 1.2 W/kg, the highest reported SAR configuration for that wireless mode and frequency band should be repeated for the body-worn accessory with a headset attached to the handset. So GSM speech with headset for Body test is not required.

Table 14.2: SAR Values(GSM 850 MHz Band-Head)

Frequency		Side	Test Position	Figure No.	Measured average power(dBm)	Maximum allowed Power (dBm)	Scaling factor	Measured SAR(1g) (W/kg)	Reported SAR(1g) (W/kg)	Power Drift (dB)
MHz	Ch.									
836.6	190	Left	Touch	/	32.64	33.0	1.086	0.228	0.248	0.10
836.6	190	Left	Tilt	/	32.64	33.0	1.086	0.151	0.164	-0.06
836.6	190	Right	Touch	/	32.64	33.0	1.086	0.249	0.270	-0.09
836.6	190	Right	Tilt	/	32.64	33.0	1.086	0.179	0.194	0.06
824.2	128	Right	Touch	/	32.59	33.0	1.099	0.223	0.245	0.12
848.8	251	Right	Touch	Fig.1	32.70	33.0	1.072	0.328	0.352	0.14

Table 14.3: SAR Values (GSM 850 MHz Band-Body)

Frequency		Mode (number of timeslots)	Test Position	Figure No.	Measured average power(dBm)	Maximum allowed Power (dBm)	Scaling factor	Measured SAR(1g) (W/kg)	Reported SAR(1g) (W/kg)	Power Drift (dB)
MHz	Ch.									
836.6	190	GPRS 4TS	Phantom	/	28.62	29.0	1.091	0.621	0.678	0.03
836.6	190	GPRS 4TS	Ground	/	28.62	29.0	1.091	0.665	0.726	0.06
836.6	190	GPRS 4TS	Left	/	28.62	29.0	1.091	0.113	0.123	0.12
836.6	190	GPRS 4TS	Right	/	28.62	29.0	1.091	0.476	0.519	0.12
836.6	190	GPRS 4TS	Bottom	/	28.62	29.0	1.091	0.0493	0.054	-0.15
824.2	128	GPRS 4TS	Ground	/	28.59	29.0	1.099	0.581	0.639	0.03
848.8	251	GPRS 4TS	Ground	Fig.2	28.65	29.0	1.084	0.79	0.856	0.05
Repeated										
848.8	251	GPRS 4TS	Ground	Fig.3	28.65	29.0	1.084	0.795	0.862	-0.12

Note: The distance between the EUT and the phantom bottom is 10mm.

Table 14.4: SAR Values(GSM 1900 MHz Band-Head)

Frequency		Side	Test Position	Figure No.	Measured average power(dBm)	Maximum allowed Power (dBm)	Scaling factor	Measured SAR(1g) (W/kg)	Reported SAR(1g) (W/kg)	Power Drift (dB)
MHz	Ch.									
1880	661	Left	Touch	/	30.25	30.5	1.059	0.819	0.867	-0.15
1880	661	Left	Tilt	/	30.25	30.5	1.059	0.103	0.109	0.06
1880	661	Right	Touch	/	30.25	30.5	1.059	0.379	0.401	0.01
1880	661	Right	Tilt	/	30.25	30.5	1.059	0.175	0.185	0.07
1850.2	512	Left	Touch	Fig.4	30.21	30.5	1.069	0.905	0.967	0.11
1909.8	810	Left	Touch	/	30.41	30.5	1.021	0.662	0.676	0.14
Repeated										
1850.2	512	Left	Touch	Fig.5	30.21	30.5	1.069	0.887	0.948	0.06

Table 14.5: SAR Values (GSM 1900 MHz Band-Body)

Frequency		Mode (number of timeslots)	Test Position	Figure No.	Measured average power(dBm)	Maximum allowed Power (dBm)	Scaling factor	Measured SAR(1g) (W/kg)	Reported SAR(1g) (W/kg)	Power Drift (dB)
MHz	Ch.									
1880	661	GPRS 4TS	Phantom	/	26.21	26.5	1.069	0.558	0.597	0.04
1880	661	GPRS 4TS	Ground	/	26.21	26.5	1.069	0.788	0.842	-0.12
1880	661	GPRS 4TS	Left	/	26.21	26.5	1.069	0.621	0.664	0.07
1880	661	GPRS 4TS	Right	/	26.21	26.5	1.069	0.0915	0.098	-0.12
1880	661	GPRS 4TS	Bottom	/	26.21	26.5	1.069	0.332	0.355	0.14
1850.2	512	GPRS 4TS	Ground	/	26.14	26.5	1.086	0.733	0.796	0.13
1909.8	810	GPRS 4TS	Ground	Fig.6	26.33	26.5	1.040	0.878	0.913	0.15
Repeated										
1909.8	810	GPRS 4TS	Ground	Fig.7	26.33	26.5	1.040	0.888	0.924	0.15

Note: The distance between the EUT and the phantom bottom is 10mm.

Table 14.6: SAR Values (Wi-Fi 802.11b - Head)

Frequency		Side	Test Position	Figure No.	Measured average power(dBm)	Maximum allowed Power (dBm)	Scaling factor	Measured SAR(1g) (W/kg)	Reported SAR(1g) (W/kg)	Power Drift (dB)
MHz	Ch.									
2412	1	Left	Touch	/	12.92	13	1.019	0.177	0.180	0.09
2412	1	Left	Tilt	/	12.92	13	1.019	0.0591	0.060	0.12
2412	1	Right	Touch	Fig.8	12.92	13	1.019	0.659	0.671	0.07
2412	1	Right	Tilt	/	12.92	13	1.019	0.368	0.375	0.03
2437	6	Right	Touch	/	12.83	13	1.040	0.506	0.526	-0.05
2462	11	Right	Touch	/	12.80	13	1.047	0.392	0.410	0.13

Table 14.7 SAR Values (Wi-Fi 802.11b - Body)

Frequency		Mode (number of timeslots)	Test Position	Figure No.	Measured average power(dBm)	Maximum allowed Power (dBm)	Scaling factor	Measured SAR(1g) (W/kg)	Reported SAR(1g) (W/kg)	Power Drift (dB)
MHz	Ch.									
2412	1	Wi-Fi 2450	Phantom	/	12.92	13	1.019	0.286	0.291	0.03
2412	1	Wi-Fi 2450	Ground	/	12.92	13	1.019	0.259	0.264	0.11
2412	1	Wi-Fi 2450	Left	/	12.92	13	1.019	0.0350	0.036	-0.17
2412	1	Wi-Fi 2450	Right	/	12.92	13	1.019	0.0398	0.041	0.09
2412	1	Wi-Fi 2450	Top	/	12.92	13	1.019	0.223	0.227	0.07
2437	6	Wi-Fi 2450	Phantom	Fig.9	12.83	13	1.040	0.305	0.317	0.03
2462	11	Wi-Fi 2450	Phantom	/	12.80	13	1.047	0.167	0.175	0.18

Note: The distance between the EUT and the phantom bottom is 10mm.

SAR results for Standard procedure

There is zoom scan measurement to be added for the highest measured SAR in each exposure configuration/band.

Table 14.8: SAR Values(GSM 850 MHz Band-Head)

Frequency		Side	Test Position	Figure No.	Measured average power(dBm)	Maximum allowed Power (dBm)	Scaling factor	Measured SAR(1g) (W/kg)	Reported SAR(1g) (W/kg)	Power Drift (dB)
MHz	Ch.									
848.8	251	Right	Touch	Fig.1	32.70	33.0	1.072	0.328	0.352	0.14

Table 14.9: SAR Values (GSM 850 MHz Band-Body)

Frequency		Mode (number of timeslots)	Test Position	Figure No.	Measured average power(dBm)	Maximum allowed Power (dBm)	Scaling factor	Measured SAR(1g) (W/kg)	Reported SAR(1g) (W/kg)	Power Drift (dB)
MHz	Ch.									
848.8	251	GPRS 4TS	Ground	Fig.2	28.65	29.0	1.084	0.79	0.856	0.05
Repeated										
848.8	251	GPRS 4TS	Ground	Fig.3	28.65	29.0	1.084	0.795	0.862	-0.12

Note: The distance between the EUT and the phantom bottom is 10mm.

Table 14.10: SAR Values(GSM 1900 MHz Band-Head)

Frequency		Side	Test Position	Figure No.	Measured average power(dBm)	Maximum allowed Power (dBm)	Scaling factor	Measured SAR(1g) (W/kg)	Reported SAR(1g) (W/kg)	Power Drift (dB)
MHz	Ch.									
1850.2	512	Left	Touch	Fig.4	30.21	30.5	1.069	0.905	0.967	0.11
Repeated										
1850.2	512	Left	Touch	Fig.5	30.21	30.5	1.069	0.887	0.948	0.06

Table 14.11: SAR Values (GSM 1900 MHz Band-Body)

Frequency		Mode (number of timeslots)	Test Position	Figure No.	Measured average power(dBm)	Maximum allowed Power (dBm)	Scaling factor	Measured SAR(1g) (W/kg)	Reported SAR(1g) (W/kg)	Power Drift (dB)
MHz	Ch.									
1909.8	810	GPRS 4TS	Ground	Fig.6	26.33	26.5	1.040	0.878	0.913	0.15
Repeated										
1909.8	810	GPRS 4TS	Ground	Fig.7	26.33	26.5	1.040	0.888	0.924	0.15

Note: The distance between the EUT and the phantom bottom is 10mm.

Table 14.12: SAR Values (Wi-Fi 802.11b - Head)

Frequency		Side	Test Position	Figure No.	Measured average power(dBm)	Maximum allowed Power (dBm)	Scaling factor	Measured SAR(1g) (W/kg)	Reported SAR(1g) (W/kg)	Power Drift (dB)
MHz	Ch.									
2412	1	Right	Touch	Fig.8	12.92	13	1.019	0.659	0.671	0.07

Table 14.13 SAR Values (Wi-Fi 802.11b - Body)

Frequency		Mode (number of timeslots)	Test Position	Figure No.	Measured average power(dBm)	Maximum allowed Power (dBm)	Scaling factor	Measured SAR(1g) (W/kg)	Reported SAR(1g) (W/kg)	Power Drift (dB)
MHz	Ch.									
2437	6	Wi-Fi 2450	Phantom	Fig.9	12.83	13	1.040	0.305	0.317	0.03

Note: The distance between the EUT and the phantom bottom is 10mm.

15. SAR Measurement Variability

SAR measurement variability must be assessed for each frequency band, which is determined by the SAR probe calibration point and tissue-equivalent medium used for the device measurements. When both head and body tissue-equivalent media are required for SAR measurements in a frequency band, the variability measurement procedures should be applied to the tissue medium with the highest measured SAR, using the highest measured SAR configuration for that tissue-equivalent medium.

The following procedures are applied to determine if repeated measurements are required.

- 1) Repeated measurement is not required when the original highest measured SAR is < 0.80 W/kg; steps 2) through 4) do not apply.
- 2) When the original highest measured SAR is ≥ 0.80 W/kg, repeat that measurement once.
- 3) Perform a second repeated measurement only if the ratio of largest to smallest SAR for the original and first repeated measurements is > 1.20 or when the original or repeated measurement is ≥ 1.45 W/kg (~ 10% from the 1-g SAR limit).
- 4) Perform a third repeated measurement only if the original, first or second repeated measurement is ≥ 1.5 W/kg and the ratio of largest to smallest SAR for the original, first and second repeated measurements is > 1.20 .

Table 15.1: SAR Measurement Variability for Body Value (1g)

Frequency		Test Position	Original SAR (W/kg)	First Repeated SAR (W/kg)	The Ratio
MHz	Ch.				
848.8	251	Ground	0.79	0.795	1.006
1850.2	512	Left Touch	0.905	0.887	1.020
1909.8	810	Ground	0.878	0.888	1.011

Note: According to the KDB 865664 D01 repeated measurement is not required when the original highest measured SAR is < 0.8 W/kg.

16. Measurement Uncertainty

Error Description	Unc. value, ±%	Prob. Dist.	Div.	c _i 1g	c _i 10g	Std.Unc ±%,1g	Std.Unc ±%,10g	V _i V _{eff}
Measurement System								
Probe Calibration	6.0	N	1	1	1	6.0	6.0	∞
Axial Isotropy	0.5	R	$\sqrt{3}$	0.7	0.7	0.2	0.2	∞
Hemispherical Isotropy	2.6	R	$\sqrt{3}$	0.7	0.7	1.1	1.1	∞
Boundary Effects	0.8	R	$\sqrt{3}$	1	1	0.5	0.5	∞
Linearity	0.6	R	$\sqrt{3}$	1	1	0.3	0.3	∞
System Detection Limits	1.0	R	$\sqrt{3}$	1	1	0.6	0.6	∞
Readout Electronics	0.7	N	1	1	1	0.7	0.7	∞
Response Time	0	R	$\sqrt{3}$	1	1	0	0	∞
Integration Time	2.6	R	$\sqrt{3}$	1	1	1.5	1.5	∞
RF Ambient Noise	3.0	R	$\sqrt{3}$	1	1	1.7	1.7	∞
RF Ambient Reflections	3.0	R	$\sqrt{3}$	1	1	1.7	1.7	∞
Probe Positioner	1.5	R	$\sqrt{3}$	1	1	0.9	0.9	∞
Probe Positioning	2.9	R	$\sqrt{3}$	1	1	1.7	1.7	∞
Max. SAR Eval.	1.0	R	$\sqrt{3}$	1	1	0.6	0.6	∞
Test Sample Related								
Device Positioning	2.9	N	1	1	1	2.9	2.9	145
Device Holder	3.6	N	1	1	1	3.6	3.6	5
Dipole								
Power Drift	5.0	R	$\sqrt{3}$	1	1	2.9	2.9	∞
Dipole Positioning	2.0	N	1	1	1	2.0	2.0	∞
Dipole Input Power	5.0	N	1	1	1	5.0	5.0	∞
Phantom and Setup								
Phantom Uncertainty	4.0	R	$\sqrt{3}$	1	1	2.3	2.3	∞
Liquid Conductivity (target)	5.0	R	$\sqrt{3}$	0.64	0.43	1.8	1.2	∞
Liquid Conductivity (meas.)	2.5	N	1	0.64	0.43	1.6	1.1	∞
Liquid Permittivity (target)	5.0	R	$\sqrt{3}$	0.6	0.49	1.7	1.4	∞
Liquid Permittivity (meas.)	2.5	N	1	0.6	0.49	1.5	1.2	∞
Combined Std Uncertainty								
						±11.2%	±10.9%	387
Expanded Std Uncertainty								
						±22.4%	±21.8%	

17. Main Test Instrument

Table 17.1: List of Main Instruments

No.	Name	Type	Serial Number	Calibration Date	Valid Period
01	Network analyzer	N5242A	MY51221755	Jan 6, 2017	1 year
02	Power meter	NRVD	102257	May 12, 2016	1 year
03	Power sensor	NRV-Z5	100241		
			100644		
04	Signal Generator	E4438C	MY49072044	Jan 6, 2017	1 Year
05	Amplifier	NTWPA-0086010F	12023024	No Calibration Requested	
06	Coupler	778D	MY4825551	May 12, 2016	1 year
07	BTS	E5515C	MY50266468	Jan 18, 2016	1 year
08	E-field Probe	EX3DV4	7375	Dec 8, 2016	1 year
			3754	Jan 13, 2017	
09	DAE	SPEAG DAE3	360	Nov 8, 2016	1 year
		SPEAG DAE4	1244	Dec 12,2016	
10	Dipole Validation Kit	SPEAG D835V2	4d112	Oct 22, 2015	2 year
		SPEAG D1900V2	5d134	Nov 4,2015	2 year
		SPEAG D2450V2	858	Oct 30,2015	2 year

ANNEX A. GRAPH RESULTS

GSM 850MHz Right Cheek High

Date/Time: 2017/4/13

Electronics: DAE4 Sn1244

Medium: Head 835MHz

Medium parameters used: $f = 849 \text{ MHz}$; $\sigma = 0.941 \text{ S/m}$; $\epsilon_r = 40.788$; $\rho = 1000 \text{ kg/m}^3$

Ambient Temperature: 22.5°C Liquid Temperature: 22.5°C

Communication System: GSM Professional 835MHz; Frequency: 848.8 MHz ; Duty Cycle: 1:8.3

Probe: EX3DV4 - SN3754ConvF(9.41, 9.41, 9.41); Calibrated: 1/13/2017

GSM 850MHz Right Cheek High/Area Scan (11x71x1):

Measurement grid: $dx=10 \text{ mm}$, $dy=10 \text{ mm}$

Maximum value of SAR (Measurement) = 0.347 W/kg

GSM 850MHz Right Cheek High/Zoom Scan (7x7x7)/Cube 0:

Measurement grid: $dx=5\text{mm}$, $dy=5\text{mm}$, $dz=5\text{mm}$

Reference Value = 5.819 V/m ; Power Drift = 0.14 dB

Peak SAR (extrapolated) = 0.402 W/kg

SAR(1 g) = 0.328 W/kg ; SAR(10 g) = 0.245 W/kg

Maximum value of SAR (measured) = 0.345 W/kg

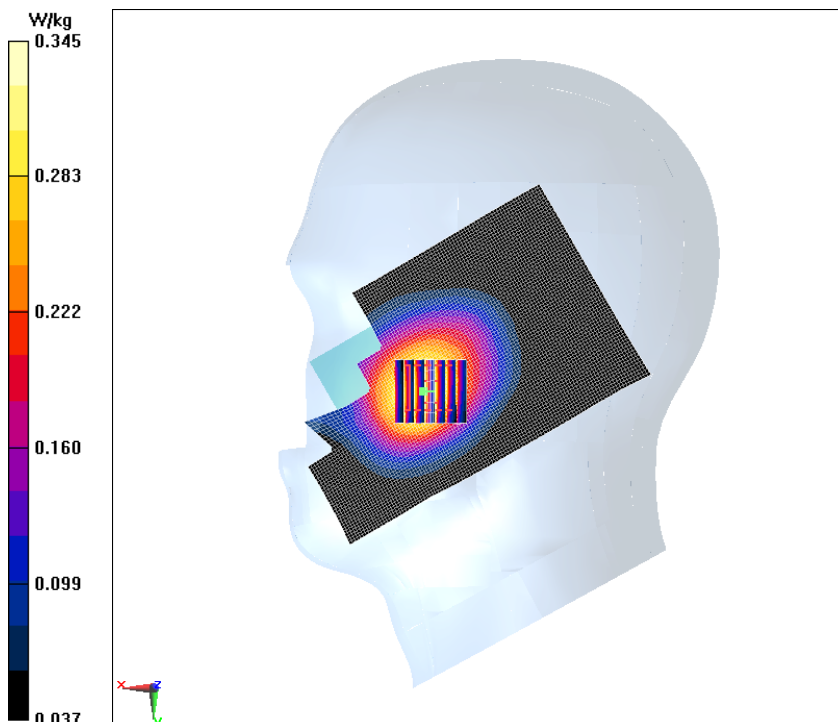

Fig.1 GSM 850MHz Right Cheek High

GSM 850MHz Ground Mode High

Date/Time: 2017/4/13

Electronics: DAE4 Sn1244

Medium: Body 850MHz

Medium parameters used: $f = 849 \text{ MHz}$; $\sigma = 1.008 \text{ S/m}$; $\epsilon_r = 55.069$; $\rho = 1000 \text{ kg/m}^3$

Ambient Temperature: 22.5°C Liquid Temperature: 22.5°C

Communication System: GSM 850MHz GPRS 4TS (0); Frequency: 848.8 MHz; Duty Cycle: 1:2

Probe: EX3DV4 - SN3754ConvF(9.66, 9.66, 9.66); Calibrated: 1/13/2017

GSM 850MHz Ground Mode High/Area Scan (71x111x1):

Measurement grid: $dx=10 \text{ mm}$, $dy=10 \text{ mm}$

Maximum value of SAR (Measurement) = 0.801 W/kg

GSM 850MHz Ground Mode High/Zoom Scan (7x7x7)/Cube 0:

Measurement grid: $dx=5\text{mm}$, $dy=5\text{mm}$, $dz=5\text{mm}$

Reference Value = 26.28 V/m; Power Drift = 0.05 dB

Peak SAR (extrapolated) = 1.02 W/kg

SAR(1 g) = 0.790 W/kg; SAR(10 g) = 0.580 W/kg

Maximum value of SAR (measured) = 0.837 W/kg

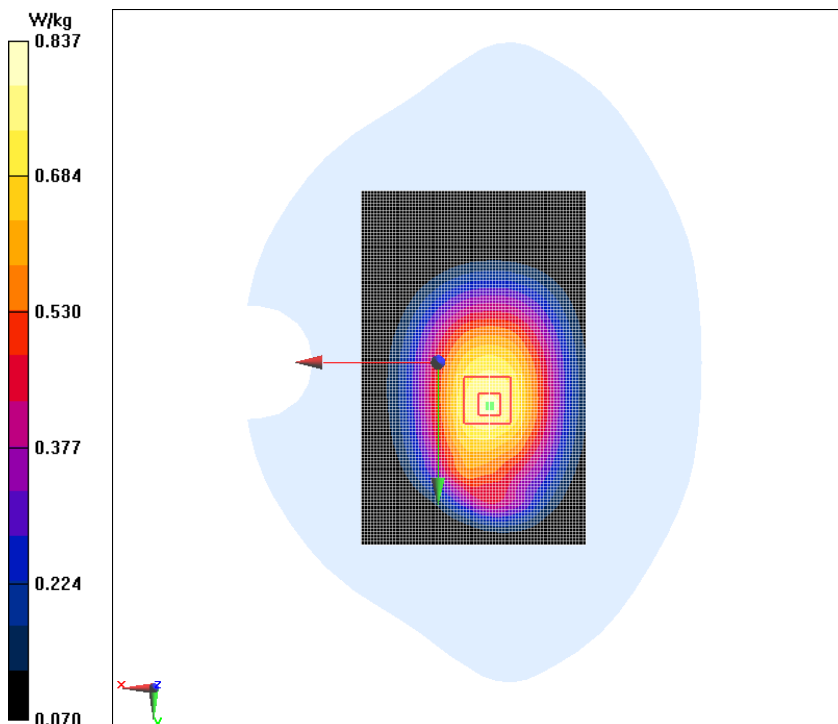

Fig.2 GSM 850MHz Ground Mode High

GSM 850MHz Ground Mode High Repeated

Date/Time: 2017/4/13

Electronics: DAE4 Sn1244

Medium: Body 850MHz

Medium parameters used: $f = 849 \text{ MHz}$; $\sigma = 1.008 \text{ S/m}$; $\epsilon_r = 55.069$; $\rho = 1000 \text{ kg/m}^3$

Ambient Temperature: 22.5°C Liquid Temperature: 22.5°C

Communication System: GSM 850MHz GPRS 4TS (0); Frequency: 848.8 MHz; Duty Cycle: 1:2

Probe: EX3DV4 - SN3754ConvF(9.66, 9.66, 9.66); Calibrated: 1/13/2017

GSM 850MHz Ground Mode High Repeated /Area Scan (71x111x1):

Measurement grid: $dx=10 \text{ mm}$, $dy=10 \text{ mm}$

Maximum value of SAR (Measurement) = 0.851 W/kg

GSM 850MHz Ground Mode High Repeated /Zoom Scan (7x7x7)/Cube 0:

Measurement grid: $dx=5\text{mm}$, $dy=5\text{mm}$, $dz=5\text{mm}$

Reference Value = 26.86 V/m; Power Drift = -0.12 dB

Peak SAR (extrapolated) = 1.04 W/kg

SAR(1 g) = 0.795 W/kg; SAR(10 g) = 0.586 W/kg

Maximum value of SAR (measured) = 0.836 W/kg

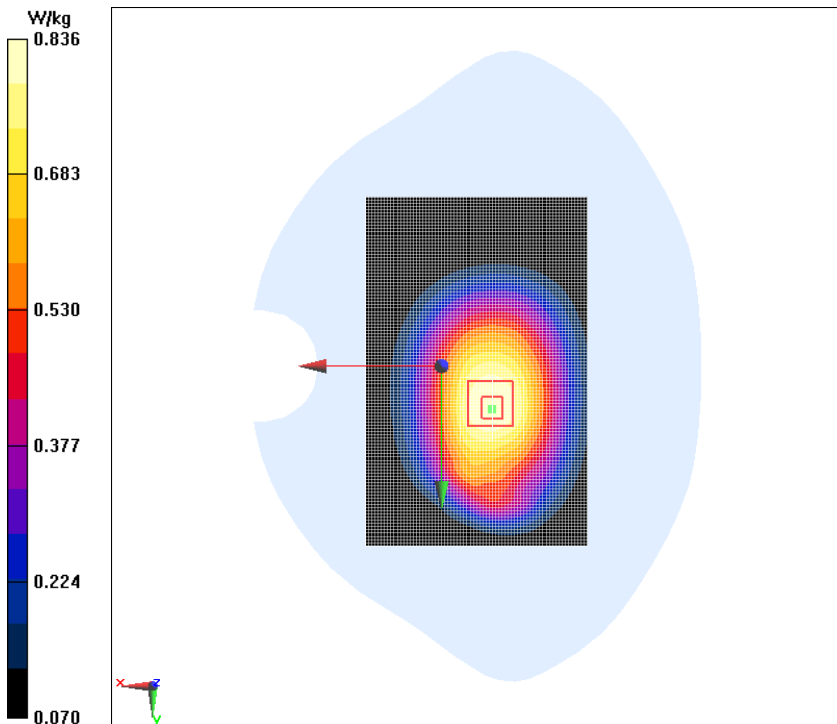

Fig.3 GSM 850MHz Ground Mode High Repeated

GSM 1900MHz Left Cheek Low

Date/Time: 2017/4/13

Electronics: DAE4 Sn1244

Medium: Head 1900MHz

Medium parameters used: $f = 1850.2$ MHz; $\sigma = 1.348$ S/m; $\epsilon_r = 40.172$; $\rho = 1000$ kg/m³

Ambient Temperature: 22.5°C Liquid Temperature: 22.5°C

Communication System: GSM Professional 1900MHz; Frequency: 1850.2 MHz; Duty Cycle: 1:8.3

Probe: EX3DV4 - SN3754ConvF(7.85, 7.85, 7.85); Calibrated: 1/13/2017

GSM 1900MHz Left Cheek Low/Area Scan (101x61x1):

Measurement grid: dx=10 mm, dy=10 mm

Maximum value of SAR (Measurement) = 1.02 W/kg

GSM 1900MHz Left Cheek Low/Zoom Scan (7x7x7)/Cube 0:

Measurement grid: dx=5mm, dy=5mm, dz=5mm

Reference Value = 5.941 V/m; Power Drift = 0.11 dB

Peak SAR (extrapolated) = 1.45 W/kg

SAR(1 g) = 0.905 W/kg; SAR(10 g) = 0.531 W/kg

Maximum value of SAR (measured) = 1.00 W/kg

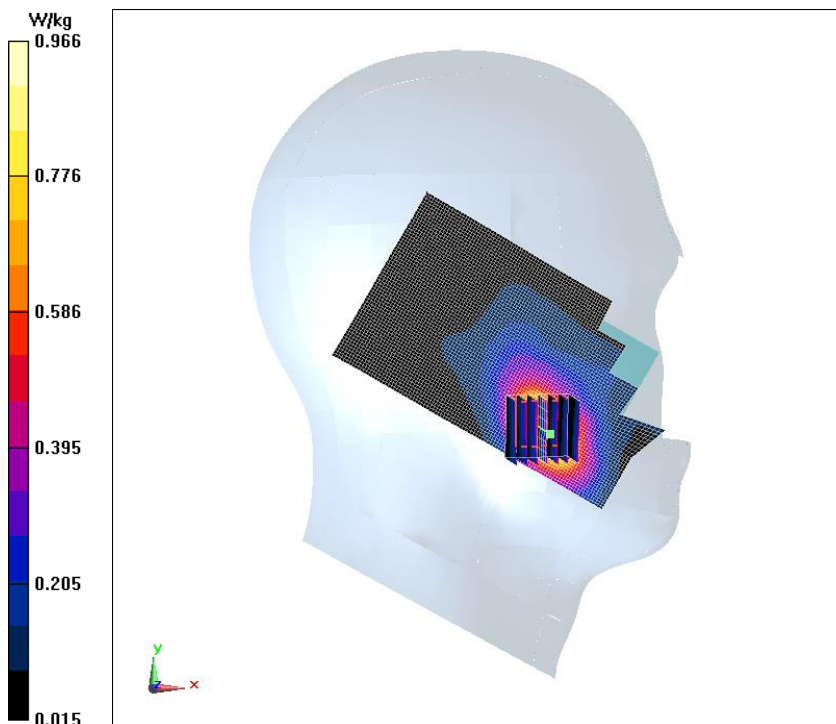

Fig.4 GSM 1900MHz Left Cheek Low

GSM 1900MHz Left Cheek Low Repeated

Date/Time: 2017/4/13

Electronics: DAE4 Sn1244

Medium: Head 1900MHz

Medium parameters used: $f = 1850.2$ MHz; $\sigma = 1.348$ S/m; $\epsilon_r = 40.172$; $\rho = 1000$ kg/m³

Ambient Temperature: 22.5°C Liquid Temperature: 22.5°C

Communication System: GSM Professional 1900MHz; Frequency: 1850.2 MHz; Duty Cycle: 1:8.3

Probe: EX3DV4 - SN3754ConvF(7.85, 7.85, 7.85); Calibrated: 1/13/2017

GSM 1900MHz Left Cheek Low Repeated/Area Scan (101x61x1):

Measurement grid: dx=10 mm, dy=10 mm

Maximum value of SAR (Measurement) = 1.00 W/kg

GSM 1900MHz Left Cheek Low Repeated/Zoom Scan (7x7x7)/Cube 0:

Measurement grid: dx=5mm, dy=5mm, dz=5mm

Reference Value = 6.391 V/m; Power Drift = 0.06 dB

Peak SAR (extrapolated) = 1.42 W/kg

SAR(1 g) = 0.887 W/kg; SAR(10 g) = 0.523 W/kg

Maximum value of SAR (measured) = 0.966 W/kg

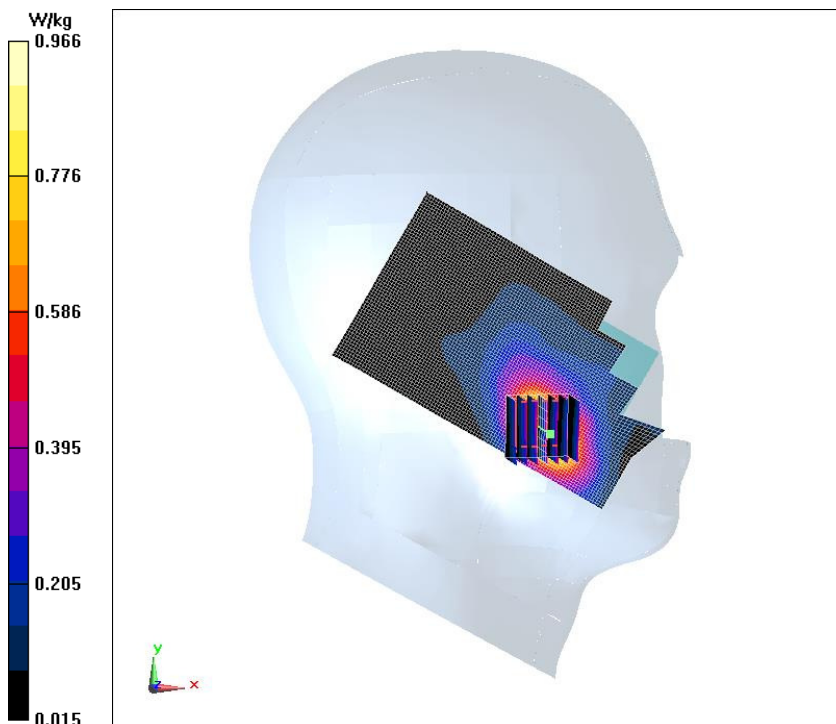

Fig.5 GSM 1900MHz Left Cheek Low Repeated

GSM 1900MHz Ground Mode High

Date/Time: 2017/4/13

Electronics: DAE4 Sn1244

Medium: Body 1900MHz

Medium parameters used: $f = 1910 \text{ MHz}$; $\sigma = 1.521 \text{ S/m}$; $\epsilon_r = 53.443$; $\rho = 1000 \text{ kg/m}^3$

Ambient Temperature: 22.5°C Liquid Temperature: 22.5°C

Communication System: GSM 1900MHz GPRS 4TS (0); Frequency: 1909.8 MHz; Duty Cycle: 1:2

Probe: EX3DV4 - SN3754ConvF(7.6, 7.6, 7.6); Calibrated: 1/13/2017

GSM 1900MHz Ground Mode High/Area Scan (71x111x1):

Measurement grid: $dx=10 \text{ mm}$, $dy=10 \text{ mm}$

Maximum value of SAR (Measurement) = 0.958 W/kg

GSM 1900MHz Ground Mode High/Zoom Scan (7x7x7)/Cube 0:

Measurement grid: $dx=5\text{mm}$, $dy=5\text{mm}$, $dz=5\text{mm}$

Reference Value = 10.44 V/m; Power Drift = 0.15 dB

Peak SAR (extrapolated) = 1.55 W/kg

SAR(1 g) = 0.878 W/kg; SAR(10 g) = 0.502 W/kg

Maximum value of SAR (measured) = 0.956 W/kg

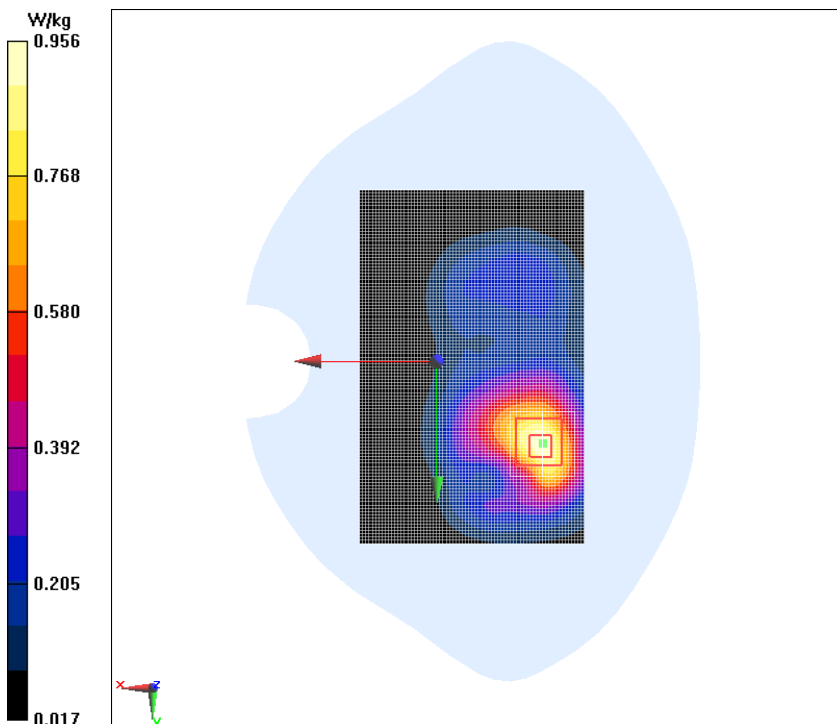

Fig.6 GSM 1900MHz Ground Mode High

GSM 1900MHz Ground Mode High Repeated

Date/Time: 2017/4/13

Electronics: DAE4 Sn1244

Medium: Body 1900MHz

Medium parameters used: $f = 1910$ MHz; $\sigma = 1.521$ S/m; $\epsilon_r = 53.443$; $\rho = 1000$ kg/m³

Ambient Temperature: 22.5°C Liquid Temperature: 22.5°C

Communication System: GSM 1900MHz GPRS 4TS (0); Frequency: 1909.8 MHz; Duty Cycle: 1:2

Probe: EX3DV4 - SN3754ConvF(7.6, 7.6, 7.6); Calibrated: 1/13/2017

GSM 1900MHz Ground Mode High Repeated/Area Scan (71x111x1):

Measurement grid: dx=10 mm, dy=10 mm

Maximum value of SAR (Measurement) = 0.967 W/kg

GSM 1900MHz Ground Mode High Repeated/Zoom Scan (7x7x7)/Cube 0:

Measurement grid: dx=5mm, dy=5mm, dz=5mm

Reference Value = 10.43 V/m; Power Drift = 0.15 dB

Peak SAR (extrapolated) = 1.55 W/kg

SAR(1 g) = 0.888 W/kg; SAR(10 g) = 0.507 W/kg

Maximum value of SAR (measured) = 0.970 W/kg

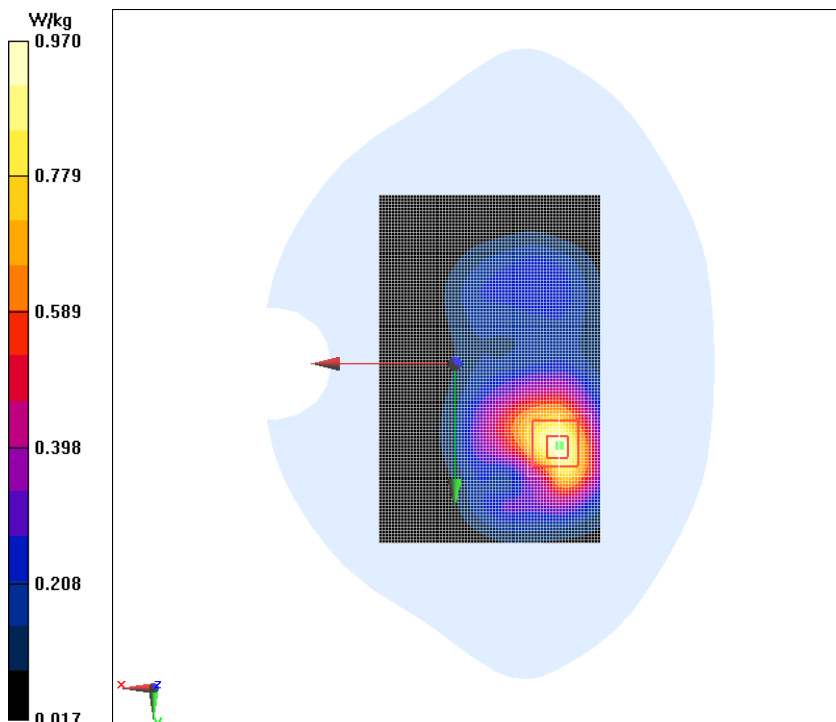

Fig.7 GSM 1900MHz Ground Mode High Repeated

WiFi 802.11b Right Cheek Low

Date/Time: 2017/4/13

Electronics: DAE4 Sn1244

Medium: Head 2450MHz

Medium parameters used: $f = 2412 \text{ MHz}$; $\sigma = 1.753 \text{ S/m}$; $\epsilon_r = 39.865$; $\rho = 1000 \text{ kg/m}^3$

Ambient Temperature: 22.5°C Liquid Temperature: 22.5°C

Communication System: Wifi 2450 2450MHz; Frequency: 2412 MHz; Duty Cycle: 1:1

Probe: EX3DV4 - SN3754ConvF(7.26, 7.26, 7.26); Calibrated: 1/13/2017

WiFi 802.11b Right Cheek Low/Area Scan (111x71x1):

Measurement grid: $dx=10 \text{ mm}$, $dy=10 \text{ mm}$

Maximum value of SAR (Measurement) = 0.703 W/kg

WiFi 802.11b Right Cheek Low/Zoom Scan (7x7x7)/Cube 0:

Measurement grid: $dx=5\text{mm}$, $dy=5\text{mm}$, $dz=5\text{mm}$

Reference Value = 6.996 V/m; Power Drift = 0.07 dB

Peak SAR (extrapolated) = 1.69 W/kg

SAR(1 g) = 0.659 W/kg; SAR(10 g) = 0.281 W/kg

Maximum value of SAR (measured) = 0.731 W/kg

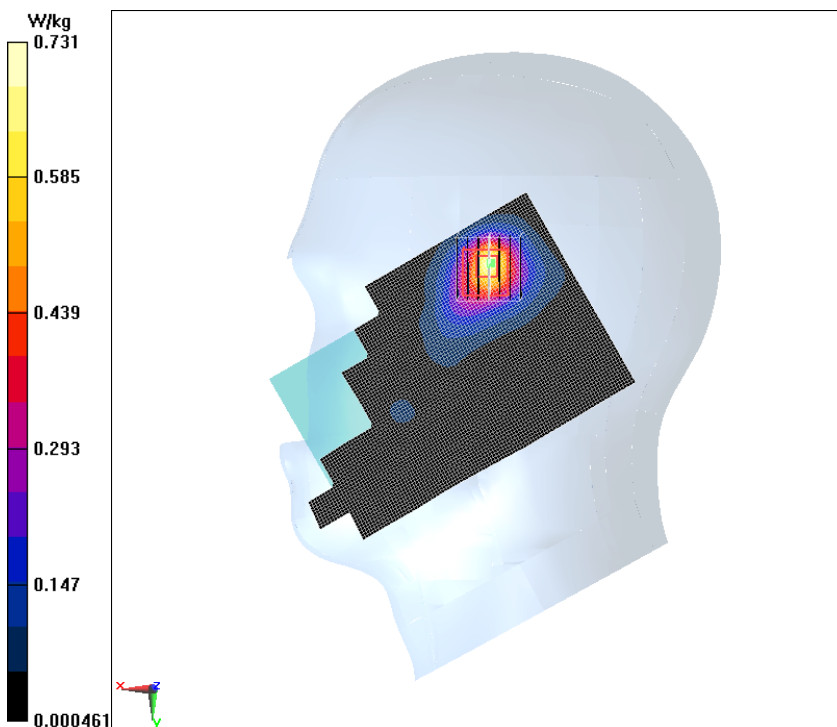

Fig.8 WiFi 802.11b Right Cheek Low

WiFi 802.11b Phantom Mode Middle

Date/Time: 2017/4/13

Electronics: DAE4 Sn1244

Medium: Body 2450MHz

Medium parameters used: $f = 2437$ MHz; $\sigma = 1.915$ S/m; $\epsilon_r = 53.326$; $\rho = 1000$ kg/m³

Ambient Temperature:22.5°C Liquid Temperature:22.5°C

Communication System: Wifi 2450 2450MHz; Frequency: 2437 MHz; Duty Cycle: 1:1

Probe: EX3DV4 - SN3754ConvF(7.22, 7.22, 7.22); Calibrated: 1/13/2017

WiFi 802.11b Phantom Mode Middle /Area Scan (61x101x1):

Measurement grid: dx=10 mm, dy=10 mm

Maximum value of SAR (Measurement) = 0.369 W/kg

WiFi 802.11b Phantom Mode Middle /Zoom Scan (7x7x7)/Cube 0:

Measurement grid: dx=5mm, dy=5mm, dz=5mm

Reference Value = 5.294 V/m; Power Drift = 0.03 dB

Peak SAR (extrapolated) = 0.727 W/kg

SAR(1 g) = 0.305 W/kg; SAR(10 g) = 0.137 W/kg

Maximum value of SAR (measured) = 0.339 W/kg

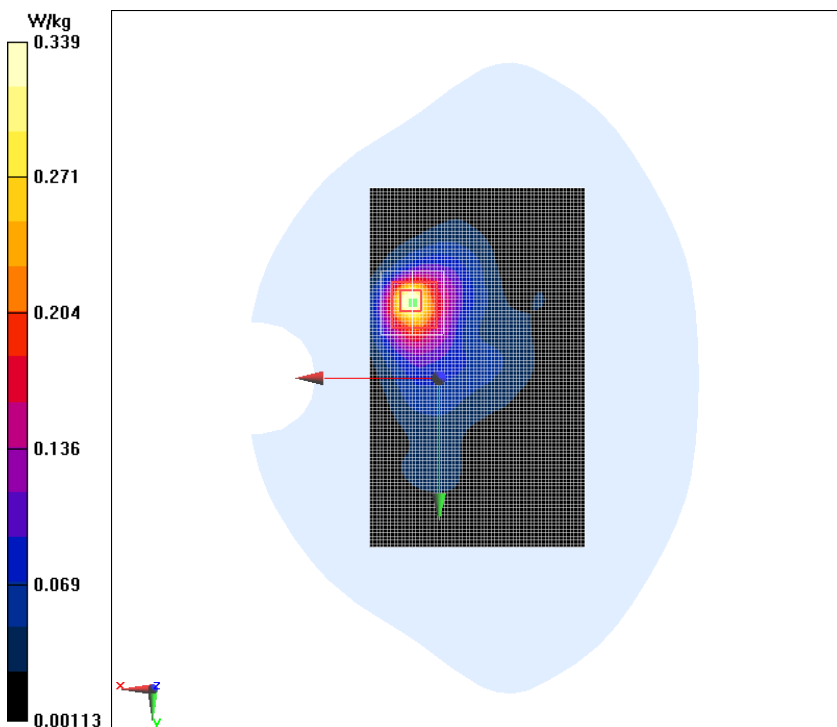

Fig.9 WiFi 802.11b Phantom Mode Middle

ANNEX B. SYSTEM VALIDATION RESULTS

835 MHz

Date/Time: 2017/4/12

Electronics: DAE4 Sn1244

Medium: Head 835MHz

Medium parameters used: $f = 835 \text{ MHz}$; $\sigma = 0.936 \text{ S/m}$; $\epsilon_r = 40.926$; $\rho = 1000 \text{ kg/m}^3$

Ambient Temperature: 22.5°C Liquid Temperature: 22.5°C

Communication System: CW 835MHz; Frequency: 835 MHz; Duty Cycle: 1:1

Probe: EX3DV4 - SN3754ConvF(9.41, 9.41, 9.41); Calibrated: 1/13/2017

System Validation /Area Scan (60x120x1):

Measurement grid: $dx=10 \text{ mm}$, $dy=10 \text{ mm}$

Maximum value of SAR (Measurement) = 2.85 W/kg

System Validation /Zoom Scan (7x7x7)/Cube 0:

Measurement grid: $dx=5\text{mm}$, $dy=5\text{mm}$, $dz=5\text{mm}$

Reference Value = 50.76 V/m; Power Drift = 0.06 dB

Peak SAR (extrapolated) = 3.14 W/kg

SAR(1 g) = 2.32W/kg; SAR(10 g) = 1.52 W/kg

Maximum value of SAR (measured) = 2.78 W/kg

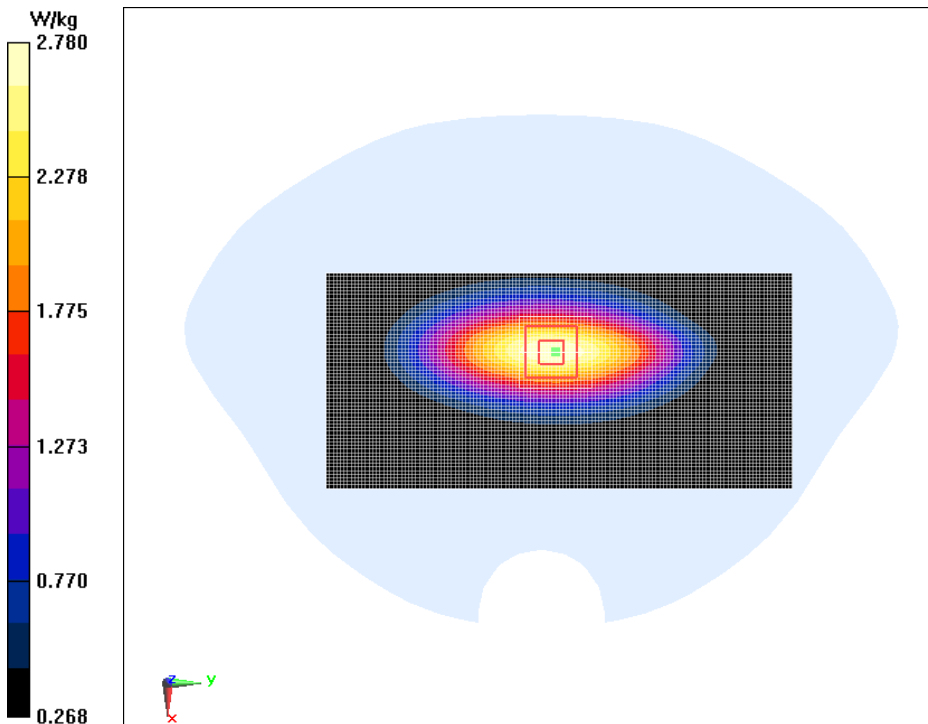

1900MHz

Date/Time: 2017/4/13

Electronics: DAE4 Sn1244

Medium: Head 1900MHz

Medium parameters used: $f = 1900 \text{ MHz}$; $\sigma = 1.372 \text{ S/m}$; $\epsilon_r = 39.422$; $\rho = 1000 \text{ kg/m}^3$

Ambient Temperature: 22.5°C Liquid Temperature: 22.5°C

Communication System: CW 1900MHz; Frequency: 1900 MHz; Duty Cycle: 1:1

Probe: EX3DV4 - SN3754ConvF(7.85, 7.85, 7.85); Calibrated: 1/13/2017

System check Validation /Area Scan (60x60x1):

Measurement grid: $dx=10 \text{ mm}$, $dy=10 \text{ mm}$

Maximum value of SAR (Measurement) = 15.3 W/kg

System check Validation /Zoom Scan (7x7x7) /Cube 0:

Measurement grid: $dx=5\text{mm}$, $dy=5\text{mm}$, $dz=5\text{mm}$

Reference Value = 104.7 V/m ; Power Drift = -0.13 dB

Peak SAR (extrapolated) = 19.1 W/kg

SAR(1 g) = 9.91 W/kg ; SAR(10 g) = 5.18 W/kg

Maximum value of SAR (measured) = 14.9 W/kg

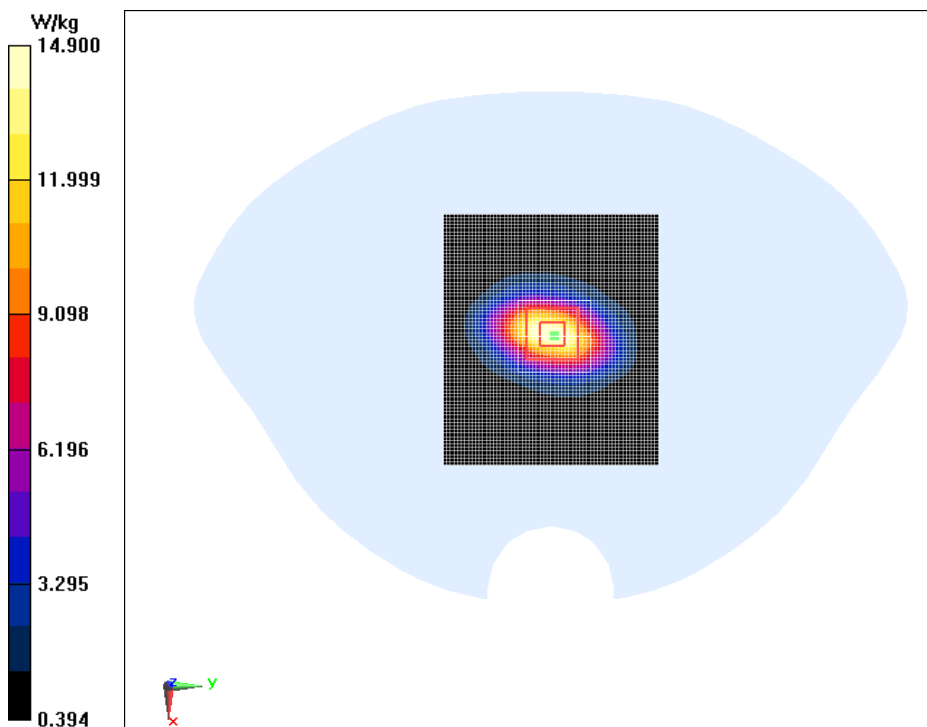

2450MHz

Date/Time: 2017/4/13

Electronics: DAE4 Sn1244

Medium: Head 2450MHz

Medium parameters used: $f = 2450 \text{ MHz}$; $\sigma = 1.789 \text{ S/m}$; $\epsilon_r = 39.588$; $\rho = 1000 \text{ kg/m}^3$

Ambient Temperature: 22.5°C Liquid Temperature: 22.5°C

Communication System: CW 2450MHz; Frequency: 2450 MHz; Duty Cycle: 1:1

Probe: EX3DV4 - SN3754ConvF(7.26, 7.26, 7.26); Calibrated: 1/13/2017

System Validation /Area Scan (40x80x1):

Measurement grid: $dx=10 \text{ mm}$, $dy=10 \text{ mm}$

Maximum value of SAR (Measurement) = 21.5 W/kg

System Validation/Zoom Scan (7x7x7) /Cube 0:

Measurement grid: $dx=5\text{mm}$, $dy=5\text{mm}$, $dz=5\text{mm}$

Reference Value = 101.6 V/m ; Power Drift = -0.15 dB

Peak SAR (extrapolated) = 26.4 W/kg

SAR(1 g) = 13.5 W/kg ; SAR(10 g) = 6.22 W/kg

Maximum value of SAR (measured) = 20.3 W/kg

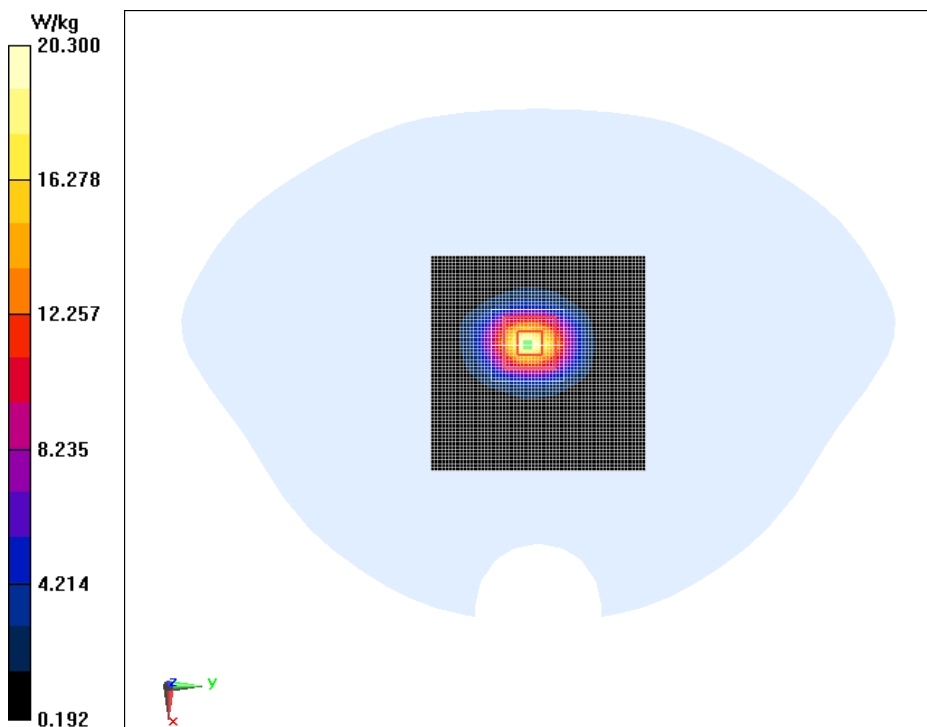

835 MHz Body

Date/Time: 2017/4/12

Electronics: DAE4 Sn1244

Medium: Body 835MHz

Medium parameters used: $f = 835 \text{ MHz}$; $\sigma = 0.998 \text{ S/m}$; $\epsilon_r = 55.084$; $\rho = 1000 \text{ kg/m}^3$

Ambient Temperature: 22.5°C Liquid Temperature: 22.5°C

Communication System: CW 850MHz; Frequency: 835 MHz; Duty Cycle: 1:1

Probe: EX3DV4 - SN3754ConvF(9.66, 9.66, 9.66); Calibrated: 1/13/2017

System Validation/Area Scan (60x120x1):

Measurement grid: $dx=10 \text{ mm}$, $dy=10 \text{ mm}$

Maximum value of SAR (Measurement) = 2.81 W/kg

System Validation/Zoom Scan(7x7x7)/Cube 0:

Measurement grid: $dx=5\text{mm}$, $dy=5\text{mm}$, $dz=5\text{mm}$

Reference Value = 54.75 V/m ; Power Drift = 0.08 dB

Peak SAR (extrapolated) = 3.52 W/kg

SAR(1 g) = 2.38 W/kg ; SAR(10 g) = 1.57 W/kg

Maximum value of SAR (measured) = 2.78 W/kg

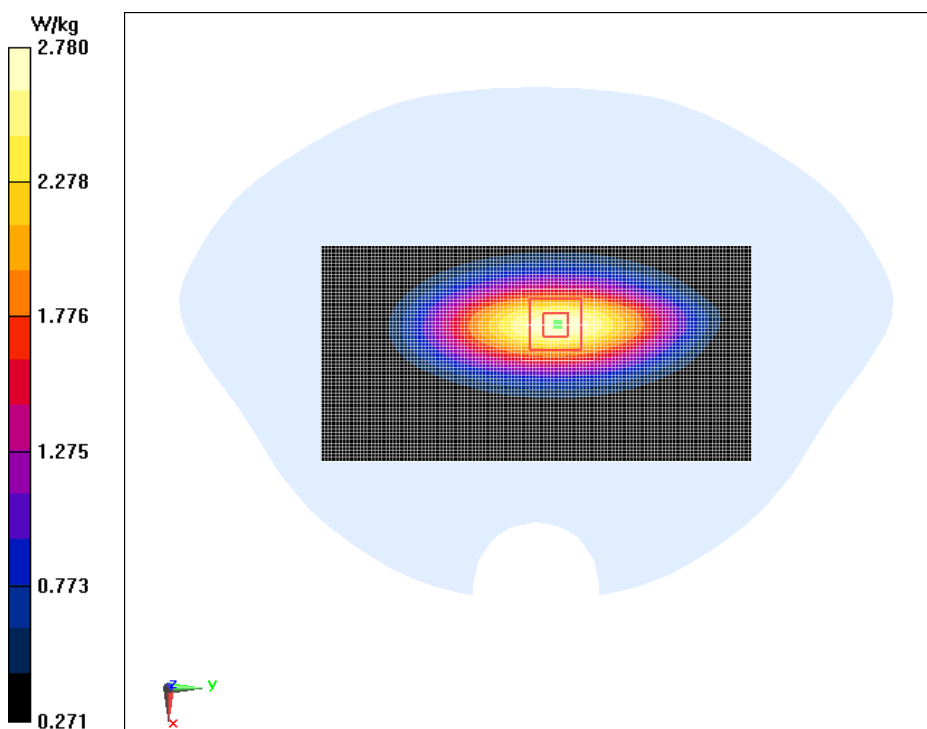

1900MHz Body

Date/Time: 2017/4/13

Electronics: DAE4 Sn1244

Medium: Body 1900MHz

Medium parameters used: $f = 1900$ MHz; $\sigma = 1.511$ S/m; $\epsilon_r = 53.451$; $\rho = 1000$ kg/m³

Ambient Temperature: 22.5°C Liquid Temperature: 22.5°C

Communication System: CW 1900MHz; Frequency: 1900 MHz; Duty Cycle: 1:1

Probe: EX3DV4 - SN3754ConvF(7.6, 7.6, 7.6); Calibrated: 1/13/2017

System Validation/Area Scan (60x90x1):

Measurement grid: dx=10 mm, dy=10 mm

Maximum value of SAR (Measurement) = 13.6 W/kg

System Validation/Zoom Scan(7x7x7)/Cube 0:

Measurement grid: dx=5mm, dy=5mm, dz=5mm

Reference Value = 88.62 V/m; Power Drift = -0.10 dB

Peak SAR (extrapolated) = 18.9 W/kg

SAR(1 g) = 10.1 W/kg; SAR(10 g) = 5.23 W/kg

Maximum value of SAR (measured) = 13.4 W/kg

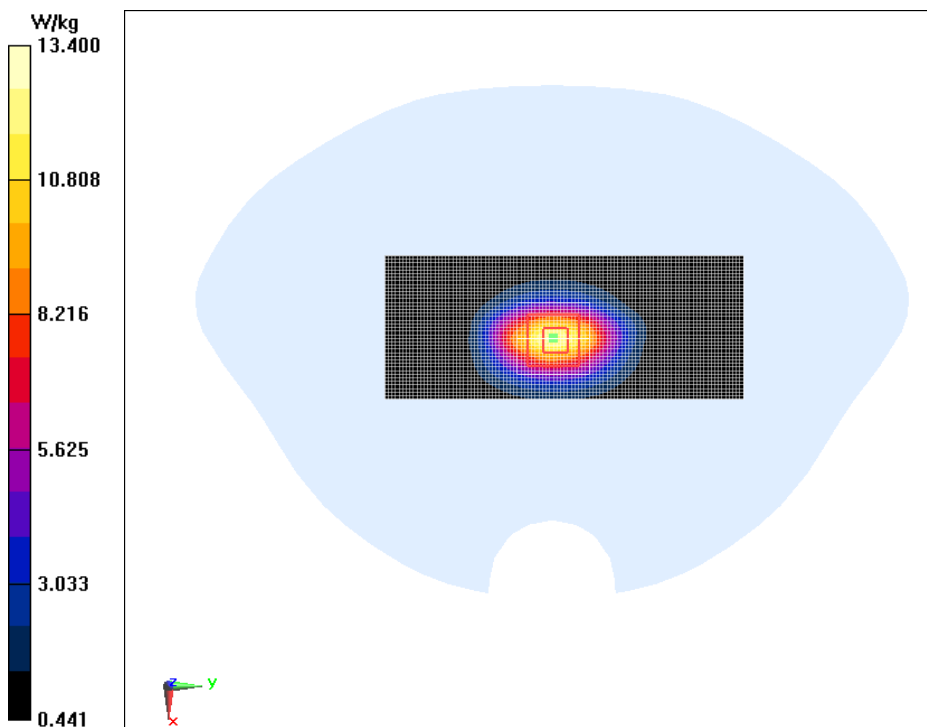

2450MHz Body

Date/Time: 2017/4/13

Electronics: DAE4 Sn1244

Medium: Body 2450 MHz

Medium parameters used: $f = 2450$ MHz; $\sigma = 1.929$ S/m; $\epsilon_r = 53.268$; $\rho = 1000$ kg/m³

Ambien Temperature: 22.5° C Liquid Temperature: 22.5° C

Communication System: CW; Frequency: 2450 MHz; Duty Cycle: 1:1

Probe: EX3DV4 - SN3754ConvF(7.22, 7.22, 7.22); Calibrated: 1/13/2017

System Validation/ Area Scan (100x100x1):

Measurement grid: dx=10mm, dy=10mm

Maximum value of SAR (measured) = 22.6 W/kg

System Validation/Zoom Scan (7x7x7)/Cube 0:

Measurement grid: dx=5mm, dy=5mm, dz=5mm

Reference Value = 103.7 V/m; Power Drift = 0.04 dB

Peak SAR (extrapolated) = 28.2 W/kg

SAR(1 g) = 13.4 W/kg; SAR(10 g) = 6.15 W/kg

Maximum value of SAR (measured) = 20.3 W/kg

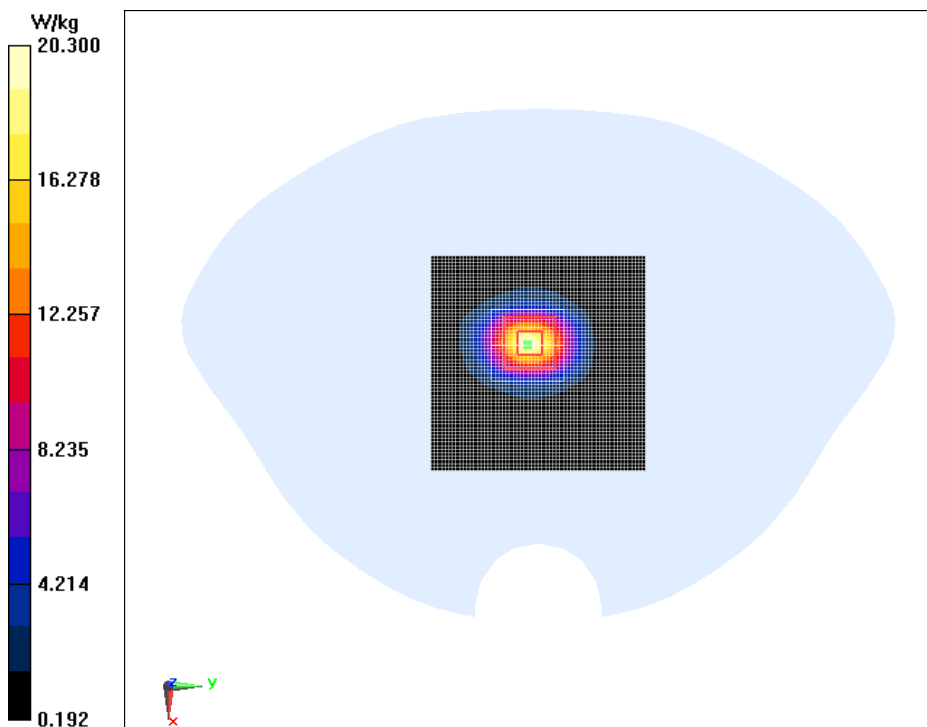

ANNEX C. SAR Measurement Setup

C.1. Measurement Set-up

The DASY5 system for performing compliance tests is illustrated above graphically. This system consists of the following items:

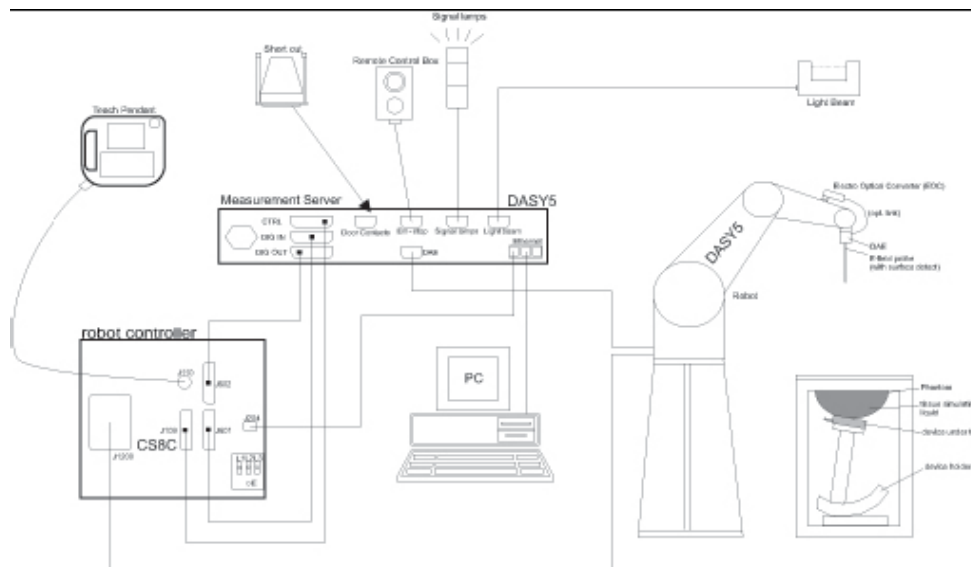

Picture C.1 SAR Lab Test Measurement Set-up

- A standard high precision 6-axis robot (Stäubli TX=RX family) with controller, teach pendant and software. An arm extension for accommodating the data acquisition electronics (DAE).
- An isotropic field probe optimized and calibrated for the targeted measurement.
- A data acquisition electronics (DAE) which performs the signal amplification, signal multiplexing, AD-conversion, offset measurements, mechanical surface detection, collision detection, etc. The unit is battery powered with standard or rechargeable batteries. The signal is optically transmitted to the EOC.
- The Electro-optical converter (EOC) performs the conversion from optical to electrical signals for the digital communication to the DAE. To use optical surface detection, a special version of the EOC is required. The EOC signal is transmitted to the measurement server.
- The function of the measurement server is to perform the time critical tasks such as signal filtering, control of the robot operation and fast movement interrupts.
- The Light Beam used is for probe alignment. This improves the (absolute) accuracy of the probe positioning.
- A computer running WinXP and the DASY5 software.
- Remote control and teach pendant as well as additional circuitry for robot safety such as

- warning lamps, etc.
- The phantom, the device holder and other accessories according to the targeted measurement.

C.2. DASY5 E-field Probe System

The SAR measurements were conducted with the dosimetric probe designed in the classical triangular configuration and optimized for dosimetric evaluation. The probe is constructed using the thick film technique; with printed resistive lines on ceramic substrates. The probe is equipped with an optical multifiber line ending at the front of the probe tip. It is connected to the EOC box on the robot arm and provides an automatic detection of the phantom surface. Half of the fibers are connected to a pulsed infrared transmitter, the other half to a synchronized receiver. As the probe approaches the surface, the reflection from the surface produces a coupling from the transmitting to the receiving fibers. This reflection increases first during the approach, reaches maximum and then decreases. If the probe is flatly touching the surface, the coupling is zero. The distance of the coupling maximum to the surface is independent of the surface reflectivity and largely independent of the surface to probe angle. The DASY5 software reads the reflection during a software approach and looks for the maximum using 2nd order curve fitting. The approach is stopped at reaching the maximum.

Probe Specifications:

Model: ES3DV3, EX3DV4

Frequency

Range: 700MHz — 2.6GHz(ES3DV3)

Calibration: In head and body simulating tissue at
Frequencies from 835 up to 2450MHz

Linearity:

± 0.2 dB(700MHz — 2.0GHz) for ES3DV3

Dynamic Range: 10 mW/kg — 100W/kg

Probe Length: 330 mm

Probe Tip

Length: 20 mm

Body Diameter: 12 mm

Tip Diameter: 2.5 mm (3.9 mm for ES3DV3)

Tip-Center: 1 mm (2.0mm for ES3DV3)

Application:SAR Dosimetry Testing

Compliance tests of mobile phones

Dosimetry in strong gradient fields



Picture C.2 Near-field Probe



Picture C.3 E-field Probe

C.3. E-field Probe Calibration

Each E-Probe/Probe Amplifier combination has unique calibration parameters. A TEM cell calibration procedure is conducted to determine the proper amplifier settings to enter in the probe parameters. The amplifier settings are determined for a given frequency by subjecting the probe to a known E-field density (1 mW/cm²) using an RF Signal generator, TEM cell, and RF Power Meter.

The free space E-field from amplified probe outputs is determined in a test chamber. This calibration can be performed in a TEM cell if the frequency is below 1 GHz and in a waveguide or other methodologies above 1 GHz for free space. For the free space calibration, the probe is placed in the volumetric center of the cavity and at the proper orientation with the field. The probe is then rotated 360 degrees until the three channels show the maximum reading. The power density readings equate to 1 mW/cm².

E-field temperature correlation calibration is performed in a flat phantom filled with the appropriate simulated brain tissue. The E-field in the medium correlates with the temperature rise in the dielectric medium. For temperature correlation calibration a RF transparent thermistor-based temperature probe is used in conjunction with the E-field probe.

$$SAR = C \frac{\Delta T}{\Delta t}$$

Where:

Δt = Exposure time (30 seconds),

C = Heat capacity of tissue (brain or muscle),

ΔT = Temperature increase due to RF exposure.

$$SAR = \frac{|E|^2 \cdot \sigma}{\rho}$$

Where:

σ = Simulated tissue conductivity,

ρ = Tissue density (kg/m³).

C.4. Other Test Equipment

C.4.1. Data Acquisition Electronics(DAE)

The data acquisition electronics consist of a highly sensitive electrometer-grade preamplifier with auto-zeroing, a channel and gain-switching multiplexer, a fast 16 bit AD-converter and a command decoder with a control logic unit. Transmission to the measurement server is accomplished through an optical downlink for data and status information, as well as an optical uplink for

commands and the clock.

The mechanical probe mounting device includes two different sensor systems for frontal and sideways probe contacts. They are used for mechanical surface detection and probe collision detection.

The input impedance of the DAE is 200 MOhm; the inputs are symmetrical and floating. Common mode rejection is above 80 dB.



PictureC.4: DAE

C.4.2. Robot

The SPEAG DASY system uses the high precision robots (DASY5: RX90L) type from Stäubli SA (France). For the 6-axis controller system, the robot controller version from Stäubli is used. The Stäubli robot series have many features that are important for our application:

- High precision (repeatability 0.02mm)
- High reliability (industrial design)
- Low maintenance costs (virtually maintenance free due to direct drive gears; no belt drives)
- Jerk-free straight movements (brushless synchron motors; no stepper motors)
- Low ELF interference (motor control fields shielded via the closed metallic construction shields)



Picture C.5 DASY 5

C.4.3. Measurement Server

The Measurement server is based on a PC/104 CPU board with CPU (DASY5: 400 MHz, Intel Celeron), chipdisk (DASY5: 128MB), RAM (DASY5: 128MB). The necessary circuits for communication with the DAE electronic box, as well as the 16 bit AD converter system for optical detection and digital I/O interface are contained on the DASY I/O board, which is directly connected to the PC/104 bus of the CPU board.

The measurement server performs all real-time data evaluation of field measurements and surface detection, controls robot movements and handles safety operation. The PC operating system cannot interfere with these time critical processes. All connections are supervised by a watchdog, and disconnection of any of the cables to the measurement server will automatically disarm the robot and disable all program-controlled robot movements. Furthermore, the measurement server is equipped with an expansion port which is reserved for future applications. Please note that this expansion port does not have a standardized pinout, and therefore only devices provided by SPEAG can be connected. Devices from any other supplier could seriously damage the measurement server.



Picture C.6 Server for DASY 5

C.4.4. Device Holder for Phantom

The SAR in the phantom is approximately inversely proportional to the square of the distance between the source and the liquid surface. For a source at 5mm distance, a positioning uncertainty of $\pm 0.5\text{mm}$ would produce a SAR uncertainty of $\pm 20\%$. Accurate device positioning is therefore crucial for accurate and repeatable measurements. The positions in which the devices must be measured are defined by the standards.

The DASY device holder is designed to cope with the different positions given in the standard. It has two scales for device rotation (with respect to the body axis) and device inclination (with respect to the line between the ear reference points). The rotation centers for both scales is the ear reference point (ERP). Thus the device needs no repositioning when changing the angles.

The DASY device holder is constructed of low-loss POM material having the following dielectric parameters: relative permittivity $\epsilon = 3$ and loss tangent $\delta = 0.02$. The amount of dielectric material has been reduced in the closest vicinity of the device, since measurements have suggested that the influence of the clamp on the test results could thus be lowered.

<Laptop Extension Kit>

The extension is lightweight and made of POM, acrylic glass and foam. It fits easily on the upper part of the Mounting Device in place of the phone positioner. The extension is fully compatible with

the Twin-SAM and ELI phantoms.



Picture C.7: Device Holder

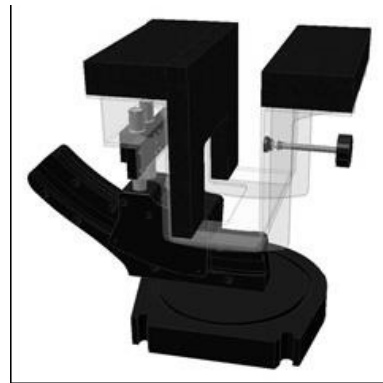

Picture C.8: Laptop Extension Kit

C.4.5. Phantom

The SAM Twin Phantom V4.0 is constructed of a fiberglass shell integrated in a table. The shape of the shell is based on data from an anatomical study designed to represent the 90th percentile of the population. The phantom enables the dissymmetric evaluation of SAR for both left and right handed handset usage, as well as body-worn usage using the flat phantom region. Reference markings on the Phantom allow the complete setup of all predefined phantom positions and measurement grids by manually teaching three points in the robot. The shell phantom has a 2mm shell thickness (except the ear region where shell thickness increases to 6 mm).

Shell Thickness: 2 ± 0.2 mm

Filling Volume: Approx. 25 liters

Dimensions: 810 x 1000 x 500 mm (H x L x W)

Available: Special



Picture C.9: SAM Twin Phantom

ANNEX D. Position of the wireless device in relation to the phantom

D.1. General considerations

This standard specifies two handset test positions against the head phantom – the “cheek” position and the “tilt” position.

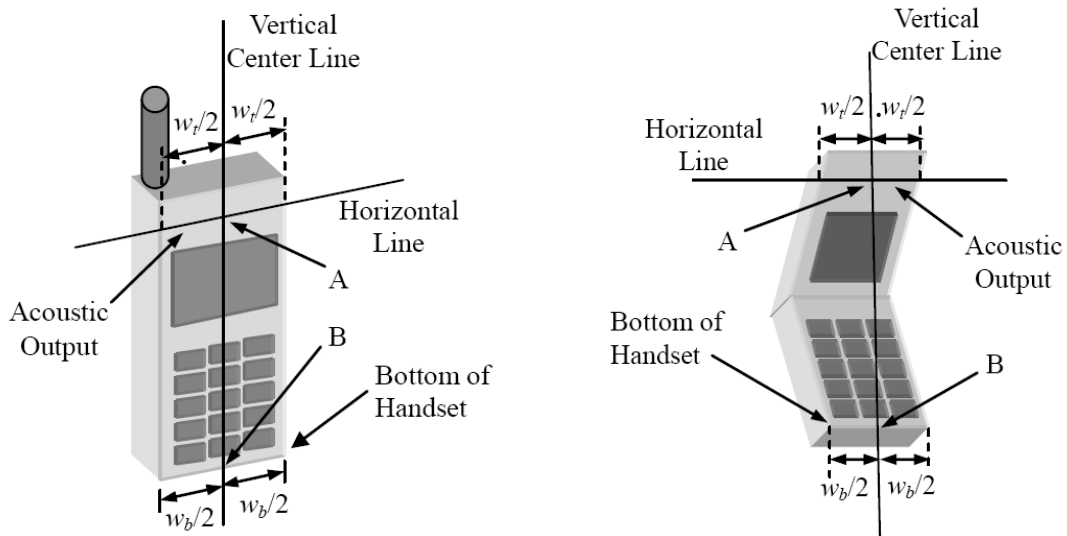

- w_t Width of the handset at the level of the acoustic
- w_b Width of the bottom of the handset
- A Midpoint of the width w_t of the handset at the level of the acoustic output
- B Midpoint of the width w_b of the bottom of the handset

Picture D.1-a Typical “fixed” case handset Picture D.1-b Typical “clam-shell” case handset

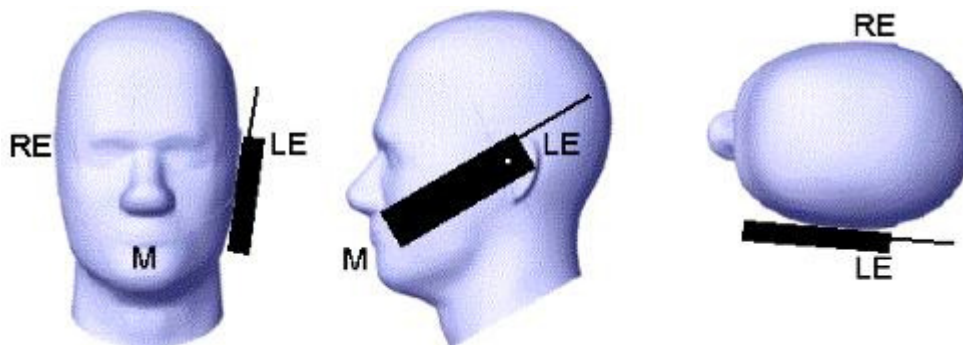

Picture D.2 Cheek position of the wireless device on the left side of SAM

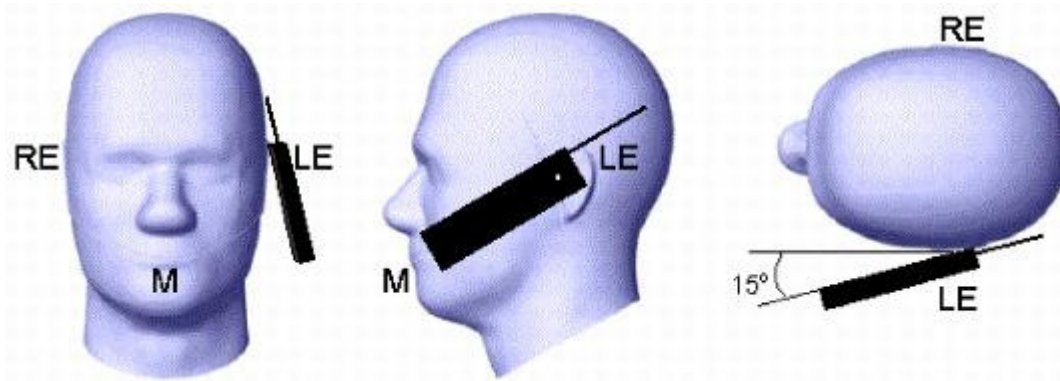

Picture D.3 Tilt position of the wireless device on the left side of SAM

D.2. Body-worn device

A typical example of a body-worn device is a mobile phone, wireless enabled PDA or other battery operated wireless device with the ability to transmit while mounted on a person's body using a carry accessory approved by the wireless device manufacturer.

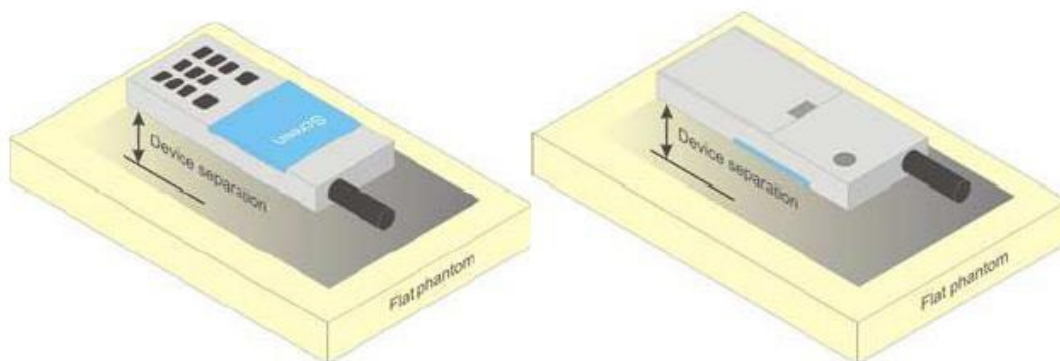

Picture D.4 Test positions for body-worn devices

D.3. Desktop device

A typical example of a desktop device is a wireless enabled desktop computer placed on a table or desk when used.

The DUT shall be positioned at the distance and in the orientation to the phantom that corresponds to the intended use as specified by the manufacturer in the user instructions. For devices that employ an external antenna with variable positions, tests shall be performed for all antenna positions specified. Picture 8.5 show positions for desktop device SAR tests. If the intended use is not specified, the device shall be tested directly against the flat phantom.

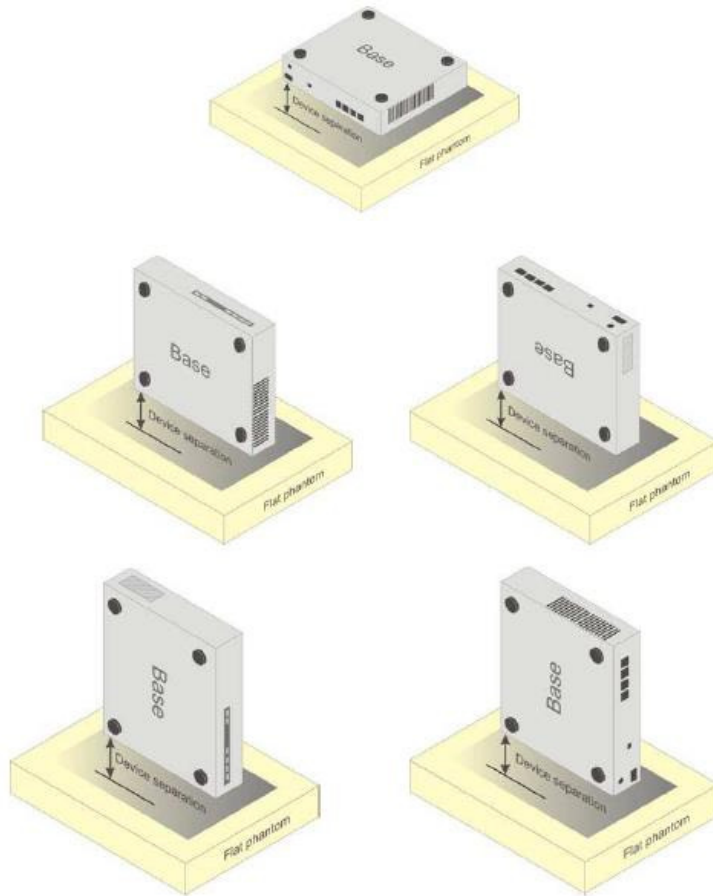

Picture D.5 Test positions for desktop devices

D.4. DUT Setup Photos



Picture D.6 DSY5 system Set-up

Note:

The photos of test sample and test positions show in additional document.

ANNEX E. Equivalent Media Recipes

The liquid used for the frequency range of 800-3000 MHz consisted of water, sugar, salt, preventol, glycol monobutyl and Cellulose. The liquid has been previously proven to be suited for worst-case. The Table E.1 shows the detail solution. It's satisfying the latest tissue dielectric parameters requirements proposed by the IEEE 1528 and IEC 62209.

Table E.1: Composition of the Tissue Equivalent Matter

Frequency (MHz)	835 Head	835 Body	1900 Head	1900 Body	2450 Head	2450 Body
Ingredients (% by weight)						
Water	41.45	52.5	55.242	69.91	58.79	72.60
Sugar	56.0	45.0	\	\	\	\
Salt	1.45	1.4	0.306	0.13	0.06	0.18
Preventol	0.1	0.1	\	\	\	\
Cellulose	1.0	1.0	\	\	\	\
Glycol Monobutyl	\	\	44.452	29.96	41.15	27.22
Dielectric Parameters	$\epsilon=41.5$	$\epsilon=55.2$	$\epsilon=40.0$	$\epsilon=53.3$	$\epsilon=39.2$	$\epsilon=52.7$
Target Value	$\sigma=0.90$	$\sigma=0.97$	$\sigma=1.40$	$\sigma=1.52$	$\sigma=1.80$	$\sigma=1.95$

ANNEX F. System Validation

The SAR system must be validated against its performance specifications before it is deployed. When SAR probes, system components or software are changed, upgraded or recalibrated, these must be validated with the SAR system(s) that operates with such components.

Table F.1: System Validation Part 1

System No.	Probe SN.	Liquid name	Validation date	Frequency point	Permittivity ϵ	Conductivity σ (S/m)
1	3754	Head 835MHz	Apr 12, 2017	835MHz	40.926	0.936
2	3754	Head 1900MHz	Apr 13, 2017	1900MHz	39.422	1.372
3	3754	Head 2450MHz	Apr 13, 2017	2450MHz	39.588	1.789
4	3754	Body 835MHz	Apr 12, 2017	835MHz	55.084	0.998
5	3754	Body 1900MHz	Apr 13, 2017	1900MHz	53.451	1.511
6	3754	Body 2450MHz	Apr 13, 2017	2450MHz	53.268	1.929

Table F.2: System Validation Part 2

CW Validation	Sensitivity	PASS	PASS
	Probe linearity	PASS	PASS
	Probe Isotropy	PASS	PASS
Mod Validation	MOD.type	GMSK	GMSK
	MOD.type	OFDM	OFDM
	Duty factor	PASS	PASS
	PAR	PASS	PASS

ANNEX G. Probe and DAE Calibration Certificate

Schmid & Partner Engineering AG

s p e a g

Zeughausstrasse 43, 8004 Zurich, Switzerland
Phone +41 44 245 9700, Fax +41 44 245 9779
info@speag.com, http://www.speag.com

1244

IMPORTANT NOTICE

USAGE OF THE DAE 4

The DAE unit is a delicate, high precision instrument and requires careful treatment by the user. There are no serviceable parts inside the DAE. Special attention shall be given to the following points:

Battery Exchange: The battery cover of the DAE4 unit is closed using a screw, over tightening the screw may cause the threads inside the DAE to wear out.

Shipping of the DAE: Before shipping the DAE to SPEAG for calibration, remove the batteries and pack the DAE in an antistatic bag. This antistatic bag shall then be packed into a larger box or container which protects the DAE from impacts during transportation. The package shall be marked to indicate that a fragile instrument is inside.

E-Stop Failures: Touch detection may be malfunctioning due to broken magnets in the E-stop. Rough handling of the E-stop may lead to damage of these magnets. Touch and collision errors are often caused by dust and dirt accumulated in the E-stop. To prevent E-stop failure, the customer shall always mount the probe to the DAE carefully and keep the DAE unit in a non-dusty environment if not used for measurements.

Repair: Minor repairs are performed at no extra cost during the annual calibration. However, SPEAG reserves the right to charge for any repair especially if rough unprofessional handling caused the defect.

DASY Configuration Files: Since the exact values of the DAE input resistances, as measured during the calibration procedure of a DAE unit, are not used by the DASY software, a nominal value of 200 MOhm is given in the corresponding configuration file.

Important Note:

Warranty and calibration is void if the DAE unit is disassembled partly or fully by the Customer.

Important Note:

Never attempt to grease or oil the E-stop assembly. Cleaning and readjusting of the E-stop assembly is allowed by certified SPEAG personnel only and is part of the annual calibration procedure.

Important Note:

To prevent damage of the DAE probe connector pins, use great care when installing the probe to the DAE. Carefully connect the probe with the connector notch oriented in the mating position. Avoid any rotational movement of the probe body versus the DAE while turning the locking nut of the connector. The same care shall be used when disconnecting the probe from the DAE.

Schmid & Partner Engineering

TN_BR040315AD DAE4.doc

11.12.2009

**Calibration Laboratory of
Schmid & Partner
Engineering AG**
Zeughausstrasse 43, 8004 Zurich, Switzerland



S Schweizerischer Kalibrierdienst
C Service suisse d'étalonnage
S Servizio svizzero di taratura
S Swiss Calibration Service

Accredited by the Swiss Accreditation Service (SAS)
The Swiss Accreditation Service is one of the signatories to the EA
Multilateral Agreement for the recognition of calibration certificates

Accreditation No.: **SCS 0108**

Client **TMC - SH (Auden)**

Certificate No: **DAE4-1244_Dec16**

CALIBRATION CERTIFICATE

Object **DAE4 - SD 000 D04 BM - SN: 1244**

Calibration procedure(s) **QA CAL-06.v29
Calibration procedure for the data acquisition electronics (DAE)**



Calibration date: **December 12, 2016**

This calibration certificate documents the traceability to national standards, which realize the physical units of measurements (SI).
The measurements and the uncertainties with confidence probability are given on the following pages and are part of the certificate.

All calibrations have been conducted in the closed laboratory facility: environment temperature (22 ± 3)°C and humidity < 70%.

Calibration Equipment used (M&TE critical for calibration)

Primary Standards	ID #	Cal Date (Certificate No.)	Scheduled Calibration
Keithley Multimeter Type 2001	SN: 0810278	09-Sep-16 (No:19065)	Sep-17
Secondary Standards	ID #	Check Date (in house)	Scheduled Check
Auto DAE Calibration Unit	SE UWS 053 AA 1001	05-Jan-16 (in house check)	In house check: Jan-17
Calibrator Box V2.1	SE UMS 006 AA 1002	05-Jan-16 (in house check)	In house check: Jan-17

	Name	Function	Signature
Calibrated by:	Dominique Steffen	Technician	
Approved by:	Fin Bomholt	Deputy Technical Manager	

Issued: December 13, 2016

This calibration certificate shall not be reproduced except in full without written approval of the laboratory.

Calibration Laboratory of
Schmid & Partner
Engineering AG
Zeughausstrasse 43, 8004 Zurich, Switzerland



S Schweizerischer Kalibrierdienst
C Service suisse d'étalonnage
S Servizio svizzero di taratura
S Swiss Calibration Service

Accredited by the Swiss Accreditation Service (SAS)
The Swiss Accreditation Service is one of the signatories to the EA
Multilateral Agreement for the recognition of calibration certificates

Accreditation No.: **SCS 0108**

Glossary

DAE data acquisition electronics
Connector angle information used in DASY system to align probe sensor X to the robot coordinate system.

Methods Applied and Interpretation of Parameters

- **DC Voltage Measurement:** Calibration Factor assessed for use in DASY system by comparison with a calibrated instrument traceable to national standards. The figure given corresponds to the full scale range of the voltmeter in the respective range.
- **Connector angle:** The angle of the connector is assessed measuring the angle mechanically by a tool inserted. Uncertainty is not required.
- The following parameters as documented in the Appendix contain technical information as a result from the performance test and require no uncertainty.
 - **DC Voltage Measurement Linearity:** Verification of the Linearity at +10% and -10% of the nominal calibration voltage. Influence of offset voltage is included in this measurement.
 - **Common mode sensitivity:** Influence of a positive or negative common mode voltage on the differential measurement.
 - **Channel separation:** Influence of a voltage on the neighbor channels not subject to an input voltage.
 - **AD Converter Values with inputs shorted:** Values on the internal AD converter corresponding to zero input voltage
 - **Input Offset Measurement:** Output voltage and statistical results over a large number of zero voltage measurements.
 - **Input Offset Current:** Typical value for information; Maximum channel input offset current, not considering the input resistance.
 - **Input resistance:** Typical value for information: DAE input resistance at the connector, during internal auto-zeroing and during measurement.
 - **Low Battery Alarm Voltage:** Typical value for information. Below this voltage, a battery alarm signal is generated.
 - **Power consumption:** Typical value for information. Supply currents in various operating modes.

DC Voltage Measurement

A/D - Converter Resolution nominal

High Range: 1LSB = 6.1 μ V, full range = -100...+300 mV

Low Range: 1LSB = 61nV, full range = -1.....+3mV

DASY measurement parameters: Auto Zero Time: 3 sec; Measuring time: 3 sec

Calibration Factors	X	Y	Z
High Range	403.872 \pm 0.02% (k=2)	403.613 \pm 0.02% (k=2)	404.527 \pm 0.02% (k=2)
Low Range	3.95409 \pm 1.50% (k=2)	3.97148 \pm 1.50% (k=2)	3.98215 \pm 1.50% (k=2)

Connector Angle

Connector Angle to be used in DASY system	22.0 \pm 1 $^{\circ}$
---	-------------------------

Appendix (Additional assessments outside the scope of SCS0108)

1. DC Voltage Linearity

High Range	Reading (μV)	Difference (μV)	Error (%)
Channel X + Input	199995.09	-0.83	-0.00
Channel X + Input	20004.47	2.58	0.01
Channel X - Input	-19997.82	2.60	-0.01
Channel Y + Input	199993.65	-2.29	-0.00
Channel Y + Input	20001.27	-0.51	-0.00
Channel Y - Input	-19997.58	2.97	-0.01
Channel Z + Input	199992.15	-3.40	-0.00
Channel Z + Input	19999.95	-1.78	-0.01
Channel Z - Input	-20002.51	-1.92	0.01

Low Range	Reading (μV)	Difference (μV)	Error (%)
Channel X + Input	2002.00	0.39	0.02
Channel X + Input	202.04	0.13	0.07
Channel X - Input	-197.82	0.13	-0.06
Channel Y + Input	2000.90	-0.59	-0.03
Channel Y + Input	202.65	0.73	0.36
Channel Y - Input	-197.74	0.13	-0.06
Channel Z + Input	2001.79	0.42	0.02
Channel Z + Input	200.75	-1.05	-0.52
Channel Z - Input	-199.15	-1.06	0.53

2. Common mode sensitivity

DASY measurement parameters: Auto Zero Time: 3 sec; Measuring time: 3 sec

	Common mode Input Voltage (mV)	High Range Average Reading (μV)	Low Range Average Reading (μV)
Channel X	200	-3.59	-5.16
	-200	6.94	5.14
Channel Y	200	-3.41	-3.57
	-200	2.60	2.96
Channel Z	200	-8.21	-8.18
	-200	5.71	5.56

3. Channel separation

DASY measurement parameters: Auto Zero Time: 3 sec; Measuring time: 3 sec

	Input Voltage (mV)	Channel X (μV)	Channel Y (μV)	Channel Z (μV)
Channel X	200	-	1.06	-4.10
Channel Y	200	7.19	-	1.88
Channel Z	200	9.77	4.29	-

4. AD-Converter Values with inputs shorted

DASY measurement parameters: Auto Zero Time: 3 sec; Measuring time: 3 sec

	High Range (LSB)	Low Range (LSB)
Channel X	16885	16322
Channel Y	16457	16417
Channel Z	15874	17196

5. Input Offset Measurement

DASY measurement parameters: Auto Zero Time: 3 sec; Measuring time: 3 sec

Input 10MΩ

	Average (μV)	min. Offset (μV)	max. Offset (μV)	Std. Deviation (μV)
Channel X	-0.50	-1.93	1.16	0.62
Channel Y	0.32	-1.78	2.06	0.72
Channel Z	-2.19	-4.30	-0.47	0.66

6. Input Offset Current

Nominal Input circuitry offset current on all channels: <25fA

7. Input Resistance (Typical values for information)

	Zeroing (kOhm)	Measuring (MOhm)
Channel X	200	200
Channel Y	200	200
Channel Z	200	200

8. Low Battery Alarm Voltage (Typical values for information)

Typical values	Alarm Level (VDC)
Supply (+ Vcc)	+7.9
Supply (- Vcc)	-7.6

9. Power Consumption (Typical values for information)

Typical values	Switched off (mA)	Stand by (mA)	Transmitting (mA)
Supply (+ Vcc)	+0.01	+6	+14
Supply (- Vcc)	-0.01	-8	-9



Add: No.51 Xueyuan Road, Haidian District, Beijing, 100191, China
 Tel: +86-10-62304633-2218 Fax: +86-10-62304633-2209
 E-mail: cttl@chinattl.com [Http://www.chinattl.cn](http://www.chinattl.cn)



Client **ECIT** Certificate No: **Z17-97010**

CALIBRATION CERTIFICATE



Object: EX3DV4 - SN:3754
 Calibration Procedure(s): FD-Z11-004-01
 Calibration Procedures for Dosimetric E-field Probes
 Calibration date: January 13, 2017

This calibration Certificate documents the traceability to national standards, which realize the physical units of measurements(SI). The measurements and the uncertainties with confidence probability are given on the following pages and are part of the certificate.

All calibrations have been conducted in the closed laboratory facility: environment temperature(22±3)°C and humidity<70%.

Calibration Equipment used (M&TE critical for calibration)

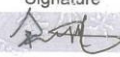
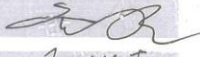
Primary Standards	ID #	Cal Date(Calibrated by, Certificate No.)	Scheduled Calibration
Power Meter NRP2	101919	27-Jun-16 (CTTL, No.J16X04777)	Jun-17
Power sensor NRP-Z91	101547	27-Jun-16 (CTTL, No.J16X04777)	Jun-17
Power sensor NRP-Z91	101548	27-Jun-16 (CTTL, No.J16X04777)	Jun-17
Reference10dBAttenuator	18N50W-10dB	13-Mar-16(CTTL,No.J16X01547)	Mar-18
Reference20dBAttenuator	18N50W-20dB	13-Mar-16(CTTL, No.J16X01548)	Mar-18
Reference Probe EX3DV4	SN 7433	26-Sep-16(SPEAG,No.EX3-7433_Sep16)	Sep-17
DAE4	SN 1331	21-Jan-16(SPEAG, No.DAE4-1331_Jan16)	Jan -17
Secondary Standards	ID #	Cal Date(Calibrated by, Certificate No.)	Scheduled Calibration
SignalGeneratorMG3700A	6201052605	27-Jun-16 (CTTL, No.J16X04776)	Jun-17
Network Analyzer E5071C	MY46110673	26-Jan-16 (CTTL, No.J16X00894)	Jan -17

	Name	Function	Signature
Calibrated by:	Yu Zongying	SAR Test Engineer	
Reviewed by:	Qi Dianyuan	SAR Project Leader	
Approved by:	Lu Bingsong	Deputy Director of the laboratory	

Issued: January 14, 2017

This calibration certificate shall not be reproduced except in full without written approval of the laboratory.



Add: No.51 Xueyuan Road, Haidian District, Beijing, 100191, China
 Tel: +86-10-62304633-2218 Fax: +86-10-62304633-2209
 E-mail: cttl@chinattl.com [Http://www.chinattl.cn](http://www.chinattl.cn)

Glossary:

- TSL tissue simulating liquid
- NORM_{x,y,z} sensitivity in free space
- ConvF sensitivity in TSL / NORM_{x,y,z}
- DCP diode compression point
- CF crest factor (1/duty_cycle) of the RF signal
- A,B,C,D modulation dependent linearization parameters
- Polarization Φ Φ rotation around probe axis
- Polarization θ θ rotation around an axis that is in the plane normal to probe axis (at measurement center), i
 $\theta=0$ is normal to probe axis

Connector Angle information used in DASY system to align probe sensor X to the robot coordinate system

Calibration is Performed According to the Following Standards:

- a) IEEE Std 1528-2013, "IEEE Recommended Practice for Determining the Peak Spatial-Averaged Specific Absorption Rate (SAR) in the Human Head from Wireless Communications Devices: Measurement Techniques", June 2013
- b) IEC 62209-1, "Procedure to measure the Specific Absorption Rate (SAR) for hand-held devices used in close proximity to the ear (frequency range of 300MHz to 3GHz)", February 2005
- c) IEC 62209-2, "Procedure to determine the Specific Absorption Rate (SAR) for wireless communication devices used in close proximity to the human body (frequency range of 30 MHz to 6 GHz)", March 2010
- d) KDB 865664, "SAR Measurement Requirements for 100 MHz to 6 GHz"

Methods Applied and Interpretation of Parameters:

- **NORM_{x,y,z}:** Assessed for E-field polarization $\theta=0$ ($f \leq 900\text{MHz}$ in TEM-cell; $f > 1800\text{MHz}$: waveguide). NORM_{x,y,z} are only intermediate values, i.e., the uncertainties of NORM_{x,y,z} does not effect the E^2 -field uncertainty inside TSL (see below ConvF).
- **NORM(f)_{x,y,z} = NORM_{x,y,z} * frequency_response** (see Frequency Response Chart). This linearization is implemented in DASY4 software versions later than 4.2. The uncertainty of the frequency response is included in the stated uncertainty of ConvF.
- **DCP_{x,y,z}:** DCP are numerical linearization parameters assessed based on the data of power sweep (no uncertainty required). DCP does not depend on frequency nor media.
- **PAR:** PAR is the Peak to Average Ratio that is not calibrated but determined based on the signal characteristics.
- **A_{x,y,z}; B_{x,y,z}; C_{x,y,z}; VR_{x,y,z}:** A,B,C are numerical linearization parameters assessed based on the data of power sweep for specific modulation signal. The parameters do not depend on frequency nor media. VR is the maximum calibration range expressed in RMS voltage across the diode.
- **ConvF and Boundary Effect Parameters:** Assessed in flat phantom using E-field (or Temperature Transfer Standard for $f \leq 800\text{MHz}$) and inside waveguide using analytical field distributions based on power measurements for $f > 800\text{MHz}$. The same setups are used for assessment of the parameters applied for boundary compensation (alpha, depth) of which typical uncertainty valued are given. These parameters are used in DASY4 software to improve probe accuracy close to the boundary. The sensitivity in TSL corresponds to NORM_{x,y,z} * ConvF whereby the uncertainty corresponds to that given for ConvF. A frequency dependent ConvF is used in DASY version 4.4 and higher which allows extending the validity from $\pm 50\text{MHz}$ to $\pm 100\text{MHz}$.
- **Spherical isotropy (3D deviation from isotropy):** in a field of low gradients realized using a flat phantom exposed by a patch antenna.
- **Sensor Offset:** The sensor offset corresponds to the offset of virtual measurement center from the probe tip (on probe axis). No tolerance required.
- **Connector Angle:** The angle is assessed using the information gained by determining the NORM_x (no uncertainty required).



Add: No.51 Xueyuan Road, Haidian District, Beijing, 100191, China
Tel: +86-10-62304633-2218 Fax: +86-10-62304633-2209
E-mail: ctl@chinattl.com [Http://www.chinattl.cn](http://www.chinattl.cn)

Probe EX3DV4

SN: 3754

Calibrated: January 13, 2017

Calibrated for DASY/EASY Systems

(Note: non-compatible with DASY2 system!)



In Collaboration with
TTL speag
 CALIBRATION LABORATORY
 Add: No.51 Xueyuan Road, Haidian District, Beijing, 100191, China
 Tel: +86-10-62304633-2218 Fax: +86-10-62304633-2209
 E-mail: cttl@chinattl.com [Http://www.chinattl.cn](http://www.chinattl.cn)

DASY/EASY – Parameters of Probe: EX3DV4 – SN: 3754

Basic Calibration Parameters

	Sensor X	Sensor Y	Sensor Z	Unc (k=2)
Norm($\mu\text{V}/(\text{V}/\text{m})^2$) ^A	0.48	0.41	0.59	$\pm 10.8\%$
DCP(mV) ^B	102.4	100.9	102.7	

Modulation Calibration Parameters

UID	Communication System Name		A dB	B dB $\sqrt{\mu\text{V}}$	C	D dB	VR mV	Unc ^E (k=2)
0	CW	X	0.0	0.0	1.0	0.00	198.9	$\pm 2.0\%$
		Y	0.0	0.0	1.0		175.6	
		Z	0.0	0.0	1.0		221.1	

The reported uncertainty of measurement is stated as the standard uncertainty of Measurement multiplied by the coverage factor k=2, which for a normal distribution corresponds to a coverage probability of approximately 95%.

^A The uncertainties of Norm X, Y, Z do not affect the E²-field uncertainty inside TSL (see Page 5 and Page 6).

^B Numerical linearization parameter: uncertainty not required.

^E Uncertainty is determined using the max. deviation from linear response applying rectangular distribution and is expressed for the square of the field value.