



# TEST REPORT

**No. I17D00059-EMC**

*For*

**Client : MobiWire SAS**

**Production: 3G Smart Phone**

**Model Name : MobiWire Kosumi**

**Hardware Version: V01**

**SoftwareVersion: V01**

**FCC ID: QPN-KOSUMI**

**Issued date: 2017-04-17**

**Note:**

The test results in this test report relate only to the devices specified in this report. This report shall not be reproduced except in full without the written approval of ECIT Shanghai.

**Test Laboratory:**

ECIT Shanghai, East China Institute of Telecommunications

Add: 7F, G Area, No.668, Beijing East Road, Huangpu District, Shanghai, P. R. China

Tel: (+86)-021-63843300, E-Mail: [welcome@ecit.org.cn](mailto:welcome@ecit.org.cn)

### Revision Version

Report Number	Revision	Date	Memo
I17D00059-EMC	00	2017-04-17	Initial creation of test report

## CONTENTS

<b>1. TEST LABORATORY .....</b>	<b>5</b>
<b>1.1. TESTING LOCATION .....</b>	<b>5</b>
<b>1.2. TESTING ENVIRONMENT .....</b>	<b>5</b>
<b>1.3. PROJECT DATA.....</b>	<b>5</b>
<b>1.4. SIGNATURE .....</b>	<b>5</b>
<b>2. CLIENT INFORMATION .....</b>	<b>6</b>
<b>2.1. APPLICANT INFORMATION .....</b>	<b>6</b>
<b>2.2. MANUFACTURER INFORMATION .....</b>	<b>6</b>
<b>3. EQUIPMENT UNDER TEST (EUT) AND ANCILLARY EQUIPMENT (AE) .....</b>	<b>7</b>
<b>3.1. ABOUT EUT .....</b>	<b>7</b>
<b>3.2. INTERNAL IDENTIFICATION OF EUT USED DURING THE TEST.....</b>	<b>7</b>
<b>3.3. INTERNAL IDENTIFICATION OF AE USED DURING THE TEST .....</b>	<b>7</b>
<b>4. REFERENCE DOCUMENTS.....</b>	<b>8</b>
<b>4.3. REFERENCE DOCUMENTS FOR TESTING .....</b>	<b>8</b>
<b>5. TEST RESULTS.....</b>	<b>9</b>
<b>5.3. SUMMARY OF TEST RESULTS.....</b>	<b>9</b>
<b>5.4. STATEMENTS.....</b>	<b>9</b>
<b>6. TEST EQUIPMENTS UTILIZED.....</b>	<b>10</b>
<b>6.1 RADIATED EMISSION EQUIPMENTS LIST .....</b>	<b>10</b>
<b>6.1 CE EQUIPMENTS LIST.....</b>	<b>10</b>
<b>7. SYSTEM CONFIGURATION DURING TEST .....</b>	<b>11</b>
<b>7.1 TEST MODE.....</b>	<b>11</b>
<b>7.2 CONNECTION DIAGRAM OF TEST SYSTEM.....</b>	<b>11</b>
<b>8. MEASUREMENT RESULTS .....</b>	<b>12</b>
<b>8.1 RADIATED EMISSION 30MHZ-12.75GHZ .....</b>	<b>12</b>

**8.2 CONDUCTED EMISSION..... 15**

## 1. Test Laboratory

### 1.1. Testing Location

Company Name: ECIT Shanghai, East China Institute of Telecommunications  
Address: 7F, G Area, No. 668, Beijing East Road, Huangpu District, Shanghai,  
P. R. China  
Postal Code: 200001  
Telephone: 86-21-63843300  
Fax: 86-21-63843301  
FCC registration No: 489729

### 1.2. Testing Environment

Normal Temperature: 15-35°C  
Relative Humidity: 30-60%

### 1.3. Project data

Project Leader: Yu Anlu  
Testing Start Date: 04-05,2017  
Testing End Date: 04-15, 2017

### 1.4. Signature

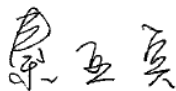

Qin Yabin

(Prepared this test report)



You Jinjun

(Reviewed this test report)

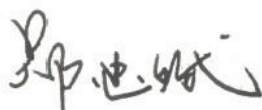

Zheng Zhongbin

Director of the laboratory

(Approved this test report)

## 2. Client Information

### 2.1. Applicant Information

Company Name: Mobewire SAS  
Address /Post: 79 AVENUE FRANCOIS ARAGO 92017 NANTERRE CEDEX  
France.  
Tel: +33 178 14 09 58  
City: /  
Country: /

### 2.2. Manufacturer Information

Company Name: MOBIWIRE MOBILES (NINGBO) CO.,LTD  
Address /Post: No.999,Dacheng East Road,Fenghua City,Zhejiang  
Tel: 0574 88916345  
City: /  
Country: /

### 3. Equipment under Test (EUT) and Ancillary Equipment (AE)

#### 3.1. About EUT

EUT Description	3G SmartPhone
Model name	MobiWire Kosumi
Serial Number or IMEI	351780080668553
HW Version	V01
SW Version	V01
Additional Communication Function	BT 2.1/EDR/3.0/4.0/BLE ;WIFI b/g/n-20;FM;

#### 3.2. Internal Identification of EUT used during the test

EUT ID*	SN or IMEI	HW Version	SW Version	Date of receipt
N06	351780080668553	V01	V01	2017-4-5

\*EUT ID: is used to identify the test sample in the lab internally.

#### 3.3. Internal Identification of AE used during the test

AE ID*	Description	Model	SN
C201	Adapter	RD0501000-USBA-18MG	NA
U105	USB Cable	NA	NA
A102	Earphone	NA	NA
B06	Battery	NA	VK1216008380
AE4	Data Cable	NA	NA
AE5	Desktop PC	M4390	BA00868638
AE6	Notebook PC	DELL Latitude E6510	/
AE7	LAN Cable	NA	NA
AE8	VGA Cable	NA	NA
AE9	RS232 Cable	NA	NA
AE10	Keyboard	KB212	/
AE11	Mouse	MS111	/

\*AE ID: is used to identify the test sample in the lab internally.

## 4. Reference Documents

### 4.3. Reference Documents for testing

The following documents listed in this section are referred for testing.

Reference	Title	Version
FCC Part 15, Subpart B	Radio frequency devices	10-1-10 Edition
ANSI C63.4	Method of Measurement of Radio-Noise Emissions from Low-Voltage Electrical and Electronic Equipment in the Range of 9 kHz to 40 GHz	2014



## 5. Test Results

### 5.3. Summary of Test Results

Items	Test List	Clause in FCC rules	Verdict
1	Radiated Emission	15.109(a)	Pass
2	Conducted Emission	15.107(a)	Pass

### 5.4. Statements

The 3G SmartPhone, manufactured by MOBIWIRE MOBILES (NINGBO) CO.,LTD is a new product for testing. ECIT performed test cases which identified with Pass/Fail/Inc result in section 5.1.

ECIT has verified that the compliance of the tested device specified in section 3 of this test report is successfully evaluated according to the procedure and test methods as defined in type certification requirement listed in section 4 of this test report.

## 6. Test Equipments Utilized

### 6.1 Radiated Emission Equipments list

No.	Name	Type	Series Number	Producer	Cal. Date	Cal. interval
1	Universal Radio Communication	CMU200	123126	R&S	2016-05-12	1 Year
2	Test Receiver	ESU40	100307	R&S	2016-05-12	1 Year
3	Trilog Antenna	VULB9163	VULB9163-515	Schwarzbeck	2014-11-05	3 Year
4	Double Ridged Guide	ETS-3117	00135885	ETS	2014-05-06	3 Year
5	EMI Test Software	EMC32 V9.15	NA	R&S	NA	NA

### 6.1 CE Equipments list

No.	Name	Type	Series Number	Producer	Cal. Date	Cal. interval
1	Universal Radio	CMU200	123123	R&S	2016-05-12	1 Year
2	Test Receiver	ESCI	101235	R&S	2016-05-12	1 Year
3	2-Line V-Network	ENV216	101380	R&S	2016-05-12	1 Year
4	EMI Test Software	EMC32 V9.15	NA	R&S	NA	NA

## 7. System Configuration during Test

### 7.1 Test Mode

Test Item	Function Type
AC Conducted Emission	Mode 1: USB cable (Data Link with PC) <Figure 1> Mode 2: Adapter charging <Figure 2>
Radiated Emission	Mode 1: USB cable (Data Link with PC) <Figure 1> Mode 2: Adapter charging <Figure 2>
Remark: 1. All test modes are performed, only the worst cases test data are recorded in this report. 2. Data Link with PC means data application transferred mode between EUT and PC.	

### 7.2 Connection Diagram of Test System

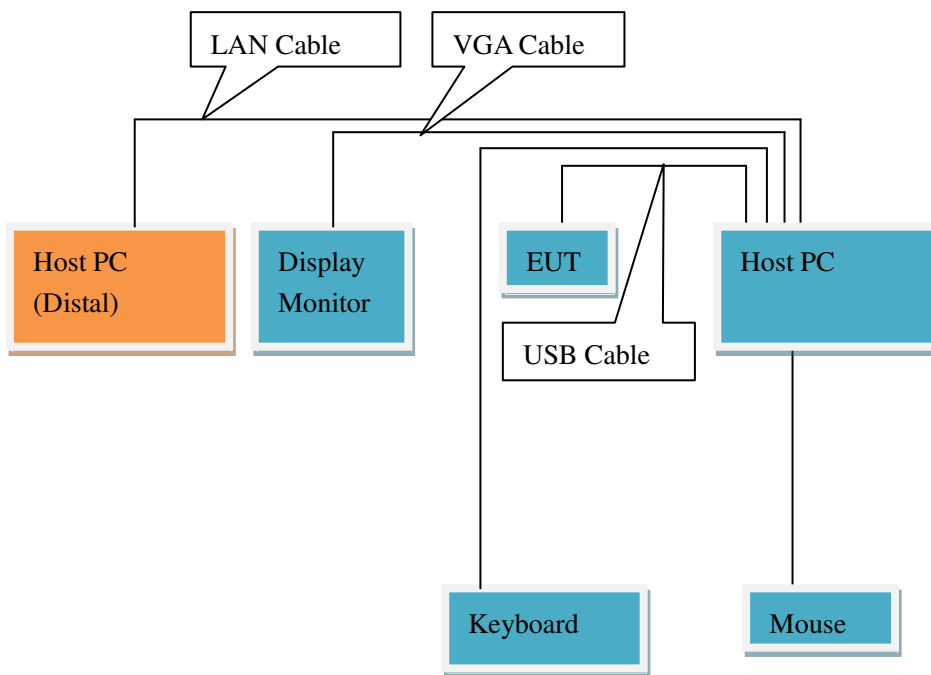

<Figure 1>



<Figure 2>

## 8. Measurement Results

Only the worst test result was shown in this report.

### 8.1 Radiated Emission 30MHz-12.75GHz

#### Method of Measurement

For 30-1000MHz, the EUT was placed on the top of a rotating 0.8-m table above the ground at a semi-anechoic chamber. The distance between the EUT and the received antenna was 3 meters. The table was rotated 360 degree and the received antenna mounted on a variable-height antenna tower was varied from 1m to 4m to find the maximum value of the field strength. Both horizontal and vertical polarizations of the antenna were set during the measurement .Tested in accordance with the procedures of ANSI C63.4-2014, section 8.3.

For 1000-12750MHz,The maximal emission value was acquired by adjusting the antenna height, The table was rotated 360 degree to determine the maximum value of the field strength. Both horizontal and vertical polarizations of the antenna were set during the measurement.

#### Limits for Radiated Emission at a measuring distance of 3m

Frequency Range (MHz)	Quasi-Peak (dBuV/m)
30-88	40
88-216	43.5
216-960	46
Above 960	54

Frequency Range (MHz)	Peak (dBuV/m)	Average (dBuV/m)
Above 1000	74	54

#### Test conditions

Frequency Range (MHz)	RBW/VBW	Sweep Time (s)
30-1000	120KHz/300KHz	Auto
1000-12750	1MHz/3MHz	Auto

#### Uncertainty Measurement

The measurement uncertainty is 5.82dB (k=2).

## Test Results

Mode 2: Adapter charging

Frequency Range: 30MHz – 1GHz

RE 30MHz-1GHz

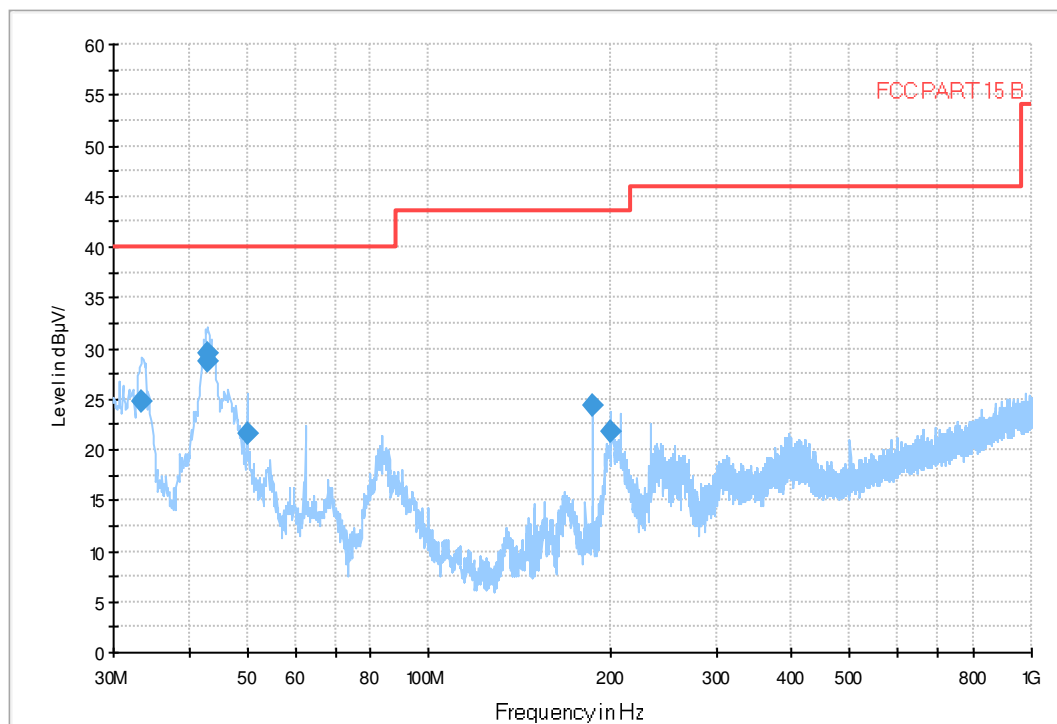

Frequency (MHz)	QuasiPeak (dBµV/m)	Limit (dBµV/m)	Margin (dB)	Meas. Time (ms)	Bandwidth (kHz)	Height (cm)	Pol	Azimuth h (deg)	Corr. (dB)
33.492000	24.8	40.00	15.2	1000.0	120.000	100.0	V	135.0	-26.5
42.898000	29.5	40.00	10.5	1000.0	120.000	100.0	V	47.0	-24.2
42.916000	28.6	40.00	11.4	1000.0	120.000	100.0	V	270.0	-24.2
49.982000	21.5	40.00	18.5	1000.0	120.000	100.0	V	315.0	-23.7
187.528000	24.4	43.50	19.1	1000.0	120.000	100.0	V	176.0	-26.1
200.044000	21.8	43.50	21.7	1000.0	120.000	100.0	V	207.0	-24.8

**Note:**

1. Emission level(QP)=Raw value by receiver + Corr(Antenna factor + cable loss - preamplifier gain)
2. The raw value is used to calculate by software which is not shown in the sheet.
3. Margin=limit value – emission level.

Mode 2: Adapter charging

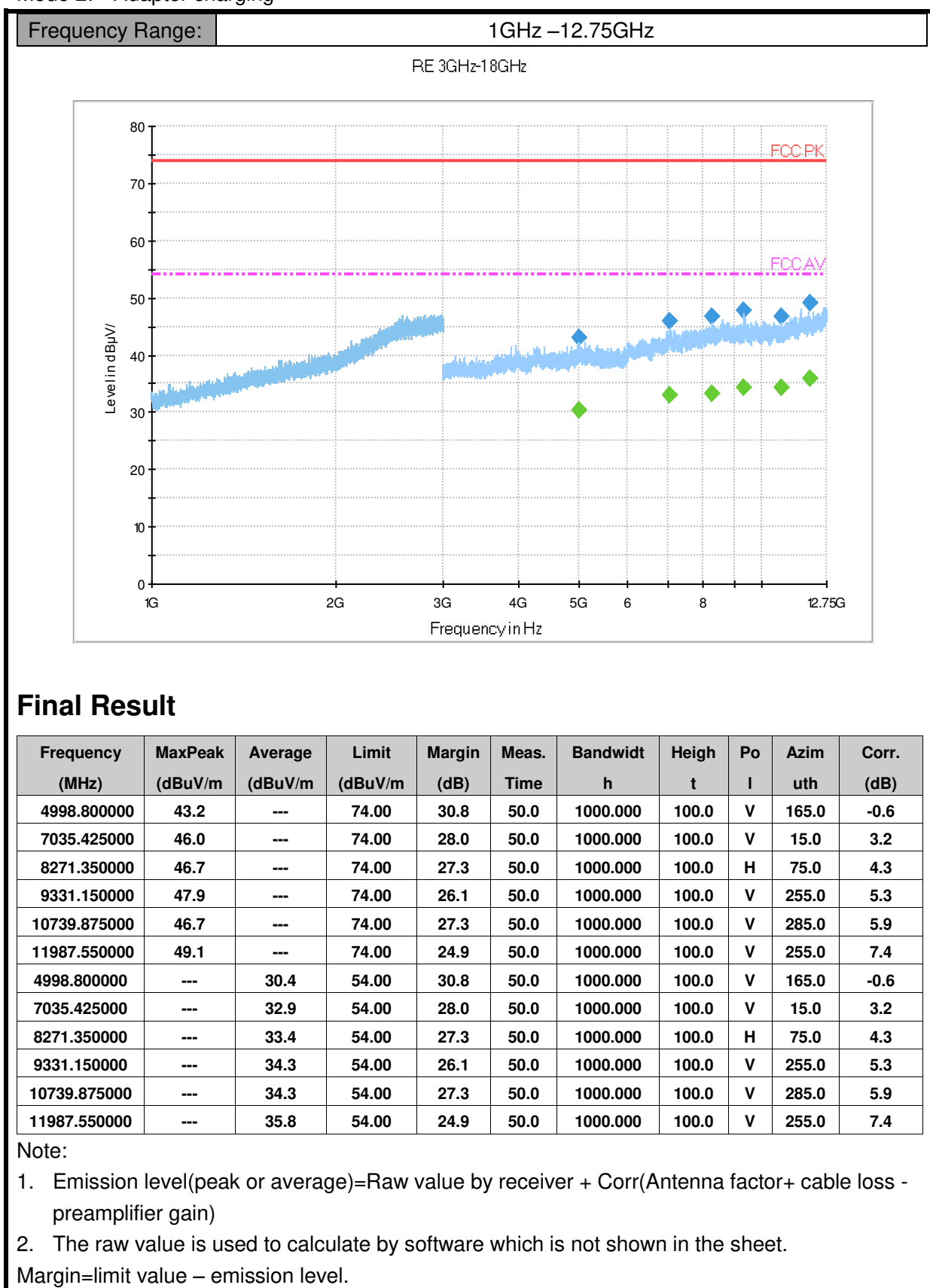

## 8.2 Conducted Emission

### Method of Measurement

For equipment that is designed to be connected to the public utility (AC) power line, the radio frequency voltage that is conducted back onto the AC power line on any frequency or frequencies with the band 150 kHz to 30MHz shall not exceed the limits. Both lines of the power mains connected to the EUT were checked for maximum conducted interference. Tested in accordance with the procedures of ANSI C63.4-2014, section 7.3

### Limit of Conducted Emission

Frequency Range (MHz)	Conducted Limit (dBuV)	
	Quasi-peak	Average
0.15-0.5	66 to 56*	56 to 46*
0.5-5	56	46
5-30	60	50

\*Decreases with the logarithm of the frequency

### Test Condition in Charging Mode

Voltage (V)	Frequency (Hz)	RBW	Sweep Time (s)
120	60	9 KHz	Auto

### Uncertainty Measurement

The measurement uncertainty is 3.47dB (k=2).

### Test Results

Mode 1: USB cable (Data Link with PC)

Frequency Range:

150kHz – 30MHz

CISPR N&L1 Voltage 150k to 30MHz-Class B

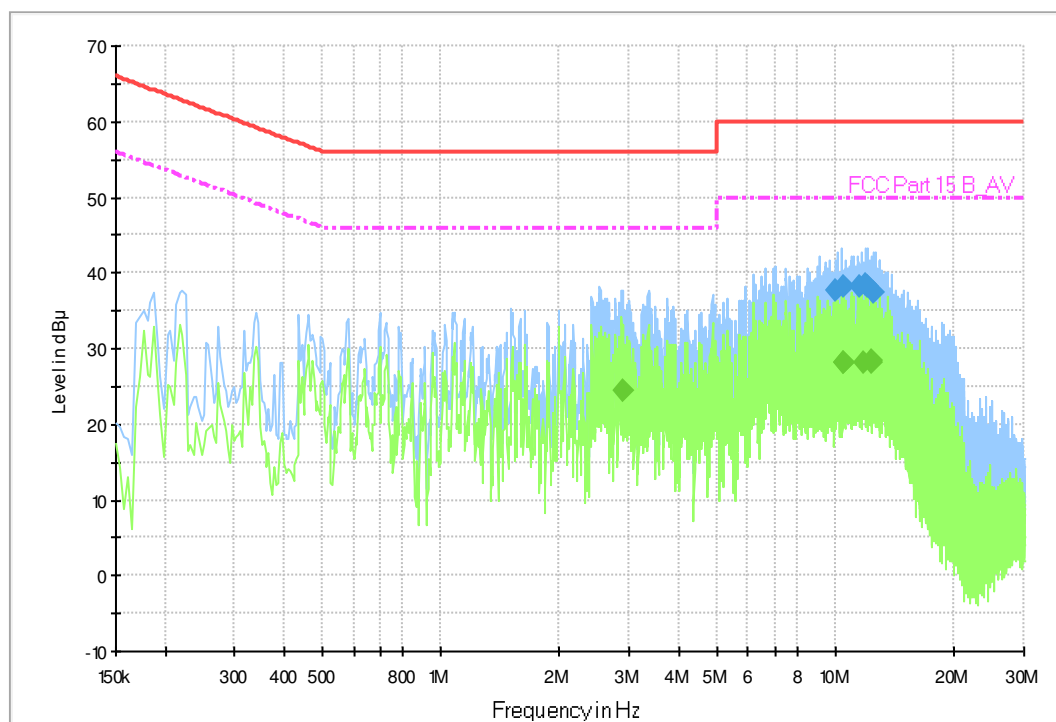

Frequency (MHz)	QuasiPeak (dB µV)	Average (dB µV)	Limit (dB µV)	Margin (dB)	Meas. Time	Bandwidth (kHz)	Line	Filter	Corr. (dB)
10.045094	37.7	---	60.0	22.3	1000.0	9.000	L1	ON	9.9
10.439625	38.3	---	60.0	21.7	1000.0	9.000	L1	ON	9.9
11.552250	38.1	---	60.0	21.9	1000.0	9.000	L1	ON	9.9
11.911050	38.4	---	60.0	21.6	1000.0	9.000	L1	ON	9.9
11.981912	38.1	---	60.0	21.9	1000.0	9.000	L1	ON	9.9
12.439781	37.3	---	60.0	22.7	1000.0	9.000	L1	ON	9.9
2.891812	---	24.6	46.0	21.4	1000.0	9.000	L1	ON	9.7
10.463625	---	28.1	50.0	21.9	1000.0	9.000	L1	ON	9.9
10.507831	---	28.1	50.0	21.9	1000.0	9.000	L1	ON	9.9
11.712250	---	28.2	50.0	21.8	1000.0	9.000	L1	ON	9.9
12.364650	---	28.3	50.0	21.7	1000.0	9.000	L1	ON	9.9
12.392319	---	28.3	50.0	21.7	1000.0	9.000	L1	ON	9.9

Note:

1. Emission level(quasi-peak or Average peak)=Raw value by receiver + Corr(Insertion loss+ cable loss)
2. The raw value is used to calculate by software which is not shown in the sheet.
3. Margin=limit value – emission level.
4. L1 and N line is all have been tested, the result of them is synthesized in the above data diagram.

\*\*\*\*\*End the Report\*\*\*\*\*