

**Industrial Internet Innovation Center (Shanghai) Co.,Ltd.**

**FCC 5GWLAN TEST REPORT**

<b>PRODUCT</b>	4G Smart Phone
<b>BRAND</b>	MobiWire,MobiWire,Vodafone,Orange
<b>MODEL</b>	H5028,Smart Green,Vodafone Lite,Orange Neva sparkle
<b>APPLICANT</b>	MobiWire SAS
<b>FCC ID</b>	QPN-H5028
<b>ISSUE DATE</b>	November 7, 2022
<b>STANDARD(S)</b>	FCC Part15

**Prepared by: Tao Lingyan**

**Reviewed by: Yang Fan**

**Approved by: Zhang Min**

**Signature**

**Signature**

**Signature**



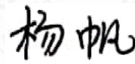



**CAUTION:**

*This report shall not be reproduced except in full without the written permission of the test laboratory and shall not be quoted out of context.*

## CONTENTS

<b>1. SUMMARY OF TEST REPORT .....</b>	<b>3</b>
1.1 TEST STANDARD(S) .....	3
1.2 REFERENCE DOCUMENTS.....	3
1.3 SUMMARY OF TEST RESULTS.....	3
1.4 DATA PROVIDED BY APPLICANT.....	4
<b>2. GENERAL INFORMATION OF THE LABORATORY .....</b>	<b>5</b>
2.1 TESTING LABORATORY .....	5
2.2 LABORATORY ENVIRONMENTAL REQUIREMENTS.....	5
2.3 PROJECT INFORMATION .....	5
<b>3. GENERAL INFORMATION OF THE CUSTOMER.....</b>	<b>6</b>
3.1 APPLICANT .....	6
3.2 MANUFACTURER .....	6
<b>4. GENERAL INFORMATION OF THE PRODUCT.....</b>	<b>7</b>
4.1 PRODUCT DESCRIPTION FOR EQUIPMENT UNDER TEST (EUT).....	7
4.2 INTERNAL IDENTIFICATION OF AE USED DURING THE TEST.....	7
4.3 ADDITIONAL INFORMATION .....	7
<b>5. TEST CONFIGURATION INFORMATION .....</b>	<b>8</b>
5.1 LABORATORY ENVIRONMENTAL CONDITIONS.....	8
5.2 TEST EQUIPMENTS UTILIZED.....	8
5.3 MEASUREMENT UNCERTAINTY .....	10
<b>6. MEASUREMENT RESULTS .....</b>	<b>11</b>
6.1 MAXIMUM OUTPUT POWER-CONDUCTED.....	11
6.2 PEAK POWER SPECTRAL DENSITY .....	17
6.3 OCCUPIED 26dB BANDWIDTH(CONDUCTED) .....	23
6.4 99% OCCUPIED BANDWIDTH(CONDUCTED).....	28
6.5 BAND EDGES COMPLIANCE.....	33
6.6 TRANSMITTER SPURIOUS EMISSION.....	40
6.7 FREQUENCY STABILITY .....	49
6.8 AC POWERLINE CONDUCTED EMISSION .....	49
<b>ANNEX A: REVISED HISTORY.....</b>	<b>52</b>
<b>ANNEX B: ACCREDITATION CERTIFICATE.....</b>	<b>53</b>

## 1. Summary of Test Report

### 1.1 Test Standard(s)

No.	Test Standard(s)	Title	Version
1	FCC Part15	Title 47 of the Code of Federal Regulations; Chapter I Part 15 - Radio frequency devices	2020

### 1.2 Reference Documents

No.	Reference	Title	Version
1	ANSI 63.10	Methods of Measurement of Radio-Noise Emissions from Low-Voltage Electrical and Electronic Equipment in the Range of 9 kHz to 40 GHz	2013
2	KDB 789033	Information Infrastructure (U-NII) Devices - Part 15, Subpart E	2017
3	KDB 905462	COMPLIANCE MEASUREMENT PROCEDURES FOR UNLICENSED-NATIONAL INFORMATION INFRASTRUCTURE DEVICES OPERATING IN THE 5250-5350 MHz AND 5470-5725 MHz BANDS INCORPORATING DYNAMIC FREQUENCY SELECTION	2016

### 1.3 Summary of Test Results

Measurement Items	Sub-clause of Part15C	Verdict
Maximum Output Power	15.407(a)	Pass
Power Spectral Density	15.407(a)	Pass
99% Occupied Bandwidth	15. 407(a)	Pass
Occupied 26dB Bandwidth	15. 407(a)	Pass
Band edge compliance	15.407(b)	Pass
Transmitter spurious emissions radiated	15.407(b)	Pass
Spurious emissions radiated < 30 MHz	15.209 & 15.407(b)	Pass
Spurious emissions conducted < 30 MHz	15.407(b)	Pass
Frequency Stability	15.407(g)	Pass
Transmit Power Control	15.407(h)	N/A
AC Powerline Conducted Emission	15.207	Pass

**NOTE:**

The H5028, Smart Green, Vodafone Lite, Orange Neva sparkle, manufactured by MobiWire SAS is a new product for testing.

Industrial Internet Innovation Center (Shanghai) Co., Ltd. only performed test cases which identified with Pass/Fail/Inc result in section 1.2.

Industrial Internet Innovation Center (Shanghai) Co., Ltd. has verified that the compliance of the tested

device specified in section 4 of this test report is successfully evaluated according to the procedure and test methods as defined in type certification requirement listed in section 1 of this test report.

- a. All the test data for each data were verified, but only the worst case was reported.
- b. The DC and low frequency voltages' measurement uncertainty is  $\pm 2\%$ .
- c. Activate simultaneous transmission in all possible configurations during the testing.

#### 1.4 Data Provided by Applicant

No.	Item(s)	Data
1	Antenna gain of EUT	-2 dBi

Note: The data of 1.4 is provided by the customer may affect the validity of the test results in this report, and the impact and consequences of this shall be undertaken by the customer.

## 2. General Information of The Laboratory

### 2.1 Testing Laboratory

Lab Name	Industrial Internet Innovation Center (Shanghai) Co.,Ltd.
Address	Building 4, No. 766, Jingang Road, Pudong, Shanghai, China
Telephone	021-68866880
FCC Registration No.	958356
FCC Designation No.	CN1177

### 2.2 Laboratory Environmental Requirements

Temperature	15°C~35°C
Relative Humidity	25%RH~75%RH
Atmospheric Pressure	101kPa

### 2.3 Project Information

Project Manager	Xu Yuting
Test Date	September 4,2022 to October 20, 2022

### 3. General Information of The Customer

#### 3.1 Applicant

Company	MobiWire SAS
Address	107 Boulevard de la Mission Marchand, 92400 Courbevoie, France.
Telephone	+33625028368

#### 3.2 Manufacturer

Company	MobiWire SAS
Address	107 Boulevard de la Mission Marchand, 92400 Courbevoie, France.

## 4. General Information of The Product

### 4.1 Product Description for Equipment under Test (EUT)

Product	4G Smart Phone
Model	H5028,Smart Green,Vodafone Lite,Orange Neva sparkle
Date of Receipt	September 4,2022/ September 22,2022
EUT ID*	S01aa/S06aa
SN/IMEI	S01aa:352243540003670 352243540003688 S06aa:352243540002615 352243540002623
Supported Radio Technology and Bands	GSM850/GSM900/DCS1800/PCS1900 WCDMA Band I/II/V/VIII LTE Band 1/3/7/20/28 BT5.0 BR/EDR/BLE WLAN 802.11 b/g/n WLAN 802.11 a/n BT5.0 BR/EDR/BLE GPS/GLONASS/Gallileo FM
Hardware Version	V01A
Software Version	Mobiwire_H5028_V01
FCC ID	QPN-H5028
NOTE: EUT ID is the internal identification code of the laboratory.	

### 4.2 Internal Identification of AE used during the test

AE ID*	Description	Model	SN/Remark
AE1	RF Cable	N/A	N/A

### 4.3 Additional Information

WLAN Frequency	UNII 1: 5150MHz-5250MHz UNII 2A: 5250MHz-5350MHz UNII 2C: 5470MHz-5725MHz
Occupied Channel Bandwidth	20 MHz: 802.11 a/n
WLAN type of modulation	OFDM

## 5. Test Configuration Information

### 5.1 Laboratory Environmental Conditions

Relative Humidity	Min. = 45 %, Max. = 55 %		
Atmospheric Pressure	101kPa		
Temperature	Normal	Minimum	Maximum
	25°C	-10°C	55°C
Working Voltage of EUT	Normal	Minimum	Maximum
	3.8V	3.6V	4.2V

### 5.2 Test Equipments Utilized

#### 5.2.1 Conducted Test System

No.	Name	Model	S/N	Manufacturer	Cal. Date	Cal. Interval
1	Programmable Power Supply	Keithley 2303	4039070	Starpoint	May 10, 2021	1.5 Years
2	Vector Signal Generator	SMBV100A	257904	R&S	February 21, 2022	1 Year
3	Temperature box	B-TF-107C	BTF107C-201804107	Boyi	May 10, 2021	1.5 Years
4	Spectrum Analyzer	FSQ40	200063	R&S	November 02, 2021	1 Year
5	USB Wideband Power Sensor	U2021XA	MY56410009	Keysight	February 21, 2022	1 Year
6	Simultaneous Sampling DQA	U2531A	TW56183514	Agilent	March 02, 2022	1 Year
7	Vector Signal Generator	SMU200A	104684	R&S	May 10, 2021	1.5 Years
8	Wireless communication comprehensive tester	CMW270	100919	R&S	May 10, 2021	1.5 Years
9	Eagle Test Software	Eagle V3.3	N/A	ECIT	N/A	N/A

#### 5.2.2 Radiated Emission Test System

No.	Name	Model	S/N	Manufacturer	Cal. Date	Cal. Interval
1	Universal Radio Communication Tester	CMU200	123123	R&S	2021/5/10	1.5 year
2	Universal Radio Communication Tester	CMW500	104178	R&S	2021/5/10	1.5 year



3	EMI Test Receiver	ESU40	100307	R&S	2022/2/23	1 year
4	TRILOG Broadband Antenna	VULB9163	VULB9163-515	Schwarzbeck	2022/3/11	1 year
5	Double-ridged Waveguide Antenna	ETS-3117	00135890	ETS	2022/3/9	2 years
6	Horn Antenna	3160-09	LM6321	ETS	2021/2/3	3 years
7	Horn Antenna	3160-10	LM5942	ETS	2021/2/3	3 years
8	Pre-amplifier	SCU08F1	8320024	R&S	2021/5/10	1.5 year
9	Pre-amplifier	SCU18	10155	R&S	2021/5/10	1.5 year
10	Pre-amplifier	SCU26	10025	R&S	2021/5/10	1.5 year
11	Pre-amplifier	SCU40	10020	R&S	2021/5/10	1.5 year
12	2-Line V-Network	ENV216	101380	R&S	44613	1 year
13	EMI Test Receiver	ESCI	101235	R&S	44615	1 year
14	EMI Test software	EMC32 V9.15	N/A	R&S	N/A	N/A
15	EMI Test software	EMC32 V10.35.02	N/A	R&S	N/A	N/A

### 5.2.3 Test Environment

**Shielding Room1** (6.0 meters×3.0 meters×2.7 meters) did not exceed following limits along the conducted RF performance testing:

Temperature	Min. = 15 °C, Max. = 35 °C
Relative humidity	Min. = 20 %, Max. = 75 %
Shielding effectiveness	> 100 dB
Ground system resistance	< 0.5 Ω
Temperature	Min. = 15 °C, Max. = 35 °C

**Control room** did not exceed following limits along the EMC testing:

Temperature	Min. = 15 °C, Max. = 35 °C
Relative humidity	Min. =30 %, Max. = 60 %
Shielding effectiveness	> 100 dB
Electrical insulation	> 10 kΩ
Ground system resistance	< 0.5 Ω

**Fully-anechoic chamber1** (9.8 meters×6.7 meters×6.7 meters) did not exceed following limits along the EMC testing:

Temperature	Min. = 15 °C, Max. = 35 °C
Relative humidity	Min. = 25 %, Max. = 75 %
Shielding effectiveness	> 100 dB
Electrical insulation	> 10 kΩ
Ground system resistance	< 0.5 Ω
VSWR	Between 0 and 6 dB, from 1GHz to 18GHz
Site Attenuation Deviation	Between -4 and 4 dB, 30MHz to 1GHz
Uniformity of field strength	Between 0 and 6 dB, from 80MHz to 3000 MHz

### 5.3 Measurement Uncertainty

Item(s)	Range	Confidence Level	Calculated Uncertainty
Peak Output Power-Conducted	2402MHz-2480MHz	95%	0.544dB
Peak Power Spectral Density	2402MHz-2480MHz	95%	0.544dB
6dB Bandwidth	2402MHz-2480MHz	95%	62.04Hz
Frequency Band Edges-Conducted	2390MHz-2488.5MHz	95%	0.544dB
Conducted Emission	9KHz-30MHz	95%	0.89dB
Conducted Emission	30MHz-2GHz	95%	0.90dB
Conducted Emission	2GHz-3.6GHz	95%	0.88dB
Conducted Emission	3.6GHz-8GHz	95%	0.96dB
Conducted Emission	8GHz-20GHz	95%	0.94dB
Conducted Emission	20GHz-22GHz	95%	0.88dB
Conducted Emission	22GHz-26GHz	95%	0.86dB
Transmitter Spurious Emission-Radiated	9KHz-30MHz	95%	5.66dB
Transmitter Spurious Emission-Radiated	30MHz-1000MHz	95%	4.98dB
Transmitter Spurious Emission-Radiated	1000MHz -18000MHz	95%	5.06dB
Transmitter Spurious Emission-Radiated	18000MHz -40000MHz	95%	5.20dB
AC Power line Conducted Emission	0.15MHz-30MHz	95%	3.66 dB

## 6. Measurement Results

### 6.1 Maximum Output Power-Conducted

#### 6.1.1 Measurement Limit and Method

Standard	Limit (dBm)
FCC 47 CFR Part 15.407(a)(1)(iv)	23 or 10+10 log10B

The measurement method SA-1 is made according to KDB 789033 E

1. Set span to encompass the entire emission bandwidth (EBW) (or, alternatively, the entire 99% occupied bandwidth) of the signal.
2. Set RBW=1MHz
3. Set VBW  $\geq$  3MHz
4. Number of points in sweep  $\geq 2 \times \text{span} / \text{RBW}$ . (This ensures that bin-to-bin spacing is  $\leq \text{RBW}/2$ , so that narrowband signals are not lost between frequency bins.)
5. Sweep time = auto.
6. Detector = power averaging (rms), if available. Otherwise, use sample detector mode.
7. If transmit duty cycle < 98%, use a video trigger with the trigger level set to enable triggering only on full power pulses. Transmitter must operate at maximum power control level for the entire duration of every sweep. If the EUT transmits continuously (i.e., with no off intervals) or at duty cycle  $\geq 98\%$ , and if each transmission is entirely at the maximum power control level, then the trigger shall be set to “free run.”
8. Trace average at least 100 traces in power averaging (rms) mode.
9. Compute power by integrating the spectrum across the EBW (or, alternatively, the entire 99% occupied bandwidth) of the signal using the instrument’s band power measurement function with band limits set equal to the EBW (or occupied bandwidth) band edges. If the instrument does not have a band power function, sum the spectrum levels (in power units) at 1 MHz intervals extending across the EBW (or, alternatively, the entire 99% occupied bandwidth) of the spectrum.

## 6.1.2 Test setup

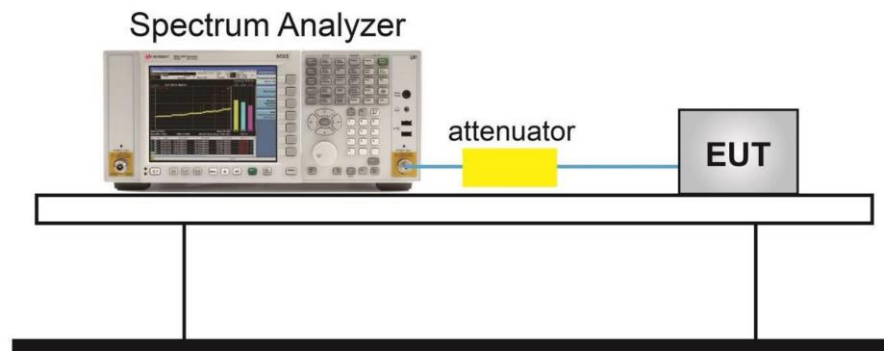

## 6.1.3 Measurement Results

## U-NII-1

Mode	Channel	Conducted (dBm)	E.I.R.P (dBm)
802.11a	5180	9.50	7.50
	5200	8.46	6.46
	5240	7.95	5.95
802.11n HT20	5180	7.56	5.56
	5200	7.09	5.09
	5240	6.85	4.85

## U-NII-2a

Mode	Channel	Conducted (dBm)	E.I.R.P (dBm)
802.11a	5260	7.23	5.23
	5280	7.61	5.61
	5320	7.02	5.02
802.11n HT20	5260	6.27	4.27
	5280	6.01	4.01
	5320	5.82	3.82

## U-NII-2c

Mode	Channel	Conducted (dBm)	E.I.R.P (dBm)
802.11a	5500	7.36	5.36
	5680	6.91	4.91

	5700	7.25	5.25
802.11n HT20	5500	5.89	3.89
	5680	6.47	4.47
	5700	6.79	4.79

## TEST PLOTS:

## U-NII-1

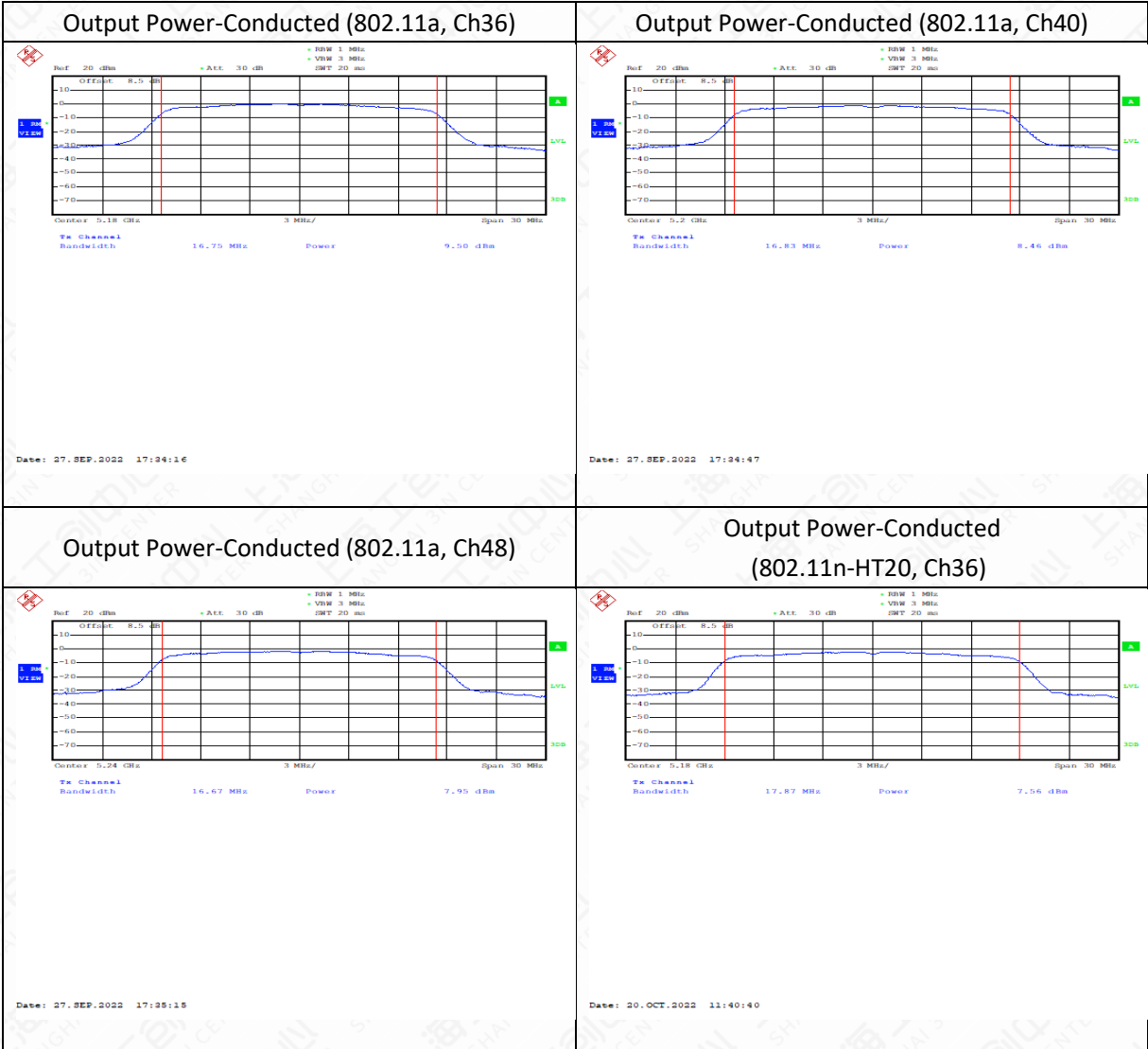

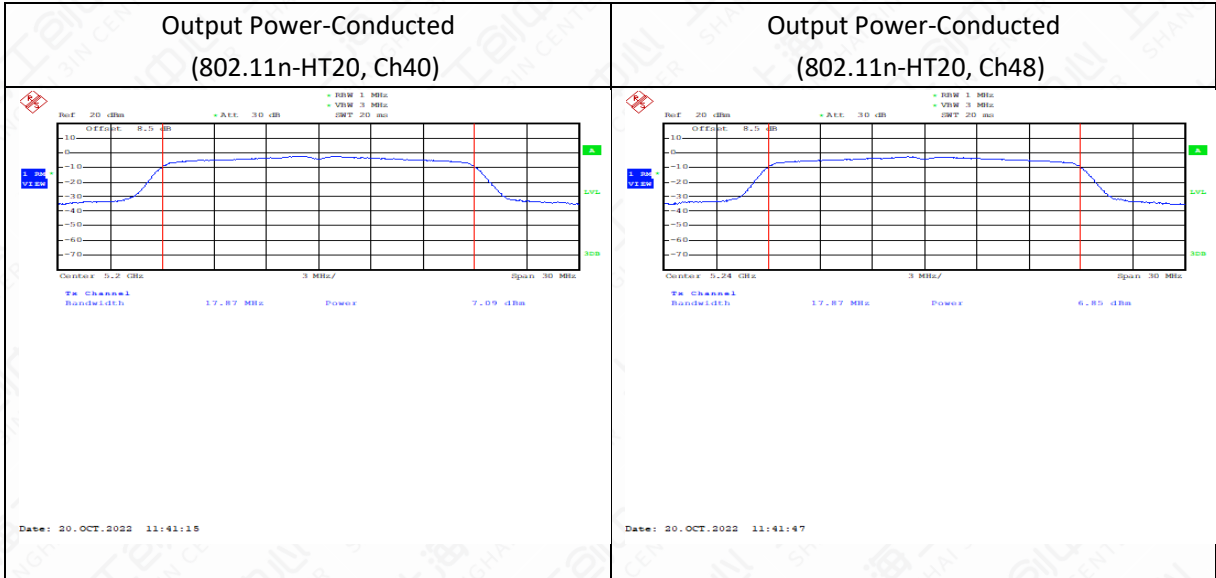

## U-NII-2a

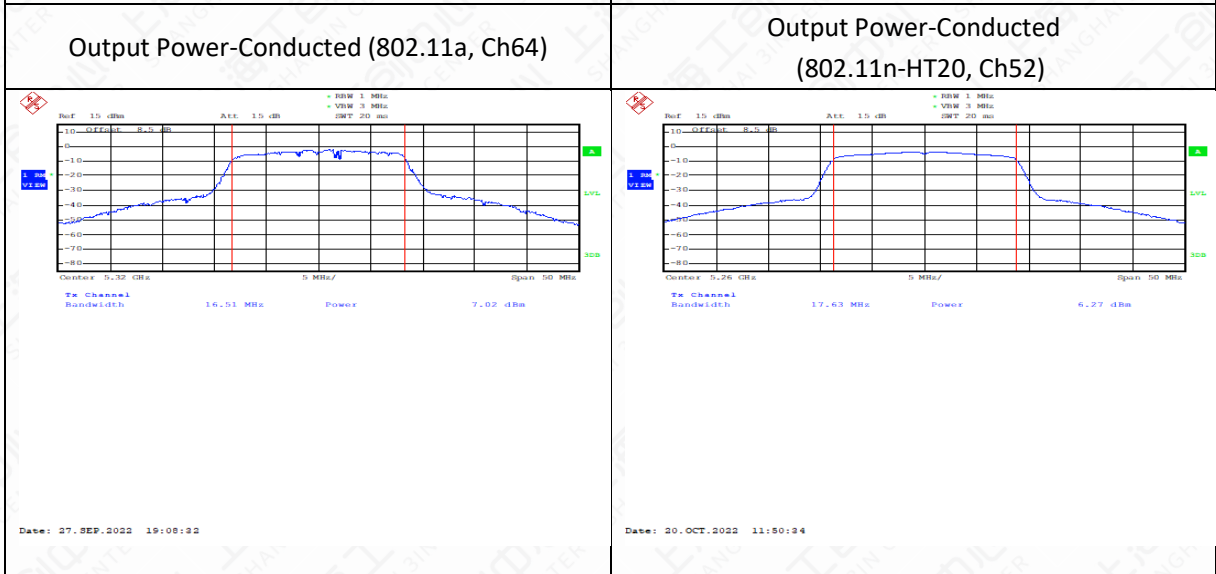
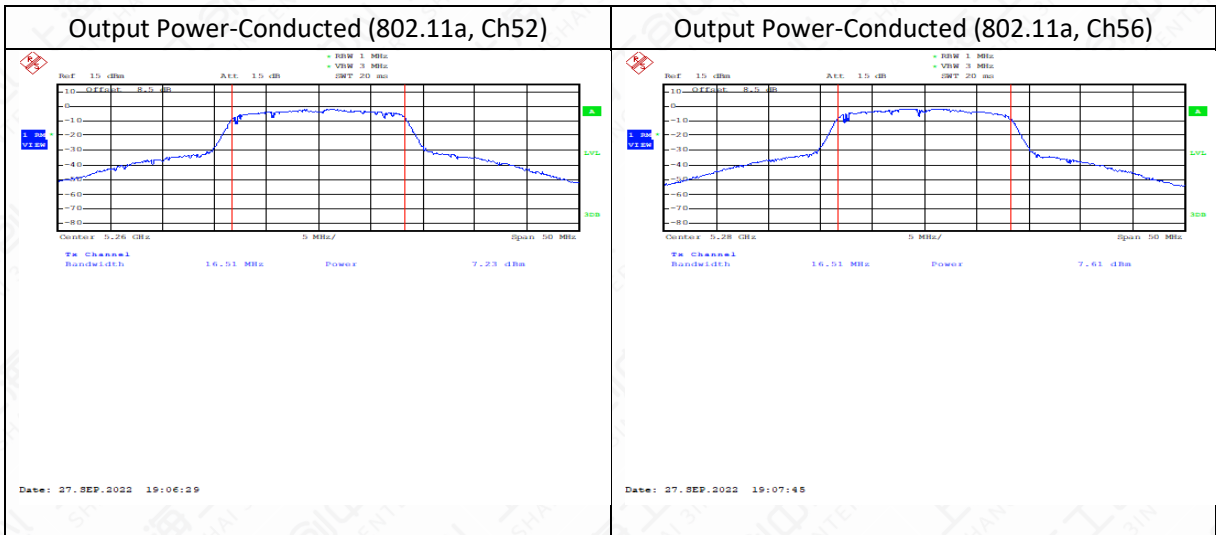

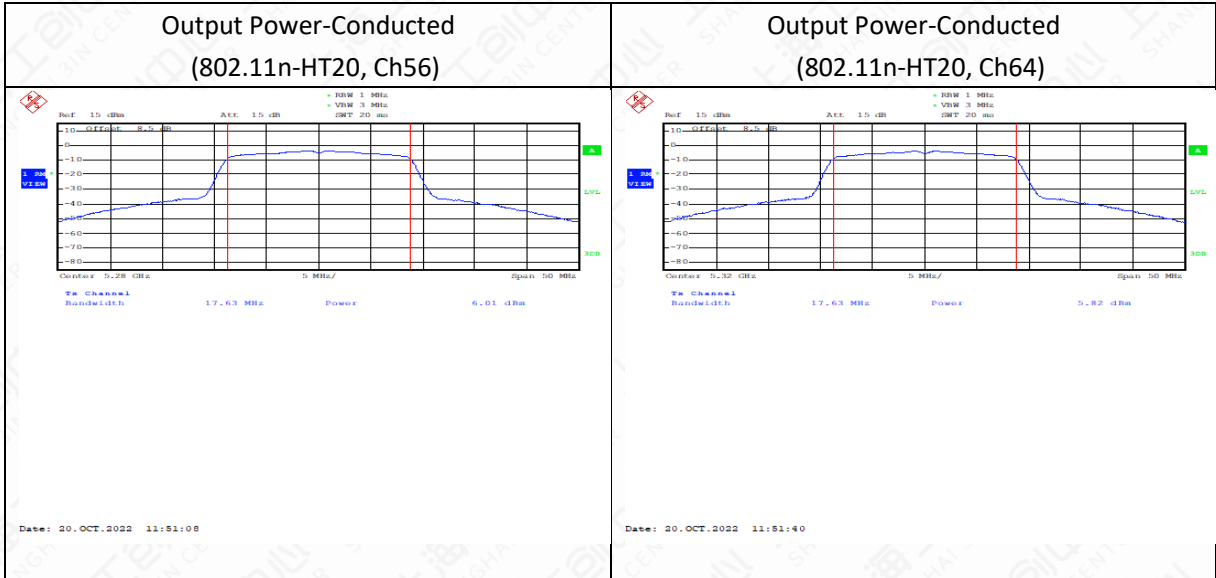

U-NII-2c

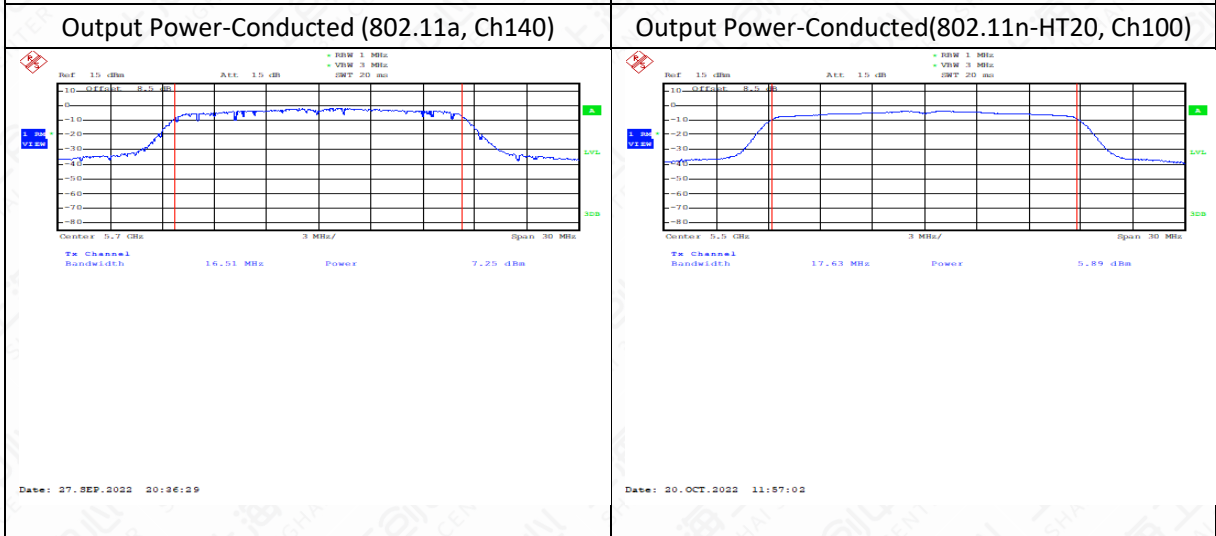
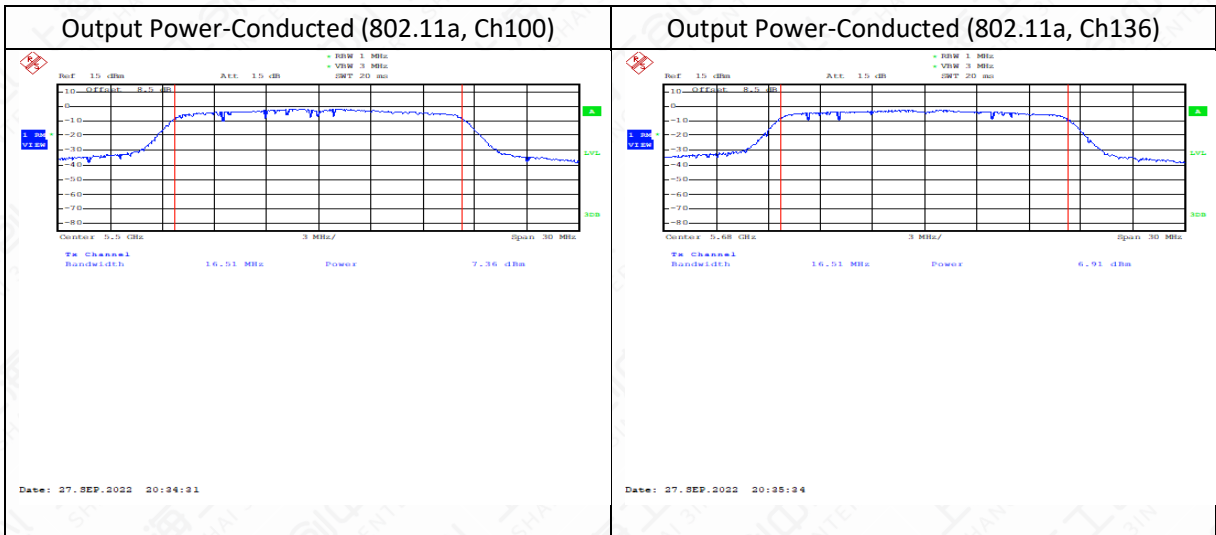

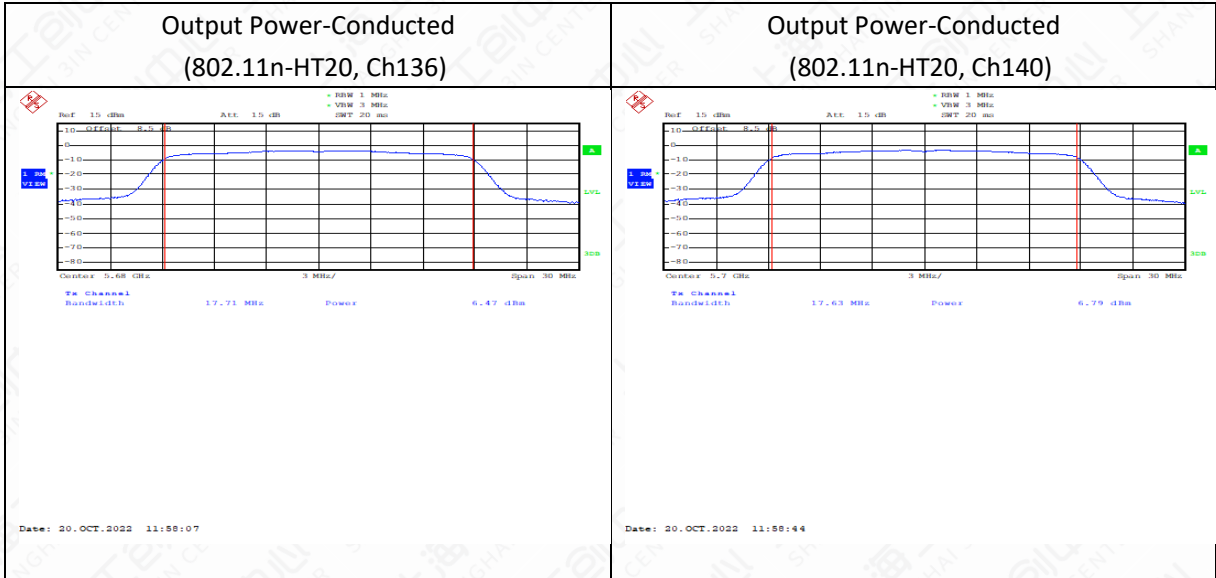



## 6.2 Peak Power Spectral Density

### 6.2.1 Measurement Limit and Method

Standard	Limit (dBm/MHz)
FCC 47 CFR Part 15.407(a)(1)(iv)	≤17

The measurement method is made according to KDB 789033 F

1. Create an average power spectrum for the EUT operating mode being tested by following the instructions in II.E.2. for measuring maximum conducted output power using a spectrum analyzer or EMI receiver: select the appropriate test method (SA-1, SA-2, SA-3, or alternatives to each) and apply it up to, but not including, the step labeled, “Compute power....” (This procedure is required even if the maximum conducted output power measurement was performed using a power meter, method PM.)
2. Use the peak search function on the instrument to find the peak of the spectrum and record its value.
3. Make the following adjustments to the peak value of the spectrum, if applicable:
  - a) If Method SA-2 or SA-2 Alternative was used, add  $10 \log (1/x)$ , where  $x$  is the duty cycle, to the peak of the spectrum.
  - b) If Method SA-3 Alternative was used and the linear mode was used in step II.E.2.g)(viii), add 1 dB to the final result to compensate for the difference between linear averaging and power averaging.
4. The result is the Maximum PSD over 1 MHz reference bandwidth.
5. For devices operating in the bands 5.15-5.25 GHz, 5.25-5.35 GHz, and 5.47-5.725 GHz, the above procedures make use of 1 MHz RBW to satisfy directly the 1 MHz reference bandwidth specified in Section 15.407(a)(5). For devices operating in the band 5.725-5.85 GHz, the rules specify a measurement bandwidth of 500 kHz. Many spectrum analyzers do not have 500 kHz RBW, thus a narrower RBW may need to be used. The rules permit the use of a RBWs less than 1 MHz, or 500 kHz, “provided that the measured power is integrated over the full reference bandwidth” to show the total power over the specified measurement bandwidth (i.e., 1 MHz, or 500 kHz). If measurements are performed using a reduced resolution bandwidth (< 1 MHz, or < 500 kHz) and integrated over 1 MHz, or 500 kHz bandwidth, the following adjustments to the procedures apply:
  - a) Set  $RBW \geq 1/T$ , where  $T$  is defined in II.B.I.a).
  - b) Set  $VBW \geq 3 RBW$ .
  - c) If measurement bandwidth of Maximum PSD is specified in 500 kHz, add  $10 \log (500$

kHz/RBW) to the measured result, whereas RBW (<500 kHz) is the reduced resolution bandwidth of the spectrum analyzer set during measurement.

d) If measurement bandwidth of Maximum PSD is specified in 1 MHz, add 10 log (1MHz/RBW) to the measured result, whereas RBW (< 1 MHz) is the reduced resolution bandwidth of spectrum analyzer set during measurement.

e) Care must be taken to ensure that the measurements are performed during a period of continuous transmission or are corrected upward for duty cycle.

Note: As a practical matter, it is recommended to use reduced RBW of 100 kHz for steps 5.c) and 5.d) above, since RBW=100 KHZ is available on nearly all spectrum analyzers.

### 6.2.2 Test setup

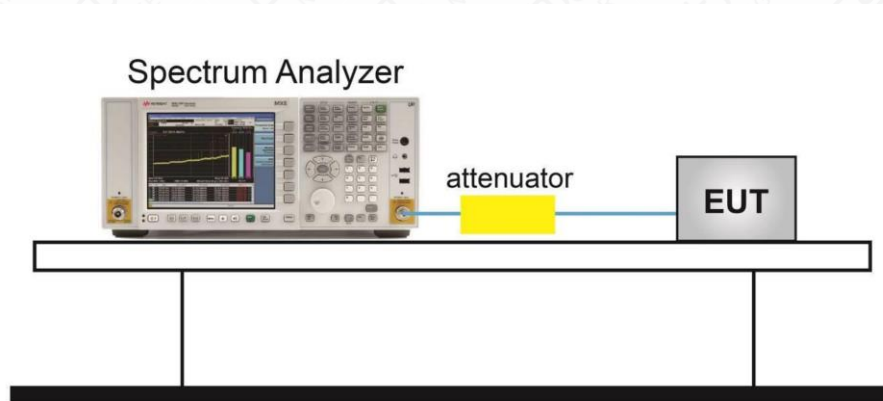

### 6.2.3 Measurement Results

#### U-NII-1

Mode	Channel	Power Spectral Density (dBm/MHz)	Conclusion
802.11a	5180	7.03	P
	5200	6.07	P
	5240	5.77	P
802.11n HT20	5180	4.71	P
	5200	4.29	P
	5240	3.95	P

#### U-NII-2a

Mode	Channel	Power Spectral Density	Conclusion
------	---------	------------------------	------------

		(dBm/MHz)	
802.11a	5260	-2.61	P
	5280	-1.77	P
	5320	-2.53	P
802.11n HT20	5260	-3.61	P
	5280	-3.56	P
	5320	-4.07	P

## U-NII-2c

Mode	Channel	Power Spectral Density (dBm/MHz)	Conclusion
802.11a	5500	-2.56	P
	5680	-2.55	P
	5700	-2.09	P
802.11n HT20	5500	-4.22	P
	5680	-3.69	P
	5700	-3.70	P

## Note:

1. Total PSD(dBm/ MHz)=  $10 * \log\{10^{(Ant\ 0\ PSD/10)} + 10^{(Ant\ 1\ PSD/10)}\}$  (dBm/MHz).

2. For the band 5.15-5.25 GHz, The Directional Gain =6.01 dBi, so the PSD Limit was calculated as below:

The PSD Limit (dBm/MHz)=[17 -(6.91 - 6)](dBm/MHz)= 16.09(dBm/MHz).

Test graphs as below:

U-NII-1

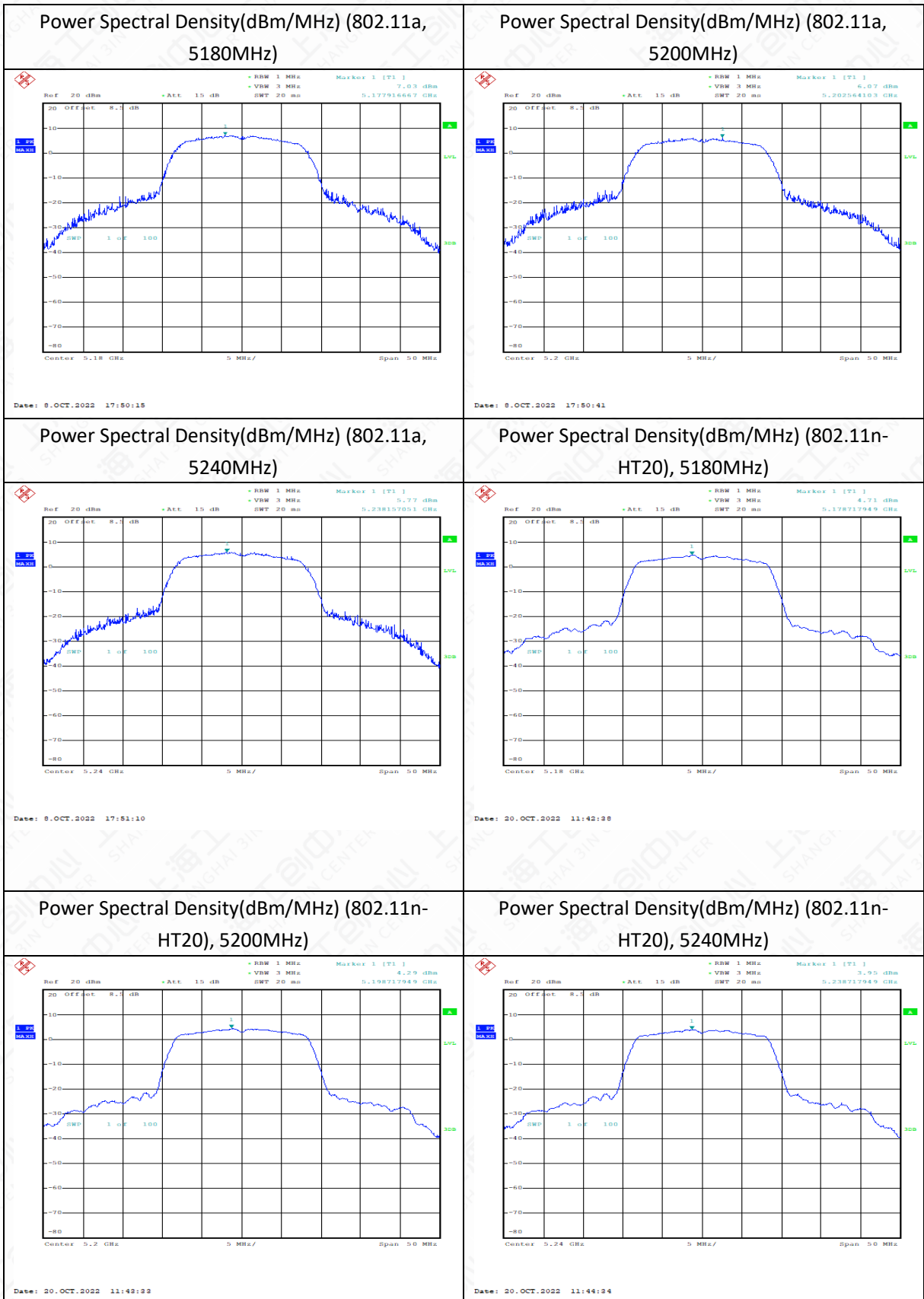

U-NII-2a

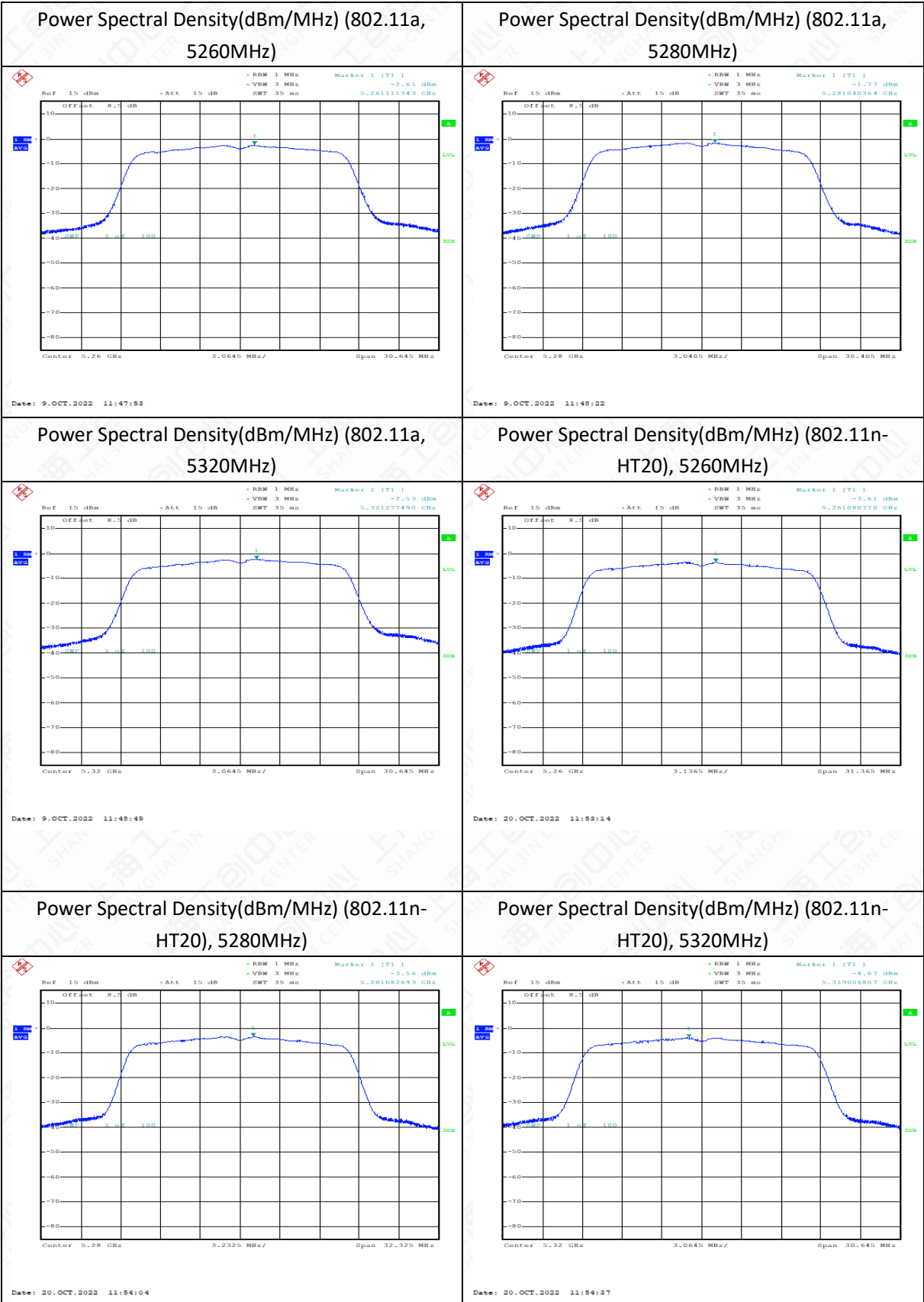

U-NII-2c

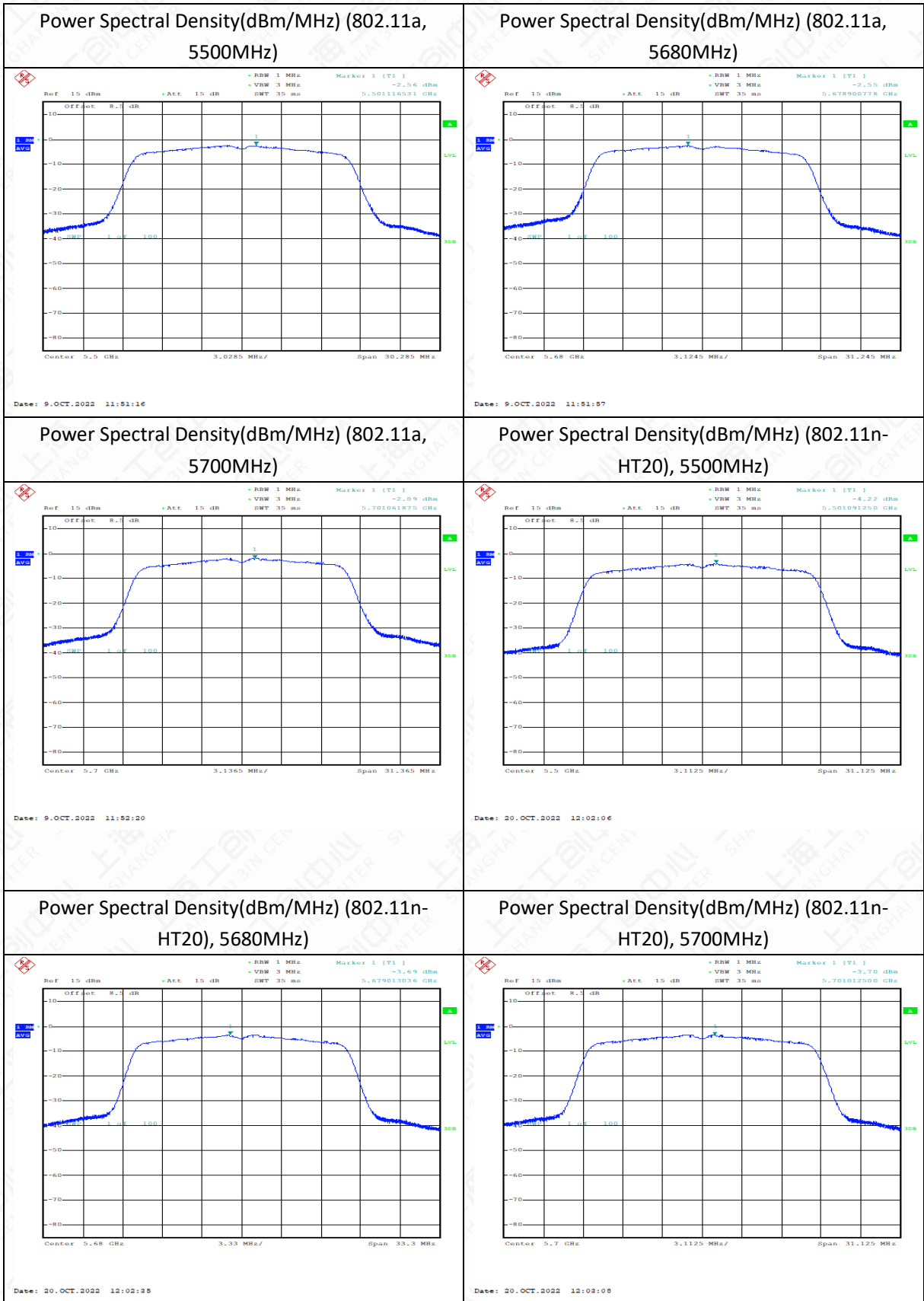

### 6.3 Occupied 26dB Bandwidth(conducted)

#### 6.3.1 Measurement Limit and Method

Standard	Limit(MHz)
FCC 47 CFR Part 15.407(a)	N/A

The measurement method is made according to KDB 789033 C

1. Set RBW = approximately 1% of the emission bandwidth
2. Set the VBW > RBW
3. Detector = Peak.
4. Trace mode = max hold.
5. Measure the maximum width of the emission that is 26 dB down from the maximum of the emission.

Compare this with the RBW setting of the analyzer. Readjust RBW and repeat measurement as needed until the RBW/EBW ratio is approximately 1%.

#### 6.3.2 Test Setup

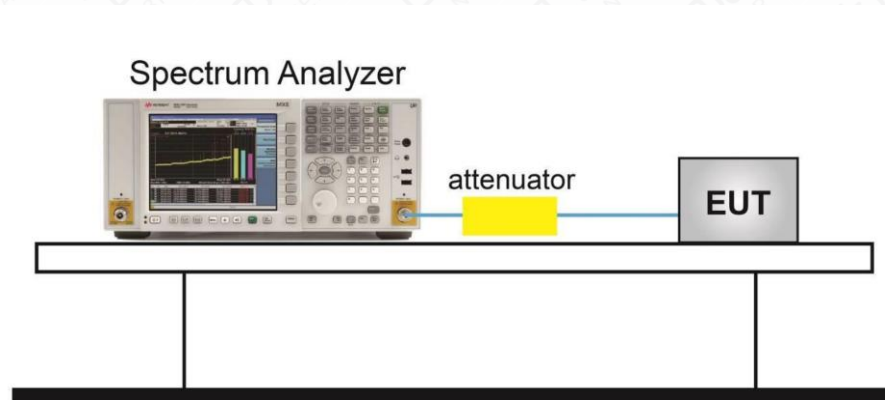

The measurement is made according to KDB 789033

#### 6.3.3 Measurement Results

U-NII-1:

Mode	Channel	Occupied 26dB Bandwidth (MHz)	Conclusion
802.11a	5180 MHz	20.27	P
	5200 MHz	21.64	P
	5240 MHz	22.12	P
802.11n HT20	5180 MHz	20.35	P
	5200 MHz	23.24	P
	5240 MHz	22.52	P

U-NII-2a

Mode	Channel	Occupied 26dB Bandwidth (MHz)	Conclusion
802.11a	5260 MHz	20.43	P
	5280 MHz	20.27	P
	5320 MHz	20.43	P
802.11n HT20	5260 MHz	21.88	P
	5280 MHz	20.11	P
	5320 MHz	20.59	P

## U-NII-2c

Mode	Channel	Occupied 26dB Bandwidth (MHz)	Conclusion
802.11a	5500 MHz	20.19	P
	5680 MHz	20.83	P
	5700 MHz	20.91	P
802.11n HT20	5500 MHz	20.75	P
	5680 MHz	22.20	P
	5700 MHz	20.75	P

## U-NII-1:

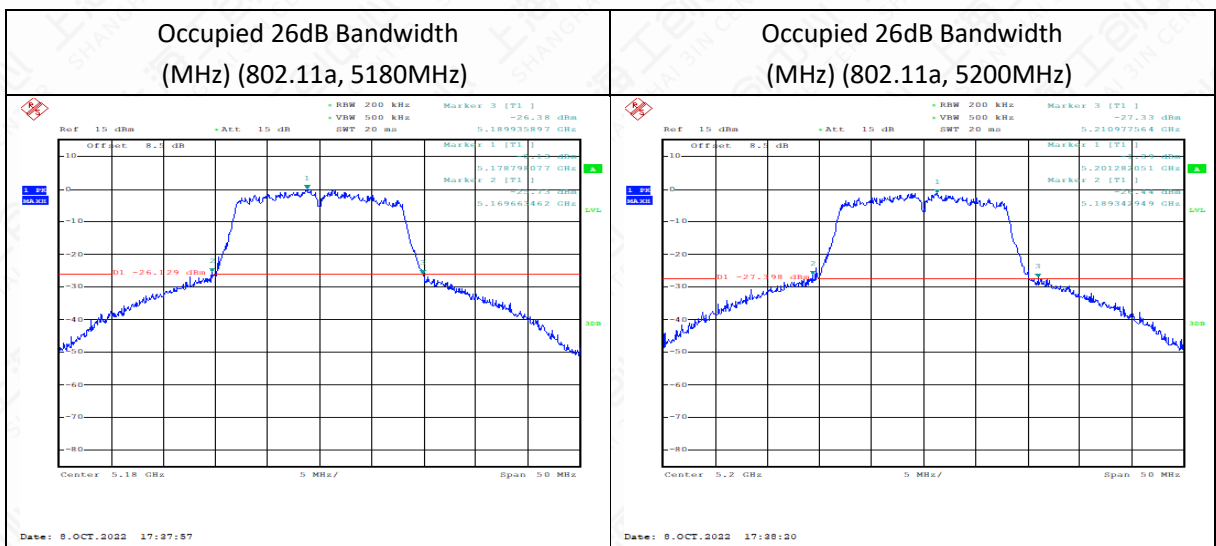



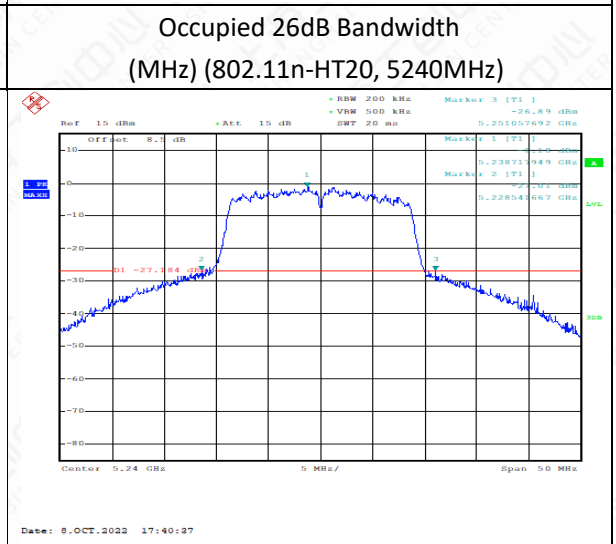
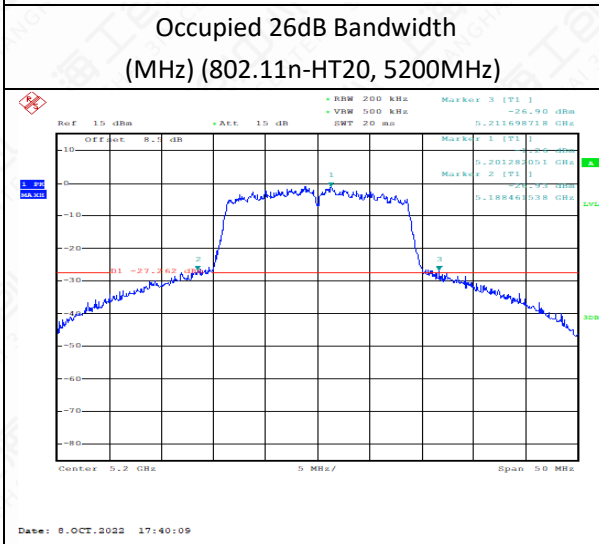
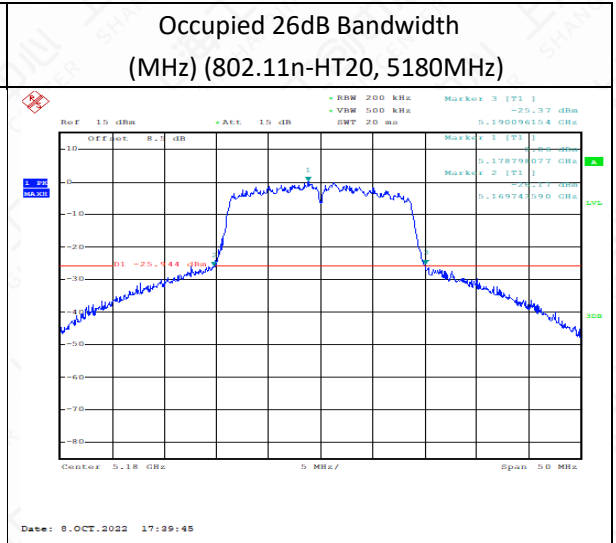
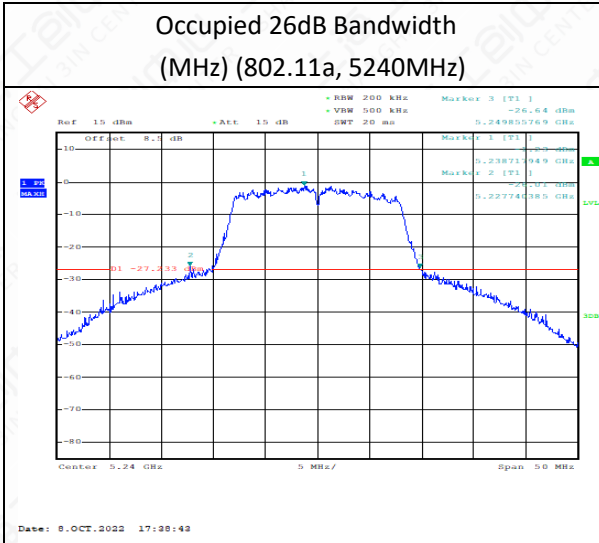

U-NII-2a:

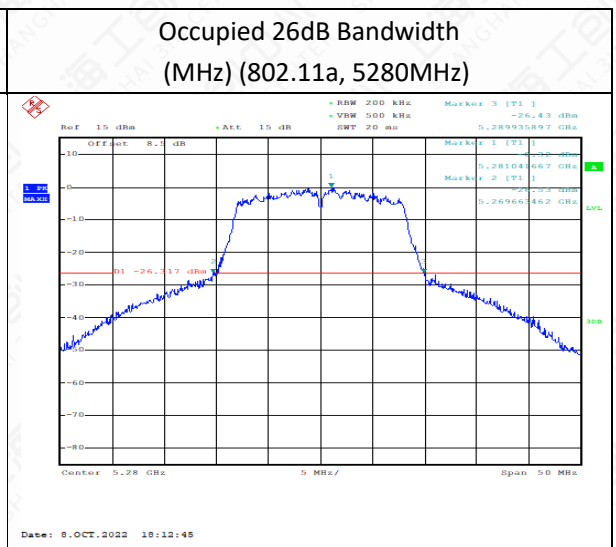
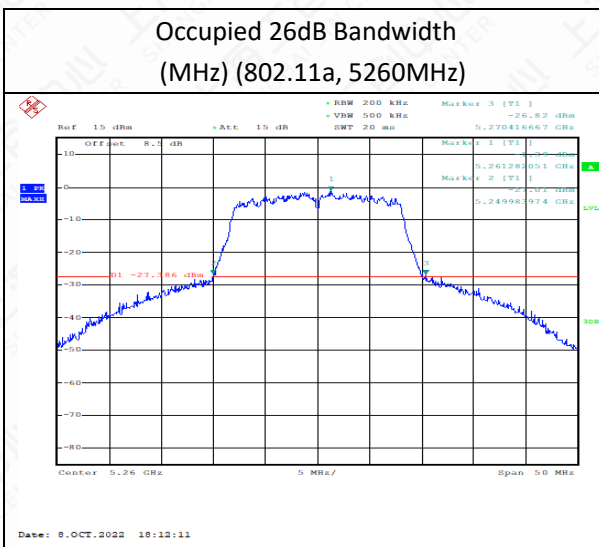

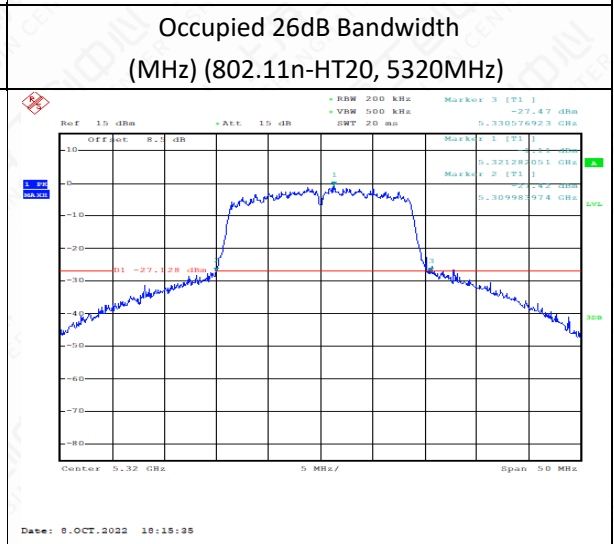
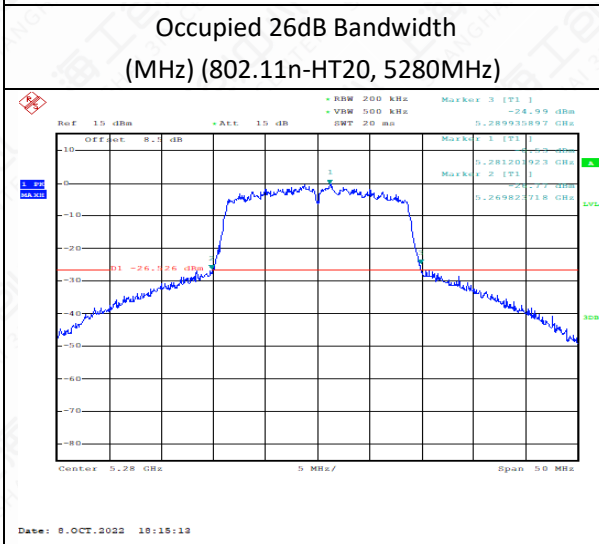
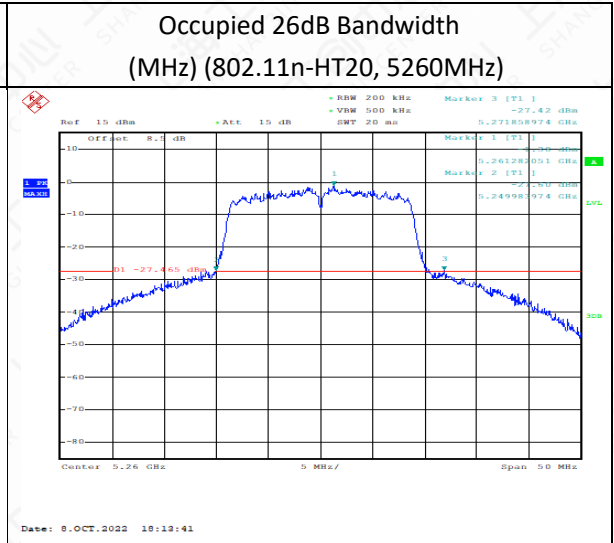
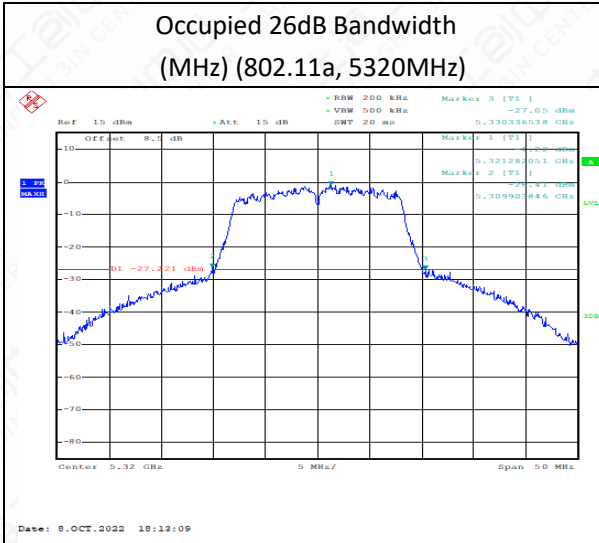
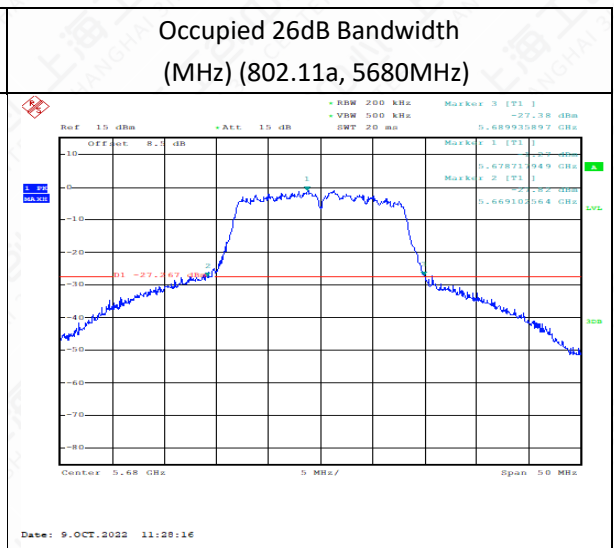
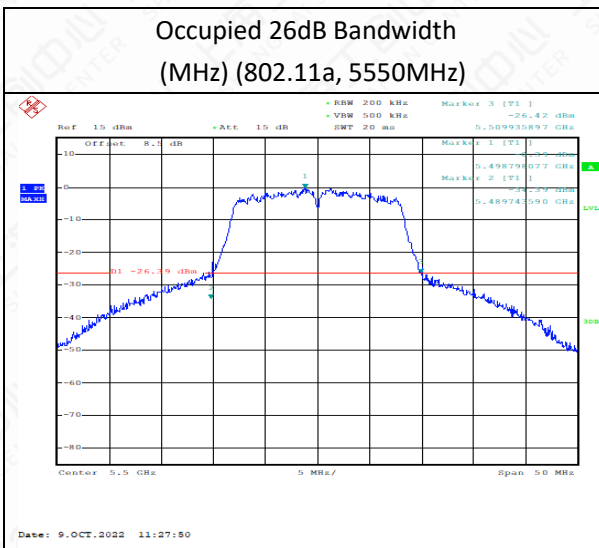
**U-NII-2c:**

Occupied 26dB Bandwidth

Occupied 26dB Bandwidth

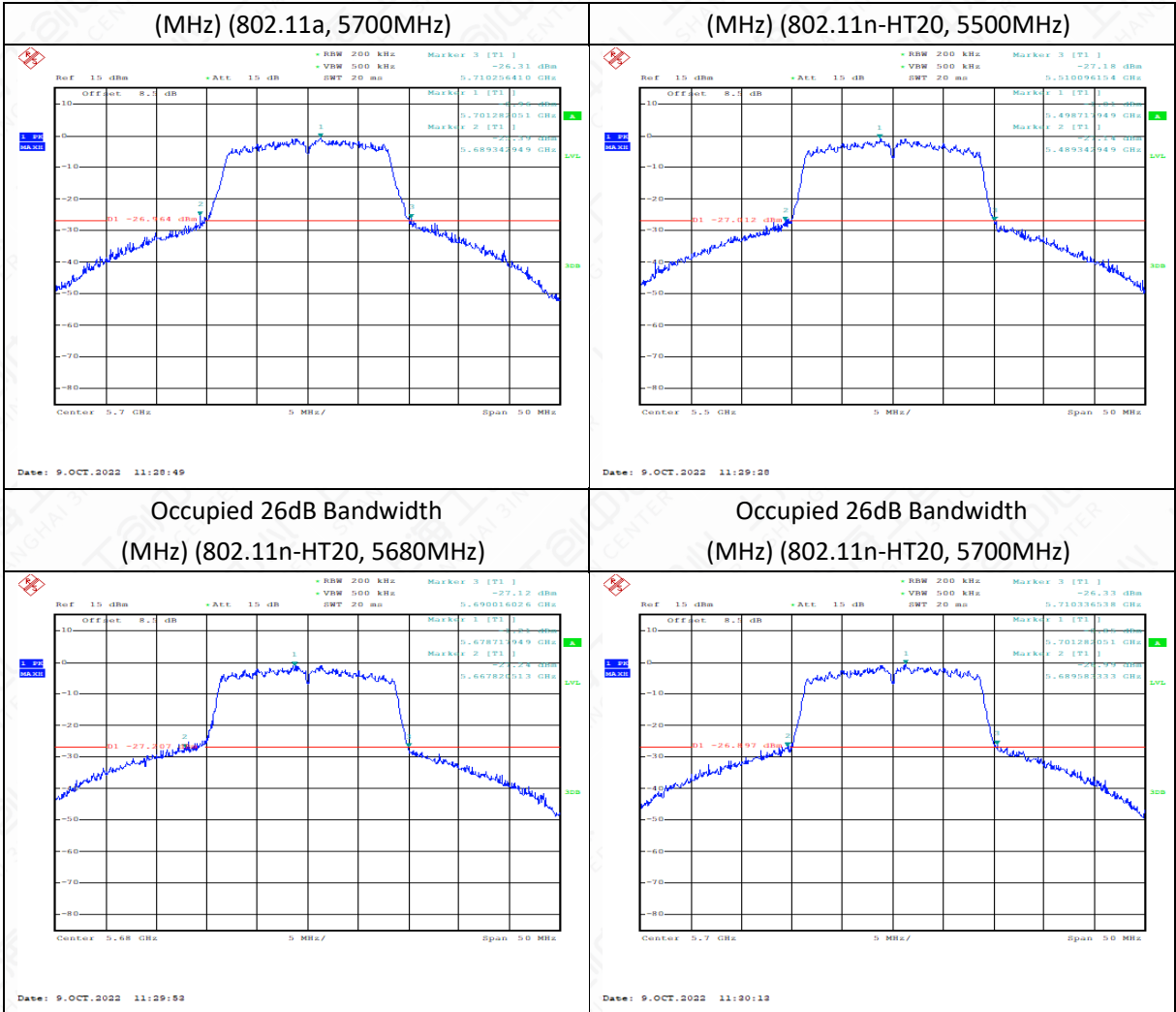

## 6.4 99% Occupied Bandwidth(conducted)

### 6.4.1 Measurement Limit and Method

Standard	Limit(MHz)
N/A	N/A

The measurement method is made according to KDB 789033 D

1. Set center frequency to the nominal EUT channel center frequency.
2. Set span = 1.5 times to 5.0 times the OBW.
3. Set RBW = 1 % to 5 % of the OBW
4. Set VBW  $\geq 3 \cdot$  RBW
5. Video averaging is not permitted. Where practical, a sample detection and single sweep mode shall be used. Otherwise, peak detection and max hold mode (until the trace stabilizes) shall be used.
6. Use the 99 % power bandwidth function of the instrument (if available).
7. If the instrument does not have a 99 % power bandwidth function, the trace data points are recovered and directly summed in power units. The recovered amplitude data points, beginning at the lowest frequency, are placed in a running sum until 0.5 % of the total is reached; that frequency is recorded as the lower frequency. The process is repeated until 99.5 % of the total is reached; that frequency is recorded as the upper frequency. The 99% occupied bandwidth is the difference between these two frequencies.

### 6.4.2 Test Setup

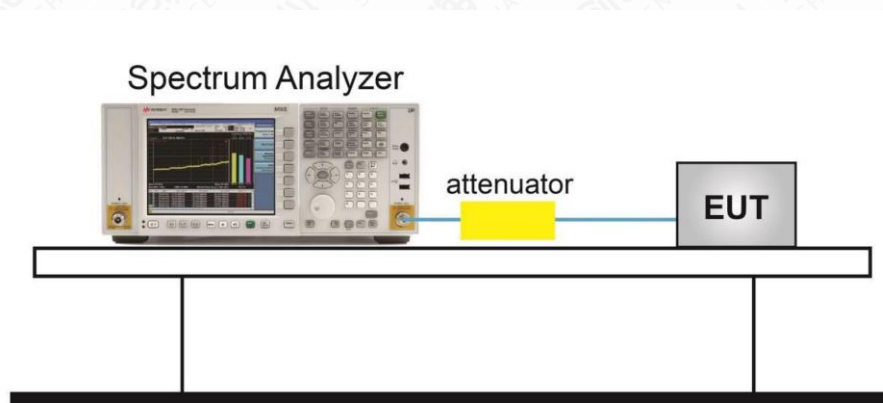

The measurement is made according to KDB 789033

## 6.4.3 Measurement Results

## U-NII-1:

Mode	Channel	99% Occupied Bandwidth (MHz)	Conclusion
802.11a	5180 MHz	16.747	P
	5200 MHz	16.747	P
	5240 MHz	16.667	P
802.11n HT20	5180 MHz	17.788	P
	5200 MHz	17.788	P
	5240 MHz	17.788	P

## U-NII-2a

Mode	Channel	99% Occupied Bandwidth (MHz)	Conclusion
802.11a	5260	16.987	P
	5280	16.827	P
	5320	17.067	P
802.11n HT20	5260	17.869	P
	5280	17.788	P
	5320	17.949	P

## U-NII-2c

Mode	Channel	99% Occupied Bandwidth (MHz)	Conclusion
802.11a	5500	20.19	P
	5680	20.83	P
	5700	20.91	P
802.11n HT20	5500	20.75	P
	5680	22.20	P
	5700	20.75	P

## U-NII-1:

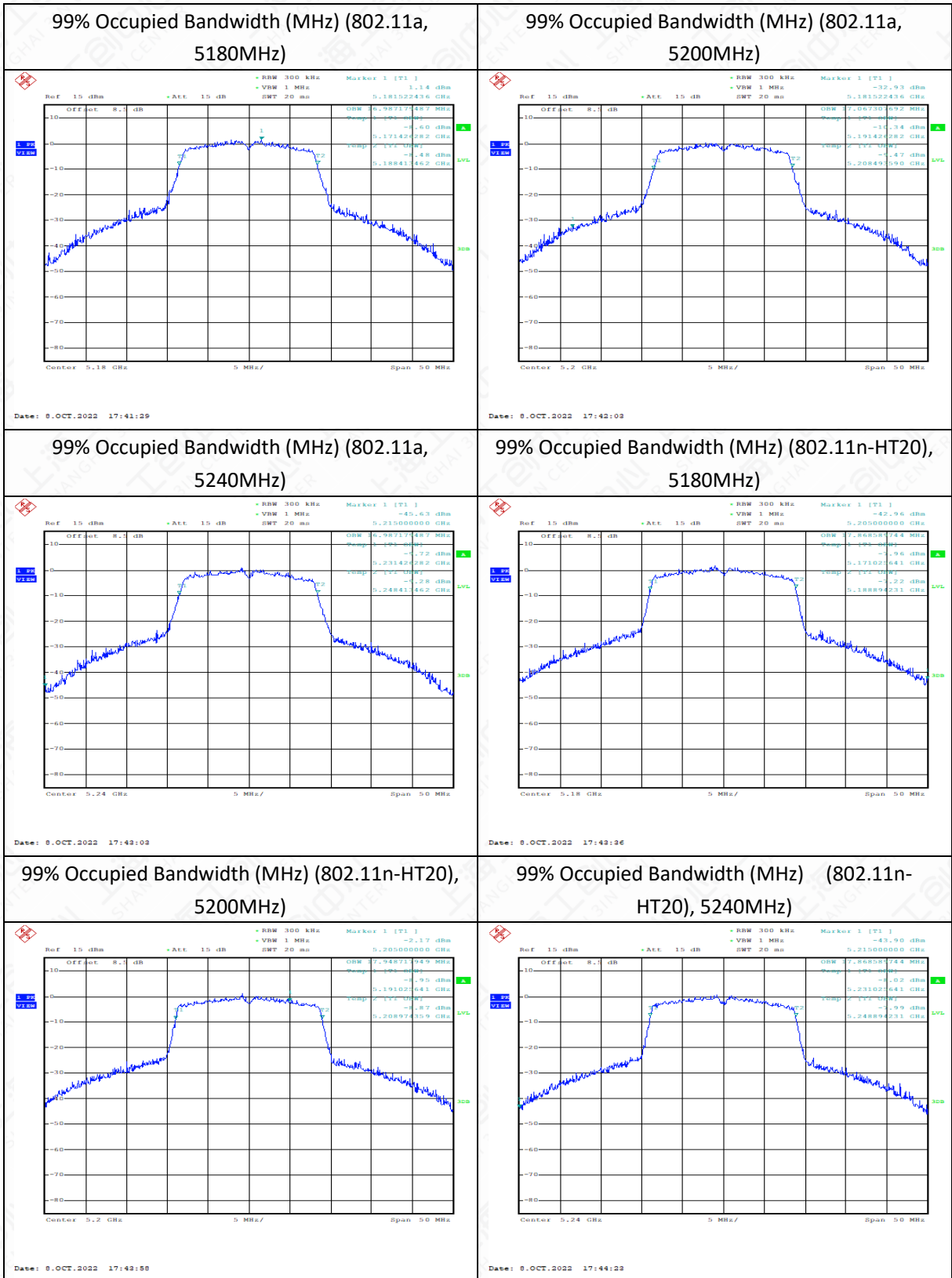

U-NII-2a:

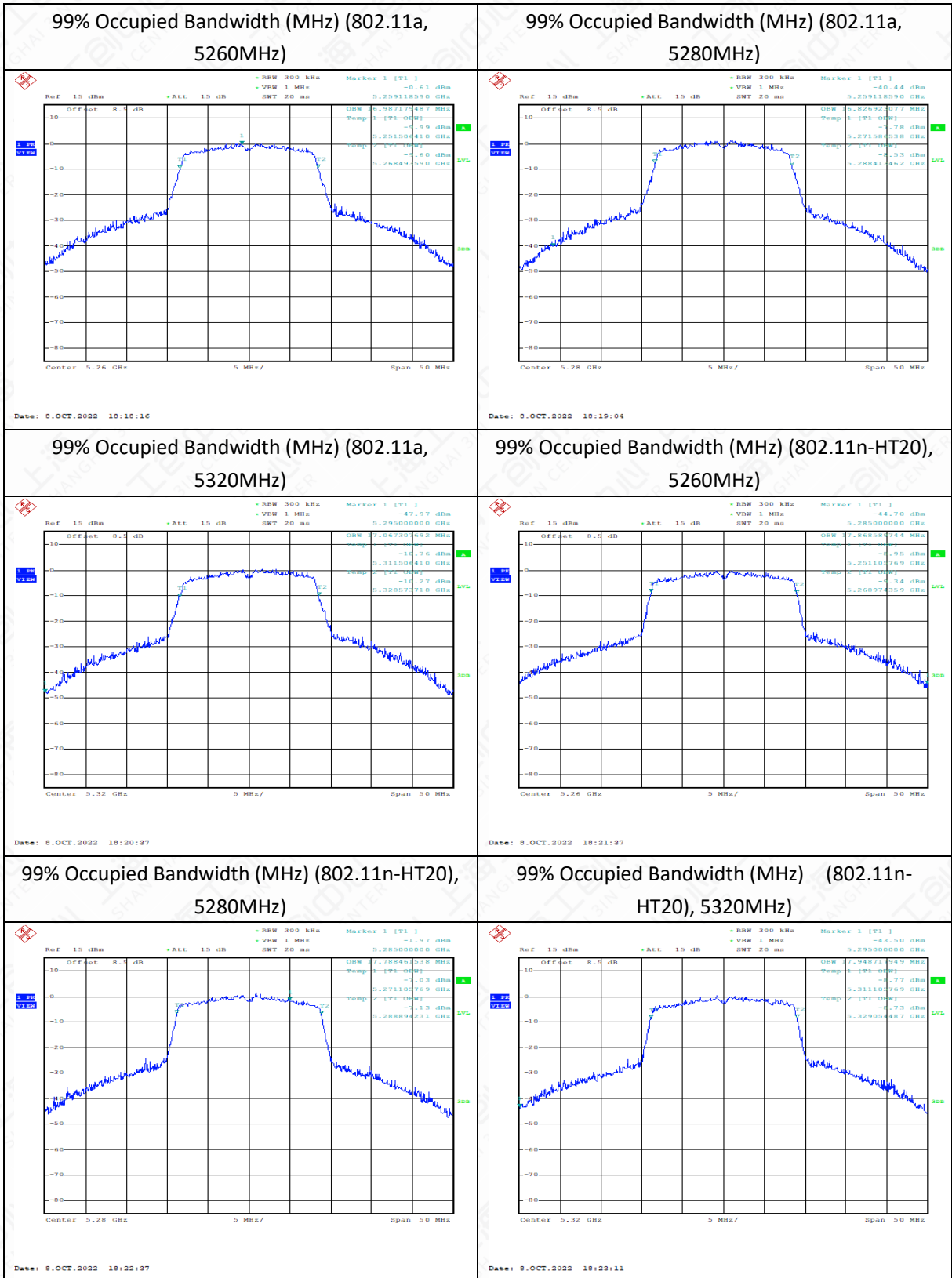

U-NII-2c:

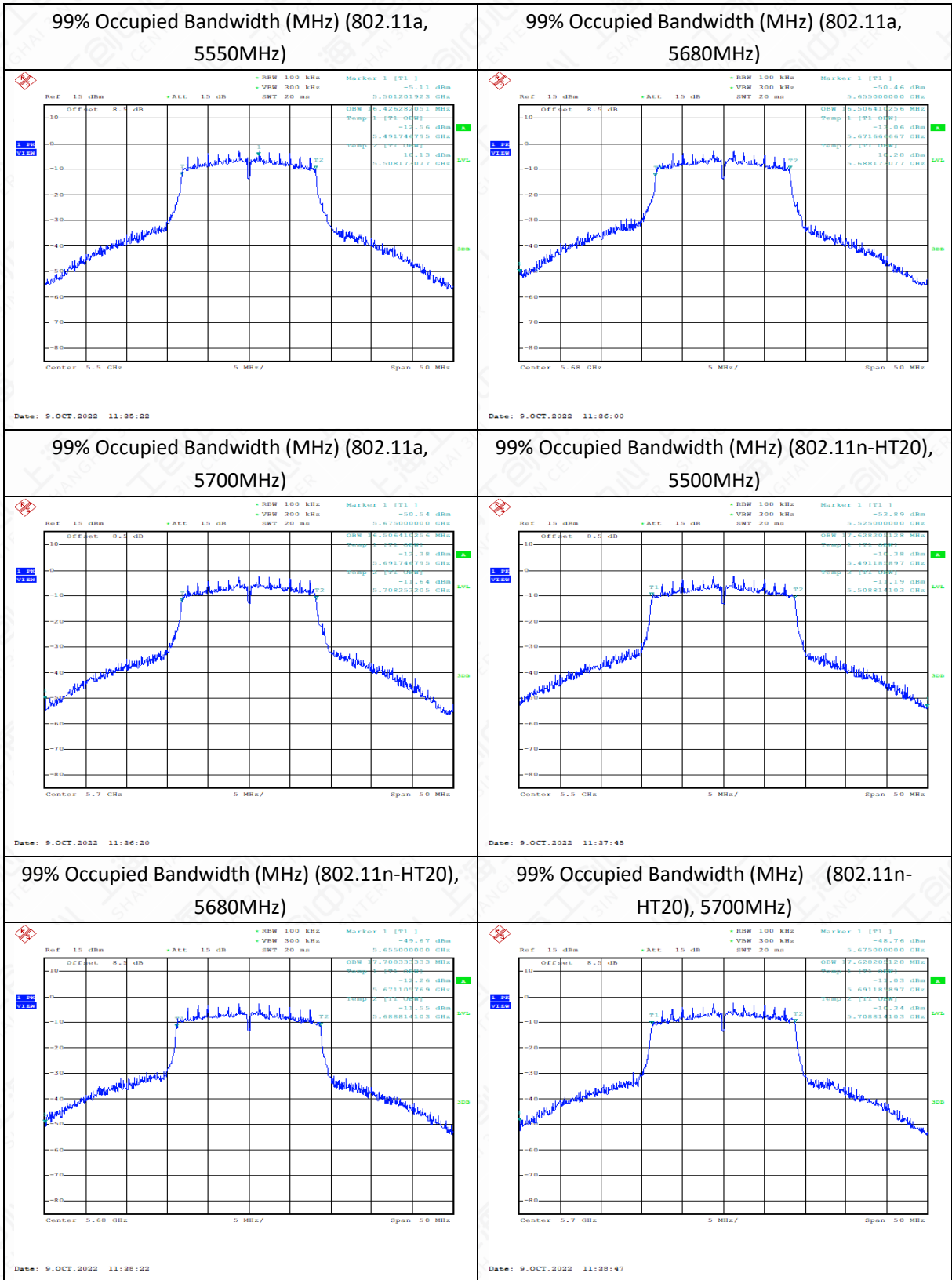



## 6.5 Band Edges Compliance

### 6.5.1 Band Edges – conducted

Measurement Limit and Method:

Standard	Limit(dBm/MHz)
FCC 47 CFR Part 15.407(b)(1)	< -27

Note: The test doesn't add the antenna gain to the test plots.

The measurement method is made according to KDB 789033 G(2)

1. For all measurements, follow the requirements in II.G.3. "General Requirements for Unwanted Emissions Measurements."
2. At frequencies below 1000 MHz, use the procedure described in II.G.4. "Procedure for Unwanted Emissions Measurements Below 1000 MHz."
3. At frequencies above 1000 MHz, use the procedure for maximum emissions described in II.G.5., "Procedure for Unwanted Emissions Measurements Above 1000 MHz."

(i) Sections 15.407(b)(1) to (b)(3) specify the unwanted emission limits for the U-NII-1 and U-NII-2 bands. As specified, emissions above 1000 MHz that are outside of the restricted bands are subject to a peak emission limit of -27 dBm/MHz.

(ii) Section 15.407(b)(4) specifies the unwanted emission limit for the U-NII-3 band. A band emissions mask is specified in Section 15.407(b)(4)(i). The emission limits are in terms of a Peak detector. An alternative to the band emissions mask is specified in Section 15.407(b)(4)(ii). The alternative limits are based on the highest antenna gain specified in the filing. There are also marketing and importation restrictions for the devices using the alternative limit.

#### 1.1.1.1 Test Setup

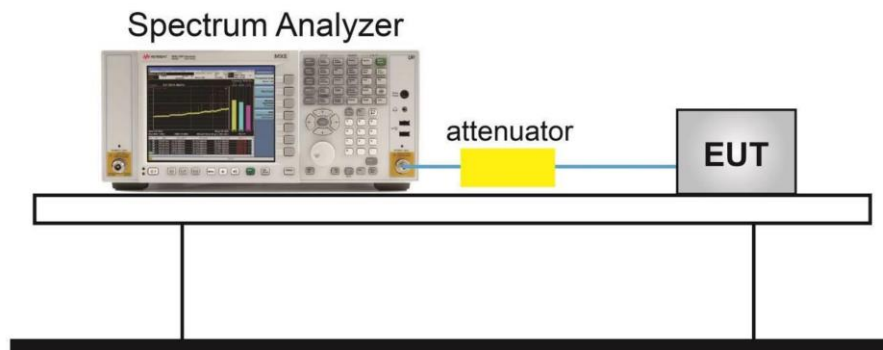

#### 1.1.1.2 Measurement Result

U-NII-1:

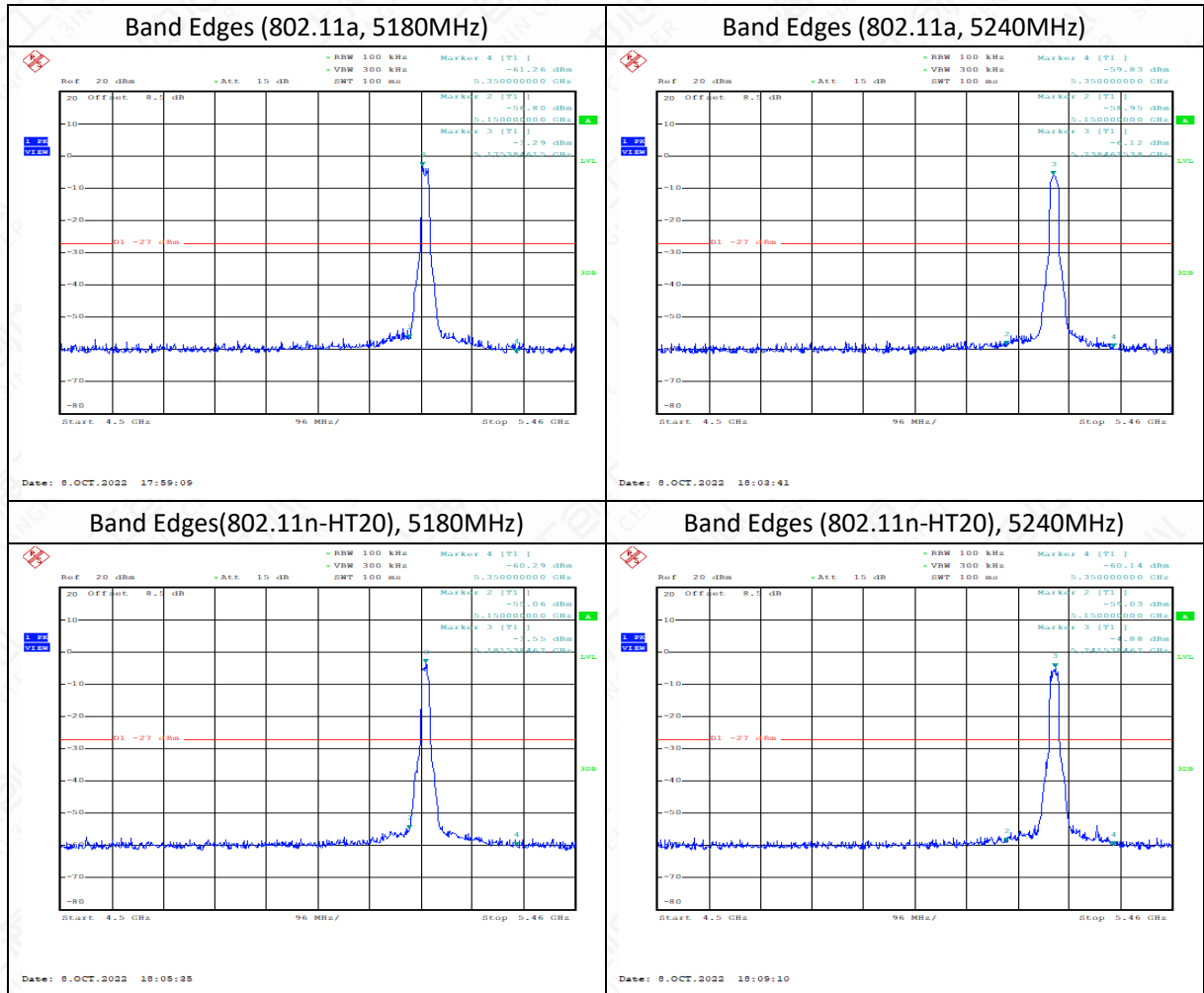

U-NII-2a:

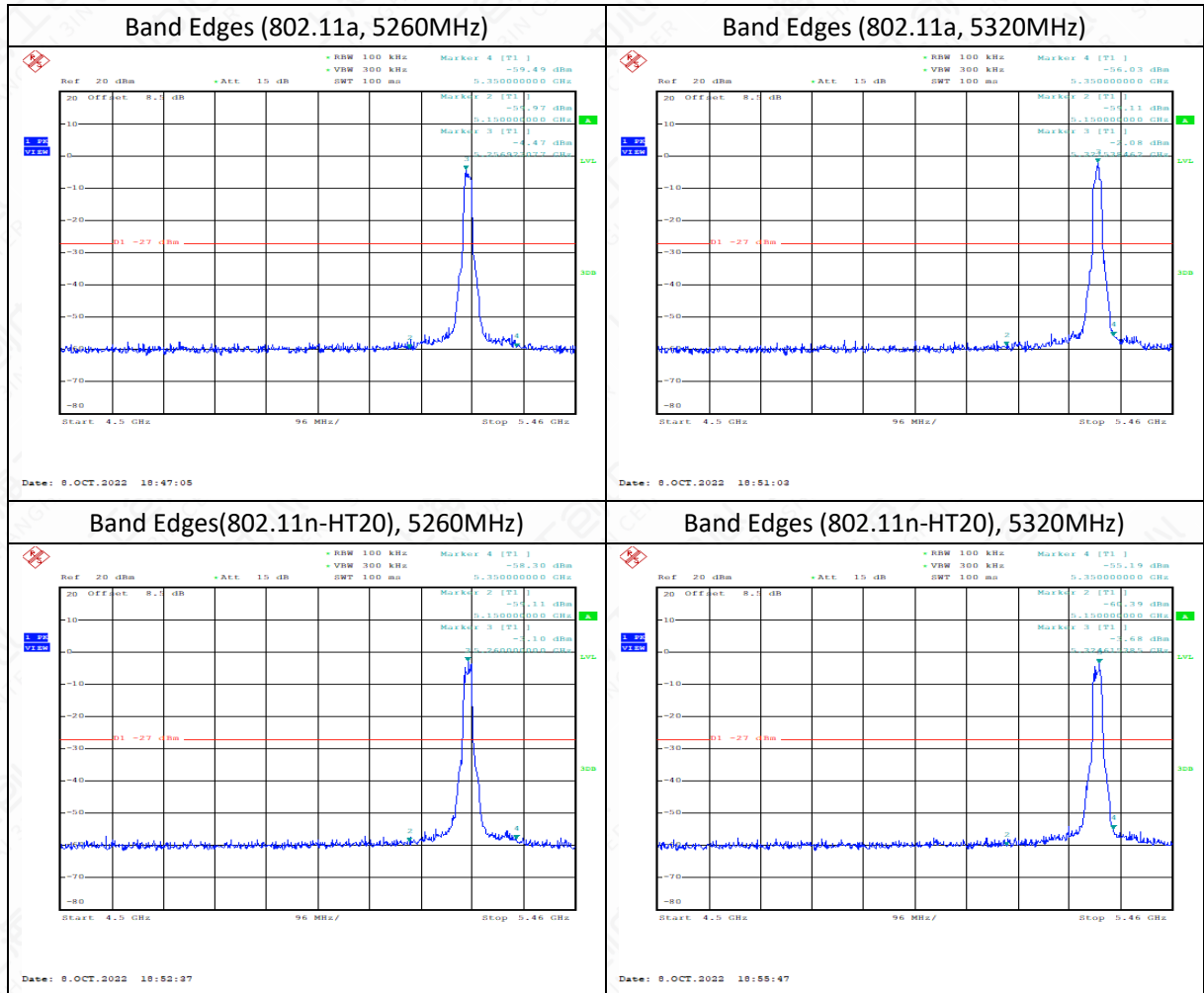

U-NII-2c:

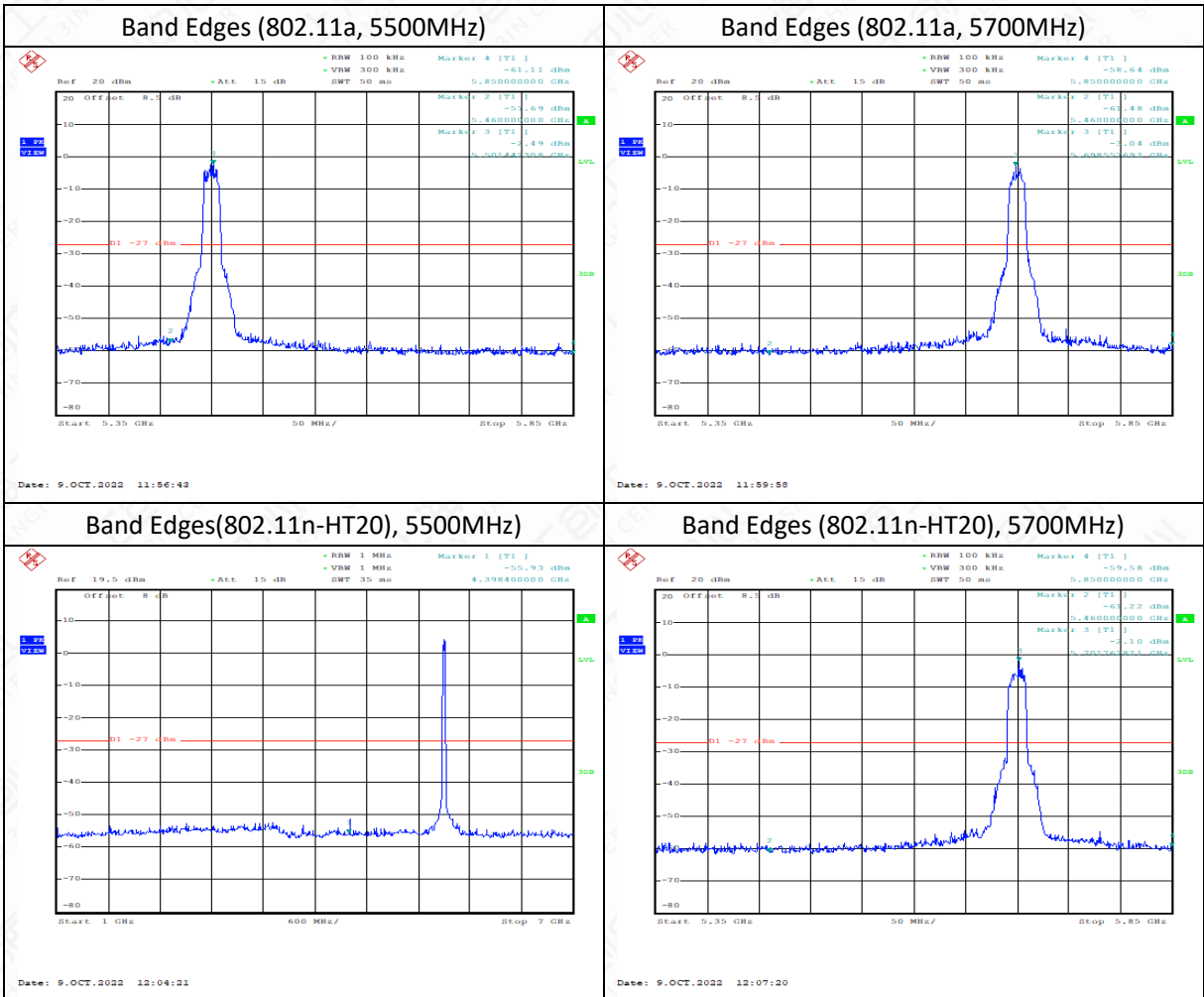

## 6.5.2 Band Edges - Radiated

### 6.5.2.1 Measurement Limit:

Standard	Limit (dB $\mu$ V/m)	
	FCC 47 CFR Part 15.209 & 15.407(b)(9),(10)	Peak
	Average	54

The measurement is made according to KDB 789033.

For maximum emissions measurements, follow the procedures described in II.G.5., “Procedures for Unwanted Maximum Emissions Measurements above 1000 MHz,” except for the following changes:

1. Set RBW = 100 kHz
2. Set VBW  $\geq 3 \times$  RBW
3. Perform a band-power integration across the 1 MHz bandwidth in which the band-edge emission level is to be measured. CAUTION: You must ensure that the spectrum analyzer or EMI receiver is set for peak-detection and max-hold for this measurement.

For average emissions measurements, follow the procedures described in II.G.6., “Procedures for Average Unwanted Emissions Measurements above 1000 MHz,” except for the following changes:

1. Set RBW = 100 kHz
2. Set VBW  $\geq 3 \times$  RBW
3. Perform a band-power integration across the 1 MHz bandwidth in which the band-edge emission level is to be measured.

### 6.5.2.2 Measurement Result

U-NII-1 :

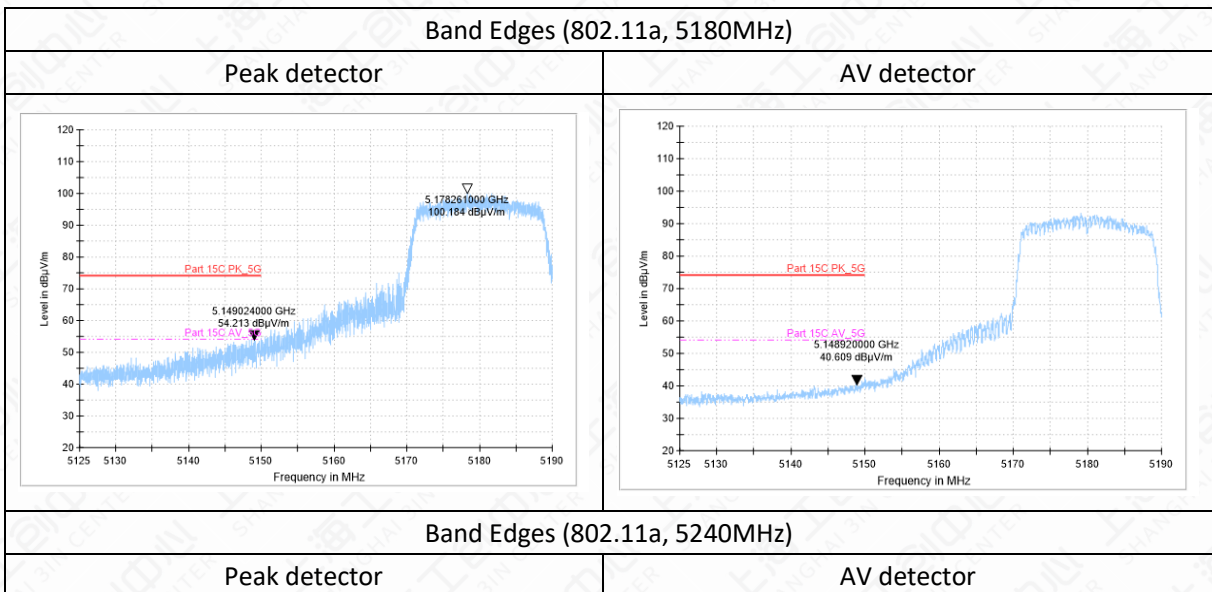

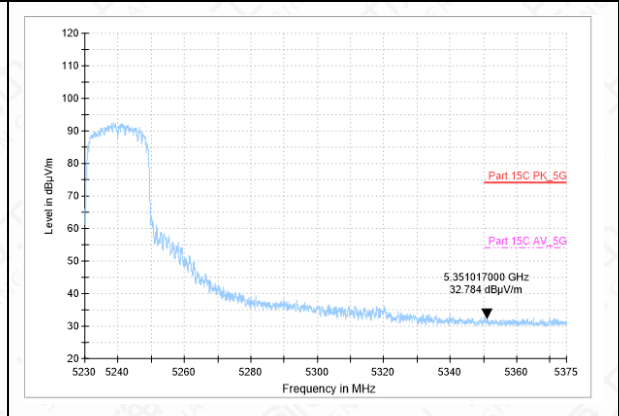
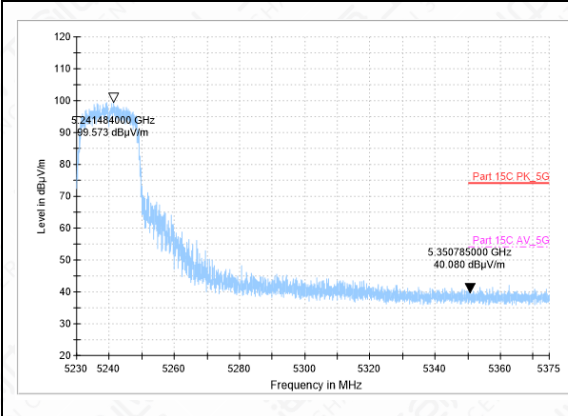

U-NII-2a :

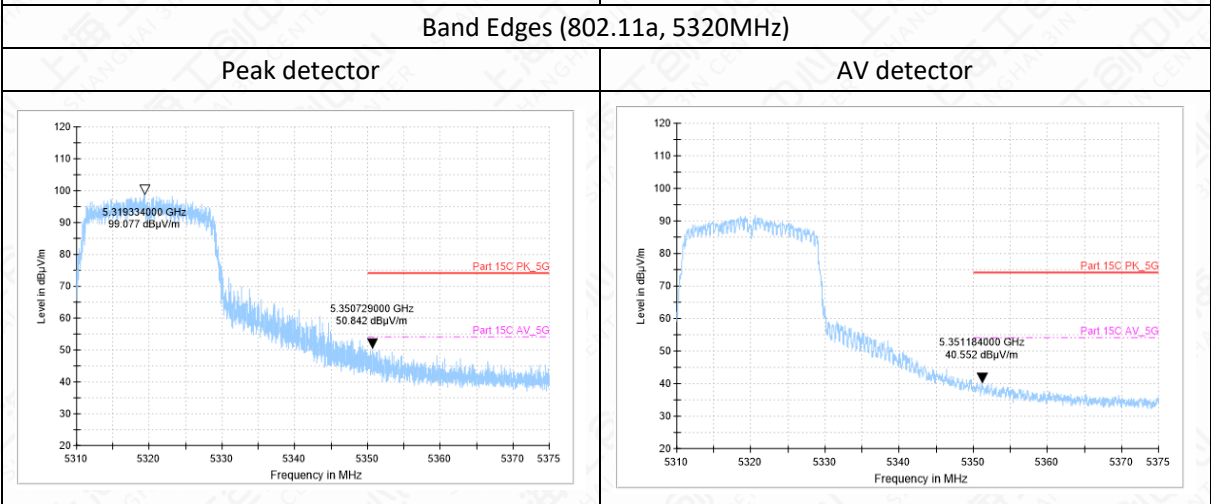
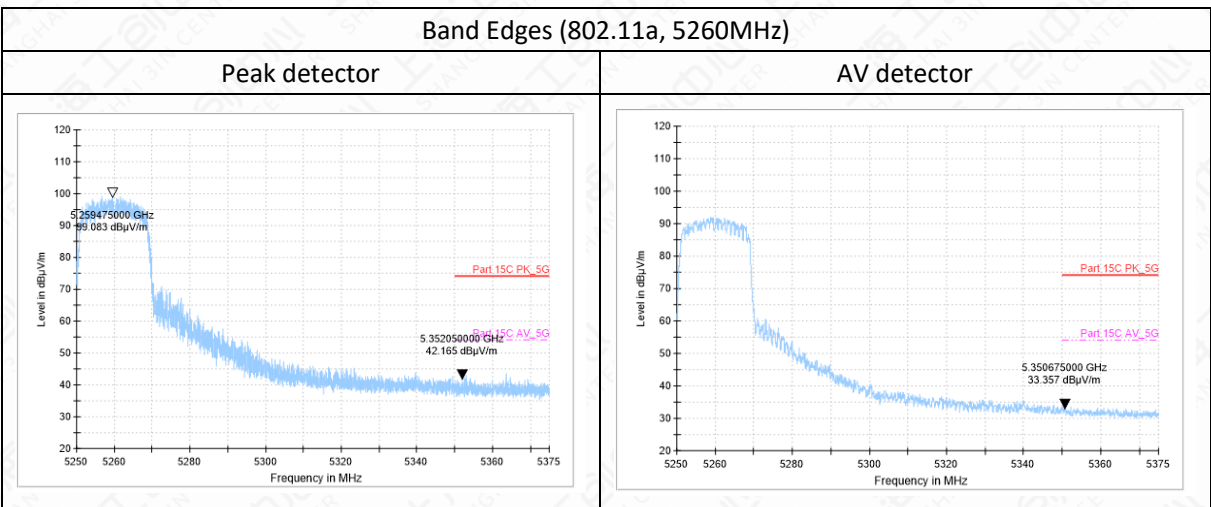

U-NII-2c :

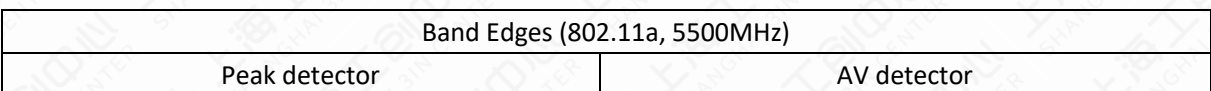

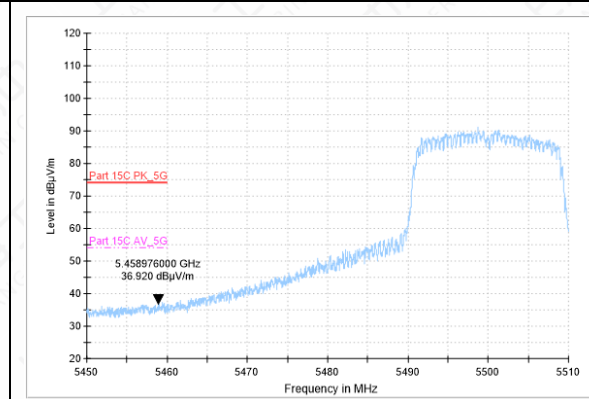
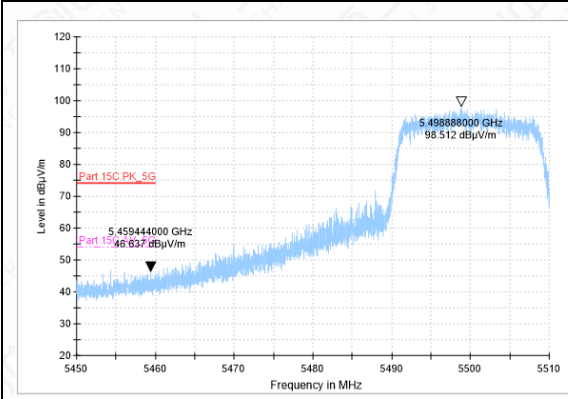

Band Edges (802.11a, 5700MHz)

Peak detector

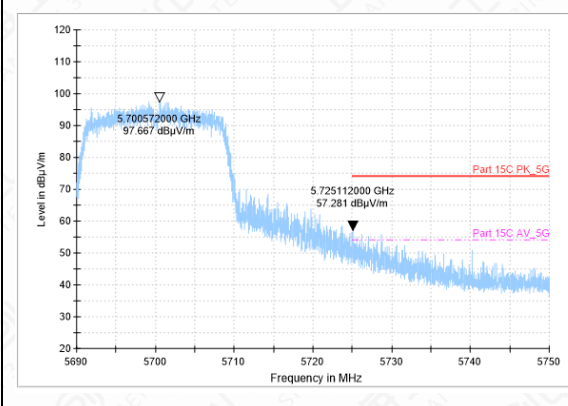

AV detector

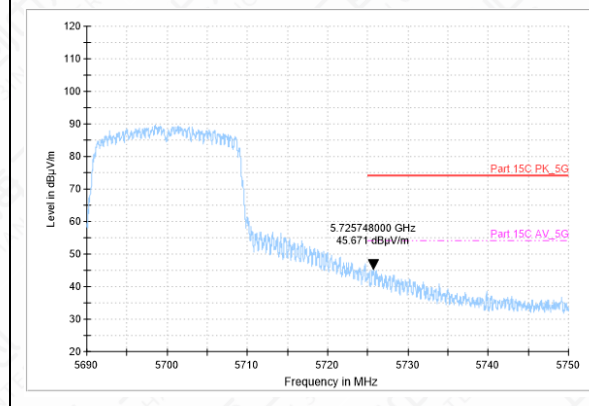

## 6.6 Transmitter Spurious Emission

### 6.6.1 Measurement Limit and Method

Standard	Limit(dB $\mu$ V/m)	
	FCC 47 CFR Part 15.209 & 15.407(b)(9),(10)	Peak
Average		54

The measurement is made according to KDB 789033

Set the spectrum analyzer in the following:

Below 1GHz:

- a) Follow the requirements in II.G.3. "General Requirements for Unwanted Emissions Measurements."
- b) Compliance shall be demonstrated using CISPR quasi-peak detection; however, peak detection is permitted as an alternative to quasi-peak detection.

Detector: Peak and Quasi-Peak

RBW=100kHz / VBW=300kHz / Sweep=AUTO

Above 1GHz (detector: Peak):

- a) Follow the requirements in II.G.3, "General Requirements for Unwanted Emissions Measurements."

- b) Maximum emission levels are measured by setting the analyzer as follows:

- (i) RBW = 1 MHz.
- (ii) VBW  $\geq$  3 MHz.
- (iii) Detector = Peak.
- (iv) Sweep time = auto.
- (v) Trace mode = max hold.
- (vi) Allow sweeps to continue until the trace stabilizes. Note that if the transmission is not continuous, the time required for the trace to stabilize will increase by a factor of approximately 1/x, where x is the duty cycle. For example, at 50% duty cycle, the measurement time will increase by a factor of two relative to measurement time for continuous transmission.

Limit in restricted band:

Frequency of emission (MHz)	Field strength(dB $\mu$ V/m)	Measurement distance(m)
0.009-0.490	129-94	3
0.490-1.705	74-63	3
1.705-30	70	3
30-88	40.0	3
88-216	43.5	3



216-960	46.0	3
Above 960	54.0	3

Note: for frequency range below 960MHz, the limit in 15.209 is defined in 10m test distance. The limit used above is calculated from 10m to 3m

### 6.6.2 Test Setup

#### Below 1GHz Test Setup

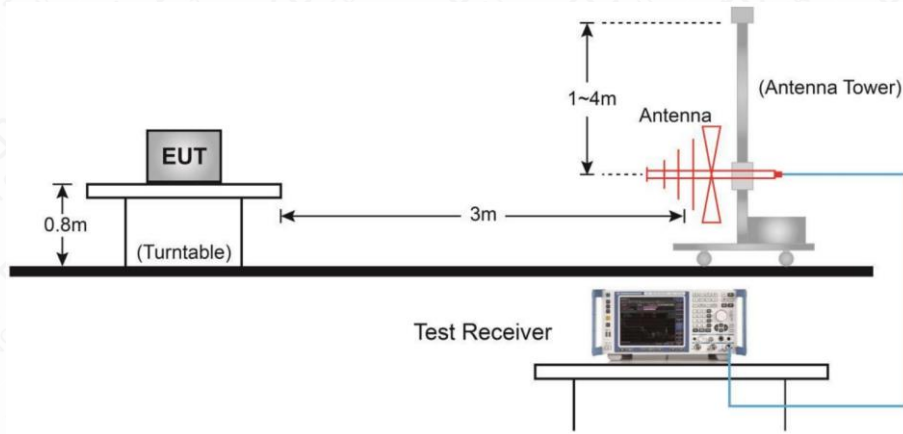

#### Above 1GHz Test Setup

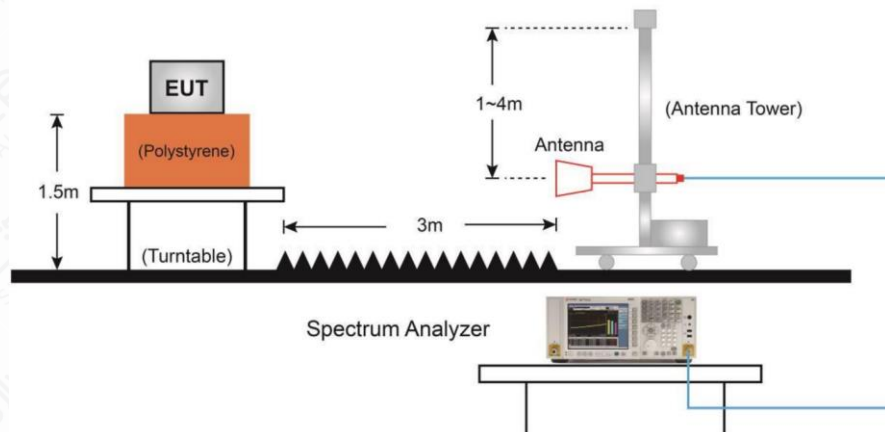

#### Test procedures

The measurement was applied in a semi-anechoic chamber. While testing for spurious emission higher than 1GHz, if applied, the pre-amplifier would be equipped just at the output terminal of the antenna.

Tabletop devices shall be placed on a nonconducting platform with nominal top surface dimensions 1 m by 1.5 m. For emissions testing at or below 1 GHz, the table height shall be 80 cm above the reference ground plane. For emission measurements above 1 GHz, the table height shall be 1.5 m.

The turntable rotated 360 degrees to determine the position of the maximum emission level.

The EUT was set 3 meters away from the receiving antenna which was mounted on an antenna mast. The antenna moved up and down between from 1meter to 4 meters to find out the maximum emission level.

The EUT was tested according to KDB 789033 D02: Section G.

The radiated emission was measured using the Spectrum Analyzer with the resolutions bandwidth set as:

RBW = 300 Hz, VBW = 1 kHz (9 kHz~150 kHz);

RBW = 10 kHz, VBW = 30 kHz (150 kHz~30MHz);

RBW = 100 kHz, VBW = 300 kHz (30MHz~1GHz for PK)

RBW = 1MHz, VBW = 3MHz (>1GHz for PK);

Remark:

1. Factor= Antenna Factor + Cable Loss (-Amplifier, is employed)
2. Measured level= Original Receiver Reading + Factor
3. Margin = Limit – Measured level
4. If the PK measured level is lower than AV limit, the AV test can be elided

The test data below 30MHz is more than 20dB lower than the limit value, so it is not provided in the report.

Modulation type and data rate tested (Only worst case result is given below):

**U-NII-1:**

Mode	Data rate	Channel
802.11a	6Mbps	36(5180MHz)
802.11n-HT20	MCS0	48(5240MHz)

**U-NII-2a:**

Mode	Data rate	Channel
802.11a	6Mbps	52(5260MHz)
802.11n-HT20	MCS0	64(5320MHz)

**U-NII-2c:**

Mode	Data rate	Channel
802.11a	6Mbps	100(5500MHz)
802.11n-HT20	MCS0	100(5500MHz)

6.6.3 Measurement Results

U-NII-1

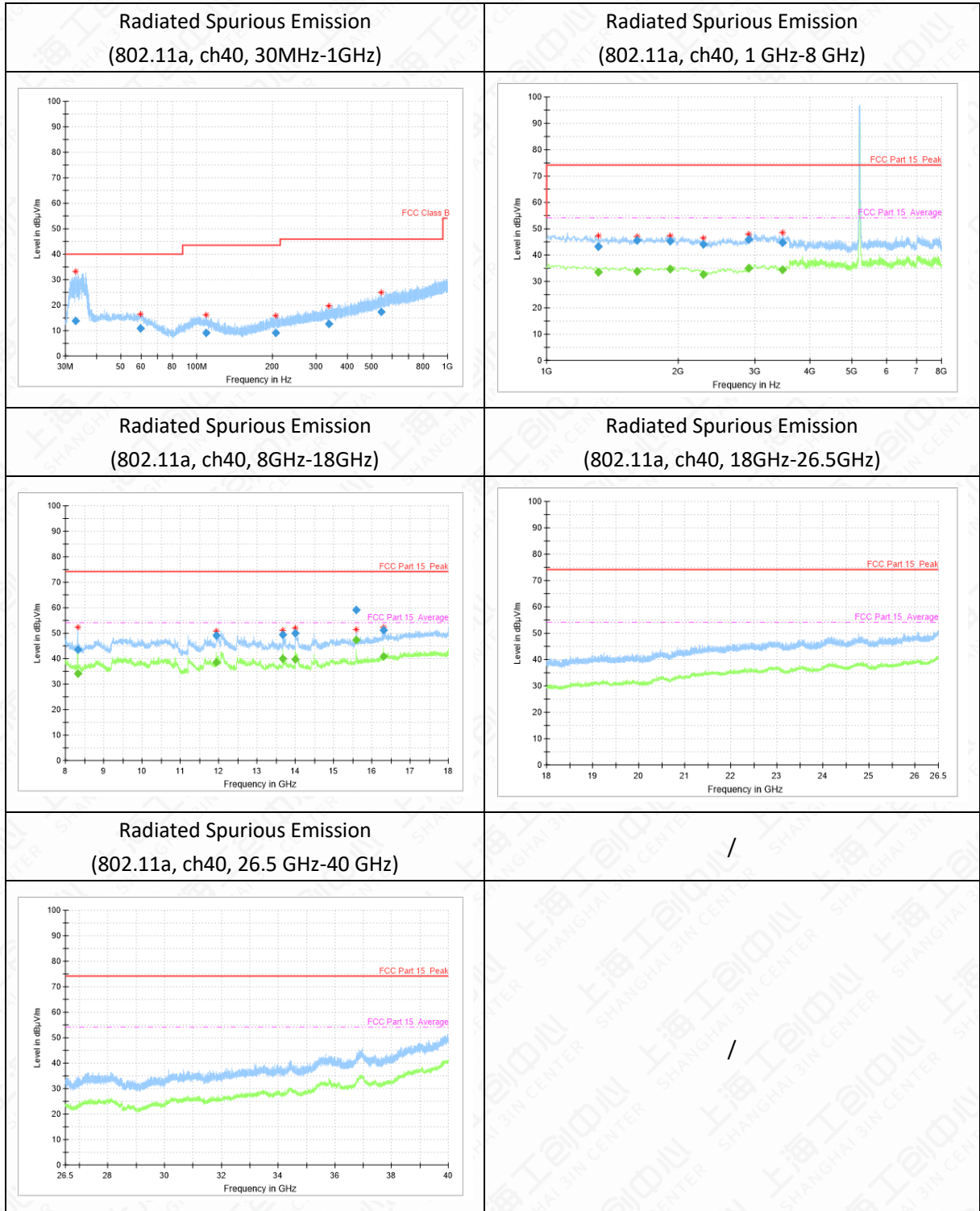

802.11a

## Channel 40( 30MHz ~1GHz )

Frequency(MHz)	Result(dBuV/m)	ARpl (dB)	PMea(dBuV/m)	Polarity
32.8	13.74	-14.3	28.04	V
59.8	10.83	-12.3	23.13	V
109.4	9.06	-13.4	22.46	H
206.2	9	-13.6	22.6	V
337.2	12.68	-9.8	22.48	V
544.5	17.41	-5.3	22.71	V

## Channel 40( 1GHz ~ 8GHz )

Frequency(MHz)	Result(dBuV/m)	ARpl (dB)	PMea(dBuV/m)	Polarity
1314.6	43.11	2	41.11	V
1609.8	45.61	1.8	43.81	V
1913.2	45.17	3	42.17	V
2284.0	44.24	1.6	42.64	V
2898.6	45.97	1.4	44.57	V
3461.2	44.62	1.1	43.52	V

## Channel 40( 8GHz ~ 18GHz )

Frequency(MHz)	Result(dBuV/m)	ARpl (dB)	PMea(dBuV/m)	Polarity
8318.0	43.47	3.9	39.57	V
11941.2	49	9.6	39.4	V
13680.2	49.5	11.6	37.9	H
14002.2	50.07	12.4	37.67	V
15601.6	59	14.4	44.6	V
16302.8	51.18	16.1	35.08	V

## Channel 40( 8GHz ~ 18GHz )(Average)

Frequency(MHz)	Result(dBuV/m)	ARpl (dB)	PMea(dBuV/m)	Polarity
15601.6	47.25	14.4	32.85	V

Note:

- The test data below 30MHz is more than 20dB lower than the limit value, so it is not provided in the report.

U-NII-2a

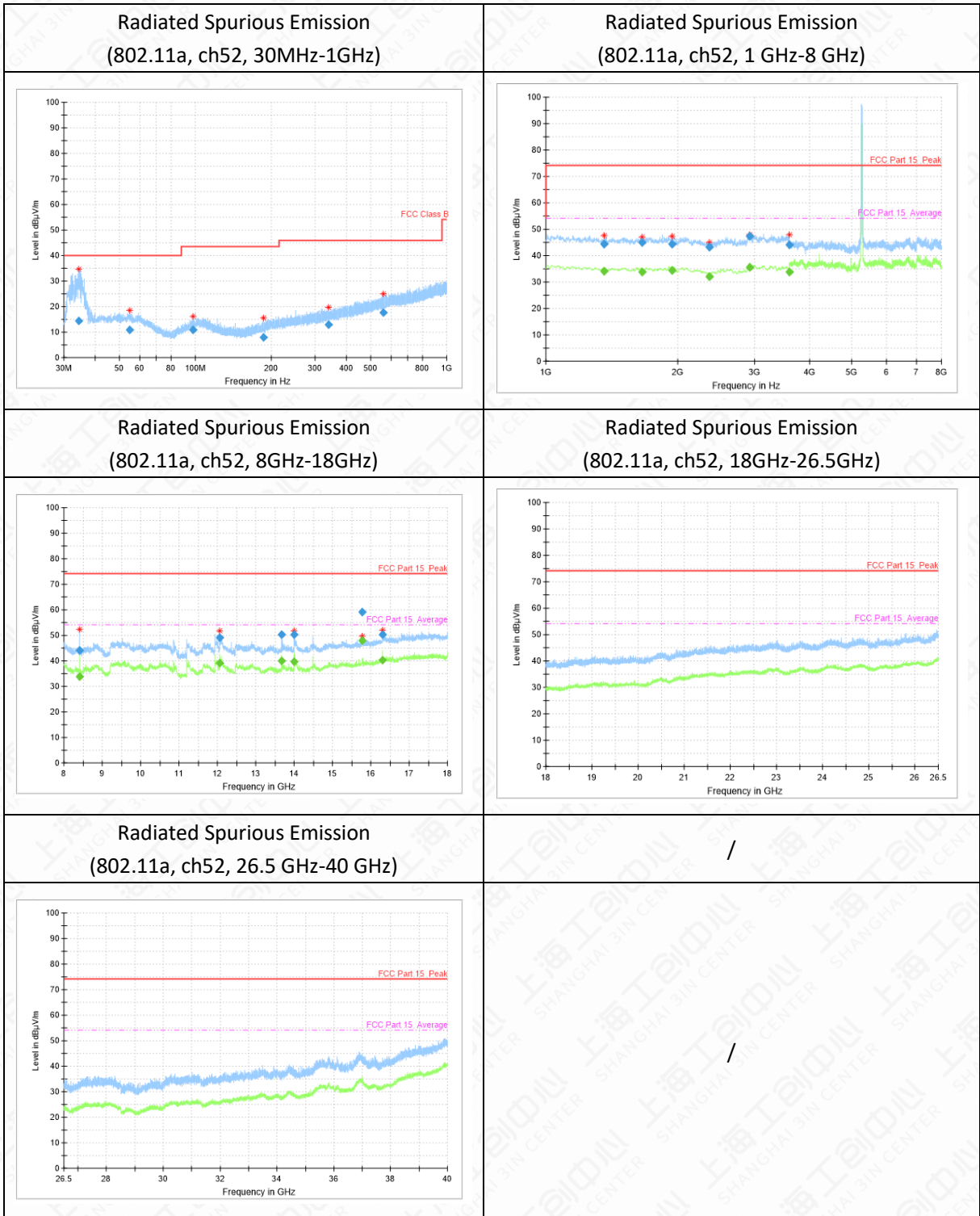

802.11a

Channel 52( 30MHz ~1GHz )

Frequency(MHz)	Result(dBuV/m)	ARpl (dB)	PMea(dBuV/m)	Polarity
34.4	14.46	-14.3	28.76	V
54.7	11.01	-12.1	23.11	H
98.2	10.98	-13.7	24.68	V
187.2	8.06	-14.5	22.56	V
339.6	12.85	-9.8	22.65	V
557.6	17.74	-4.8	22.54	H

Channel 52( 1GHz ~ 8GHz )

Frequency(MHz)	Result(dBuV/m)	ARpl (dB)	PMea(dBuV/m)	Polarity
1356.6	44.35	2.3	42.05	V
1660.6	44.91	1.9	43.01	V
1945.2	44.29	2.7	41.59	V
2364.2	43.32	0.8	42.52	V
2924.6	47.34	1.7	45.64	V
3596.6	44.24	1.2	43.04	V

Channel 52( 8GHz ~ 18GHz )

Frequency(MHz)	Result(dBuV/m)	ARpl (dB)	PMea(dBuV/m)	Polarity
8414.8	44.12	3.3	40.82	V
12055.0	49.24	10.2	39.04	V
13678.6	50.42	11.6	38.82	V
14001.2	50.28	12.4	37.88	H
15781.0	59.17	14.8	44.37	V
16306.4	50.3	16.1	34.2	H

Channel 40( 8GHz ~ 18GHz )(Average)

Frequency(MHz)	Result(dBuV/m)	ARpl (dB)	PMea(dBuV/m)	Polarity
15781.0	47.92	14.8	33.12	V

Note:

1. The test data below 30MHz is more than 20dB lower than the limit value, so it is not provided in the report.

U-NII-2c

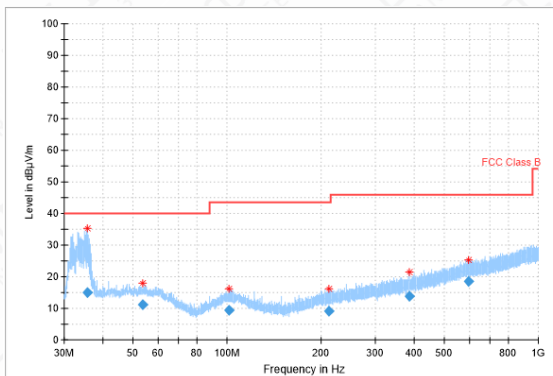
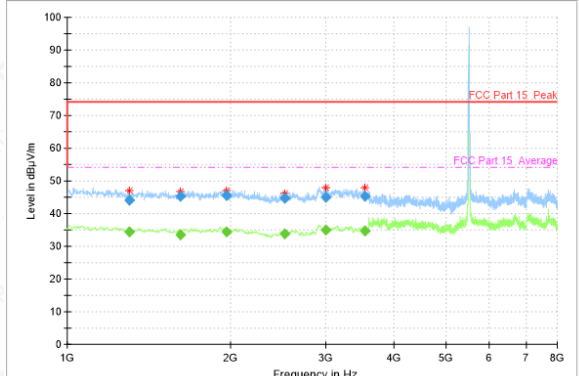
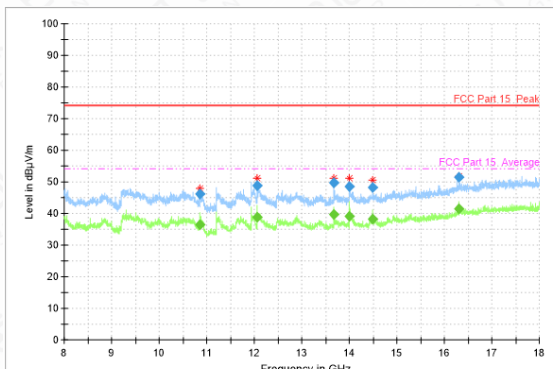
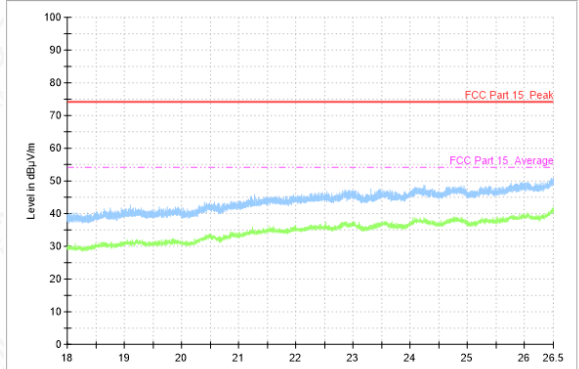
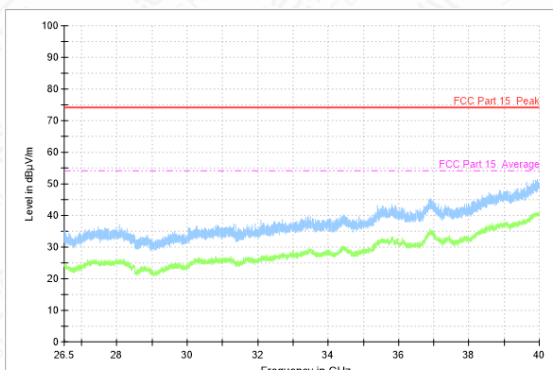
<p style="text-align: center;"><b>Radiated Spurious Emission</b> (802.11a, ch100, 30MHz-1GHz)</p> 	<p style="text-align: center;"><b>Radiated Spurious Emission</b> (802.11a, ch100, 1 GHz-8 GHz)</p> 
<p style="text-align: center;"><b>Radiated Spurious Emission</b> (802.11a, ch100, 8GHz-18GHz)</p> 	<p style="text-align: center;"><b>Radiated Spurious Emission</b> (802.11a, ch100, 18GHz-26.5GHz)</p> 
<p style="text-align: center;"><b>Radiated Spurious Emission</b> (802.11a, ch100, 26.5 GHz-40 GHz)</p> 	<p style="text-align: center;">/</p>

802.11a

Channel 100( 30MHz ~1GHz )

Frequency(MHz)	Result(dBuV/m)	ARpl (dB)	PMea(dBuV/m)	Polarity
35.5	15.11	-13.9	29.01	V
53.8	11.19	-12.1	23.29	V
101.9	9.28	-13.3	22.58	V
211.9	9.2	-13.4	22.6	V
384.9	13.89	-8.6	22.49	H
595.6	18.45	-3.8	22.25	V

Channel 100( 1GHz ~ 8GHz )

Frequency(MHz)	Result(dBuV/m)	ARpl (dB)	PMea(dBuV/m)	Polarity
1303.2	44.18	2.4	41.78	V
1619.4	45.37	1.8	43.57	V
1963.0	45.62	3	42.62	V
2520.0	44.77	1.6	43.17	V
2998.2	44.92	1.7	43.22	V
3533.4	45.16	1.2	43.96	V

Channel 100( 8GHz ~ 18GHz )

Frequency(MHz)	Result(dBuV/m)	ARpl (dB)	PMea(dBuV/m)	Polarity
10862.0	46.06	7	39.06	H
12053.0	48.86	10.2	38.66	H
13678.8	49.64	11.6	38.04	V
14002.0	48.56	12.4	36.16	V
14488.8	48.36	12.5	35.86	V
16303.0	51.42	16.1	35.32	H

Note:

- The test data below 30MHz is more than 20dB lower than the limit value, so it is not provided in the report.



## 6.7 Frequency Stability

Manufacturers ensured the EUT meet the requirement of frequency stability, such that an emission is maintained within the band of operation under all conditions of normal operation as specified in the user's manual.(According to 15.407(g)).

## 6.8 AC Powerline Conducted Emission

### 6.8.1 Method of Measurement: ANSI C63.10-2013-clause 6.2

1. The one EUT cable configuration and arrangement and mode of operation that produced the emission with the highest amplitude relative to the limit is selected for the final measurement, while applying the appropriate modulating signal to the EUT.
2. If the EUT is relocated from an exploratory test site to a final test site, the highest emissions shall be remaximized at the final test location before final ac power-line conducted emission measurements are performed.
3. The final test on all current-carrying conductors of all of the power cords to the equipment that comprises the EUT (but not the cords associated with other non-EUT equipment in the system) is then performed for the full frequency range for which the EUT is being tested for compliance without further variation of the EUT arrangement, cable positions, or EUT mode of operation.
4. If the EUT is comprised of equipment units that have their own separate ac power connections, e.g., floor-standing equipment with independent power cords for each shelf that are able to connect directly to the ac power network, each current-carrying conductor of one unit is measured while the other units are connected to a second (or more) LISN(s). All units shall be separately measured. If a power strip is provided by the manufacturer, to supply all of the units making up the EUT, only the conductors in the power cord of the power strip shall be measured.

If the EUT uses a detachable antenna, these measurements shall be made with a suitable dummy load connected to the antenna output terminals; otherwise, the tests shall be made with the antenna connected and, if adjustable, fully extended. When measuring the ac conducted emissions from a device that operates between 150 kHz and 30 MHz a non-detachable antenna may be replaced with a dummy load for the measurements within the fundamental emission band of the transmitter, but only for those measurements. Record the six highest EUT emissions relative to the limit of each of the current-carrying conductors of the power cords of the equipment that comprises the EUT over the frequency range specified by the procuring or regulatory agency. Diagram or photograph the test setup that was used. See Clause 8 for full reporting requirements.

6.8.2 Test Setup

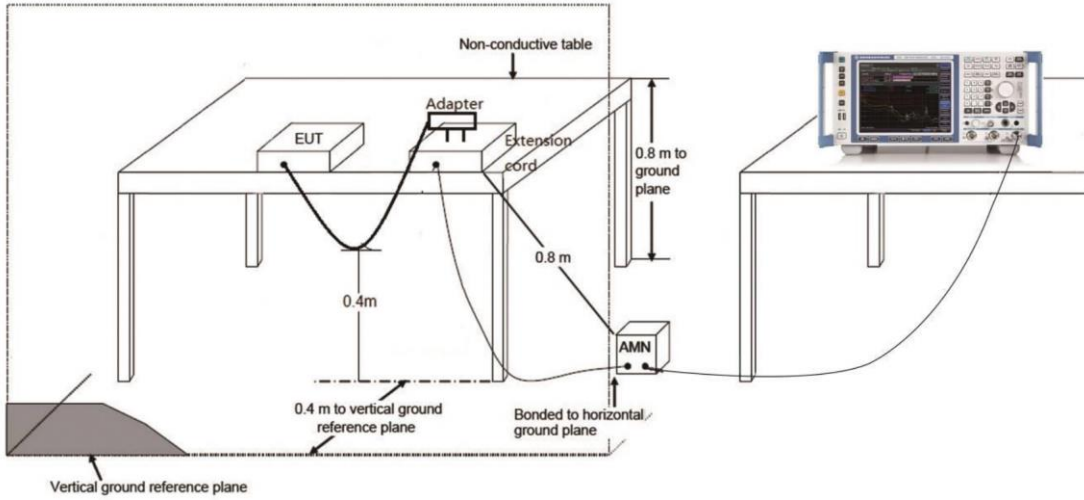

6.8.3 Test Condition

Voltage (V)	Frequency (Hz)
120	60

Measurement Result and limit:

(Quasi-peak-average Limit)

Frequency range (MHz)	Quasi-peak Limit (dBμV)	Average Limit (dBμV)	Conclusion
0.15 to 0.5	66 to 56	56 to 46	P
0.5 to 5	56	46	
5 to 30	60	50	

NOTE: The limit decreases linearly with the logarithm of the frequency in the range 0.15 MHz to 0.5 MHz.

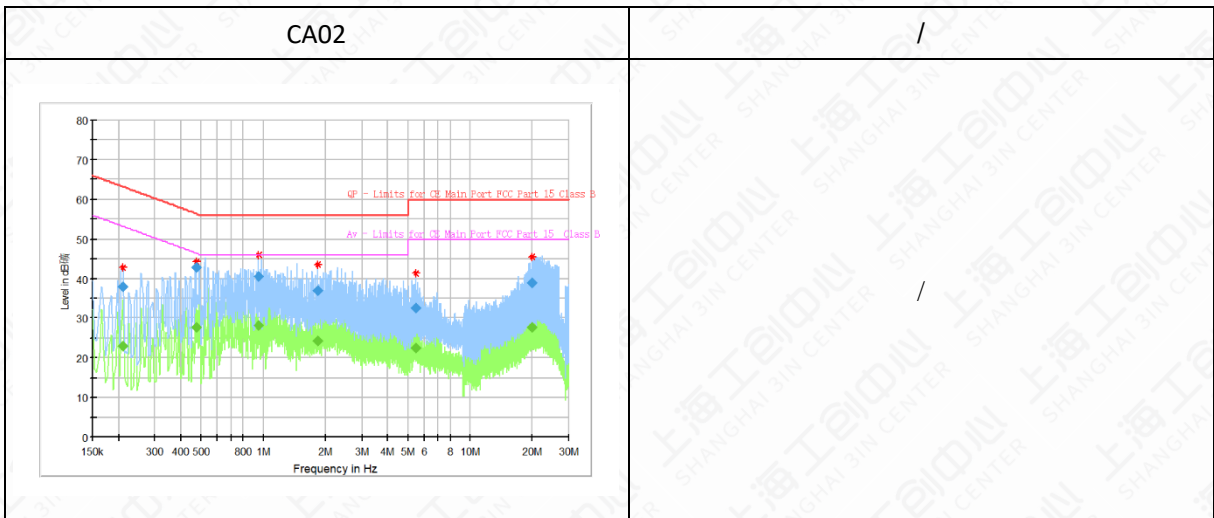

Frequency (MHz)	QuasiPeak (dBμV)	Average (dBμV)	Limit (dBμV)	Margin (dB)	Meas. Time (ms)	Bandwidth (kHz)	Line	Filter	Corr. (dB)
0.161194	---	24.38	55.40	31.03	15000.0	9.000	L1	ON	9.6
0.161194	38.17	---	65.40	27.23	15000.0	9.000	L1	ON	9.6
0.220894	---	22.04	52.79	30.74	15000.0	9.000	L1	ON	9.6
0.220894	37.99	---	62.79	24.79	15000.0	9.000	L1	ON	9.6
0.381338	---	26.12	48.25	22.13	15000.0	9.000	N	ON	8.4
0.381338	40.02	---	58.25	18.24	15000.0	9.000	N	ON	8.4
0.482081	---	25.06	46.30	21.25	15000.0	9.000	N	ON	9.5
0.482081	41.08	---	56.30	15.22	15000.0	9.000	N	ON	9.5
1.485788	---	24.63	46.00	21.37	15000.0	9.000	N	ON	9.7
1.485788	36.86	---	56.00	19.14	15000.0	9.000	N	ON	9.7
21.045000	---	28.32	50.00	21.68	15000.0	9.000	N	ON	10.2
21.045000	39.70	---	60.00	20.30	15000.0	9.000	N	ON	10.2

**Annex A: Revised History**

Version	Revised Content
V00	Initial

Annex B: Accreditation Certificate



Accredited Laboratory

A2LA has accredited

INDUSTRIAL INTERNET INNOVATION CENTER  
(SHANGHAI) CO., LTD.

Shanghai, People's Republic of China

for technical competence in the field of

Electrical Testing

This laboratory is accredited in accordance with the recognized International Standard ISO/IEC 17025:2017 General requirements for the competence of testing and calibration laboratories. This accreditation demonstrates technical competence for a defined scope and the operation of a laboratory quality management system (refer to joint ISO-ILAC-IAF Communiqué dated April 2017).

Presented this 12<sup>th</sup> day of April 2021.



Vice President, Accreditation Services  
For the Accreditation Council  
Certificate Number 3682.01  
Valid to February 28, 2023

For the tests to which this accreditation applies, please refer to the laboratory's Electrical Scope of Accreditation.

END OF REPORT