

Industrial Internet Innovation Center (Shanghai) Co.,Ltd.

FCC 2.4GWLAN TEST REPORT

PRODUCT	4G Smart Phone
BRAND	MobiWire,MobiWire,Vodafone,Orange
MODEL	H5028,Smart Green,Vodafone Lite,Orange Neva sparkle
APPLICANT	MobiWire SAS
FCC ID	QPN-H5028
ISSUE DATE	November 7, 2022
STANDARD(S)	FCC Part15

Prepared by: Tao Lingyan

Reviewed by: Yang Fan

Approved by: Zhang Min

Signature

Signature

Signature



CAUTION:

This report shall not be reproduced except in full without the written permission of the test laboratory and shall not be quoted out of context.

CONTENTS

1. SUMMARY OF TEST REPORT	3
1.1 TEST STANDARD(S)	3
1.2 REFERENCE DOCUMENTS.....	3
1.3 SUMMARY OF TEST RESULTS.....	3
1.4 DATA PROVIDED BY APPLICANT.....	4
2. GENERAL INFORMATION OF THE LABORATORY	5
2.1 TESTING LABORATORY	5
2.2 LABORATORY ENVIRONMENTAL REQUIREMENTS.....	5
2.3 PROJECT INFORMATION	5
3. GENERAL INFORMATION OF THE CUSTOMER	6
3.1 APPLICANT	6
3.2 MANUFACTURER	6
4. GENERAL INFORMATION OF THE PRODUCT.....	7
4.1 PRODUCT DESCRIPTION FOR EQUIPMENT UNDER TEST (EUT).....	7
4.2 INTERNAL IDENTIFICATION OF AE USED DURING THE TEST.....	7
4.3 ADDITIONAL INFORMATION	7
5. TEST CONFIGURATION INFORMATION	8
5.1 LABORATORY ENVIRONMENTAL CONDITIONS.....	8
5.2 TEST EQUIPMENTS UTILIZED.....	8
5.3 MEASUREMENT UNCERTAINTY	10
6. TEST RESULTS	11
6.1 OUTPUT POWER-CONDUCTED	11
6.2 PEAK POWER SPECTRAL DENSITY	15
6.3 OCCUPIED 6dB BANDWIDTH.....	19
6.4 99% OCCUPIED BANDWIDTH.....	22
6.5 BAND EDGES COMPLIANCE.....	25
6.6 TRANSMITTER SPURIOUS EMISSION-CONDUCTED.....	27
6.7 TRANSMITTER SPURIOUS EMISSION-RADIATED	31
6.8 AC POWERLINE CONDUCTED EMISSION	36
ANNEX A: REVISED HISTORY	39
ANNEX B: ACCREDITATION CERTIFICATE.....	40

1. Summary of Test Report

1.1 Test Standard(s)

No.	Test Standard(s)	Title	Version
1	FCC Part15	FCC CFR 47, Part 15, Subpart C: 15.205 Restricted bands of operation; 15.209 Radiated emission limits, general requirements; 15.247 Operation within the bands 902-928MHz, 2400-2483.5MHz, and 5725-5850MHz.	2020

1.2 Reference Documents

No.	Reference	Title	Version
1	ANSI C63.10	American National Standard of Procedures for Compliance Testing of Unlicensed Wireless Devices	2013
2	KDB 558074	Guidance for Performing Compliance Measurements on Frequency Hopping Spread Spectrum systems (DSS) Operating Under §15.247	2019

1.3 Summary of Test Results

Measurement Items	Sub-clause of Part15C	Verdict
Maximum Peak Output Power	15.247(b)	Pass
Peak Power Spectral Density	15.247(e)	Pass
6dB Occupied Bandwidth	15.247(a)	Pass
99% Occupied Bandwidth	15.247(a)	Pass
Band Edges Compliance	15.247(d)	Pass
Transmitter Spurious Emission-Conducted	15.247(d)	Pass
Transmitter Spurious Emission-Radiated	15.247/15.205/15.209	Pass
AC Powerline Conducted Emission	15.207	Pass

NOTE:

The H5028, Smart Green, Vodafone Lite, Orange Neva sparkle, manufactured by MobiWire SAS is a new product for testing.

Industrial Internet Innovation Center (Shanghai) Co., Ltd. only performed test cases which identified with Pass/Fail/Inc result in section 1.2.

Industrial Internet Innovation Center (Shanghai) Co., Ltd. has verified that the compliance of the tested device specified in section 4 of this test report is successfully evaluated according to the procedure and test methods as defined in type certification requirement listed in section 1 of this test report.

1.4 Data Provided by Applicant

No.	Item(s)	Data
1	Antenna gain of EUT	-1 dBi

Note: The data of 1.4 is provided by the customer may affect the validity of the test results in this report, and the impact and consequences of this shall be undertaken by the customer.

2. General Information of The Laboratory

2.1 Testing Laboratory

Lab Name	Industrial Internet Innovation Center (Shanghai) Co.,Ltd.
Address	Building 4, No. 766, Jingang Road, Pudong, Shanghai, China
Telephone	021-68866880
FCC Registration No.	958356
FCC Designation No.	CN1177

2.2 Laboratory Environmental Requirements

Temperature	15°C~35°C
Relative Humidity	25%RH~75%RH
Atmospheric Pressure	101kPa

2.3 Project Information

Project Manager	Xu Yuting
Test Date	September 4,2022 to October 20, 2022

3. General Information of The Customer

3.1 Applicant

Company	MobiWire SAS
Address	107 Boulevard de la Mission Marchand, 92400 Courbevoie, France.
Telephone	+33625028368

3.2 Manufacturer

Company	MobiWire SAS
Address	107 Boulevard de la Mission Marchand, 92400 Courbevoie, France.

4. General Information of The Product

4.1 Product Description for Equipment under Test (EUT)

Product	4G Smart Phone
Model	H5028,Smart Green,Vodafone Lite,Orange Neva sparkle
Date of Receipt	September 4,2022/ September 22,2022
EUT ID*	S01aa/S06aa
SN/IMEI	S01aa: 352243540003670 352243540003688 S06aa: 352243540002615 352243540002623
Supported Radio Technology and Bands	GSM850/GSM900/DCS1800/PCS1900 WCDMA Band I/II/V/VIII LTE Band 1/3/7/20/28 BT5.0 BR/EDR/BLE WLAN 802.11 b/g/n WLAN 802.11 a/n BT5.0 BR/EDR/BLE GPS/GLONASS/Gallileo FM
Hardware Version	V01A
Software Version	Mobiwire_H5028_V01
FCC ID	QPN-H5028
NOTE: EUT ID is the internal identification code of the laboratory.	

4.2 Internal Identification of AE used during the test

AE ID*	Description	Model	SN/Remark
AE1	RF Cable	N/A	N/A
NOTE: AE ID is the internal identification code of the laboratory.			

4.3 Additional Information

WLAN Frequency	2412MHz-2472MHz
Occupied Channel Bandwidth	CH1-13
WLAN type of modulation	802.11b: DSSS 802.11g/n: OFDM

5. Test Configuration Information

5.1 Laboratory Environmental Conditions

5.1.1 Permanent Facilities

Relative Humidity	Min. = 45 %, Max. = 55 %		
Atmospheric Pressure	101kPa		
Temperature	Normal	Minimum	Maximum
	25 °C	-10 °C	55 °C
Working Voltage of EUT	Normal	Minimum	Maximum
	3.8V	3.6V	4.2V

5.2 Test Equipments Utilized

5.2.1 Conducted Test System

No.	Name	Model	S/N	Manufacturer	Cal. Date	Cal. Interval
1	Programmable Power Supply	Keithley 2303	4039070	Starpoint	May 10, 2021	1.5 Years
2	Vector Signal Generator	SMBV100A	257904	R&S	February 21, 2022	1 Year
3	Temperature box	B-TF-107C	BTF107C-201804107	Boyi	May 10, 2021	1.5 Years
4	Spectrum Analyzer	FSQ40	200063	R&S	November 02, 2021	1 Year
5	USB Wideband Power Senser	U2021XA	MY56410009	Keysight	February 21, 2022	1 Year
6	Simultaneous Sampling DQA	U2531A	TW56183514	Agilent	March 02, 2022	1 Year
7	Vector Signal Generator	SMU200A	104684	R&S	May 10, 2021	1.5 Years
8	Wireless communication comprehensive tester	CMW270	100919	R&S	May 10, 2021	1.5 Years
9	Eagle Test Software	Eagle V3.3	N/A	ECIT	N/A	N/A

5.2.2 Radiated Emission Test System

No.	Name	Model	S/N	Manufacturer	Cal. Date	Cal. Interval
1	Universal Radio Communication Tester	CMU200	123123	R&S	2021/5/10	1.5 year
2	Universal Radio Communication Tester	CMW500	104178	R&S	2021/5/10	1.5 year

3	EMI Test Receiver	ESU40	100307	R&S	2022/2/23	1 year
4	TRILOG Broadband Antenna	VULB9163	VULB9163-515	Schwarzbeck	2022/3/11	1 year
5	Double- ridged Waveguide Antenna	ETS-3117	00135890	ETS	2022/3/9	2 years
6	Horn Antenna	3160-09	LM6321	ETS	2021/2/3	3 years
7	Horn Antenna	3160-10	LM5942	ETS	2021/2/3	3 years
8	Pre-amplifier	SCU08F1	8320024	R&S	2021/5/10	1.5 year
9	Pre-amplifier	SCU18	10155	R&S	2021/5/10	1.5 year
10	Pre-amplifier	SCU26	10025	R&S	2021/5/10	1.5 year
11	Pre-amplifier	SCU40	10020	R&S	2021/5/10	1.5 year
12	2-Line V-Network	ENV216	101380	R&S	44613	1 year
13	EMI Test Receiver	ESCI	101235	R&S	44615	1 year
14	EMI Test software	EMC32 V9.15	N/A	R&S	N/A	N/A
15	EMI Test software	EMC32 V10.35.02	N/A	R&S	N/A	N/A

5.2.3 Test Environment

Shielding Room1 (6.0 meters×3.0 meters×2.7 meters) did not exceed following limits along the conducted RF performance testing:

Temperature	Min. = 15 °C, Max. = 35 °C
Relative humidity	Min. = 20 %, Max. = 75 %
Shielding effectiveness	> 100 dB
Ground system resistance	< 0.5 Ω
Temperature	Min. = 15 °C, Max. = 35 °C

Control room did not exceed following limits along the EMC testing:

Temperature	Min. = 15 °C, Max. = 35 °C
Relative humidity	Min. =30 %, Max. = 60 %
Shielding effectiveness	> 100 dB
Electrical insulation	> 10 kΩ
Ground system resistance	< 0.5 Ω

Fully-anechoic chamber1 (9.8 meters×6.7 meters×6.7 meters) did not exceed following limits along the EMC testing:

Temperature	Min. = 15 °C, Max. = 35 °C
Relative humidity	Min. = 25 %, Max. = 75 %
Shielding effectiveness	> 100 dB
Electrical insulation	> 10 kΩ
Ground system resistance	< 0.5 Ω
VSWR	Between 0 and 6 dB, from 1GHz to 18GHz
Site Attenuation Deviation	Between -4 and 4 dB, 30MHz to 1GHz
Uniformity of field strength	Between 0 and 6 dB, from 80MHz to 3000 MHz

5.3 Measurement Uncertainty

Item(s)	Range	Confidence Level	Calculated Uncertainty
Peak Output Power-Conducted	2412MHz-2462MHz	95%	0.544dB
Peak Power Spectral Density	2412MHz-2462MHz	95%	0.502dB
Occupied 6dB Bandwidth	2412MHz-2462MHz	95%	69.26kHz
Band Edges-Conducted	2412MHz-2462MHz	95%	0.544dB
Conducted Emission	9KHz-30MHz	95%	0.89dB
Conducted Emission	30MHz-2GHz	95%	0.90dB
Conducted Emission	2GHz-3.6GHz	95%	0.88dB
Conducted Emission	3.6GHz-8GHz	95%	0.96dB
Conducted Emission	8GHz-20GHz	95%	0.94dB
Conducted Emission	20GHz-22GHz	95%	0.88dB
Conducted Emission	22GHz-26GHz	95%	0.86dB
Transmitter Spurious Emission-Radiated	9KHz-30MHz	95%	5.66dB
Transmitter Spurious Emission-Radiated	30MHz-1000MHz	95%	4.98dB
Transmitter Spurious Emission-Radiated	1000MHz -18000MHz	95%	5.06dB
Transmitter Spurious Emission-Radiated	18000MHz -40000MHz	95%	5.20dB
AC Power line Conducted Emission	0.15MHz-30MHz	95%	3.66 dB

6. Test Results

6.1 Output Power-Conducted

6.1.1. Measurement Limit

Standard	Limit (dBm)
FCC 47 Part 15.247(b)(3)	<30

6.1.2. Test Procedure

The measurement is according to ANSI C63.10 clause 11.9.

1. Set span to at least 1.5 times the OBW.
2. Set RBW = 1-5% of the OBW, not to exceed 1 MHz.
3. Set VBW $\geq 3 \times$ RBW.
4. Number of points in sweep $\geq 2 \times$ span / RBW. (This gives bin-to-bin spacing \leq RBW/2, so that narrowband signals are not lost between frequency bins.)
5. Sweep time = auto.
6. Detector = RMS (i.e., power averaging), if available. Otherwise, use sample detector mode.
7. If transmit duty cycle < 98 %, use a sweep trigger with the level set to enable triggering only on full power pulses. The transmitter shall operate at maximum power control level for the entire duration of every sweep. If the EUT transmits continuously (i.e., with no off intervals) or at duty cycle ≥ 98 %, and if each transmission is entirely at the maximum power control level, then the trigger shall be set to "free run".
8. Trace average at least 100 traces in power averaging (i.e., RMS) mode.i) Compute power by integrating the spectrum across the OBW of the signal using the instrument's band power measurement function, with band limits set equal to the OBW band edges. If the instrument does not have a band power function, sum the spectrum levels (in power units) at intervals equal to the RBW extending across the entire OBW of the spectrum

6.1.3. Test setup

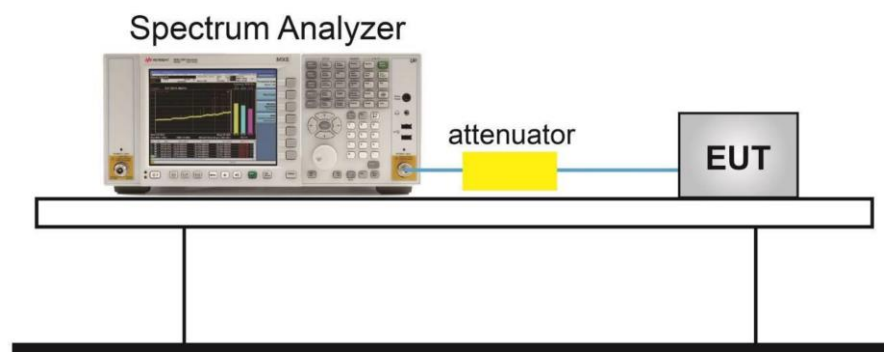

Maximum Average Output Power-conducted

Measurement Results

Mode	Channel	Conducted (dBm)	E.I.R.P(dBm)
802.11b	1	16.24	15.24
	6	15.64	14.64
	11	15.57	14.57
802.11g	1	14.33	13.33
	6	13.88	12.88
	11	14.17	13.17
802.11n(20MHz)	1	12.91	11.91
	6	12.75	11.75
	11	12.73	11.73

Conclusion: PASS

TEST PLOTS:

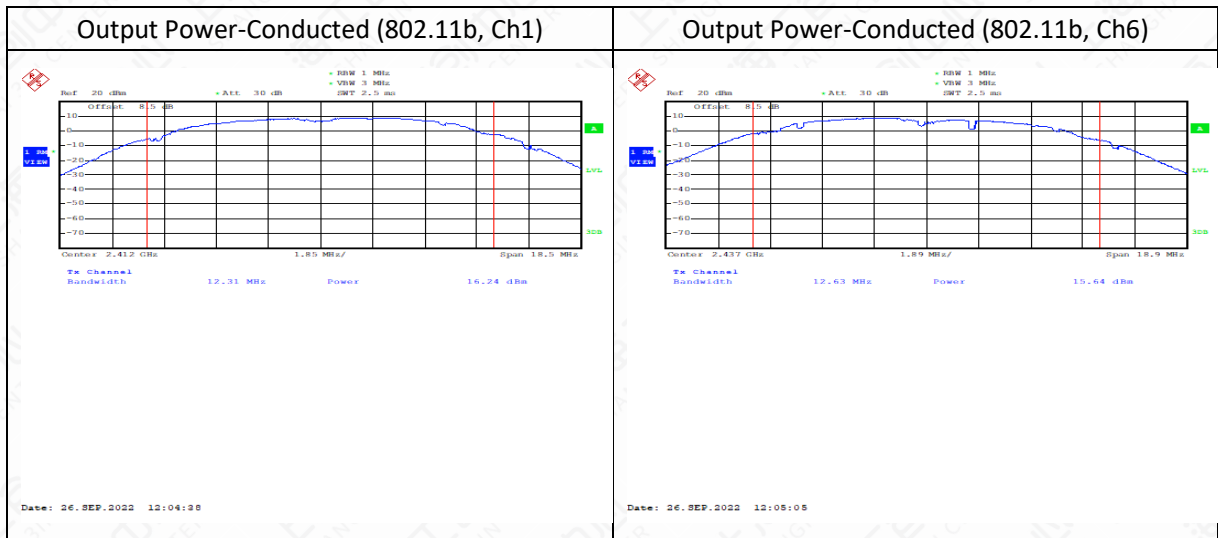



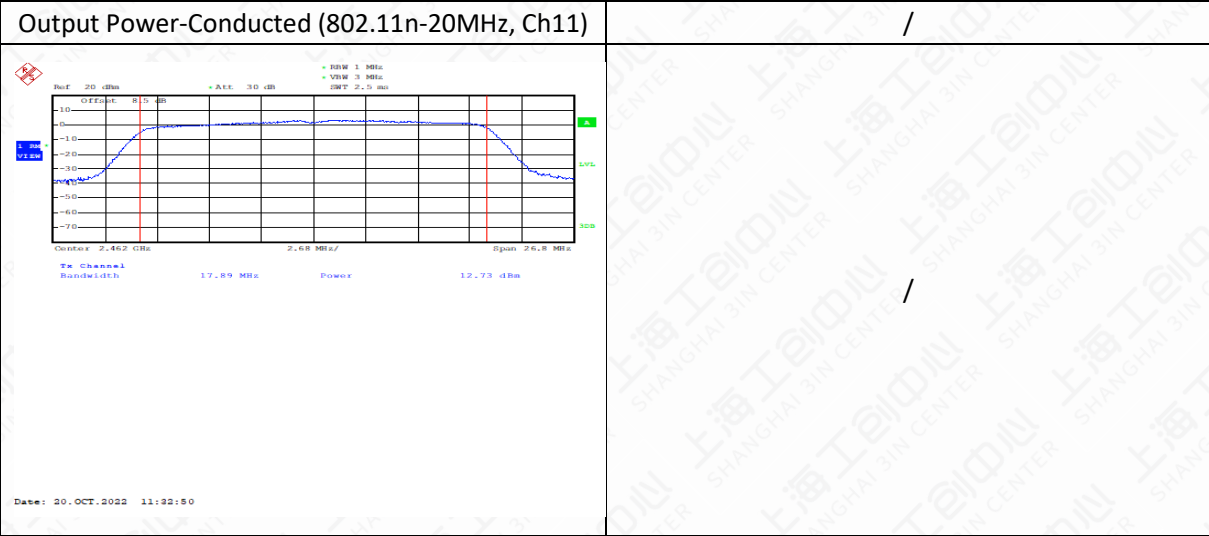

6.2 Peak Power Spectral Density

6.2.1. Measurement Limit

Standard	Limit
FCC 47 Part 15.247(e)	$\leq 8\text{dBm}/3\text{ KHz}$

6.2.2. Test procedures

The measurement is according to ANSI C63.10 clause 11.10.

1. The output power of EUT was connected to the spectrum analyzer. The path loss was compensated to the results for each measurement.
2. Enable EUT transmitter maximum power continuously.
3. Set analyzer center frequency to DTS channel center frequency.
4. Set the span to 1.5 times the DTS bandwidth.
5. Set the RBW=3kHz
6. Set the VBW $\geq [3 \times \text{RBW}]$.
7. Detector = peak.
8. Sweep time = auto couple.
9. Trace mode = max hold.
10. Allow trace to fully stabilize.
11. Use the peak marker function to determine the maximum amplitude level within the RBW.
12. If measured value exceeds requirement, then reduce RBW (but no less than 3 kHz) and repeat

6.2.3. Test setup

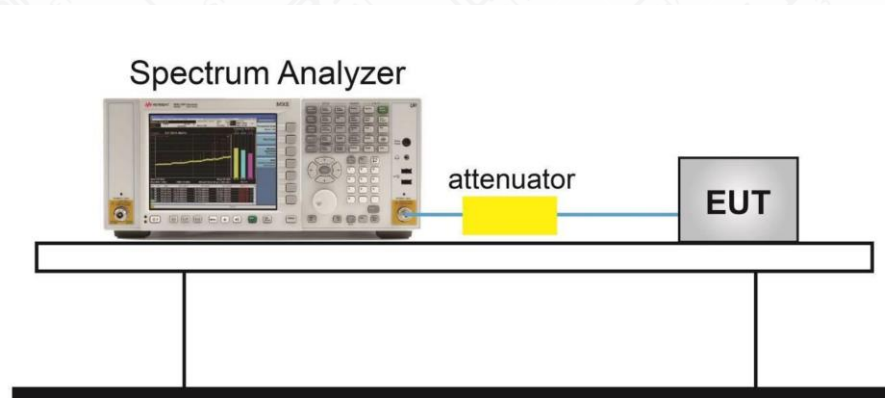

Measurement Result

Modulation type	Frequency (MHz)	PSD (dBm/3kHz)
802.11 b	2412	-15.71
	2437	-16.05
	2462	-16.21
802.11 g	2412	-17.63
	2437	-18.60
	2462	-18.85
802.11 n-20MHz	2412	-20.95
	2437	-20.97
	2462	-20.55

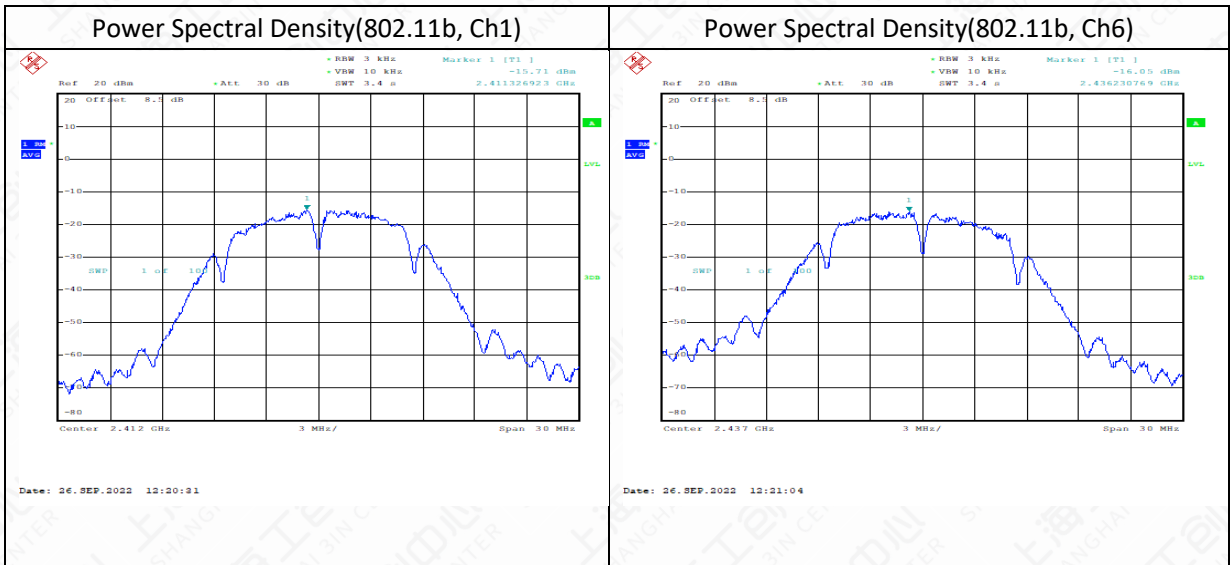

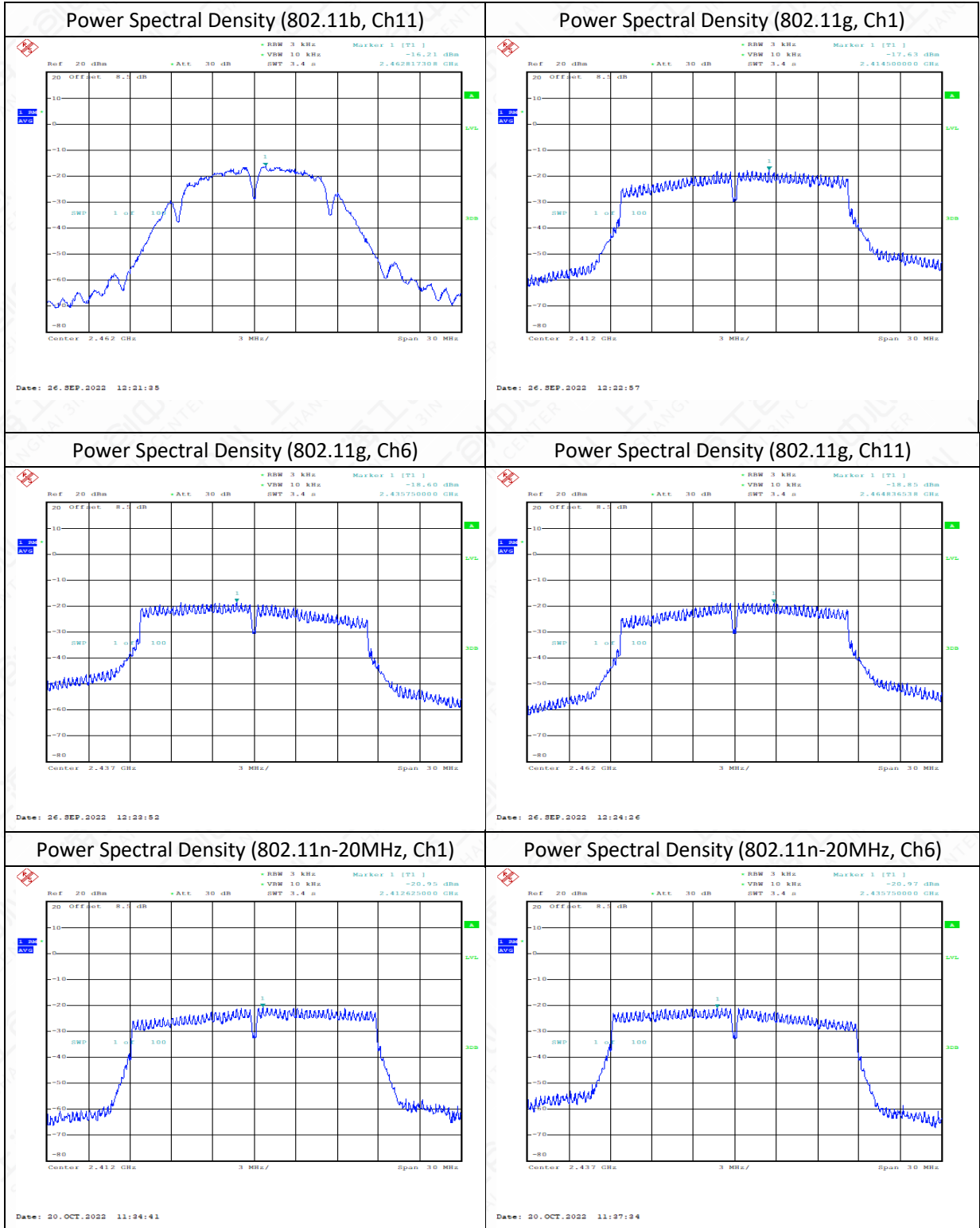

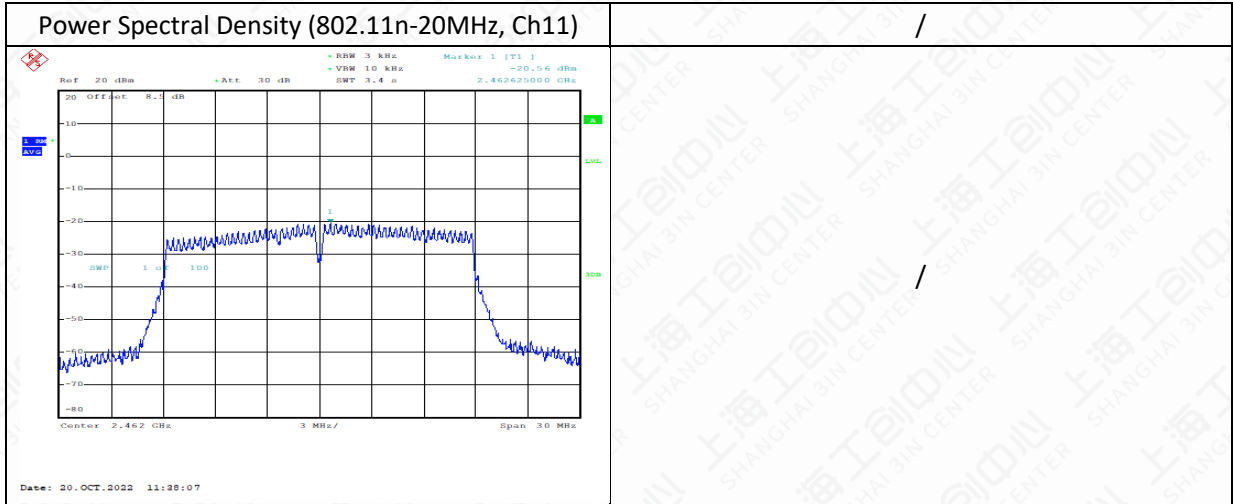

6.3 Occupied 6dB Bandwidth

6.3.1. Measurement Limit

Standard	Limit(KHz)
FCC 47 Part 15.247(a) (2)	≥500KHz

6.3.2. Test procedures

1. The output power of EUT was connected to the spectrum analyzer. The path loss was compensated to the results for each measurement.
2. Enable EUT transmitter maximum power continuously.
3. Set RBW = 100 kHz.
4. Set the VBW ≥ [3 × RBW].
5. Detector = peak.
6. Trace mode = max hold.
7. Sweep = auto couple.
8. Allow the trace to stabilize.
9. Measure the maximum width of the emission that is constrained by the frequencies associated with the two outermost amplitude points (upper and lower frequencies) that are attenuated by 6 dB relative to the maximum level measured in the fundamental emission.

6.3.3. Test Setup

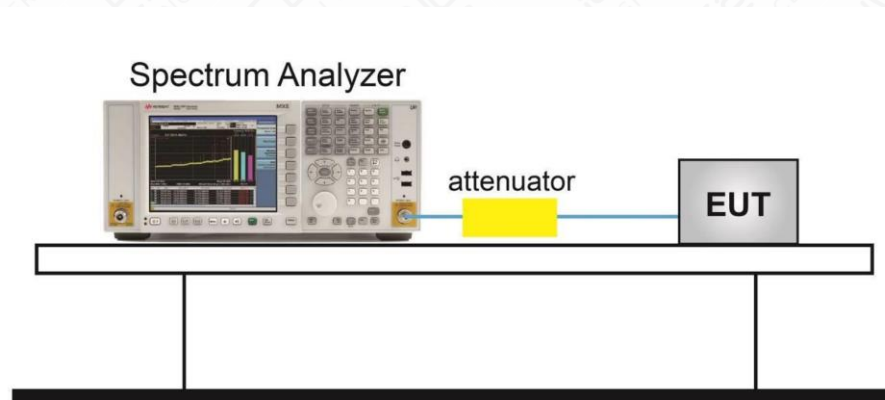

Measurement Results

Mode	Test Result (MHz)		
	2412MHz (Ch1)	2437MHz (Ch6)	2462MHz (Ch11)
802.11b	9.10	9.10	9.49
802.11g	14.42	15.70	15.26
802.11n(20MHz)	16.09	16.35	14.62

Conclusion: PASS

Test graphs as below

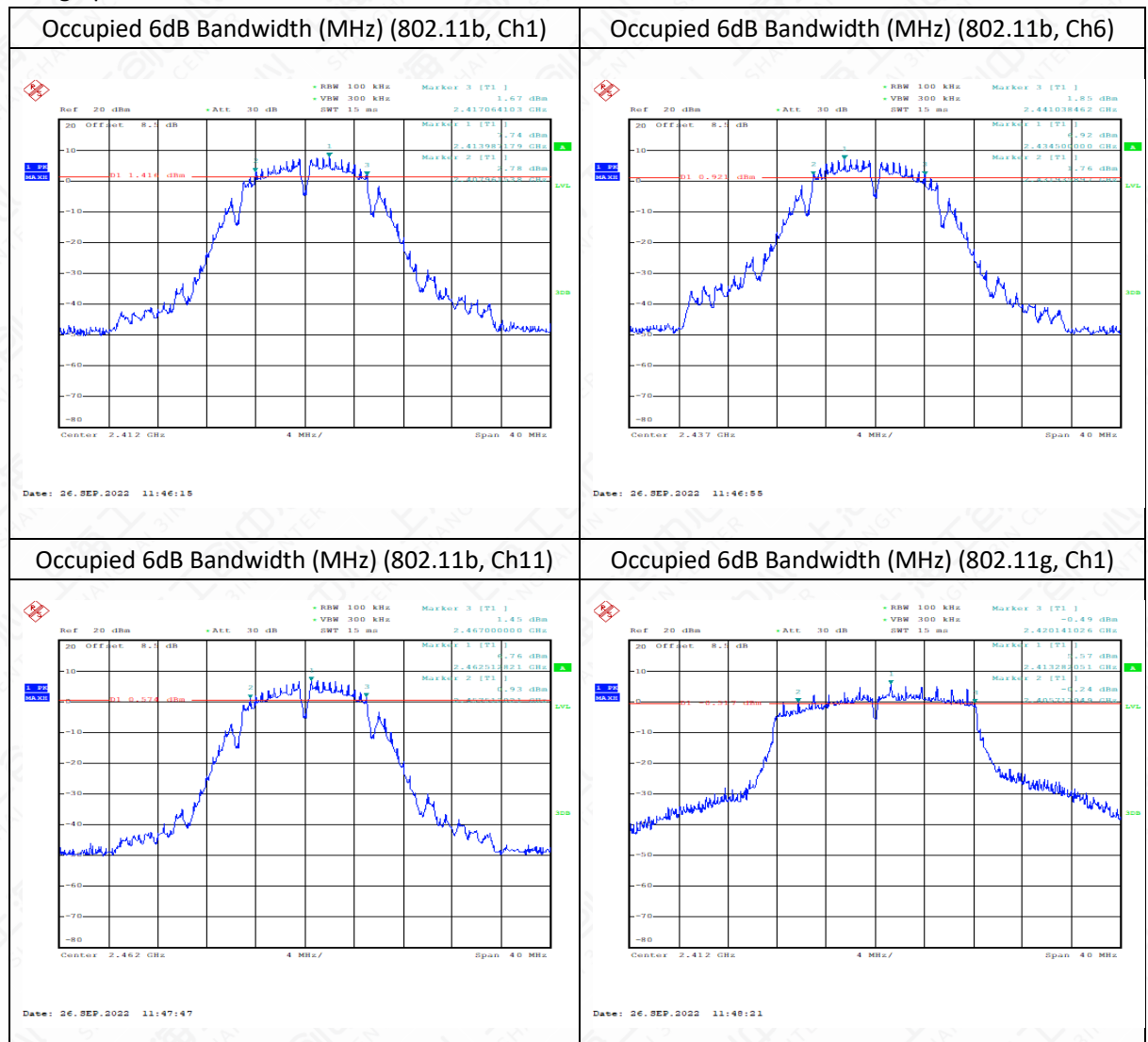

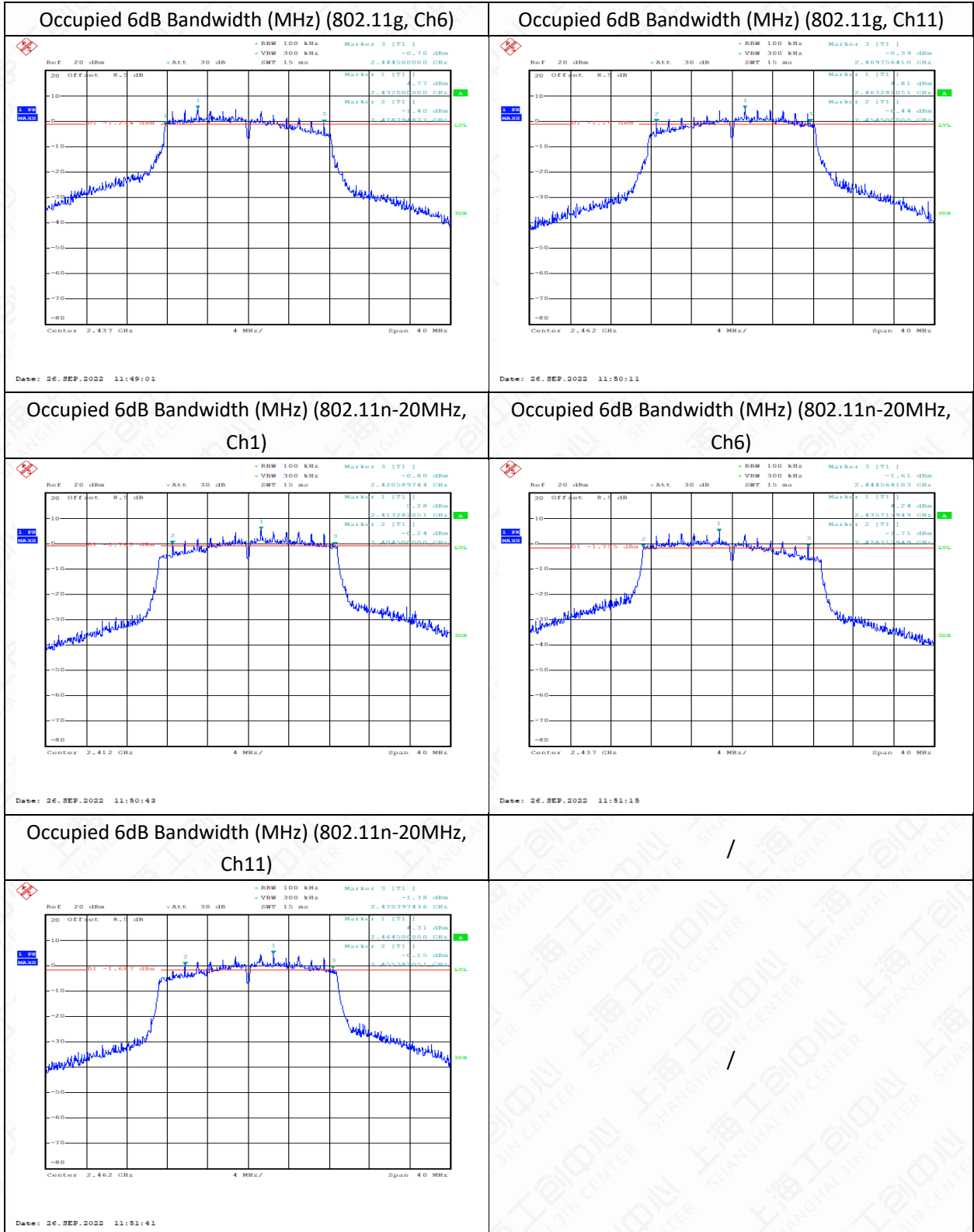

6.4 99% Occupied Bandwidth

6.4.1. Measurement Limit

Standard	Limit
N/A	N/A

6.4.2. Test procedures

The measurement is according to ANSI C63.10 clause 6.9.3.

1. The output power of EUT was connected to the spectrum analyzer. The path loss was compensated to the results for each measurement.
2. Enable EUT transmitter maximum power continuously.
3. Set RBW shall be in the range of 1% to 5% of the OBW.
4. Set the VBW $\geq [3 \times \text{RBW}]$.
5. Detector = peak.
6. Trace mode = max hold.
7. Sweep = auto couple.
8. Allow the trace to stabilize.
9. The occupied bandwidth is the frequency bandwidth such that, below its lower and above its upper frequency limits, the mean powers are each equal to 0.5% of the total mean power of the given emission.

6.4.3. Test setup

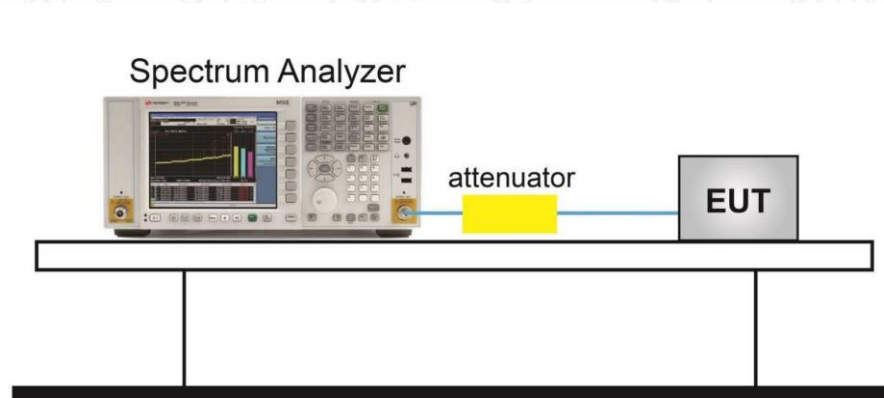

Measurement Result

Mode	Test Result (MHz)		
	2412MHz (Ch1)	2437MHz (Ch6)	2462MHz (Ch11)
802.11b	12.308	12.628	12.372
802.11g	16.859	17.051	16.795
802.11n-20MHz	17.756	17.885	17.692

Conclusion: PASS

Test graphs as below

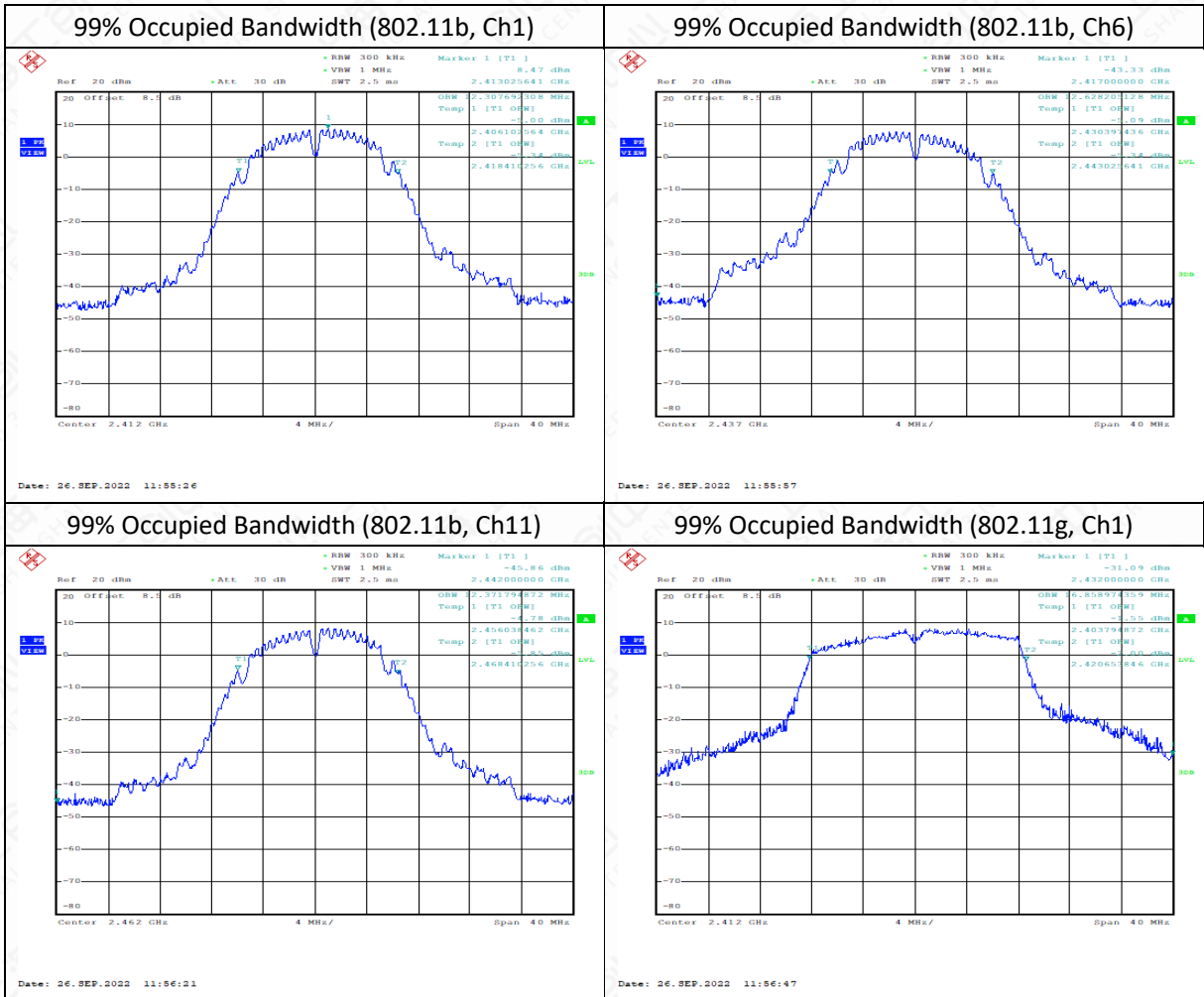

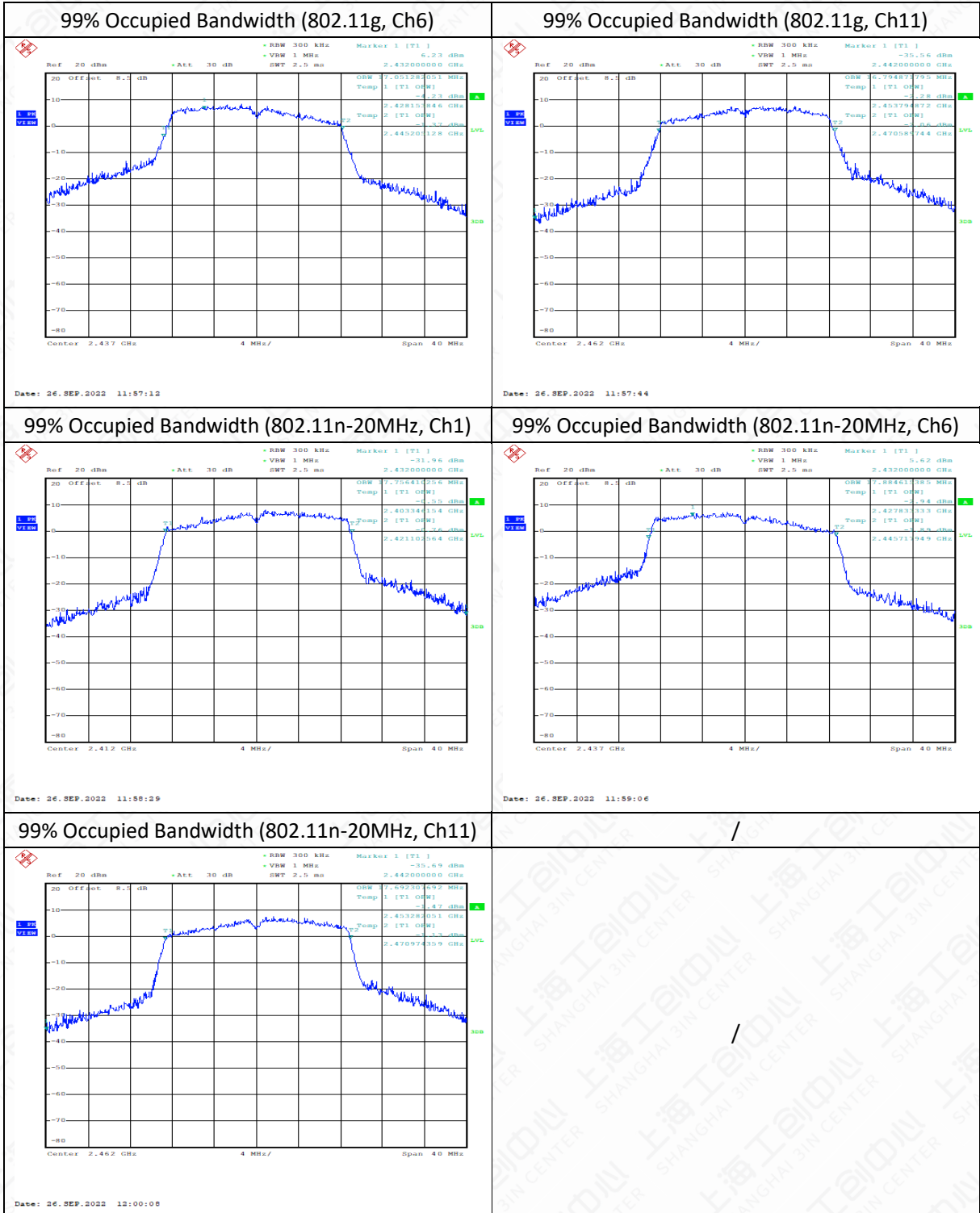

6.5 Band Edges Compliance

6.5.1. Measurement Limit

Standard	Limit(dBc)
FCC 47 Part 15.247(d)	>30

6.5.2. Test procedures

The measurement is according to ANSI C63.10 clause 11.13.

1. The output power of EUT was connected to the spectrum analyzer. The path loss was compensated to the results for each measurement.
2. Enable EUT transmitter maximum power continuously.
3. Set instrument center frequency to the frequency of the emission to be measured (must be within 2MHz of the authorized band edge).
4. Set span to 2 MHz.
5. RBW = 100 kHz.
6. VBW \geq [3 \times RBW].
7. Detector = peak.
8. Sweep time = auto.
9. Trace mode = max hold.
10. Allow sweep to continue until the trace stabilizes

Measurement results

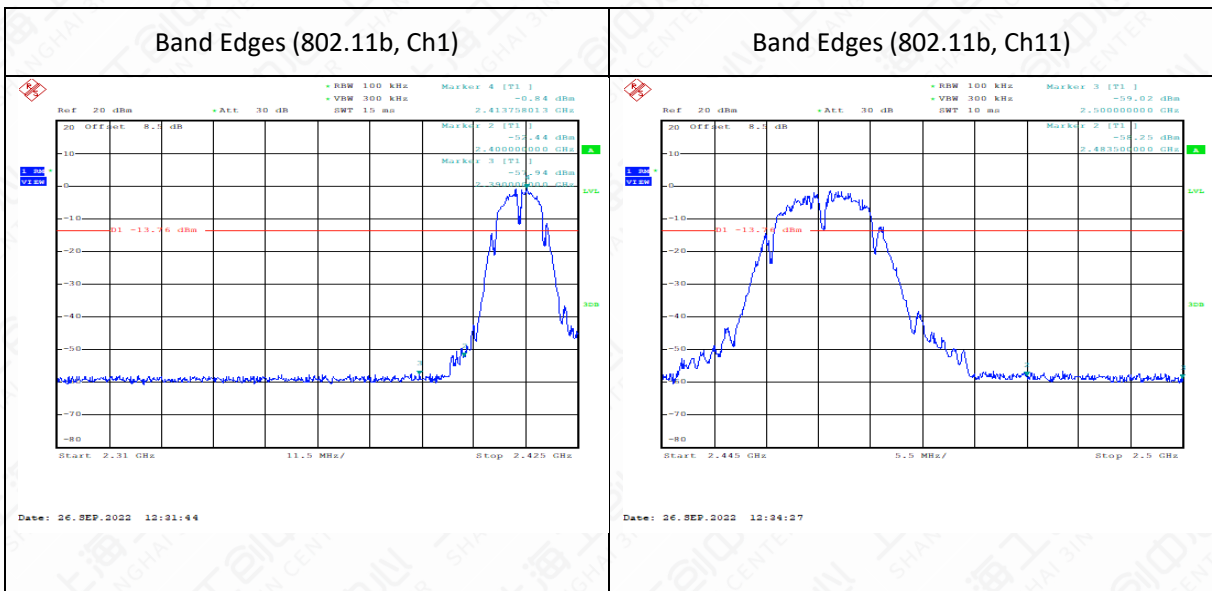

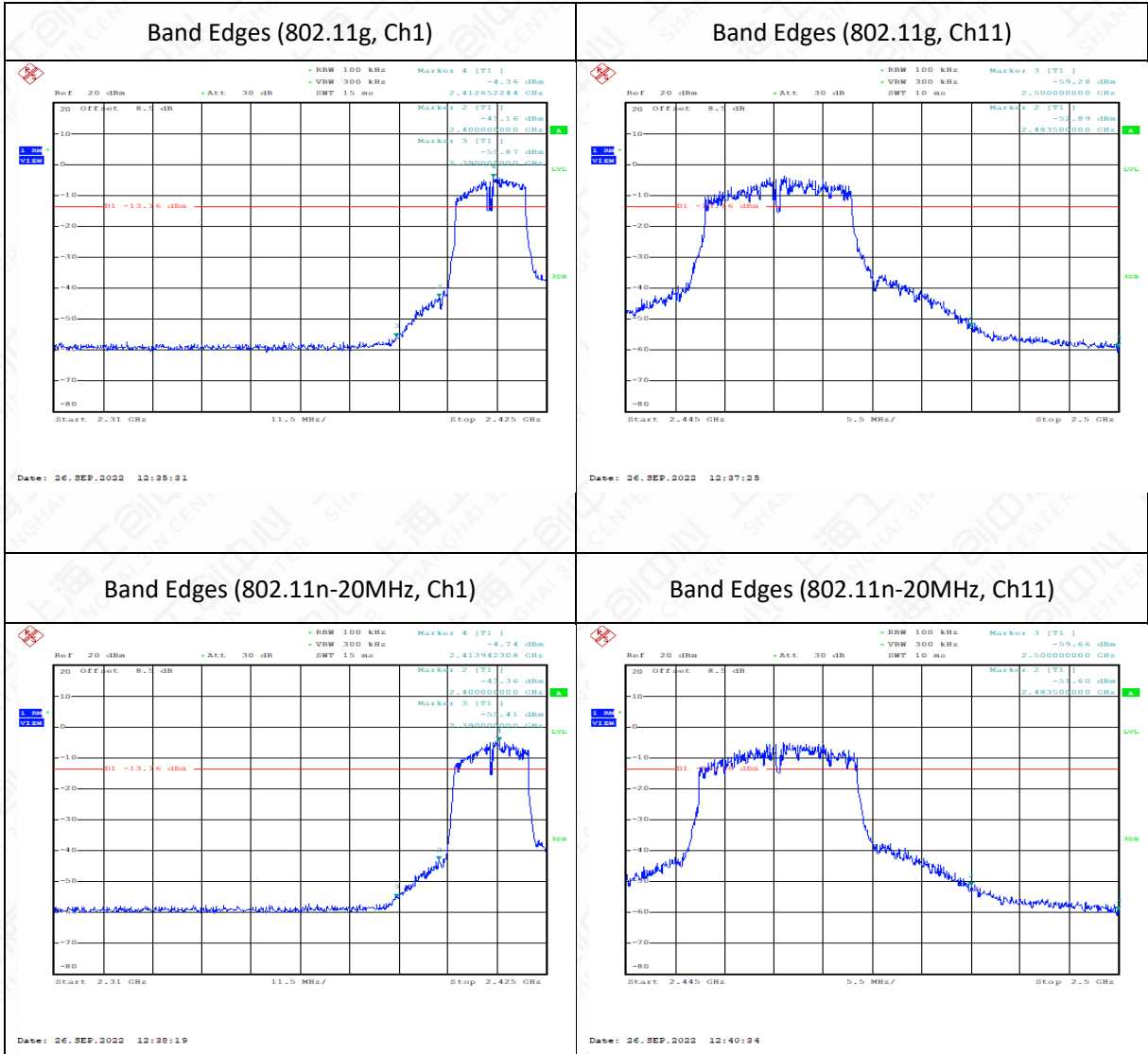

Conclusion: PASS

6.6 Transmitter Spurious Emission-conducted

6.6.1. Measurement Limit

Standard	Limit
FCC 47 Part 15.247(d)	30dB below highest level power in 100KHz bandwidth

6.6.2. Test procedures

This measurement is according to ANSI C63.10 clause 11.11.

1. The output power of EUT was connected to the spectrum analyzer. The path loss was compensated to the results for each measurement.
2. Enable EUT transmitter maximum power continuously.

Reference level measurement

3. Set instrument center frequency to DTS channel center frequency.
4. Set the span to ≥ 1.5 times the DTS bandwidth.
5. Set the RBW = 100 kHz.
6. Set the VBW $\geq [3 \times \text{RBW}]$.
7. Detector = peak.
8. Sweep time = auto couple.
9. Trace mode = max hold.
10. Allow trace to fully stabilize.
11. Use the peak marker function to determine the maximum PSD level.

Emission level measurement

1. Set the center frequency and span to encompass frequency range to be measured.
2. Set the RBW = 100 kHz.
3. Set the VBW $\geq [3 \times \text{RBW}]$.
4. Detector = peak.
5. Sweep time = auto couple.
6. Trace mode = max hold.
7. Allow trace to fully stabilize.
8. Use the peak marker function to determine the maximum amplitude level.

6.6.3. Test Setup

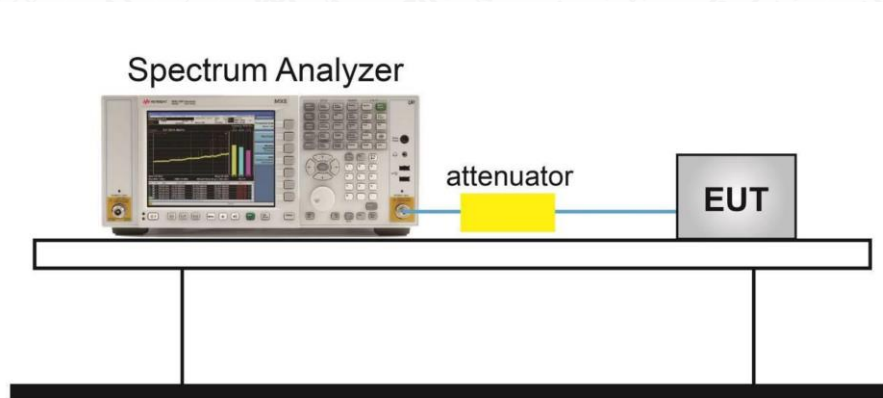

Measurement Result

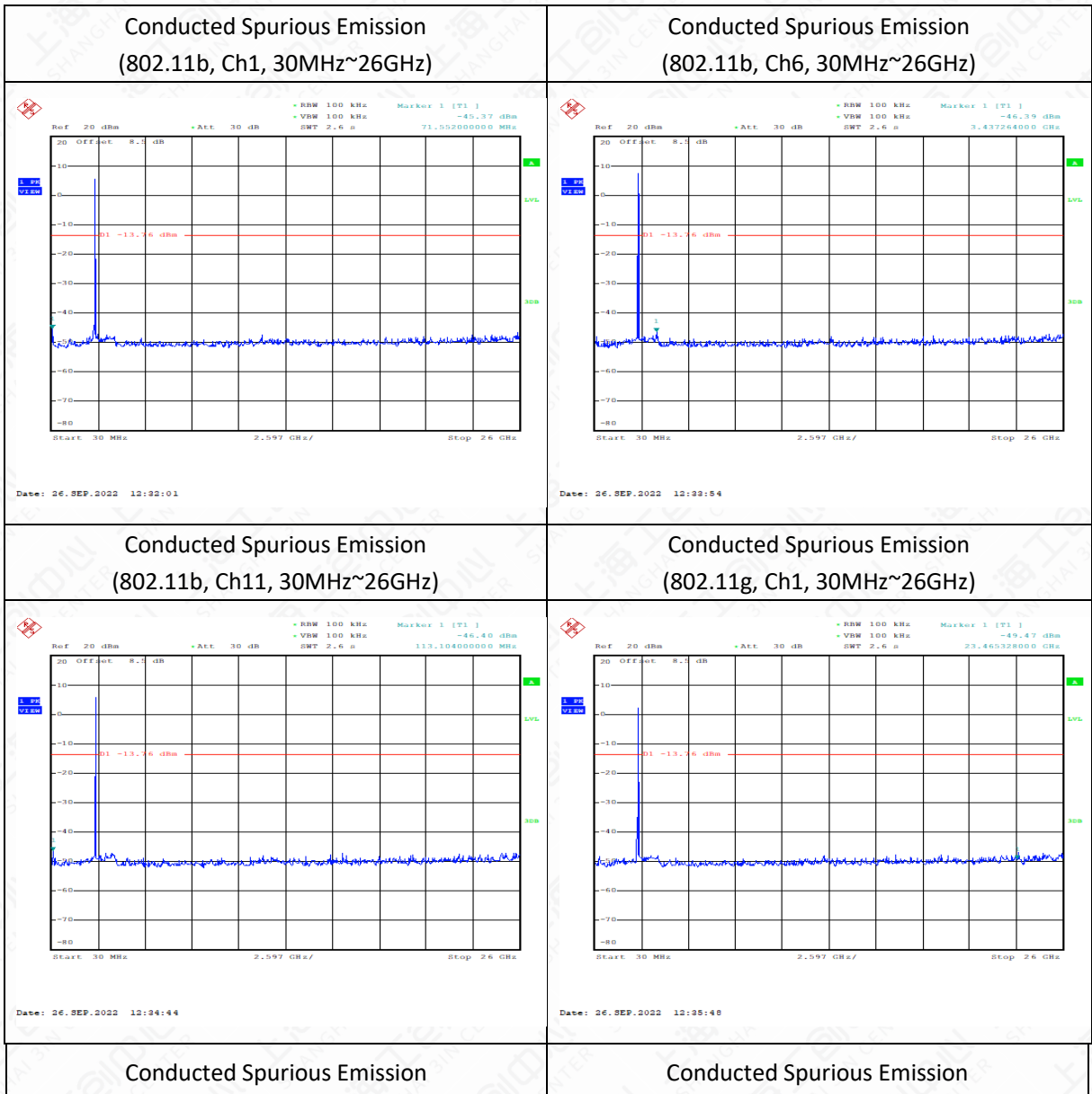

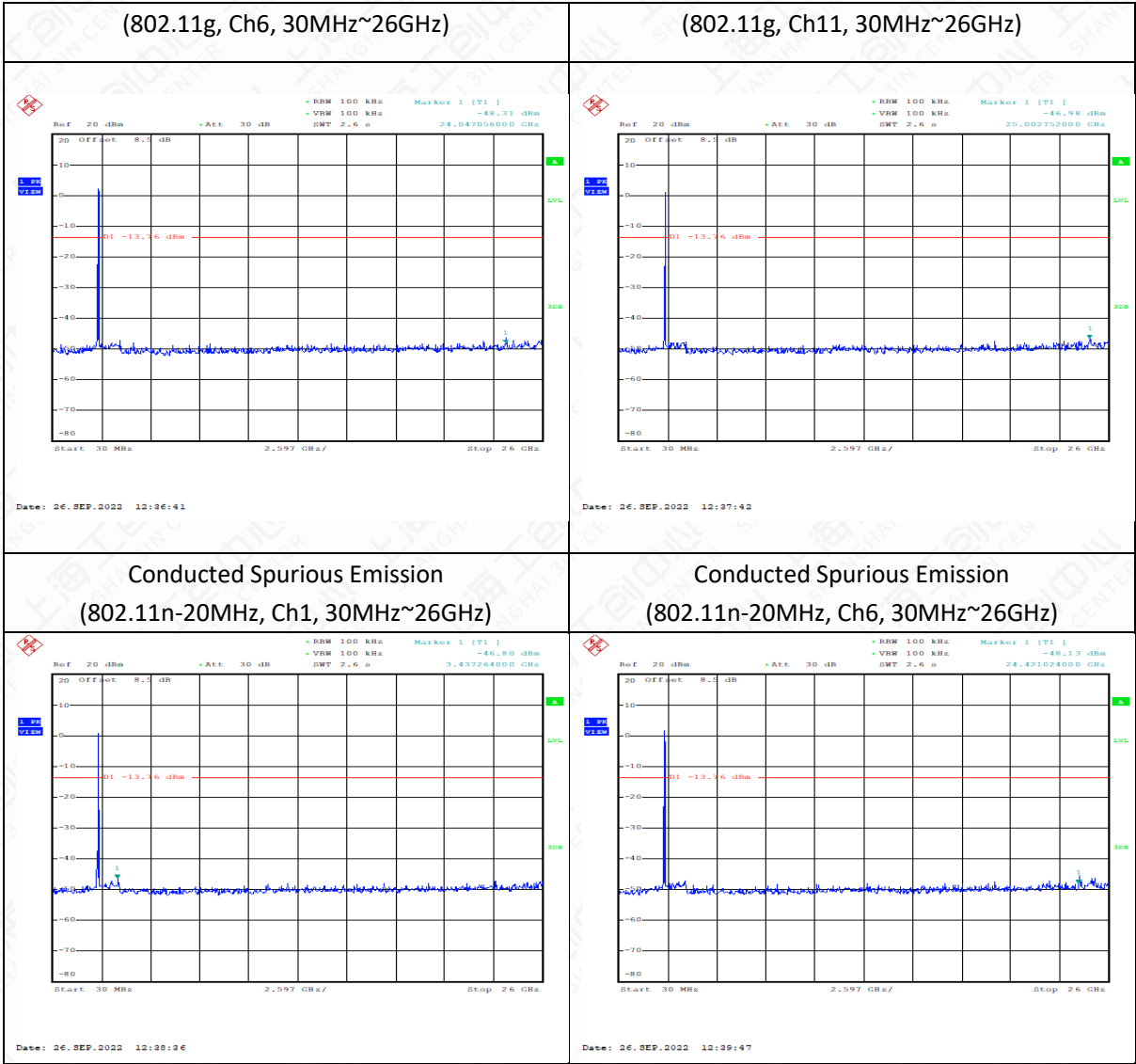

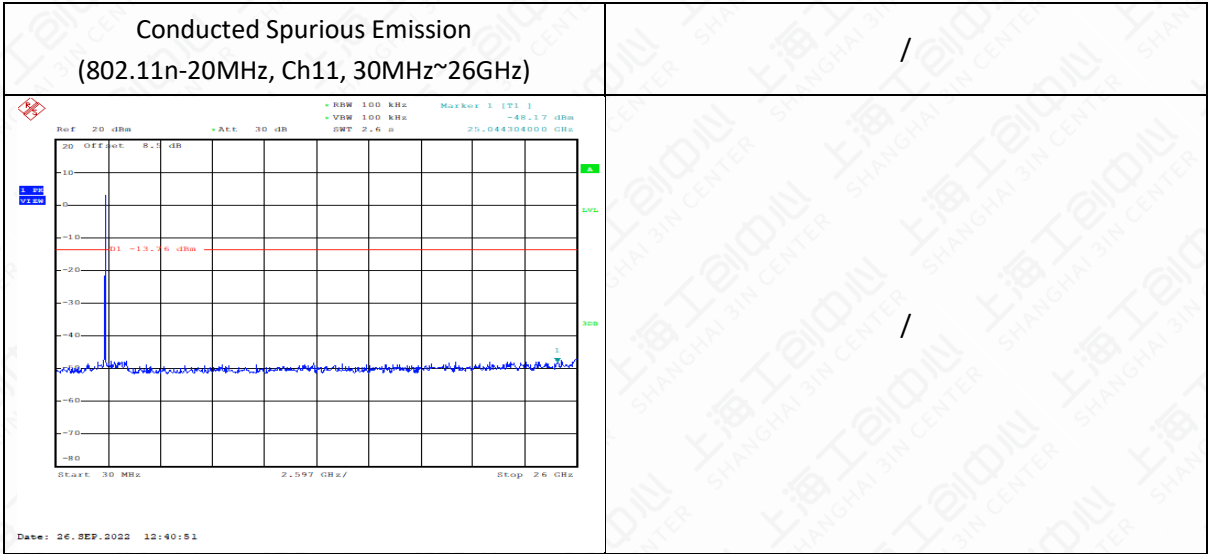

Note: 1. The out-of- limit signal in the picture is the main frequency signal.
 2. The test data below 30MHz is more than 20dB lower than the limit value, so it is not provided in the report.

6.7 Transmitter Spurious Emission-Radiated

6.7.1. Measurement Limit

Standard	Limit
FCC 47 Part 15.247,15.205,15.209	20dB below peak output power

In addition, radiated emissions which fall in the restricted bands, as defined in 25.205(a), must also comply with the radiated emission limits specified in 15.209(a)(see 15.205(c)).

The measurement is according to ANSI C63.10 clause 11.11 and 11.12.

6.7.2. Limit in restricted band

Frequency of emission (MHz)	Field strength(uV/m)	Field strength(dBuV/m)
0.009~0.49	2400/F (kHz)	129-94
0.49~1.705	24000/F (kHz)	74-63
1.705~30	30	70
30~88	100	40
88~216	150	43.5
216~960	200	46
Above 960	500	54

6.7.3. Test procedures

Portable, small, lightweight, or modular devices that may be handheld, worn on the body, or placed on a table during operation shall be positioned on a nonconducting platform, the top of which is 80 cm above the reference ground plane. The preferred area occupied by the EUT arrangement is 1 m by 1.5 m, but it may be larger or smaller to accommodate various sized EUTs. For testing purposes, ceiling- and wall-mounted devices also shall be positioned on a tabletop (see also ANSI C63.4-2013 section 6.3.4 and 6.3.5). In making any tests involving handheld, body-worn, or ceiling-mounted equipment, it is essential to recognize that the measured levels may be dependent on the orientation (attitude) of the three orthogonal axes of the EUT. Thus, exploratory tests as specified in 8.3.1 shall be carried out for various axes orientations to determine the attitude having maximum or near-maximum emission level.

The EUT was placed on a non-conductive table. The measurement antenna was placed at a distance of 3 meters from the EUT. During testing, the antenna height and the EUT azimuth were varied in order to identify the maximum level of emission from the EUT. This maximization process was repeated with the EUT positioned in each of its three orthogonal orientations.

Frequency of emission	RBW/VBW	Sweep Time (s)
0.009~30	9KHz/30KHz	Auto
30~1000	100KHz/300KHz	5
1000~4000	1MHz/3MHz	15
4000~18000	1MHz/3MHz	40
18000~26500	1MHz/3MHz	20

6.7.4. Test Setup

Below 1GHz Test Setup

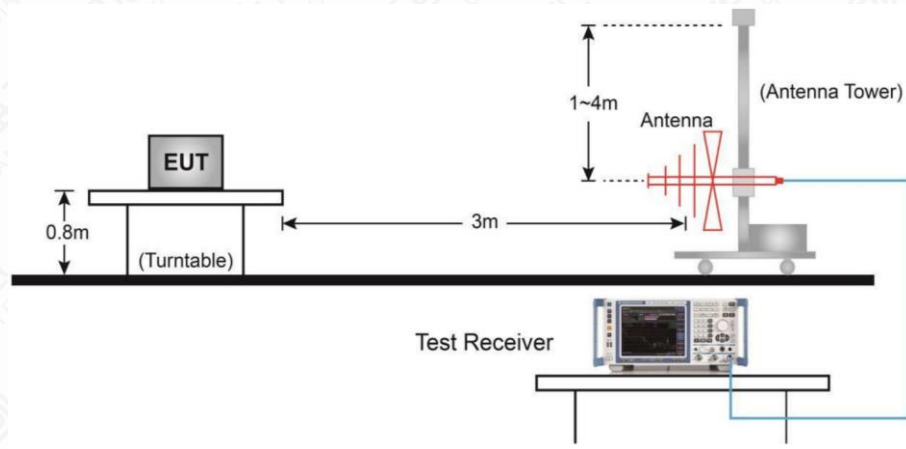

Above 1GHz Test Setup

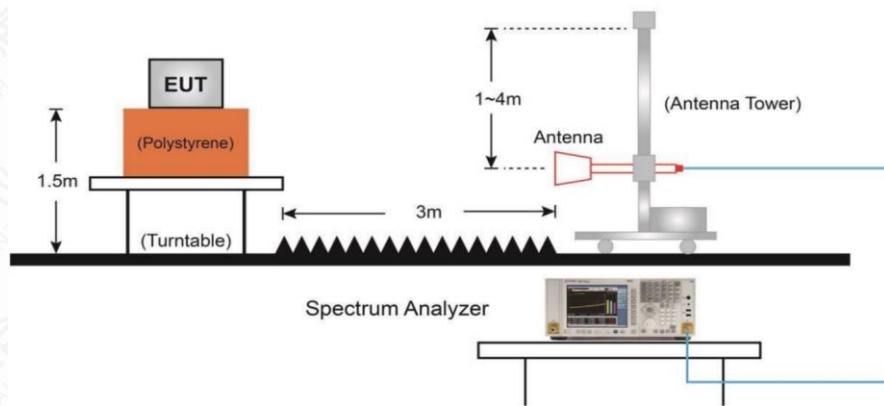

Frequency of emission (MHz)	RBW/VBW	Sweep Times (s)
30~1000	100KHz/300KHz	5
1000~4000	1MHz/3MHz	15
4000~18000	1MHz/3MHz	40
18000~26500	1MHz/3MHz	20

Measurement Results

A "reference path loss" is established and A_{Rpi} is the attenuation of "reference path loss", and including the gain of receive antenna, the gain of the preamplifier, the cable loss.

P_{Mea} is the field strength recorded from the instrument.

The measurement results are obtained as described below:

$$A_{Rpi} = \text{Cable loss} + \text{Antenna Factor} - \text{Preamplifier gain}$$

$$\text{Result} = P_{Mea} + \text{Cable loss} + \text{Antenna Factor} - \text{Preamplifier gain} = P_{Mea} + A_{Rpi}$$

The test data below 30MHz is more than 20dB lower than the limit value, so it is not provided in the report.

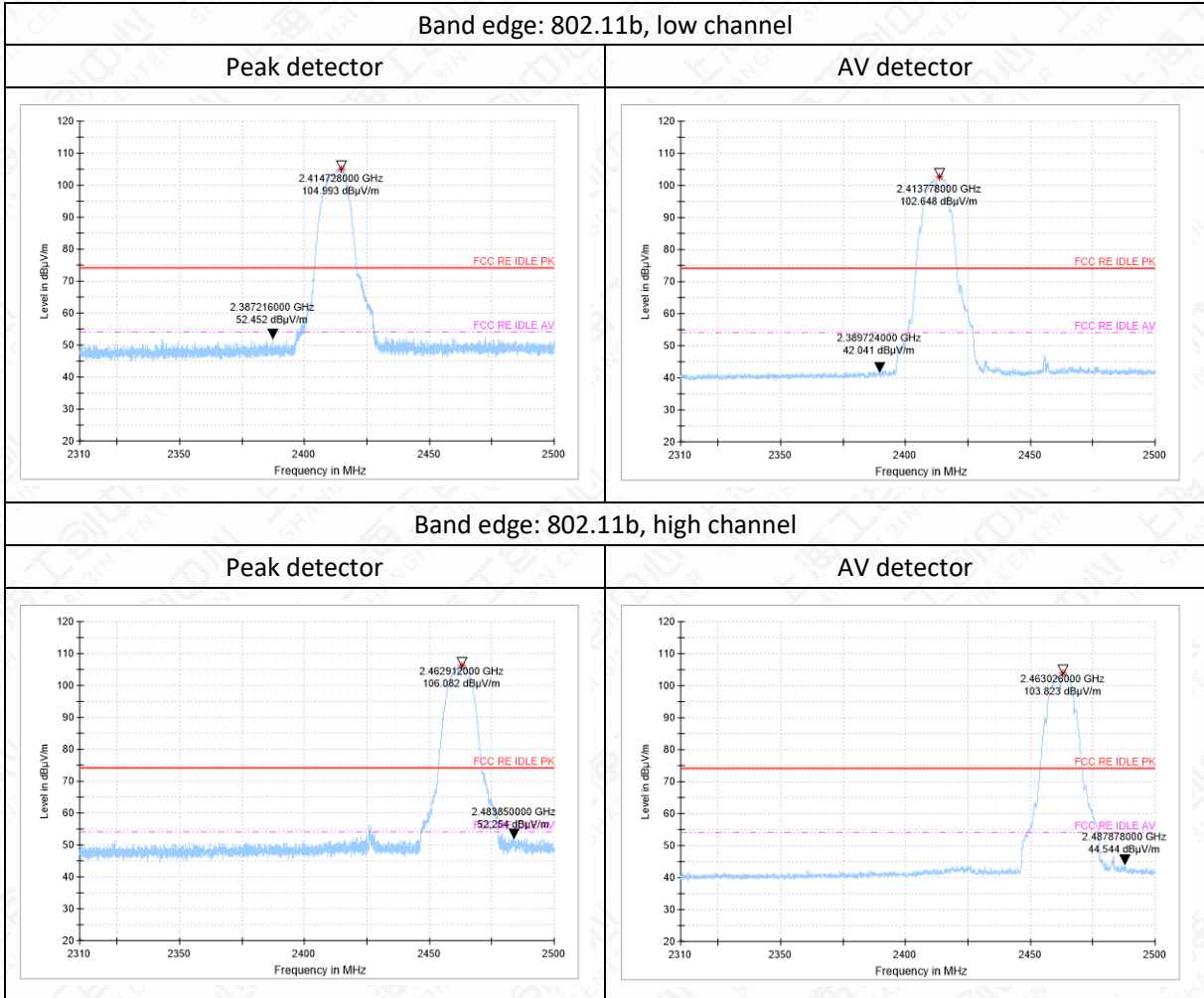

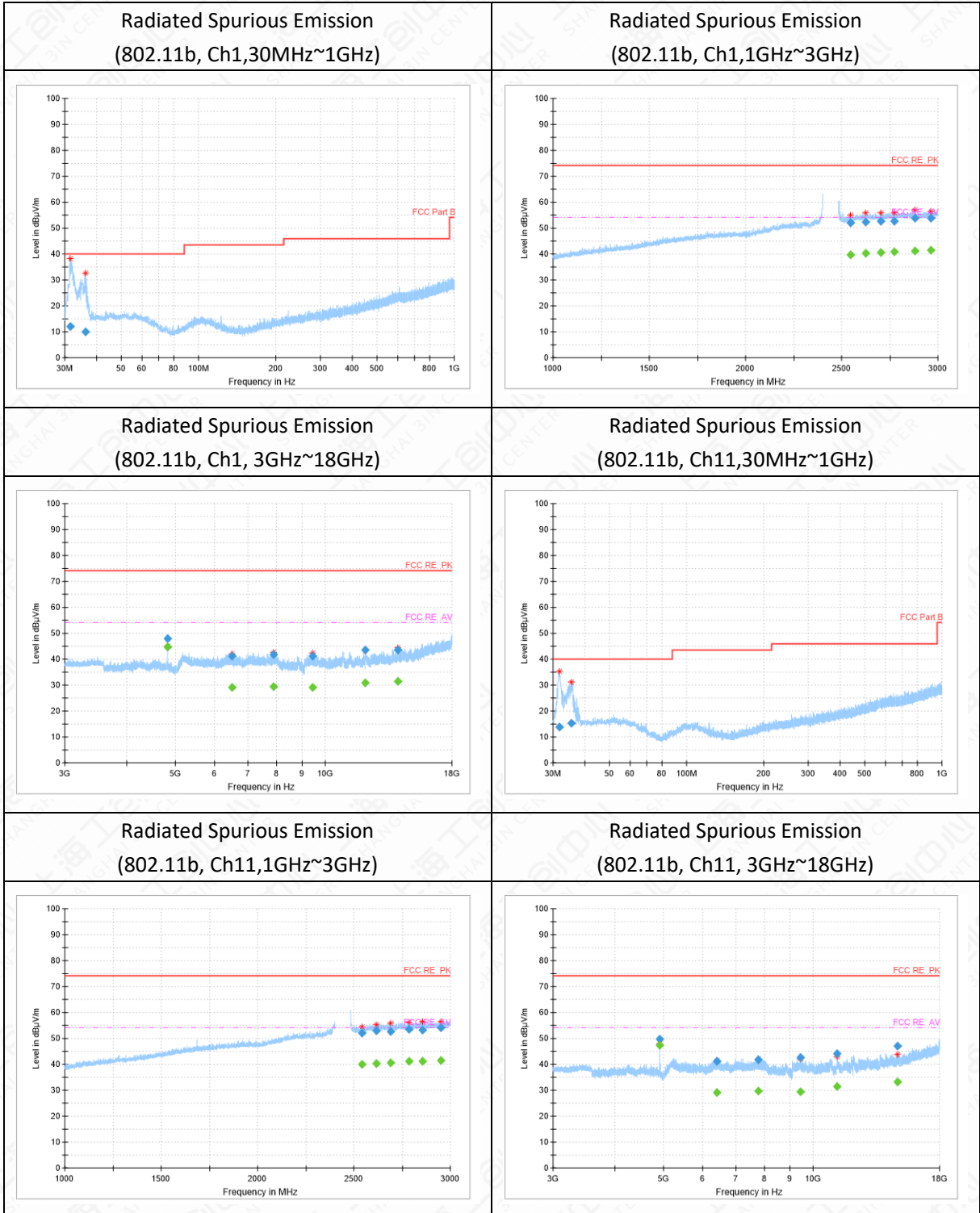

Note: The out-of- limit signal in the picture is the main frequency signal.

802.11b

Ch1 30MHz~1GHz

Frequency (MHz)	Result (dBμV/m)	ARpl (dB)	PMea (dBμV/m)	Polarity
31.6	12.2	-14.3	26.5	V
36.1	9.91	-13.8	23.71	V

Ch1 1GHz~3GHz

Frequency (MHz)	Result (dB μ V/m)	ARpl (dB)	PMea (dB μ V/m)	Polarity
2544.9	52.02	15	37.02	V
2624.7	52.28	15.7	36.58	V
2703.2	52.58	15.9	36.68	V
2771.2	52.62	16.4	36.22	V
2880.4	53.7	16.7	37	V
2964.6	53.82	17	36.82	H

Ch1 3GHz~18GHz

Frequency (MHz)	Result (dB μ V/m)	ARpl (dB)	PMea (dB μ V/m)	Polarity
4823.9	47.95	-4.8	52.75	H
6506.5	41.09	-2.6	43.69	H
7873.9	41.78	-1.7	43.48	H
9458.5	41.04	-0.3	41.34	H
12055.2	43.6	2	41.6	V
14001.7	43.62	4.7	38.92	H

Ch11 30MHz~1GHz

Frequency (MHz)	Result (dB μ V/m)	ARpl (dB)	PMea (dB μ V/m)	Polarity
31.8	13.95	-14.3	28.25	V
35.4	15.3	-13.9	29.2	V

Ch11 1GHz~3GHz

Frequency (MHz)	Result (dB μ V/m)	ARpl (dB)	PMea (dB μ V/m)	Polarity
2539.5	52.13	14.9	37.23	H
2615.6	53.06	15.6	37.46	V
2690.7	52.59	15.9	36.69	V
2784.7	53.59	16.5	37.09	H
2856.8	53.35	16.7	36.65	H
2952.3	54.21	16.8	37.41	V

Ch11 1GHz~3GHz(Average)

Frequency (MHz)	Result (dB μ V/m)	ARpl (dB)	PMea (dB μ V/m)	Polarity
2952.3	41.46	16.8	24.66	V

Ch11 3GHz~18GHz

Frequency (MHz)	Result (dB μ V/m)	ARpl (dB)	PMea (dB μ V/m)	Polarity
4923.9	49.81	-4.5	54.31	H
6421.7	41.14	-2.6	43.74	V
7764.8	41.87	-1.8	43.67	V
9433.9	42.61	-0.2	42.81	H
11200.6	44.22	1.7	42.52	H
14803.8	47.02	5.7	41.32	V

6.8 AC Powerline Conducted Emission

6.8.1. Method of Measurement: ANSI C63.10-2013-clause 6.2

1. The one EUT cable configuration and arrangement and mode of operation that produced the emission with the highest amplitude relative to the limit is selected for the final measurement, while applying the appropriate modulating signal to the EUT.
2. If the EUT is relocated from an exploratory test site to a final test site, the highest emissions shall be remaximized at the final test location before final ac power-line conducted emission measurements are performed.
3. The final test on all current-carrying conductors of all of the power cords to the equipment that comprises the EUT (but not the cords associated with other non-EUT equipment in the system) is then performed for the full frequency range for which the EUT is being tested for compliance without further variation of the EUT arrangement, cable positions, or EUT mode of operation.
4. If the EUT is comprised of equipment units that have their own separate ac power connections, e.g., floor-standing equipment with independent power cords for each shelf that are able to connect directly to the ac power network, each current-carrying conductor of one unit is measured while the other units are connected to a second (or more) LISN(s). All units shall be separately measured. If a power strip is provided by the manufacturer, to supply all of the units making up the EUT, only the conductors in the power cord of the power strip shall be measured.

If the EUT uses a detachable antenna, these measurements shall be made with a suitable dummy load connected to the antenna output terminals; otherwise, the tests shall be made with the antenna connected and, if adjustable, fully extended. When measuring the ac conducted emissions from a device that operates between 150 kHz and 30 MHz a non-detachable antenna may be replaced with a dummy load for the measurements within the fundamental emission band of the transmitter, but only for those measurements.³⁶ Record the six highest EUT emissions relative to the limit of each of the current-carrying conductors of the power cords of the equipment that comprises the EUT over the frequency range specified by the procuring or regulatory agency. Diagram or photograph the test setup that was used. See Clause 8 for full reporting requirements.

6.8.2. Test Setup

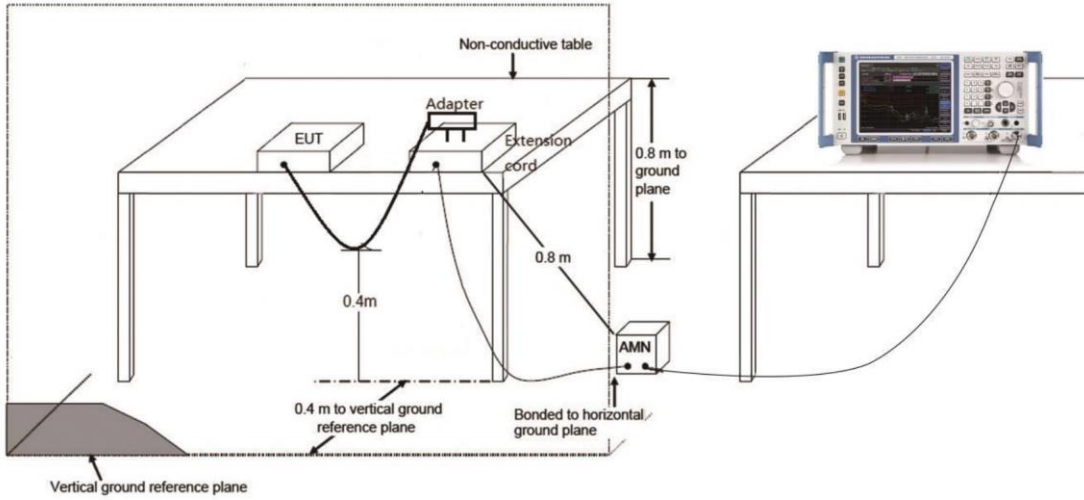

6.8.3. Test Condition

Voltage (V)	Frequency (Hz)
120	60

Measurement Result and limit:
(Quasi-peak-average Limit)

Frequency range (MHz)	Quasi-peak Limit (dBμV)	Average Limit (dBμV)	Conclusion
0.15 to 0.5	66 to 56	56 to 46	P
0.5 to 5	56	46	
5 to 30	60	50	

NOTE: The limit decreases linearly with the logarithm of the frequency in the range 0.15 MHz to 0.5 MHz.

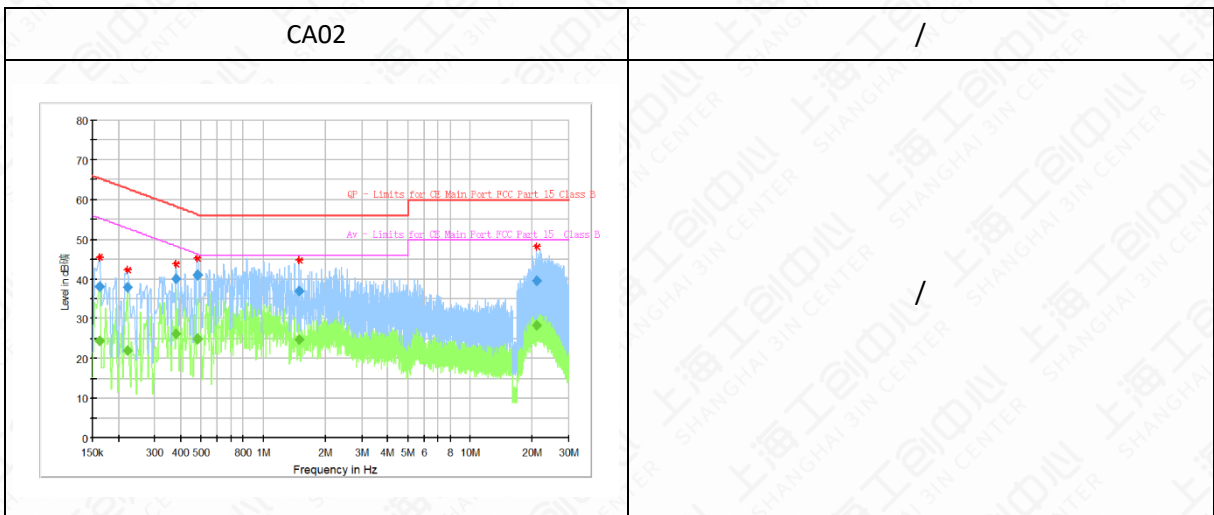

Frequency (MHz)	QuasiPeak (dBμV)	Average (dBμV)	Limit (dBμV)	Margin (dB)	Meas. Time (ms)	Bandwidth (kHz)	Line	Filter	Corr. (dB)
0.161194	---	24.38	55.40	31.03	15000.0	9.000	L1	ON	9.6
0.161194	38.17	---	65.40	27.23	15000.0	9.000	L1	ON	9.6
0.220894	---	22.04	52.79	30.74	15000.0	9.000	L1	ON	9.6
0.220894	37.99	---	62.79	24.79	15000.0	9.000	L1	ON	9.6
0.381338	---	26.12	48.25	22.13	15000.0	9.000	N	ON	8.4
0.381338	40.02	---	58.25	18.24	15000.0	9.000	N	ON	8.4
0.482081	---	25.06	46.30	21.25	15000.0	9.000	N	ON	9.5
0.482081	41.08	---	56.30	15.22	15000.0	9.000	N	ON	9.5
1.485788	---	24.63	46.00	21.37	15000.0	9.000	N	ON	9.7
1.485788	36.86	---	56.00	19.14	15000.0	9.000	N	ON	9.7
21.045000	---	28.32	50.00	21.68	15000.0	9.000	N	ON	10.2
21.045000	39.70	---	60.00	20.30	15000.0	9.000	N	ON	10.2

Annex A: Revised History

Version	Revised Content
V00	Initial

Annex B: Accreditation Certificate



Accredited Laboratory

A2LA has accredited

**INDUSTRIAL INTERNET INNOVATION CENTER
(SHANGHAI) CO., LTD.**
Shanghai, People's Republic of China

for technical competence in the field of

Electrical Testing

This laboratory is accredited in accordance with the recognized International Standard ISO/IEC 17025:2017 *General requirements for the competence of testing and calibration laboratories*. This accreditation demonstrates technical competence for a defined scope and the operation of a laboratory quality management system (refer to joint ISO-ILAC-IAF Communiqué dated April 2017).



Presented this 12th day of April 2021.



Vice President, Accreditation Services
For the Accreditation Council
Certificate Number 3682.01
Valid to February 28, 2023

For the tests to which this accreditation applies, please refer to the laboratory's Electrical Scope of Accreditation.

END OF REPORT