



# TEST REPORT

No. I14D00071-EMC

*For*

**Client : Mobewire SAS**

**Production: Connected mobile with Printer**

**Model Name : MOBIPRINT<sup>3</sup>**

**Hardware Version: V02**

**Software Version: V03**

**FCC ID: QPN-3G-MOBIPRINT3**

**Issued date: 2015-03-04**

**Note:**

The test results in this test report relate only to the devices specified in this report. This report shall not be reproduced except in full without the written approval of ECIT Shanghai.

**Test Laboratory:**

ECIT Shanghai, East China Institute of Telecommunications

Add: 7F, G Area, No.668, Beijing East Road, Huangpu District, Shanghai, P. R. China

Tel: (+86)-021-63843300, E-Mail: [welcome@ecit.org.cn](mailto:welcome@ecit.org.cn)

## Revision Version

Report Number	Revision	Date	Memo
I14D00071-EMC	00	2015-03-04	Initial creation of test report

## CONTENTS

1. TEST LABORATORY .....	4
1.1. TESTING LOCATION .....	4
1.2. TESTING ENVIRONMENT .....	4
1.3. PROJECT DATA .....	4
1.4. SIGNATURE .....	4
2. CLIENT INFORMATION .....	5
2.1. APPLICANT INFORMATION .....	5
2.2. MANUFACTURER INFORMATION .....	5
3. EQUIPMENT UNDER TEST (EUT) AND ANCILLARY EQUIPMENT (AE) .....	6
3.1. ABOUT EUT .....	6
3.2. INTERNAL IDENTIFICATION OF AE USED DURING THE TEST .....	6
4. REFERENCE DOCUMENTS.....	7
4.1. REFERENCE DOCUMENTS FOR TESTING .....	7
5. TEST RESULTS.....	8
5.1. SUMMARY OF TEST RESULTS.....	8
5.2. STATEMENTS.....	8
6. TEST EQUIPMENTS UTILIZED.....	9
6.1 RADIATED EMISSION EQUIPMENTS LIST .....	9
6.1 CE EQUIPMENTS LIST.....	9
7. SYSTEM CONFIGURATION DURING TEST .....	10
7.1 TEST MODE.....	10
7.2 CONNECTION DIAGRAM OF TEST SYSTEM.....	10
8. MEASUREMENT RESULTS .....	11
8.1 RADIATED EMISSION 30MHZ-12.75GHZ .....	11
8.2 CONDUCTED EMISSION.....	15

## 1. Test Laboratory

### 1.1. Testing Location

Company Name:	ECIT Shanghai, East China Institute of Telecommunications
Address:	7-8F, G Area, No. 668, Beijing East Road, Huangpu District, Shanghai, P. R. China
Postal Code:	200001
Telephone:	(+86)-021-63843300
Fax:	(+86)-021-63843301
FCC Registration NO.:	489729

### 1.2. Testing Environment

Normal Temperature:	15-35°C
Relative Humidity:	30-60%

### 1.3. Project data

Project Leader:	Gong Yujuan
Testing Start Date:	2015-02-01
Testing End Date:	2015-02-17

### 1.4. Signature

  
You Jinjun  
(Prepared this test report)

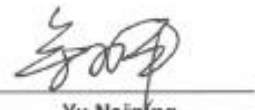
  
Yu Naiping  
(Reviewed this test report)

  
Zheng Zhongbin  
Director of the laboratory  
(Approved this test report)

## 2. Client Information

### 2.1. Applicant Information

Company Name: Mobewire SAS.  
Address: 79 AVENUE FRANCOIS ARAGO 92017 NANTERRE CEDEX  
France.  
Telephone: 33613423487  
Postcode: 92017

### 2.2. Manufacturer Information

Company Name: MOBIWIRE MOBILES (NINGBO) CO.,LTD  
Address: No.999,Dacheng East Road,Fenghua City,Zhejiang  
Telephone: 0574 88916450  
Postcode: 315500

### 3. Equipment under Test (EUT) and Ancillary Equipment (AE)

#### 3.1. About EUT

EUT Description	Connected mobile POS with Printer
Model name	MOBIPRINT <sup>3</sup>
Serial Number or IMEI	353007060004569/353007060004577
Frequency Band	GSM900/1800/850/1900 WCDMA 850/1900/2100
HW Version	V02
SW Version	V03

#### 3.2. Internal Identification of AE used during the test

AE ID*	Description	Model	SN
AE1	Adapter	A31-3762-501000	NA
AE2	Battery	H15287	EB09F000000E0000375T
AE3	Earphone	NA	NA
AE4	Data Cable	NA	NA
AE5	Desktop PC	OptiPlex 790 DT	X8RP1 A01 APCC
AE6	Notebook PC	ThinkPad Edge E430	0B65911
AE7	LAN Cable	NA	NA
AE8	VGA Cable	NA	NA
AE9	RS232 Cable	NA	NA
AE10	Keyboard	KB212-B	CN-0Y88XT-65890-12I-005Q-A00
AE11	Mouse	MS111-P	CN-011D3V-71581-19J-1A64

\*AE ID: is used to identify the test sample in the lab internally.

## 4. Reference Documents

### 4.1. Reference Documents for testing

The following documents listed in this section are referred for testing.

Reference	Title	Version
FCC Part 15, Subpart B	Radio frequency devices	10-1-10 Edition
ANSI C63.4	Method of Measurement of Radio-Noise Emissions from Low-Voltage Electrical and Electronic Equipment in the Range of 9 kHz to 40 GHz	2009

## 5. Test Results

### 5.1. Summary of Test Results

Items	Test List	Clause in FCC rules	Verdict
1	Radiated Emission	15.109(a)	Pass
2	Conducted Emission	15.107(a)	Pass

### 5.2. Statements

The MOBIPRINT<sup>3</sup> supporting GPRS/WCDMA/WiFi/BT, manufactured by MOBIWIRE MOBILES (NINGBO) CO.,LTD is a new product for testing. ECIT only performed test cases which identified with Pass/Fail/Inc result in section 5.1.

ECIT has verified that the compliance of the tested device specified in section 3 of this test report is successfully evaluated according to the procedure and test methods as defined in type certification requirement listed in section 4 of this test report.



## 6. Test Equipments Utilized

### 6.1 Radiated Emission Equipments list

No.	Name	Type	Series Number	Producer	Cal. Date	Cal. interval
1	Universal Radio Communication	CMU200	123102	R&S	2014-07-07	1
2	Test Receiver	ESU40	100307	R&S	2014-07-25	1
3	Trilog Antenna	VULB9163	VULB9163-515	Schwarzbeck	2014-11-05	3
4	Double Ridged Guide	ETS-3117	00135885	ETS	2014-05-06	3
5	EMI Test Software	EMC32 V9.15	NA	R&S	NA	NA

### 6.1 CE Equipments list

No.	Name	Type	Series Number	Producer	Cal. Date	Cal. interval
1	Universal Radio	CMU200	123124	R&S	2014-07-07	1
2	Test Receiver	ESCI	101235	R&S	2014-07-06	1
3	2-Line V-Network	ENV216	101380	R&S	2014-07-25	1
4	EMI Test Software	EMC32 V9.15	NA	R&S	NA	NA

## 7. System Configuration during Test

### 7.1 Test Mode

Test Item	Function Type
AC Conducted Emission	Mode 1: Idle + Camera on + USB cable (Data Link with PC) <Figure 1> Mode 2: Idle + Earphone + MP4 + Adapter charging <Figure 2>
Radiated Emission	Mode 1: Idle + Camera on + USB cable (Data Link with PC) <Figure 1> Mode 2: Idle + Earphone + MP4 + Adapter charging <Figure 2>
Remark: 1. All test modes are performed, only the worst cases test data are recorded in this report. 2. Data Link with PC means data application transferred mode between EUT and PC.	

### 7.2 Connection Diagram of Test System

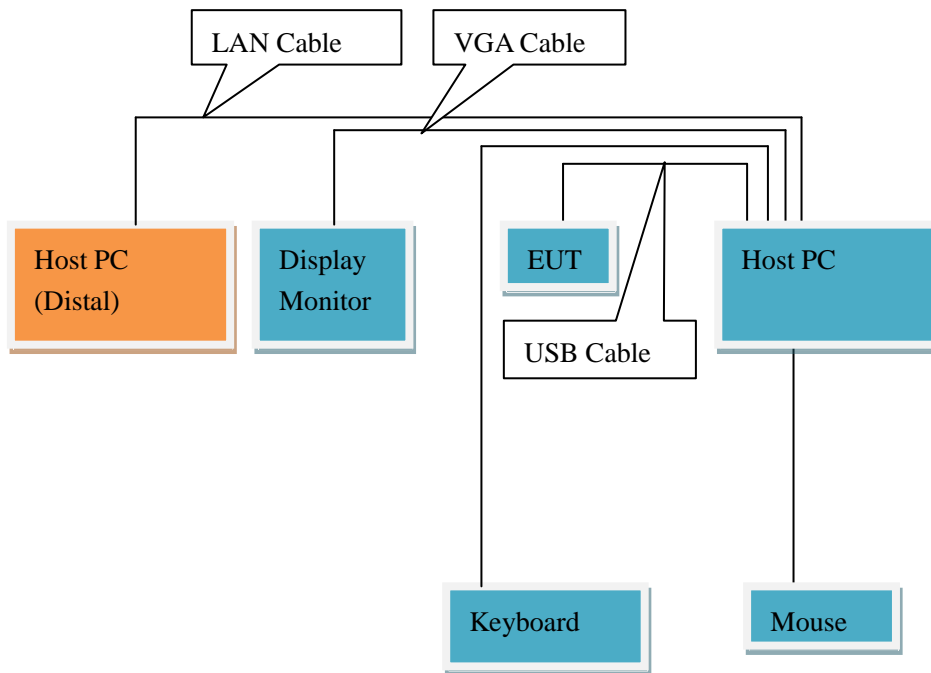

<Figure 1>



<Figure 2>

## 8. Measurement Results

Only the worst test result was shown in this report.

### 8.1 Radiated Emission 30MHz-12.75GHz

#### Method of Measurement

For 30-1000MHz, the EUT was placed on the top of a rotating 0.8-m table above the ground at a semi-anechoic chamber. The distance between the EUT and the received antenna was 3 meters. The table was rotated 360 degree and the received antenna mounted on a variable-height antenna tower was varied from 1m to 4m to find the maximum value of the field strength. Both horizontal and vertical polarizations of the antenna were set during the measurement. Tested in accordance with the procedures of ANSI C63.4-2009, section 8.3.

For 1000-12750MHz, The maximal emission value was acquired by adjusting the antenna height, The table was rotated 360 degree to determine the maximum value of the field strength. Both horizontal and vertical polarizations of the antenna were set during the measurement.

#### Limits for Radiated Emission at a measuring distance of 3m

Frequency Range (MHz)	Quasi-Peak (dBuV/m)
30-88	40
88-216	43.5
216-960	46
Above 960	54

Frequency Range (MHz)	Peak (dBuV/m)	Average (dBuV/m)
Above 1000	74	54

#### Test conditions

Frequency Range (MHz)	RBW/VBW	Sweep Time (s)
30-1000	120KHz/300KHz	Auto
1000-12750	1MHz/1MHz	Auto

#### Uncertainty Measurement

The measurement uncertainty is 5.59dB (k=2).

## Test Results

Mode 1: Idle + Camera on + USB cable (Data Link with PC)

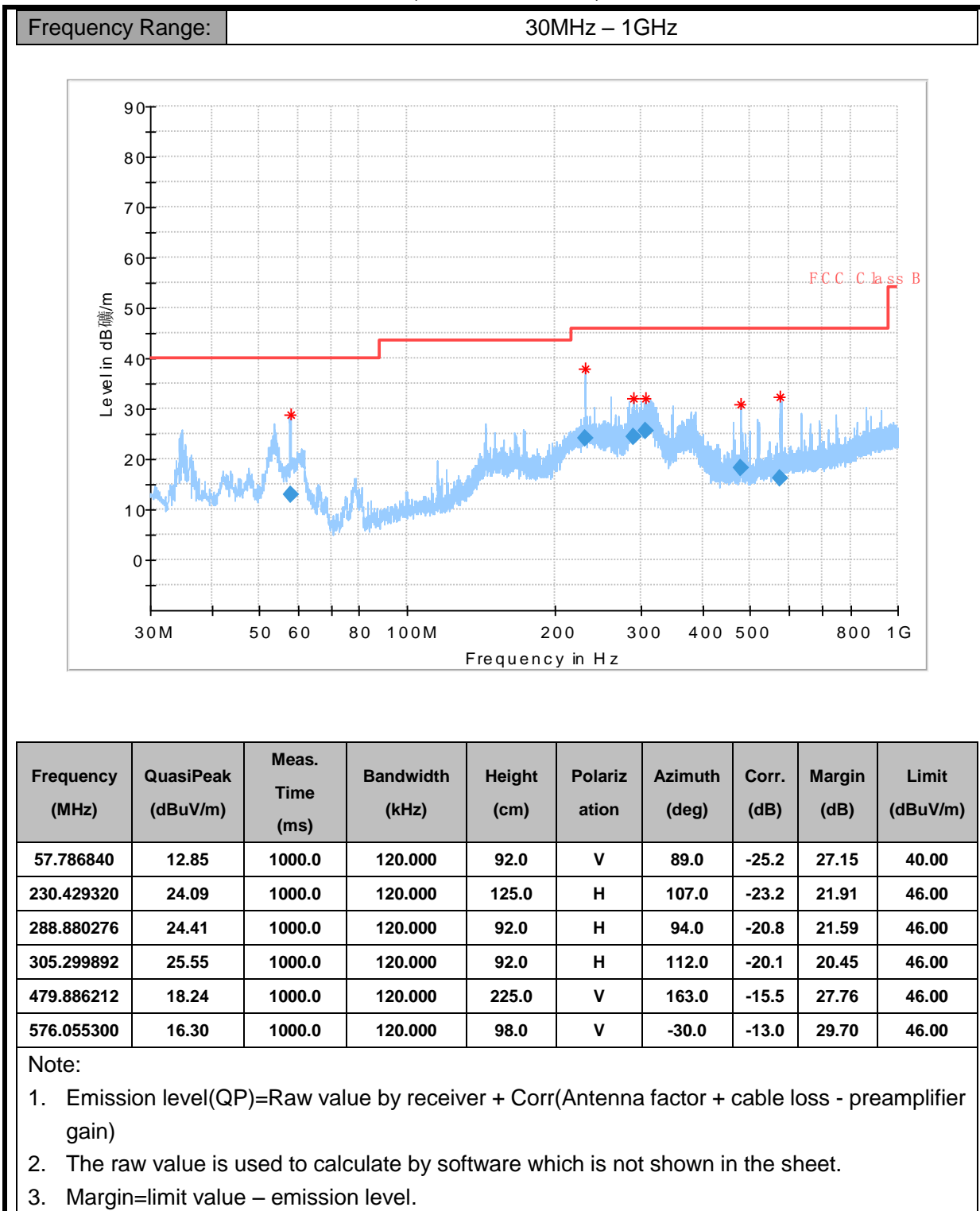

Mode 1: Idle + Camera on + USB cable (Data Link with PC)

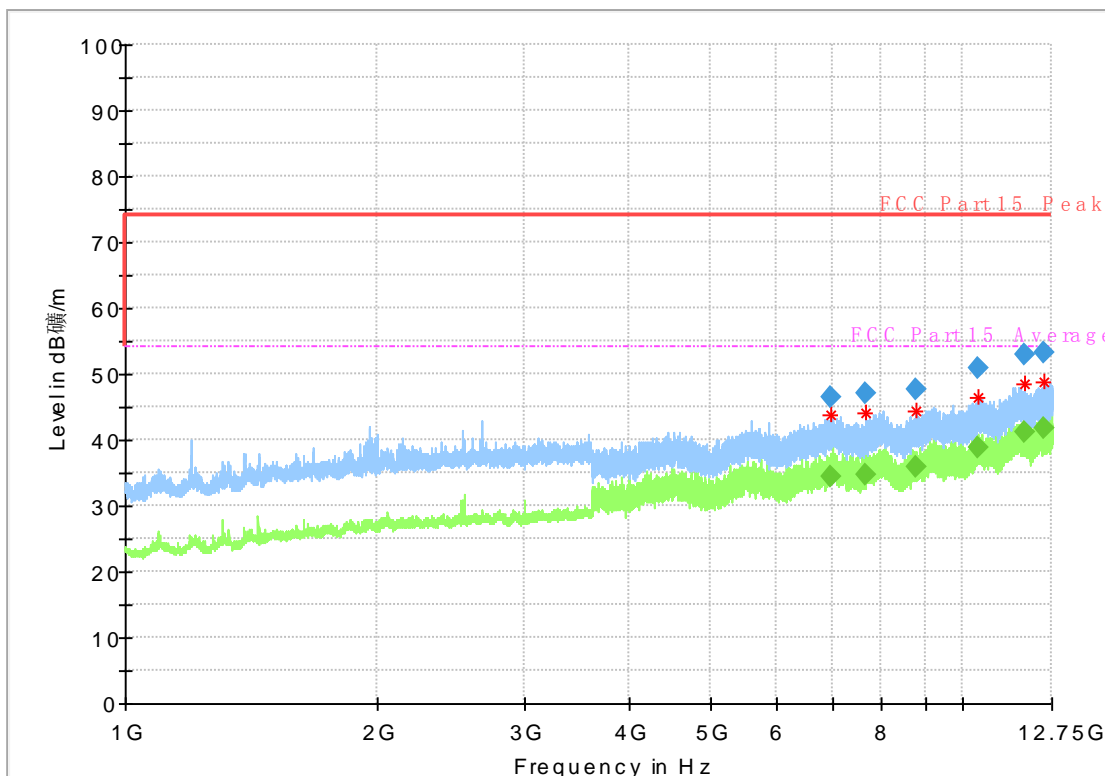

## Final\_Result

Frequency (MHz)	MaxPeak (dB µ V/m)	Average (dB µ V/m)	Limit (dB µ V/m)	Margin (dB)	Meas. Time	Bandwidth (kHz)	Height (cm)	Pol	Azimuth (deg)
6951.725334	---	34.50	54.00	19.50	50.0	1000.000	100.0	H	22.0
6951.725334	46.56	---	74.00	27.44	50.0	1000.000	100.0	H	22.0
7646.924933	---	34.59	54.00	19.41	50.0	1000.000	200.0	H	-4.0
7646.924933	46.98	---	74.00	27.02	50.0	1000.000	200.0	H	-4.0
8789.450933	---	35.74	54.00	18.26	50.0	1000.000	100.0	H	45.0
8789.450933	47.64	---	74.00	26.36	50.0	1000.000	100.0	H	45.0
10398.577867	50.99	---	74.00	23.01	50.0	1000.000	200.0	H	320.0
10398.577867	---	38.72	54.00	15.28	50.0	1000.000	200.0	H	320.0
11821.924200	52.88	---	74.00	21.12	50.0	1000.000	200.0	H	136.0
11821.924200	---	41.08	54.00	12.92	50.0	1000.000	200.0	H	136.0
12470.792200	---	41.78	54.00	12.22	50.0	1000.000	100.0	H	10.0
12470.792200	53.29	---	74.00	20.71	50.0	1000.000	100.0	H	10.0

Note:

1. Emission level(peak or average)=Raw value by receiver + Corr(Antenna factor+ cable loss - preamplifier gain)
2. The raw value is used to calculate by software which is not shown in the sheet.  
Margin=limit value – emission level.

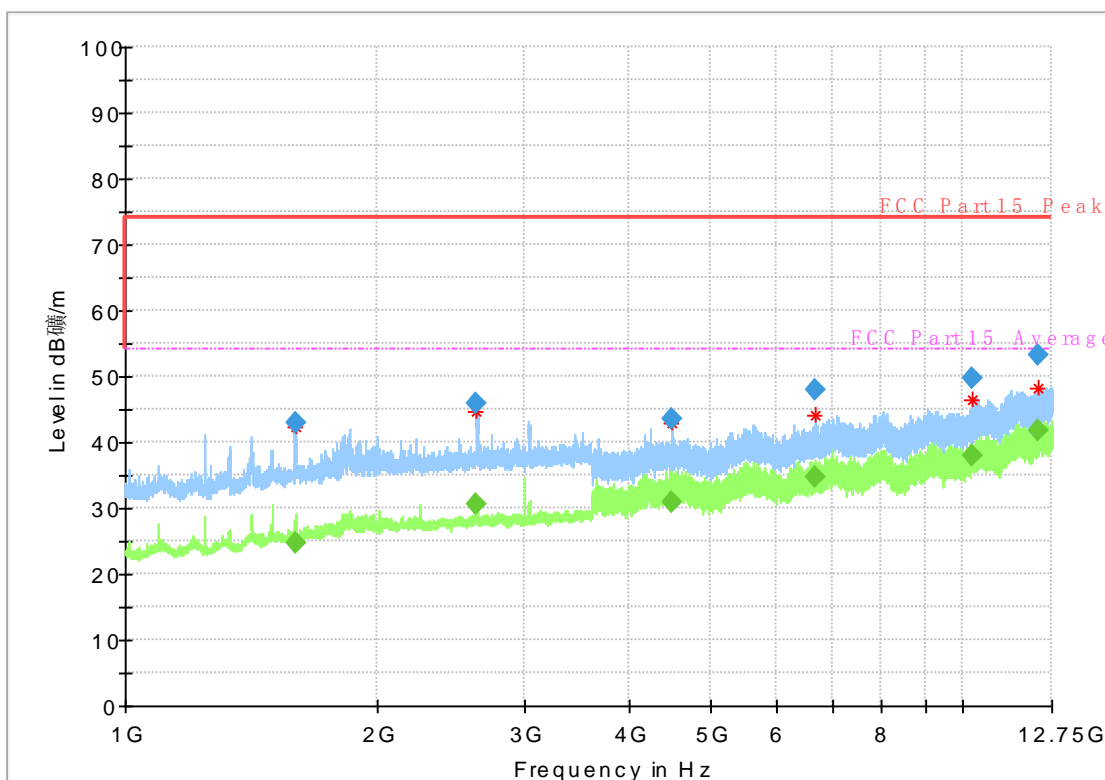

## Final\_Result

Frequency (MHz)	MaxPeak (dB μ V/m)	Average (dB μ V/m)	Limit (dB μ V/m)	Margin (dB)	Meas. Time	Bandwidth (kHz)	Height (cm)	Pol	Azimuth (deg)
1599.380467	---	24.68	54.00	29.32	50.0	1000.000	200.0	V	8.0
1599.380467	42.84	---	74.00	31.16	50.0	1000.000	200.0	V	8.0
2624.929934	---	30.72	54.00	23.28	50.0	1000.000	200.0	V	7.0
2624.929934	45.78	---	74.00	28.22	50.0	1000.000	200.0	V	7.0
4488.755466	43.54	---	74.00	30.46	50.0	1000.000	200.0	V	257.0
4488.755466	---	30.85	54.00	23.15	50.0	1000.000	200.0	V	257.0
6668.562333	47.81	---	74.00	26.19	50.0	1000.000	200.0	V	-22.0
6668.562333	---	34.56	54.00	19.44	50.0	1000.000	200.0	V	-22.0
10229.085800	49.63	---	74.00	24.37	50.0	1000.000	200.0	V	349.0
10229.085800	---	38.04	54.00	15.96	50.0	1000.000	200.0	V	349.0
12311.774933	53.35	---	74.00	20.65	50.0	1000.000	200.0	V	293.0
12311.774933	---	41.74	54.00	12.26	50.0	1000.000	200.0	V	293.0

Note:

1. Emission level(peak or average)=Raw value by receiver + Corr(Antenna factor+ cable loss - preamplifier gain)
2. The raw value is used to calculate by software which is not shown in the sheet.  
Margin=limit value – emission level.

## 8.2 Conducted Emission

### Method of Measurement

For equipment that is designed to be connected to the public utility (AC) power line, the radio frequency voltage that is conducted back onto the AC power line on any frequency or frequencies with the band 150 kHz to 30MHz shall not exceed the limits. Both lines of the power mains connected to the EUT were checked for maximum conducted interference. Tested in accordance with the procedures of ANSI C63.4-2009, section 7.3

### Limit of Conducted Emission

Frequency Range (MHz)	Conducted Limit (dBuV)	
	Quasi-peak	Average
0.15-0.5	66 to 56*	56 to 46*
0.5-5	56	46
5-30	60	50

\*Decreases with the logarithm of the frequency

### Test Condition in Charging Mode

Voltage (V)	Frequency (Hz)	RBW	Sweep Time (s)
120	60	9 KHz	Auto

### Uncertainty Measurement

The measurement uncertainty is 3.57dB (k=2).

### Test Results

Mode 1: Idle + Camera on + USB cable (Data Link with PC)

Frequency Range:

150kHz – 30MHz

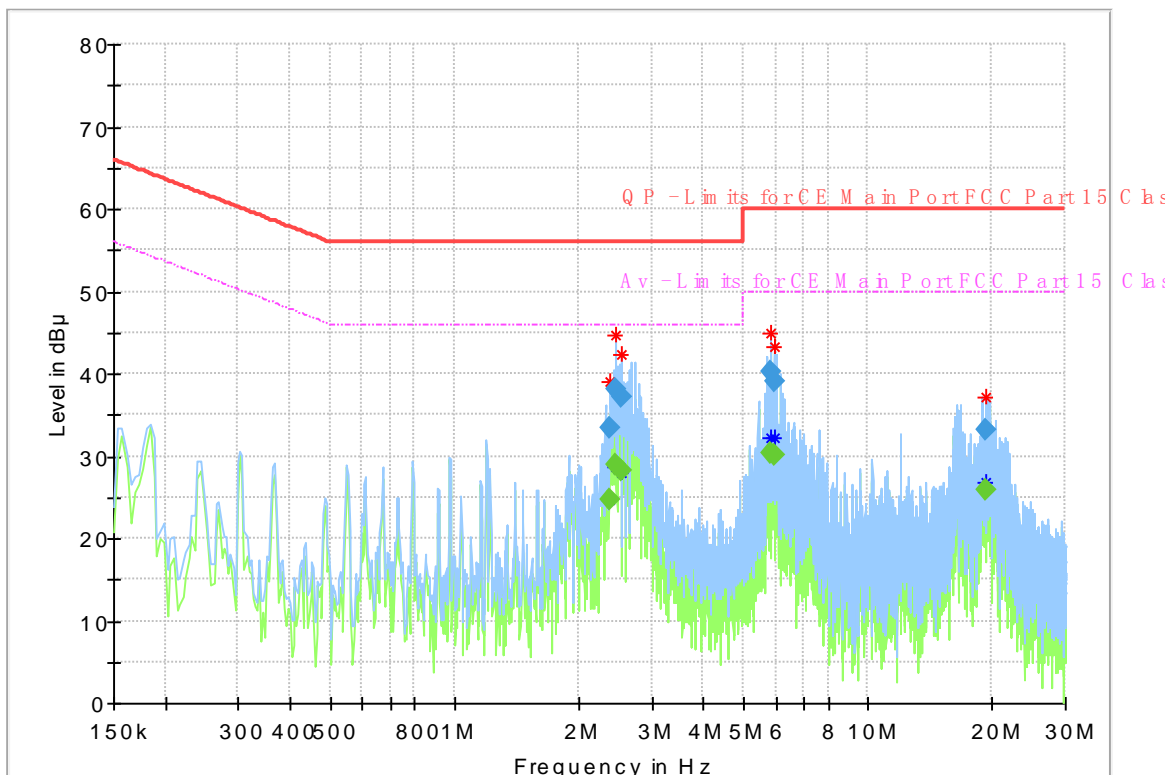

Frequency (MHz)	QuasiPeak (dB µ V)	Average (dB µ V)	Limit (dB µ V)	Margin (dB)	Meas. Time	Bandwidth (kHz)	Line	Filter	Corr. (dB)
2.370094	---	24.78	46.00	21.22	1000.0	9.000	L1	ON	9.8
2.370094	33.30	---	56.00	22.70	1000.0	9.000	L1	ON	9.8
2.444719	---	28.85	46.00	17.15	1000.0	9.000	N	ON	9.7
2.444719	38.18	---	56.00	17.82	1000.0	9.000	N	ON	9.7
2.541731	37.06	---	56.00	18.94	1000.0	9.000	L1	ON	9.8
2.541731	---	28.27	46.00	17.73	1000.0	9.000	L1	ON	9.8
5.791650	---	30.33	50.00	19.67	1000.0	9.000	L1	ON	9.8
5.791650	40.23	---	60.00	19.77	1000.0	9.000	L1	ON	9.8
5.914781	39.15	---	60.00	20.85	1000.0	9.000	L1	ON	9.8
5.914781	---	30.10	50.00	19.90	1000.0	9.000	L1	ON	9.8
19.291312	---	25.95	50.00	24.05	1000.0	9.000	N	ON	9.9
19.291312	33.26	---	60.00	26.74	1000.0	9.000	N	ON	9.9

Note:

1. Emission level(quasi-peak or Average peak)=Raw value by receiver + Corr(Insertion loss+cable loss)
2. The raw value is used to calculate by software which is not shown in the sheet.
3. Margin=limit value – emission level.

\*\*\*\*\*End the Report\*\*\*\*\*