

Product Dimensions

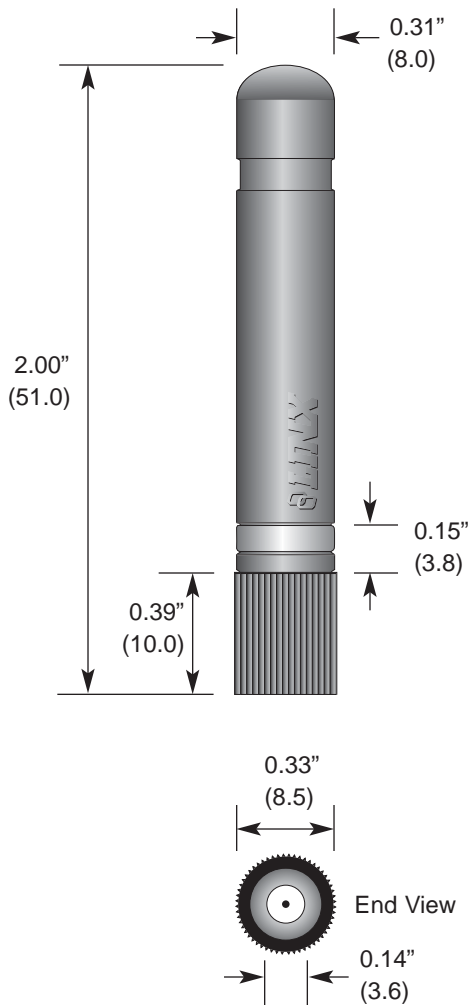

Description



The RH Series is designed to offer near straight monopole performance in an ultra-compact package. Ideal for small products where cosmetic or functional requirements dictate a compact, aesthetically pleasing antenna package. Despite their tiny size, RH Series antennas are ruggedly constructed and able to withstand punishing environments just like our larger whips.

Features

- Reduced-height helical whip
 - Low VSWR
 - Excellent performance
 - Omni-directional pattern
 - Fully weatherized
 - Rugged construction
 - Damage-resistant
 - Part 15 compliant RP-SMA connector
 - Use with plastic* or metal enclosures
- * Requires proximity ground plane

Electrical Specifications

- Center Freq. 916MHz
- Bandwidth 35MHz
- Wavelength 1/4-wave
- VSWR <1.9 typ. at center
- Impedance 50 ohms
- Gain TBD
- Connector RP-SMA

Note: Electrical specifications and plots measured on 4" x 4" reference ground plane

Ordering Information

- ANT-916-CW-RH

Plots

