



# FCC TEST REPORT

Model No. : 708  
Test Report No. : BWS-02-EF-0030

## BWS Tech., Inc.

294-9, Jungdae-Dong, Gwangju-City, Gyeonggi-Do 464-080 Korea  
TEL: 82 31 764 0125 FAX: 82 31 764 0126

## FCC EMI TEST REPORT

**Date of Test** : June 18, 2002  
**Test Report No.** : BWS-02-EF-0030  
**Test Site** : BWS Tech., Inc. (Registration No. : 553281)

**Applicant** : DQ Technology, Inc.  
**Trade Name** : N/A  
**Product Name** : ADSL MODEM  
**Model Name** : 708

**Manufacturer** : Serome Electronics Inc.  
**Manufacturer's Address** : #521-1 Yonghyun-Dong, Uijongbu-Si, Kyonggi-Do, Korea

**FCC Rule Part(s)** : FCC Part 15 Subpart B  
**Classification** : Class B

The device bearing the trade name and model specified above has been shown to comply with the applicable technical standards as indicated in the measurement report and was tested in accordance with the measurement procedures specified in ANSI C63.4-2000.

I attest to the accuracy of data and all measurement reported herein were performed by me or were made under my supervision and are correct to the best of my knowledge and belief. I assume full responsibility for the completeness of these measurements and vouch for the qualification of all persons taking them.

09. 13, 2002

Choi, Jae-Ho  
Technical director of BWS Tech., Inc.



---

TABLE OF CONTENTS	PAGE
1. Description of device -----	3
1.1 General -----	3
1.2 EUT Description -----	3
2. Test facility -----	4
3. Summary of results -----	4
3.1 Electromagnetic Emission -----	4
3.2 Modifications to the EUT -----	4
4. Tested system details -----	5
4.1 Peripherals and Others -----	5
4.2 Type of Cables Used -----	5
4.3 System layout on EUT and peripherals -----	6
5. Test result -----	7
5.1 RFI Voltage Measurement -----	7
5.2 RFI Field Strength Measurement -----	9
5.3 Minimum Margin -----	13
5.4 Sample Calculations -----	13
6. Test Equipments -----	14

## 1. DESCRIPTION OF DEVICE

---

### 1.1 General

Responsible Party Contact Person	<b>DQ Technology, Inc.</b> <b>Young I. Kim, President &amp; CEO</b> <b>Tel No. : 925.820.9675 Ext 16</b> <b>Fax No. : 925.820.9343</b>
Manufacturer	<b>Serome Electronics Inc.</b> <b>#521-1 Yonghyun-Dong, Uijongbu-Si,</b> <b>Kyonggi-Do, Korea</b>

- Trade name            **N/A**
- Model name            **708**
- EUT Type               **ADSL MODEM**
- Classification       **FCC Part 15 Subpart B   Class B**
- Clock Speed           **25.000 MHz**
- Rule Part(s)           **FCC Part 15 & Part 2**
- Test Procedure(s)   **ANSI C63.4-2000**
- Date of Tests          **Jun. 18, 2002**
- Place of Tests         **BWS Tech., Inc.**

### 1.2 EUT Description

 **Note.** This report may be reproduced in full. Partial reproduction may only be made with the written permission of the laboratory. The results in this report is only applied to the



sample(s) tested.

**Note.** Please refer to the duties and responsibilities of the Responsible Party attached.

## 2. TEST FACILITY

The open field test site and conducted measurement facility used for this measurement, is located following address. This site was fully described in a report dated Dec. 26, 2001 that was submitted to the FCC. Our site and facility had been accepted in a letter dated Dec. 26, 2001(Registration No. : 553281) :

BWS Tech, Inc.

Address : 294-9, Jungdae-Dong, Gwangju-City, Gyeonggi-Do 464-080 Korea

The detailed description of the measurement facility was found to be in compliance with the requirements of §2.948 according to ANSI C63.4 on Dec. 08, 2000.

## 3. SUMMARY OF RESULTS

### 3.1 Electromagnetic Emission

RFI Voltage Measurement ..... PASS

RFI Field Strength Measurement ..... PASS

Although the measured emissions indicate that the EUT complies with the required limits, some measurement are close to these limits.

When the uncertainty of measurement is considered, there is some possibility that the EUT may not be compliant.

### 3.2 Modifications to the EUT : None



# FCC TEST REPORT

Model No. : 708  
Test Report No. : BWS-02-EF-0030

## 4. TESTED SYSTEM DETAILS

### 4.1 Peripherals and Others :

Description	Model Name	Serial No.	Manufacturer	FCC ID
Computer	BWS TEST-1	-	-	-
Monitor	75EPLUS	P084H8WN710112	Changzin Electronic	-
Printer	C6464C	TH11RH70Q7	Calcomp Elec	-
Keyboard	RT6856T	B1861917	DIGITAL	AQ6-22K15
PS2 Mouse	OK-520	-	A4 TECH	DZL211029
Serial Mouse #1	AM-767-P	0119592	-	DoC
Serial Mouse #2	OK-520	-	A4 TECH	FSUGMZC7
Joystick	-	-	CREATIVE	DoC
Phone	SP-F111	-	SAMSUNG	
ADSL MODEM	708	-	Serome Electronics Inc.	EUT

### 4.2 Type of Cables Used:

Device from	Device to	Type of Cable	Length	Type of shield
Computer	Keyboard	Signal cable	1.0	Shielded
Computer	PS2 Mouse	Signal cable	1.0	Shielded
Computer	Mouse #1, #2	Signal cable	1.0	Shielded
Computer	Joystick	Signal cable	1.2	Shielded
Computer	Printer	Signal cable	1.2	Shielded
Computer	Monitor	Signal cable	1.0	Shielded
Power Cable	Power	-	1.5	Unshielded
EuT	PC (USB)	Signal cable	1.5	Unshielded
EuT	LINE (RJ-11)	Signal cable	20.0	Unshielded
EuT	PC (RJ-45)	Signal cable	1.5	Unshielded
EuT	Phone (RJ-11)	Signal cable	1.5	Unshielded
EuT	Adapter	-	1.5	Unshielded

**4.3 System layout on EUT and peripherals**

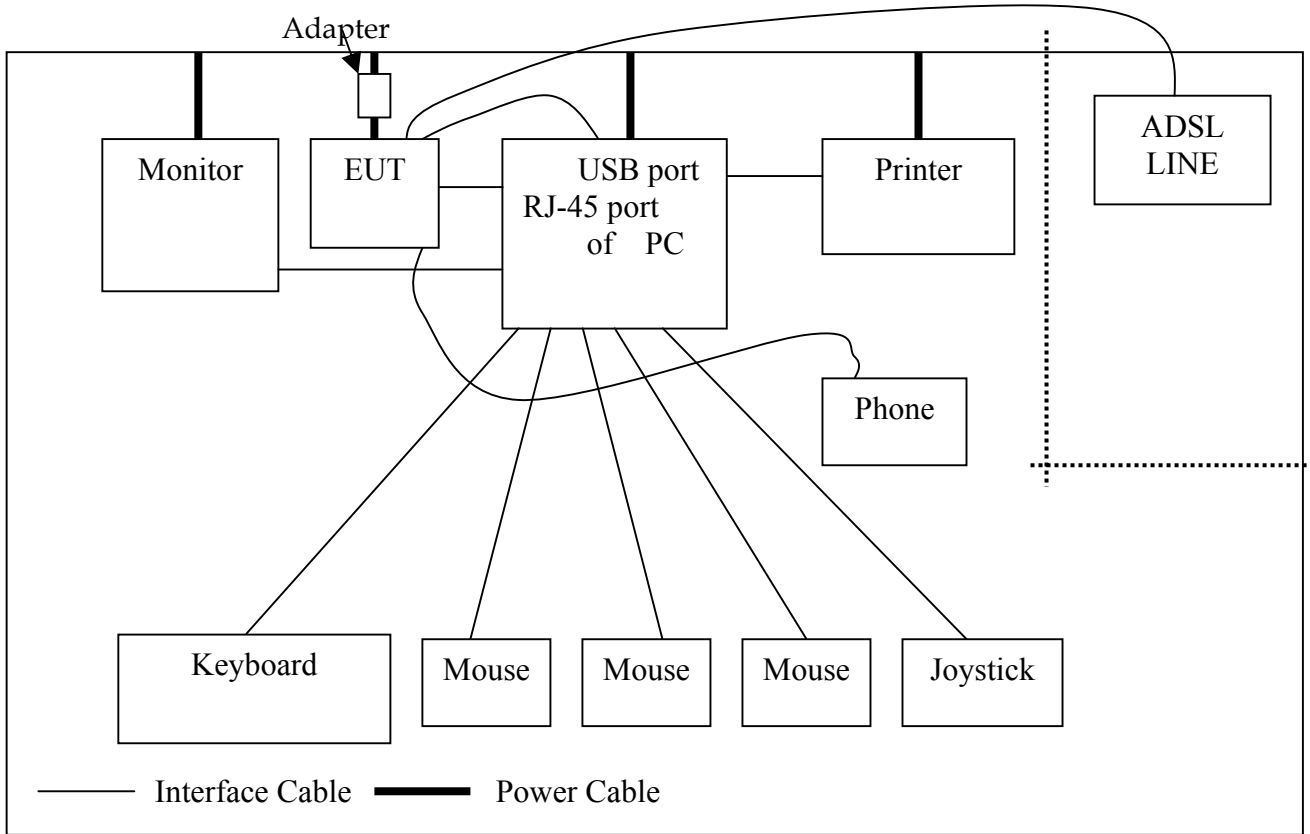

<Figure 4-1 System layout>

**5. TEST RESULT**



## 5.1 RFI Voltage Measurement

### 5.1.1 Measurement Instrumentation Used

*Measurement Instrument ... .. (model/serial no./manufacturer/last calibration/next calibration)*

EMI Receiver .....(ESH3/892580/R&S/21 May. 2002/May. 2003)

A.M.N. ....(L3-25/1110K70403/PMM/01 Sep. 2001/Sep. 2002)

Coaxial cable .....(RG213U/---/MARLOW/-/-)

Shield Room .....(JASH01/---/SEMITECH/---/---)

### 5.1.2 Measurement Procedure

The power line conducted interference measurement were performed according to ANSI C63.4-2000 in a Shielded room placed on a table, 0.8 m high over a metal floor. It was located more than required distance away from the shielded enclosure wall. Deviations from the standard was none. The EUT was plugged into the LISN and the frequency range of interest scanned. **We measured the EuT by using the "worst cast" condition.** We reported at maximum emission levels.

### 5.1.3 Operation Modes

EUT was tested according to the specifications given by the manufacturer, and exercised in the most unfavorable manner.

### 5.1.4 Measurement Uncertainty

Measurement uncertainty of RFI Voltage Measurement test was estimated at  $\pm 1.8$  dB(k=2)

### 5.1.5 Test Data







# FCC TEST REPORT

Model No. : 708  
Test Report No. : BWS-02-EF-0030

## PLOTS OF EMISSIONS

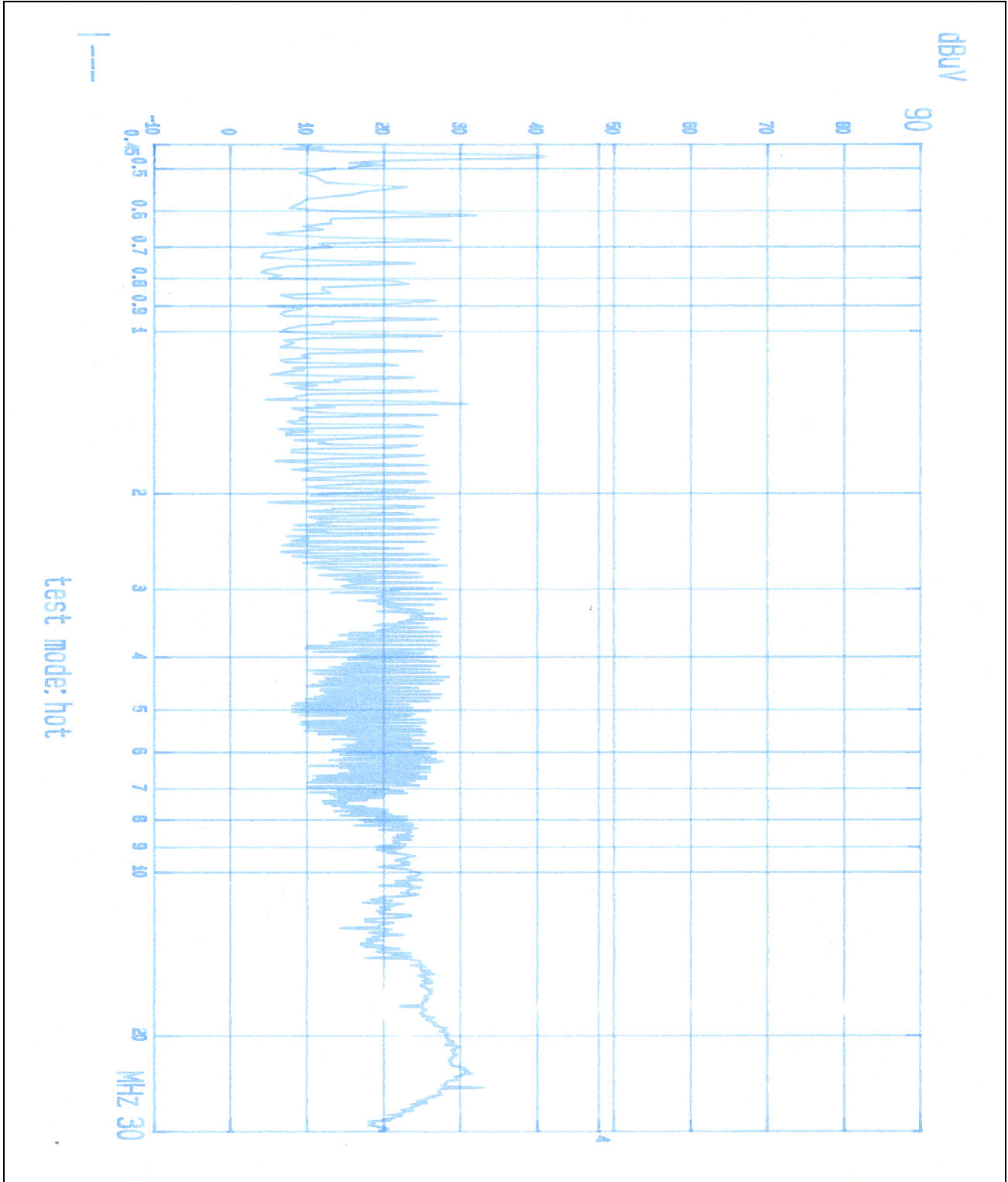

## PLOTS OF EMISSIONS

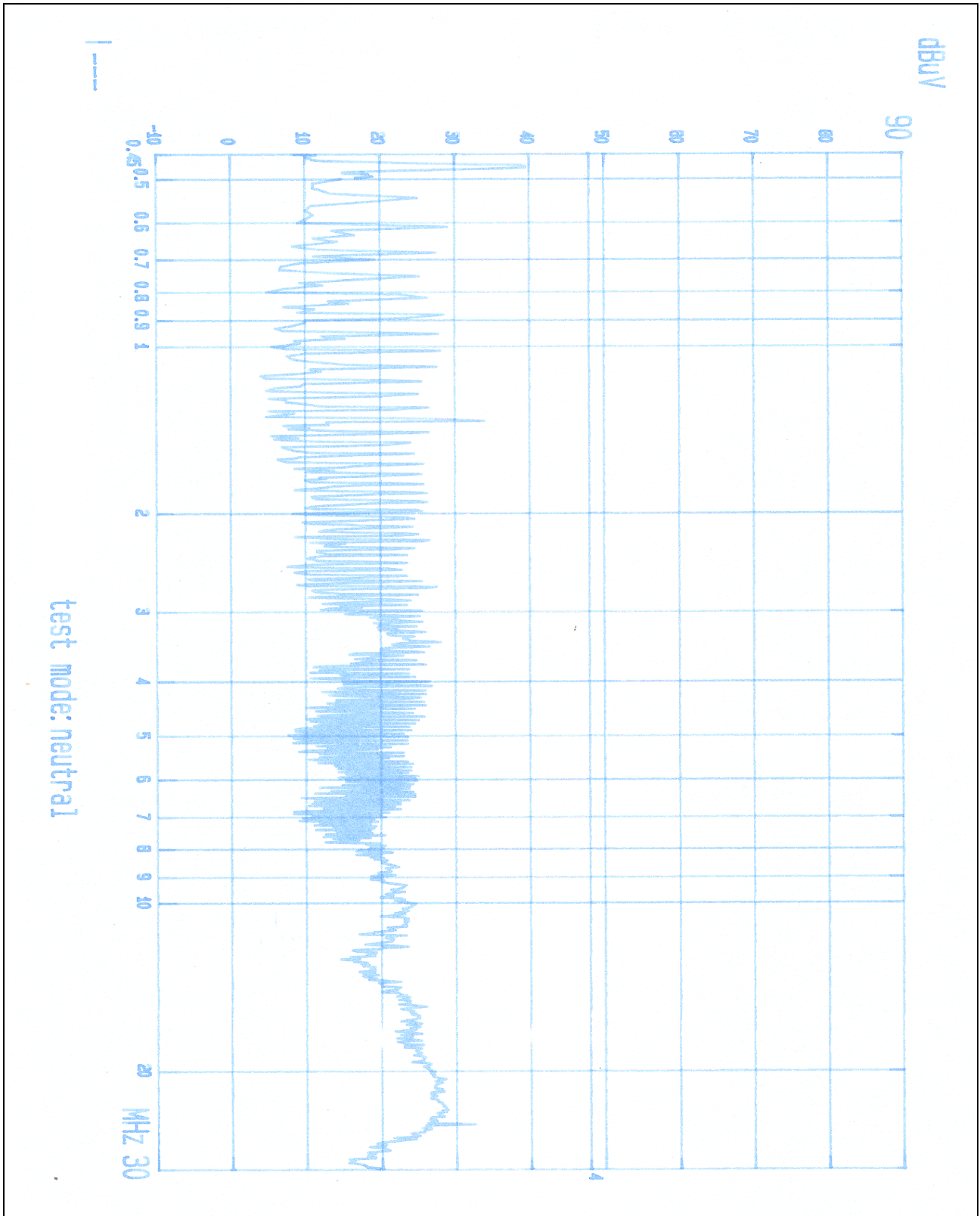

5.2.1 Measurement Instrumentation Used



# FCC TEST REPORT

Model No. : 708  
Test Report No. : BWS-02-EF-0030

(model/serial no./ manufacturer/last calibration/next calibration)

Spectrum Analyzer .....(R3261C/61720002/ Advantest/22 Aug. 2001/ Aug. 2002)

Biconical antenna ..... (BBA9106/-/ SWALZBECK /06 Sep. 2001/Sep. 2002)

Log periodic antenna ..... (UPA6109/1076/ SCHAFFNER /06 Sep. 2001/Sep. 2002)

Coaxial cable ..... (RG213U/---/MARLOW/--/--)

## 5.2.2 Measurement Procedure

Final test was performed according to ANSI C63.4-1992 at the open field site .  
Deviations from the standard were none.

The EUT was placed in a 0.8 m high table along with the peripherals. The turn table was separated from the antenna with the distance of 3 meter. Cables were placed in a position to produce maximum emissions as determined by experimentation, and operation mode was selected for maximum.

The frequencies and amplitudes of maximum emission were measured at varying azimuths, antenna heights and antenna polarities. **We measured the EuT by using the “worst case” condition .**  
We reported at maximum emission levels.

## 5.2.3 Operation Modes

EUT was tested according to the specifications given by the manufacturer, and exercised in the most unfavorable manner.

**During test, streaming data were down-loading for playing music through ADSL to computer.**

Measurement uncertainty of RFI Field Strength Measurement test was estimated at  $\pm 3.5$  dB(k=2)



# FCC TEST REPORT

Model No. : 708  
Test Report No. : BWS-02-EF-0030

## 5.2.5 Test Data

### RFI Field Strength Measurement Results(30 MHz to 1000 MHz)

Operating mode : "Worst case" condition mode  
Test procedure : ANSI C63.4-2000

Date of measurement : Jun. 18, 2002  
Temperature : 22 degree C  
Humidity : 49 %

Model : 708

MEASEMENT FREQ (MHz)	MEASEMEN TLEVEL (dBuV)	ANTENNA POLARITY (H/V)	ANTENNA FACTOR (dB)	CABLE LOSS (dB)	LIMIT (dBuV/m)	FIELD STRENGTH (dBuV/m)	MARGIN (dB)
48.01	24.90	V	11.64	1.24	40.00	37.78	-2.22
66.24	29.60	V	6.39	1.46		37.45	-2.55
159.98	20.90	H	15.20	2.51	43.50	38.61	-4.89
199.98	20.00	H	16.15	2.84		38.99	-4.51
399.98	19.30	H	15.16	4.19	46.00	38.65	-7.35
449.98	17.40	H	16.65	4.42		38.47	-7.53
499.96	19.00	H	17.58	4.69		41.27	-4.73
549.97	16.00	H	19.54	4.87		40.41	-5.59
674.98	12.90	H	20.40	5.56		38.86	-7.14
774.98	9.90	V	21.77	5.98		37.65	-8.35

Table 2. Radiated Measurements at 3meters.

### Note :

1. All modes of operation were investigated and the worst-case emissions are reported.
2. The limit for Class B digital device is 100  $\mu\text{V/m}$  (40.0 dB $\mu\text{V/m}$ ) from 30 MHz to 88 MHz, 150  $\mu\text{V/m}$  (43.5 dB $\mu\text{V/m}$ ) from 88 MHz to 216 MHz, 200  $\mu\text{V/m}$ (46.0 dB $\mu\text{V/m}$ ) from 216 MHz to 960 MHz and 500  $\mu\text{V/m}$  (53.98 dB $\mu\text{V/m}$ ) from above 960 MHz.

\* AFCL = Antenna Factor and Cable Loss

\*\* Measurements using CISPR quasi-peak mode. Above 1 GHz, peak detector function mode is using a resolution bandwidth of 1 MHz and a video bandwidth of 1 MHz.  
The peak level complies with the average limit. Peak mode is used with linearly polarized horn antenna and low-loss microwave cable.

Tested by **Hyung-Seok Lee**



# FCC TEST REPORT

Model No. : 708  
Test Report No. : BWS-02-EF-0030

## 5.3 Minimum Margin

### Conducted emission

708 "Worst case" condition mode 0.473 MHz, 7.0 dB

### Radiated emission

708 "Worst case" condition mode 48.01 MHz, 2.22 dB

## 5.4 SAMPLE CALCULATIONS

$$\begin{aligned} \text{dB}\mu\text{V} &= 20 \log_{10} (\mu\text{V}/\text{m}) \\ & \quad (\text{dB}\mu\text{V}/20) \\ \mu\text{V} &= 10 \end{aligned}$$

### EX. 1.

@ 0.473 MHz Class B limit = 250  $\mu\text{V}$  = 48 dB $\mu\text{V}$

Reading = 41.0 dB $\mu\text{V}$  (calibrated level)  
 $(41.0/20)$   
10 =  $\mu\text{V}$

Margin = 41.00 - 48 = -7.00  
**7.0 dB ; below limit**

### EX. 2.

@ 48.01 MHz Class B limit = 100  $\mu\text{V}/\text{m}$  = 40.0 dB $\mu\text{V}/\text{m}$

Reading = 24.90 dB $\mu\text{V}$ (calibrated level)  
Antenna factor + Cable Loss = 12.88 dB  
Total = 37.78 dB $\mu\text{V}/\text{m}$   
 $(37.78/20)$   
10 =  $\mu\text{V}/\text{m}$

Margin = 37.78 - 40.0 = -2.22 dB  
**2.22 dB ; below limit**



# FCC TEST REPORT

Model No. : 708  
Test Report No. : BWS-02-EF-0030

## 6. TEST EQUIPMENTS

The listing below denotes the test equipments utilized for the test(s).

<u>Nomenclature</u>	<u>Manufacture Model Number</u>	<u>Serial Number</u>	<u>Calibration Date</u>
Spectrum Analyzer (9kHz - 2.6GHz)	ADVANTEST R3261C	61720002	01/08/22
EMI Receiver	ROHDE& SCHWARZ ESH3	892580/014	02/05/21
Amplifier (0.1MHz-1.3GHz)	HP 8447E	2945A02712	01/08/19
Biconical Antenna	PMM BC01	0020J70501	01/10/10
Biconical Antenna	SWALZBECK BBA9106	-	01/09/06
Log Periodic Antenna	PMM LP01	0020J70501	01/10/10
Log Periodic Antenna	SCHAFFNER UPA6109	1076	01/09/06
Dipole Antenna	SCHAFFNER VDA6106A	1277	01/09/10
Dipole Antenna	SCHAFFNER UHA9105	19052168	01/09/10
Plotter	HP 7475A	007475A	-
Shield Room 7m x 4m x 4m	SEMITECH -	000815	-
Turn Table	JAEMC JAC-2	-	-
Antenna Mast	Dae-il EMC JAC-1	-	-
Artificial Mains Network	KYORITSU KNW-242C	8-920-20	01/08/09
Artificial Mains Network	PMM L3-25	1110K70403	01/09/01