

RADIO TEST REPORT

FCC ID: QMH-CL3239

Product: Wi-Fi Doorbell
Trade Mark: iCreation, Xingtel
Model No.: CL-3239
Serial Model: N/A
Report No.: SER171216602002E
Issue Date: 13 Mar. 2018

Prepared for

Xingtel Xiamen Group Co., Ltd.
Xingtel Building, Chuangxin Road, Torch Hi-Tech Industrial
District, Xiamen 361006, PR China

Prepared by

Shenzhen NTEK Testing Technology Co., Ltd.
1/F, Building E, Fenda Science Park, Sanwei Community,
Xixiang Street Bao'an District, Shenzhen 518126 P.R. China
Tel.: +86-755-6115 9388
Fax.: +86-755-6115 6599
Website: <http://www.ntek.org.cn>

Table of Contents
Page

1. TEST RESULT CERTIFICATION	4
2. SUMMARY OF TEST RESULTS	5
3. FACILITIES AND ACCREDITATIONS	6
3.1 FACILITIES	6
3.2 LABORATORY ACCREDITATIONS AND LISTINGS	6
3.3 MEASUREMENT UNCERTAINTY	6
4. GENERAL DESCRIPTION OF EUT	7
5. DESCRIPTION OF TEST MODES	9
6. SETUP OF EQUIPMENT UNDER TEST	10
6.1 BLOCK DIAGRAM CONFIGURATION OF TEST SYSTEM	10
6.2 DESCRIPTION OF SUPPORT UNITS(CONDUCTED MODE)	11
6.3 EQUIPMENTS LIST FOR ALL TEST ITEMS	12
7. ANTENNA REQUIREMENT	14
7.1 STANDARD REQUIREMENT	14
7.2 EUT ANTENNA	14
8. CONDUCTED EMISSION MEASUREMENT	15
8.1 APPLICABLE STANDARD	15
8.2 CONFORMANCE LIMIT	15
8.3 MEASURING INSTRUMENTS	15
8.4 TEST CONFIGURATION	15
8.5 TEST PROCEDURE	15
8.6 TEST RESULTS	16
9. RADIATED EMISSION MEASUREMENT	20
9.1 APPLICABLE STANDARD	20
9.2 RADIATED EMISSION LIMITS	20
9.3 TEST PROCEDURE	21
9.4 TEST SETUP	23
9.5 TEST RESULTS	24
10. BANDWIDTH TEST	29
10.1 TEST PROCEDURE	29
10.2 DEVIATION FROM STANDARD	29
10.3 TEST SETUP	29
10.4 TEST RESULTS	30
11. TRANSMITTER TIMEOUT	31

Table of Contents	Page
11.1 REQUIREMENTS	31
APPENDIX-PHOTOGRAPHS OF EUT CONSTRUCTIONAL DETAILS	

1. TEST RESULT CERTIFICATION

Applicant's name..... :	Xingtel Xiamen Group Co., Ltd.
Address	Xingtel Building,Chuangxin Road, Torch Hi-Tech Industrial District,Xiamen 361006, PR China
Manufacturer's Name..... :	Xingtel Xiamen Group Co., Ltd.
Address	Xingtel Building,Chuangxin Road, Torch Hi-Tech Industrial District,Xiamen 361006, PR China
Product description	
Product name..... :	Wi-Fi Doorbell
Model and/or type reference	CL-3239
Serial Model	N/A

Measurement Procedure Used:

APPLICABLE STANDARDS	
APPLICABLE STANDARD/ TEST PROCEDURE	TEST RESULT
FCC 47 CFR Part 15, Subpart C KDB 174176 D01 Line Conducted FAQ v01r01 ANSI C63.10-2013	Complied

This device described above has been tested by Shenzhen NTEK Testing Technology Co., Ltd., and the test results show that the equipment under test (EUT) is in compliance with the FCC requirements. And it is applicable only to the tested sample identified in the report.

This report shall not be reproduced except in full, without the written approval of Shenzhen NTEK Testing Technology Co., Ltd., this document may be altered or revised by Shenzhen NTEK Testing Technology Co., Ltd. personnel only, and shall be noted in the revision of the document.

The test results of this report relate only to the tested sample identified in this report.

Date of Test : 16 Dec. 2017 ~ 13 Mar. 2018

Testing Engineer : Susan Su
(Susan Su)

Technical Manager : Jason Chen
(Jason Chen)

Authorized Signatory : Sam. Chen
(Sam Chen)

2. SUMMARY OF TEST RESULTS

FCC Part15 (15.231a), Subpart C			
Standard Section	Test Item	Judgment	Remark
15.207	Conducted Emission	Pass	
15.203	Antenna Requirement	Pass	
15.231	Radiated Spurious Emission	Pass	
15.231	Occupied Bandwidth	Pass	
15.231	Transmitter Timeout	Pass	

NOTE:

(1) "N/A" denotes test is not applicable in this Test Report.

3.FACILITIES AND ACCREDITATIONS

3.1 FACILITIES

All measurement facilities used to collect the measurement data are located at
 1/F, Building E, Fenda Science Park, Sanwei Community, Xixiang Street, Bao'an District, Shenzhen 518126
 P.R. China

The sites are constructed in conformance with the requirements of ANSI C63.7, ANSI C63.10 and CISPR
 Publication 22.

3.2 LABORATORY ACCREDITATIONS AND LISTINGS

Site Description

CNAS-Lab. : The Laboratory has been assessed and proved to be in compliance with
 CNAS-CL01:2006 (identical to ISO/IEC 17025:2005)
 The Certificate Registration Number is L5516.

IC-Registration The Certificate Registration Number is 9270A-1.

FCC- Accredited Test Firm Registration Number: 463705.

Designation Number: CN1184

A2LA-Lab. The Certificate Registration Number is 4298.01

This laboratory is accredited in accordance with the recognized
 International Standard ISO/IEC 17025:2005 General requirements for
 the competence of testing and calibration laboratories.

This accreditation demonstrates technical competence for a defined
 scope and the operation of a laboratory quality management system
 (refer to joint ISO-ILAC-IAF Communiqué dated 8 January 2009).

Name of Firm : Shenzhen NTEK Testing Technology Co., Ltd.

Site Location : 1/F, Building E, Fenda Science Park, Sanwei Community, Xixiang
 Street, Bao'an District, Shenzhen 518126 P.R. China.

3.3 MEASUREMENT UNCERTAINTY

The reported uncertainty of measurement $y \pm U$, where expended uncertainty U is based on a standard
 uncertainty multiplied by a coverage factor of $k=2$, providing a level of confidence of approximately 95 %.

No.	Item	Uncertainty
1	Conducted Emission Test	$\pm 2.80\text{dB}$
2	RF power, conducted	$\pm 0.16\text{dB}$
3	Spurious emissions, conducted	$\pm 0.21\text{dB}$
4	All emissions, radiated(30MHz~1GHz)	$\pm 2.64\text{dB}$
5	All emissions, radiated(1GHz~6GHz)	$\pm 2.40\text{dB}$
6	All emissions, radiated(> 6GHz)	$\pm 2.52\text{dB}$
7	Temperature	$\pm 0.5^\circ\text{C}$
8	Humidity	$\pm 2\%$

4. GENERAL DESCRIPTION OF EUT

Equipment	Wi-Fi Doorbell
Trade Name	iCreation, Xingtel
Model Name	CL-3239
Serial Model	N/A
Model Difference	N/A
Product Description	The EUT is a Wi-Fi Doorbell
	Operation Frequency: 433.92MHz
	Modulation Type: ASK
	Number Of Channel: 1CH
	Antenna Designation: Cable Antenna
	Antenna Gain: 1dBi
	Field Strength: 59.40dBuV/m
	Based on the application, features, or specification exhibited in User's Manual, the EUT is considered as an ITE/Computing Device. More details of EUT technical specification, please refer to the User's Manual.
Channel List	Refer to below
Power supply	AC 9-24V or DC36V For Adapter (Note 2) AC 9V For Adapter For Conducted Emission Measurement
Adapter	N/A
Battery	DC 3.7V,250mAh For Radiated Emission Measurement (Note 2)
HW Version	H15DBB
SW Version	0804051034

Note:

- For a more detailed features description, please refer to the manufacturer's specifications or the User's Manual.
- EUT supports multiple voltage inputs.
Conducted Emission Measurement The worst voltage condition is Adapter AC 9V
Radiated Emission Measurement The worst voltage condition is Battery DC 3.7V
Only the worst test patterns were recorded in the report.

3.

Channel	Frequency (MHz)
01	433.92MHz
--	--

5. DESCRIPTION OF TEST MODES

To investigate the maximum EMI emission characteristics generates from EUT, the test system was pre-scanning tested base on the consideration of following EUT operation mode or test configuration mode which possible have effect on EMI emission level. Each of these EUT operation mode(s) or test configuration mode(s) mentioned above was evaluated respectively.

Pretest Mode	Description
Mode 1	TX

For Conducted Emission	
Final Test Mode	Description
Mode 1	TX

For Radiated Emission	
Final Test Mode	Description
Mode 1	TX

6. SETUP OF EQUIPMENT UNDER TEST

6.1 BLOCK DIAGRAM CONFIGURATION OF TEST SYSTEM

For AC Conducted Emission Mode

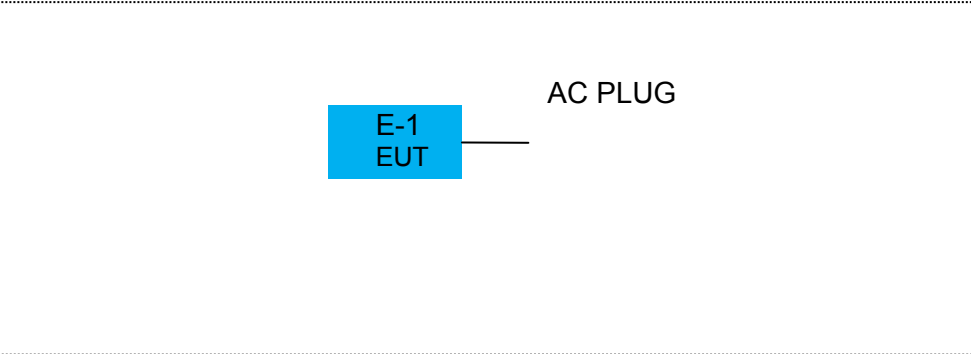

For Radiated Test Cases

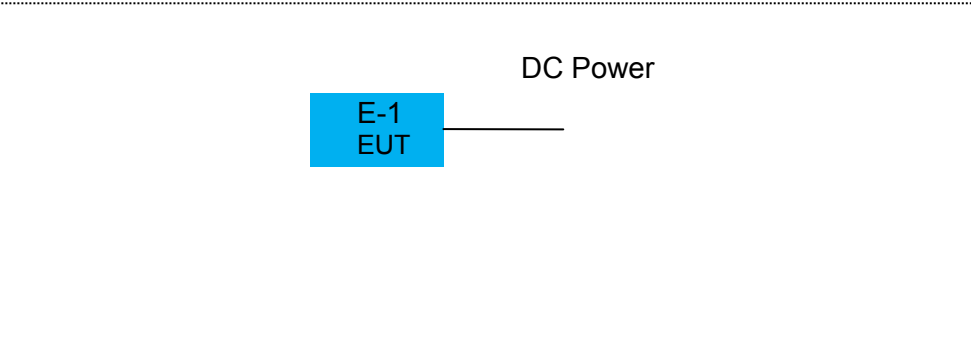

For Conducted Test Cases

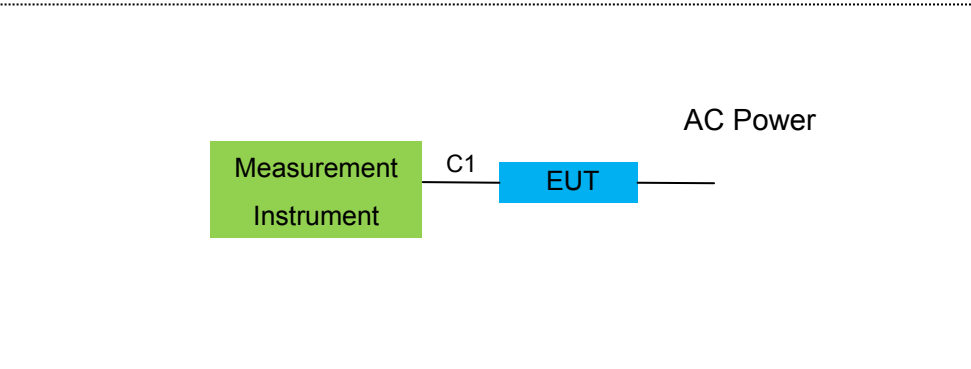

Note: The temporary antenna connector is soldered on the PCB board in order to perform conducted tests and this temporary antenna connector is listed in the equipment list.

6.2 DESCRIPTION OF SUPPORT UNITS(CONDUCTED MODE)

The EUT has been tested as an independent unit together with other necessary accessories or support units. The following support units or accessories were used to form a representative test configuration during the tests.

Item	Equipment	Mfr/Brand	Model/Type No.	FCC ID	Note
E-1	Wi-Fi Doorbell	iCreation, Xingtel	CL-3239	QMHCL-3239	EUT

Item	Cable Type	Shielded Type	Ferrite Core	Length
C-1	RF Cable	NO	NO	0.5m

Note:

- (1) The support equipment was authorized by Declaration of Confirmation.
- (2) For detachable type I/O cable should be specified the length in cm in 『Length』 column.
- (3) “YES” is means “shielded” “with core”; “NO” is means “unshielded” “without core”.

6.3 EQUIPMENTS LIST FOR ALL TEST ITEMS

Radiation Test equipment

Item	Kind of Equipment	Manufacturer	Type No.	Serial No.	Last calibration	Calibrated until	Calibration period
1	Spectrum Analyzer	Agilent	E4407B	MY45108040	2017.06.06	2018.06.05	1 year
2	Spectrum Analyzer	Agilent	N9020A	MY49100060	2017.11.10	2018.11.09	1 year
3	EMI Test Receiver	Agilent	N9038A	MY53227146	2017.06.06	2018.06.05	1 year
4	Test Receiver	R&S	ESPI	101318	2017.06.06	2018.06.05	1 year
5	Bilog Antenna	TESEQ	CBL6111D	31216	2017.04.09	2018.04.08	1 year
6	50Ω Coaxial Switch	Anritsu	MP59B	6200983705	2017.06.06	2018.06.05	1 year
7	Horn Antenna	EM	EM-AH-10180	2011071402	2017.04.09	2018.04.08	1 year
8	Horn Ant	Schwarzbeck	BBHA 9170	9170-181	2017.07.06	2018.07.05	1 year
9	Amplifier	EMC	EMC051835SE	980246	2017.08.09	2018.08.08	1 year
10	Amplifier	MITEQ	TTA1840-35-HG	177156	2017.06.06	2018.06.05	1 year
11	Loop Antenna	ARA	PLA-1030/B	1029	2017.06.06	2018.06.05	1 year
12	Power Meter	DARE	RPR3006W	15100041SN084	2017.08.07	2018.08.06	1 year
13	Test Cable (9KHz-30MHz)	N/A	R-01	N/A	2017.04.21	2020.04.20	3 year
14	Test Cable (30MHz-1GHz)	N/A	R-02	N/A	2017.04.21	2020.04.20	3 year
15	High Test Cable(1G-40G Hz)	N/A	R-03	N/A	2017.04.21	2020.04.20	3 year
16	High Test Cable(1G-40G Hz)	N/A	R-04	N/A	2017.04.21	2020.04.20	3 year
17	temporary antenna connector (Note)	NTS	R001	N/A	N/A	N/A	N/A

Note:

We will use the temporary antenna connector (soldered on the PCB board) When conducted test
And this temporary antenna connector is listed within the instrument list

Conduction Test equipment

Item	Kind of Equipment	Manufacturer	Type No.	Serial No.	Last calibration	Calibrated until	Calibration period
1	Test Receiver	R&S	ESCI	101160	2017.06.06	2018.06.05	1 year
2	LISN	R&S	ENV216	101313	2017.04.19	2018.04.18	1 year
3	LISN	SCHWARZBECK	NNLK 8129	8129245	2017.06.06	2018.06.05	1 year
4	50Ω Coaxial Switch	ANRITSU CORP	MP59B	6200983704	2017.06.06	2018.06.05	1 year
5	Test Cable (9KHz-30MHz)	N/A	C01	N/A	2017.04.21	2020.04.20	3 year
6	Test Cable (9KHz-30MHz)	N/A	C02	N/A	2017.04.21	2020.04.20	3 year
7	Test Cable (9KHz-30MHz)	N/A	C03	N/A	2017.04.21	2020.04.20	3 year

1	Filter	TRILTHIC	2400MHz	29	2017.04.19	2018.04.18	1 year
---	--------	----------	---------	----	------------	------------	--------

Note: Each piece of equipment is scheduled for calibration once a year except the Test Cable which is scheduled for calibration every 3 years.

7. ANTENNA REQUIREMENT

7.1 STANDARD REQUIREMENT

15.203 requirement: For intentional device, according to 15.203: an intentional radiator shall be designed to ensure that no antenna other than that furnished by the responsible party shall be used with the device.

7.2 EUT ANTENNA

The EUT antenna is permanent attached Cable Antenna(Gain: 1dBi). It comply with the standard requirement.

8. CONDUCTED EMISSION MEASUREMENT

8.1 Applicable Standard

According to FCC Part 15.207(a) and KDB 174176 D01 Line Conducted FAQ v01r01

8.2 Conformance Limit

Frequency(MHz)	Conducted Emission Limit	
	Quasi-peak	Average
0.15-0.5	66-56*	56-46*
0.5-5.0	56	46
5.0-30.0	60	50

Note: 1. *Decreases with the logarithm of the frequency
 2. The lower limit shall apply at the transition frequencies
 3. The limit decreases in line with the logarithm of the frequency in the range of 0.15 to 0.50MHz.

8.3 Measuring Instruments

The Measuring equipment is listed in the section 6.3 of this test report.

8.4 Test Configuration

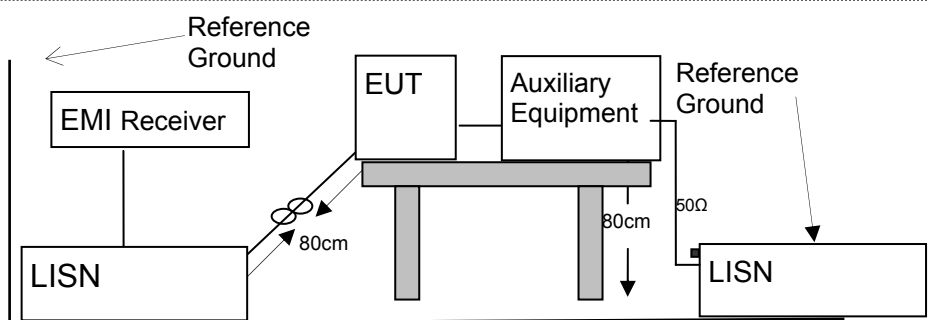

8.5 Test Procedure

According to the requirements in Section 13.1.4.1 of ANSI C63.10-2013 Conducted emissions the EUT measured in the frequency range between 0.15 MHz and 30 MHz using CISPR Quasi-Peak and average detector mode.

1. The EUT was placed 0.4 meter from the conducting wall of the shielding room.
2. The EUT was placed on a table which is 0.8m above ground plane.
3. Connect EUT to the power mains through a line impedance stabilization network (LISN). All other support equipments powered from additional LISN(s). The LISN provide 50 Ohm/ 50uH of coupling impedance for the measuring instrument.
4. Interconnecting cables that hang closer than 40 cm to the ground plane shall be folded back and forth in the center forming a bundle 30 to 40cm long.
5. I/O cables that are not connected to a peripheral shall be bundled in the center. The end of the cable may be terminated, if required, using the correct terminating impedance. The overall length shall not exceed 1 m.
6. LISN at least 80 cm from nearest part of EUT chassis.
7. The frequency range from 150KHz to 30MHz was searched.
8. Set the test-receiver system to Peak Detect Function and specified bandwidth(IF bandwidth=9KHz) with Maximum Hold Mode
9. For the actual test configuration, please refer to the related Item –EUT Test Photos.

8.6 Test Results

EUT :	Wi-Fi Doorbell	Model Name :	CL-3239
Temperature :	26 °C	Relative Humidity :	54%
Pressure :	1010hPa	Phase :	L
Test Voltage :	AC 9V For Adapter AC 120V/60Hz	Test Mode :	Mode 1

Frequency (MHz)	Reading Level (dBμV)	Correct Factor (dB)	Measure-ment (dBμV)	Limits (dBμV)	Margin (dB)	Remark
0.4178	29.78	9.83	39.61	57.49	17.88	QP
0.4178	22.32	9.83	32.15	47.49	15.34	AVG
0.8336	29.27	9.87	39.14	56.00	16.86	QP
0.8336	22.16	9.87	32.03	46.00	13.97	AVG
3.3380	23.81	10.05	33.86	56.00	22.14	QP
3.3380	14.32	10.05	24.37	46.00	21.63	AVG
5.8379	23.47	10.02	33.49	60.00	26.51	QP
5.8379	12.35	10.02	22.37	50.00	27.63	AVG
12.5099	20.12	10.10	30.22	60.00	29.78	QP
12.5099	12.57	10.10	22.67	50.00	27.33	AVG
15.4379	22.45	10.22	32.67	60.00	27.33	QP
15.4379	13.42	10.22	23.64	50.00	26.36	AVG

Remark:

1. All readings are Quasi-Peak and Average values.
2. Factor = Insertion Loss + Cable Loss.

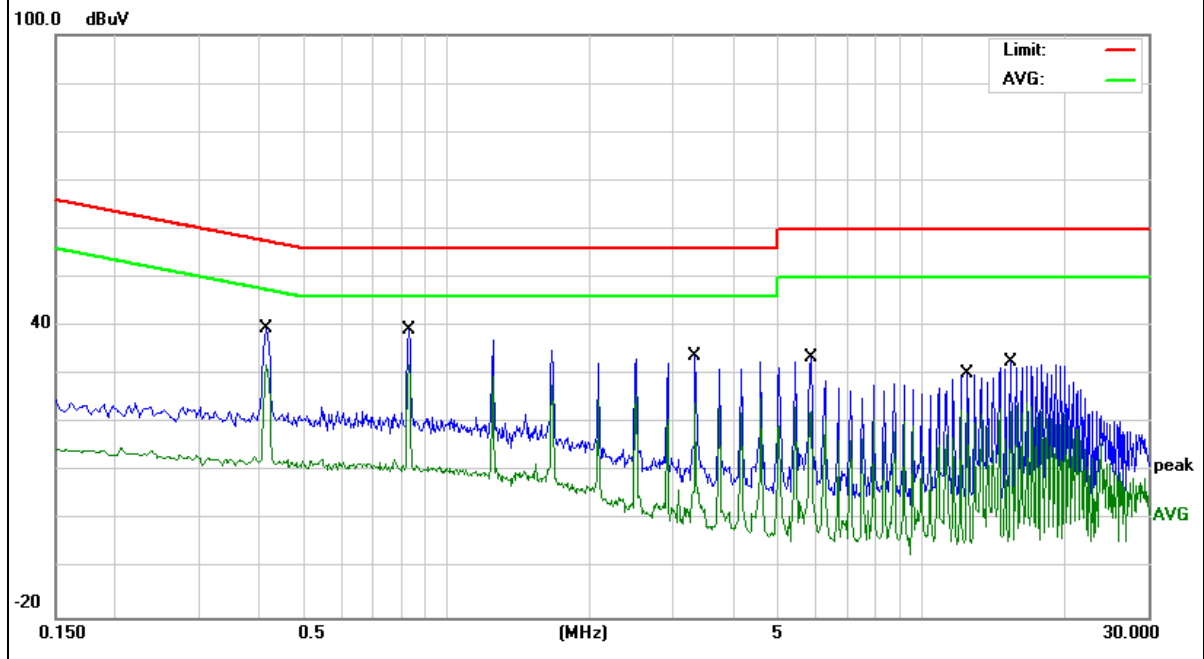

EUT :	Wi-Fi Doorbell	Model Name :	CL-3239
Temperature :	25 °C	Relative Humidity :	55%
Pressure :	1010hPa	Phase :	N
Test Voltage :	AC 9V For Adapter AC 120V/60Hz	Test Mode :	Mode 1

Frequency (MHz)	Reading Level (dBμV)	Correct Factor (dB)	Measure-ment (dBμV)	Limits (dBμV)	Margin (dB)	Remark
0.4168	31.70	9.93	41.63	57.51	15.88	QP
0.4168	24.45	9.93	34.38	47.51	13.13	AVG
0.8304	29.93	9.93	39.86	56.00	16.14	QP
0.8304	22.81	9.93	32.74	46.00	13.26	AVG
1.2485	27.25	9.93	37.18	56.00	18.82	QP
1.2485	20.28	9.93	30.21	46.00	15.79	AVG
1.6624	27.53	9.94	37.47	56.00	18.53	QP
1.6624	20.30	9.94	30.24	46.00	15.76	AVG
3.3279	24.91	9.95	34.86	56.00	21.14	QP
3.3279	15.38	9.95	25.33	46.00	20.67	AVG
5.4184	26.32	9.98	36.30	60.00	23.70	QP
5.4184	17.30	9.98	27.28	50.00	22.72	AVG

Remark:

1. All readings are Quasi-Peak and Average values.
2. Factor = Insertion Loss + Cable Loss.

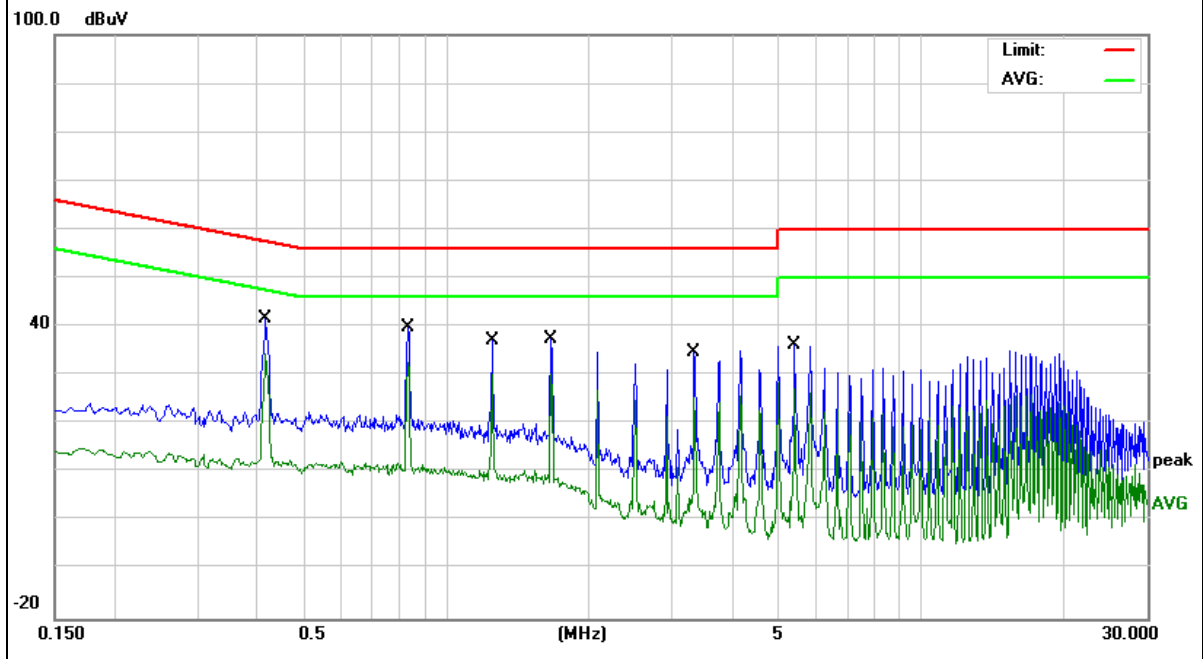

EUT :	Wi-Fi Doorbell	Model Name :	CL-3239
Temperature :	25 °C	Relative Humidity :	55%
Pressure :	1010hPa	Phase :	L
Test Voltage :	AC 9V For Adapter AC 240V/50Hz	Test Mode :	Mode 1

Frequency (MHz)	Reading Level (dBμV)	Correct Factor (dB)	Measure-ment (dBμV)	Limits (dBμV)	Margin (dB)	Remark
0.4179	30.28	9.83	40.11	57.49	17.38	QP
0.4179	22.82	9.83	32.65	47.49	14.84	AVG
0.8339	29.77	9.87	39.64	56.00	16.36	QP
0.8339	22.66	9.87	32.53	46.00	13.47	AVG
1.2500	27.77	9.90	37.67	56.00	18.33	QP
1.2500	20.29	9.90	30.19	46.00	15.81	AVG
3.3380	24.81	10.05	34.86	56.00	21.14	QP
3.3380	15.32	10.05	25.37	46.00	20.63	AVG
5.4218	25.26	10.04	35.30	60.00	24.7	QP
5.4218	15.83	10.04	25.87	50.00	24.13	AVG
15.4379	22.45	10.22	32.67	60.00	27.33	QP
15.4379	12.32	10.22	22.54	50.00	27.46	AVG

Remark:

1. All readings are Quasi-Peak and Average values.
2. Factor = Insertion Loss + Cable Loss.

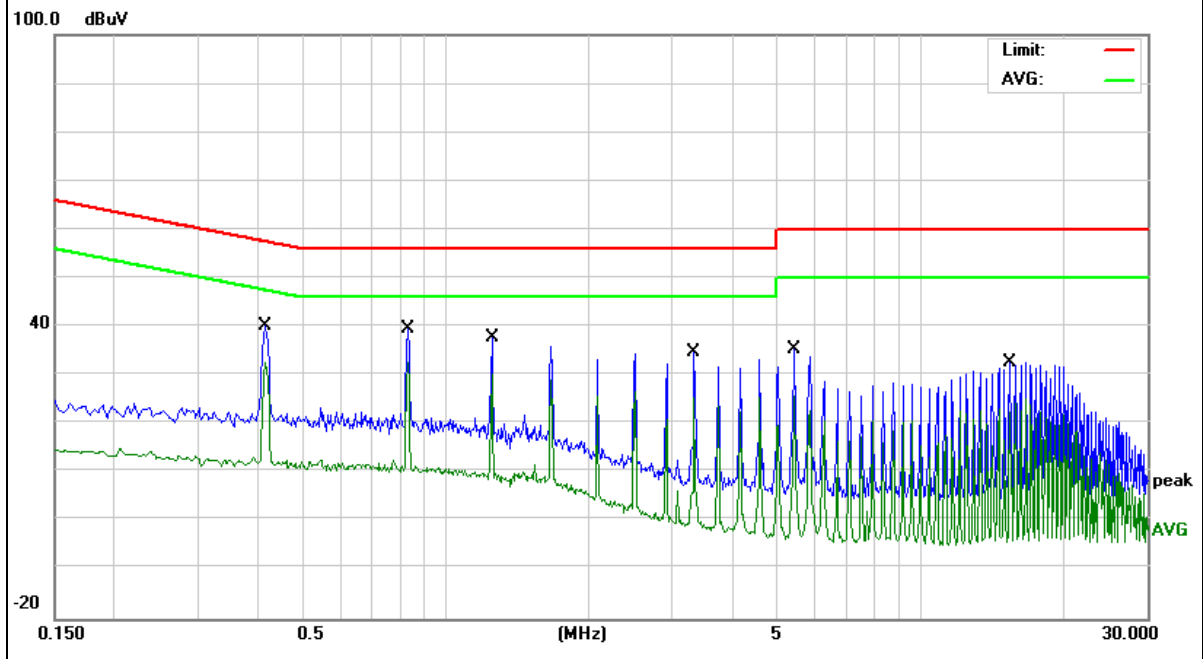

EUT :	Wi-Fi Doorbell	Model Name :	CL-3239
Temperature :	25 °C	Relative Humidity :	55%
Pressure :	1010hPa	Phase :	N
Test Voltage :	AC 9V For Adapter AC 240V/50Hz	Test Mode :	Mode 1

Frequency (MHz)	Reading Level (dBμV)	Correct Factor (dB)	Measure-ment (dBμV)	Limits (dBμV)	Margin (dB)	Remark
0.4178	32.20	9.93	42.13	57.49	15.36	QP
0.4178	24.95	9.93	34.88	47.49	12.61	AVG
0.8338	30.43	9.93	40.36	56.00	15.64	QP
0.8338	23.31	9.93	33.24	46.00	12.76	AVG
1.6698	28.03	9.94	37.97	56.00	18.03	QP
1.6698	20.80	9.94	30.74	46.00	15.26	AVG
4.1779	26.15	9.95	36.10	56.00	19.90	QP
4.1779	16.85	9.95	26.80	46.00	19.20	AVG
5.8498	26.59	10.00	36.59	60.00	23.41	QP
5.8498	16.84	10.00	26.84	50.00	23.16	AVG
17.1057	26.07	10.25	36.32	60.00	23.68	QP
17.1057	16.65	10.25	26.90	50.00	23.10	AVG

Remark:

1. All readings are Quasi-Peak and Average values.
2. Factor = Insertion Loss + Cable Loss.

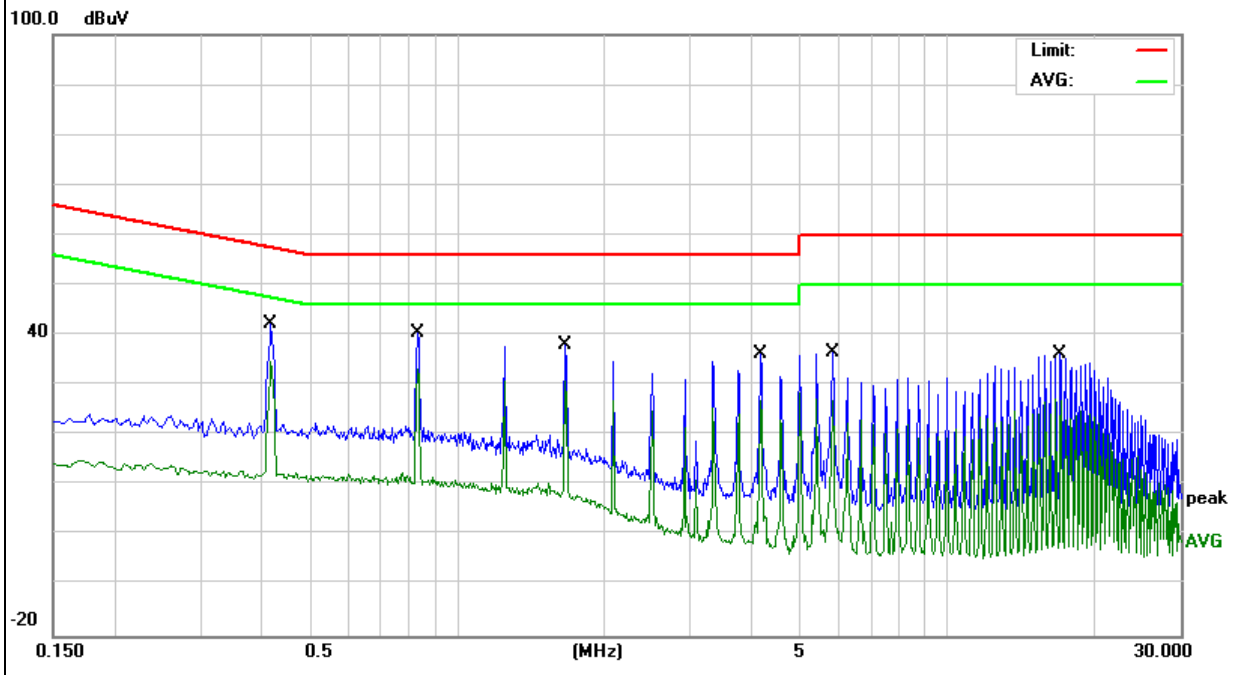

9. RADIATED EMISSION MEASUREMENT

9.1 Applicable Standard

According to 15.209 and ANSI C63.10-2013

9.2 Radiated Emission Limits (FCC 15.209)

Frequencies (MHz)	Field Strength (micorvolts/meter)	Measurement Distance (meters)
0.009~0.490	2400/F(KHz)	300
0.490~1.705	24000/F(KHz)	30
1.705~30.0	30	30
30~88	100	3
88~216	150	3
216~960	200	3
Above 960	500	3

Note:

- (1) The tighter limit applies at the band edges.
- (2) Emission level (dBuV/m)=20log Emission level (uV/m).

LIMITS OF RADIATED EMISSION MEASUREMENT (FCC 15.231)

Fundamental Frequency (MHz)	Field Strength of fundamental (microvolts/meter)	Field Strength of Unwanted Emissions (microvolts/meter)
40.66 - 40.70	2250.00	225.00
70 - 130	950.00	95.00
130 - 174	1,250 to 3,750 **	95 to 375 **
174 - 260	3750.00	375.00
260 - 470	3,750 to 9,500 **	375 to 1,250 **
Above 470	9500.00	950.00

Notes:

- (1) ** linear interpolations

[Where F is the frequency in MHz, the formulas for calculating the maximum permitted fundamental field strengths are as follows: for the band 130-174 MHz, uV/m at 3 meters = 56.81818(F) - 6136.3636; for the band 260-470 MHz, uV/m at 3 meters = 41.6667(F) - 7083.3333. The maximum permitted unwanted emission level is 20 dB below the maximum permitted fundamental level.]

The limits on the field strength of the spurious emissions in the above table are based on the fundamental frequency of the intentional radiator. Spurious emissions shall be attenuated to the average (or, alternatively, CISPR quasi-peak) limits shown in this table or to the general limits shown in 93 Section 15.209, whichever limit permits a higher field strength.

Spectrum Parameter	Setting
Attenuation	Auto
Start Frequency	1000 MHz
Stop Frequency	10th carrier harmonic
RB / VB (emission in restricted band)	1MHz / 1MHz for Peak

Receiver Parameter	Setting
Attenuation	Auto
Start ~ Stop Frequency	9kHz~150kHz / RB 200Hz for QP
Start ~ Stop Frequency	150kHz~30MHz / RB 9kHz for QP
Start ~ Stop Frequency	30MHz~1000MHz / RB 90kHz for QP

9.3 TEST PROCEDURE

The test site semi-anechoic chamber has met the requirement of NSA tolerance 4 dB according to the standards: ANSI C63.10-2013. The test distance is 3m. The setup is according to the requirements in Section 13.1.4.1 of ANSI C63.10-2013 and CAN/CSA-CEI/IEC CISPR 22.

This test is required for any spurious emission that falls in a Restricted Band, as defined in Section 15.205. It must be performed with the highest gain of each type of antenna proposed for use with the EUT.

Use the following spectrum analyzer settings:

Spectrum Parameter	Setting
Attenuation	Auto
Start Frequency	1000 MHz
Stop Frequency	10th carrier harmonic
RB / VB (emission in restricted band)	1 MHz / 1 MHz for Peak, 1 MHz / 10Hz for Average

Receiver Parameter	Setting
Attenuation	Auto
Start ~ Stop Frequency	9kHz~150kHz / RB 200Hz for QP
Start ~ Stop Frequency	150kHz~30MHz / RB 9kHz for QP
Start ~ Stop Frequency	30MHz~1000MHz / RB 120kHz for QP

- a. The measuring distance of at 3 m shall be used for measurements at frequency up to 1GHz. For frequencies above 1GHz, any suitable measuring distance may be used.
- b. The EUT was placed on the top of a rotating table 0.8 m for below 1GHz and 1.5m for above 1GHz the ground at a 3 meter. The table was rotated 360 degrees to determine the position of the highest radiation.
- c. The height of the equipment or of the substitution antenna shall be 0.8 m for below 1GHz and 1.5m for above 1GHz; the height of the test antenna shall vary between 1 m to 4 m. Both horizontal and vertical polarizations of the antenna are set to make the measurement.
- d. For the radiated emission test above 1GHz:
Place the measurement antenna away from each area of the EUT determined to be a source of emissions at the specified measurement distance, while keeping the measurement antenna aimed at the source of emissions at each frequency of significant emissions, with polarization oriented for maximum response. The measurement antenna may have to be higher or lower than the EUT, depending on the radiation pattern of the emission and staying aimed at the emission source for receiving the maximum signal. The final measurement antenna elevation shall be that which maximizes the emissions. The measurement antenna elevation for maximum emissions shall be restricted to a range of heights of from 1 m to 4 m above the ground or reference ground plane.
- e. The initial step in collecting conducted emission data is a spectrum analyzer peak detector mode pre-scanning the measurement frequency range. Significant peaks are then marked and then Quasi Peak detector mode re-measured.
- f. If the Peak Mode measured value compliance with and lower than Quasi Peak Mode Limit, the EUT shall be deemed to meet QP Limits and then no additional QP Mode measurement performed.
- g. For the actual test configuration, please refer to the related Item –EUT Test Photos.

Note:

Both horizontal and vertical antenna polarities were tested and performed pretest to three orthogonal axis. The worst case emissions were reported

During the radiated emission test, the Spectrum Analyzer was set with the following configurations:

Frequency Band (MHz)	Function	Resolution bandwidth	Video Bandwidth
30 to 1000	QP	120 kHz	300 kHz
Above 1000	Peak	1 MHz	1 MHz
	Average	1 MHz	10 Hz

Note: for the frequency ranges below 30 MHz, a narrower RBW is used for these ranges but the measured value should add a RBW correction factor (RBWCF) where $RBWCF [dB] = 10 \cdot \lg(100 [kHz] / \text{narrower RBW [kHz]})$. , the narrower RBW is 1 kHz and RBWCF is 20 dB for the frequency 9 kHz to 150 kHz, and the narrower RBW is 10 kHz and RBWCF is 10 dB for the frequency 150 kHz to 30 MHz.

9.4 TEST SETUP

(A) For radiated emissions below 30MHz

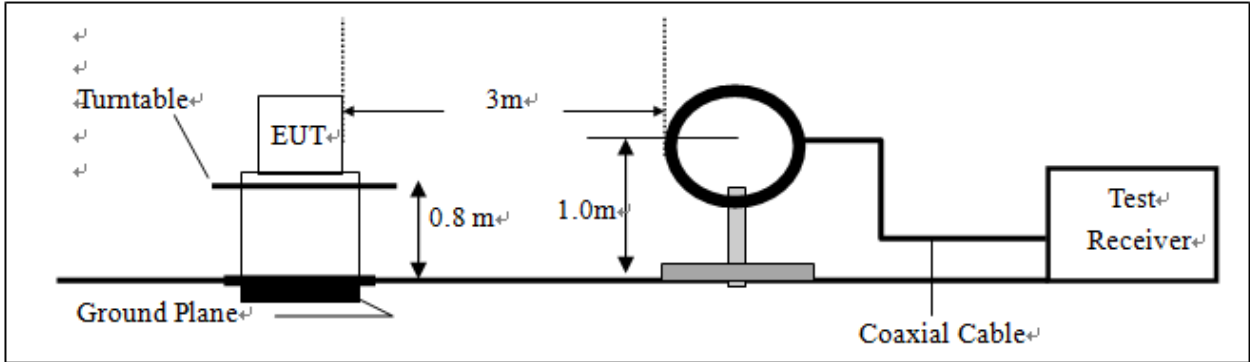

(B) For radiated emissions from 30MHz to 1000MHz

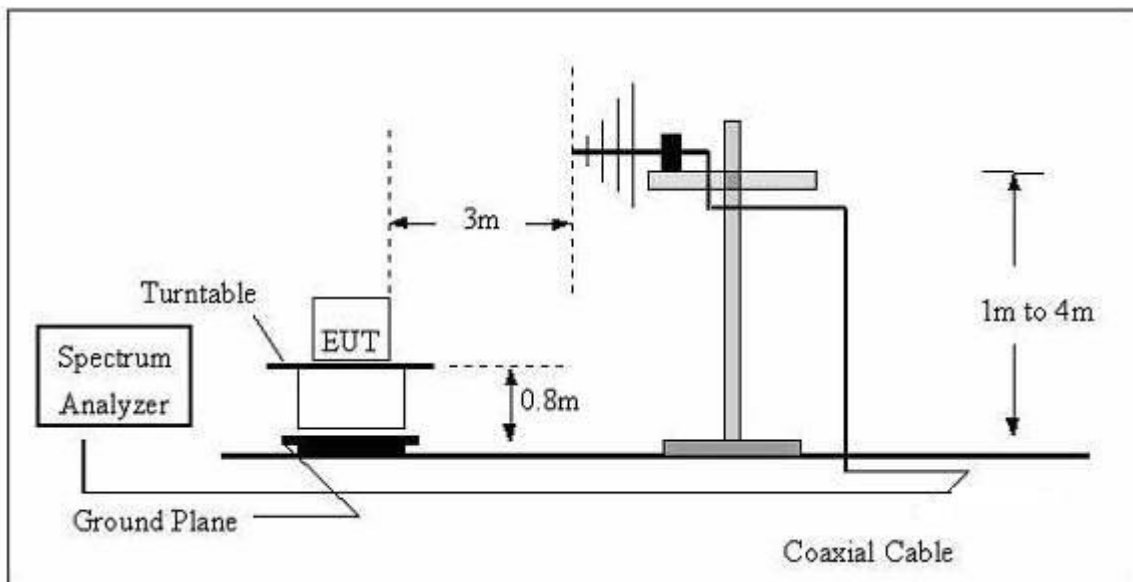

(C) For radiated emissions above 1000MHz

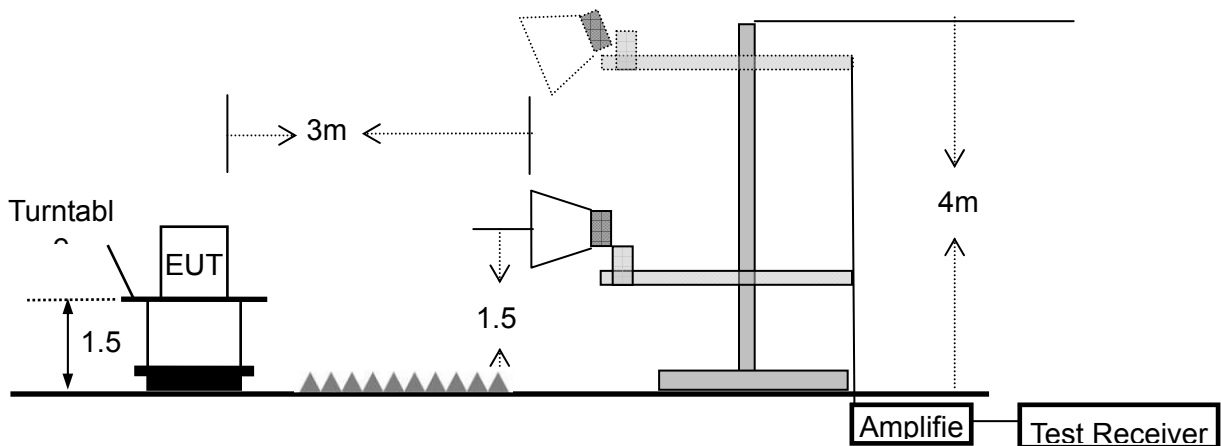

9.5 TEST RESULTS

■ Emission below 30MHz (9KHz to 30MHz)

EUT:	Wi-Fi Doorbell	Model No.:	CL-3239
Temperature:	20 °C	Relative Humidity:	48%
Test Mode:	Mode 1	Test By:	Susan Su

Freq. (MHz)	Ant.Pol. H/V	Emission Level(dBuV/m)		Limit 3m(dBuV/m)		Over(dB)	
		PK	AV	PK	AV	PK	AV
--	--	--	--	--	--	--	--

Note: the amplitude of spurious emission that is attenuated by more than 20dB below the permissible limit has no need to be reported.

Distance extrapolation factor = $20\log(\text{Specific distance/ test distance})$ (dB);

Limit line=Specific limits(dBuV) + distance extrapolation factor

Emission below 1GHz (30MHz to 1GHz)

All the modulation modes have been tested, and the worst result was report as below:

EUT :	Wi-Fi Doorbell	Model Name :	CL-3239
Temperature :	20 °C	Relative Humidity :	48%
Pressure :	1010hPa	Test Mode :	Mode 1
Test Voltage :	DC 3.7V		

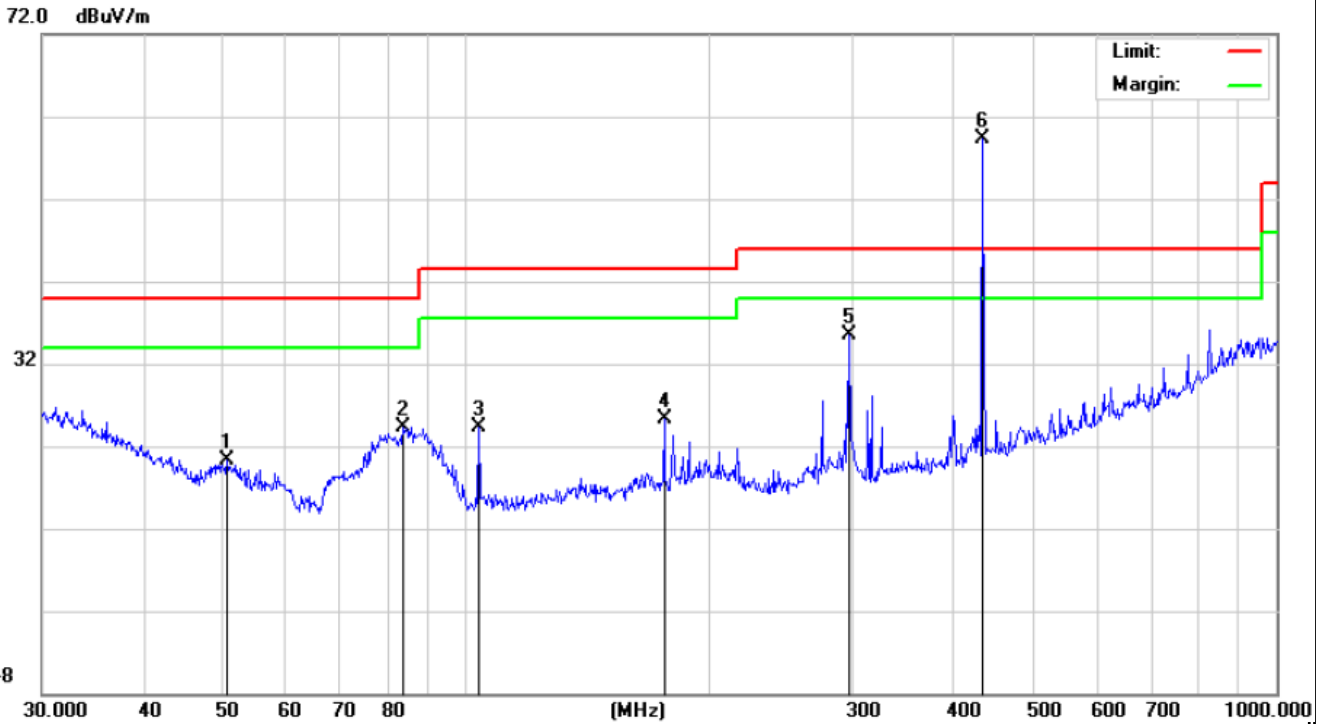

Polar (H/V)	Frequency (MHz)	Reading (dBuV/m)	Correct dB/m	Result (dBuV/m)	Limit (dBuV/m)	Over Limit (dB)	Remark
H	50.7637	6.90	13.31	20.21	40.00	-19.79	QP
H	83.5222	13.08	11.16	24.24	40.00	-15.76	QP
H	103.8055	13.86	10.35	24.21	43.50	-19.29	QP
H	175.6516	12.62	12.65	25.27	43.50	-18.23	QP
H	297.2241	20.82	14.66	35.48	46.00	-10.52	QP
H	433.9254	43.04	16.36	59.40	100.83	-41.43	Peak
H	433.9254	-	-	54.21	80.83	-26.62	AVG

Note: The average value of fundamental frequency is:

Average= Peak Value+ 20log(Duty cycle), Final Average=Peak-5.19

EUT :	Wi-Fi Doorbell	Model Name :	CL-3239
Temperature :	20 °C	Relative Humidity :	48%
Pressure :	1010hPa	Test Mode :	Mode 1
Test Voltage :	DC 3.7V		

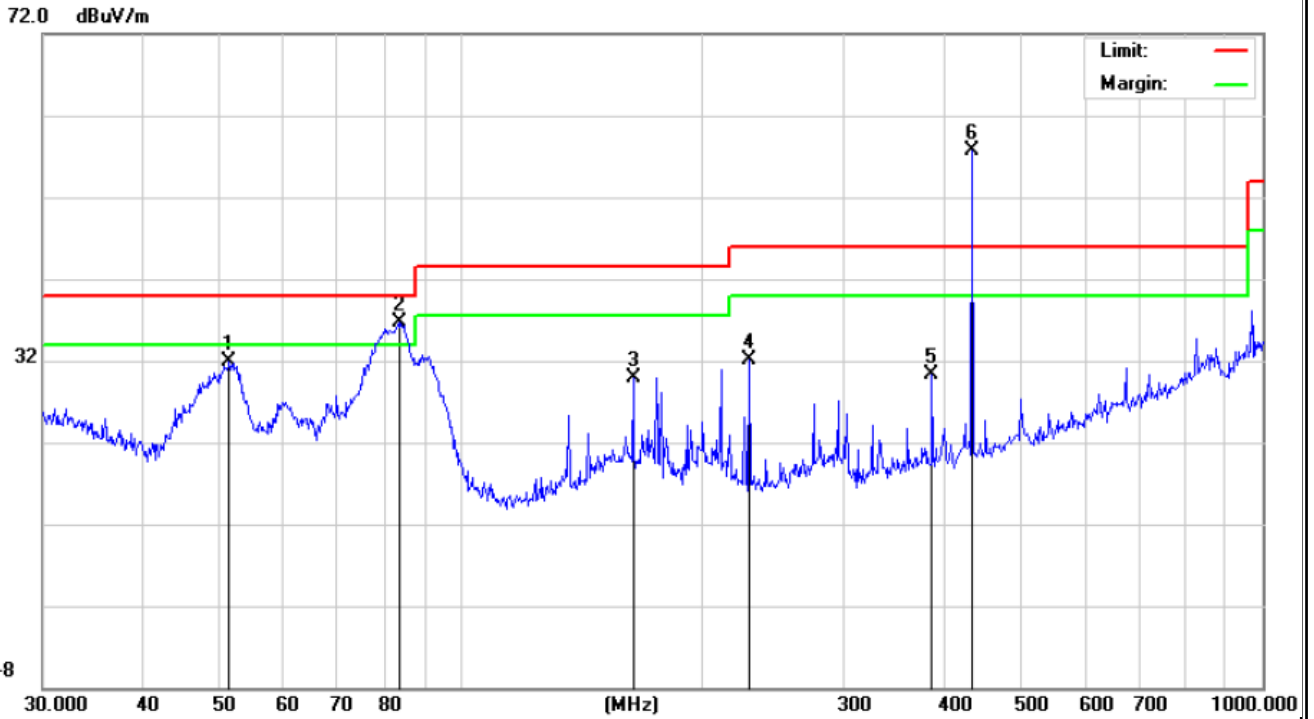

Polar (H/V)	Frequency (MHz)	Reading (dBuV/m)	Correct dB/m	Result (dBuV/m)	Limit (dBuV/m)	Over Limit (dB)	Remark
V	51.3005	18.65	13.29	31.94	40.00	-8.06	QP
V	83.5221	25.53	11.16	36.69	40.00	-3.31	QP
V	163.7550	17.52	12.42	29.94	43.50	-13.56	QP
V	228.4904	19.95	12.10	32.05	46.00	-13.95	QP
V	386.6338	15.29	14.99	30.28	46.00	-15.72	QP
V	433.9215	41.44	16.36	57.80	100.83	-43.03	Peak
V	433.9215			52.61	80.83	-28.22	AVG

Note: The average value of fundamental frequency is:

$$\text{Average} = \text{Peak Value} + 20\log(\text{Duty cycle}), \text{ Final Average} = \text{Peak} - 5.19$$

■ Emission Above 1GHz (1GHz to 25GHz)

EUT :	Wi-Fi Doorbell	Model Name :	CL-3239
Temperature :	20 °C	Relative Humidity :	48%
Pressure :	1010 hPa	Test Voltage :	DC 3.7V
Test Mode :	Mode 1	Polarization :	Horizontal

No.	Frequency	Reading	Correct Factor	Dutycycle Factor	Result	Limit	Over Limit	Remark
	(MHz)	(dBuV/m)	(dB)	(dB)	(dBuV/m)	(dBuV/m)	(dB)	
1	1301.76	24.37	12.41	-	36.78	80.83	-44.05	Peak
2	1735.68	32.40	13.49	-	45.89	80.83	-34.94	Peak
3	2169.6	23.96	16.57	-	40.53	80.83	-40.30	Peak
4	1301.76	-	-	-5.19	31.59	60.83	-29.24	AVG
5	1735.68	-	-	-5.19	40.70	60.83	-20.13	AVG
6	2169.6	-	-	-5.19	35.34	60.83	-25.49	AVG

EUT :	Wi-Fi Doorbell	Model Name :	CL-3239
Temperature :	20 °C	Relative Humidity :	48%
Pressure :	1010 hPa	Test Voltage :	DC 3.7V
Test Mode :	Mode 1	Polarization :	Vertical

No.	Frequency	Reading	Correct Factor	Dutycycle Factor	Result	Limit	Over Limit	Remark
	(MHz)	(dBuV/m)	(dB)	(dB)	(dBuV/m)	(dBuV/m)	(dB)	
1	1301.76	22.15	13.43	-	35.58	80.83	-45.25	Peak
2	1735.68	28.05	13.49	-	41.54	80.83	-39.29	Peak
3	2169.6	20.78	17.91	-	38.69	80.83	-42.14	Peak
4	1301.76	-	-	-5.19	30.39	60.83	-30.44	AVG
5	1735.68	-	-	-5.19	36.35	60.83	-24.48	AVG
6	2169.6	-	-	-5.19	33.50	60.83	-27.33	AVG

Note: 1. EUT Pre-scan X/Y/Z orientation, only worst case is presented in the report(Y orientation).

2. *Calculate Average value based on Duty Cycle correction factor:

$$\text{Duty Cycle} = \text{Ton} / (\text{Ton} + \text{Toff}) = 17.2002\text{ms} / 31.33\text{ms} = 0.55 = 55\%$$

$$\text{Duty Cycle factor} = 20\lg(\text{Duty Cycle}) = 20\lg(0.55) = -5.19\text{dB}$$

$$\text{Average} = \text{Peak} + \text{Duty Cycle factor}$$

$$\begin{aligned} \text{2. FCC Limit for Average Measurement} &= 41.6667(433.92) - 7083.3333 = 10996.681164\mu\text{V/m} \\ &= 80.83\text{dBuV/m} \end{aligned}$$

3. Pulse Desensitization Correction Factor

$$\text{Pulse Width(PW)} = 65.20\text{ms} \quad 2/\text{PW} = 2/65.20\text{ms} = 0.0306\text{kHz}$$

$$\text{RBW}(100\text{kHz}) > 2/\text{PW} (0.02\text{kHz}),$$

Therefore PDCF is not needed.

Duty Cycle:

The duty cycle is simply the on time divided by the period:

The duration of one cycle = 31.33ms

$T_{ON(1\text{ hop})} = 1.2\text{ms}$ $T_{ON(2\text{ hop})} = 0.4667\text{ms}$,

Effective period of the cycle = $1.2\text{ms} * 12 + 0.4667\text{ms} * 6 = 17.2002\text{ms}$,

Duty Cycle = $17.2002\text{ms} / 31.33\text{ms} = 0.55 = 55\%$

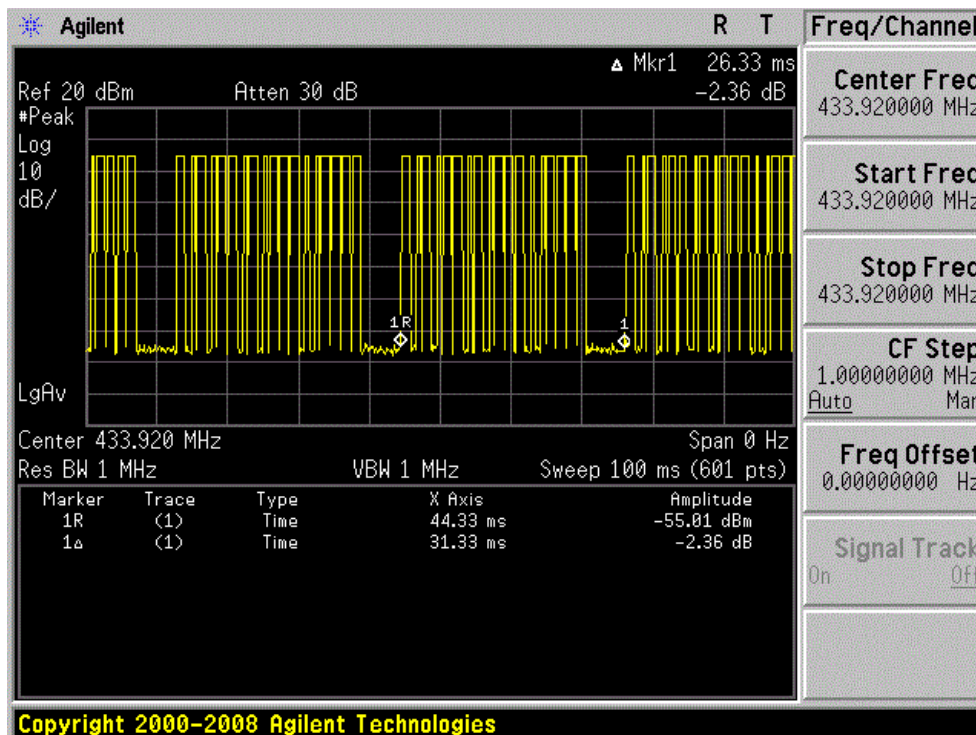
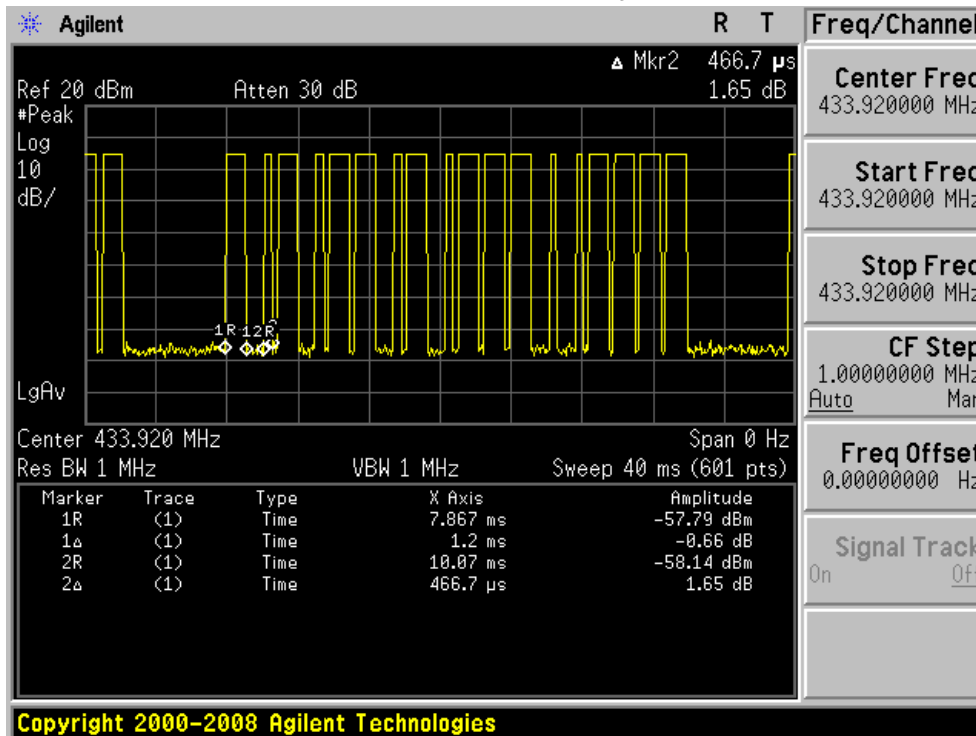
The duration of one cycle

10. BANDWIDTH TEST

10.1 TEST PROCEDURE

The bandwidth of the emission shall be no wider than 0.25% of the center frequency for devices operating above 70 MHz and below 900 MHz. For devices operating above 900 MHz, the emission shall be no wider than 0.5% of the center frequency. Bandwidth is determined at the points 20 dB down from the modulated carrier.

Limit: $433.92\text{MHz} \times 0.25\% = 1084.8\text{KHz}$

10.2 DEVIATION FROM STANDARD

No deviation.

10.3 TEST SETUP

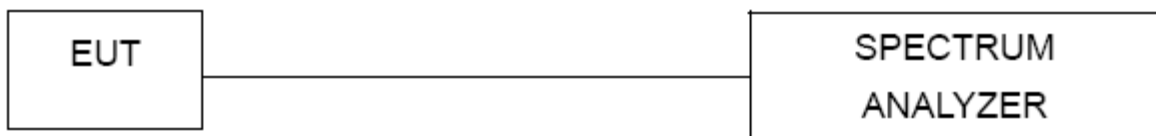

10.4 TEST RESULTS

EUT :	Wi-Fi Doorbell	Model Name :	CL-3239
Temperature :	26 °C	Relative Humidity :	53%
Pressure :	1020 hPa	Test Power :	DC 3.7V
Test Mode :	TX CH 1		

Test Channel	Frequency (MHz)	20 dBc Bandwidth (kHz)	<Limit (kHz)
CH01	433.92	622.847	1084.8



11. TRANSMITTER TIMEOUT

11.1 REQUIREMENTS

1	A manually operated transmitter shall employ a switch that will automatically deactivate the transmitter within not more than 5 seconds of being released. Result: The EUT is a manually activated transmitter, press 5 seconds will automatically stop working
2	A transmitter activated automatically shall cease transmission within 5 seconds after activation. Result: The EUT is a manually activated transmitter, press 5 seconds will automatically stop working
3	Periodic transmissions at regular predetermined intervals are not permitted. However, polling or supervision transmissions, including data, to determine system integrity of transmitters used in security or safety applications are allowed if the total duration of transmissions does not exceed more than two seconds per hour for each transmitter. There is no limit on the number of individual transmissions, provided the total transmission time does not exceed two seconds per hour Result: The EUT does not employ periodic transmission.
4	Intentional radiators which are employed for radio control purposes during emergencies involving fire, security, and safety of life, when activated to signal an alarm, may operate during the pendency of the alarm condition. Result: The section is not applicable to EUT.

Test data

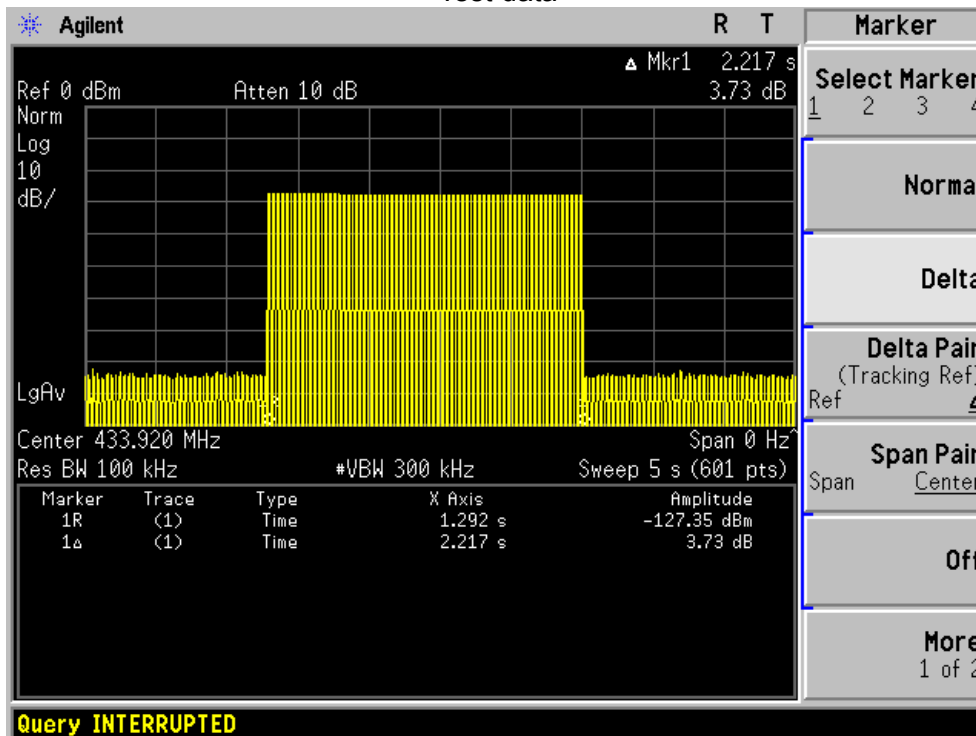

THE DURATION OF EACH TRANSMISSION	LIMIT	RESULT
2.217s	<5s	PASS

END OF REPORT