

ELECTROMAGNETIC EMISSIONS COMPLIANCE REPORT

INTENTIONAL RADIATOR CERTIFICATION TO FCC PART 15 SUBPART C REQUIREMENT AND INDUSTRY CANADA RSS 210

OF

Product Name: CarKit

Brand Name: N/A

Model Name: BT-201

IC Number: 4002A-BT201

ID Number: QMH-BT201

Report No.: EF/2005/20014

Issue Date: Mar. 15, 2005

Rule Part: FCC §15.247, RSS 210, Section 6.2.2(o)

Prepared for Xiamen Xinglian Electronics Co., Ltd.
Xinglian Electronics (Xingtel) Building,
Torch Hi-Tech Industrial District,
Xiamen, China

Prepared by SGS Taiwan Ltd.
No. 134, Wu Kung Rd., Wuku Industrial
Zone, Taipei County, Taiwan.

Note: This report shall not be reproduced except in full, without the written approval of SGS Taiwan Ltd. This document may be altered or revised by SGS Taiwan Ltd. personnel only, and shall be noted in the revision section of the document.

The results shown in this test report refer only to the sample(s) tested unless otherwise stated. This test report cannot be reproduced, except in full, without prior written permission of the Company.

VERIFICATION OF COMPLIANCE

Applicant: Xiamen Xinglian Electronics Co., Ltd
Xinglian Electronics (Xingtel) Building, Torch Hi-Tech Industrial District, Xiamen, China.

Equipment Under Test: CarKit

Brand Name: N/A

IC Number: 4002A-BT201

ID Number: QMH-BT201

Model No.: BT-201

Model Difference: N/A

File Number: EF/2005/20014

Date of test: Feb. 25, 2005 ~ Mar. 14, 2005

Date of EUT Received: Feb. 24, 2005

We hereby certify that:

The above equipment was tested by SGS Taiwan Ltd. The test data, data evaluation, test procedures, and equipment configurations shown in this report were made in accordance with the procedures given in ANSI C63.4 (2003) and the energy emitted by the sample EUT tested as described in this report is in compliance with conducted and radiated emission limits of FCC Rules Part 15.247 and IC RSS 210 section 6.2.2(o).

The test results of this report relate only to the tested sample identified in this report.

Test By: Sky Wang **Date:** Mar. 15, 2005

Sky Wang

Approved By: Vincent Su **Date:** Mar. 15, 2005

Vincent Su

The results shown in this test report refer only to the sample(s) tested unless otherwise stated. This test report cannot be reproduced, except in full, without prior written permission of the Company.

Version

Version No.	Date
00	Mar. 15, 2005

The results shown in this test report refer only to the sample(s) tested unless otherwise stated. This test report cannot be reproduced, except in full, without prior written permission of the Company.

Table of Contents

1. GENERAL INFORMATION	7
1.1 Product Description	7
1.2 Related Submittal(s) / Grant (s)	7
1.3 Test Methodology	7
1.4 Test Facility	7
1.5 Accreditation and Listing	7
1.6 Special Accessories	7
1.7 Equipment Modifications	7
2. SYSTEM TEST CONFIGURATION	8
2.1 EUT Configuration	8
2.2 EUT Exercise	8
2.3 Test Procedure	8
2.4 Configuration of Tested System	9
3. SUMMARY OF TEST RESULTS	10
4. DESCRIPTION OF TEST MODES	10
5. CONDUCTED EMISSION TEST	11
5.1 Standard Applicable	11
5.2 EUT Setup	12
5.3 Measurement Procedure	12
5.4 Measurement Equipment Used:	12
5.5 Measurement Result	12
6. PEAK OUTPUT POWER MEASUREMENT	13
6.1 Standard Applicable	13
6.2 Measurement Procedure	13
6.3 Measurement Result	13
6.4 Measurement Equipment Used:	14
7. 20dB Bandwidth	17
7.1 Standard Applicable	17
7.2 Measurement Procedure	17
7.3 Measurement Result	17
7.4 Measurement Equipment Used:	17

The results shown in this test report refer only to the sample(s) tested unless otherwise stated. This test report cannot be reproduced, except in full, without prior written permission of the Company.

8. 100KHz BANDWIDTH OF BAND EDGES MEASUREMENT.....	20
8.1 Standard Applicable	20
8.2 Measurement Procedure.....	20
8.3 Measurement Result.....	20
8.4 Measurement Equipment Used:.....	20
9. SPURIOUS RADIATED EMISSION TEST.....	24
9.1 Standard Applicable	24
9.2 EUT Setup.....	24
9.3 Measurement Procedure.....	24
9.4 Test SET-UP (Block Diagram of Configuration)	25
9.5 Measurement Equipment Used:.....	26
9.6 Field Strength Calculation	26
9.7 Measurement Result.....	26
10. FREQUENCY SEPARATION.....	45
10.1 Standard Applicable	45
10.2 Measurement Procedure.....	45
10.3 Measurement Result.....	45
10.4 Measurement Equipment Used:.....	45
11. NUMBER OF HOPPING FREQUENCY	47
11.1 Standard Applicable	47
11.2 Measurement Procedure.....	47
11.3 Measurement Result.....	47
11.4 Measurement Equipment Used:.....	47
12. TIME OF OCCUPANCY (DWELL TIME)	49
12.1. Standard Applicable	49
12.2. Measurement Procedure.....	49
12.3. Measurement Result.....	49
12.4. Measurement Equipment Used:.....	50
13. Peak Power Spectral Density	55
13.1. Standard Applicable	55
13.2. Measurement Procedure.....	55
13.3. Measurement Result.....	55
13.4. Measurement Equipment Used:.....	55

The results shown in this test report refer only to the sample(s) tested unless otherwise stated. This test report cannot be reproduced, except in full, without prior written permission of the Company.

14. 99% Bandwidth Measurement	58
14.1. Standard Applicable	58
14.2. Measurement Equipment Used:	58
14.3. Test Set-up:	58
14.4. Measurement Procedure.....	59
14.5. Measurement Result.....	59
15. ANTENNA REQUIREMENT	62
15.1. Standard Applicable	62
15.2. Antenna Connected Construction	62
16. RF EXPOSURE	63
16.1. Standard Applicable	63
16.2. Measurement Result.....	64
APPENDIX 1 PHOTOGRPHS OF SET UP	65
APPENDIX 2 PHOTOGRPHS OF EUT	67

The results shown in this test report refer only to the sample(s) tested unless otherwise stated. This test report cannot be reproduced, except in full, without prior written permission of the Company.

1. GENERAL INFORMATION

1.1 Product Description

The Xiamen Xinglian Electronics Co., Ltd. Model: BT-201 (referred to as the EUT in this report) is CarKit.

A major technical descriptions of EUT is described as following:

- A). Operation Frequency: 2402 – 2480Hz, 79 channels
- B). Rated output power: 2 dBm
- C). Modulation type: Frequency Hopping Spread Spectrum (GFSK)
- D). Antenna Designation: Micro-Strip Antenna, 0.21 dBi, Non-User Replaceable (Fixed)
- E). Power Supply: 12Vdc from Car Battery

1.2 Related Submittal(s) / Grant (s)

This submittal(s) (test report) is intended for FCC ID: QMH-BT201 filing to comply with Section 15.247 of the FCC Part 15, Subpart C Rules. And IC: 4002A-BT201 filing to comply with industry CANADA RSS 210. section 6.2.10

1.3 Test Methodology

Both conducted and radiated testing were performed according to the procedures in ANSI C63.4 (2003). Radiated testing was performed at an antenna to EUT distance 3 meters.

1.4 Test Facility

The open area test site and conducted measurement facility used to collect the radiated data is located on the address of SGS Taiwan Ltd. No. 134, Wu Kung Rd., Wuku Industrial Zone, Taipei Country, Taiwan. The Open Area Test Sites and the Line Conducted labs are constructed and calibrated to meet the FCC requirements in documents ANSI C63.4: 2003 and CISPR 22/EN 55022 requirements.

1.5 Accreditation and Listing

The test facilities used to perform radiated and conducted emissions tests are listed In Canada, Certification and Engineering Bureau, IC4620. for 3m & 10m Open Area Test Site. FCC Site No. 1(3 &10 meters) Registration Number: 94644, Anechoic chamber (3 meters) Registration Number: 573967

1.6 Special Accessories

Not available for this EUT intended for grant.

1.7 Equipment Modifications

Not available for this EUT intended for grant.

The results shown in this test report refer only to the sample(s) tested unless otherwise stated. This test report cannot be reproduced, except in full, without prior written permission of the Company.

2. SYSTEM TEST CONFIGURATION

2.1 EUT Configuration

The EUT configuration for testing is installed on RF field strength measurement to meet the Commissions requirement and operating in a manner which intends to maximize its emission characteristics in a continuous normal application.

2.2 EUT Exercise

The EUT (Transmitter) was operated in the engineering mode to fix the Tx frequency that was for the purpose of the measurements.

2.3 Test Procedure

2.3.1 Conducted Emissions

The EUT is a placed on as turn table which is 0.8 m above ground plane. According to the requirements in Section 7, 13 of ANSI C63.4-2003. Conducted emissions from the EUT measured in the frequency range between 0.15 MHz and 30MHz using CISPR Quasi-Peak and Average detector mode.

2.3.2 Radiated Emissions

The EUT is a placed on as turn table which is 0.8 m above ground plane. The turn table shall rotate 360 degrees to determine the position of maximum emission level. EUT is set 3m away from the receiving antenna which varied from 1m to 4m to find out the highest emission. And also, each emission was to be maximized by changing the polarization of receiving antenna both horizontal and vertical. In order to find out the max. emission, the relative positions of this hand-held transmitter(EUT) was rotated through three orthogonal axes according to the requirements in Section 8, 13 of ANSI C63.4-2003.

The results shown in this test report refer only to the sample(s) tested unless otherwise stated. This test report cannot be reproduced, except in full, without prior written permission of the Company.

2.4 Configuration of Tested System

Fig. 2-1 Configuration of Tested System

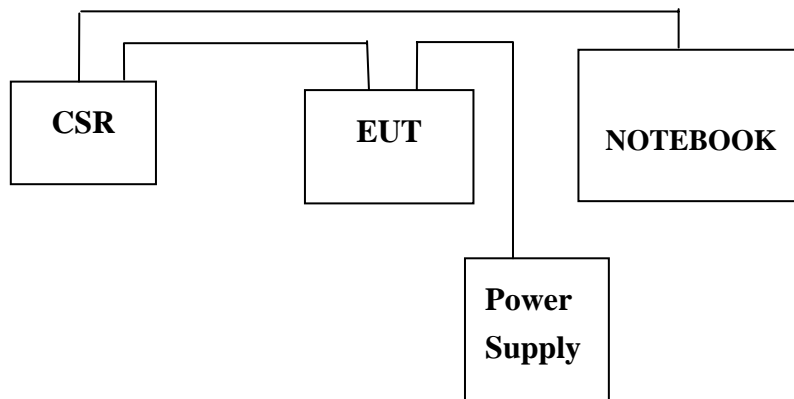

Table 2-1 Equipment Used in Tested System

Item	Equipment	Mfr/Brand	Model/ Type No.	FCC ID	Series No.	Data Cable	Power Cord
1.	Notebook	IBM	T2367	DOC	99GLD64	N/A	Un-shield
2.	BT development kit	CSR/CASIRA	BCES301199	DOC	7383-07-04-03	N/A	Un-shield
3.	DC Power Supply	Topward	3303A	715844	DC Power Supply	N/A	Un-shield

The results shown in this test report refer only to the sample(s) tested unless otherwise stated. This test report cannot be reproduced, except in full, without prior written permission of the Company.

3. SUMMARY OF TEST RESULTS

FCC Rules	Description Of Test	Result
§15.207(a)/ §6.6	Conducted Emission	N/A
§15.247(b)/ §6.2.2(o)(a3)	Peak Output Power	Compliant
§6.2.2(o)(a3)	20dB Bandwidth	Compliant
§15.247(c) §6.2.2(o)(e1)	100 KHz Bandwidth Of Frequency Band Edges	Compliant
§15.247(c) §6.2.2(o)(e1)	Spurious Emission	Compliant
§15.247(a)(1) §6.2.2(o)(a1)	Frequency Separation	Compliant
§15.247(a)(1)(iii) §6.2.2(o)(a3)	Number of hopping frequency	Compliant
§15.247(a)(1)(ii) §6.2.2(o)(a3)	Time of Occupancy	Compliant
§15.247	Peak Power Density	Compliant
§15.203 §5.5	Antenna Requirement	Compliant
§1.1310	RF Exposure	Compliant
§5.9.1	99% Power Bandwidth	Compliant

4. DESCRIPTION OF TEST MODES

The EUT (Bluetooth GPS Receiver) has been tested under operating condition.

Test program used to control the EUT for staying in continuous transmitting and receiving mode is programmed.

Channel low (2402MHz)、mid (2441MHz) and high (2480MHz) with 741k highest data rate are chosen for full testing.

The results shown in this test report refer only to the sample(s) tested unless otherwise stated. This test report cannot be reproduced, except in full, without prior written permission of the Company.

5. CONDUCTED EMISSION TEST

5.1 Standard Applicable

According to §15.207. frequency within 150KHz to 30MHz shall not exceed the Limit table as below.

Frequency range MHz	Limits dB(uV)	
	Quasi-peak	Average
0.15 to 0.50	66 to 56	56 to 46
0.50 to 5	56	46
5 to 30	60	50

Note

- 1.The lower limit shall apply at the transition frequencies
- 2.The limit decreases linearly with the logarithm of the frequency in the range 0.15 MHz to 0.50 MHz.

According to section RSS 210, section 6.6 Transmitter AC Wireline Conducted Emissions. Limits is as following.

Frequency range MHz	Limits dB (uV)
	Average
0.45 to 30	48

Note:

1. if the level of the emission measured using the quasi-peak instrumentation is 6 dB, or more, higher than the level of the same emission measured with instrumentation having an average detector and a 9 kHz minimum bandwidth, that emission is considered broadband and the level obtained with the quasi-peak detector may be reduced by 13 dB for comparison to the limits.

The results shown in this test report refer only to the sample(s) tested unless otherwise stated. This test report cannot be reproduced, except in full, without prior written permission of the Company.

5.2 EUT Setup

1. The conducted emission tests were performed in the test site, using the setup in accordance with the ANSI C63.4-2003.
2. The AC/DC Power adaptor of EUT was plug-in LISN. The rear of the EUT and peripherals were placed flushed with the rear of the tabletop.
3. The LISN was connected with 110Vac/60Hz power source.

5.3 Measurement Procedure

1. The EUT was placed on a table which is 0.8m above ground plane.
2. Maximum procedure was performed on the six highest emissions to ensure EUT compliance.
3. Repeat above procedures until all frequency measured were complete.

5.4 Measurement Equipment Used:

Conducted Emission Test Site					
EQUIPMENT TYPE	MFR	MODEL NUMBER	SERIAL NUMBER	LAST CAL.	CAL DUE.
EMC Analyzer	HP	8594EM	3624A00203	12/31/2004	12/30/2005
EMI Test Receiver	R&S	ESCS30	828985/004	01/15/2004	01/14/2006
LISN	Rolf-Heine	NNB-2/16Z	99012	12/30/2004	12/29/2005
LISN	Rolf-Heine	NNB-2/16Z	99013	11/06/2004	11/05/2005

5.5 Measurement Result

N/A. The EUT is power from 12V Battery.

The initial step in collecting conducted data is a spectrum analyzer peak scan of the measurement range. Significant peaks are then marked as shown on the following data page, and these signals are then quasi-peaked.

The results shown in this test report refer only to the sample(s) tested unless otherwise stated. This test report cannot be reproduced, except in full, without prior written permission of the Company.

6. PEAK OUTPUT POWER MEASUREMENT

6.1 Standard Applicable

According to §15.247(b), For frequency hopping systems operating in the 2400-2483.5 MHz band employing at least 75 hopping channels, and all frequency hopping systems in the 5725-5850MHz band: 1Watt. For all other frequency hopping systems in the 2400 – 2483.5MHz band: 0.125 Watts.

According to §6.2.2(o)(a3), For frequency hopping systems operating in the 2400-2483.5 MHz band employing at least 75 hopping channels, the transmitter output power shall not exceed 1.0Watt. For all other frequency hopping systems in the 2400 – 2483.5MHz band the transmitter output power shall not exceed 0.125 Watts.

6.2 Measurement Procedure

1. Place the EUT on the table and set it in transmitting mode.
2. Remove the antenna from the EUT and then connect a low loss RF cable from the antenna port to the power meter or spectrum. (Channel power function, RBW, VBW = 1MHz)
3. Record the max. reading.
4. Repeat above procedures until all frequency measured were complete.

6.3 Measurement Result

CH	Frequency (MHz)	Reading Power dBm	Cable Loss	Output Power dBm	Output Power W	Limit (W)
LOW	2402.00	0.87	0.20	1.07	0.00128	1
MID	2441.00	1.31	0.20	1.51	0.00142	1
HIGH	2480.00	1.63	0.20	1.83	0.00152	1

The results shown in this test report refer only to the sample(s) tested unless otherwise stated. This test report cannot be reproduced, except in full, without prior written permission of the Company.

6.4 Measurement Equipment Used:

EQUIPMENT TYPE	MFR	MODEL NUMBER	SERIAL NUMBER	LAST CAL.	CAL DUE.
Spectrum Analyzer	R&S	FSP 40	100034	05/27/2004	05/26/2005
Spectrum Analyzer	Agilent	E7405A	US41160416	08/27/2004	08/27/2005
Low Loss Cable	HUBER+SUHNER	SUCOFLEX 104PEA	N/A	N/A	N/A
Attenuator	Mini-Circult	BW-S6W5	N/A	10/07/2004	10/06/2005

The results shown in this test report refer only to the sample(s) tested unless otherwise stated. This test report cannot be reproduced, except in full, without prior written permission of the Company.

Peak Power Output Data Plot (CH Low)

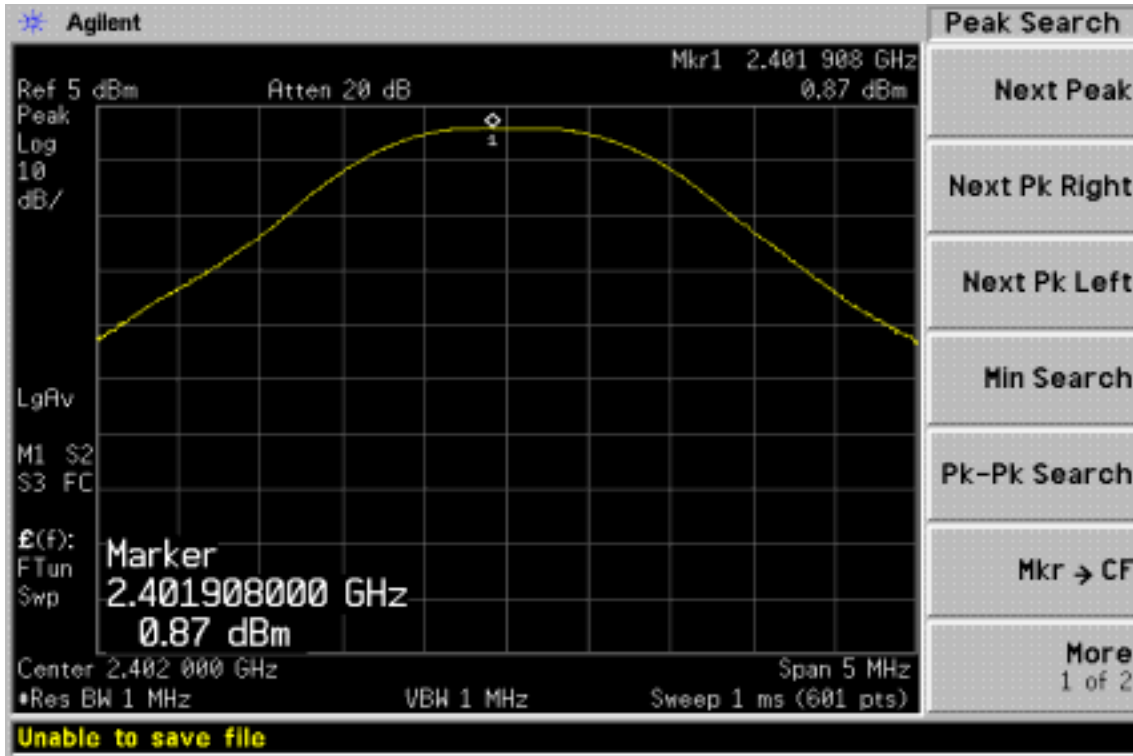

Peak Power Output Data Plot (CH Mid)

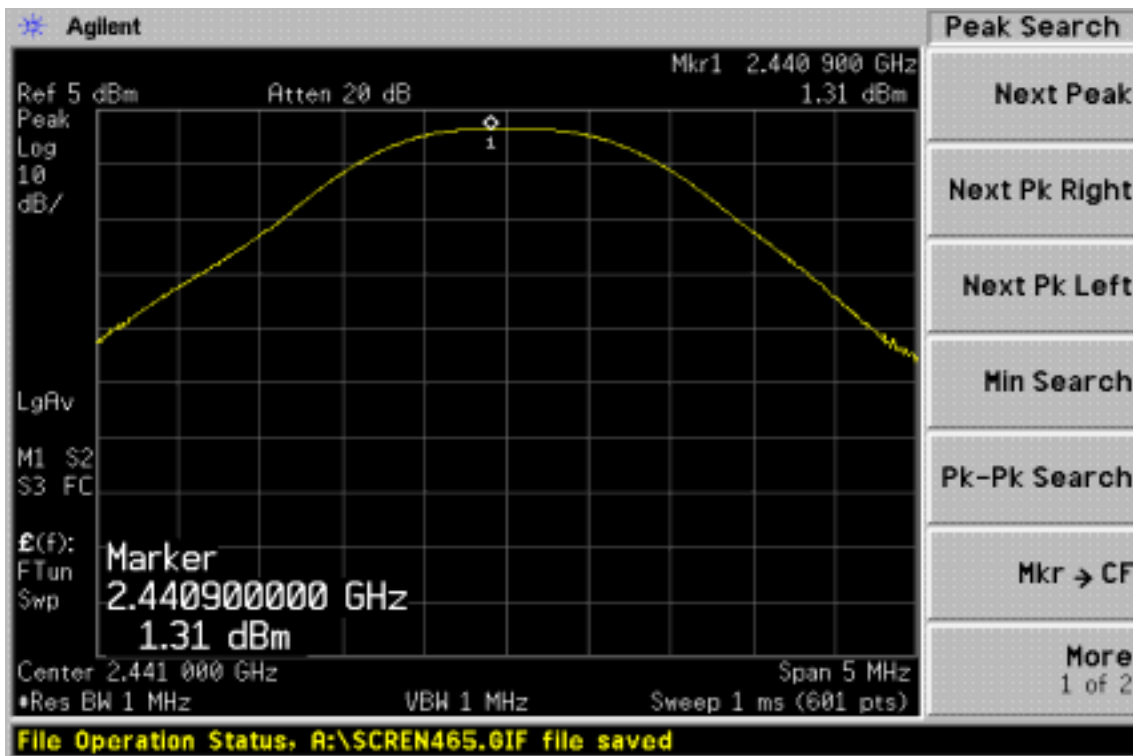

The results shown in this test report refer only to the sample(s) tested unless otherwise stated. This test report cannot be reproduced, except in full, without prior written permission of the Company.

Peak Power Output Data Plot (CH High)

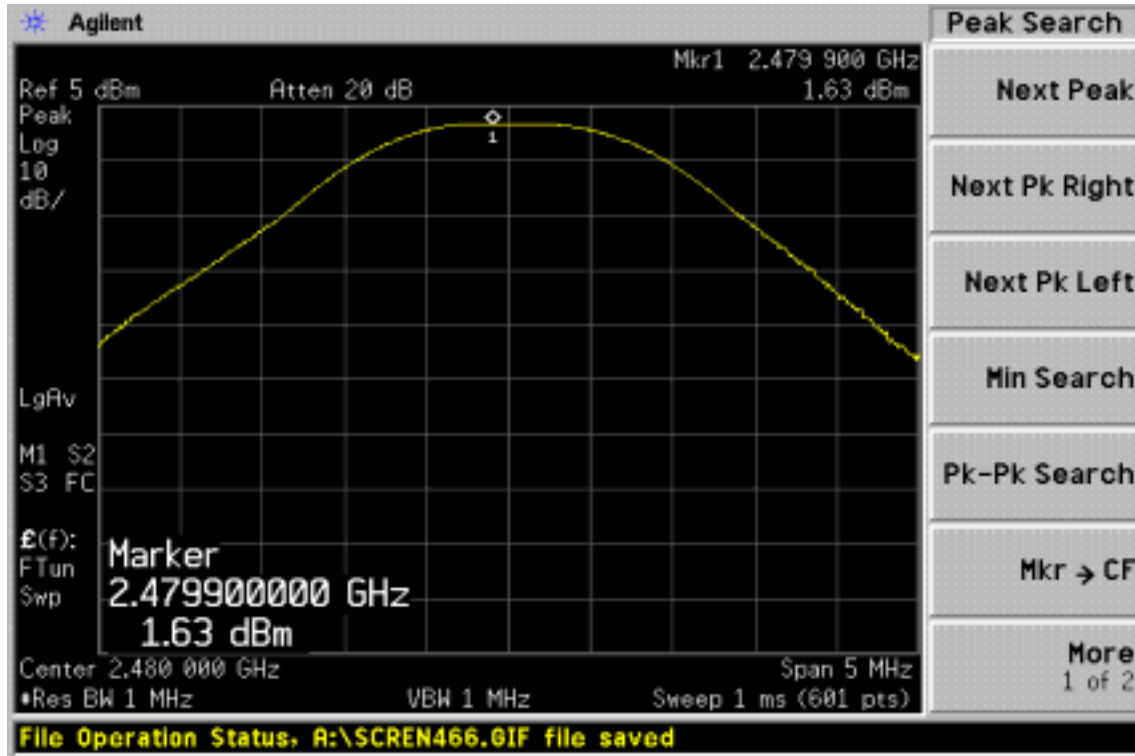

The results shown in this test report refer only to the sample(s) tested unless otherwise stated. This test report cannot be reproduced, except in full, without prior written permission of the Company.

7. 20dB Bandwidth

7.1 Standard Applicable

For frequency hopping systems operating in the 2400MHz-2483.5 MHz no limit for 20dB bandwidth.

According to RSS 210, §6.2.2(o)(a3), For frequency hopping systems operating in the 2400MHz-2483.5 MHz The maximum 20 dB bandwidth of the hopping channel shall be 1 MHz.

7.2 Measurement Procedure

1. Place the EUT on the table and set it in transmitting mode.
2. Remove the antenna from the EUT and then connect a low loss RF cable from the antenna port to the spectrum analyzer.
3. Set the spectrum analyzer as RBW=10KHz (1 % of Bandwidth.), Span= 2MHz, Sweep=auto
4. Mark the peak frequency and -20dB (upper and lower) frequency.
5. Repeat above procedures until all frequency measured were complete.

7.3 Measurement Result

CH	Bandwidth (MHz)	Limit (MHz)
Lower	0.750	1
Mid	0.795	1
Higher	0.950	1

7.4 Measurement Equipment Used:

EQUIPMENT TYPE	MFR	MODEL NUMBER	SERIAL NUMBER	LAST CAL.	CAL DUE.
Spectrum Analyzer	R&S	FSP 40	100034	05/27/2004	05/26/2005
Spectrum Analyzer	Agilent	E7405A	US41160416	08/27/2004	08/27/2005
Low Loss Cable	HUBER+SUHNER	SUCOFLEX 104PEA	N/A	N/A	N/A
Attenuator	Mini-Circult	BW-S6W5	N/A	10/07/2004	10/06/2005

The results shown in this test report refer only to the sample(s) tested unless otherwise stated. This test report cannot be reproduced, except in full, without prior written permission of the Company.

20dB Band Width Test Data CH-Low

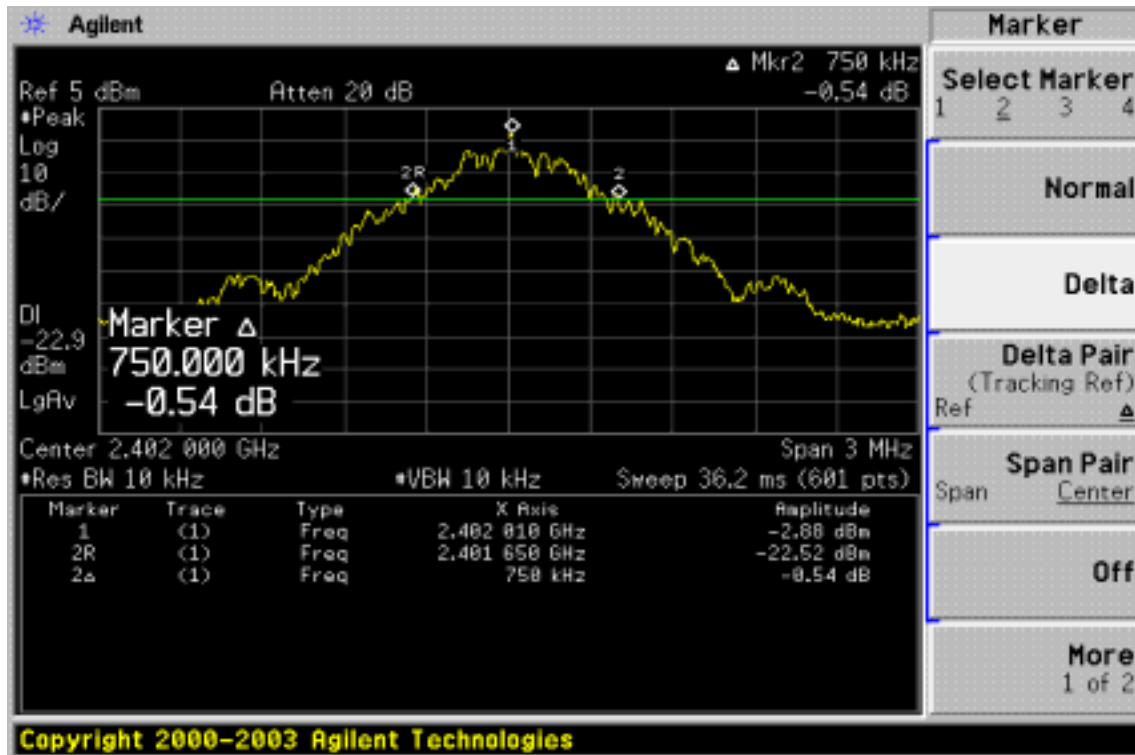

20dB Band Width Test Data CH-Mid

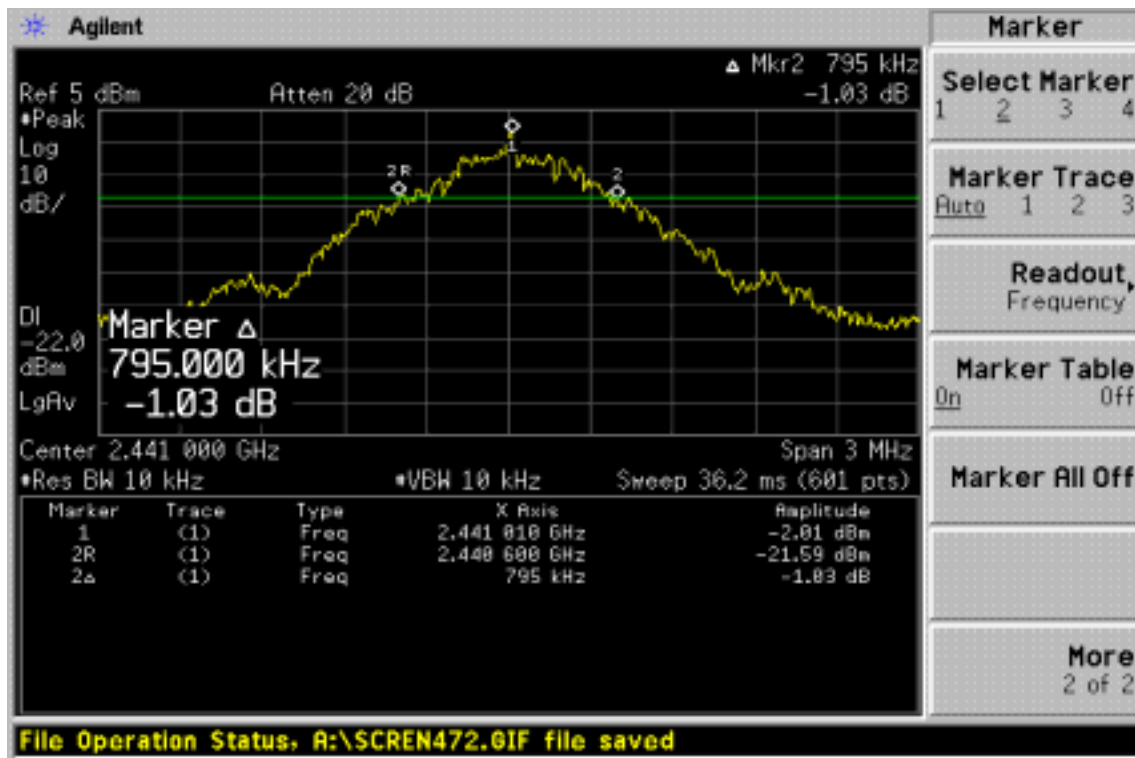

The results shown in this test report refer only to the sample(s) tested unless otherwise stated. This test report cannot be reproduced, except in full, without prior written permission of the Company.

20dB Band Width Test Data CH-High

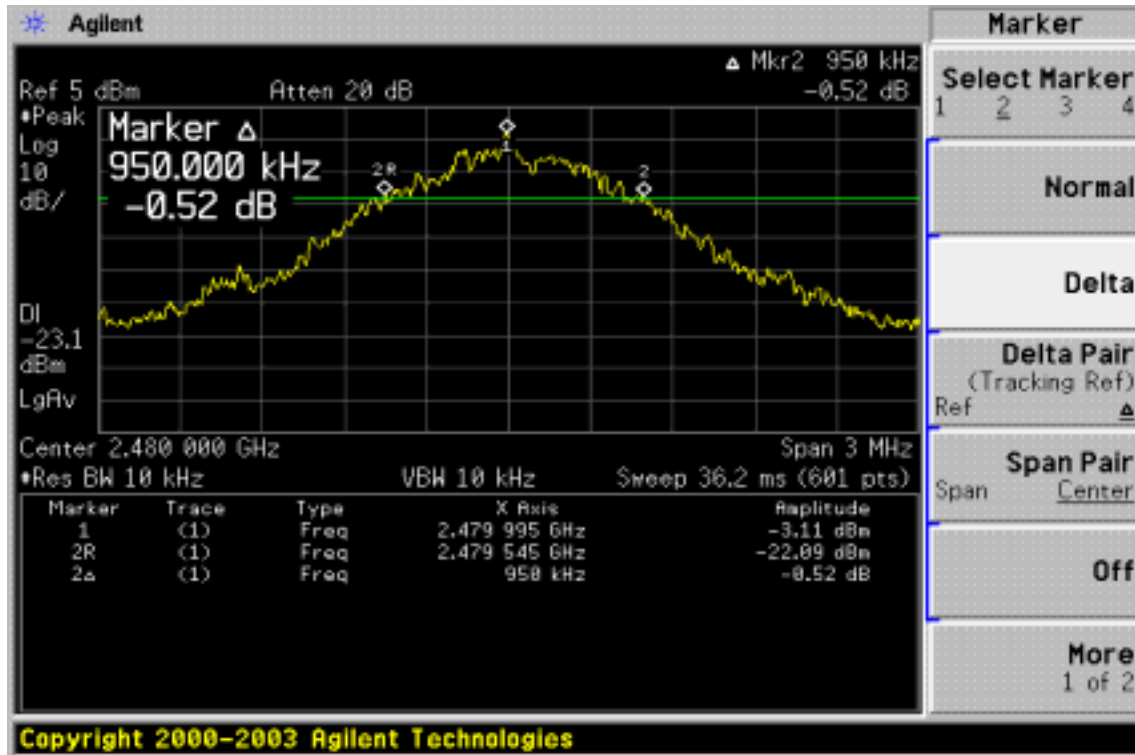

The results shown in this test report refer only to the sample(s) tested unless otherwise stated. This test report cannot be reproduced, except in full, without prior written permission of the Company.

8. 100KHz BANDWIDTH OF BAND EDGES MEASUREMENT

8.1 Standard Applicable

According to §15.247(c), in any 100 KHz bandwidth outside the frequency bands in which the spread spectrum intentional radiator is operating, the radio frequency power that is produced by the intentional radiator shall be at least 20dB below that in the 100KHz bandwidth within the band that contains the highest level of the desired power, In addition, radiated emissions which fall in the restricted bands, as defined in §15.205(a), must also comply with the radiated emission limits specified in 15.209(a).

According to §6.2.2(o)(e1), In any 100 kHz bandwidth outside the operating frequency bands, between 30 MHz and 5 times the carrier frequency, the unwanted emission spectral density shall be either at least 20 dB below the inband spectral density, or shall not exceed the levels specified in Table 3, whichever is less stringent.

8.2 Measurement Procedure

1. Place the EUT on the table and set it in transmitting mode.
2. Remove the antenna from the EUT and then connect a low loss RF cable from the antenna port to the spectrum analyzer.
3. Set center frequency of spectrum analyzer = operating frequency.
4. Set the spectrum analyzer as RBW, VBW=100KHz, Span=25MHz, Sweep = auto
5. Mark Peak, 2.390GHz and 2.488GHz and record the max. level.
6. Repeat above procedures until all frequency measured were complete.

8.3 Measurement Result

Refer to attach spectrum analyzer data chart.

8.4 Measurement Equipment Used:

EQUIPMENT TYPE	MFR	MODEL NUMBER	SERIAL NUMBER	LAST CAL.	CAL DUE.
Spectrum Analyzer	R&S	FSP 40	100034	05/27/2004	05/26/2005
Spectrum Analyzer	Agilent	E7405A	US41160416	08/27/2004	08/27/2005
Low Loss Cable	HUBER+SUHNER	SUCOFLEX 104PEA	N/A	N/A	N/A
Attenuator	Mini-Circult	BW-S6W5	N/A	10/07/2004	10/06/2005

The results shown in this test report refer only to the sample(s) tested unless otherwise stated. This test report cannot be reproduced, except in full, without prior written permission of the Company.

Band Edges Test Data CH-Low

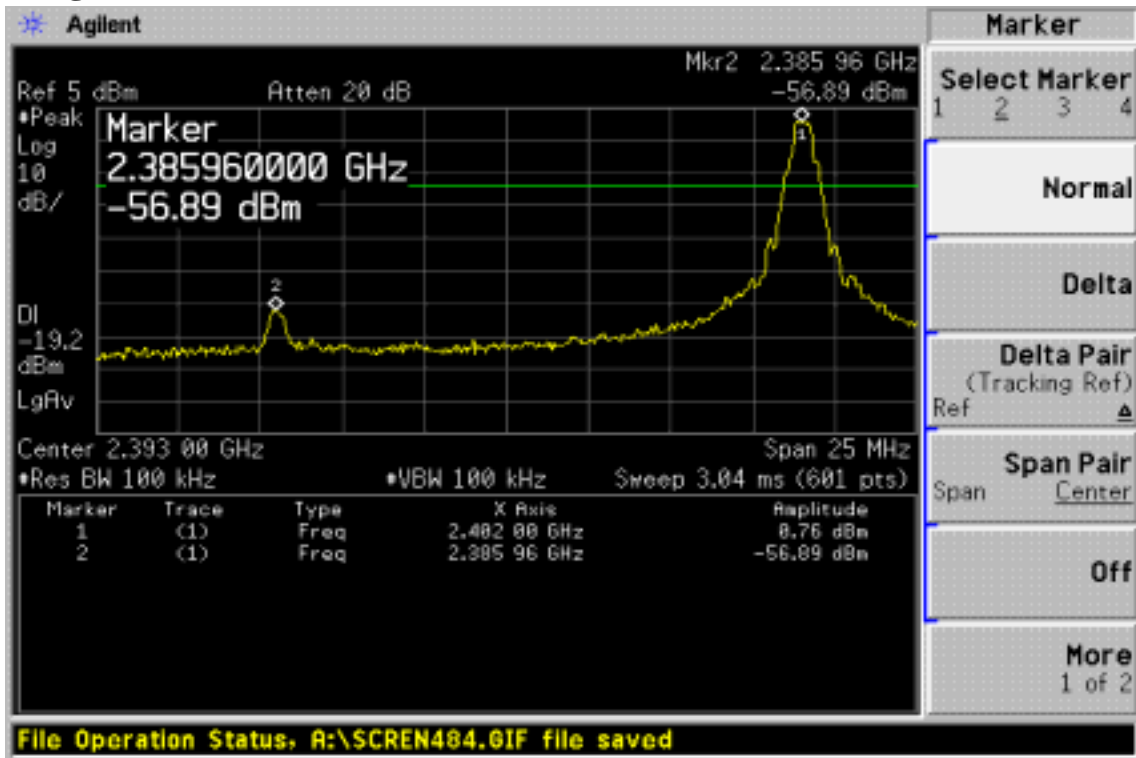

Band Edges Test Data CH-High

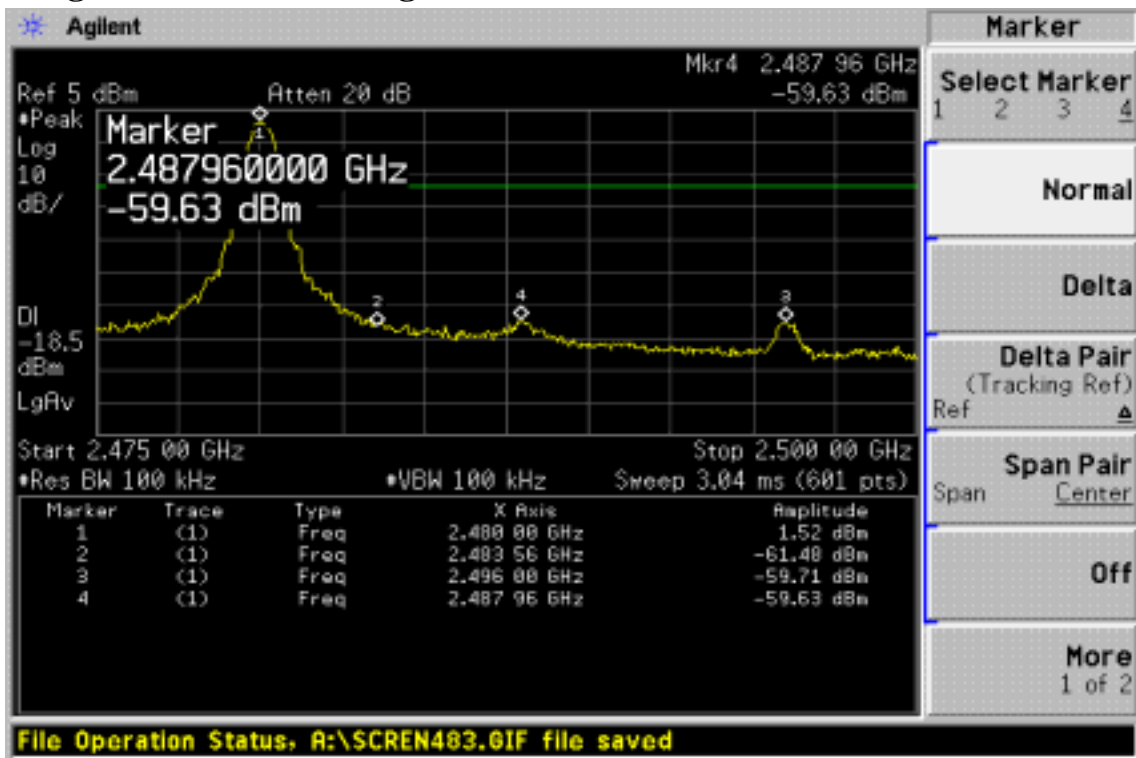

The results shown in this test report refer only to the sample(s) tested unless otherwise stated. This test report cannot be reproduced, except in full, without prior written permission of the Company.

Radiated Emission:

Operation Mode	TX CH Low	Test Date	Mar. 07, 2005
Fundamental Frequency	2402 MHz	Test By	Sky
Temperature	23	Pol	Ver.
Humidity	54 %		

Freq. (MHz)	Peak	AV	Actual FS Ant./CL CF(dB)	Peak	AV	Peak Limit (dBuV/m)	AV	Margin (dB)	Remark
	Reading (dBuV)	Reading (dBuV)		Peak (dBuV/m)	AV (dBuV/m)		Limit (dBuV/m)		
2385.96		---				74.00	54.00		Peak

Operation Mode	TX CH Low	Test Date	Mar. 07, 2005
Fundamental Frequency	2402 MHz	Test By	Sky
Temperature	23	Pol	Hor.
Humidity	54 %		

Freq. (MHz)	Peak	AV	Actual FS Ant./CL CF(dB)	Peak	AV	Peak Limit (dBuV/m)	AV	Margin (dB)	Remark
	Reading (dBuV)	Reading (dBuV)		Peak (dBuV/m)	AV (dBuV/m)		Limit (dBuV/m)		
2385.96		---				74.00	54.00		Peak

Remark :

- (1) Datas of measurement within this frequency range shown “ - ” in the table above means the reading of emissions are attenuated more than 20dB below the permissible limits or the field strength is too small to be measured.
- (2) Radiated emissions measured in frequency above 1000MHz were made with an instrument using Peak detector mode and average detector mode of the emission shown in Actual FS column.
- (3) Spectrum Peak Setting : 1GHz- 26GHz, RBW= 1MHz, VBW= 3MHz, Sweep time= 200 ms.
- (4) Spectrum AV Setting : 1GHz- 26GHz, RBW= 1MHz, VBW= 10Hz, Sweep time= 200 ms.

The results shown in this test report refer only to the sample(s) tested unless otherwise stated. This test report cannot be reproduced, except in full, without prior written permission of the Company.

Radiated Emission:

Operation Mode	TX CH High	Test Date	Mar. 07, 2005
Fundamental Frequency	2480 MHz	Test By	Sky
Temperature	23	Pol	Ver.
Humidity	54 %		

Freq. (MHz)	Peak	AV	Ant./CL CF(dB)	Actual FS		Peak	AV	Margin (dB)	Remark
	Reading (dBuV)	Reading (dBuV)		Peak (dBuV/m)	AV (dBuV/m)	Limit (dBuV/m)	Limit (dBuV/m)		
2483.56		---			---	74.00	54.00		Peak
2487.96									

Operation Mode	TX CH High	Test Date	Mar. 07, 2005
Fundamental Frequency	2480 MHz	Test By	Sky
Temperature	23	Pol	Hor.
Humidity	54 %		

Freq. (MHz)	Peak	AV	Ant./CL CF(dB)	Actual FS		Peak	AV	Margin (dB)	Remark
	Reading (dBuV)	Reading (dBuV)		Peak (dBuV/m)	AV (dBuV/m)	Limit (dBuV/m)	Limit (dBuV/m)		
2483.56		---			---	74.00	54.00		Peak
2487.96									

Remark :

- (1) Datas of measurement within this frequency range shown “ - ” in the table above means the reading of emissions are attenuated more than 20dB below the permissible limits or the field strength is too small to be measured.
- (2) Radiated emissions measured in frequency above 1000MHz were made with an instrument using Peak detector mode and average detector mode of the emission shown in Actual FS column.
- (3) Spectrum Peak Setting: 1GHz- 26GHz, RBW= 1MHz, VBW= 3MHz, Sweep time= 200 ms.
- (4) Spectrum AV Setting: 1GHz- 26GHz, RBW= 1MHz, VBW= 10Hz, Sweep time= 200 ms.

The results shown in this test report refer only to the sample(s) tested unless otherwise stated. This test report cannot be reproduced, except in full, without prior written permission of the Company.

9. SPURIOUS RADIATED EMISSION TEST

9.1 Standard Applicable

According to §15.247(c), all other emissions outside these bands shall not exceed the general radiated emission limits specified in §15.209(a). And according to §15.33(a)(1), for an intentional radiator operates below 10GHz, the frequency range of measurements: to the tenth harmonic of the highest fundamental frequency or to 40GHz, whichever is lower.

According to §6.2.2(o)(e1), In any 100 kHz bandwidth outside the operating frequency bands, between 30 MHz and 5 times the carrier frequency, the unwanted emission spectral density shall be either at least 20 dB below the inband spectral density, or shall not exceed the levels specified in Table 3, whichever is less stringent.

9.2 EUT Setup

1. The radiated emission tests were performed in the 3 meter open-test site, using the setup in accordance with the ANSI C63.4-2003.
2. The EUT was put in the front of the test table. The rear of the EUT and peripherals were placed flushed with the rear of the tabletop.
3. The spacing between the peripherals was 10 centimeters.
4. External I/O cables were draped along the edge of the test table and bundle when necessary.

9.3 Measurement Procedure

1. The EUT was placed on a turn table which is 0.8m above ground plane.
2. The turn table shall rotate 360 degrees to determine the position of maximum emission level.
3. EUT is set 3m away from the receiving antenna which varied from 1m to 4m to find out the highest emissions.
4. Maximum procedure was performed on the six highest emissions to ensure EUT compliance.
5. And also, each emission was to be maximized by changing the polarization of receiving antenna both horizontal and vertical.
6. Repeat above procedures until all frequency measured were complete.

The results shown in this test report refer only to the sample(s) tested unless otherwise stated. This test report cannot be reproduced, except in full, without prior written permission of the Company.

9.4 Test SET-UP (Block Diagram of Configuration)

(A) Radiated Emission Test Set-Up, Frequency Below 1000MHz

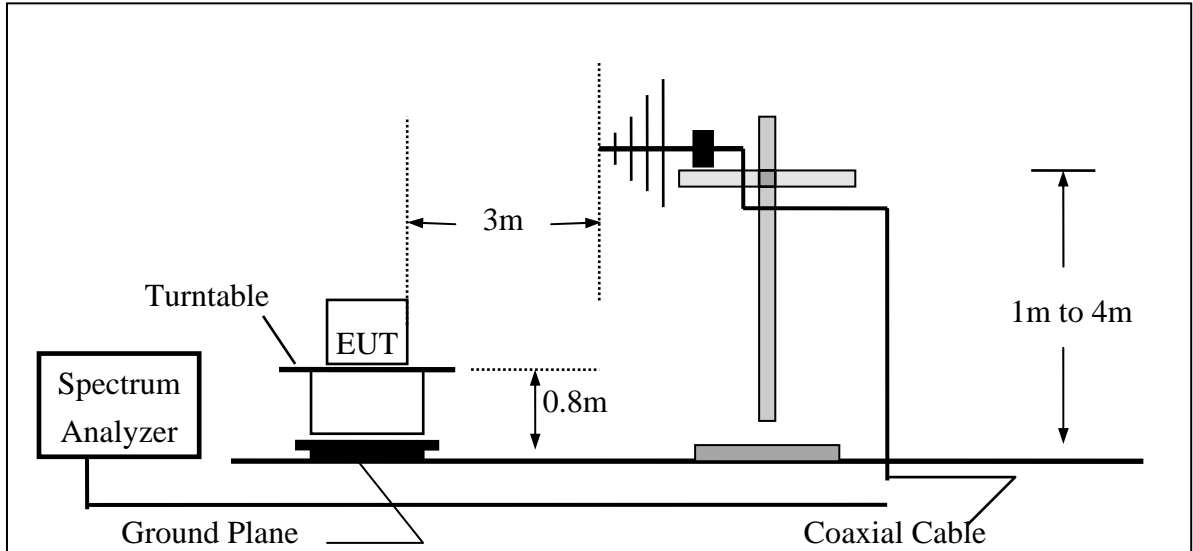

(B) Radiated Emission Test Set-UP Frequency Over 1 GHz

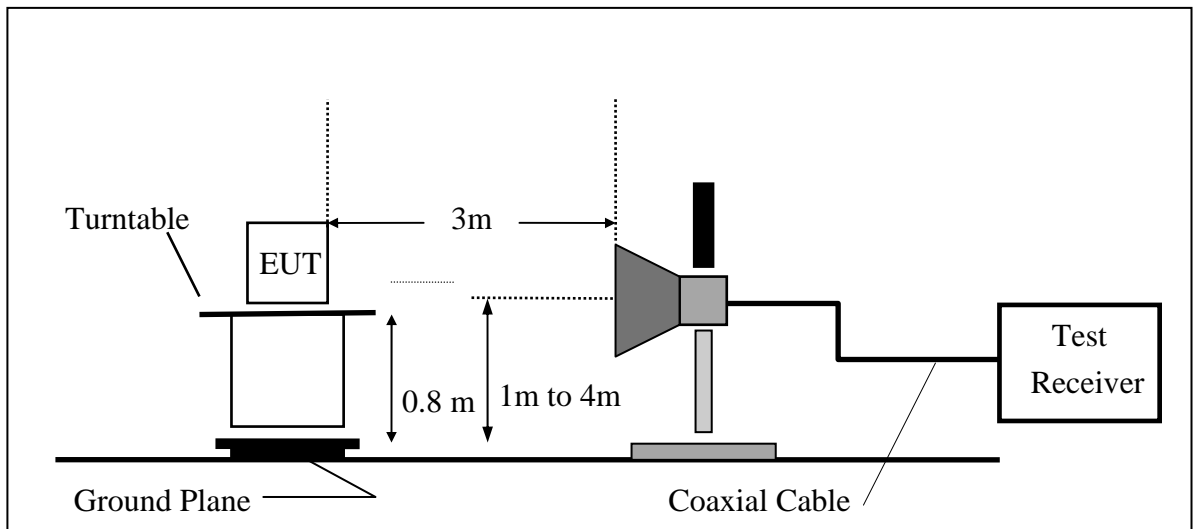

The results shown in this test report refer only to the sample(s) tested unless otherwise stated. This test report cannot be reproduced, except in full, without prior written permission of the Company.

9.5 Measurement Equipment Used:

966 Chamber					
EQUIPMENT TYPE	MFR	MODEL NUMBER	SERIAL NUMBER	LAST CAL.	CAL DUE.
Spectrum Analyzer	R&S	FSP 40	100034	05/27/2004	05/26/2005
Spectrum Analyzer	Agilent	E7405A	US41160416	08/27/2004	08/27/2005
Bilog Antenna	SCHWAZBECK	VULB9163	152	06/03/2004	06/02/2005
Horn antenna	Schwarzbeck	BBHA 9120D	309/320	08/16/2004	08/15/2005
Horn antenna	Schwarzbeck	BBHA 9170	184/185	07/04/2004	07/03/2005
Pre-Amplifier	HP	8447D	2944A09469	07/19/2004	07/18/2005
Pre-Amplifier	HP	8494B	3008A00578	02/26/2004	02/25/2006
Turn Table	HD	DT420	N/A	N.C.R	N.C.R
Antenna Tower	HD	MA240-N	240/657	N.C.R	N.C.R
Controller	HD	HD100	N/A	N.C.R	N.C.R
Low Loss Cable	HUBER+SUHNER	SUCOFLEX 104PEA-10M	10m	10/09/2004	10/08/2005
Low Loss Cable	HUBER+SUHNER	SUCOFLEX 104PEA-3M	3m	10/09/2004	10/08/2005
Site NSA	SGS	966 chamber	N/A	11/17/2004	11/16/2005

9.6 Field Strength Calculation

The field strength is calculated by adding the Antenna Factor and Cable Factor and subtracting the Amplifier Gain and Duty Cycle Correction Factor(if any) from the measured reading. The basic equation with a sample calculation is as follows:

$$FS = RA + AF + CL - AG$$

Where	FS = Field Strength	CL = Cable Attenuation Factor (Cable Loss)
	RA = Reading Amplitude	AG = Amplifier Gain
	AF = Antenna Factor	

9.7 Measurement Result

Refer to attach tabular data sheets.

The results shown in this test report refer only to the sample(s) tested unless otherwise stated. This test report cannot be reproduced, except in full, without prior written permission of the Company.

Radiated Spurious Emission Measurement Result (below 1GHz)

Operation Mode	TX CH Low	Test Date	Mar. 07, 2005
Fundamental Frequency	2402MHz	Test By	Sky
Temperature	25	Pol	Ver./Hor
Humidity	60 %		

Freq. (MHz)	Ant.Pol. H/V	Detector Mode (PK/QP)	Reading (dBuV)	Factor (dB)	Actual FS (dBuV/m)	Limit3m (dBuV/m)	Safe Margin (dB)
96.93	V	Peak	50.60	-14.91	35.69	43.50	-7.81
167.74	V	Peak	46.44	-17.07	29.37	43.50	-14.13
300.63	V	Peak	45.74	-16.00	29.74	46.00	-16.26
499.48	V	Peak	42.76	-14.12	28.64	46.00	-17.36
567.38	V	Peak	42.09	-14.77	27.32	46.00	-18.68
701.24	V	Peak	37.38	-10.58	26.80	46.00	-19.20
97.90	H	Peak	52.40	-14.91	37.49	43.50	-6.01
300.63	H	Peak	46.39	-16.00	30.39	46.00	-15.61
500.45	H	Peak	44.04	-14.12	29.92	46.00	-16.08
599.39	H	Peak	41.44	-14.69	26.75	46.00	-19.25
749.74	H	Peak	37.30	-10.58	26.72	46.00	-19.28
865.17	H	Peak	37.80	-9.50	28.30	46.00	-17.70

Remark :

- (1) Measuring frequencies from 30 MHz to the 1GHz.
- (2) Radiated emissions measured in frequency range from 30 MHz to 1000MHz were made with an instrument using Peak/QP detector mode.
- (3) Datas of measurement within this frequency range shown “ - ” in the table above means the reading of emissions are attenuated more than 20dB below the permissible limits or the field strength is too small to be measured.
- (4) The IF bandwidth of SPA between 30MHz to 1GHz was 100KHz.

The results shown in this test report refer only to the sample(s) tested unless otherwise stated. This test report cannot be reproduced, except in full, without prior written permission of the Company.

Radiated Spurious Emission Measurement Result (below 1GHz)

Operation Mode	TX CH Mid	Test Date	Mar. 07, 2005
Fundamental Frequency	2441MHz	Test By	Sky
Temperature	23	Pol	Ver./Hor
Humidity	54 %		

Freq. (MHz)	Ant.Pol. H/V	Detector Mode (PK/QP)	Reading (dBuV)	Factor (dB)	Actual FS (dBuV/m)	Limit3m (dBuV/m)	Safe Margin (dB)
64.92	V	Peak	48.41	-14.67	33.74	40.00	-6.26
128.94	V	Peak	48.71	-14.91	33.80	43.50	-9.70
300.63	V	Peak	45.74	-17.07	28.67	46.00	-17.33
499.48	V	Peak	41.71	-16.00	25.71	46.00	-20.29
533.43	V	Peak	39.53	-14.12	25.41	46.00	-20.59
567.38	V	Peak	37.51	-10.66	26.85	46.00	-19.15
128.94	H	Peak	48.68	-14.91	33.77	43.50	-9.73
300.63	H	Peak	46.73	-16.00	30.73	46.00	-15.27
465.53	H	Peak	42.72	-14.12	28.60	46.00	-17.40
533.43	H	Peak	43.56	-14.77	28.79	46.00	-17.21
600.36	H	Peak	40.88	-10.58	30.30	46.00	-15.70
866.14	H	Peak	39.56	-9.50	30.06	46.00	-15.94

Remark :

- (1) Measuring frequencies from 30 MHz to the 1GHz.
- (2) Radiated emissions measured in frequency range from 30 MHz to 1000MHz were made with an instrument using Peak/QP detector mode.
- (3) Datas of measurement within this frequency range shown “ - ” in the table above means the reading of emissions are attenuated more than 20dB below the permissible limits or the field strength is too small to be measured.
- (4) The IF bandwidth of SPA between 30MHz to 1GHz was 100KHz.

The results shown in this test report refer only to the sample(s) tested unless otherwise stated. This test report cannot be reproduced, except in full, without prior written permission of the Company.

Radiated Spurious Emission Measurement Result (below 1GHz)

Operation Mode	TX CH High	Test Date	Mar. 07, 2005
Fundamental Frequency	2480MHz	Test By	Sky
Temperature	23	Pol	Ver./Hor
Humidity	54 %		

Freq. (MHz)	Ant.Pol. H/V	Detector Mode (PK/QP)	Reading (dBuV)	Factor (dB)	Actual FS (dBuV/m)	Limit3m (dBuV/m)	Safe Margin (dB)
65.89	V	Peak	48.41	-14.67	33.74	40.00	-6.26
128.94	V	Peak	49.17	-14.91	34.26	43.50	-9.24
300.63	V	Peak	45.76	-16.00	29.76	46.00	-16.24
499.48	V	Peak	41.15	-14.12	27.03	46.00	-18.97
533.43	V	Peak	39.48	-14.77	24.71	46.00	-21.29
567.38	V	Peak	38.64	-10.58	28.06	46.00	-17.94
99.84	H	Peak	52.33	-14.91	37.42	43.50	-6.08
300.63	H	Peak	46.88	-16.00	30.88	46.00	-15.12
533.43	H	Peak	42.74	-14.12	28.62	46.00	-17.38
600.36	H	Peak	40.73	-16.49	24.24	46.00	-21.76
749.74	H	Peak	38.17	-14.77	23.40	46.00	-22.60
900.09	H	Peak	36.60	-10.58	26.02	46.00	-19.98

Remark :

- (1) Measuring frequencies from 30 MHz to the 1GHz.
- (2) Radiated emissions measured in frequency range from 30 MHz to 1000MHz were made with an instrument using Peak/QP detector mode.
- (3) Datas of measurement within this frequency range shown “ - ” in the table above means the reading of emissions are attenuated more than 20dB below the permissible limits or the field strength is too small to be measured.
- (4) The IF bandwidth of SPA between 30MHz to 1GHz was 100KHz.
- (5) X Mode means the EUT in stand-up position; Y Mode means the EUT in lie-on position

The results shown in this test report refer only to the sample(s) tested unless otherwise stated. This test report cannot be reproduced, except in full, without prior written permission of the Company.

Radiated Spurious Emission Measurement Result (above 1GHz)

Operation Mode	TX CH Low	Test Date	Mar. 07, 2005
Fundamental Frequency	2402 MHz	Test By	Sky
Temperature	23	Pol	Ver.
Humidity	54 %		

Freq. (MHz)	Peak	AV	Ant./CL CF(dB)	Actual FS		Peak	AV	Margin (dB)
	Reading (dBuV)	Reading (dBuV)		Peak (dBuV/m)	AV (dBuV/m)	Limit (dBuV/m)	Limit (dBuV/m)	
1598.0	42.72	--	-6.81	35.91	--	74.00	54.00	-18.09
4796.0	42.76	--	2.95	45.71	--	74.00	54.00	-8.29
7149.5	41.86	--	9.25	51.11	--	74.00	54.00	-2.89
7206.0	----							
9608.0	----							
12010.0	----							
14412.0	----							
16814.0	----							
19216.0	----							
21618.0	----							
24020.0	----							

Remark :

- (1) Measuring frequencies scanned from 1GHz to the 10th harmonic of highest fundamental frequency.
- (2) Datas of measurement within this frequency range shown “ - ” in the table above means the reading of emissions are attenuated more than 20dB below the permissible limits or the field strength is too small to be measured.
- (3) Radiated emissions measured in frequency above 1000MHz were made with an instrument using Peak detector mode and average detector mode of the emission shown in Actual FS column.
- (4) Spectrum Peak Setting : 1GHz- 26GHz, RBW= 1MHz, VBW= 3MHz, Sweep time= 200 ms.
- (5) Spectrum AV Setting : 1GHz- 26GHz, RBW= 1MHz, VBW= 10Hz, Sweep time= 200 ms.

The results shown in this test report refer only to the sample(s) tested unless otherwise stated. This test report cannot be reproduced, except in full, without prior written permission of the Company.

Radiated Spurious Emission Measurement Result (above 1GHz)

Operation Mode	TX CH Low	Test Date	Mar. 07, 2005
Fundamental Frequency	2402 MHz	Test By	Sky
Temperature	23	Pol	Hor
Humidity	54 %		

Freq. (MHz)	Peak	AV	Ant./CL CF(dB)	Actual FS		Peak	AV	Margin (dB)
	Reading (dBuV)	Reading (dBuV)		Peak (dBuV/m)	AV (dBuV/m)	Limit (dBuV/m)	Limit (dBuV/m)	
1598.0	42.72	--	-6.81	35.91	--	74.00	54.00	-18.09
4796.0	42.73	--	2.95	45.68	--	74.00	54.00	-8.32
7194.5	43.60	--	9.25	52.85	--	74.00	54.00	-1.15
14388.0	----							
19184.0	----							
23980.0	----							
28776.0	----							
33572.0	----							
38368.0	----							
43164.0	----							
47960.0	----							

Remark :

- (1) Measuring frequencies scanned from 1GHz to the 10th harmonic of highest fundamental frequency.
- (2) Datas of measurement within this frequency range shown “ - ” in the table above means the reading of emissions are attenuated more than 20dB below the permissible limits or the field strength is too small to be measured.
- (3) Radiated emissions measured in frequency above 1000MHz were made with an instrument using Peak detector mode and average detector mode of the emission shown in Actual FS column.
- (4) Spectrum Peak Setting : 1GHz- 26GHz, RBW= 1MHz, VBW= 3MHz, Sweep time= 200 ms.
- (5) Spectrum AV Setting : 1GHz- 26GHz, RBW= 1MHz, VBW= 10Hz, Sweep time= 200 ms.

The results shown in this test report refer only to the sample(s) tested unless otherwise stated. This test report cannot be reproduced, except in full, without prior written permission of the Company.

Radiated Spurious Emission Measurement Result (above 1GHz)

Operation Mode	TX CH Mid	Test Date	Mar. 07, 2005
Fundamental Frequency	2441 MHz	Test By	Sky
Temperature	23	Pol	Ver
Humidity	54 %		

Freq. (MHz)	Peak	AV	Ant./CL CF(dB)	Actual FS		Peak	AV	Margin (dB)
	Reading (dBuV)	Reading (dBuV)		Peak (dBuV/m)	AV (dBuV/m)	Limit (dBuV/m)	Limit (dBuV/m)	
1598.0	41.49	--	-6.81	34.68	--	74.00	54.00	-19.32
4880.5	38.61	--	3.18	41.79	--	74.00	54.00	-12.21
7305.0	40.57	--	9.44	50.01	--	74.00	54.00	-3.99
7323.0	----							
9764.0	----							
12205.0	----							
14646.0	----							
17087.0	----							
19528.0	----							
21969.0	----							
24410.0	----							

Remark :

- (1) Measuring frequencies scanned from 1GHz to the 10th harmonic of highest fundamental frequency.
- (2) Datas of measurement within this frequency range shown “ - ” in the table above means the reading of emissions are attenuated more than 20dB below the permissible limits or the field strength is too small to be measured.
- (3) Radiated emissions measured in frequency above 1000MHz were made with an instrument using Peak detector mode and average detector mode of the emission shown in Actual FS column.
- (4) Spectrum Peak Setting : 1GHz- 26GHz, RBW= 1MHz, VBW= 3MHz, Sweep time= 200 ms.
- (5) Spectrum AV Setting : 1GHz- 26GHz, RBW= 1MHz, VBW= 10Hz, Sweep time= 200 ms.

The results shown in this test report refer only to the sample(s) tested unless otherwise stated. This test report cannot be reproduced, except in full, without prior written permission of the Company.

Radiated Spurious Emission Measurement Result (above 1GHz)

Operation Mode	TX CH Mid	Test Date	Mar. 07, 2005
Fundamental Frequency	2441 MHz	Test By	Sky
Temperature	23	Pol	Hor
Humidity	54 %		

Freq. (MHz)	Peak	AV	Ant./CL CF(dB)	Actual FS		Peak	AV	Margin (dB)
	Reading (dBuV)	Reading (dBuV)		Peak (dBuV/m)	AV (dBuV/m)	Limit (dBuV/m)	Limit (dBuV/m)	
1598.0	44.70	--	-6.81	37.89	--	74.00	54.00	-16.11
4882.0	39.07	--	3.18	42.25	--	74.00	54.00	-11.75
7324.5	42.09	--	9.47	51.56	--	74.00	54.00	-2.44
9764.0	----							
12205.0	----							
14646.0	----							
17087.0	----							
19528.0	----							
21969.0	----							
24410.0	----							

Remark :

- (1) Measuring frequencies scanned from 1GHz to the 10th harmonic of highest fundamental frequency.
- (2) Datas of measurement within this frequency range shown “ - ” in the table above means the reading of emissions are attenuated more than 20dB below the permissible limits or the field strength is too small to be measured.
- (3) Radiated emissions measured in frequency above 1000MHz were made with an instrument using Peak detector mode and average detector mode of the emission shown in Actual FS column.
- (4) Spectrum Peak Setting : 1GHz- 26GHz, RBW= 1MHz, VBW= 3MHz, Sweep time= 200 ms.
- (5) Spectrum AV Setting : 1GHz- 26GHz, RBW= 1MHz, VBW= 10Hz, Sweep time= 200 ms.

The results shown in this test report refer only to the sample(s) tested unless otherwise stated. This test report cannot be reproduced, except in full, without prior written permission of the Company.

Radiated Spurious Emission Measurement Result (above 1GHz)

Operation Mode	TX CH High	Test Date	Mar. 07, 2005
Fundamental Frequency	2480 MHz	Test By	Sky
Temperature	23	Pol	Ver
Humidity	54 %		

Freq. (MHz)	Peak	AV	Ant./CL CF(dB)	Actual FS		Peak	AV	Margin (dB)
	Reading (dBuV)	Reading (dBuV)		Peak (dBuV/m)	AV (dBuV/m)	Limit (dBuV/m)	Limit (dBuV/m)	
1500.5	39.81	--	-7.17	32.64	--	74.00	54.00	-21.36
1598.0	42.93	--	-6.81	36.12	--	74.00	54.00	-17.88
2480.0								
7440.0	----							
9920.0	----							
12400.0	----							
14880.0	----							
17360.0	----							
19840.0	----							
22320.0	----							
24800.0	----							

Remark :

- (1) Measuring frequencies scanned from 1GHz to the 10th harmonic of highest fundamental frequency.
- (2) Datas of measurement within this frequency range shown “ - ” in the table above means the reading of emissions are attenuated more than 20dB below the permissible limits or the field strength is too small to be measured.
- (3) Radiated emissions measured in frequency above 1000MHz were made with an instrument using Peak detector mode and average detector mode of the emission shown in Actual FS column.
- (4) Spectrum Peak Setting : 1GHz- 26GHz, RBW= 1MHz, VBW= 3MHz, Sweep time= 200 ms.
- (5) Spectrum AV Setting : 1GHz- 26GHz, RBW= 1MHz, VBW= 10Hz, Sweep time= 200 ms.

The results shown in this test report refer only to the sample(s) tested unless otherwise stated. This test report cannot be reproduced, except in full, without prior written permission of the Company.

Radiated Spurious Emission Measurement Result (above 1GHz)

Operation Mode	TX CH High	Test Date	Mar. 07, 2005
Fundamental Frequency	2480 MHz	Test By	Sky
Temperature	23	Pol	Hor
Humidity	54 %		

Freq. (MHz)	Peak	AV	Ant./CL CF(dB)	Actual FS		Peak	AV	Margin (dB)
	Reading (dBuV)	Reading (dBuV)		Peak (dBuV/m)	AV (dBuV/m)	Limit (dBuV/m)	Limit (dBuV/m)	
1500.5	44.81	--	-7.17	37.64	--	74.00	54.00	-16.36
1598.0	44.62	--	-6.81	37.81	--	74.00	54.00	-16.19
2605.5	41.77	--	-2.76	39.01	--	74.00	54.00	-14.99
4960.0	----							
7440.0	----							
9920.0	----							
12400.0	----							
14880.0	----							
17360.0	----							
19840.0	----							
22320.0	----							
24800.0	----							

Remark :

- (1) Measuring frequencies scanned from 1GHz to the 10th harmonic of highest fundamental frequency.
- (2) Datas of measurement within this frequency range shown “ - ” in the table above means the reading of emissions are attenuated more than 20dB below the permissible limits or the field strength is too small to be measured.
- (3) Radiated emissions measured in frequency above 1000MHz were made with an instrument using Peak detector mode and average detector mode of the emission shown in Actual FS column.
- (4) Spectrum Peak Setting : 1GHz- 26GHz, RBW= 1MHz, VBW= 3MHz, Sweep time= 200 ms.
- (5) Spectrum AV Setting : 1GHz- 26GHz, RBW= 1MHz, VBW= 10Hz, Sweep time= 200 ms.

The results shown in this test report refer only to the sample(s) tested unless otherwise stated. This test report cannot be reproduced, except in full, without prior written permission of the Company.

Radiated Spurious Emission Measurement Result (below 1GHz)

Operation Mode	RX CH Low	Test Date	Mar. 07, 2005
Fundamental Frequency	2402MHz	Test By	Sky
Temperature	23	Pol	Ver./Hor
Humidity	54 %		

Freq. (MHz)	Ant.Pol. H/V	Detector Mode (PK/QP)	Reading (dBuV)	Factor (dB)	Actual FS (dBuV/m)	Limit3m (dBuV/m)	Safe Margin (dB)
65.89	V	Peak	50.02	-15.67	34.35	40.00	-5.65
300.63	V	Peak	47.38	-13.37	34.01	46.00	-11.99
499.48	V	Peak	43.70	-9.30	34.40	46.00	-11.60
533.43	V	Peak	38.62	-8.75	29.87	46.00	-16.13
749.74	V	Peak	34.29	-4.46	29.83	46.00	-16.17
866.14	V	Peak	34.69	-2.61	32.08	46.00	-13.92
98.87	H	Peak	50.78	-17.31	33.47	43.50	-10.03
300.63	H	Peak	46.51	-13.37	33.14	46.00	-12.86
465.53	H	Peak	44.41	-6.63	37.78	46.00	-8.22
500.45	H	Peak	43.49	-9.28	34.21	46.00	-11.79
599.39	H	Peak	42.55	-7.64	34.91	46.00	-11.09
866.14	H	Peak	37.81	-2.61	35.20	46.00	-10.80

Remark :

- (1) Measuring frequencies from 30 MHz to the 1GHz.
- (2) Radiated emissions measured in frequency range from 30 MHz to 1000MHz were made with an instrument using Peak/QP detector mode.
- (3) Datas of measurement within this frequency range shown “ - ” in the table above means the reading of emissions are attenuated more than 20dB below the permissible limits or the field strength is too small to be measured.
- (4) The IF bandwidth of SPA between 30MHz to 1GHz was 100KHz.

The results shown in this test report refer only to the sample(s) tested unless otherwise stated. This test report cannot be reproduced, except in full, without prior written permission of the Company.

Radiated Spurious Emission Measurement Result (below 1GHz)

Operation Mode	RX CH Mid	Test Date	Mar. 07, 2005
Fundamental Frequency	2441MHz	Test By	Sky
Temperature	23	Pol	Ver./Hor
Humidity	54 %		

Freq. (MHz)	Ant.Pol. H/V	Detector Mode (PK/QP)	Reading (dBuV)	Factor (dB)	Actual FS (dBuV/m)	Limit3m (dBuV/m)	Safe Margin (dB)
67.83	V	Peak	49.51	-15.88	33.63	40.00	-6.37
300.63	V	Peak	45.59	-13.37	32.22	46.00	-13.78
465.53	V	Peak	39.03	-6.63	32.40	46.00	-13.60
499.48	V	Peak	42.30	-9.30	33.00	46.00	-13.00
567.38	V	Peak	38.75	-8.18	30.57	46.00	-15.43
866.14	V	Peak	34.65	-2.61	32.04	46.00	-13.96
99.84	H	Peak	52.74	-17.23	35.51	43.50	-7.99
300.63	H	Peak	47.24	-13.37	33.87	46.00	-12.13
465.53	H	Peak	44.09	-9.63	34.46	46.00	-11.54
500.45	H	Peak	43.58	-9.28	34.30	46.00	-11.70
567.38	H	Peak	42.73	-8.18	34.55	46.00	-11.45
866.14	H	Peak	37.37	-2.61	34.76	46.00	-11.24

Remark :

- (1) Measuring frequencies from 30 MHz to the 1GHz.
- (2) Radiated emissions measured in frequency range from 30 MHz to 1000MHz were made with an instrument using Peak/QP detector mode.
- (3) Datas of measurement within this frequency range shown “ - ” in the table above means the reading of emissions are attenuated more than 20dB below the permissible limits or the field strength is too small to be measured.
- (4) The IF bandwidth of SPA between 30MHz to 1GHz was 100KHz.

The results shown in this test report refer only to the sample(s) tested unless otherwise stated. This test report cannot be reproduced, except in full, without prior written permission of the Company.

Radiated Spurious Emission Measurement Result (below 1GHz)

Operation Mode	RX CH High	Test Date	Mar. 07, 2005
Fundamental Frequency	2480MHz	Test By	Sky
Temperature	23	Pol	Ver./Hor
Humidity	54 %		

Freq. (MHz)	Ant.Pol. H/V	Detector Mode (PK/QP)	Reading (dBuV)	Factor (dB)	Actual FS (dBuV/m)	Limit3m (dBuV/m)	Safe Margin (dB)
92.08	V	Peak	47.92	-17.77	30.15	43.50	-13.35
300.63	V	Peak	45.17	-13.37	31.80	46.00	-14.20
499.48	V	Peak	41.87	-9.30	32.57	46.00	-13.43
567.38	V	Peak	37.58	-8.18	29.40	46.00	-16.60
749.74	V	Peak	34.18	-4.46	29.72	46.00	-16.28
866.14	V	Peak	34.56	-2.61	31.95	46.00	-14.05
98.87	H	Peak	52.25	-17.31	34.94	43.50	-8.56
301.60	H	Peak	46.90	-13.35	33.55	46.00	-12.45
500.45	H	Peak	43.76	-9.28	34.48	46.00	-11.52
567.38	H	Peak	42.03	-8.18	33.85	46.00	-12.15
749.74	H	Peak	39.00	-4.46	34.54	46.00	-11.46
866.14	H	Peak	36.68	-2.61	34.07	46.00	-11.93

Remark :

- (1) Measuring frequencies from 30 MHz to the 1GHz.
- (2) Radiated emissions measured in frequency range from 30 MHz to 1000MHz were made with an instrument using Peak/QP detector mode.
- (3) Datas of measurement within this frequency range shown “ - ” in the table above means the reading of emissions are attenuated more than 20dB below the permissible limits or the field strength is too small to be measured.
- (4) The IF bandwidth of SPA between 30MHz to 1GHz was 100KHz.

The results shown in this test report refer only to the sample(s) tested unless otherwise stated. This test report cannot be reproduced, except in full, without prior written permission of the Company.

Radiated Spurious Emission Measurement Result (above 1GHz)

Operation Mode	RX CH Low	Test Date	Mar. 07, 2005
Fundamental Frequency	2402 MHz	Test By	Henk
Temperature	23	Pol	Ver.
Humidity	54 %		

Freq. (MHz)	Peak	AV	Ant./CL CF(dB)	Actual FS		Peak	AV	Margin (dB)
	Reading (dBuV)	Reading (dBuV)		Peak (dBuV/m)	AV (dBuV/m)	Limit (dBuV/m)	Limit (dBuV/m)	
1500.5	39.90	---	-7.17	32.73	---	74.00	54.00	-21.27
1598.0	43.05	---	-6.81	36.24	---	74.00	54.00	-17.76
2391.0	45.85	---	3.40	49.25	---	74.00	54.00	-4.75
4804.0	----							
7206.0	----							
9608.0	----							
12010.0	----							
14412.0	----							
16814.0	----							
19216.0	----							
21618.0	----							
24020.0	----							

Remark :

- (1) Measuring frequencies from 1GHz to the 10th harmonic of highest fundamental frequency.
- (2) Datas of measurement within this frequency range shown “ - ” in the table above means the reading of emissions are attenuated more than 20dB below the permissible limits or the field strength is too small to be measured.
- (3) Radiated emissions measured in frequency above 1000MHz were made with an instrument using Peak detector mode and average detector mode of the emission shown in Actual FS column.
- (4) Spectrum Peak Setting : 1GHz- 26GHz, RBW= 3MHz, VBW= 1MHz, Sweep time= 200 ms.
- (5) Spectrum AV Setting : 1GHz- 26GHz, RBW= 1MHz, VBW= 10Hz, Sweep time= 200 ms.

The results shown in this test report refer only to the sample(s) tested unless otherwise stated. This test report cannot be reproduced, except in full, without prior written permission of the Company.

Radiated Spurious Emission Measurement Result (above 1GHz)

Operation Mode	RX CH Low	Test Date	Mar. 07, 2005
Fundamental Frequency	2402 MHz	Test By	Sky
Temperature	23	Pol	Hor
Humidity	54 %		

Freq. (MHz)	Peak	AV	Ant./CL CF(dB)	Actual FS		Peak	AV	Margin (dB)
	Reading (dBuV)	Reading (dBuV)		Peak (dBuV/m)	AV (dBuV/m)	Limit (dBuV/m)	Limit (dBuV/m)	
1500.5	41.89	---	-7.17	34.72	---	74.00	54.00	-19.28
598.0	44.11	---	-6.81	37.30	---	74.00	54.00	-16.70
2391.0	51.84	---	-3.40	48.44	---	74.00	54.00	-5.56
2605.5	41.27	---	-2.76	38.51	---	74.00	54.00	-15.49
4804.0	----							
7206.0	----							
9608.0	----							
12010.0	----							
14412.0	----							
16814.0	----							
19216.0	----							
21618.0	----							
24020.0	----							

Remark :

- (1) Measuring frequencies from 1GHz to the 10th harmonic of highest fundamental frequency.
- (2) Datas of measurement within this frequency range shown “ - ” in the table above means the reading of emissions are attenuated more than 20dB below the permissible limits or the field strength is too small to be measured.
- (3) Radiated emissions measured in frequency above 1000MHz were made with an instrument using Peak detector mode and average detector mode of the emission shown in Actual FS column.
- (4) Spectrum Peak Setting : 1GHz- 26GHz, RBW= 3MHz, VBW= 1MHz, Sweep time= 200 ms.
- (5) Spectrum AV Setting : 1GHz- 26GHz, RBW= 1MHz, VBW= 10Hz, Sweep time= 200 ms.

The results shown in this test report refer only to the sample(s) tested unless otherwise stated. This test report cannot be reproduced, except in full, without prior written permission of the Company.

Radiated Spurious Emission Measurement Result (above 1GHz)

Operation Mode	RX CH Mid	Test Date	Mar. 07, 2005
Fundamental Frequency	2441 MHz	Test By	Sky
Temperature	23	Pol	Ver
Humidity	54 %		

Freq. (MHz)	Peak	AV	Ant./CL CF(dB)	Actual FS		Peak	AV	Margin (dB)
	Reading (dBuV)	Reading (dBuV)		Peak (dBuV/m)	AV (dBuV/m)	Limit (dBuV/m)	Limit (dBuV/m)	
1598.0	40.57	---	-6.81	33.76	---	74.00	54.00	-20.24
2443.0	46.74	---	-3.18	43.56	---	74.00	54.00	-10.44
3450.5	36.75	---	1.18	37.93	---	74.00	54.00	-16.07
4882.0	----							
7323.0	----							
9764.0	----							
12205.0	----							
14646.0	----							
17087.0	----							
19528.0	----							
21969.0	----							
24410.0	----							

Remark :

- (1) Measuring frequencies from 1GHz to the 10th harmonic of highest fundamental frequency.
- (2) Datas of measurement within this frequency range shown “ - ” in the table above means the reading of emissions are attenuated more than 20dB below the permissible limits or the field strength is too small to be measured.
- (3) Radiated emissions measured in frequency above 1000MHz were made with an instrument using Peak detector mode and average detector mode of the emission shown in Actual FS column.
- (4) Spectrum Peak Setting : 1GHz- 26GHz, RBW= 3MHz, VBW= 1MHz, Sweep time= 200 ms.
- (5) Spectrum AV Setting : 1GHz- 26GHz, RBW= 1MHz, VBW= 10Hz, Sweep time= 200 ms.

The results shown in this test report refer only to the sample(s) tested unless otherwise stated. This test report cannot be reproduced, except in full, without prior written permission of the Company.

Radiated Spurious Emission Measurement Result (above 1GHz)

Operation Mode	RX CH Mid	Test Date	Mar. 07, 2005
Fundamental Frequency	2441 MHz	Test By	Sky
Temperature	23	Pol	Hor
Humidity	54 %		

Freq. (MHz)	Peak	AV	Ant./CL CF(dB)	Actual FS		Peak	AV	Margin (dB)
	Reading (dBuV)	Reading (dBuV)		Peak (dBuV/m)	AV (dBuV/m)	Limit (dBuV/m)	Limit (dBuV/m)	
1078.0	44.96	---	-9.12	35.84	---	74.00	54.00	-18.16
1598.0	44.84	---	-6.81	38.03	---	74.00	54.00	-15.97
2443.0	50.76	---	-3.18	47.58	---	74.00	54.00	-6.42
4882.0	----							
7323.0	----							
9764.0	----							
12205.0	----							
14646.0	----							
17087.0	----							
19528.0	----							
21969.0	----							
24410.0	----							

Remark :

- (1) Measuring frequencies from 1GHz to the 10th harmonic of highest fundamental frequency.
- (2) Datas of measurement within this frequency range shown “ - ” in the table above means the reading of emissions are attenuated more than 20dB below the permissible limits or the field strength is too small to be measured.
- (3) Radiated emissions measured in frequency above 1000MHz were made with an instrument using Peak detector mode and average detector mode of the emission shown in Actual FS column.
- (4) Spectrum Peak Setting : 1GHz- 26GHz, RBW= 3MHz, VBW= 1MHz, Sweep time= 200 ms.
- (5) Spectrum AV Setting : 1GHz- 26GHz, RBW= 1MHz, VBW= 10Hz, Sweep time= 200 ms.

The results shown in this test report refer only to the sample(s) tested unless otherwise stated. This test report cannot be reproduced, except in full, without prior written permission of the Company.

Radiated Spurious Emission Measurement Result (above 1GHz)

Operation Mode	RX CH High	Test Date	Mar. 07, 2005
Fundamental Frequency	2480 MHz	Test By	Sky
Temperature	23	Pol	Ver
Humidity	54 %		

Freq. (MHz)	Peak	AV	Ant./CL CF(dB)	Actual FS		Peak	AV	Margin (dB)
	Reading (dBuV)	Reading (dBuV)		Peak (dBuV/m)	AV (dBuV/m)	Limit (dBuV/m)	Limit (dBuV/m)	
1598.0	42.81	---	-6.81	36.00	---	74.00	54.00	-18.00
2475.5	47.86	---	-3.04	44.82	---	74.00	54.00	-9.18
3255.0	37.43	---	-1.54	35.89	---	74.00	54.00	-18.11
4960.0	---	---	---	---	---	---	---	---
7440.0	---	---	---	---	---	---	---	---
9920.0	---	---	---	---	---	---	---	---
12400.0	---	---	---	---	---	---	---	---
14880.0	---	---	---	---	---	---	---	---
17360.0	---	---	---	---	---	---	---	---
19840.0	---	---	---	---	---	---	---	---
22320.0	---	---	---	---	---	---	---	---
24800.0	---	---	---	---	---	---	---	---

Remark :

- (1) Measuring frequencies from 1GHz to the 10th harmonic of highest fundamental frequency.
- (2) Datas of measurement within this frequency range shown “ - ” in the table above means the reading of emissions are attenuated more than 20dB below the permissible limits or the field strength is too small to be measured.
- (3) Radiated emissions measured in frequency above 1000MHz were made with an instrument using Peak detector mode and average detector mode of the emission shown in Actual FS column.
- (4) Spectrum Peak Setting : 1GHz- 26GHz, RBW= 3MHz, VBW= 1MHz, Sweep time= 200 ms.
- (5) Spectrum AV Setting : 1GHz- 26GHz, RBW= 1MHz, VBW= 10Hz, Sweep time= 200 ms.

The results shown in this test report refer only to the sample(s) tested unless otherwise stated. This test report cannot be reproduced, except in full, without prior written permission of the Company.

Radiated Spurious Emission Measurement Result (above 1GHz)

Operation Mode	RX CH High	Test Date	Mar. 07, 2005
Fundamental Frequency	2480 MHz	Test By	Sky
Temperature	23	Pol	Hor
Humidity	54 %		

Freq. (MHz)	Peak	AV	Ant./CL CF(dB)	Actual FS		Peak	AV	Margin (dB)
	Reading (dBuV)	Reading (dBuV)		Peak (dBuV/m)	AV (dBuV/m)	Limit (dBuV/m)	Limit (dBuV/m)	
1500.5	42.39	---	-7.17	35.22	---	74.00	54.00	-18.78
1598.0	44.71	---	-6.81	37.90	---	74.00	54.00	-16.10
2475.5	50.94	---	-3.04	47.90	---	74.00	54.00	-6.10
4960.0	----							
7440.0	----							
9920.0	----							
12400.0	----							
14880.0	----							
17360.0	----							
19840.0	----							
22320.0	----							
24800.0	----							

Remark :

- (1) Measuring frequencies from 1GHz to the 10th harmonic of highest fundamental frequency.
- (2) Datas of measurement within this frequency range shown “ - ” in the table above means the reading of emissions are attenuated more than 20dB below the permissible limits or the field strength is too small to be measured.
- (3) Radiated emissions measured in frequency above 1000MHz were made with an instrument using Peak detector mode and average detector mode of the emission shown in Actual FS column.
- (4) Spectrum Peak Setting : 1GHz- 26GHz, RBW= 3MHz, VBW= 1MHz, Sweep time= 200 ms.
- (5) Spectrum AV Setting : 1GHz- 26GHz, RBW= 1MHz, VBW= 10Hz, Sweep time= 200 ms.

The results shown in this test report refer only to the sample(s) tested unless otherwise stated. This test report cannot be reproduced, except in full, without prior written permission of the Company.

10. FREQUENCY SEPARATION

10.1 Standard Applicable

According to §15.247(a)(1), Frequency hopping systems shall have hopping channel carrier frequencies separated by minimum of 25KHz or the 20dB bandwidth of the hopping channel, whichever is greater.

According to §6.2.2(o)(a1), FH systems shall have hopping channel carrier frequencies separated by a minimum of 25 kHz or the 20 dB bandwidth of the hopping channel, whichever is greater.

10.2 Measurement Procedure

1. Place the EUT on the table and set it in transmitting mode.
2. Remove the antenna from the EUT and then connect a low loss RF cable from the antenna port to the spectrum analyzer.
3. Set center frequency of spectrum analyzer = middle of hopping channel .
4. Set the spectrum analyzer as RBW,VBW=3KHz, Adjust Span to 3.0 MHz, Sweep = auto.
5. Max hold. Mark 3 Peaks of hopping channel and record the 3 peaks frequency.

10.3 Measurement Result

Channel separation	Limit	Result
MHz	kHz	
1	>=25	PASS

10.4 Measurement Equipment Used:

EQUIPMENT TYPE	MFR	MODEL NUMBER	SERIAL NUMBER	LAST CAL.	CAL DUE.
Spectrum Analyzer	R&S	FSP 40	100034	05/27/2004	05/26/2005
Spectrum Analyzer	Agilent	E7405A	US41160416	08/27/2004	08/27/2005
Low Loss Cable	HUBER+SUHNER	SUCOFLEX 104PEA	N/A	N/A	N/A
Attenuator	Mini-Circuit	BW-S6W5	N/A	10/07/2004	10/06/2005

The results shown in this test report refer only to the sample(s) tested unless otherwise stated. This test report cannot be reproduced, except in full, without prior written permission of the Company.

Frequency Separation Test Data

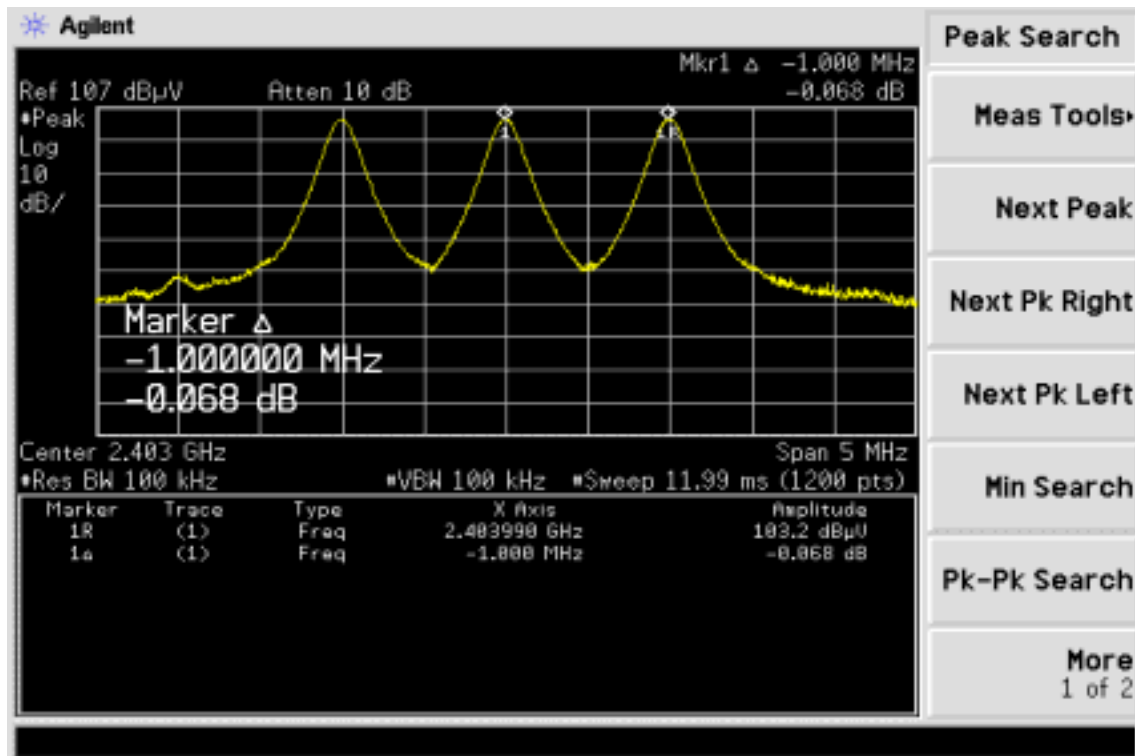

The results shown in this test report refer only to the sample(s) tested unless otherwise stated. This test report cannot be reproduced, except in full, without prior written permission of the Company.

11. NUMBER OF HOPPING FREQUENCY

11.1 Standard Applicable

According to §15.247(a)(1)(iii), Frequency hopping systems operating in the 2400MHz-2483.5 MHz bands shall use at least 15 hopping frequencies.

According to §6.2.2(o)(a3), Frequency hopping systems in the 2400-2483.5 MHz band may utilize hopping channels whose 20 dB bandwidth is greater than 1 MHz provided the systems use at least 15 non-overlapping.

11.2 Measurement Procedure

1. Place the EUT on the table and set it in transmitting mode.
2. Remove the antenna from the EUT and then connect a low loss RF cable from the antenna port to the spectrum analyzer.
3. Set spectrum analyzer Start=2400MHz, Stop = 2483.5MHz, Sweep = auto.
4. Set the spectrum analyzer as RBW, VBW=100KHz,
5. Max hold, view and count how many channel in the band.

11.3 Measurement Result

Total No of hopping channel	Limit (CH)	Measurement result (CH)	Result
	15	79	Pass

11.4 Measurement Equipment Used:

EQUIPMENT TYPE	MFR	MODEL NUMBER	SERIAL NUMBER	LAST CAL.	CAL DUE.
Spectrum Analyzer	R&S	FSP 40	100034	05/27/2004	05/26/2005
Spectrum Analyzer	Agilent	E7405A	US41160416	08/27/2004	08/27/2005
Low Loss Cable	HUBER+SUHNER	SUCOFLEX 104PEA	N/A	N/A	N/A
Attenuator	Mini-Circuit	BW-S6W5	N/A	10/07/2004	10/06/2005

The results shown in this test report refer only to the sample(s) tested unless otherwise stated. This test report cannot be reproduced, except in full, without prior written permission of the Company.

Channel Number

2.4 GHz – 2.441GHz

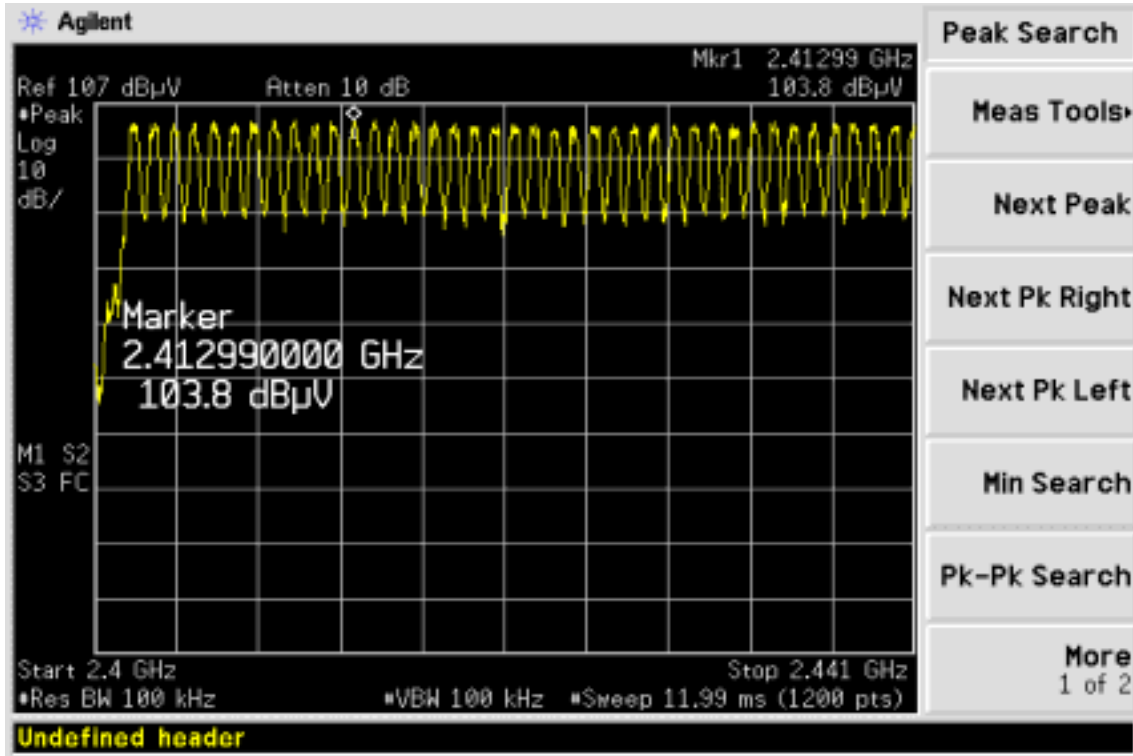

2.441 GHz – 2.4835GHz

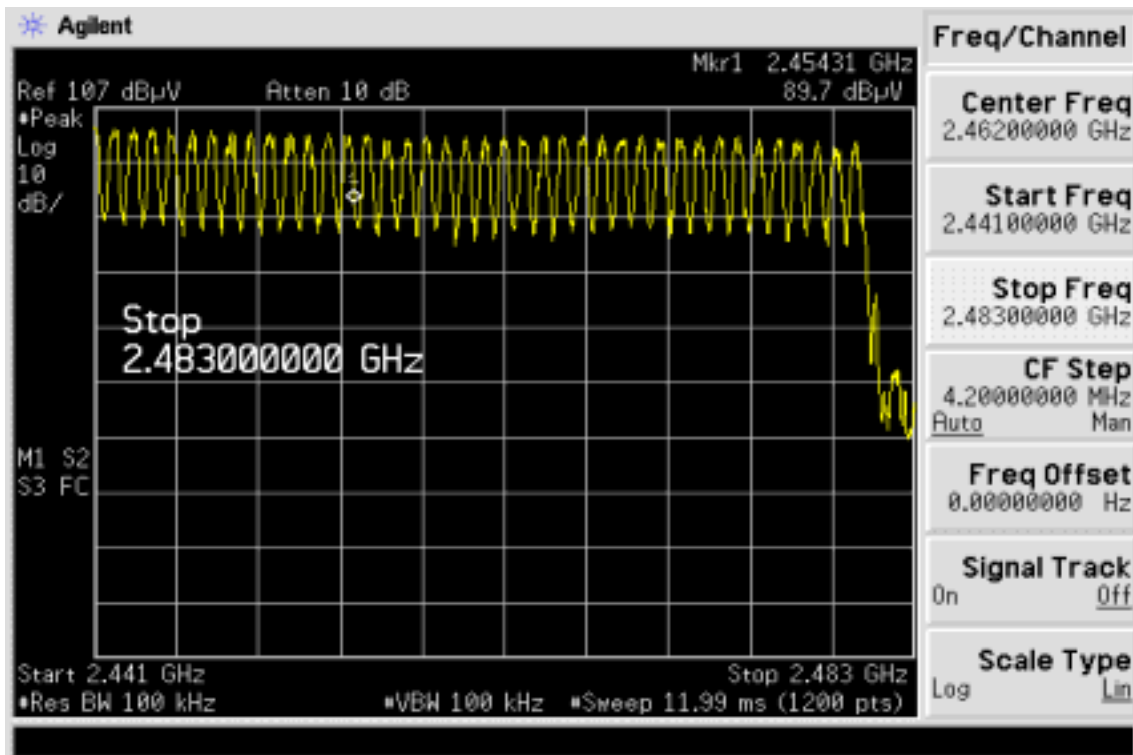

The results shown in this test report refer only to the sample(s) tested unless otherwise stated. This test report cannot be reproduced, except in full, without prior written permission of the Company.

12. TIME OF OCCUPANCY (DWELL TIME)

12.1. Standard Applicable

According to §15.247(a)(1)(iii), Frequency hopping systems operating in the 2400MHz-2483.5 MHz. The average time of occupancy on any frequency shall not greater than 0.4 s within period of 0.4 seconds multiplied by the number of hopping channel employed.

According to §6.2.2(o)(a3), The time of occupancy on any one channel shall be no greater than 0.4 seconds within the time period required to hop through all channels and each of the hopping channels must be used equally on the average.

12.2. Measurement Procedure

1. Place the EUT on the table and set it in transmitting mode.
2. Remove the antenna from the EUT and then connect a low loss RF cable from the antenna port to the spectrum analyzer.
3. Set center frequency of spectrum analyzer = operating frequency.
4. Set the spectrum analyzer as RBW,VBW=100KHz, Span = 0Hz , Adjust Sweep = 30s.
5. Repeat above procedures until all frequency measured were complete.

12.3. Measurement Result

A period time = 0.4 (ms) * 79 = 31.6 (s)

CH Low: DH1 time slot = 0.405 (ms) * (1600/(2*79)) * 31.6 = 129.6 (ms)
 DH3 time slot = 1.675 (ms) * (1600/(4*79)) * 31.6 = 268 (ms)
 DH5 time slot = 2.295 (ms) * (1600/(6*79)) * 31.6 = 312 (ms)

CH Mid: DH1 time slot = 0.405 (ms) * (1600/(2*79)) * 31.6 = 129.6 (ms)
 DH3 time slot = 1.675 (ms) * (1600/(4*79)) * 31.6 = 268 (ms)
 DH5 time slot = 2.906 (ms) * (1600/(6*79)) * 31.6 = 309.97 (ms)

CH High: DH1 time slot = 0.416 (ms) * (1600/(2*79)) * 31.6 = 129.6 (ms)
 DH3 time slot = 1.662 (ms) * (1600/(4*79)) * 31.6 = 265.92 (ms)
 DH5 time slot = 2.906 (ms) * (1600/(6*79)) * 31.6 = 309.97 (ms)

The results shown in this test report refer only to the sample(s) tested unless otherwise stated. This test report cannot be reproduced, except in full, without prior written permission of the Company.

12.4. Measurement Equipment Used:

EQUIPMENT TYPE	MFR	MODEL NUMBER	SERIAL NUMBER	LAST CAL.	CAL DUE.
Spectrum Analyzer	R&S	FSP 40	100034	05/27/2004	05/26/2005
Spectrum Analyzer	Agilent	E7405A	US41160416	08/27/2004	08/26/2005
Low Loss Cable	HUBER+SUHNER	SUCOFLEX 104PEA	N/A	N/A	N/A
Attenuator	Mini-Circuit	BW-S6W5	N/A	10/07/2004	10/06/2005

Dwell Time Test Data

CH-Low

DH1

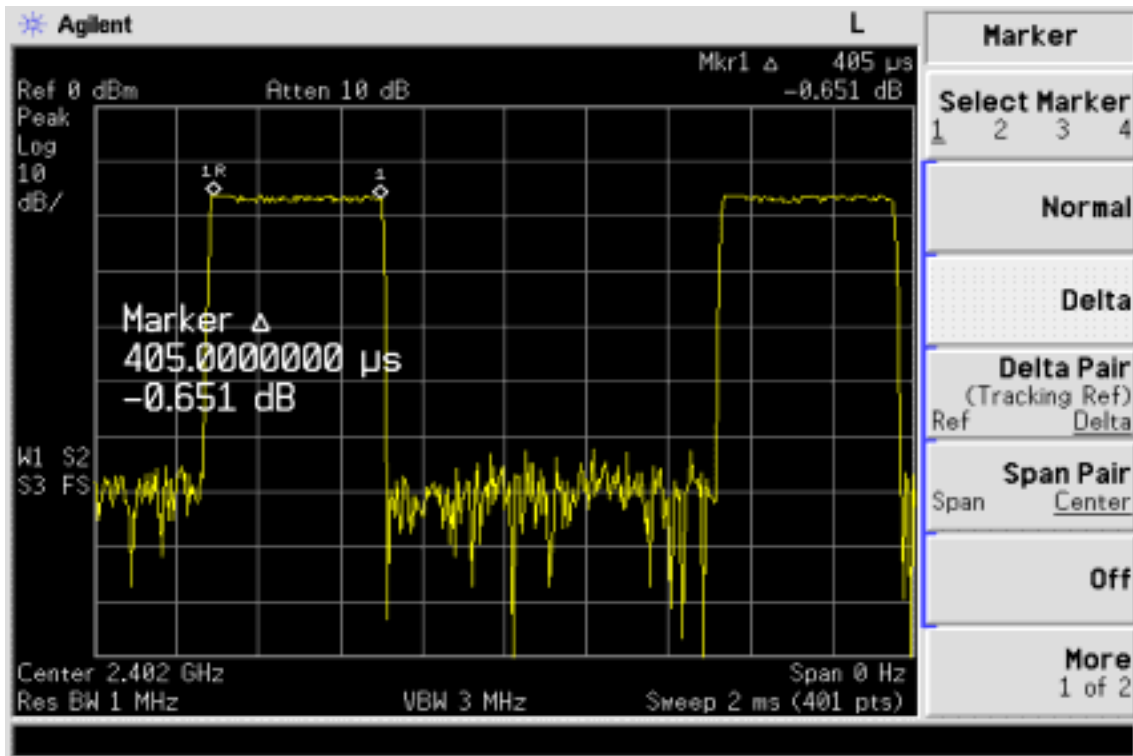

The results shown in this test report refer only to the sample(s) tested unless otherwise stated. This test report cannot be reproduced, except in full, without prior written permission of the Company.

DH3

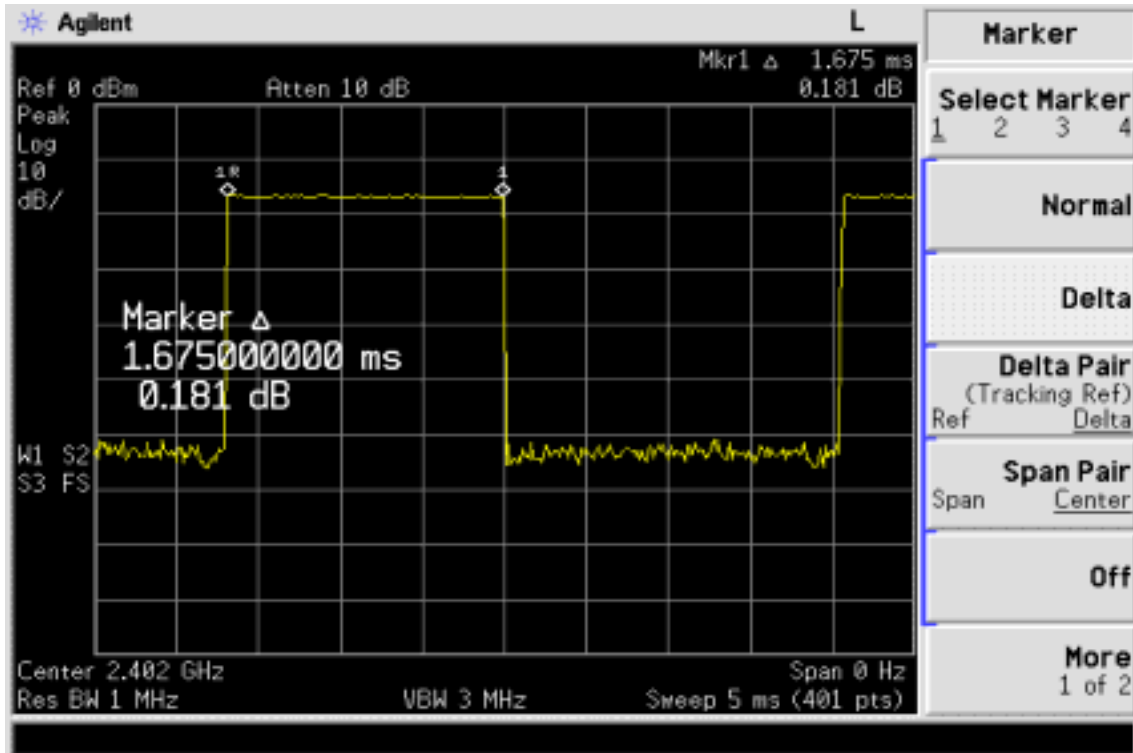

DH5

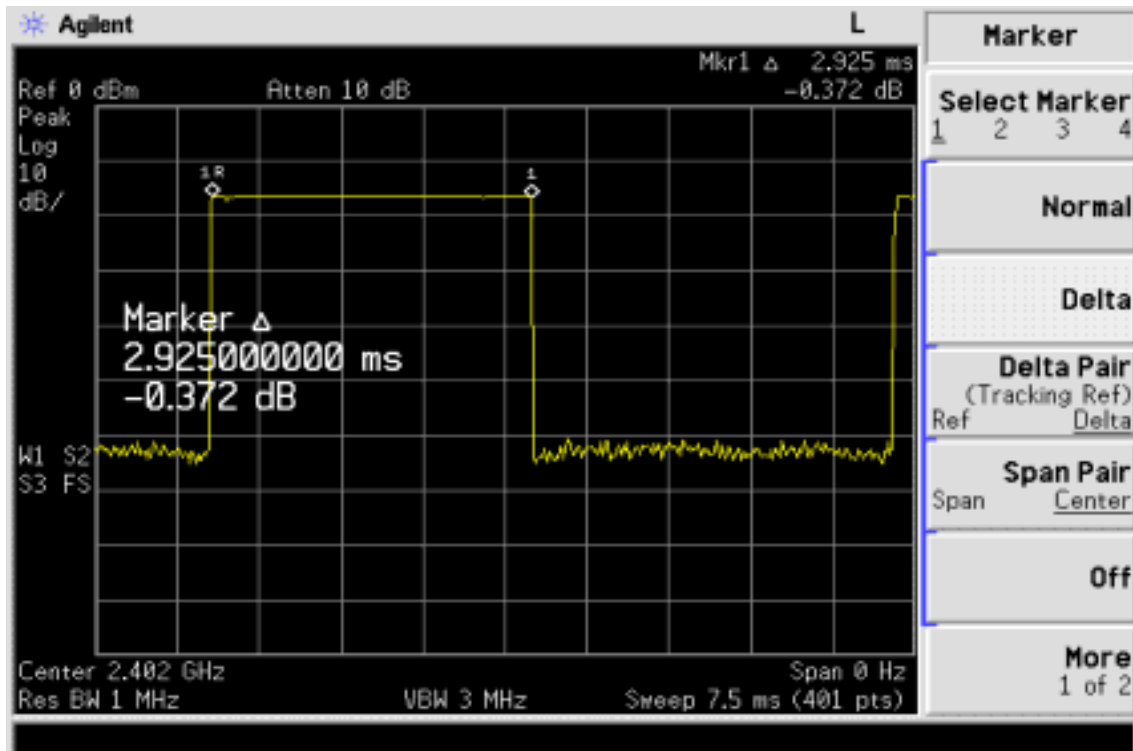

The results shown in this test report refer only to the sample(s) tested unless otherwise stated. This test report cannot be reproduced, except in full, without prior written permission of the Company.

CH-Mid
DH1

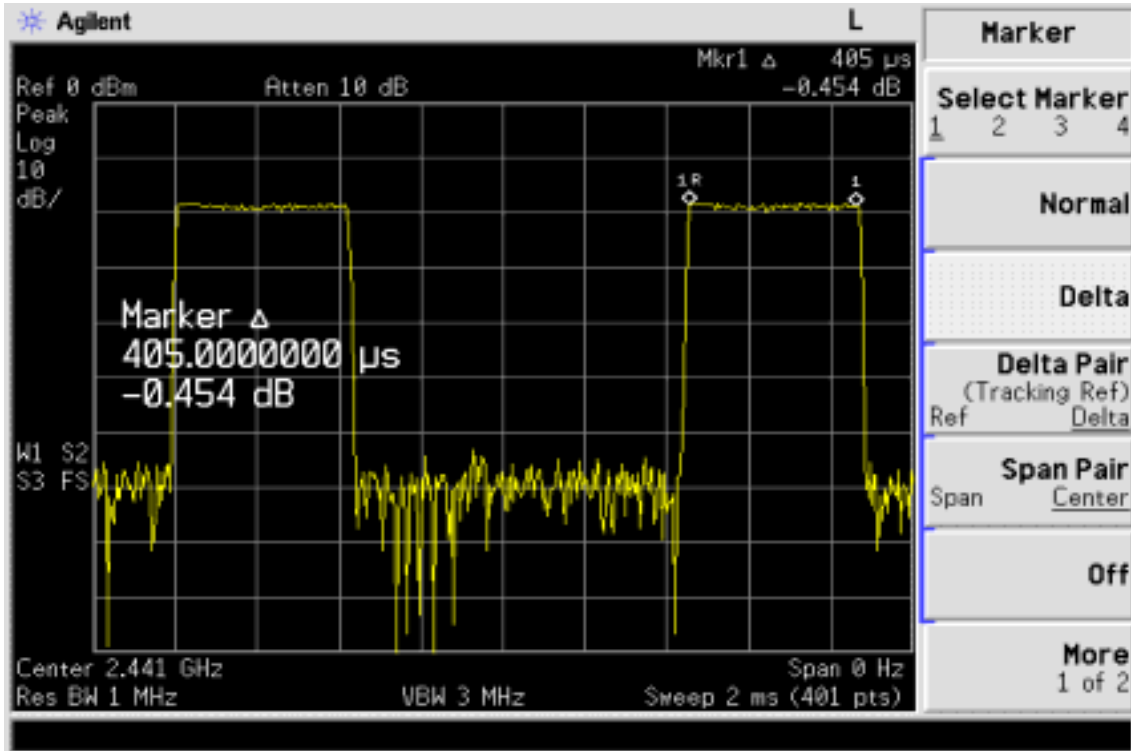

DH3

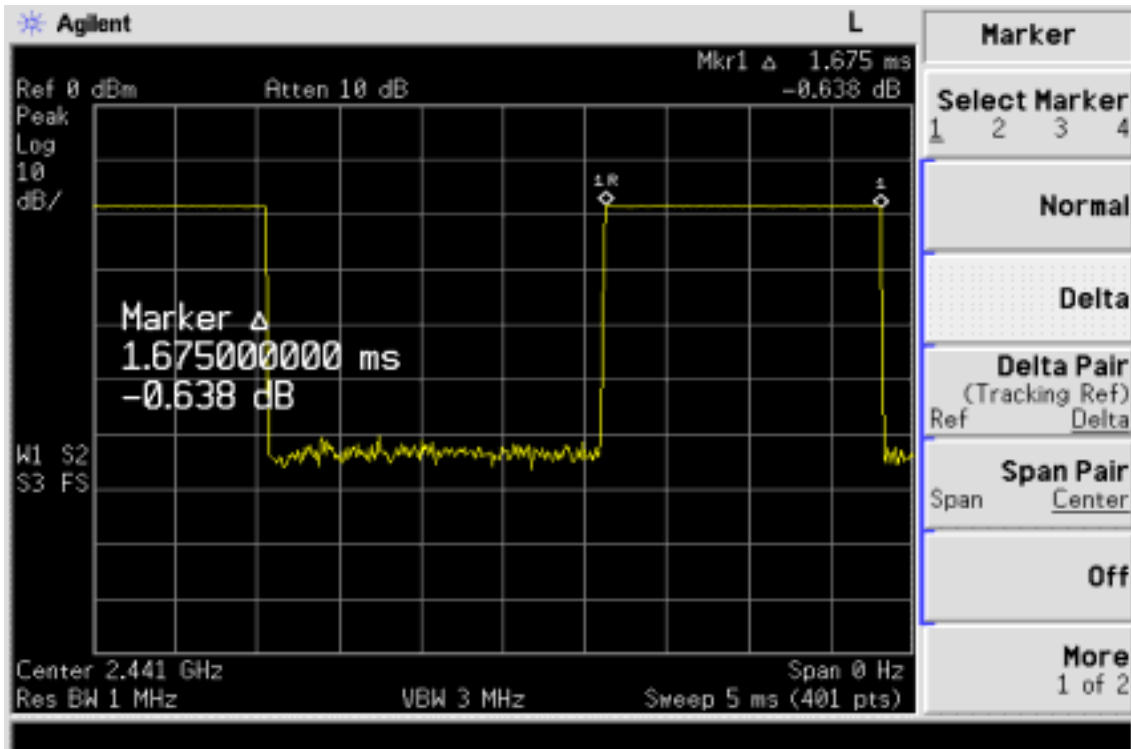

The results shown in this test report refer only to the sample(s) tested unless otherwise stated. This test report cannot be reproduced, except in full, without prior written permission of the Company.

DH5

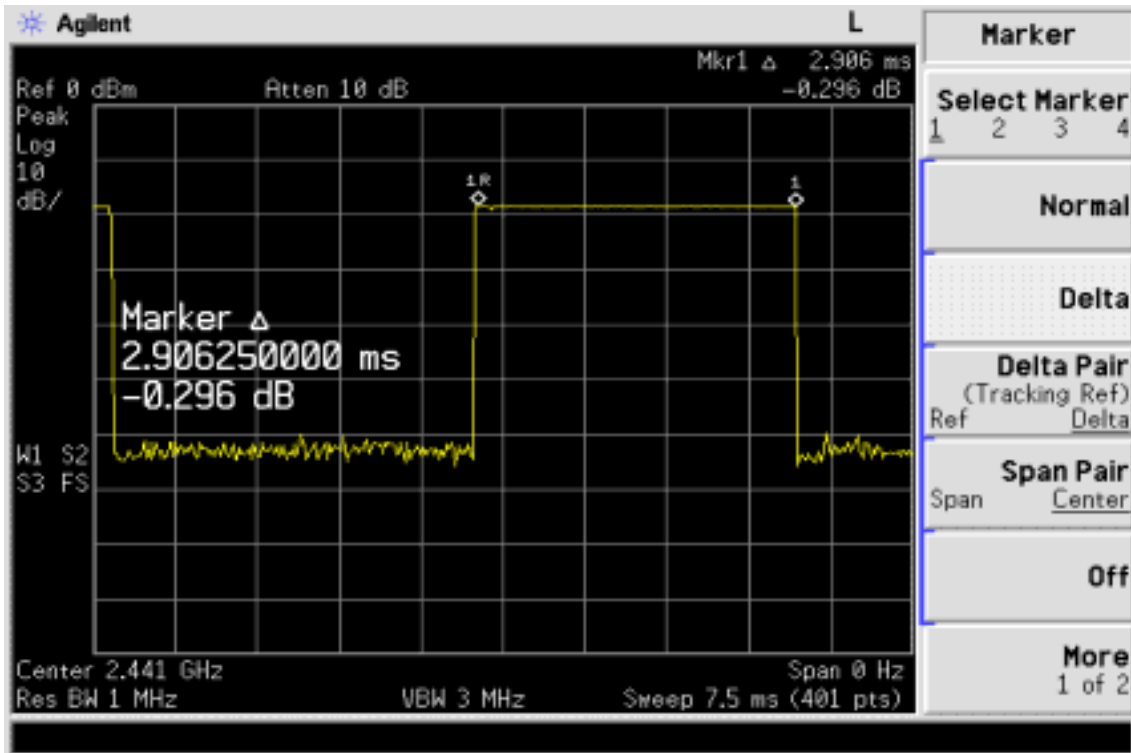

CH-High

DH1

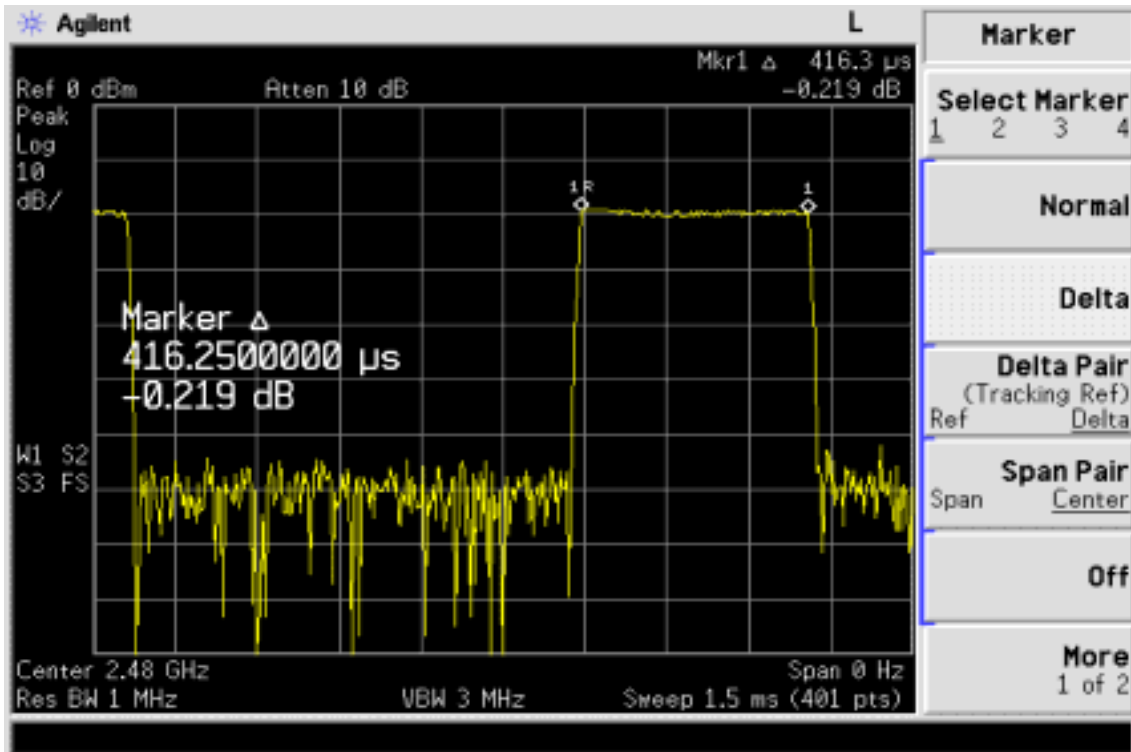

The results shown in this test report refer only to the sample(s) tested unless otherwise stated. This test report cannot be reproduced, except in full, without prior written permission of the Company.

DH3

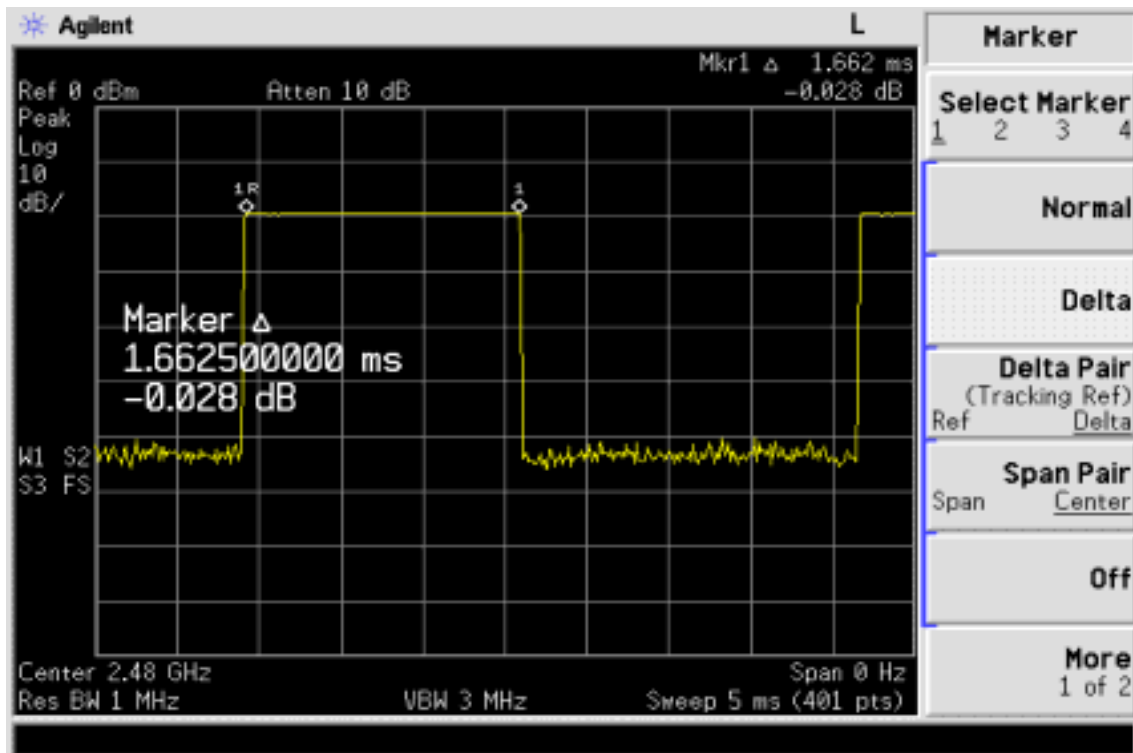

DH5

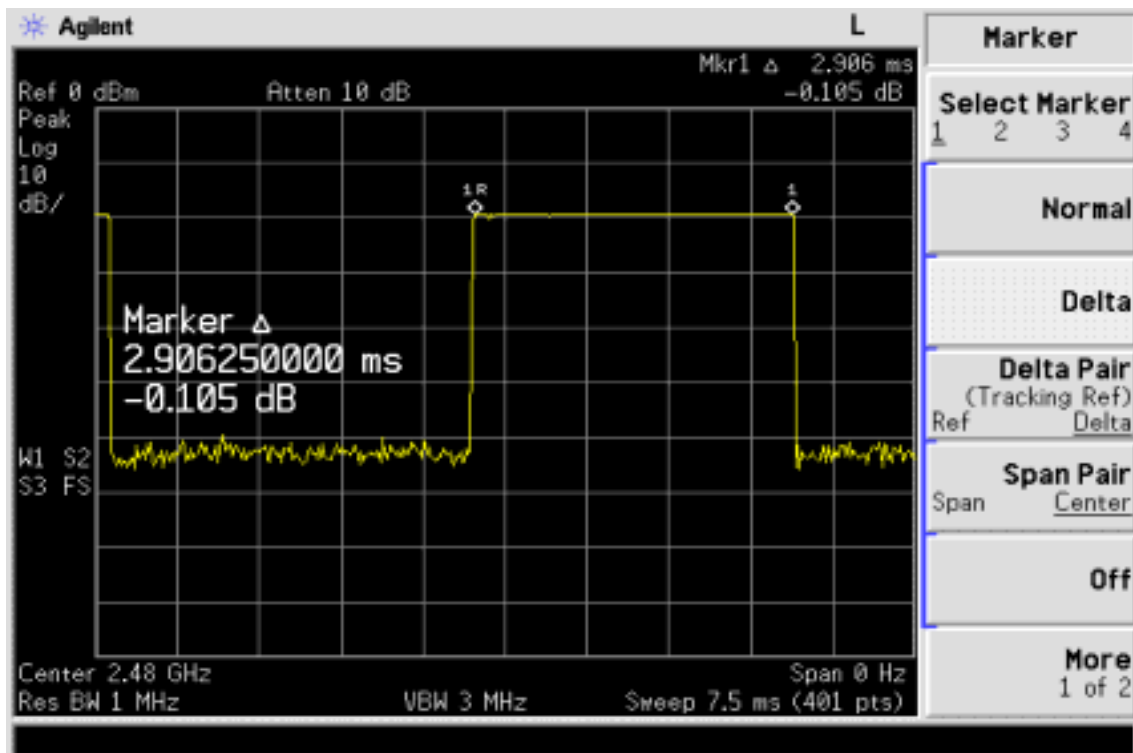

The results shown in this test report refer only to the sample(s) tested unless otherwise stated. This test report cannot be reproduced, except in full, without prior written permission of the Company.

13. Peak Power Spectral Density

13.1. Standard Applicable

According to §15.247(d), for direct sequence systems, the peak power spectral density conducted from the intentional radiator to the antenna shall not be greater than 8 dBm in any 3kHz band during any time interval of continuous transmission.

13.2. Measurement Procedure

1. Place the EUT on the table and set it in transmitting mode.
2. Remove the antenna from the EUT and then connect a low loss RF cable from the antenna port to the spectrum analyzer.
3. Set the spectrum analyzer as RBW = 3KHz, VBW = 3KHz, Span = 300KHz, Sweep=100s
4. Record the max. reading.
5. Repeat above procedures until all frequency measured were complete.

13.3. Measurement Result

CH	RF Power Density Reading (dBm)	Cable loss (dB)	RF Power Density Level (dBm)	Maximum Limit (dBm)
Low	-8.38	0.20	-8.18	8
Mid	-9.52	0.20	-9.32	8
High	-9.43	0.20	-9.23	8

13.4. Measurement Equipment Used:

EQUIPMENT TYPE	MFR	MODEL NUMBER	SERIAL NUMBER	LAST CAL.	CAL DUE.
Spectrum Analyzer	R&S	FSP 40	100034	05/27/2004	05/26/2005
Spectrum Analyzer	Agilent	E7405A	US41160416	08/27/2004	08/27/2005
Low Loss Cable	HUBER+SUHNER	SUCOFLEX 104PEA	N/A	N/A	N/A
Attenuator	Mini-Circuit	BW-S6W5	N/A	10/07/2004	10/06/2005

The results shown in this test report refer only to the sample(s) tested unless otherwise stated. This test report cannot be reproduced, except in full, without prior written permission of the Company.

Power Spectral Density Test Plot (CH-Low)

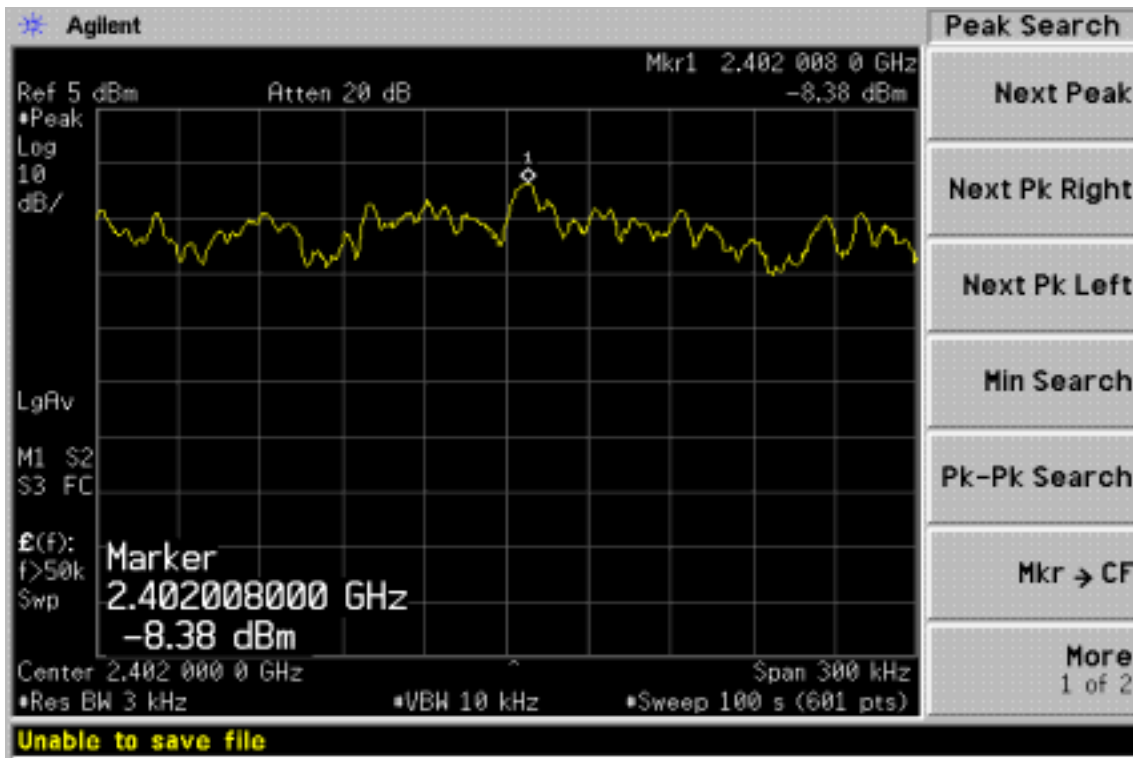

Power Spectral Density Test Plot (CH-Mid)

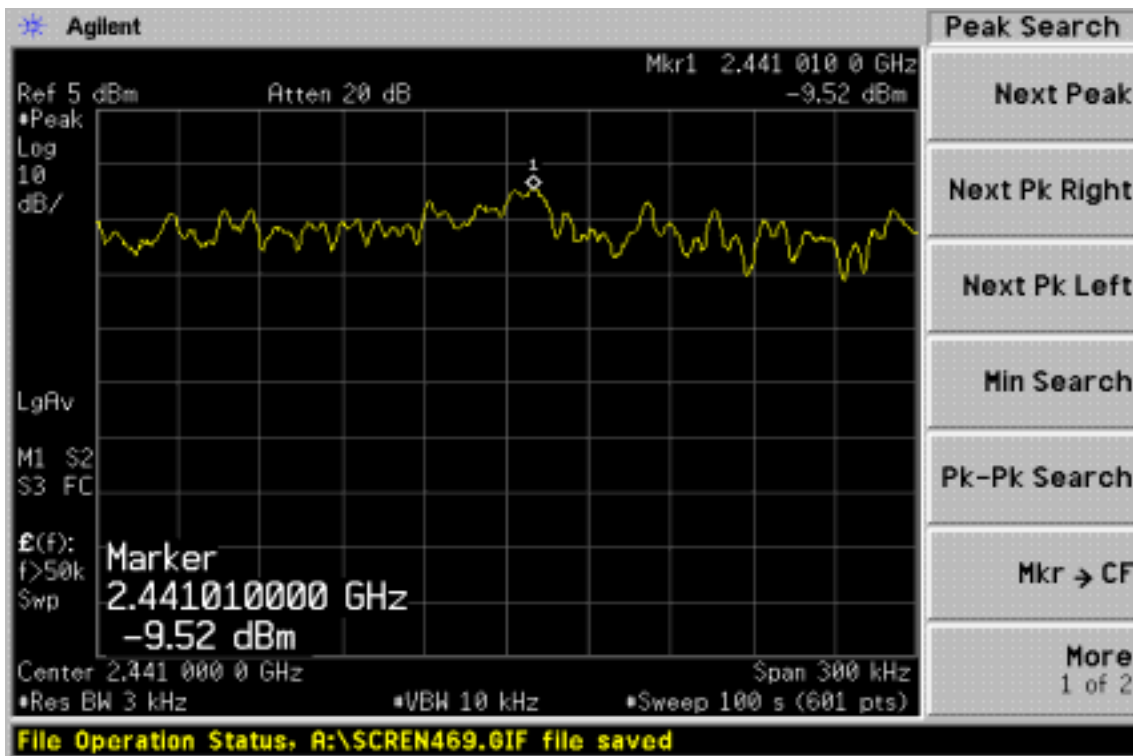

The results shown in this test report refer only to the sample(s) tested unless otherwise stated. This test report cannot be reproduced, except in full, without prior written permission of the Company.

Power Spectral Density Test Plot (CH-High)

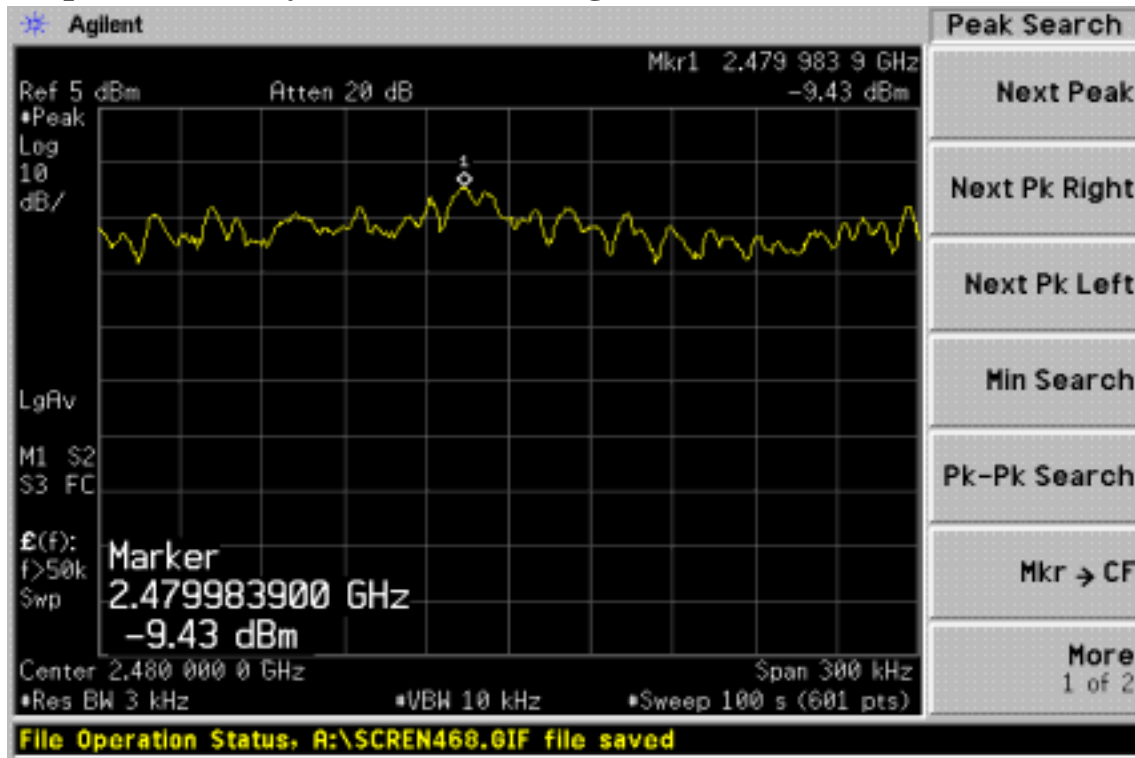

The results shown in this test report refer only to the sample(s) tested unless otherwise stated. This test report cannot be reproduced, except in full, without prior written permission of the Company.

14. 99% Bandwidth Measurement

14.1. Standard Applicable

RSS 210, section 5.9.1, An alternative to the 20 dB bandwidth is the 99% emission bandwidth. This bandwidth is determined such that below the lower and above the upper frequency limits, the mean powers emitted are each equal to 0.5% of the total mean power of the emission.

14.2. Measurement Equipment Used:

EQUIPMENT TYPE	MFR	Model No.	Serial No.	LAST CAL.	Cal. Due.
Spectrum Analyzer	R&S	FSP30	1093.4495.30	07/23/2004	07/22/2005
low loss cable	Huber + Suhner	Sucoflex 104	N/A	N/A	N/A

14.3. Test Set-up:

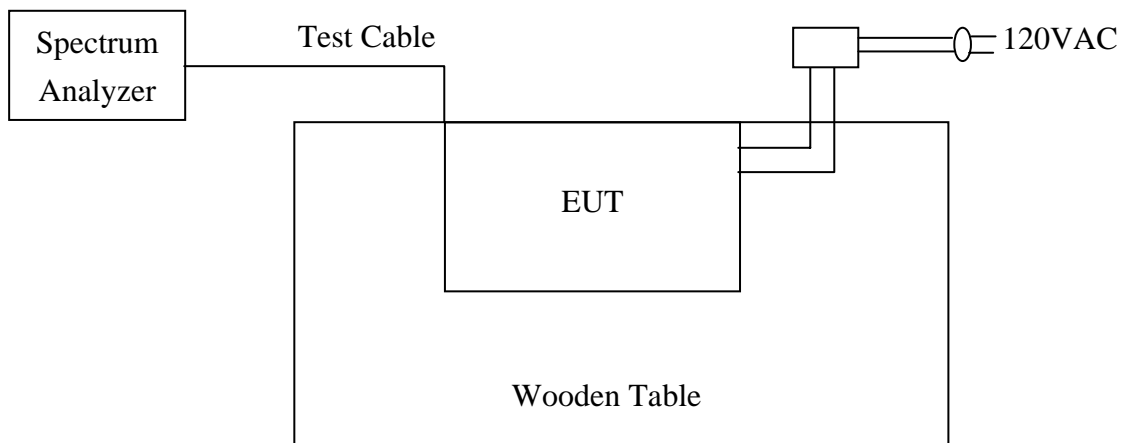

Fig. 4

Fig. 4 : Measurement setup for testing on Antenna connector

The results shown in this test report refer only to the sample(s) tested unless otherwise stated. This test report cannot be reproduced, except in full, without prior written permission of the Company.

14.4. Measurement Procedure

1. Place the EUT on the table and set it in transmitting mode.
2. Remove the antenna from the EUT and then connect a low loss RF cable from the antenna port to the spectrum analyzer.
3. Set the spectrum analyzer as RBW=1% of the approximate emission bandwidth, VBW = 3 times RBW, Span= approximately 20dB below the peak level. Sweep=auto
4. Turn on the 99% bandwidth function, max reading..
5. Repeat above procedures until all frequency measured were complete.

14.5. Measurement Result

CH	Bandwidth (KHz)
Lower	852.2998
Mid	899.7119
Higher	988.8433

The results shown in this test report refer only to the sample(s) tested unless otherwise stated. This test report cannot be reproduced, except in full, without prior written permission of the Company.

99% Band Width Test Data CH-Low

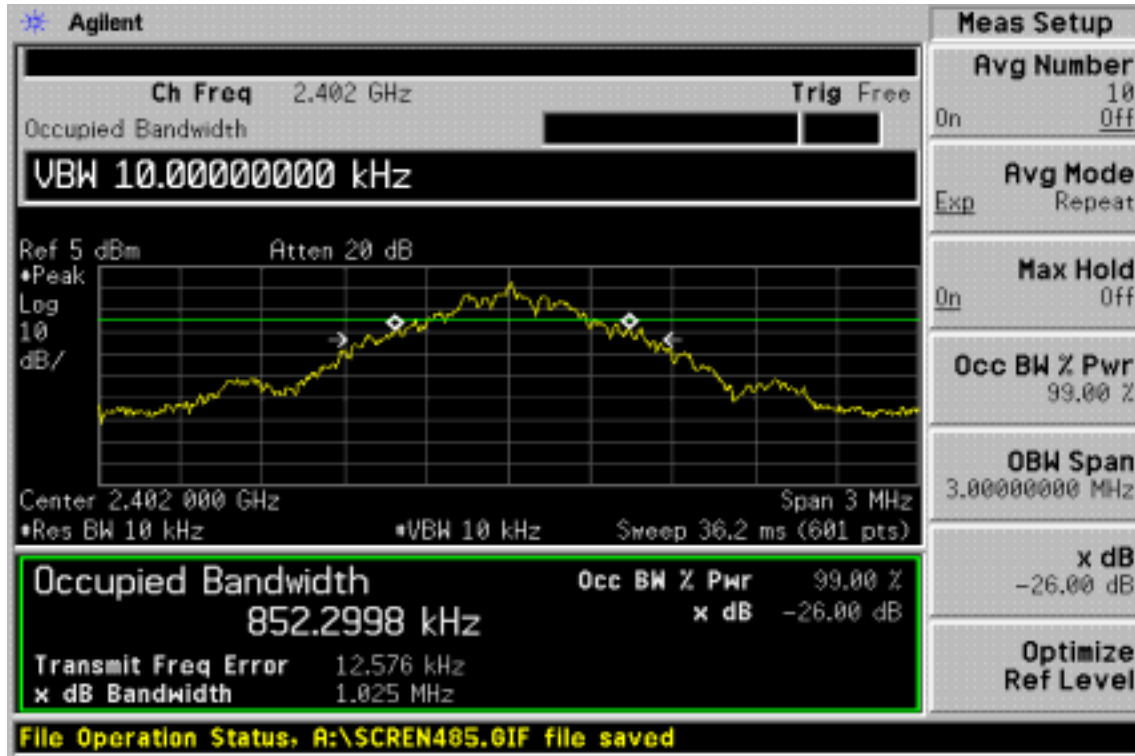

99% Band Width Test Data CH-Mid

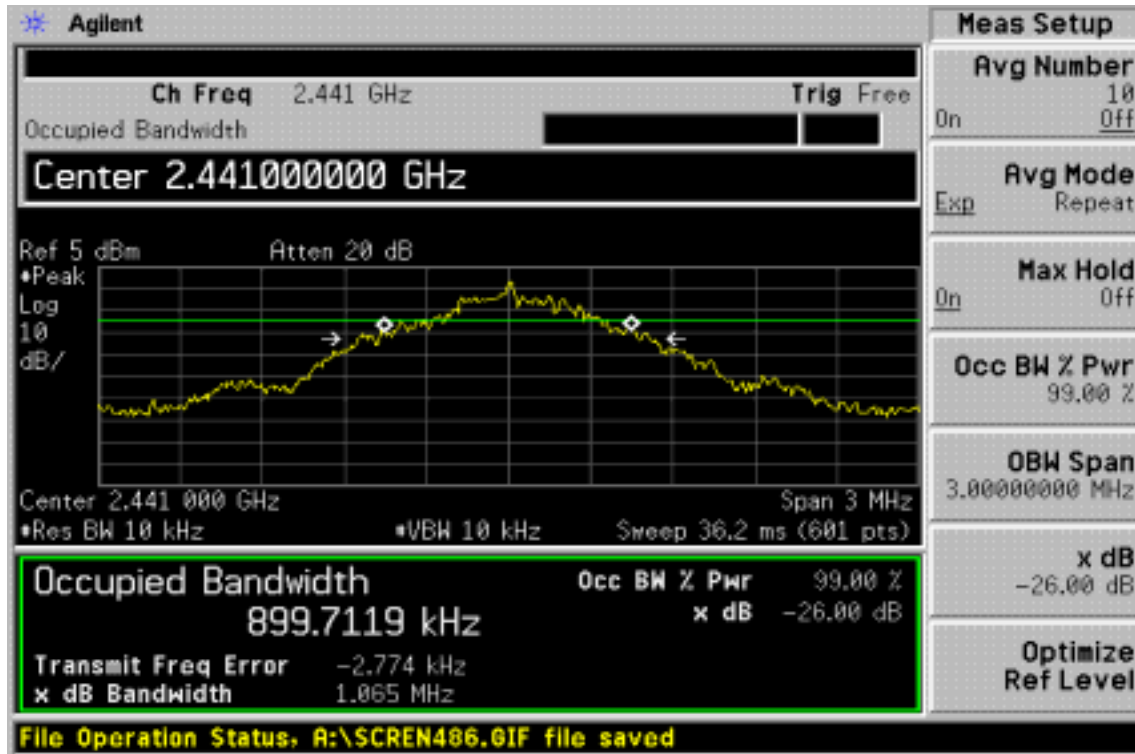

The results shown in this test report refer only to the sample(s) tested unless otherwise stated. This test report cannot be reproduced, except in full, without prior written permission of the Company.

99% Band Width Test Data CH-High

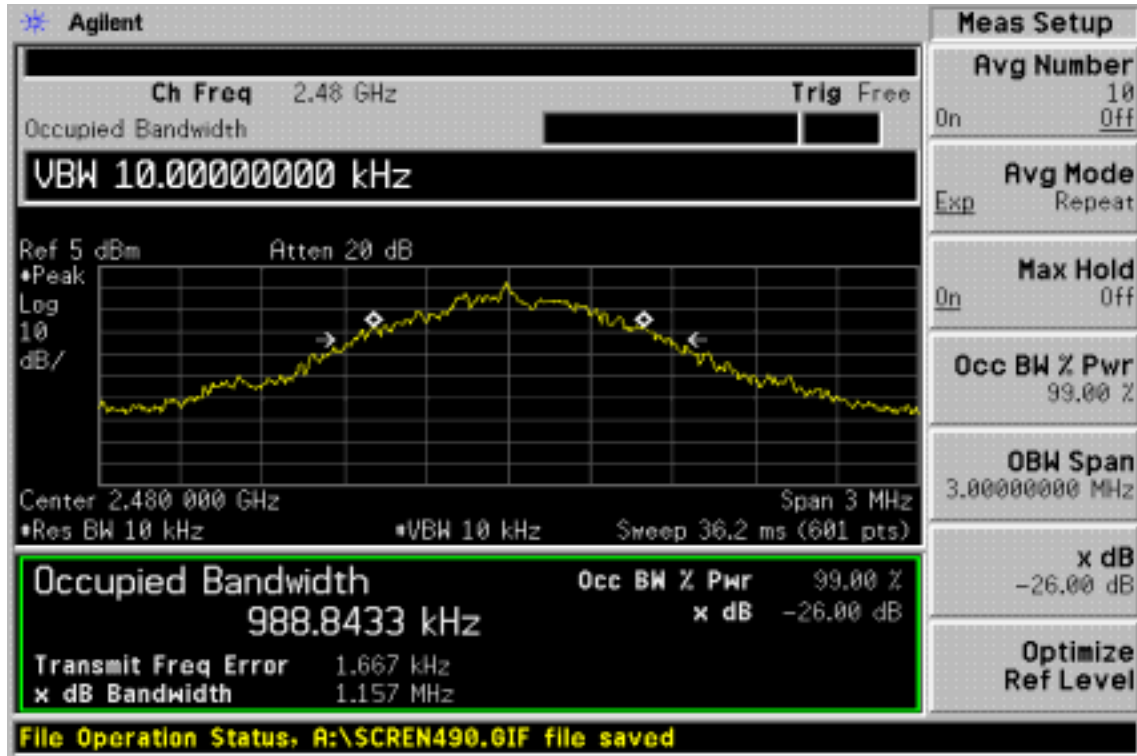

The results shown in this test report refer only to the sample(s) tested unless otherwise stated. This test report cannot be reproduced, except in full, without prior written permission of the Company.

15. ANTENNA REQUIREMENT

15.1. Standard Applicable

According to §15.203, an intentional radiator shall be designed to ensure that no antenna other than furnished by the responsible party shall be used with the device.

And according to §15.246(1), if transmitting antennas of directional gain greater than 6dBi are used the power shall be reduced by the amount in dB that the directional gain of the antenna exceeds 6 dBi.

According to §RSS 210 , section 5.5, The transmitter antenna shall be integral with the device, or the antenna coupling be so designed that no antenna other than that furnished by the party responsible for compliance shall be used.

15.2. Antenna Connected Construction

The directional gains of antenna used for transmitting is 0.21 dBi, and the antenna connector is designed with permanent attachment and no consideration of replacement. Please see EUT photo for details.

The results shown in this test report refer only to the sample(s) tested unless otherwise stated. This test report cannot be reproduced, except in full, without prior written permission of the Company.

16. RF EXPOSURE

16.1. Standard Applicable

According to §1.1307(b)(1), systems operating under the provisions of this section shall be operated in a manner that ensure that the public is not exposed to radio frequency energy level in excess of the Commission's guideline.

This is a Mobile device, the MPE is required.

According to §1.1310 and §2.1093 RF exposure is calculated.

Limits for Maximum Permissible Exposure (MPE)

Frequency Range (MHz)	Electric Field Strength (V/m)	Magnetic Field Strength (A/m)	Power Density (mW/cm ²)	Averaging Time (minute)
Limits for General Population/Uncontrolled Exposure				
0.3-1.34	614	1.63	*(100)	30
1.34-30	824/f	2.19/f	*(180/f ²)	30
30-300	27.5	0.073	0.2	30
300-1500	/	/	F/1500	30
1500-15000	/	/	1.0	30

F = frequency in MHz

* = Plane-wave equipment power density

MPE Prediction

Prediction of MPE limit at a given distance

Equation from page 18 of OET Bulletin 65, Edition 97-01

$$S = PG/4 R^2$$

Where: S = Power density

P = Power input to antenna

G = Power gain of the antenna in the direction of interest relative to an isotropic radiator

R = Distance to the center of radiation of the antenna

The results shown in this test report refer only to the sample(s) tested unless otherwise stated. This test report cannot be reproduced, except in full, without prior written permission of the Company.

Maximum peak output power at antenna input terminal:	1.83	(dBm)
Maximum peak output power at antenna input terminal:	1.524053	(mW)
Antenna gain (typical):	2	(dBi)
Maximum antenna gain:	1.584893	(numeric)
Prediction distance:	20	(cm)
Prediction frequency:	2402	(MHz)
MPE limit for uncontrolled exposure at prediction	1	(mW/cm ²)
Power density at predication frequency at 20 (cm)	0.000481	(mW/cm ²)
Measurement Result:		
The predicted power density level at 20 cm is	0.000481	(mW/cm ²)
This is below the uncontrolled exposure limit of 1 mW/cm	2402	MHz

16.2. Measurement Result

The predicted power density level at 20 cm is 0.000481 mW/cm². This is below the uncontrolled exposure limit of 1 mW/cm² at 2402MHz

The results shown in this test report refer only to the sample(s) tested unless otherwise stated. This test report cannot be reproduced, except in full, without prior written permission of the Company.

APPENDIX 1

PHOTOGRPHS OF SET UP

The results shown in this test report refer only to the sample(s) tested unless otherwise stated. This test report cannot be reproduced, except in full, without prior written permission of the Company.

Radiated Emission Set up Photos



The results shown in this test report refer only to the sample(s) tested unless otherwise stated. This test report cannot be reproduced, except in full, without prior written permission of the Company.

APPENDIX 2

PHOTOGRPHS OF EUT

The results shown in this test report refer only to the sample(s) tested unless otherwise stated. This test report cannot be reproduced, except in full, without prior written permission of the Company.

All View of EUT



Front View of EUT



The results shown in this test report refer only to the sample(s) tested unless otherwise stated. This test report cannot be reproduced, except in full, without prior written permission of the Company.

Back View of EUT



Right Side of EUT



The results shown in this test report refer only to the sample(s) tested unless otherwise stated. This test report cannot be reproduced, except in full, without prior written permission of the Company.

Left Side of EUT*Front View of EUT*

The results shown in this test report refer only to the sample(s) tested unless otherwise stated. This test report cannot be reproduced, except in full, without prior written permission of the Company.

Back View of EUT

The results shown in this test report refer only to the sample(s) tested unless otherwise stated. This test report cannot be reproduced, except in full, without prior written permission of the Company.

Open View of EUT



Internal of EUT - 1

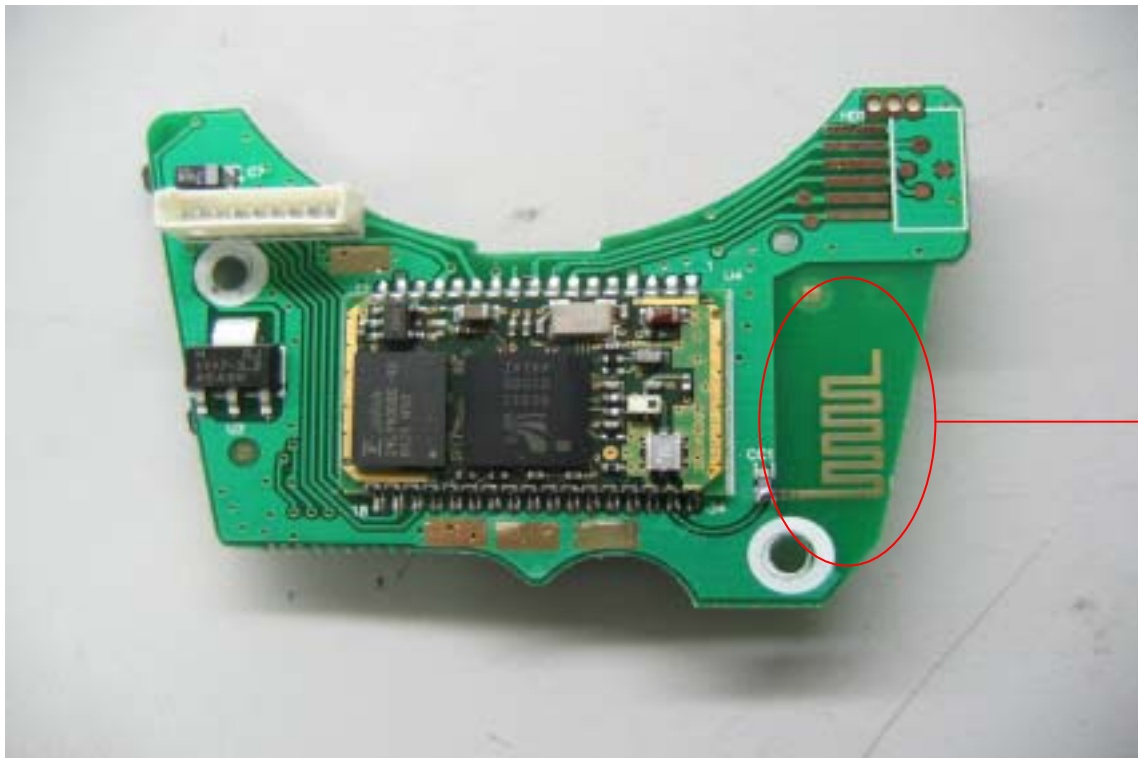

Ant

The results shown in this test report refer only to the sample(s) tested unless otherwise stated. This test report cannot be reproduced, except in full, without prior written permission of the Company.

Internal of EUT - 2



Internal of EUT - 3



The results shown in this test report refer only to the sample(s) tested unless otherwise stated. This test report cannot be reproduced, except in full, without prior written permission of the Company.

Internal of EUT - 4



Open View of EUT



The results shown in this test report refer only to the sample(s) tested unless otherwise stated. This test report cannot be reproduced, except in full, without prior written permission of the Company.

Internal of EUT



The results shown in this test report refer only to the sample(s) tested unless otherwise stated. This test report cannot be reproduced, except in full, without prior written permission of the Company.