



BNetzA-CAB-21/21-21

# Test Report

**Test report no.:** 19113662-17866-3

**Date of issue:** 2021-05-02

**Test result:** The test item - **passed** - and complies with below listed standards.

## Applicant

TeraTron GmbH

## Manufacturer

TeraTron GmbH

## Test Item

KR0304

## RF-Spectrum Testing

according to:

FCC 47 CFR Part 15

Radio Frequency Devices (Subpart C)

RSS-Gen

General Requirements for Compliance of Radio Apparatus

Tested by  
(name, function, signature)

*Karsten Gerdly*  
Head of Laboratory RF

  
signature

Approved by  
(name, function, signature)

*Dr.-Ing. Harald Ansorge*  
Managing Director

  
signature

<b>Applicant and Test item details</b>	
<b>Applicant</b>	TeraTron GmbH Martin-Siebert-Str. 5 51647, Gummersbach, Germany
<b>Manufacturer</b>	TeraTron GmbH Martin-Siebert-Str. 5 51647, Gummersbach, Germany
<b>Test item description</b>	Desktop KeyReader Plus
<b>Model/Type reference</b>	KR0304
<b>FCC ID</b>	QLXKR0304
<b>IC</b>	4430A-KR0304
<b>PMN</b>	Desktop KeyReader Plus
<b>HVIN</b>	KR0304
<b>FVIN</b>	N/A
<b>HMN</b>	N/A
<b>Frequency</b>	125 kHz
<b>Antenna</b>	Integrated ferrite coil antenna
<b>Power supply</b>	5.0 V DC via USB connection from PC
<b>Temperature range</b>	0 °C – +45 °C

### Disclaimer and Notes

The content of this report relates to the mentioned test sample(s) only.  
Without a written permit of IBL-Lab GmbH, this test report shall not be reproduced, except in full.

The last valid version is available at TAMSys®.  
Copyright ©: All rights reserved by IBL-Lab GmbH

Within this test report, a  point /  comma is used as a decimal separator.  
If otherwise, a detailed note is added adjected to its use.

IBL-Lab GmbH does not take test samples. The sample used for testing is provided by the applicant.

Decision rule: Binary Statement for Simple Acceptance Rule according ILAC-G8:09/2019

# 1 TABLE OF CONTENTS

1	TABLE OF CONTENTS .....	3
2	GENERAL INFORMATION .....	4
2.1	Administrative details .....	4
2.2	Possible test case verdicts .....	4
2.3	Observations .....	4
2.4	Opinions and interpretations .....	4
2.5	Revision History .....	6
2.6	Further documents .....	6
3	ENVIRONMENTAL & TEST CONDITIONS .....	7
3.1	Environmental conditions .....	7
3.2	Normal and extreme test conditions .....	7
4	TEST STANDARDS AND REFERENCES .....	7
5	EQUIPMENT UNDER TEST (EUT) .....	8
5.1	Product description .....	8
5.2	Description of test item .....	8
5.3	Technical data of test item .....	8
5.4	Additional information .....	8
6	Test Setup Description .....	9
6.1	Semi Anechoic Chamber with Ground Plane .....	10
6.2	AC conducted .....	12
7	Measurement procedures .....	13
7.1	Radiated spurious emissions from 9 kHz to 30 MHz .....	13
7.2	Radiated spurious emissions from 30 MHz to 1 GHz .....	14
8	SUMMARY OF TEST RESULTS .....	15
9	TEST RESULTS .....	16
9.1	Conducted emissions .....	16
9.2	Field strength of emissions .....	19
9.3	Occupied bandwidth .....	22
10	MEASUREMENT UNCERTAINTIES .....	25

## 2 GENERAL INFORMATION

### 2.1 Administrative details

Testing laboratory	<b>IBL-Lab GmbH</b> Heinrich-Hertz-Allee 7 66386 Sankt Ingbert / Germany Fon: +49 6894 38938-0 Fax: +49 6894 38938-99 URL: <a href="http://www.ib-lenhardt.de">www.ib-lenhardt.de</a> E-Mail: <a href="mailto:info@ib-lenhardt.de">info@ib-lenhardt.de</a>
Accreditation	The testing laboratory is accredited by Deutsche Akkreditierungsstelle GmbH (DAkkS) in compliance with DIN EN ISO/IEC 17025:2018.  Scope of testing and registration number: <ul style="list-style-type: none"> <li>• Electromagnetic Compatibility and Telecommunication (FCC requirements) <a href="#">D-PL-21375-01-03</a></li> <li>• Telecommunication (TC) and Electromagnetic Compatibility (EMC) for Canadian Standards <a href="#">D-PL-21375-01-04</a></li> </ul> Website DAkkS: <a href="https://www.dakks.de/">https://www.dakks.de/</a>  The Deutsche Akkreditierungsstelle GmbH (DAkkS) is also a signatory to <a href="#">ILAC Mutual Recognition Arrangement</a>
Testing location	<b>IBL-Lab GmbH</b> Heinrich-Hertz-Allee 7 66386 St. Ingbert / Germany
Date of receipt of test samples	2021-02-01
Start – End of tests	2021-02-17 – 2021-03-09

### 2.2 Possible test case verdicts

Test sample meets the requirements	P (PASS)
Test sample does not meet the requirements	F (FAIL)
Test case does not apply to the test sample	N/A (Not applicable)
Test case not performed	N/P (Not performed)

### 2.3 Observations

No additional observations other than the reported observations within this test report have been made.

### 2.4 Opinions and interpretations

No appropriate opinions or interpretations according ISO/IEC 17025:2017 clause 7.8.7 are within this test report.

## 2.5 Revision History

### -1 Initial Version

**-2 Revision:** technical modification

Measurement result for occupied bandwidth included.

**-3 Revision:** administrative modifications / corrections

Internal review and editorial changes, accreditation symbol changed.

**The present test report 19113662-17866-3 replaces the previous test report 19113662-17866-2. Utilisation, publication and control of previous report editions is under responsibility of the applicant.**

## 2.6 Further documents

List of further applicable documents belonging to the present test report:

External EUT photographs: 19113662-17866\_AnnexA

Internal EUT photographs: 19113662-17866\_AnnexB

Test setup photographs: 19113662-17866\_AnnexC

### 3 ENVIRONMENTAL & TEST CONDITIONS

#### 3.1 Environmental conditions

Temperature	20°C ± 5°C
Relative humidity	25-75% r.H.
Barometric Pressure	860-1060 mbar
Power supply	230 V AC ± 5%

#### 3.2 Normal and extreme test conditions

	minimum	nominal	maximum
Temperature	-/-	+22 °C	-/-
Relative humidity	-/-	45 % r.h.	-/-
Power supply	-/-	110 V AC	-/-

### 4 TEST STANDARDS AND REFERENCES

Test standard (accredited)	Description
FCC 47 CFR Part 15	Radio Frequency Devices (Subpart C)
RSS-Gen	General Requirements for Compliance of Radio Apparatus

Reference	Description
ANSI C63.4-2014	American National Standard for Methods of Measurement of Radio-Noise Emissions from Low-Voltage Electrical and Electronic Equipment in the Range of 9 kHz to 40 GHz
ANSI C63.10-2013	American National Standard of Procedures for Compliance Testing of Unlicensed Wireless Devices

## 5 EQUIPMENT UNDER TEST (EUT)

### 5.1 Product description

Desktop KeyReader Plus

### 5.2 Description of test item

<b>Model name*</b>	KR0304
<b>Serial number*</b>	351826
<b>PCB identifier*</b>	0304.01.03
<b>Hardware status*</b>	03
<b>Software status*</b>	01.11

\*: as declared by applicant

### 5.3 Technical data of test item

<b>Operational carrier frequency*</b>	125 kHz
<b>Operational frequency band*</b>	125 kHz band
<b>Type of radio transmission*</b>	Modulated carrier
<b>Modulation type*</b>	ASK (OOK)
<b>Number of channels*</b>	1
<b>Channel bandwidth*</b>	<15 kHz
<b>Channel spacing*</b>	n.a.
<b>Receiver category*</b>	n.a.
<b>Receiver bandwidth*</b>	n.a.
<b>Duty cycle*</b>	1128 ms on / 337 ms off, i.e. DC = 77%
<b>Antenna*</b>	Integrated ferrite coil antenna
<b>Power supply*</b>	5.0 V DC via USB connection from PC
<b>Temperature range*</b>	0 °C – +45 °C

\*: as declared by applicant

### 5.4 Additional information

<b>Model differences</b>	None
<b>Ancillaries tested with</b>	AC/DC-Adapter: I.T.E. Power Supply, FW8002USB/05
<b>Additional equipment used for testing</b>	Notebook with test software

## 6 Test Setup Description

Typically, the calibrations of the test apparatus are commissioned to and performed by an accredited calibration laboratory. The calibration intervals are determined in accordance with the DIN EN ISO/IEC 17025. In addition to the external calibrations, the laboratory executes comparison measurements with other calibrated test systems or effective verifications. Cyclically chamber inspections and range calibrations are performed. Where possible resp. necessary, RF generating and signaling equipment as well as measuring receivers and analyzers are connected to an external high-precision 10 MHz reference (GPS-based frequency standard).

In order to simplify the identification of the equipment used at some special tests, some items of test equipment and ancillaries can be provided with an identifier or number in the equipment list below (Lab/Item).



## 6.1 Semi Anechoic Chamber with Ground Plane

Radiated measurements are performed in vertical and horizontal plane in the frequency range 30 MHz to 1 GHz in a Semi Anechoic Chamber with a metallic ground plane. The EUT is positioned on a non-conductive test table with a height of 0.80 m above the metallic ground plane that covers the whole chamber. The receiving antennas conform to specification ANSI C63.10-2013, American National Standard for Testing Unlicensed Wireless Devices. These antennas can be moved over the height range between 1.0 m and 4.5 m in order to search for maximum field strength emitted from the EUT. The measurement distances between EUT and receiving antennas are indicated in the test setups for the various frequency ranges. For each measurement, the EUT is rotated in all three axes until the maximum field strength is received. The wanted and unwanted emissions are received by a spectrum analyzer where the detector modes and resolution bandwidths over various frequency ranges are set according to requirement ANSI C63.

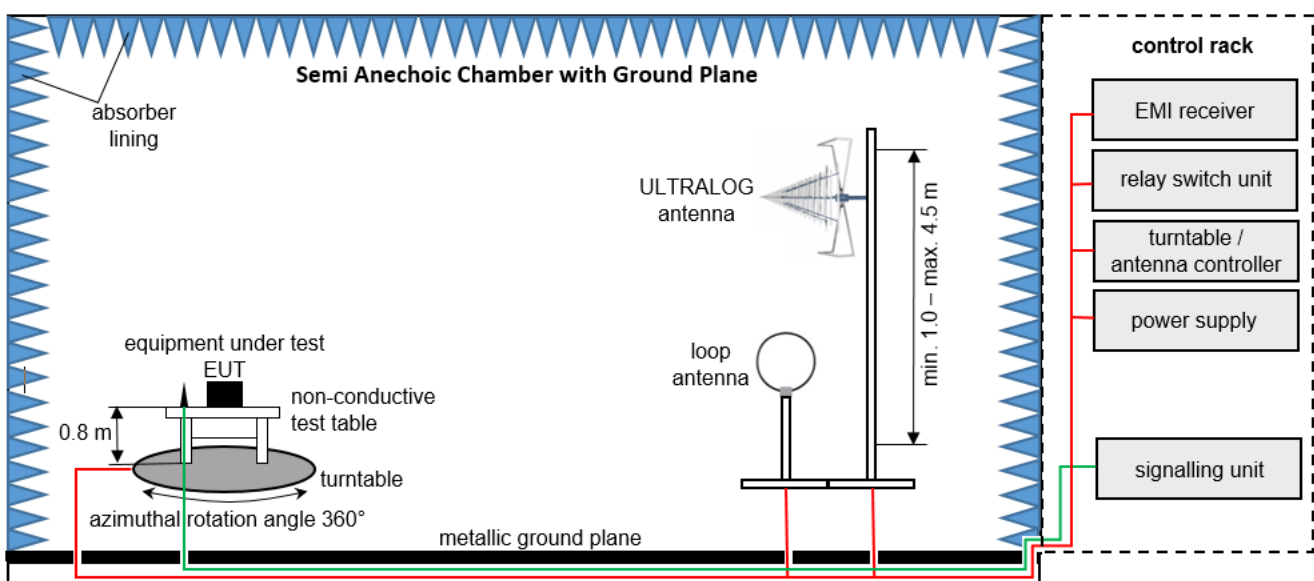

Measurement distance: ULTRALOG antenna 3 m; loop antenna 3 m  
EMC32 software version: 11.10.00

$$FS = UR + CL + AF$$

(FS-field strength; UR-voltage at the receiver; CL-loss of the cable; AF-antenna factor)

Example calculation:

$$FS \text{ [dB}\mu\text{V/m]} = 12.35 \text{ [dB}\mu\text{V/m]} + 1.90 \text{ [dB]} + 16.80 \text{ [dB/m]} = 31.05 \text{ [dB}\mu\text{V/m]} \text{ (35.69 } \mu\text{V/m)}$$

**List of test equipment used:**

No.	Equipment	Manufacturer	Type	Serial No.	IBL No.	Kind of Calibration	Last / Next Calibration
1	Power Supply	Elektro-Automatik GmbH & Co. KG	EA-PSI 9080-40 T	2000230001	LAB000313	NE	–
2	Test table	innco systems GmbH	PT1208-080-RH	-	LAB000306	NE	–
3	Positioner	matur GmbH	TD 1.5-10KG		LAB000258	NE	–
4	Compressed Air	Implotex	1-850-30	-	LAB000256	NE	–
5	EMI Test Receiver	Rohde & Schwarz	ESW26	101481	LAB000236	K	2020-06-03 → 12M → 2021-06-03
6	Semi-Anechoic Chamber (SAC)	Albatross Projects GmbH	SAC 5 (Babylon 5)	20168.PR.B	LAB000235	ZW	2020-08-24 → 12M → 2021-08-24
7	Measurement Software	Rohde & Schwarz	EMC32 V11.00.10		LAB000226	NE	–
8	Turntable	matur GmbH	TT2.0-2t	TT2.0-2t/921	LAB000225	NE	–
9	Antenna Mast	matur GmbH	CAM4.0-P	CAM4.0-P/316	LAB000224	NE	–
10	Antenna Mast	matur GmbH	BAM4.5-P	BAM4.5-P/272	LAB000223	NE	–
11	Controller	matur GmbH	FCU 3.0	10082	LAB000222	NE	–
12	Power Supply	Elektro-Automatik GmbH & Co. KG	PS 2042-10 B	2878350292	LAB000191	NE	–
13	Open Switch and Control Platform	Rohde & Schwarz	OSP200 Base Unit 2HU	101748	LAB000149	ZW	2020-07-07 → 12M → 2021-07-07
14	Antenna	Rohde & Schwarz	HF907	102898	LAB000124	K	2020-04-23 → 36M → 2023-04-23
15	Antenna	Rohde & Schwarz	HL562E	102001	LAB000123	K	2020-07-05 → 36M → 2023-07-05
16	Antenna	Rohde & Schwarz	HFH2-Z2E - Active Loop Antenna	100954	LAB000108	K	2020-03-25 → 36M → 2023-03-25
17	Pre-Amplifier	Schwarzbeck Mess-Elektronik OHG	BBV 9718 C	84	LAB000169	NE	–

## 6.2 AC conducted

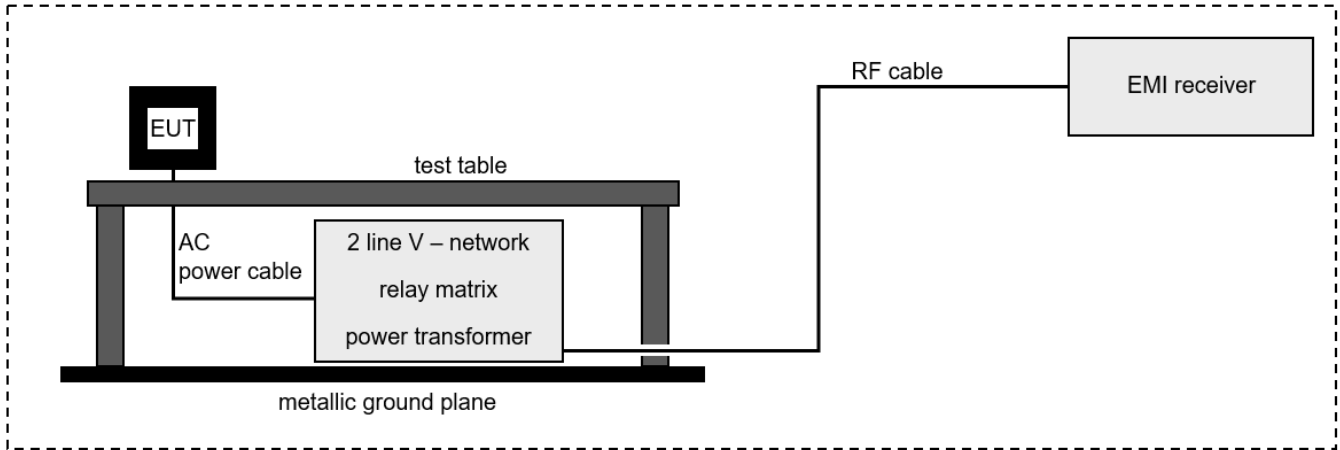

$$FS = UR + CF + VC$$

(FS-field strength; UR-voltage at the receiver; CR-loss of the cable and filter; VC-correction factor of the ISN)

Example calculation:

$$FS [dB\mu V/m] = 37.62 [dB\mu V/m] + 9.90 [dB] + 0.23 [dB] = 47.75 [dB\mu V/m] (244.06 \mu V/m)$$

**List of test equipment used:**

No.	Equipment	Manufacturer	Type	Serial No.	IBL No.	Kind of Calibration	Last / Next Calibration
1	Open Switch and Control Platform	Rohde & Schwarz	OSP-B200S2	101443	LAB000239	ZW	2020-07-07 → 12M → 2021-07-07
2	EMI Test Receiver	Rohde & Schwarz	ESW26	101481	LAB000236	K	2020-06-03 → 12M → 2021-06-03
3	Two-Line V-Network	Rohde & Schwarz	ENV216	102597	LAB000220	K	2020-09-17 → 24M → 2022-09-17

## 7 Measurement procedures

### 7.1 Radiated spurious emissions from 9 kHz to 30 MHz

#### Test setup

- The EUT is set up according to its intended use, as described in the user manual or as defined by the manufacturer.
- In case of floor standing equipment, it is placed in the middle of the turn table.  
In case of tabletop equipment it is placed on a non-conductive table with a height of 80 cm.
- Additional equipment, cables, ... necessary for testing, are positioned like under normal operation.
- Interface cables, e.g. power supply, network, ... are connected to the connection box in the turn table.
- EUT is powered on and set into operation.

#### Pre-scan

- Turntable performs an azimuthal rotation from 0° to 315° in 45° steps.
- For each turntable step the EMI-receiver/spectrum analyser performs a positive-peak/max-hold sweep (=worst-case). Data is transferred to EMI-software and recorded. EMI-software will show the maximum level of all single sweeps as the final result for the pre-scan.

#### Final measurement

- Significant emissions found during the pre-scan will be maximized by the EMI-software by rotating the turntable from 0° to 360°.
- Loop antenna is rotated with special 3D adapter set to find maximum level of emissions.
- Plot of the pre-scan with frequencies of identified emissions including levels, correction factors, turn table position and settings of measuring equipment is recorded.

Detailed requirements can be found in e.g. ANSI C63.4 / C63.10

## 7.2 Radiated spurious emissions from 30 MHz to 1 GHz

### Test setup

- The EUT is set up according to its intended use, as described in the user manual or as defined by the manufacturer.
- In case of floor standing equipment, it is placed in the middle of the turn table.  
In case of tabletop equipment it is placed on a non-conductive table with a height of 80 cm.
- Additional equipment, cables, ... necessary for testing, are positioned like under normal operation.
- Interface cables, e.g. power supply, network, ... are connected to the connection box in the turn table.
- EUT is powered on and set into operation.

### Pre-scan

- Turntable performs an azimuthal rotation from 0° to 315° in 45° steps.
- Antenna polarisation is changed (H-V / V-H) and antenna height is changed from 1 meter to 4 meters.
- For each turntable step / antenna polarisation / antenna height the EMI-receiver/spectrum analyser performs a positive-peak/max-hold sweep (=worst-case). Data is transferred to EMI-software and recorded. EMI-software will show the maximum level of all single sweeps as the final result for the pre-scan.

### Final measurement

- Significant emissions found during the pre-scan will be maximized by the EMI-software based on evaluated data during the pre-scan by rotating the turntable and changing antenna height and polarisation.
- Final measurement will be performed with measuring equipment settings as defined in the applicable test standards (e.g. ANSI C6.4).
- Plot of the pre-scan with frequencies of identified emissions including levels, correction factors, turn table position, antenna polarisation and settings of measuring equipment is recorded.

Detailed requirements can be found in e.g. ANSI C63.4 / C63.10

## 8 SUMMARY OF TEST RESULTS

### Test specification

FCC 47 CFR Part 15  
RSS-Gen

Clause	Requirement / Test case	Test Conditions	Result / Remark	Verdict
§15.207 RSS-Gen	Conducted limits	Normal	< limit	P
§15.209 RSS-Gen	Radiated emission limits	Normal	< limit	P
RSS-Gen, 6.7	Occupied bandwidth	Normal	13.137 kHz	P

### Notes

none

### Comments and observations

none

## 9 TEST RESULTS

### 9.1 Conducted emissions

#### Description / Limits

§15.207 (a) Except as shown in paragraphs (b) and (c) of this section, for an intentional radiator that is designed to be connected to the public utility (AC) power line, the radio frequency voltage that is conducted back onto the AC power line on any frequency or frequencies, within the band 150 kHz to 30 MHz, shall not exceed the limits in the following table, as measured using a 50 µH/50 ohms line impedance stabilization network (LISN). Compliance with the provisions of this paragraph shall be based on the measurement of the radio frequency voltage between each power line and ground at the power terminal. The lower limit applies at the boundary between the frequency ranges.

Frequency of emission [MHz]	Conducted limit [dBµV]	
	Quasi-Peak	Average
0.15 – 0.5	66 to 56*	56 to 46*
0.5 – 5.0	56	46
5.0 – 30	60	50

\*Decreases with the logarithm of the frequency.

§15.207 (c) Measurements to demonstrate compliance with the conducted limits are not required for devices which only employ battery power for operation and which do not operate from the AC power lines or contain provisions for operation while connected to the AC power lines. Devices that include, or make provisions for, the use of battery chargers which permit operating while charging, AC adapters or battery eliminators or that connect to the AC power lines indirectly, obtaining their power through another device which is connected to the AC power lines, shall be tested to demonstrate compliance with the conducted limits.

**Test setup:** see 6.2

#### Test results

See next pages!

#### Note:

Testing was performed with a test mode comparable to normal operation mode for 125 kHz active.

Plot no. 1: conducted emissions, line L1

Full Spectrum

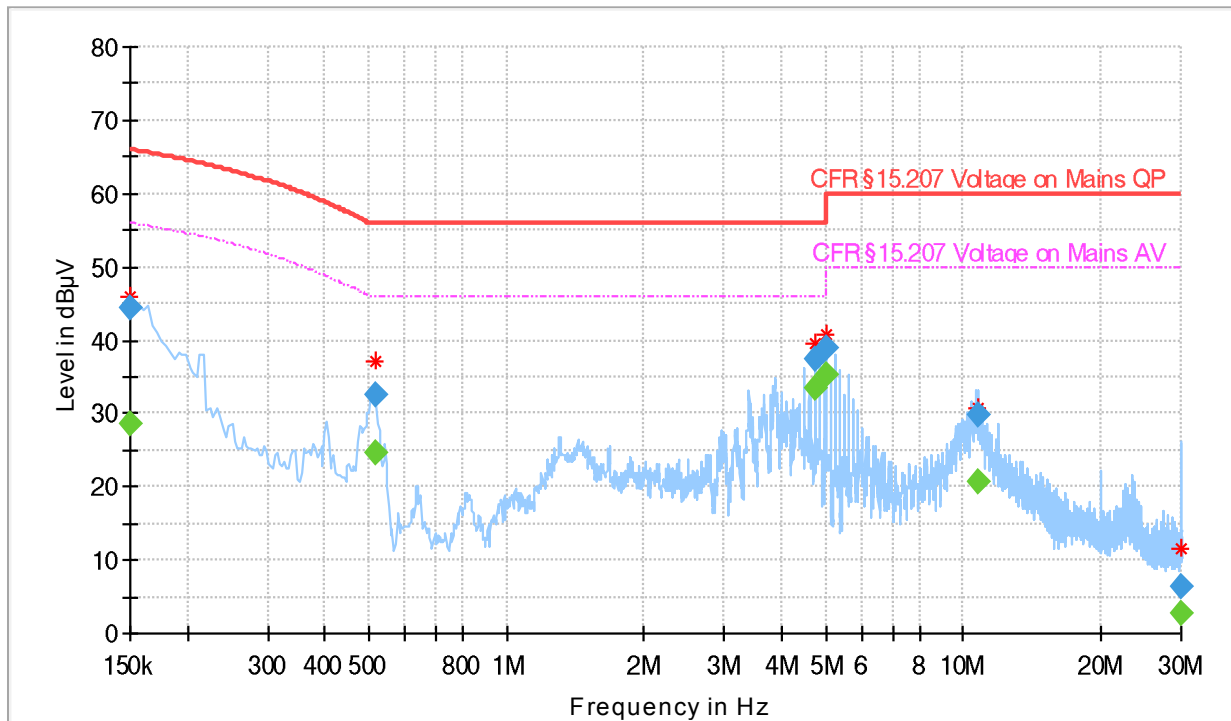

### Final Result

Frequency (MHz)	QuasiPeak (dBµV)	Average (dBµV)	Limit (dBµV)	Margin (dB)	Meas. Time (ms)	Bandwidth (kHz)	Line	Corr. (dB)
0.150658	---	28.52	55.98	27.46	15000.0	9.000	L1	10.8
0.150658	44.32	---	65.98	21.67	15000.0	9.000	L1	10.8
0.516058	---	24.52	46.00	21.48	15000.0	9.000	L1	10.1
0.516058	32.50	---	56.00	23.50	15000.0	9.000	L1	10.1
4.739530	---	33.32	46.00	12.68	15000.0	9.000	L1	10.0
4.739530	37.36	---	56.00	18.64	15000.0	9.000	L1	10.0
4.989752	---	35.37	46.00	10.63	15000.0	9.000	L1	10.0
4.989752	38.89	---	56.00	17.11	15000.0	9.000	L1	10.0
10.732536	---	20.67	50.00	29.33	15000.0	9.000	L1	10.2
10.732536	29.84	---	60.00	30.16	15000.0	9.000	L1	10.2
29.951112	---	2.69	50.00	47.31	15000.0	9.000	L1	10.6
29.951112	6.27	---	60.00	53.73	15000.0	9.000	L1	10.6



Plot no. 2: conducted emissions, neutral N

Full Spectrum

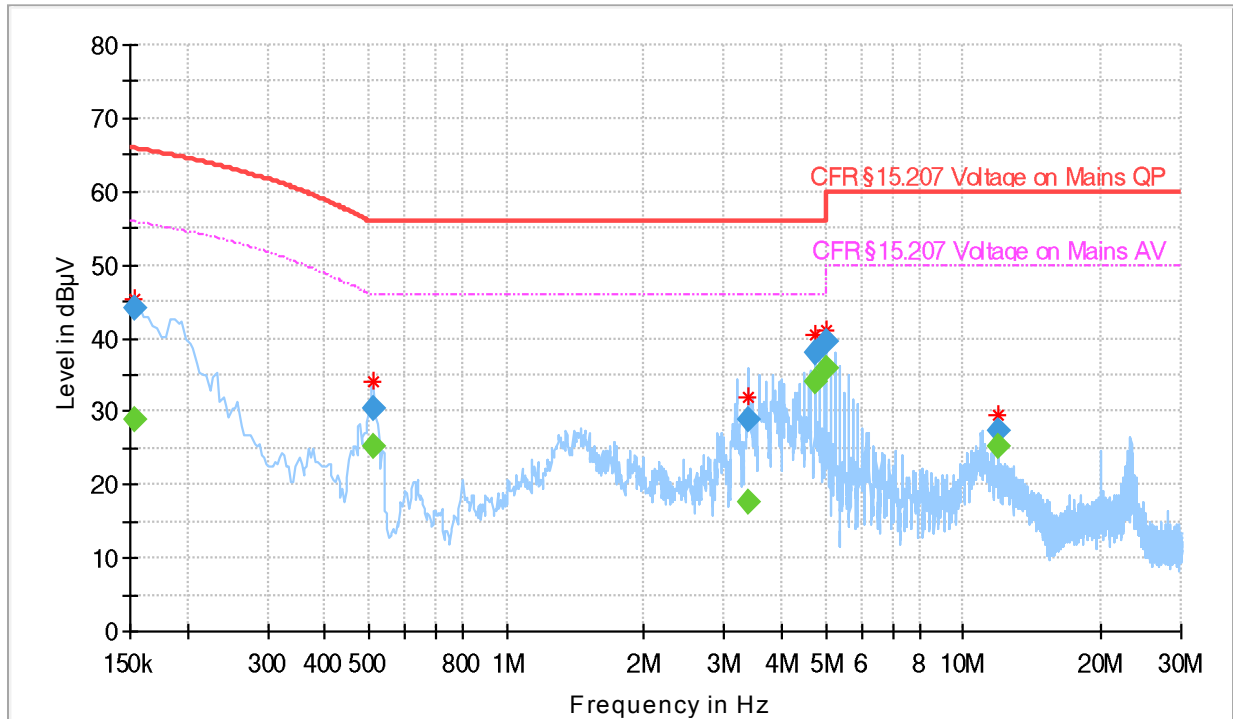

### Final Result

Frequency (MHz)	QuasiPeak (dBµV)	Average (dBµV)	Limit (dBµV)	Margin (dB)	Meas. Time (ms)	Bandwidth (kHz)	Line	Corr. (dB)
0.153272	---	29.00	55.91	26.91	15000.0	9.000	N	10.7
0.153272	44.25	---	65.91	21.65	15000.0	9.000	N	10.7
0.511118	---	25.19	46.00	20.81	15000.0	9.000	N	10.1
0.511118	30.41	---	56.00	25.59	15000.0	9.000	N	10.1
3.381454	---	17.73	46.00	28.27	15000.0	9.000	N	9.9
3.381454	28.91	---	56.00	27.09	15000.0	9.000	N	9.9
4.739939	---	33.93	46.00	12.07	15000.0	9.000	N	10.0
4.739939	37.95	---	56.00	18.05	15000.0	9.000	N	10.0
4.989934	---	35.91	46.00	10.09	15000.0	9.000	N	10.0
4.989934	39.41	---	56.00	16.59	15000.0	9.000	N	10.0
11.975718	---	25.31	50.00	24.69	15000.0	9.000	N	10.3
11.975718	27.33	---	60.00	32.67	15000.0	9.000	N	10.3

## 9.2 Field strength of emissions

### Description / Limits

§15.209 (a) Except as provided elsewhere in this subpart, the emissions from an intentional radiator shall not exceed the field strength levels specified in the following table:

Frequency	Field Strength	Measurement distance
0.009 – 0.490 MHz	2400/F[kHz] $\mu$ V/m	300 m
0.490 – 1.705 MHz	24000/F[kHz] $\mu$ V/m	30 m
1.705 – 30.0 MHz	30.0 $\mu$ V/m / 29.5 dB $\mu$ V/m	30 m
30 – 88 MHz	100 $\mu$ V/m / 40.0 dB $\mu$ V/m	3 m
88 – 216 MHz	150 $\mu$ V/m / 43.5 dB $\mu$ V/m	3 m
216 – 960 MHz	200 $\mu$ V/m / 46.0 dB $\mu$ V/m	3 m
960 – 100 000 MHz	500 $\mu$ V/m / 54.0 dB $\mu$ V/m	3 m

§15.209 (b) In the emission table above, the tighter limit applies at the band edges.

§15.209 (c) The level of any unwanted emissions from an intentional radiator operating under these general provisions shall not exceed the level of the fundamental emission. For intentional radiators which operate under the provisions of other sections within this part and which are required to reduce their unwanted emissions to the limits specified in this table, the limits in this table are based on the frequency of the unwanted emission and not the fundamental frequency. However, the level of any unwanted emissions shall not exceed the level of the fundamental frequency.

§15.209 (d) The emission limits shown in the above table are based on measurements employing a CISPR quasi-peak detector except for the frequency bands 9-90 kHz, 110-490 kHz and above 1000 MHz. Radiated emission limits in these three bands are based on measurements employing an average detector.

### Test procedure

§15.31 (m) Measurements on intentional radiators or receivers, other than TV broadcast receivers, shall be performed and, if required, reported for each band in which the device can be operated with the device operating at the number of frequencies in each band specified in the following table:

Frequency range	Number of frequencies	Location
< 1MHz bandwidth	1	middle
1 – 10 MHz bandwidth	2	1 near bottom and 1 near top
> 10 MHz bandwidth	3	1 near bottom / middle / top

§15.35 (a) On any frequency or frequencies below or equal to 1000 MHz, the limits shown are based on measuring equipment employing a CISPR quasi-peak detector function and related measurement bandwidths, unless otherwise specified. The specifications for the measuring instrumentation using the CISPR quasi-peak detector can be found in ANSI C63.4-2014, clause 4 (incorporated by reference, see §15.38). As an alternative to CISPR quasi-peak measurements, the responsible party, at its option, may demonstrate compliance with the emission limits using measuring equipment employing a peak detector function as long as the same bandwidth as indicated for CISPR quasi-peak measurements are employed.

**Test setup:** see 6.1

### Test results

Channel / Mode	Frequency [MHz]	Detector	Test distance [m]	Level [dB $\mu$ V/m]	Limit [dB $\mu$ V/m]	Margin [dB]
Test mode	0.124750	QP	3	95.78	105.69	9.91
	654.665000	QP	3	25.87	46.00	20.13
	662.665000	QP	3	25.74	46.00	20.26
	670.650000	QP	3	29.81	46.00	16.19

**Note:** Testing was performed with a test mode comparable to normal operation mode.

Plot no. 3: radiated emissions 9 kHz – 30 MHz, loop antenna

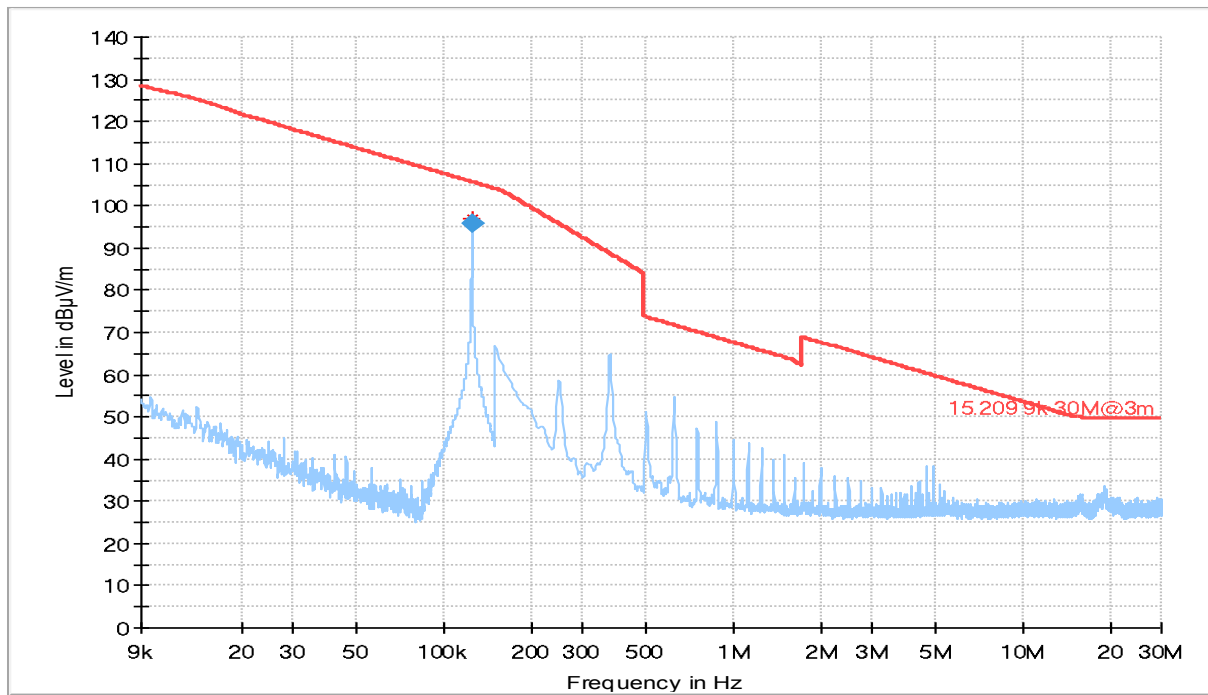

### Final Result

Frequency (MHz)	QuasiPeak (dBµV/m)	Limit (dBµV/m)	Margin (dB)	Meas. Time (ms)	Bandwidth (kHz)	Azimuth (deg)	Corr. (dB/m)
0.124750	95.78	105.69	9.91	100.0	0.200	10.0	20.5

Plot no. 4: radiated emissions 30 MHz – 1 GHz, hor./vert. polarization

Full Spectrum

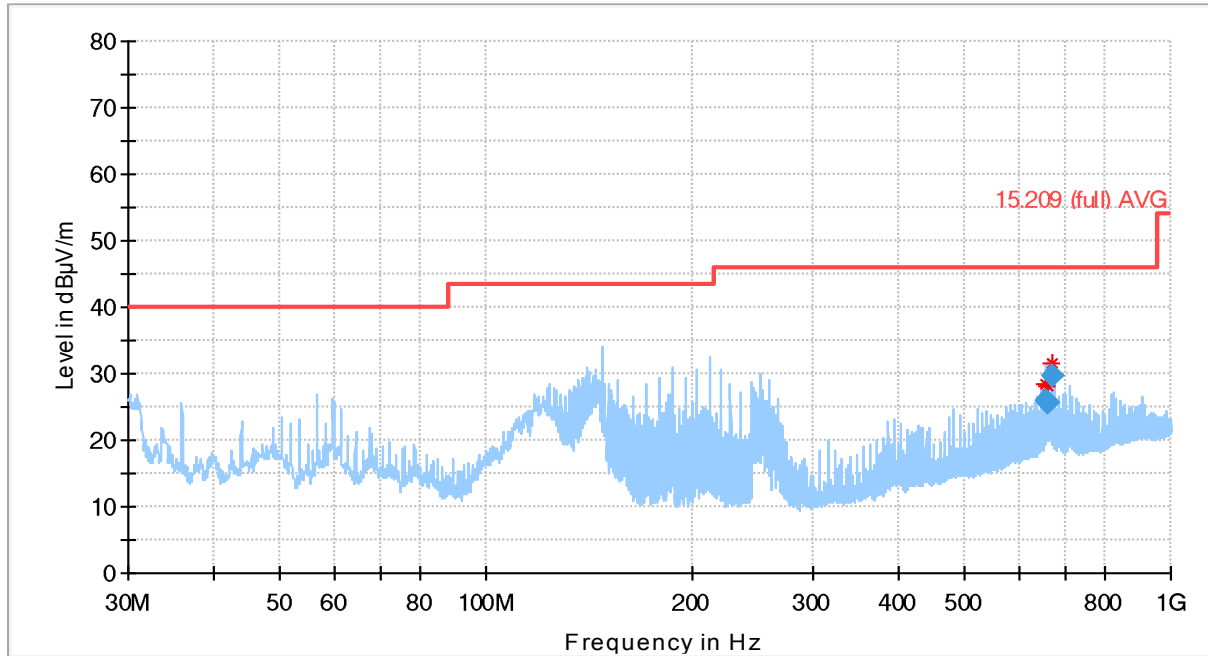

### Final Result

Frequency (MHz)	QuasiPeak (dBµV/m)	Limit (dBµV/m)	Margin (dB)	Meas. Time (ms)	Bandwidth (kHz)	Height (cm)	Pol	Azimuth (deg)
654.665000	25.87	46.00	20.13	100.0	120.000	100.0	V	161.0
662.665000	25.74	46.00	20.26	100.0	120.000	100.0	V	161.0
670.650000	29.81	46.00	16.19	100.0	120.000	100.0	V	182.0

### 9.3 Occupied bandwidth

#### Description

The occupied bandwidth or the “99% emission bandwidth” is defined as the frequency range between two points, one above and the other below the carrier frequency, within which 99% of the total transmitted power of the fundamental transmitted emission is contained. The occupied bandwidth shall be reported for all equipment in addition to the specified bandwidth required in the applicable RSSs.

In some cases, the “x dB bandwidth” is required, which is defined as the frequency range between two points, one at the lowest frequency below and one at the highest frequency above the carrier frequency, at which the maximum power level of the transmitted emission is attenuated x dB below the maximum in-band power level of the modulated signal, where the two points are on the outskirts of the in-band emission.

The following conditions shall be observed for measuring the occupied bandwidth and x dB bandwidth:

- The transmitter shall be operated at its maximum carrier power measured under normal test conditions.
- The span of the spectrum analyzer shall be set large enough to capture all products of the modulation process, including the emission skirts, around the carrier frequency, but small enough to avoid having other emissions (e.g. on adjacent channels) within the span.
- The detector of the spectrum analyzer shall be set to “Sample”. However, a peak, or peak hold, may be used in place of the sampling detector since this usually produces a wider bandwidth than the actual bandwidth (worst-case measurement). Use of a peak hold (or “Max Hold”) may be necessary to determine the occupied / x dB bandwidth if the device is not transmitting continuously.
- The resolution bandwidth (RBW) shall be in the range of 1% to 5% of the actual occupied / x dB bandwidth and the video bandwidth (VBW) shall not be smaller than three times the RBW value. Video averaging is not permitted.

**Note:** It may be necessary to repeat the measurement a few times until the RBW and VBW are in compliance with the above requirement.

For the 99% emission bandwidth, the trace data points are recovered and directly summed in linear power level terms. The recovered amplitude data points, beginning at the lowest frequency, are placed in a running sum until 0.5% of the total is reached, and that frequency recorded. The process is repeated for the highest frequency data points (starting at the highest frequency, at the right side of the span, and going down in frequency). This frequency is then recorded. The difference between the two recorded frequencies is the occupied bandwidth (or the 99% emission bandwidth).

#### Test procedure

ANSI C63.10, 6.9.3

The occupied bandwidth is the frequency bandwidth such that, below its lower and above its upper frequency limits, the mean powers are each equal to 0.5% of the total mean power of the given emission.

The following procedure shall be used for measuring 99% power bandwidth:

- a) The instrument center frequency is set to the nominal EUT channel center frequency. The frequency span for the spectrum analyzer shall be between 1.5 times and 5.0 times the OBW.
- b) The nominal IF filter bandwidth (3 dB RBW) shall be in the range of 1% to 5% of the OBW, and VBW shall be approximately three times the RBW, unless otherwise specified by the applicable requirement.
- c) Set the reference level of the instrument as required, keeping the signal from exceeding the maximum input mixer level for linear operation. In general, the peak of the spectral envelope shall be more than  $[10 \log(\text{OBW}/\text{RBW})]$  below the reference level. Specific guidance is given in 4.1.5.2.
- d) Step a) through step c) might require iteration to adjust within the specified range.
- e) Video averaging is not permitted. Where practical, a sample detection and single sweep mode shall be used. Otherwise, peak detection and max hold mode (until the trace stabilizes) shall be used.
- f) Use the 99% power bandwidth function of the instrument (if available) and report the measured bandwidth.
- g) If the instrument does not have a 99% power bandwidth function, then the trace data points are recovered and directly summed in linear power terms. The recovered amplitude data points, beginning at the lowest frequency, are placed in a running sum until 0.5% of the total is reached; that frequency is recorded as the lower frequency. The process is repeated until 99.5% of the total is reached; that frequency is recorded as the upper frequency. The 99% power bandwidth is the difference between these two frequencies.

h) The occupied bandwidth shall be reported by providing plot(s) of the measuring instrument display; the plot axes and the scale units per division shall be clearly labeled. Tabular data may be reported in addition to the plot(s).

**Note**

Measurements with the peak detector are also suitable to demonstrate compliance of an EUT, as long as the required resolution bandwidth is used, because peak detection will yield amplitudes equal to or greater than amplitudes measured with RMS detector. The measurement data from a spectrum analyser peak detector will represent the worst-case results (see ANSI C63.10).

**Test Parameters:**

Detector	Pos-Peak (worst-case)		
Trace-mode	Max Hold		
Resolution bandwidth RBW	300 Hz		
Video bandwidth	≥ RBW		
Span	see plots		
Sweep time	see plots		
Measurement uncertainty	±1 x 10 <sup>-7</sup>		
Test environment	Normal and extreme		
Test set-up	<input type="checkbox"/> Conducted	<input type="checkbox"/> Radiated	<input checked="" type="checkbox"/> Test Fixture

**Test Results:**

Channel	Min. Frequency F <sub>L</sub> [kHz]	Max. frequency F <sub>H</sub> [kHz]	Occupied bandwidth (99%) [kHz]
1	118.3425	131.4791	13.137

Where: F<sub>L</sub> = is the lower edge of the OBW  
 F<sub>H</sub> = is the upper edge of the OBW

<b>Verdict</b>	<b>- PASS -</b>	<i>Measurement plot(s) see next page(s).</i>
----------------	-----------------	--

<b>Comment</b>	
----------------	--

Plot No. 5:

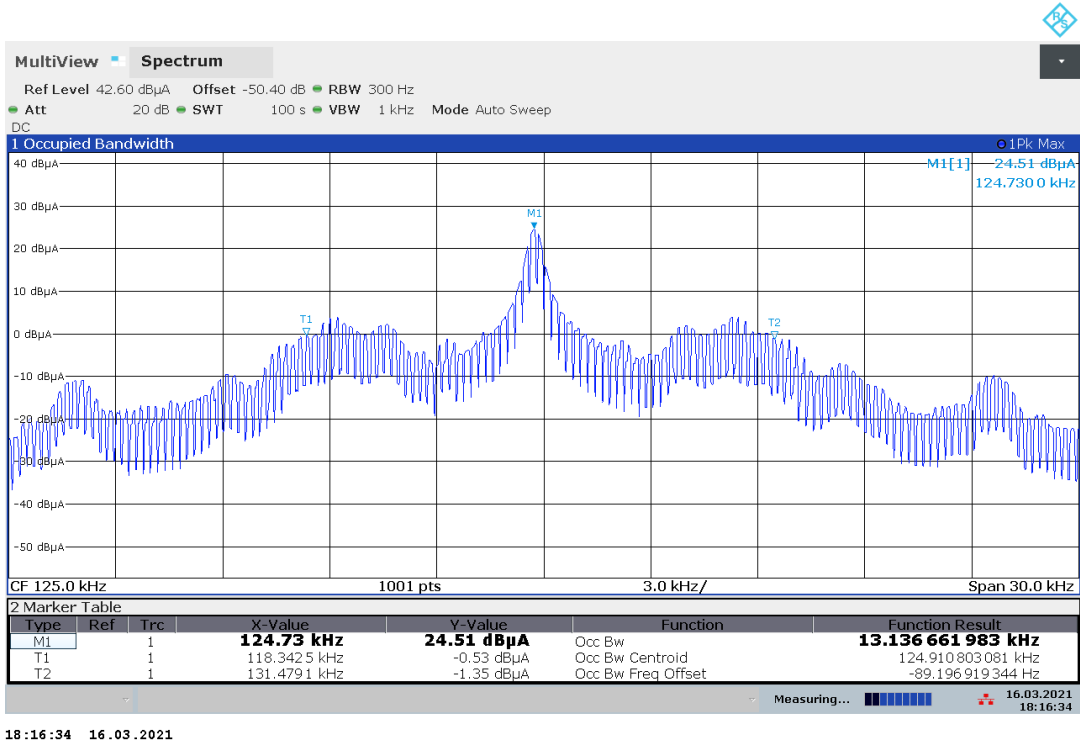

## 10 MEASUREMENT UNCERTAINTIES

Radio frequency	$\leq \pm 10$ ppm
Radiated emission	$\leq \pm 6$ dB
Temperature	$\leq \pm 1$ °C
Humidity	$\leq \pm 5$ %
DC and low frequency voltages	$\leq \pm 3$ %

The indicated expanded measurement uncertainty corresponds to the standard measurement uncertainty for the measurement results multiplied by the coverage factor  $k = 2$ . It was determined in accordance with EA-4/02 M:2013. The true value is located in the corresponding interval with a probability of 95 %.

---

**End of Test Report**

---