

---

EUT: MLx Handle 13.56 MHz FCC ID: QLXHFHANDLE FCC Title 47 CFR Part 15 Date of issue: 2016-11-15

**Annex acc. to FCC Title 47 CFR Part 15  
relating to  
TeraTron GmbH  
MLx Handle 13.56 MHz**

# **Annex no. 5 User Manual Functional Description**

**Title 47 - Telecommunication  
Part 15 - Radio Frequency Devices  
Subpart C – Intentional Radiators  
ANSI C63.4-2014  
ANSI C63.10-2013**



Deutsche  
Akkreditierungsstelle  
D-PL-12053-01-00

---

**EUT: MLx Handle 13.56 MHz FCC ID: QLXHFHANDLE FCC Title 47 CFR Part 15 Date of issue: 2016-11-15**

**User Manual / Functional Description of the test equipment (EUT)**

Document no.	MLx LF Handle 125kHz / MLx HF Handle 13,56MHz User Manual	
Project	MLx Handle 125kHz / MLx Handle 13,56MHz	
Document for	FCC and IC	Creation date: 11.11.2016

## Functional Description of the MLx 125kHz Handle and MLx 13,56MHz Handle

The MLx 125kHz (LF) and MLx (HF) 13,56MHz Handles offer a general RFID reader functionality, powered by an external 5V DC voltage source. The MLX Handles are used in combination with the MLx Readers (e.g. MLx2000, MLx3000 and MLx5000), that control the Handles RFID transponder reading functionality via a 2-wire data bus. The Handles RFID functionality includes reading of several types of 125kHz (e.g. HITAG) or 13,56MHz ISO transponder (e.g. ISO15693, ISO14443) types.

The  $\mu$ P of the MLx Handles is clocked by a 16MHz-Resonator. The active components are powered by 5V from an external linear LDO regulator (located on the MLx Readers). The 125kHz-Reader IC (P4097) drives the 125kHz coil antenna. The 13,56MHz Reader IC (CLRC663) drives a 13,56MHz coil antenna respectively.

When reading a valid transponder, the data is sent via the data bus. The external MLx Reader identifies and returns a signal on the data bus to unlock the actuator of the handle.

If a handle has an actuator, the MLx handle then controls the actuator and unlocks.

This actuator is usually a 12V permanent magnet motor, which unlocks the handle, so the user can get access to a door, or compartment, e.g.

In case the Handle has a Keypad, the user can enter a digit code to get access on a 12-digit keyboard located in the handle front side. However the keypad functionality is optional, it does not affect the RFID functionality. The status of the Handle is shown to the user by RGB LEDs.



All LF and HF handles share the same RFID reader functionality.

Revision	Generate	Approved	Confidentiality	Page	Document
1.0	MSC	RHE	Strictly confidential	1 of 3	MLx LF/HF Handle User Manual

Document no.	MLx LF Handle 125kHz / MLx HF Handle 13,56MHz User Manual	
Project	MLx Handle 125kHz / MLx Handle 13,56MHz	
Document for	FCC and IC	Creation date: 11.11.2016

## Functional Block Diagram

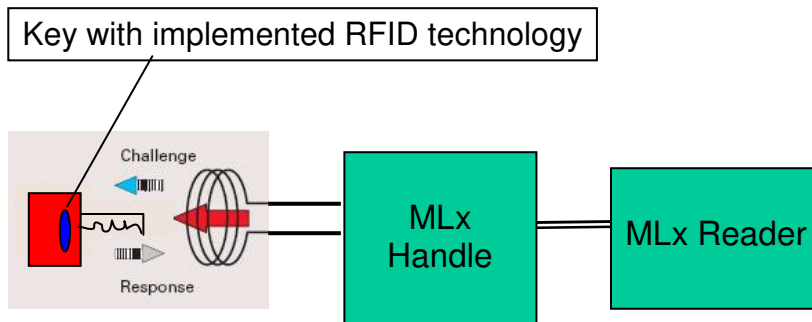

MLx Handles: 125kHz (LF) or 13,56MHz (HF) Handles  
 MLx Readers: MLx2000 or MLx3000 or MLx5000

Revision	Generate	Approved	Confidentiality	Page	Document
1.0	MSC	RHE	Strictly confidential	2 of 3	MLx LF/HF Handle User Manual

Document no.	MLx LF Handle 125kHz / MLx HF Handle 13,56MHz User Manual	
Project	MLx Handle 125kHz / MLx Handle 13,56MHz	
Document for	FCC and IC	Creation date: 11.11.2016

## Compliance Statements

### Compliance Statements FCC

The title “**CAUTION TO USERS**” or “**FCC/IC WARNING NOTE**” or relevant title and “**Changes or modifications not expressly approved by the party responsible for compliance could void the user’s authority to operate the equipment.**”

This device complies with Part 15 of the FCC Rules. Operation is subject to the following two conditions:

- (1) this device may not cause harmful interference, and
- (2) this device must accept any interference received, including interference that may cause undesired operation.

### Compliance Statements IC

This device complies with Industry Canada licence-exempt RSS standard(s). Operation is subject to the following two conditions: (1) this device may not cause interference, and (2) this device must accept any interference, including interference that may cause undesired operation of the device.

Le présent appareil est conforme aux CNR d'Industrie Canada applicables aux appareils radio exempts de licence. L'exploitation est autorisée aux deux conditions suivantes : (1) l'appareil ne doit pas produire de brouillage, et (2) l'utilisateur de l'appareil doit accepter tout brouillage radioélectrique subi, même si le brouillage est susceptible d'en compromettre le fonctionnement.

Revision	Generate	Approved	Confidentiality	Page	Document
1.0	MSC	RHE	Strictly confidential	3 of 3	MLx LF/HF Handle User Manual