



FCC TEST REPORT (15.407)

REPORT NO.: RF940125L04
MODEL NO.: VA4200
RECEIVED: Apr. 02, 2005
TESTED: Apr. 02 ~ Jul. 04, 2005
ISSUED: Jul. 04, 2005

APPLICANT: Vivato, Inc.

ADDRESS: 12610 E Mirabeau Pkwy Suite 900

ISSUED BY: Advance Data Technology Corporation

LAB ADDRESS: No. 47, 14th Ling, Chia Pau Tsuen, Lin Kou
Hsiang 244, Taipei Hsien, Taiwan, R.O.C.

TEST LOCATION: No. 19, Hwa Ya 2nd Rd., Wen Hwa Tsuen, Kwei
Shan Hsiang, Taoyuan Hsien 333, Taiwan,
R.O.C.

This test report consists of 84 pages in total. It may be duplicated completely for legal use with the approval of the applicant. It should not be reproduced except in full, without the written approval of our laboratory. The client should not use it to claim product endorsement by CNLA, A2LA or any government agencies. The test results in the report only apply to the tested sample.



0528
ILAC MRA



No. 2177-01



Table of Contents

1.	CERTIFICATION	4
2.	SUMMARY OF TEST RESULTS	5
2.1	MEASUREMENT UNCERTAINTY	5
3.	GENERAL INFORMATION.....	6
3.1	GENERAL DESCRIPTION OF EUT.....	6
3.2	DESCRIPTION OF TEST MODES.....	8
3.2.1	CONFIGURATION OF SYSTEM UNDER TEST	9
3.2.2	TEST MODE APPLICABILITY AND TESTED CHANNEL DETAIL:.....	10
3.3	GENERAL DESCRIPTION OF APPLIED STANDARDS	12
3.4	DESCRIPTION OF SUPPORT UNITS	12
4.	TEST TYPES AND RESULTS (5150 ~ 5350MHz BAND)	13
4.1	CONDUCTED EMISSION MEASUREMENT	13
4.1.1	LIMITS OF CONDUCTED EMISSION MEASUREMENT.....	13
4.1.2	TEST INSTRUMENTS.....	13
4.1.3	TEST PROCEDURES	14
4.1.4	DEVIATION FROM TEST STANDARD	14
4.1.5	TEST SETUP	15
4.1.6	EUT OPERATING CONDITIONS	15
4.1.7	TEST RESULTS	16
4.2	RADIATED EMISSION MEASUREMENT	22
4.2.1	LIMITS OF RADIATED EMISSION MEASUREMENT.....	22
4.2.2	LIMITS OF UNWANTED EMISSION OUT OF THE RESTRICTED BANDS.....	23
4.2.3	TEST INSTRUMENTS.....	24
4.2.4	TEST PROCEDURES	25
4.2.5	DEVIATION FROM TEST STANDARD	25
4.2.6	TEST SETUP	26
4.2.7	EUT OPERATING CONDITION	26
4.2.8	TEST RESULTS	27
4.3	PEAK TRANSMIT POWER MEASUREMENT	37
4.3.1	LIMITS OF PEAK TRANSMIT POWER MEASUREMENT.....	37
4.3.2	TEST INSTRUMENTS.....	37
4.3.3	TEST PROCEDURE.....	38
4.3.4	DEVIATION FROM TEST STANDARD	38
4.3.5	TEST SETUP	38
4.3.6	EUT OPERATING CONDITIONS	38
4.3.7	TEST RESULTS	39
4.4	PEAK POWER EXCURSION MEASUREMENT	49
4.4.1	LIMITS OF PEAK POWER EXCURSION MEASUREMENT.....	49
4.4.2	TEST INSTRUMENTS.....	49
4.4.3	TEST PROCEDURE.....	50
4.4.4	DEVIATION FROM TEST STANDARD	50
4.4.5	TEST SETUP	50
4.4.6	EUT OPERATING CONDITIONS	50
4.4.7	TEST RESULTS	51
4.5	PEAK POWER SPECTRAL DENSITY MEASUREMENT	57
4.5.1	LIMITS OF PEAK POWER SPECTRAL DENSITY MEASUREMENT.....	57
4.5.2	TEST INSTRUMENTS.....	57



4.5.3	TEST PROCEDURES	58
4.5.4	DEVIATION FROM TEST STANDARD	58
4.5.5	TEST SETUP	58
4.5.6	EUT OPERATING CONDITIONS	58
4.5.7	TEST RESULTS	59
4.6	FREQUENCY STABILITY	65
4.6.1	LIMITS OF FREQUENCY STABILITY MEASUREMENT	65
4.6.2	TEST INSTRUMENTS.....	65
4.6.3	TEST PROCEDURE.....	65
4.6.4	DEVIATION FROM TEST STANDARD	65
4.6.5	TEST SETUP	66
4.6.6	EUT OPERATING CONDITION	66
4.6.7	TEST RESULTS	67
4.7	BAND EDGES MEASUREMENT	68
4.7.1	TEST INSTRUMENTS.....	68
4.7.2	TEST PROCEDURE.....	68
4.7.3	EUT OPERATING CONDITION	68
4.7.4	TEST RESULTS	68
4.8	ANTENNA REQUIREMENT	77
4.8.1	STANDARD APPLICABLE	77
4.8.2	ANTENNA CONNECTED CONSTRUCTION.....	77
5.	PHOTOGRAPHS OF THE TEST CONFIGURATION.....	78
6.	INFORMATION ON THE TESTING LABORATORIES	84



1. CERTIFICATION

PRODUCT: VA4200 Wi-Fi AP/Bridge
BRAND NAME: VIVATO
MODEL NO.: VA4200
APPLICANT: Vivato, Inc.
TEST SAMPLE: ENGINEERING SAMPLE
TESTED: Apr. 02 ~ Jul. 04, 2005
STANDARDS: FCC Part 15, Subpart E (Section 15.407)
ANSI C63.4-2003

The above equipment has been tested by **Advance Data Technology Corporation**, and found compliance with the requirement of the above standards. The test record, data evaluation & Equipment Under Test (EUT) configurations represented herein are true and accurate accounts of the measurements of the sample's EMC characteristics under the conditions specified in this report.

PREPARED BY : Andrea Hsia , **DATE:** Jul. 04, 2005
(Andrea Hsia)

TECHNICAL
ACCEPTANCE : Gary Chang , **DATE:** Jul. 04, 2005
Responsible for RF (Gary Chang)

APPROVED BY : Cody Chang , **DATE:** Jul. 04, 2005
(Cody Chang, Deputy Manager)

2. SUMMARY OF TEST RESULTS

The EUT has been tested according to the following specifications:

APPLIED STANDARD: FCC Part 15, Subpart E (Section 15.407)			
Standard Section	Test Type	Result	Remark
15.407(b)(5)	AC Power Conducted Emission	PASS	Meet the requirement of limit. Minimum passing margin is -10.21dB at 0.177MHz
15.407(b/1/2/3) (b)(5)	Electric Field Strength Spurious Emissions, 30MHz ~ 40000MHz	PASS	Meet the requirement of limit. Minimum passing margin is -1.79dB at 934.10MHz
15.407(a/1/2/3)	Peak Transmit Power	PASS	Meet the requirement of limit.
15.407(a)(6)	Peak Power Excursion	PASS	Meet the requirement of limit.
15.407(a/1/2/3)	Peak Power Spectral Density	PASS	Meet the requirement of limit.
15.407(g)	Frequency Stability	PASS	Meet the requirement of limit.

2.1 MEASUREMENT UNCERTAINTY

Where relevant, the following measurement uncertainty levels have been estimated for tests performed on the EUT as specified in CISPR 16-4:

Measurement	Frequency	Uncertainty
Conducted emissions	9kHz~30MHz	2.44 dB
Radiated emissions	30MHz ~ 200MHz	3.73 dB
	200MHz ~1000MHz	3.74 dB
	1GHz ~ 18GHz	2.20 dB
	18GHz ~ 40GHz	1.88 dB



3. GENERAL INFORMATION

3.1 GENERAL DESCRIPTION OF EUT

EUT	VA4200 Wi-Fi AP/Bridge
MODEL NO.	VA4200
POWER SUPPLY	12Vdc from AC Adapter 48Vdc from POE
MODULATION TYPE	CCK, DQPSK, DBPSK for DSSS 64QAM, 16QAM, QPSK, BPSK for OFDM
MODULATION TECHNOLOGY	DSSS, OFDM
TRANSFER RATE	802.11b: 11/5.5/2/1Mbps 802.11g: 54/48/36/24/18/12/9/6Mbps 802.11a: 54/48/36/24/18/12/9/6Mbps (Turbo mode: up to 108Mbps *see Note 4)
FREQUENCY RANGE	802.11b & 802.11g: 2.412 ~ 2.462GHz 802.11a: 5.150 ~ 5.350GHz and 5.725 ~ 5.850GHz
NUMBER OF CHANNEL	802.11b & 802.11g: 11 802.11a: 13 for Normal mode / 3 for Turbo mode
CHANNEL SPACING	802.11b & 802.11g: 5MHz 802.11a: 20MHz for Normal mode / 40MHz for Turbo mode
OUTPUT POWER	101.158mW for 802.11b 57.280mW for 802.11g 63.973mW for 5.150 ~ 5.350GHz 70.958mW for 5.725 ~ 5.850GHz
ANTENNA TYPE	Dipole antenna with 2.0dBi gain
DATA CABLE	NA
I/O PORTS	RJ45
ASSOCIATED DEVICES	NA

NOTE:

- The EUT were operated with following power adapters:

BRAND:	JET
MODEL:	RHE-120150-7
INPUT:	120-240Vac, 50/60Hz, 0.7A
OUTPUT:	12Vdc, 1.5A
POWER LINE:	DC 1.8m non-shielded cable without core AC 1.6m non-shielded cable without core
BRAND:	LEI (LEADER ELECTRONICS INC.)
MODEL:	NU20-5120200-I2
INPUT:	100-240Vac, 50/60Hz, 1A
OUTPUT:	12Vdc, 2.0A
POWER LINE:	DC 1.8m non-shielded cable with one core AC 1.6m non-shielded cable without core



2. The EUT was operated with following POE:

BRAND:	Gemtek Systems E-120 POE HUB
MODEL:	PWI30RB4800N52
INPUT:	100-250Vac, 50/60Hz, 500mA
OUTPUT:	48Vdc, 350mA
POWER LINE:	AC 1.6m non-shielded cable without core

3. The EUT operates in both the 5GHz and 2.4GHz Bands and compatibility with 802.11a and 802.11b, 802.11g technology.
4. This EUT is capable of providing data rates of up to 108 Mbps in Turbo mode depending upon reception quality and the turbo mode only use in the frequency range 5150MHz ~ 5350MHz.
5. The above EUT information was declared by the manufacturer and for more detailed features description, please refer to the manufacturer's specifications or User's Manual.

3.2 DESCRIPTION OF TEST MODES

Operated in 5150 ~ 5250MHz, 5250MHz ~ 5350MHz bands:

Eight channels are provided to this EUT for normal mode.

Channel	Frequency
1	5180 MHz
2	5200 MHz
3	5220 MHz
4	5240 MHz
5	5260 MHz
6	5280 MHz
7	5300 MHz
8	5320 MHz

Three channels are provided to this EUT for turbo mode.

Channel	Frequency
1	5210 MHz
2	5250 MHz
3	5290 MHz

3.2.1 CONFIGURATION OF SYSTEM UNDER TEST

Test Mode 1 & 2

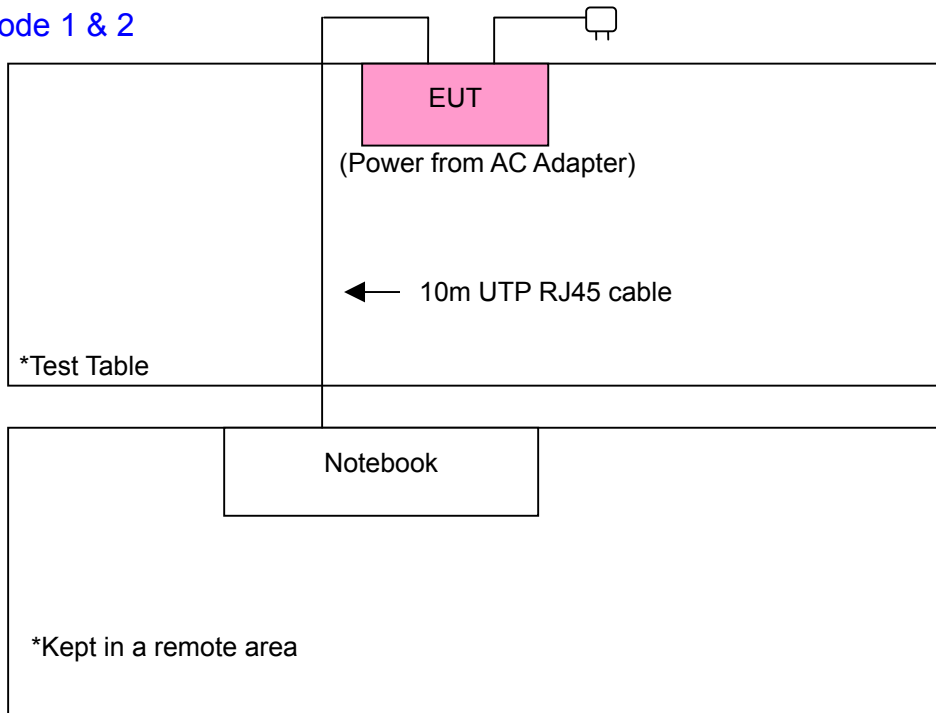

Test Mode 3

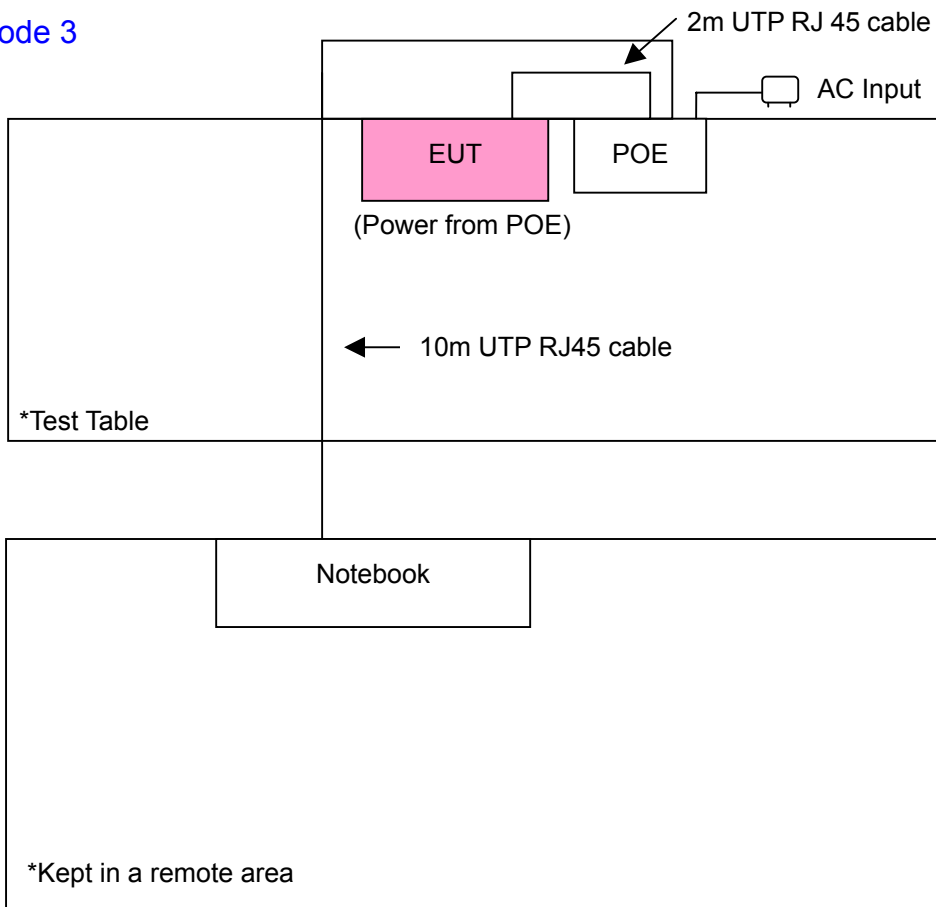



3.2.2 TEST MODE APPLICABILITY AND TESTED CHANNEL DETAIL:

EUT configure mode	Applicable to				Description
	PLC	RE<1G	RE≥1G	APCM	
1	v	v	Note1	Note 2	Power from AC adapter (RHE-120150-7)
2	v	v	Note1	Note 2	Power from AC adapter (NU20-5120200-12)
3	v	v	Note1	Note 2	Power from POE

Where PLC: Power Line Conducted Emission RE<1G RE: Radiated Emission below 1GHz
 RE≥1G: Radiated Emission above 1GHz APCM: Antenna Port Conducted Measurement
 Note 1: No effect on Radiated Emission above 1GHz.
 Note 2: No effect on Conducted RF measurement.

Power Line Conducted Emission Test:

- Pre-Scan has been conducted to determine the worst-case mode from all possible combinations between available modulations, data rates and antenna ports (if EUT with antenna diversity architecture).
- Following channel(s) was (were) selected for the final test as listed below.

EUT configure mode	Mode	Available Channel	Tested Channel	Modulation Technology	Modulation Type	Data Rate (Mbps)
1	802.11a	1 to 8	1	OFDM	BPSK	6
2	802.11a	1 to 8	1	OFDM	BPSK	6
3	802.11a	1 to 8	1	OFDM	BPSK	6

Radiated Emission Test (Below 1 GHz):

- Pre-Scan has been conducted to determine the worst-case mode from all possible combinations between available modulations, data rates and antenna ports (if EUT with antenna diversity architecture).
- Following channel(s) was (were) selected for the final test as listed below.

EUT configure mode	Mode	Available Channel	Tested Channel	Modulation Technology	Modulation Type	Data Rate (Mbps)
1	802.11a	1 to 8	1	OFDM	BPSK	6
2	802.11a	1 to 8	1	OFDM	BPSK	6
3	802.11a	1 to 8	1	OFDM	BPSK	6

Radiated Emission Test (Above 1 GHz):

- Pre-Scan has been conducted to determine the worst-case mode from all possible combinations between available modulations, data rates and antenna ports (if EUT with antenna diversity architecture).
- Following channel(s) was (were) selected for the final test as listed below.

EUT configure mode	Mode	Available Channel	Tested Channel	Modulation Technology	Modulation Type	Data Rate (Mbps)
3	802.11a	1 to 8	1, 4, 5, 8	OFDM	BPSK	6
3	802.11a turbo	1 to 3	1, 2, 3	OFDM	BPSK	12



Bandedge Measurement:

- Pre-Scan has been conducted to determine the worst-case mode from all possible combinations between available modulations, data rates and antenna ports (if EUT with antenna diversity architecture).
- Following channel(s) was (were) selected for the final test as listed below.

Mode	Available Channel	Tested Channel	Modulation Technology	Modulation Type	Data Rate (Mbps)
802.11a	1 to 8	1, 8	OFDM	BPSK	6
802.11a turbo	1 to 3	1, 3	OFDM	BPSK	12

Antenna Port Conducted Measurement:

- Pre-Scan has been conducted to determine the worst-case mode from all possible combinations between available modulations, data rates and antenna ports (if EUT with antenna diversity architecture).
- Following channel(s) was (were) selected for the final test as listed below.

Mode	Available Channel	Tested Channel	Modulation Technology	Modulation Type	Data Rate (Mbps)
802.11a	1 to 8	1, 4, 5, 8	OFDM	BPSK	6
802.11a turbo	1 to 3	1, 2, 3	OFDM	BPSK	12



3.3 GENERAL DESCRIPTION OF APPLIED STANDARDS

The EUT is a VA4200 Wi-Fi AP/Bridge. According to the specifications of the manufacturer, it must comply with the requirements of the following standards:

FCC Part 15, Subpart E (15.407)

ANSI C63.4-2003

All test items have been performed and recorded as per the above standards.

NOTE: The EUT is also considered as a kind of computer peripheral, because the connection to computer is necessary for typical use. It has been verified to comply with the requirements of FCC Part 15, Subpart B, Class B (DoC). The test report has been issued separately.

3.4 DESCRIPTION OF SUPPORT UNITS

The EUT has been tested as an independent unit together with other necessary accessories or support units. The following support units or accessories were used to form a representative test configuration during the tests.

NO.	PRODUCT	BRAND	MODEL NO.	SERIAL NO.	FCC ID
1	NOTEBOOK COMPUTER	DELL	PP05L	12130898320	E2K24CLNS

NO.	SIGNAL CABLE DESCRIPTION OF THE ABOVE SUPPORT UNITS
1	NA

NOTE: All power cords of the above support units are non shielded (1.8m).



4. TEST TYPES AND RESULTS (5150 ~ 5350MHz Band)

4.1 CONDUCTED EMISSION MEASUREMENT

4.1.1 LIMITS OF CONDUCTED EMISSION MEASUREMENT

FREQUENCY OF EMISSION (MHz)	CONDUCTED LIMIT (dB μ V)	
	Quasi-peak	Average
0.15-0.5	66 to 56	56 to 46
0.5-5	56	46
5-30	60	50

- NOTE:**
1. The lower limit shall apply at the transition frequencies.
 2. The limit decreases in line with the logarithm of the frequency in the range of 0.15 to 0.50 MHz.
 3. All emanations from a class A/B digital device or system, including any network of conductors and apparatus connected thereto, shall not exceed the level of field strengths specified above.

4.1.2 TEST INSTRUMENTS

DESCRIPTION & MANUFACTURER	MODEL NO.	SERIAL NO.	CALIBRATED UNTIL
Test Receiver ROHDE & SCHWARZ	ESCS30	100288	Nov. 06, 2005
RF signal cable Woken	5D-FB	Cable-HyC02-01	Jan. 09, 2006
LISN ROHDE & SCHWARZ	ESH2-Z5	100100	Jan. 20, 2006
LISN ROHDE & SCHWARZ	ESH3-Z5	100311	Jan. 20, 2006
Software ADT	ADT_Cond_V3	NA	NA

- NOTE:**
1. The calibration interval of the above test instruments is 12 months and the calibrations are traceable to NML/ROC and NIST/USA.
 2. The test was performed in HwaYa Shielded Room 3.
 3. The VCCI Site Registration No. is C-2047.



4.1.3 TEST PROCEDURES

- a. The EUT was placed 0.4 meters from the conducting wall of the shielded room with EUT being connected to the power mains through a line impedance stabilization network (LISN). Other support units were connected to the power mains through another LISN. The two LISNs provide 50 ohm/ 50uH of coupling impedance for the measuring instrument.
- b. Both lines of the power mains connected to the EUT were checked for maximum conducted interference.
- c. The frequency range from 150kHz to 30MHz was searched. Emission levels under (Limit - 20dB) was not recorded.

4.1.4 DEVIATION FROM TEST STANDARD

No deviation

4.1.5 TEST SETUP

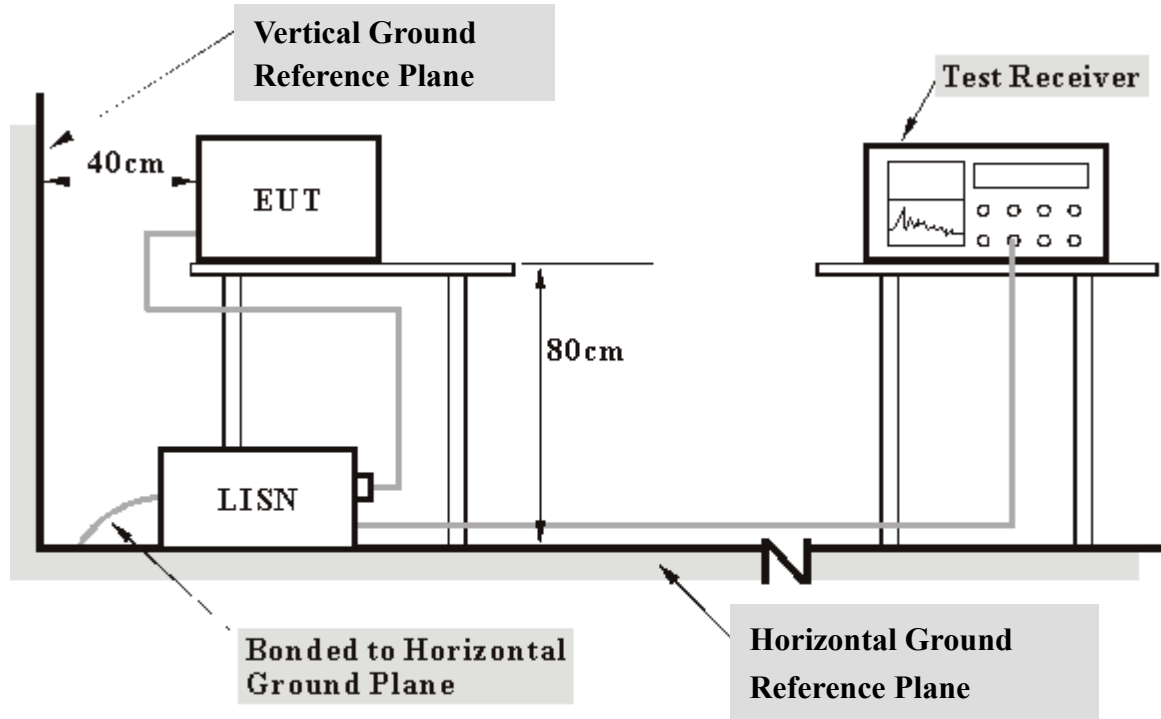

- Note:**
1. Support units were connected to second LISN.
 2. Both of LISNs (AMN) 80 cm from EUT and at the least 80 cm from other units and other metal planes support units.

For the actual test configuration, please refer to the related item – Photographs of the Test Configuration.

4.1.6 EUT OPERATING CONDITIONS

- a. Placed the EUT on the testing table.
- b. Prepared another notebook system to act as a communication partner and placed it outside of testing area.
- c. The communication partner run a test program (provided by manufacturer) to enable EUT under transmission/receiving condition continuously at specific channel frequency via an RJ45 cable.
- d. The communication partner sent data to EUT by command "PING".



4.1.7 TEST RESULTS

Conducted Worst-Case Data (Power from AC Adapter: RHE-120150-7)

EUT	VA4200 Wi-Fi AP/Bridge	MEASUREMENT DETAIL	
MODEL	VA4200	PHASE	Line 1
CHANNEL	Channel 1	6dB BANDWIDTH	9 kHz
MODULATION TYPE	BPSK	ENVIRONMENTAL CONDITIONS	23deg. C, 65%RH, 991hPa
TRANSFER RATE	6Mbps	INPUT POWER (SYSTEM)	120Vac, 60 Hz
TEST MODE	1	TESTED BY	Gary Chang

No	Freq. [MHz]	Corr. Factor (dB)	Reading Value [dB (uV)]		Emission Level [dB (uV)]		Limit [dB (uV)]		Margin (dB)	
			Q.P.	AV.	Q.P.	AV.	Q.P.	AV.	Q.P.	AV.
			1	0.177	0.10	54.10	-	54.20	-	64.61
2	0.236	0.10	47.41	-	47.51	-	62.24	52.24	-14.73	-
3	0.295	0.10	42.98	-	43.08	-	60.40	50.40	-17.32	-
4	0.529	0.12	41.38	-	41.50	-	56.00	46.00	-14.50	-
5	13.418	0.37	37.69	-	38.06	-	60.00	50.00	-21.94	-
6	18.914	0.71	38.84	-	39.55	-	60.00	50.00	-20.45	-

- REMARKS:**
1. Q.P. and AV. are abbreviations of quasi-peak and average individually.
 2. "-": The Quasi-peak reading value also meets average limit and measurement with the average detector is unnecessary.
 3. The emission levels of other frequencies were very low against the limit.
 4. Margin value = Emission level - Limit value
 5. Correction factor = Insertion loss + Cable loss
 6. Emission Level = Correction Factor + Reading Value.

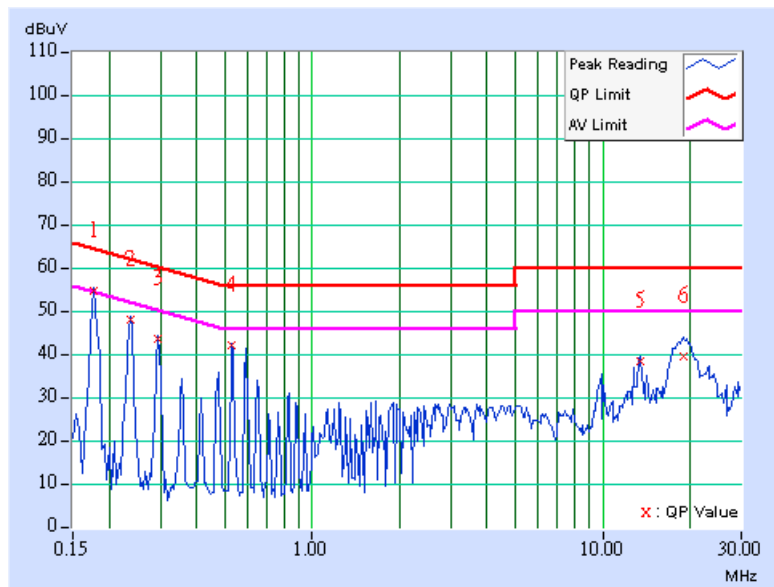



EUT	VA4200 Wi-Fi AP/Bridge	MEASUREMENT DETAIL	
MODEL	VA4200	PHASE	Line 2
CHANNEL	Channel 1	6dB BANDWIDTH	9 kHz
MODULATION TYPE	BPSK	ENVIRONMENTAL CONDITIONS	23deg. C, 65%RH, 991hPa
TRANSFER RATE	6Mbps	INPUT POWER (SYSTEM)	120Vac, 60 Hz
TEST MODE	1	TESTED BY	Gary Chang

No	Freq. [MHz]	Corr. Factor (dB)	Reading Value [dB (uV)]		Emission Level [dB (uV)]		Limit [dB (uV)]		Margin (dB)	
			Q.P.	AV.	Q.P.	AV.	Q.P.	AV.	Q.P.	AV.
			1	0.177	0.10	54.30	-	54.40	-	64.61
2	0.236	0.10	48.16	-	48.26	-	62.24	52.24	-13.98	-
3	0.295	0.10	44.06	-	44.16	-	60.40	50.40	-16.24	-
4	0.529	0.12	42.47	-	42.59	-	56.00	46.00	-13.41	-
5	13.359	0.47	37.89	-	38.36	-	60.00	50.00	-21.64	-
6	19.707	0.78	39.04	-	39.82	-	60.00	50.00	-20.18	-

- REMARKS:**
1. Q.P. and AV. are abbreviations of quasi-peak and average individually.
 2. "-": The Quasi-peak reading value also meets average limit and measurement with the average detector is unnecessary.
 3. The emission levels of other frequencies were very low against the limit.
 4. Margin value = Emission level - Limit value
 5. Correction factor = Insertion loss + Cable loss
 6. Emission Level = Correction Factor + Reading Value.

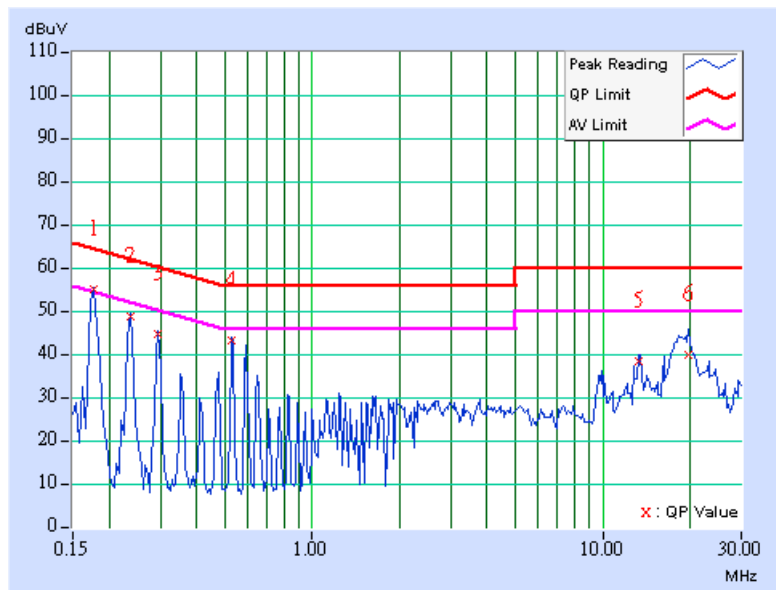



Conducted Worst-Case Data (Power from AC Adapter: NU20-5120200-I2)

EUT	VA4200 Wi-Fi AP/Bridge	MEASUREMENT DETAIL	
MODEL	VA4200	PHASE	Line 1
CHANNEL	Channel 1	6dB BANDWIDTH	9 kHz
MODULATION TYPE	BPSK	ENVIRONMENTAL CONDITIONS	25deg. C, 66%RH, 991hPa
TRANSFER RATE	6Mbps	INPUT POWER (SYSTEM)	120Vac, 60 Hz
TEST MODE	2	TESTED BY	Gary Chang

No	Freq. [MHz]	Corr. Factor (dB)	Reading Value		Emission Level		Limit		Margin	
			[dB (uV)]		[dB (uV)]		[dB (uV)]		(dB)	
			Q.P.	AV.	Q.P.	AV.	Q.P.	AV.	Q.P.	AV.
1	0.197	0.11	37.50	-	37.61	-	63.74	53.74	-26.13	-
2	0.263	0.11	32.44	-	32.55	-	61.33	51.33	-28.78	-
3	0.392	0.11	27.36	-	27.47	-	58.02	48.02	-30.55	-
4	2.633	0.30	30.07	-	30.37	-	56.00	46.00	-25.63	-
5	4.934	0.41	27.62	-	28.03	-	56.00	46.00	-27.97	-
6	18.094	0.85	32.43	-	33.28	-	60.00	50.00	-26.72	-

- REMARKS:**
1. Q.P. and AV. are abbreviations of quasi-peak and average individually.
 2. "-": The Quasi-peak reading value also meets average limit and measurement with the average detector is unnecessary.
 3. The emission levels of other frequencies were very low against the limit.
 4. Margin value = Emission level - Limit value
 5. Correction factor = Insertion loss + Cable loss
 6. Emission Level = Correction Factor + Reading Value.

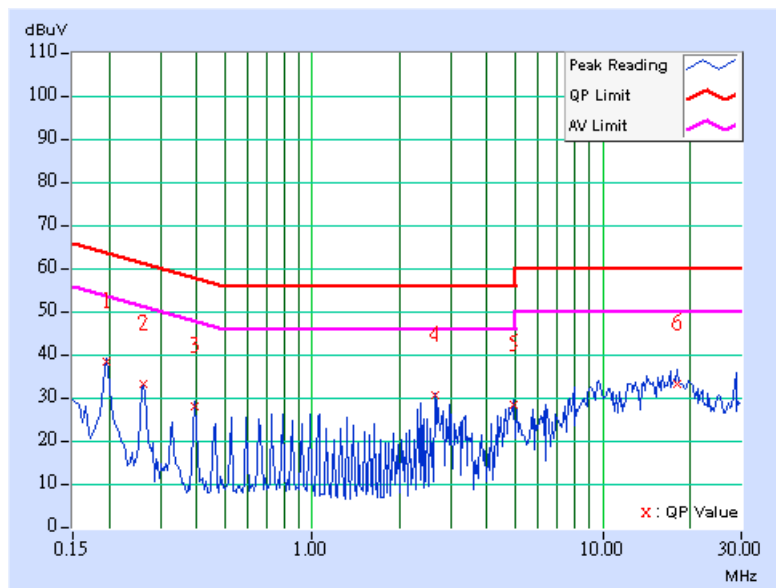



EUT	VA4200 Wi-Fi AP/Bridge	MEASUREMENT DETAIL	
MODEL	VA4200	PHASE	Line 2
CHANNEL	Channel 1	6dB BANDWIDTH	9 kHz
MODULATION TYPE	BPSK	ENVIRONMENTAL CONDITIONS	25deg. C, 66%RH, 991hPa
TRANSFER RATE	6Mbps	INPUT POWER (SYSTEM)	120Vac, 60 Hz
TEST MODE	2	TESTED BY	Gary Chang

No	Freq. [MHz]	Corr. Factor (dB)	Reading Value [dB (uV)]		Emission Level [dB (uV)]		Limit [dB (uV)]		Margin (dB)	
			Q.P.	AV.	Q.P.	AV.	Q.P.	AV.	Q.P.	AV.
			1	0.197	0.11	36.95	-	37.06	-	63.74
2	0.259	0.11	27.27	-	27.38	-	61.45	51.45	-34.07	-
3	0.791	0.19	27.06	-	27.25	-	56.00	46.00	-28.75	-
4	2.762	0.31	30.36	-	30.67	-	56.00	46.00	-25.33	-
5	9.211	0.43	31.29	-	31.72	-	60.00	50.00	-28.28	-
6	14.672	0.45	32.70	-	33.15	-	60.00	50.00	-26.85	-

- REMARKS:**
1. Q.P. and AV. are abbreviations of quasi-peak and average individually.
 2. "-": The Quasi-peak reading value also meets average limit and measurement with the average detector is unnecessary.
 3. The emission levels of other frequencies were very low against the limit.
 4. Margin value = Emission level - Limit value
 5. Correction factor = Insertion loss + Cable loss
 6. Emission Level = Correction Factor + Reading Value.

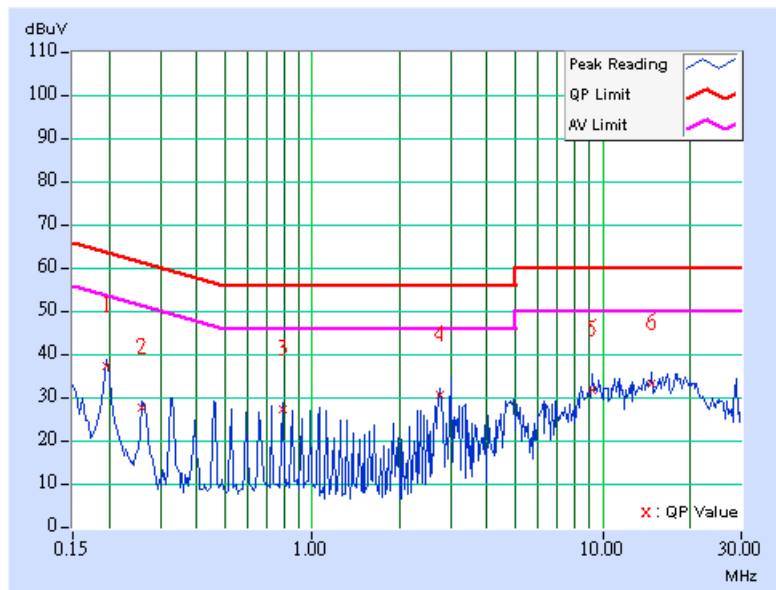



Conducted Worst-Case Data (Power from POE)

EUT	VA4200 Wi-Fi AP/Bridge	MEASUREMENT DETAIL	
MODEL	VA4200	PHASE	Line 1
CHANNEL	Channel 1	6dB BANDWIDTH	9 kHz
MODULATION TYPE	BPSK	ENVIRONMENTAL CONDITIONS	23deg. C, 65%RH, 991hPa
TRANSFER RATE	6Mbps	INPUT POWER (SYSTEM)	120Vac, 60 Hz
TEST MODE	3	TESTED BY	Gary Chang

No	Freq. [MHz]	Corr. Factor (dB)	Reading Value		Emission Level		Limit		Margin	
			[dB (uV)]		[dB (uV)]		[dB (uV)]		(dB)	
			Q.P.	AV.	Q.P.	AV.	Q.P.	AV.	Q.P.	AV.
1	0.205	0.10	38.24	-	38.34	-	63.42	53.42	-25.08	-
2	0.470	0.11	36.60	-	36.71	-	56.51	46.51	-19.80	-
3	0.943	0.19	34.53	-	34.72	-	56.00	46.00	-21.28	-
4	1.953	0.20	35.49	-	35.69	-	56.00	46.00	-20.31	-
5	19.301	0.74	41.38	-	42.12	-	60.00	50.00	-17.88	-
6	28.684	1.54	44.05	-	45.59	-	60.00	50.00	-14.41	-

- REMARKS:**
1. Q.P. and AV. are abbreviations of quasi-peak and average individually.
 2. "-": The Quasi-peak reading value also meets average limit and measurement with the average detector is unnecessary.
 3. The emission levels of other frequencies were very low against the limit.
 4. Margin value = Emission level - Limit value
 5. Correction factor = Insertion loss + Cable loss
 6. Emission Level = Correction Factor + Reading Value.

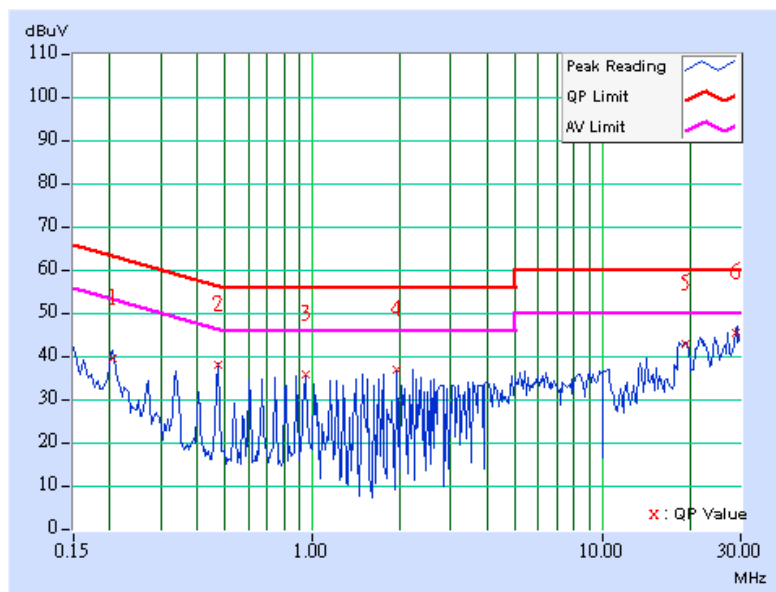



EUT	VA4200 Wi-Fi AP/Bridge	MEASUREMENT DETAIL	
MODEL	VA4200	PHASE	Line 2
CHANNEL	Channel 1	6dB BANDWIDTH	9 kHz
MODULATION TYPE	BPSK	ENVIRONMENTAL CONDITIONS	23deg. C, 65%RH, 991hPa
TRANSFER RATE	6Mbps	INPUT POWER (SYSTEM)	120Vac, 60 Hz
TEST MODE	3	TESTED BY	Gary Chang

No	Freq. [MHz]	Corr. Factor (dB)	Reading Value [dB (uV)]		Emission Level [dB (uV)]		Limit [dB (uV)]		Margin (dB)	
			Q.P.	AV.	Q.P.	AV.	Q.P.	AV.	Q.P.	AV.
			1	0.201	0.10	39.43	-	39.53	-	63.58
2	0.470	0.11	36.02	-	36.13	-	56.51	46.51	-20.38	-
3	2.023	0.20	34.82	-	35.02	-	56.00	46.00	-20.98	-
4	5.328	0.24	34.31	-	34.55	-	60.00	50.00	-25.45	-
5	19.301	0.76	41.17	-	41.93	-	60.00	50.00	-18.07	-
6	29.234	1.17	44.45	-	45.62	-	60.00	50.00	-14.38	-

- REMARKS:**
1. Q.P. and AV. are abbreviations of quasi-peak and average individually.
 2. "-": The Quasi-peak reading value also meets average limit and measurement with the average detector is unnecessary.
 3. The emission levels of other frequencies were very low against the limit.
 4. Margin value = Emission level - Limit value
 5. Correction factor = Insertion loss + Cable loss
 6. Emission Level = Correction Factor + Reading Value.

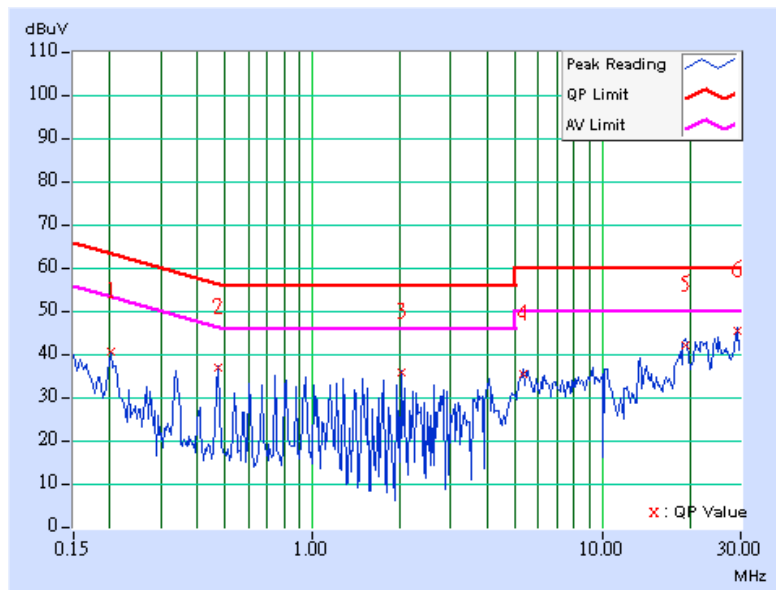



4.2 RADIATED EMISSION MEASUREMENT

4.2.1 LIMITS OF RADIATED EMISSION MEASUREMENT

Emissions radiated outside of the specified bands, shall be according to the general radiated limits in 15.209 as following:

Frequencies (MHz)	Field strength (microvolts/meter)	Measurement distance (meters)
0.009-0.490	2400/F(kHz)	300
0.490-1.705	24000/F(kHz)	30
1.705-30.0	30	30
30-88	100	3
88-216	150	3
216-960	200	3
Above 960	500	3

NOTE:

1. The lower limit shall apply at the transition frequencies.
2. Emission level (dBuV/m) = 20 log Emission level (uV/m).
3. As shown in 15.35(b), for frequencies above 1000MHz, the field strength limits are based on average detector, however, the peak field strength of any emission shall not exceed the maximum permitted average limits, specified above by more than 20dB under any condition of modulation.



4.2.2 LIMITS OF UNWANTED EMISSION OUT OF THE RESTRICTED BANDS

Frequencies (MHz)	EIRP Limit (dBm)	Equivalent Field Strength at 3m (dB μ V/m) *note 3
5150~5250	-27	68.3
5250~5350	-27	68.3
5725~5825	-27 *note 1	68.3
	-17 *note 2	78.3

NOTE:

1. For frequencies 10MHz or greater above or below the band edge.
2. All emissions within the frequency range from the band edge to 10MHz above or below the band edge.
3. The following formula is used to convert the equipment isotropic radiated power (eirp) to field strength

$$E = \frac{1000000\sqrt{30P}}{3} \quad \mu\text{V/m, where P is the eirp (Watts)}$$



4.2.3 TEST INSTRUMENTS

DESCRIPTION & MANUFACTURER	MODEL NO.	SERIAL NO.	CALIBRATED UNTIL
Test Receiver ROHDE & SCHWARZ	ESIB7	100188	Dec. 19, 2005
Spectrum Analyzer ROHDE & SCHWARZ	FSP40	100039	Nov. 21, 2005
BILOG Antenna SCHWARZBECK	VULB9168	9168-157	Jan. 22, 2006
HORN Antenna SCHWARZBECK	BBHA 9120 D	9120D-407	Jan. 16, 2006
HORN Antenna SCHWARZBECK	BBHA 9170	BBHA 9170241	Feb. 23, 2006
Preamplifier Agilent	8449B	3008A01961	Nov. 09, 2005
Preamplifier Agilent	8447D	2944A10629	Nov. 09, 2005
RF signal cable HUBER+SUHNER	SUCOFLEX 104	218182/4	Feb. 17, 2006
RF signal cable HUBER+SUHNER	SUCOFLEX 104	218194/4	Feb. 17, 2006
Software ADT.	ADT_Radiated_V5.14	NA	NA
Antenna Tower ADT.	AT100	AT93021702	NA
Turn Table ADT.	TT100.	TT93021702	NA
Controller ADT.	SC100.	SC93021702	NA

- NOTE:**
1. The calibration interval of the above test instruments is 12 months and the calibrations are traceable to NML/ROC and NIST/USA.
 2. The test was performed in HwaYa Chamber 1.
 3. The horn antenna and HP preamplifier (model: 8449B) are used only for the measurement of emission frequency above 1GHz if tested.
 4. The IC Site Registration No. is IC4924-2.



4.2.4 TEST PROCEDURES

- a. The EUT was placed on the top of a rotating table 0.8 meters above the ground at a 3 meter semi-anechoic chamber. The table was rotated 360 degrees to determine the position of the highest radiation.
- b. The EUT was set 3 meters away from the interference-receiving antenna, which was mounted on the top of a variable-height antenna tower.
- c. The antenna is a broadband antenna, and its height is varied from one meter to four meters above the ground to determine the maximum value of the field strength. Both horizontal and vertical polarizations of the antenna are set to make the measurement.
- d. For each suspected emission, the EUT was arranged to its worst case and then the antenna was tuned to heights from 1 meter to 4 meters and the rotatable table was turned from 0 degrees to 360 degrees to find the maximum reading.
- e. The test-receiver system was set to Peak Detect Function and Specified Bandwidth with Maximum Hold Mode.
- f. If the emission level of the EUT in peak mode was lower than the limit specified, then testing could be stopped and the peak values of the EUT would be reported. Otherwise the emissions would be re-tested one by one using peak, quasi-peak or average method as specified and then reported in a data sheet.

NOTE:

1. The resolution bandwidth and video bandwidth of test receiver/spectrum analyzer is 120kHz for Peak detection (PK) and Quasi-peak detection (QP) at frequency below 1GHz.
2. The resolution bandwidth and video bandwidth of test receiver/spectrum analyzer is 1 MHz for Peak detection at frequency above 1GHz.
3. The resolution bandwidth of test receiver/spectrum analyzer is 1 MHz and the video bandwidth is 10 Hz for Average detection (AV) at frequency above 1GHz.

4.2.5 DEVIATION FROM TEST STANDARD

No deviation

4.2.6 TEST SETUP

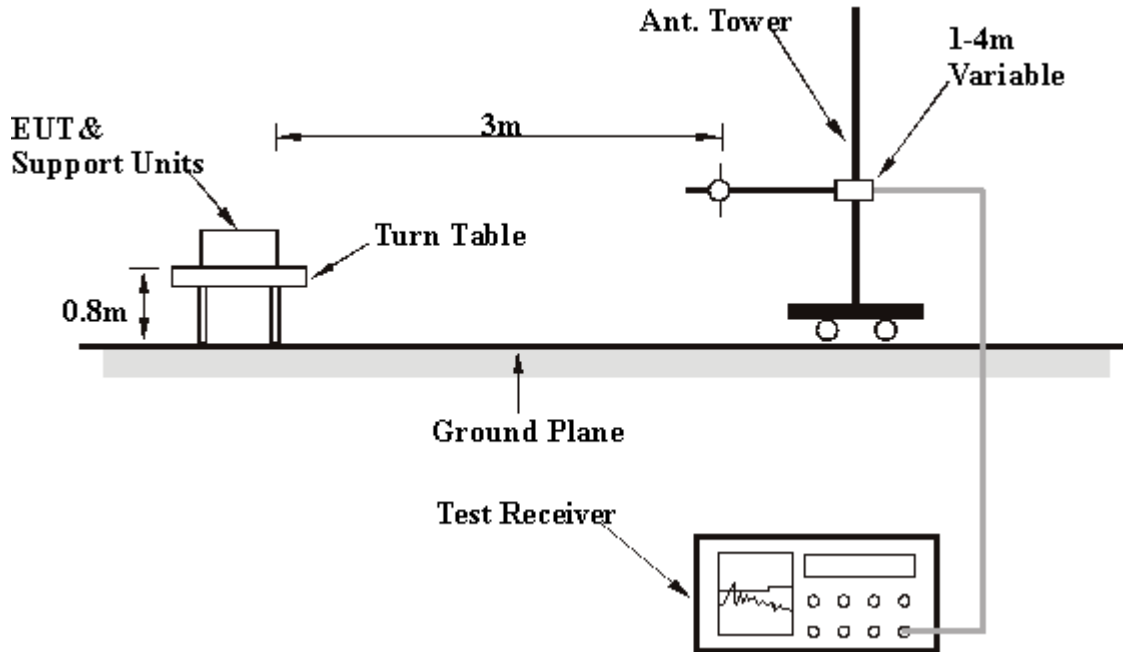

For the actual test configuration, please refer to the related item – Photographs of the Test Configuration.

4.2.7 EUT OPERATING CONDITION

Same as 4.1.6

4.2.8 TEST RESULTS

Below 1GHz Worst-Case Data (Power from AC Adapter: RHE-120150-7)

EUT	VA4200 Wi-Fi AP/Bridge	MEASUREMENT DETAIL	
MODEL	VA4200	FREQUENCY RANGE	Below 1000MHz
CHANNEL	Channel 1	DETECTOR FUNCTION	Quasi-Peak
MODULATION TYPE	BPSK	ENVIRONMENTAL CONDITIONS	21deg. C, 70%RH, 991hPa
TRANSFER RATE	6Mbps	INPUT POWER (SYSTEM)	120Vac, 60 Hz
TEST MODE	1	TESTED BY	Match Tsui

ANTENNA POLARITY & TEST DISTANCE: HORIZONTAL AT 3 M

No.	Freq. (MHz)	Emission Level (dBuV/m)	Limit (dBuV/m)	Margin (dB)	Antenna Height (m)	Table Angle (Degree)	Raw Value (dBuV)	Correction Factor (dB/m)
1	113.28	36.40 QP	43.50	-7.10	1.75 H	163	24.29	12.11
2	166.07	35.88 QP	43.50	-7.62	1.50 H	277	21.82	14.07
3	200.29	39.47 QP	43.50	-4.03	2.00 H	236	28.33	11.14
4	250.10	44.12 QP	46.00	-1.88	1.00 H	277	31.03	13.09
5	399.34	41.14 QP	46.00	-4.86	1.00 H	319	24.52	16.62
6	433.28	37.58 QP	46.00	-8.42	1.25 H	350	20.10	17.48
7	533.47	37.60 QP	46.00	-8.40	1.50 H	337	18.33	19.27
8	668.10	39.44 QP	46.00	-6.56	1.00 H	346	17.61	21.83
9	900.86	36.90 QP	46.00	-9.10	1.00 H	313	11.78	25.11
10	933.28	44.13 QP	46.00	-1.87	1.50 H	111	18.69	25.44

ANTENNA POLARITY & TEST DISTANCE: VERTICAL AT 3 M

No.	Freq. (MHz)	Emission Level (dBuV/m)	Limit (dBuV/m)	Margin (dB)	Antenna Height (m)	Table Angle (Degree)	Raw Value (dBuV)	Correction Factor (dB/m)
1	32.80	33.28 QP	40.00	-6.72	1.50 V	287	19.46	13.82
2	65.20	35.10 QP	40.00	-4.90	1.00 V	300	22.23	12.87
3	105.81	38.21 QP	43.50	-5.29	1.00 V	73	26.87	11.34
4	167.28	41.67 QP	43.50	-1.83	1.25 V	10	27.72	13.95
5	199.12	36.84 QP	43.50	-6.66	1.25 V	169	25.64	11.20
6	249.66	40.72 QP	46.00	-5.28	1.50 V	22	27.64	13.08
7	400.28	38.39 QP	46.00	-7.61	1.25 V	253	21.75	16.64
8	455.71	36.74 QP	46.00	-9.26	1.00 V	352	18.75	17.99
9	534.28	37.28 QP	46.00	-8.72	1.00 V	130	17.99	19.29
10	599.56	37.04 QP	46.00	-8.96	1.50 V	10	16.16	20.88
11	667.88	36.87 QP	46.00	-9.13	1.25 V	239	15.05	21.82
12	733.04	36.47 QP	46.00	-9.53	1.50 V	288	13.45	23.02
13	933.91	43.22 QP	46.00	-2.78	1.00 V	110	17.77	25.45

- REMARKS:**
1. Emission level(dBuV/m)=Raw Value(dBuV) + Correction Factor(dB/m)
 2. Correction Factor(dB/m) = Antenna Factor (dB/m) + Cable Factor (dB)
 3. The other emission levels were very low against the limit.
 4. Margin value = Emission level – Limit value.

Below 1GHz Worst-Case Data (Power from AC Adapter: NU20-5120200-I2)

EUT	VA4200 Wi-Fi AP/Bridge	MEASUREMENT DETAIL	
MODEL	VA4200	FREQUENCY RANGE	Below 1000MHz
CHANNEL	Channel 1	DETECTOR FUNCTION	Quasi-Peak
MODULATION TYPE	BPSK	ENVIRONMENTAL CONDITIONS	25deg. C, 68%RH, 991hPa
TRANSFER RATE	6Mbps	INPUT POWER (SYSTEM)	120Vac, 60 Hz
TEST MODE	2	TESTED BY	Match Tsui

ANTENNA POLARITY & TEST DISTANCE: HORIZONTAL AT 3 M

No.	Freq. (MHz)	Emission Level (dBuV/m)	Limit (dBuV/m)	Margin (dB)	Antenna Height (m)	Table Angle (Degree)	Raw Value (dBuV)	Correction Factor (dB/m)
1	107.76	41.00 QP	43.50	-2.50	2.50 H	70	29.46	11.54
2	166.07	40.99 QP	43.50	-2.51	2.50 H	70	26.93	14.07
3	199.12	35.97 QP	43.50	-7.53	1.50 H	349	24.77	11.20
4	249.66	43.85 QP	46.00	-2.15	1.00 H	193	30.77	13.08
5	333.25	38.27 QP	46.00	-7.73	1.00 H	328	23.19	15.08
6	366.29	39.00 QP	46.00	-7.00	1.00 H	304	23.15	15.84
7	399.34	44.10 QP	46.00	-1.90	1.00 H	295	27.48	16.62
8	533.47	37.41 QP	46.00	-8.59	1.50 H	10	18.14	19.27
9	580.12	37.38 QP	46.00	-8.62	1.50 H	22	17.00	20.38
10	667.60	39.52 QP	46.00	-6.48	1.00 H	10	17.70	21.82
11	799.78	39.88 QP	46.00	-6.12	1.00 H	10	16.18	23.70
12	900.86	36.28 QP	46.00	-9.72	1.50 H	232	11.17	25.11
13	933.91	42.57 QP	46.00	-3.43	1.50 H	349	17.12	25.45

ANTENNA POLARITY & TEST DISTANCE: VERTICAL AT 3 M

No.	Freq. (MHz)	Emission Level (dBuV/m)	Limit (dBuV/m)	Margin (dB)	Antenna Height (m)	Table Angle (Degree)	Raw Value (dBuV)	Correction Factor (dB/m)
1	31.94	34.85 QP	40.00	-5.15	1.00 V	103	21.17	13.68
2	64.99	30.42 QP	40.00	-9.58	1.50 V	319	17.53	12.90
3	105.81	34.32 QP	43.50	-9.18	1.00 V	250	22.97	11.34
4	166.07	31.97 QP	43.50	-11.53	1.00 V	88	17.91	14.07
5	249.66	34.63 QP	46.00	-11.37	1.50 V	112	21.55	13.08
6	399.34	39.61 QP	46.00	-6.39	2.00 V	67	22.99	16.62
7	533.47	34.92 QP	46.00	-11.08	1.50 V	289	15.65	19.27
8	599.56	33.67 QP	46.00	-12.33	1.00 V	211	12.79	20.88
9	667.60	38.41 QP	46.00	-7.59	1.50 V	340	16.59	21.82
10	799.78	33.74 QP	46.00	-12.26	1.50 V	250	10.04	23.70
11	900.86	33.63 QP	46.00	-12.37	1.00 V	328	8.51	25.11
12	933.91	41.18 QP	46.00	-4.82	1.00 V	322	15.74	25.45

- REMARKS:**
1. Emission level(dBuV/m)=Raw Value(dBuV) + Correction Factor(dB/m)
 2. Correction Factor(dB/m) = Antenna Factor (dB/m) + Cable Factor (dB)
 3. The other emission levels were very low against the limit.
 4. Margin value = Emission level – Limit value.

**Below 1GHz Worst-Case Data (Power from POE)**

EUT	VA4200 Wi-Fi AP/Bridge	MEASUREMENT DETAIL	
MODEL	VA4200	FREQUENCY RANGE	Below 1000MHz
CHANNEL	Channel 1	DETECTOR FUNCTION	Quasi-Peak
MODULATION TYPE	BPSK	ENVIRONMENTAL CONDITIONS	25deg. C, 68%RH, 991hPa
TRANSFER RATE	6Mbps	INPUT POWER (SYSTEM)	120Vac, 60 Hz
TEST MODE	3	TESTED BY	Match Tsui

ANTENNA POLARITY & TEST DISTANCE: HORIZONTAL AT 3 M

No.	Freq. (MHz)	Emission Level (dBuV/m)	Limit (dBuV/m)	Margin (dB)	Antenna Height (m)	Table Angle (Degree)	Raw Value (dBuV)	Correction Factor (dB/m)
1	58.05	36.14 QP	40.00	-3.86	1.75 H	236	22.49	13.65
2	105.98	36.44 QP	43.50	-7.06	1.50 H	217	25.08	11.36
3	143.29	39.11 QP	43.50	-4.39	1.50 H	183	24.82	14.29
4	250.17	44.12 QP	46.00	-1.88	1.00 H	269	31.03	13.09
5	300.20	37.50 QP	46.00	-8.50	1.00 H	328	23.17	14.33
6	399.34	41.46 QP	46.00	-4.54	1.00 H	31	24.84	16.62
7	600.08	38.40 QP	46.00	-7.60	2.00 H	187	17.50	20.90
8	667.60	37.47 QP	46.00	-8.53	1.00 H	16	15.65	21.82
9	933.91	41.80 QP	46.00	-4.20	1.00 H	19	16.35	25.45

ANTENNA POLARITY & TEST DISTANCE: VERTICAL AT 3 M

No.	Freq. (MHz)	Emission Level (dBuV/m)	Limit (dBuV/m)	Margin (dB)	Antenna Height (m)	Table Angle (Degree)	Raw Value (dBuV)	Correction Factor (dB/m)
1	43.58	38.20 QP	40.00	-1.80	1.25 V	178	23.17	15.03
2	105.60	41.53 QP	43.50	-1.97	1.00 V	289	30.21	11.32
3	143.28	39.11 QP	43.50	-4.39	1.00 V	29	24.82	14.29
4	249.66	41.61 QP	46.00	-4.39	1.00 V	52	28.53	13.08
5	399.34	37.47 QP	46.00	-8.53	1.75 V	307	20.85	16.62
6	500.10	39.40 QP	46.00	-6.60	1.00 V	300	20.81	18.59
7	600.27	37.80 QP	46.00	-8.20	1.50 V	147	16.90	20.90
8	799.78	36.19 QP	46.00	-9.81	1.50 V	262	12.49	23.70
9	934.10	44.21 QP	46.00	-1.79	1.50 V	321	18.76	25.45

- REMARKS:**
1. Emission level(dBuV/m)=Raw Value(dBuV) + Correction Factor(dB/m)
 2. Correction Factor(dB/m) = Antenna Factor (dB/m) + Cable Factor (dB)
 3. The other emission levels were very low against the limit.
 4. Margin value = Emission level – Limit value

802.11a OFDM modulation

EUT	VA4200 Wi-Fi AP/Bridge	MEASUREMENT DETAIL	
MODEL	VA4200	FREQUENCY RANGE	1 ~ 40 GHz
CHANNEL	Channel 1	DETECTOR FUNCTION	Peak(PK) Average (AV)
MODULATION TYPE	BPSK	ENVIRONMENTAL CONDITIONS	25deg.C, 68%RH, 991hPa
TRANSFER RATE	6Mbps	INPUT POWER (SYSTEM)	120Vac, 60 Hz
TESTED BY	Match Tsui		

ANTENNA POLARITY & TEST DISTANCE: HORIZONTAL AT 3 M

No.	Freq. (MHz)	Emission Level (dBuV/m)	Limit (dBuV/m)	Margin (dB)	Antenna Height (m)	Table Angle (Degree)	Raw Value (dBuV)	Correction Factor (dB/m)
1	#1066.00	46.62 PK	74.00	-27.38	1.35 H	58	19.86	26.76
1	#1066.00	42.02 AV	54.00	-11.98	1.35 H	58	15.26	26.76
2	3453.00	42.62 PK	68.30	-25.68	1.02 H	235	9.74	32.88
3	#5150.00	60.80 PK	74.00	-13.20	1.02 H	80	23.74	37.05
3	#5150.00	50.01 AV	54.00	-3.99	1.02 H	80	12.95	37.05
4	*5180.00	105.41 PK			1.02 H	80	68.32	37.09
4	*5180.00	94.53 AV			1.02 H	80	57.44	37.09
5	6906.00	49.64 PK	68.30	-18.66	1.28 H	44	8.07	41.57
6	10360.00	58.33 PK	68.30	-9.97	1.27 H	34	12.27	46.06

ANTENNA POLARITY & TEST DISTANCE: VERTICAL AT 3 M

No.	Freq. (MHz)	Emission Level (dBuV/m)	Limit (dBuV/m)	Margin (dB)	Antenna Height (m)	Table Angle (Degree)	Raw Value (dBuV)	Correction Factor (dB/m)
1	#1066.00	49.01 PK	74.00	-24.99	1.00 V	274	22.25	26.76
1	#1066.00	44.94 AV	54.00	-9.06	1.00 V	274	18.18	26.76
2	3453.00	42.47 PK	68.30	-25.83	1.28 V	237	9.59	32.88
3	#5150.00	60.38 PK	74.00	-13.62	1.33 V	164	23.33	37.05
3	#5150.00	51.24 AV	54.00	-2.76	1.33 V	164	14.19	37.05
4	*5180.00	107.21 PK			1.33 V	164	70.12	37.09
4	*5180.00	96.24 AV			1.33 V	164	59.15	37.09
5	6906.00	50.07 PK	68.30	-18.23	1.50 V	61	8.50	41.57
6	10360.00	60.59 PK	68.30	-7.71	1.02 V	354	14.53	46.06

- NOTE:**
1. Emission level(dBuV/m)=Raw Value(dBuV) + Correction Factor(dB/m)
 2. Correction Factor(dB/m) = Antenna Factor (dB/m) + Cable Factor (dB)
 3. The other emission levels were very low against the limit.
 4. Margin value = Emission level – Limit value
 5. "*" : Fundamental frequency
 6. "#": The radiated frequency falling in the restricted band.



EUT	VA4200 Wi-Fi AP/Bridge	MEASUREMENT DETAIL	
MODEL	VA4200	FREQUENCY RANGE	1 ~ 40 GHz
CHANNEL	Channel 4	DETECTOR FUNCTION	Peak(PK) Average (AV)
MODULATION TYPE	BPSK	ENVIRONMENTAL CONDITIONS	25deg.C, 68%RH, 991hPa
TRANSFER RATE	6Mbps	INPUT POWER (SYSTEM)	120Vac, 60 Hz
TESTED BY	Match Tsui		

ANTENNA POLARITY & TEST DISTANCE: HORIZONTAL AT 3 M								
No.	Freq. (MHz)	Emission Level (dBuV/m)	Limit (dBuV/m)	Margin (dB)	Antenna Height (m)	Table Angle (Degree)	Raw Value (dBuV)	Correction Factor (dB/m)
1	#1066.00	46.43 PK	74.00	-27.57	1.44 H	11	19.67	26.76
1	#1066.00	41.44 AV	54.00	-12.56	1.44 H	11	14.68	26.76
2	*5240.00	103.81 PK			1.04 H	180	66.61	37.20
2	*5240.00	93.61 AV			1.04 H	180	56.41	37.20
3	10480.00	56.51 PK	68.30	-11.79	1.16 H	323	10.15	46.36

ANTENNA POLARITY & TEST DISTANCE: VERTICAL AT 3 M								
No.	Freq. (MHz)	Emission Level (dBuV/m)	Limit (dBuV/m)	Margin (dB)	Antenna Height (m)	Table Angle (Degree)	Raw Value (dBuV)	Correction Factor (dB/m)
1	#1066.00	47.26 PK	74.00	-26.74	1.07 V	238	20.50	26.76
1	#1066.00	43.66 AV	54.00	-10.34	1.07 V	238	16.90	26.76
2	*5240.00	105.85 PK			1.13 V	360	68.65	37.20
2	*5240.00	95.53 AV			1.13 V	360	58.33	37.20
3	10480.00	65.26 PK	68.30	-3.04	1.28 V	99	18.90	46.36

- NOTE:**
1. Emission level(dBuV/m)=Raw Value(dBuV) + Correction Factor(dB/m)
 2. Correction Factor(dB/m) = Antenna Factor (dB/m) + Cable Factor (dB)
 3. The other emission levels were very low against the limit.
 4. Margin value = Emission level – Limit value
 5. "*" : Fundamental frequency
 6. "#":The radiated frequency falling in the restricted band.



EUT	VA4200 Wi-Fi AP/Bridge	MEASUREMENT DETAIL	
MODEL	VA4200	FREQUENCY RANGE	1 ~ 40 GHz
CHANNEL	Channel 5	DETECTOR FUNCTION	Peak(PK) Average (AV)
MODULATION TYPE	BPSK	ENVIRONMENTAL CONDITIONS	25deg.C, 68%RH, 991hPa
TRANSFER RATE	6Mbps	INPUT POWER (SYSTEM)	120Vac, 60 Hz
TESTED BY	Match Tsui		

ANTENNA POLARITY & TEST DISTANCE: HORIZONTAL AT 3 M								
No.	Freq. (MHz)	Emission Level (dBuV/m)	Limit (dBuV/m)	Margin (dB)	Antenna Height (m)	Table Angle (Degree)	Raw Value (dBuV)	Correction Factor (dB/m)
1	#1066.00	47.50 PK	74.00	-26.50	1.40 H	57	20.74	26.76
1	#1066.00	43.01 AV	54.00	-10.99	1.40 H	57	16.25	26.76
2	*5260.00	105.60 PK			1.00 H	65	68.35	37.25
2	*5260.00	95.70 AV			1.00 H	65	58.45	37.25
3	10520.00	60.50 PK	68.30	-7.80	1.16 H	242	14.02	46.48

ANTENNA POLARITY & TEST DISTANCE: VERTICAL AT 3 M								
No.	Freq. (MHz)	Emission Level (dBuV/m)	Limit (dBuV/m)	Margin (dB)	Antenna Height (m)	Table Angle (Degree)	Raw Value (dBuV)	Correction Factor (dB/m)
1	#1066.00	50.59 PK	74.00	-23.41	1.04 V	275	23.83	26.76
1	#1066.00	46.45 AV	54.00	-7.55	1.04 V	275	19.69	26.76
2	*5260.00	108.20 PK			1.03 V	165	70.95	37.25
2	*5260.00	99.40 AV			1.03 V	165	62.15	37.25
3	10520.00	64.47 PK	68.30	-3.83	1.00 V	130	17.99	46.48

- NOTE:**
1. Emission level(dBuV/m)=Raw Value(dBuV) + Correction Factor(dB/m)
 2. Correction Factor(dB/m) = Antenna Factor (dB/m) + Cable Factor (dB)
 3. The other emission levels were very low against the limit.
 4. Margin value = Emission level – Limit value
 5. “*” : Fundamental frequency
 6. “#”The radiated frequency falling in the restricted band.



EUT	VA4200 Wi-Fi AP/Bridge	MEASUREMENT DETAIL	
MODEL	VA4200	FREQUENCY RANGE	1 ~ 40 GHz
CHANNEL	Channel 8	DETECTOR FUNCTION	Peak(PK) Average (AV)
MODULATION TYPE	BPSK	ENVIRONMENTAL CONDITIONS	25deg.C, 68%RH, 991hPa
TRANSFER RATE	6Mbps	INPUT POWER (SYSTEM)	120Vac, 60 Hz
TESTED BY	Match Tsui		

ANTENNA POLARITY & TEST DISTANCE: HORIZONTAL AT 3 M								
No.	Freq. (MHz)	Emission Level (dBuV/m)	Limit (dBuV/m)	Margin (dB)	Antenna Height (m)	Table Angle (Degree)	Raw Value (dBuV)	Correction Factor (dB/m)
1	#1066.00	46.67 PK	74.00	-27.33	1.43 H	11	19.91	26.76
1	#1066.00	41.69 AV	54.00	-12.31	1.43 H	11	14.93	26.76
2	*5320.00	103.40 PK			1.04 H	183	66.04	37.36
2	*5320.00	92.53 AV			1.04 H	183	55.17	37.36
3	#5350.00	57.50 PK	74.00	-16.50	1.04 H	183	20.11	37.39
3	#5350.00	46.80 AV	54.00	-7.20	1.04 H	183	9.41	37.39
4	#10640.00	58.02 PK	74.00	-15.98	1.53 H	153	11.30	46.72
4	#10640.00	45.65 AV	54.00	-8.35	1.53 H	153	-1.07	46.72

ANTENNA POLARITY & TEST DISTANCE: VERTICAL AT 3 M								
No.	Freq. (MHz)	Emission Level (dBuV/m)	Limit (dBuV/m)	Margin (dB)	Antenna Height (m)	Table Angle (Degree)	Raw Value (dBuV)	Correction Factor (dB/m)
1	#1066.00	45.31 PK	74.00	-28.69	1.45 V	346	18.55	26.76
1	#1066.00	40.09 AV	54.00	-13.91	1.45 V	346	13.33	26.76
2	*5320.00	107.86 PK			1.30 V	169	70.50	37.36
2	*5320.00	97.83 AV			1.30 V	169	60.47	37.36
3	#5350.00	61.75 PK	74.00	-12.25	1.30 V	169	24.36	37.39
3	#5350.00	51.23 AV	54.00	-2.77	1.30 V	169	13.84	37.39
4	#10640.00	64.16 PK	74.00	-9.84	1.25 V	301	17.44	46.72
4	#10640.00	51.00 AV	54.00	-3.00	1.25 V	301	4.28	46.72

- NOTE:**
1. Emission level(dBuV/m)=Raw Value(dBuV) + Correction Factor(dB/m)
 2. Correction Factor(dB/m) = Antenna Factor (dB/m) + Cable Factor (dB)
 3. The other emission levels were very low against the limit.
 4. Margin value = Emission level – Limit value
 5. "*" : Fundamental frequency
 6. "#" The radiated frequency falling in the restricted band.

802.11a Turbo OFDM modulation

EUT	VA4200 Wi-Fi AP/Bridge	MEASUREMENT DETAIL	
MODEL	VA4200	FREQUENCY RANGE	1 ~ 40 GHz
CHANNEL	Channel 1	DETECTOR FUNCTION	Peak(PK) Average (AV)
MODULATION TYPE	BPSK	ENVIRONMENTAL CONDITIONS	22deg.C, 60%RH, 991hPa
TRANSFER RATE	12Mbps	INPUT POWER (SYSTEM)	120Vac, 60 Hz
TESTED BY	Long Chen		

ANTENNA POLARITY & TEST DISTANCE: HORIZONTAL AT 3 M

No.	Freq. (MHz)	Emission Level (dBuV/m)	Limit (dBuV/m)	Margin (dB)	Antenna Height (m)	Table Angle (Degree)	Raw Value (dBuV)	Correction Factor (dB/m)
1	#5150.00	55.22 PK	74.00	-18.78	1.25 H	116	18.16	37.05
1	#5150.00	44.79 AV	54.00	-9.21	1.25 H	116	7.73	37.05
2	*5210.00	101.97 PK			1.25 H	116	64.84	37.13
2	*5210.00	91.54 AV			1.25 H	116	54.41	37.13
3	6946.00	51.06 PK	68.30	-17.24	1.15 H	209	9.40	41.66
4	10420.00	55.59 PK	68.30	-12.71	1.10 H	289	9.47	46.12

ANTENNA POLARITY & TEST DISTANCE: VERTICAL AT 3 M

No.	Freq. (MHz)	Emission Level (dBuV/m)	Limit (dBuV/m)	Margin (dB)	Antenna Height (m)	Table Angle (Degree)	Raw Value (dBuV)	Correction Factor (dB/m)
1	#5150.00	57.34 PK	74.00	-16.66	1.26 V	113	20.29	37.05
1	#5150.00	47.29 AV	54.00	-6.71	1.26 V	113	10.23	37.05
2	*5210.00	104.09 PK			1.26 V	113	66.96	37.13
2	*5210.00	94.04 AV			1.26 V	113	56.91	37.13
3	6946.00	54.93 PK	68.30	-13.37	1.12 V	279	13.27	41.66
4	10420.00	62.24 PK	68.30	-6.06	1.62 V	107	16.12	46.12

- NOTE:**
1. Emission level(dBuV/m)=Raw Value(dBuV) + Correction Factor(dB/m)
 2. Correction Factor(dB/m) = Antenna Factor (dB/m) + Cable Factor (dB)
 3. The other emission levels were very low against the limit.
 4. Margin value = Emission level – Limit value
 5. "*" : Fundamental frequency
 6. "#"The radiated frequency falling in the restricted band.



EUT	VA4200 Wi-Fi AP/Bridge	MEASUREMENT DETAIL	
MODEL	VA4200	FREQUENCY RANGE	1 ~ 40 GHz
CHANNEL	Channel 2	DETECTOR FUNCTION	Peak(PK) Average (AV)
MODULATION TYPE	BPSK	ENVIRONMENTAL CONDITIONS	22deg.C, 60%RH, 991hPa
TRANSFER RATE	12Mbps	INPUT POWER (SYSTEM)	120Vac, 60 Hz
TESTED BY	Long Chen		

ANTENNA POLARITY & TEST DISTANCE: HORIZONTAL AT 3 M

No.	Freq. (MHz)	Emission Level (dBuV/m)	Limit (dBuV/m)	Margin (dB)	Antenna Height (m)	Table Angle (Degree)	Raw Value (dBuV)	Correction Factor (dB/m)
1	*5250.00	102.03 PK			1.02 H	114	64.81	37.23
1	*5250.00	92.33 AV			1.02 H	114	55.10	37.23
2	7000.00	42.10 PK	68.30	-26.20	1.08 H	263	0.33	41.77
3	10500.00	57.27 PK	68.30	-11.03	1.18 H	287	10.83	46.44

ANTENNA POLARITY & TEST DISTANCE: VERTICAL AT 3 M

No.	Freq. (MHz)	Emission Level (dBuV/m)	Limit (dBuV/m)	Margin (dB)	Antenna Height (m)	Table Angle (Degree)	Raw Value (dBuV)	Correction Factor (dB/m)
1	*5250.00	104.57 PK			1.02 V	116	67.35	37.23
1	*5250.00	94.84 AV			1.02 V	116	57.61	37.23
2	7000.00	52.38 PK	68.30	-15.92	1.16 V	197	10.61	41.77
3	10500.00	63.56 PK	68.30	-4.74	1.62 V	104	17.12	46.44

- NOTE:**
1. Emission level(dBuV/m)=Raw Value(dBuV) + Correction Factor(dB/m)
 2. Correction Factor(dB/m) = Antenna Factor (dB/m) + Cable Factor (dB)
 3. The other emission levels were very low against the limit.
 4. Margin value = Emission level – Limit value
 5. "*" : Fundamental frequency
 6. "#" The radiated frequency falling in the restricted band.



EUT	VA4200 Wi-Fi AP/Bridge	MEASUREMENT DETAIL	
MODEL	VA4200	FREQUENCY RANGE	1 ~ 40 GHz
CHANNEL	Channel 3	DETECTOR FUNCTION	Peak(PK) Average (AV)
MODULATION TYPE	BPSK	ENVIRONMENTAL CONDITIONS	22deg.C, 60%RH, 991hPa
TRANSFER RATE	12Mbps	INPUT POWER (SYSTEM)	120Vac, 60 Hz
TESTED BY	Long Chen		

ANTENNA POLARITY & TEST DISTANCE: HORIZONTAL AT 3 M								
No.	Freq. (MHz)	Emission Level (dBuV/m)	Limit (dBuV/m)	Margin (dB)	Antenna Height (m)	Table Angle (Degree)	Raw Value (dBuV)	Correction Factor (dB/m)
1	*5290.00	101.67 PK			1.25 H	114	64.35	37.32
1	*5290.00	91.35 AV			1.25 H	114	54.03	37.32
2	#5350.00	56.75 PK	74.00	-17.25	1.25 H	114	19.36	37.39
2	#5350.00	46.43 AV	54.00	-7.57	1.25 H	114	9.04	37.39
3	7053.00	49.21 PK	68.30	-19.09	1.53 H	11	7.36	41.85
4	10580.00	55.97 PK	68.30	-12.33	1.00 H	3	9.38	46.58

ANTENNA POLARITY & TEST DISTANCE: VERTICAL AT 3 M								
No.	Freq. (MHz)	Emission Level (dBuV/m)	Limit (dBuV/m)	Margin (dB)	Antenna Height (m)	Table Angle (Degree)	Raw Value (dBuV)	Correction Factor (dB/m)
1	*5290.00	104.08 PK			1.42 V	163	66.76	37.32
1	*5290.00	94.02 AV			1.42 V	163	56.70	37.32
2	#5350.00	59.16 PK	74.00	-14.84	1.42 V	163	21.77	37.39
2	#5350.00	49.10 AV	54.00	-4.90	1.42 V	163	11.71	37.39
3	7053.00	52.23 PK	68.30	-16.07	1.13 V	259	10.38	41.85
4	10580.00	62.89 PK	68.30	-5.41	1.00 V	28	16.31	46.58

- NOTE:**
1. Emission level(dBuV/m)=Raw Value(dBuV) + Correction Factor(dB/m)
 2. Correction Factor(dB/m) = Antenna Factor (dB/m) + Cable Factor (dB)
 3. The other emission levels were very low against the limit.
 4. Margin value = Emission level – Limit value
 5. "*" : Fundamental frequency
 6. "#": The radiated frequency falling in the restricted band.



4.3 PEAK TRANSMIT POWER MEASUREMENT

4.3.1 LIMITS OF PEAK TRANSMIT POWER MEASUREMENT

Frequency Band	Limit
5.15 – 5.25GHz	The lesser of 50mW (17dBm) or 4dBm + 10logB
5.25 – 5.35GHz	The lesser of 250mW (24dBm) or 11dBm + 10logB
5.725 – 5.825GHz	The lesser of 1W (30dBm) or 17dBm + 10logB

NOTE: Where B is the 26dB emission bandwidth in MHz.

4.3.2 TEST INSTRUMENTS

Description & Manufacturer	Model No.	Serial No.	Calibrated Until
R&S SPECTRUM ANALYZER	FSEK30	100049	Aug. 12, 2005

NOTE: The calibration interval of the above test instruments is 12 months and the calibrations are traceable to NML/ROC and NIST/USA.

4.3.3 TEST PROCEDURE

1. The transmitter output was connected to the spectrum analyzer.
2. Set span to encompass the entire emission bandwidth of the signal.
3. Set RBW to 1MHz, VBW to 3MHz.
4. Using the spectrum analyzer's channel power measurement function to measure the output power.

NOTE:

The test is performed in accordance with FCC Public Notice: APPENDIX A Guidelines for Assessing Unlicensed National Information Infrastructure (U-NII) Devices – Part 15, Subpart E, August 2002.

The transmitter output operates continuously therefore Method # 1 is used.

4.3.4 DEVIATION FROM TEST STANDARD

No deviation

4.3.5 TEST SETUP

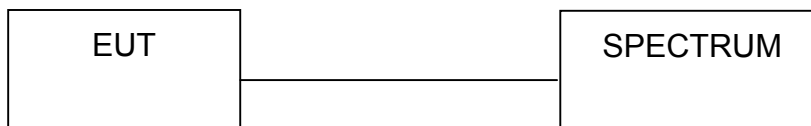

4.3.6 EUT OPERATING CONDITIONS

The software provided by client to enable the EUT under transmission condition continuously at specific channel frequencies individually.

4.3.7 TEST RESULTS

802.11a OFDM modulation

EUT	VA4200 Wi-Fi AP/Bridge	MODEL	VA4200
MODULATION TYPE	BPSK	TRANSFER RATE	6Mbps
INPUT POWER (SYSTEM)	120Vac, 60 Hz	ENVIRONMENTAL CONDITIONS	25deg.C, 63%RH, 991hPa
TESTED BY	Long Chen		

CHANNEL	CHANNEL FREQUENCY (MHz)	PEAK POWER OUTPUT (mW)	PEAK POWER OUTPUT (dBm)	PEAK POWER LIMIT (dBm)	26dBc Occupied Bandwidth (MHz)	PASS/FAIL
1	5180	45.499	16.58	17.00	26.10	PASS
4	5240	37.411	15.73	17.00	25.74	PASS
5	5260	63.973	18.06	24.00	28.53	PASS
8	5320	35.727	15.53	24.00	25.74	PASS

NOTE: The 26dBc Occupied Bandwidth plot, please refer to the following pages.



Peak Power Output:
CH 1

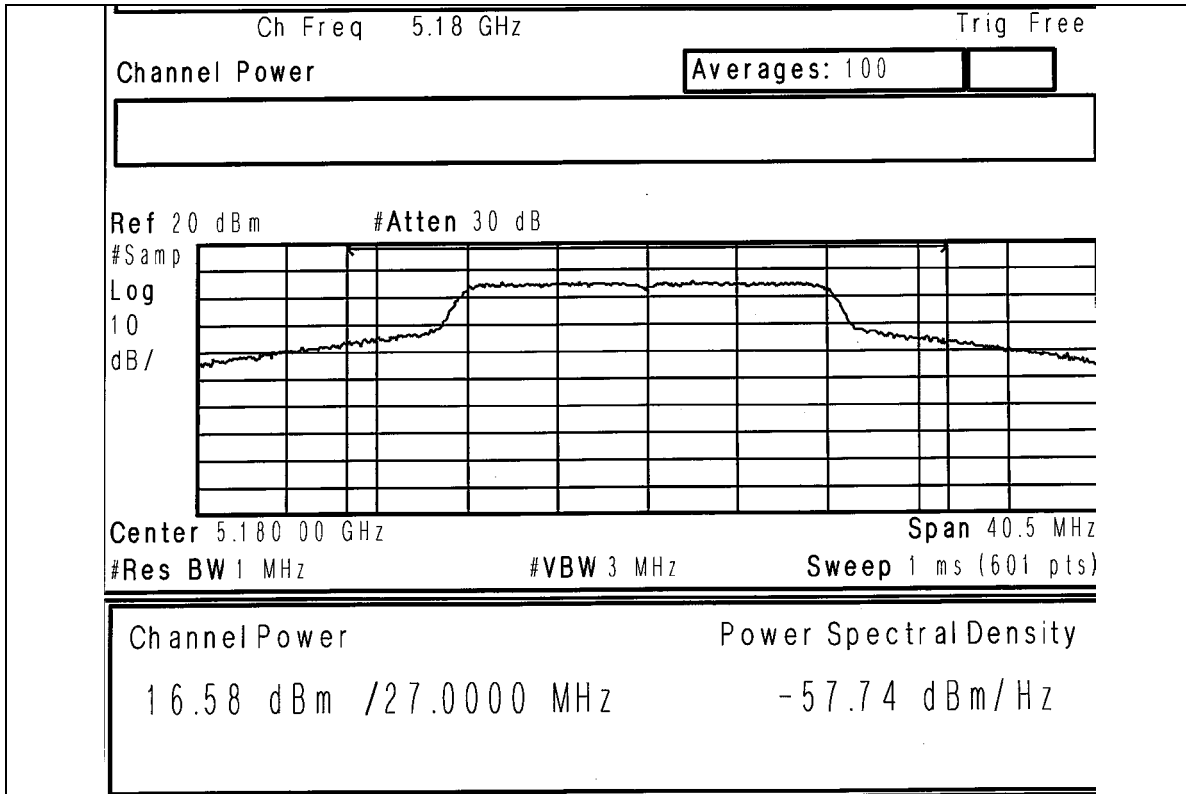

CH 4

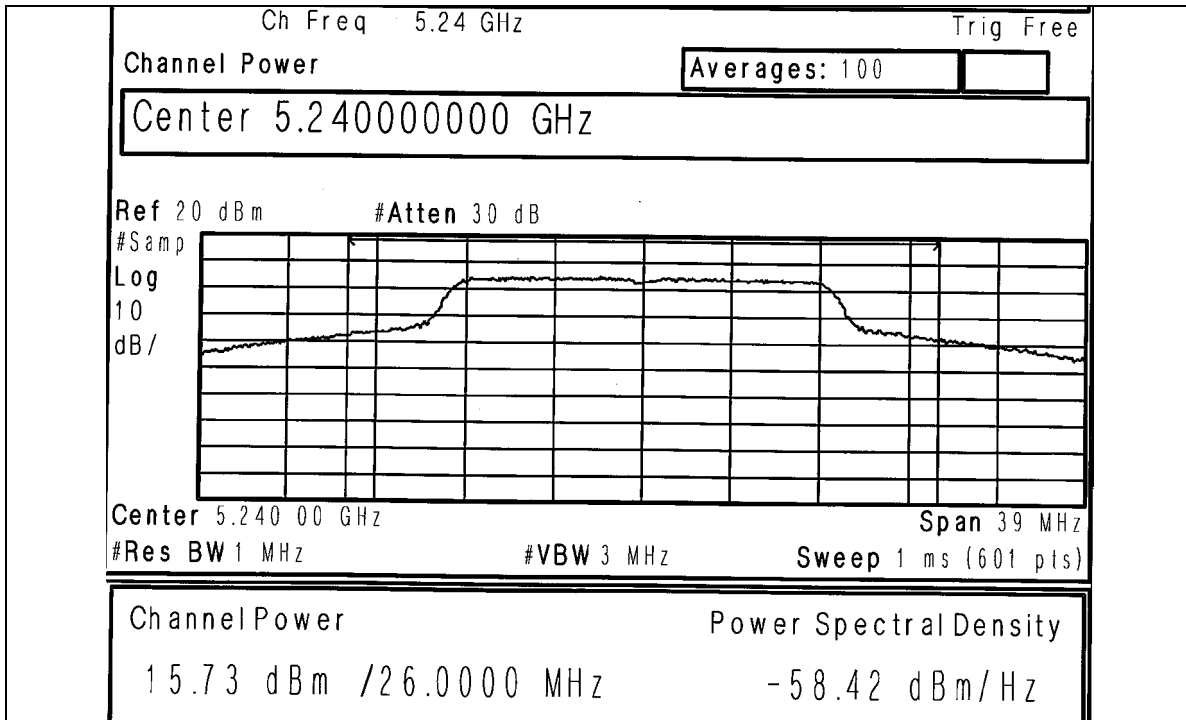



CH 5

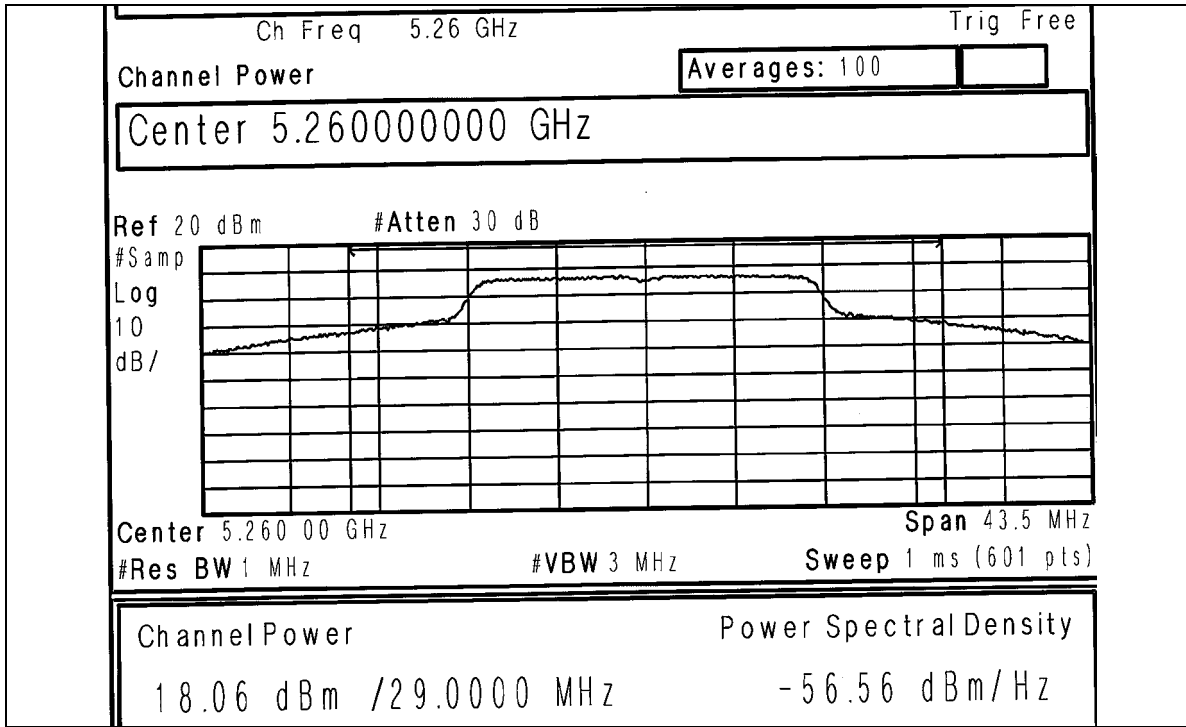

CH 8

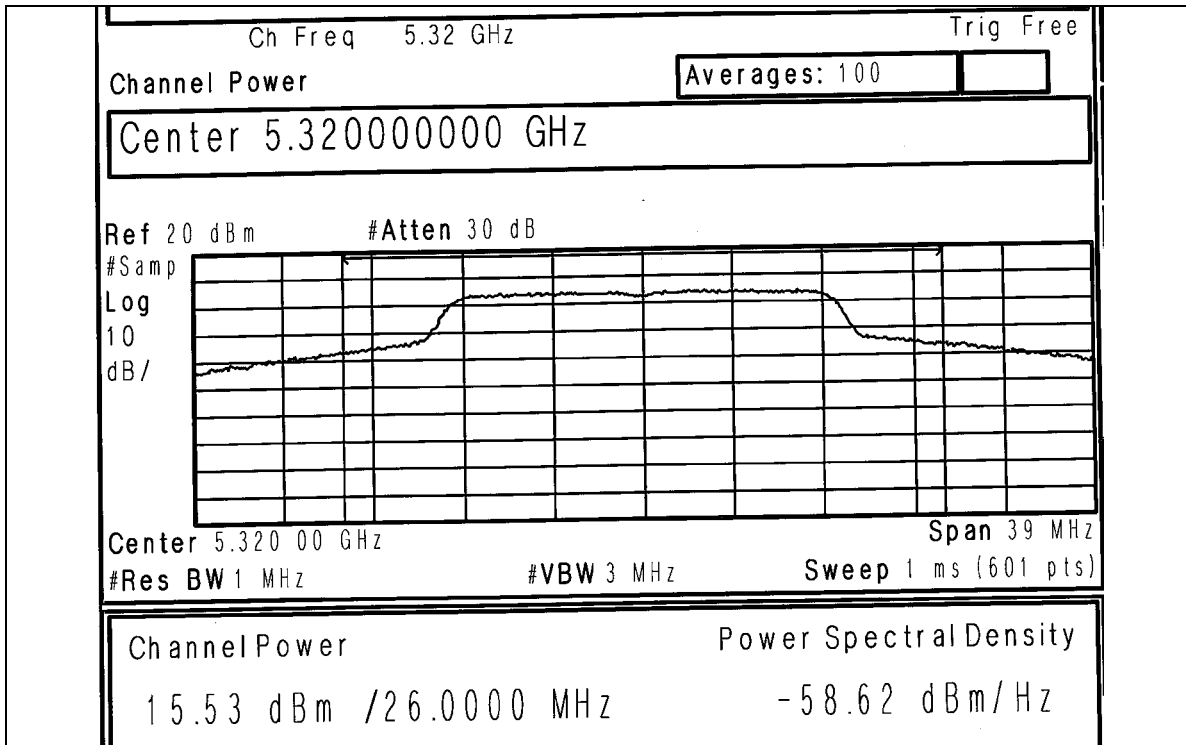



26dB Occupied Bandwidth:
CH 1

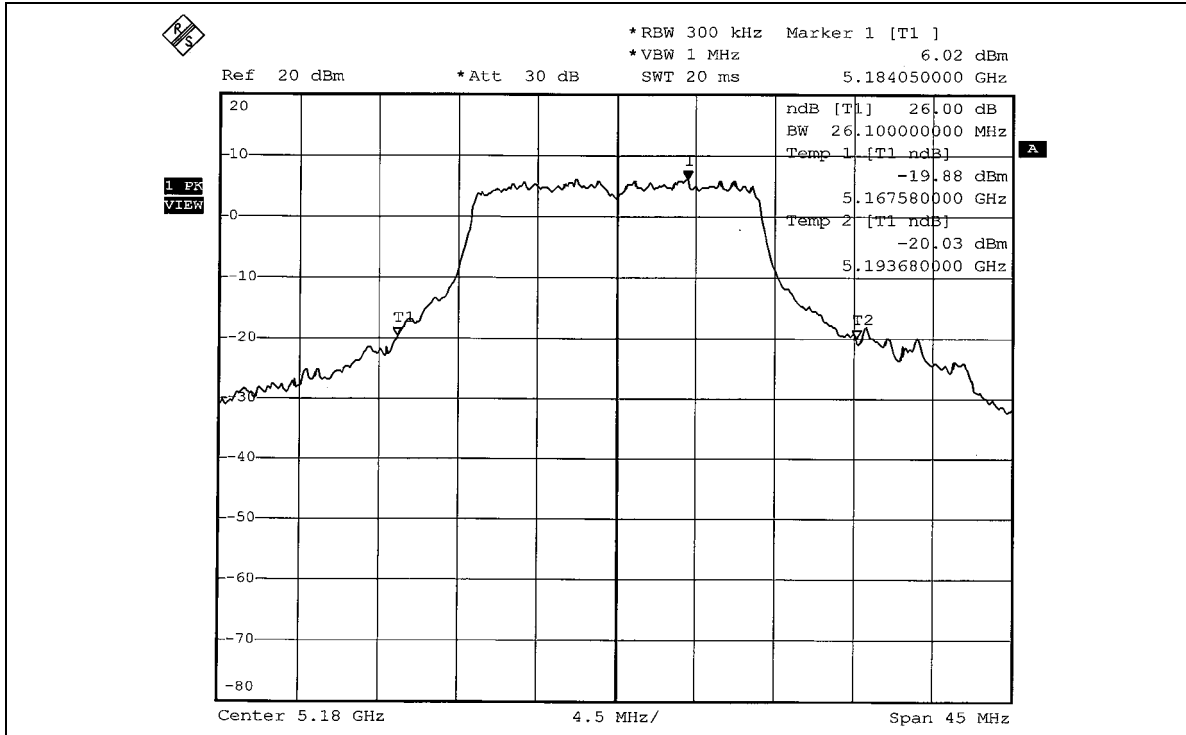

CH 4

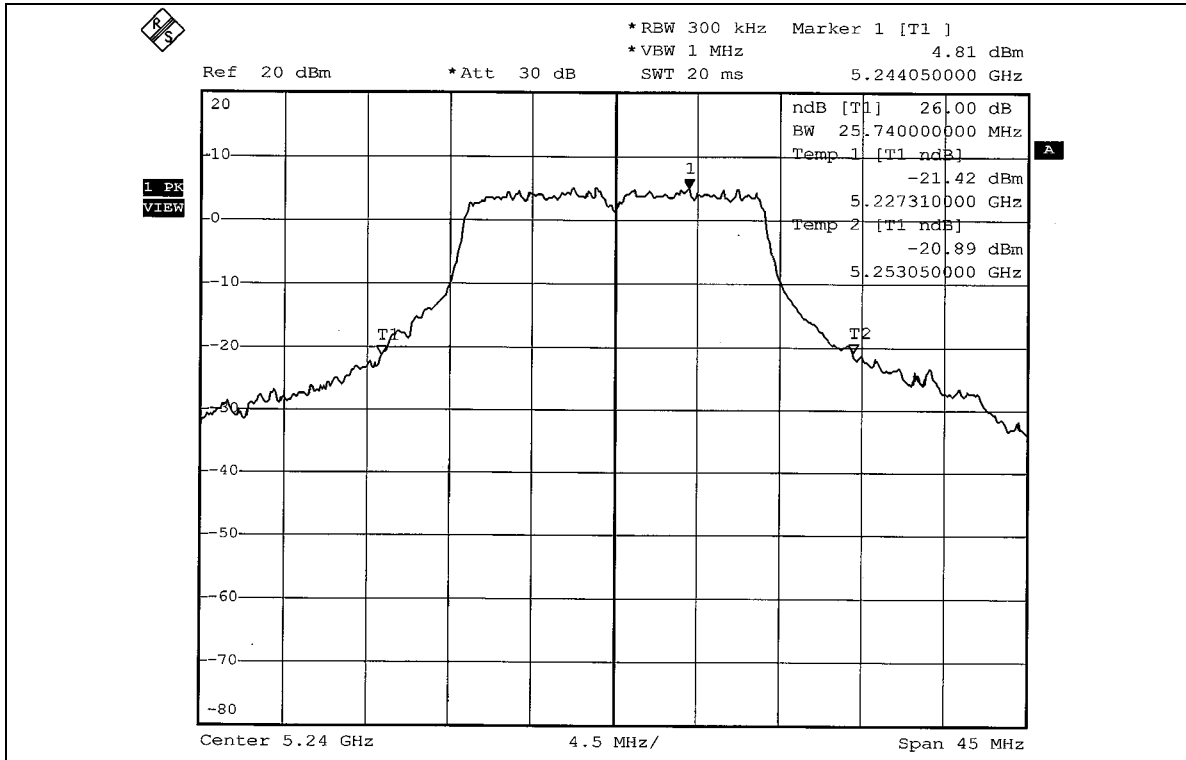



CH 5

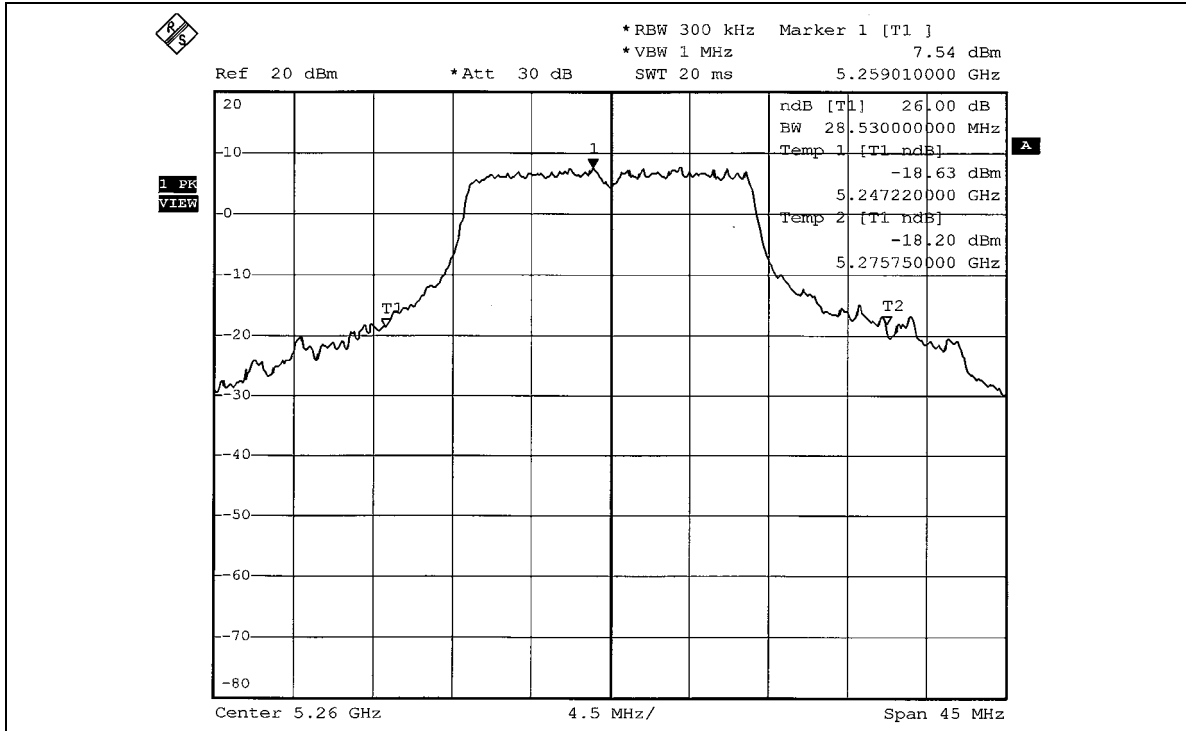

CH 8

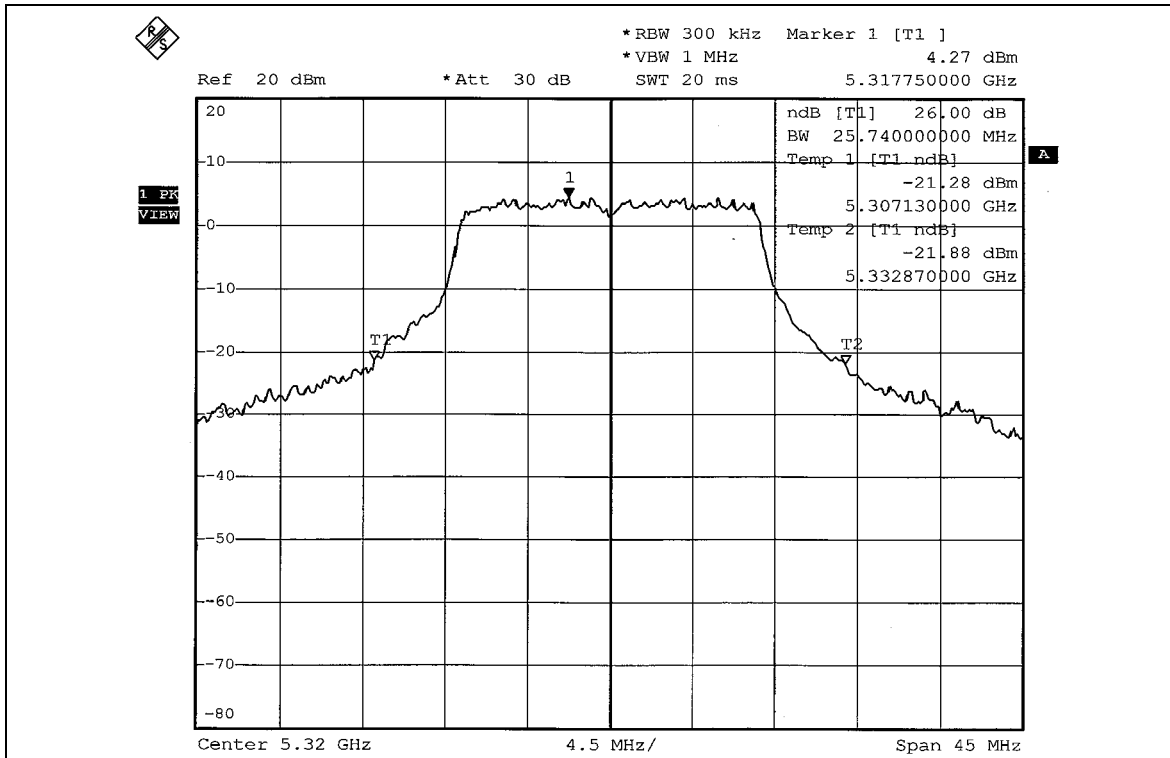

**802.11a Turbo OFDM modulation**

EUT	VA4200 Wi-Fi AP/Bridge	MODEL	VA4200
MODULATION TYPE	BPSK	TRANSFER RATE	12Mbps
INPUT POWER (SYSTEM)	120Vac, 60 Hz	ENVIRONMENTAL CONDITIONS	25deg.C, 63%RH, 991hPa
TESTED BY	Long Chen		

CHANNEL	CHANNEL FREQUENCY (MHz)	PEAK POWER OUTPUT (mW)	PEAK POWER OUTPUT (dBm)	PEAK POWER LIMIT (dBm)	26dBc Occupied Bandwidth (MHz)	PASS/FAIL
1	5210	42.855	16.32	17.00	68.04	PASS
2	5250	42.855	16.32	17.00	66.60	PASS
3	5290	45.394	16.57	24.00	69.84	PASS

NOTE: The 26dBc Occupied Bandwidth plot, please refer to the following pages.



Peak Power Output:

CH 1

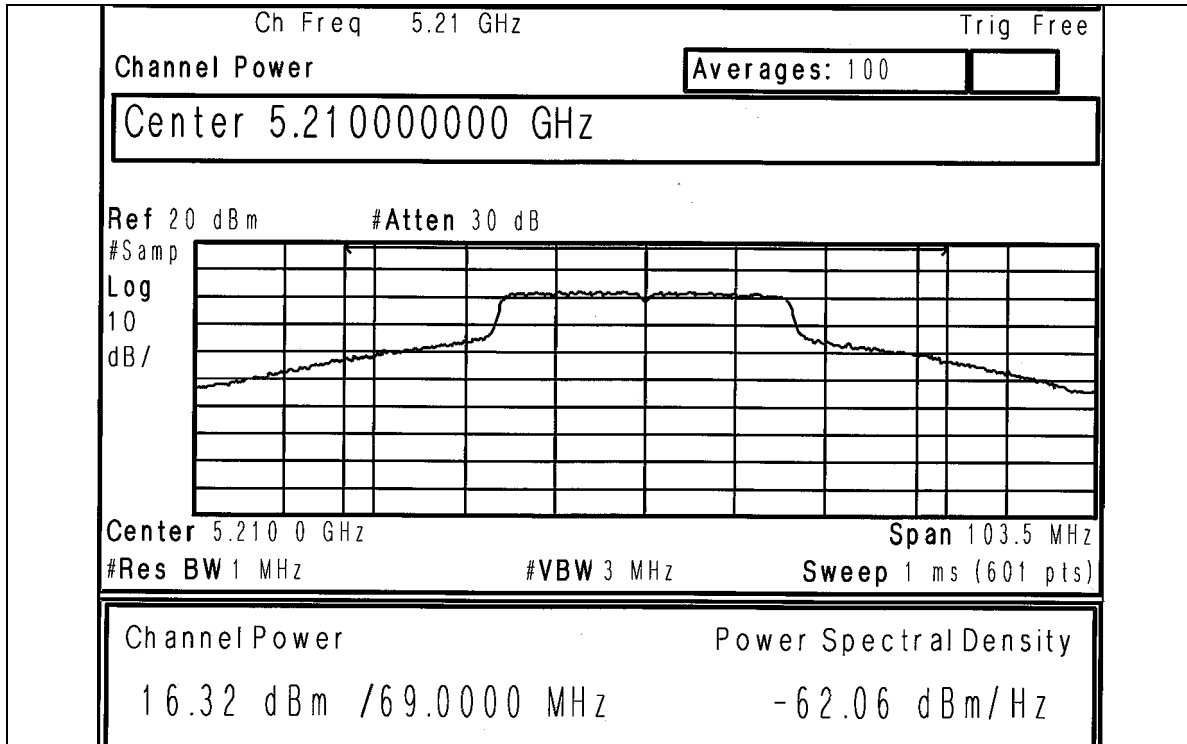

CH 2

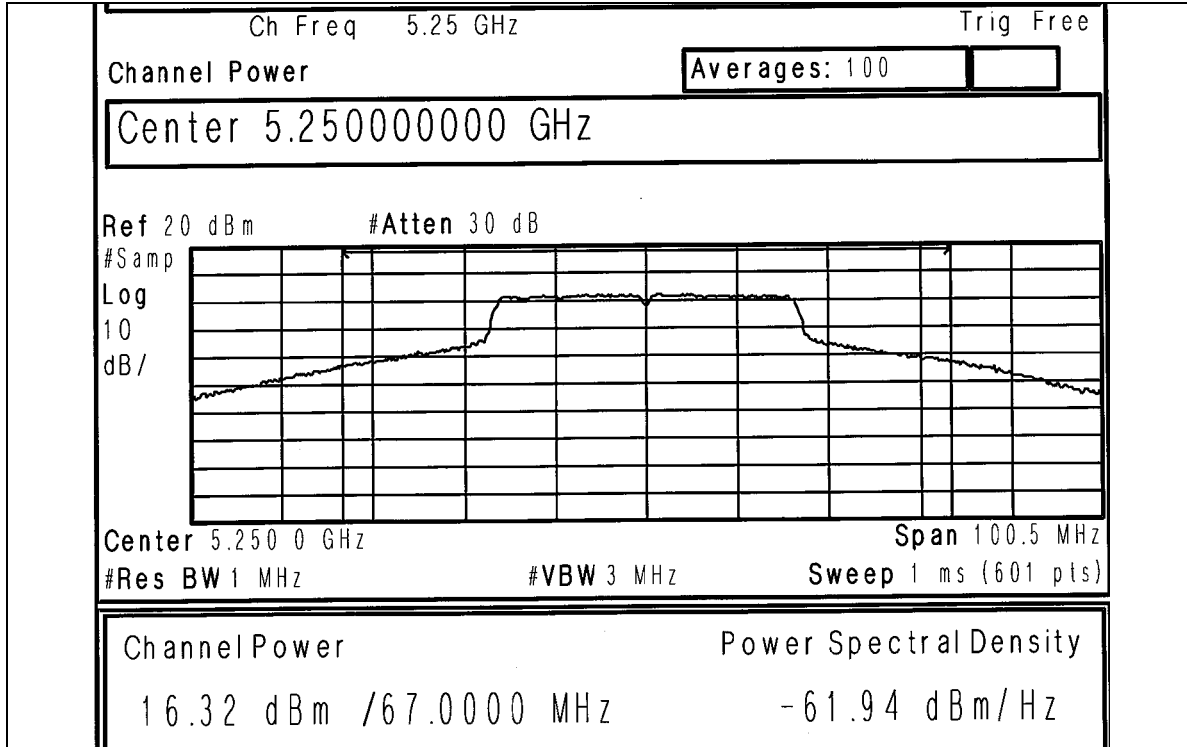



CH 3

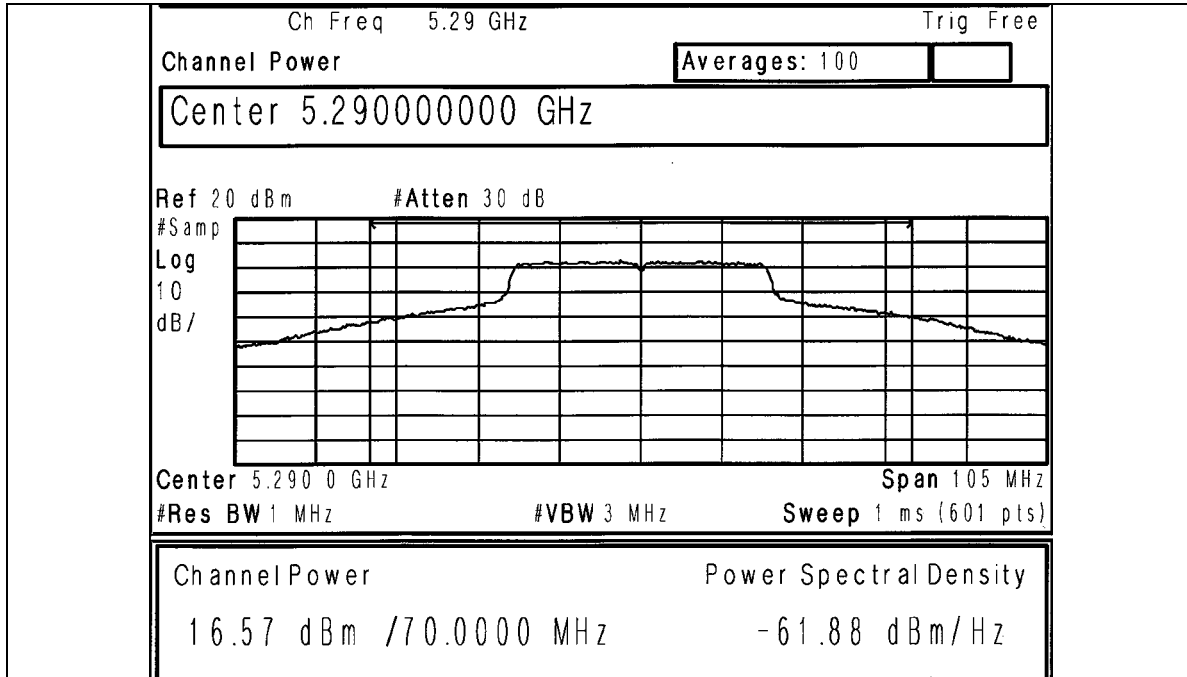



26dB Occupied Bandwidth:
CH 1

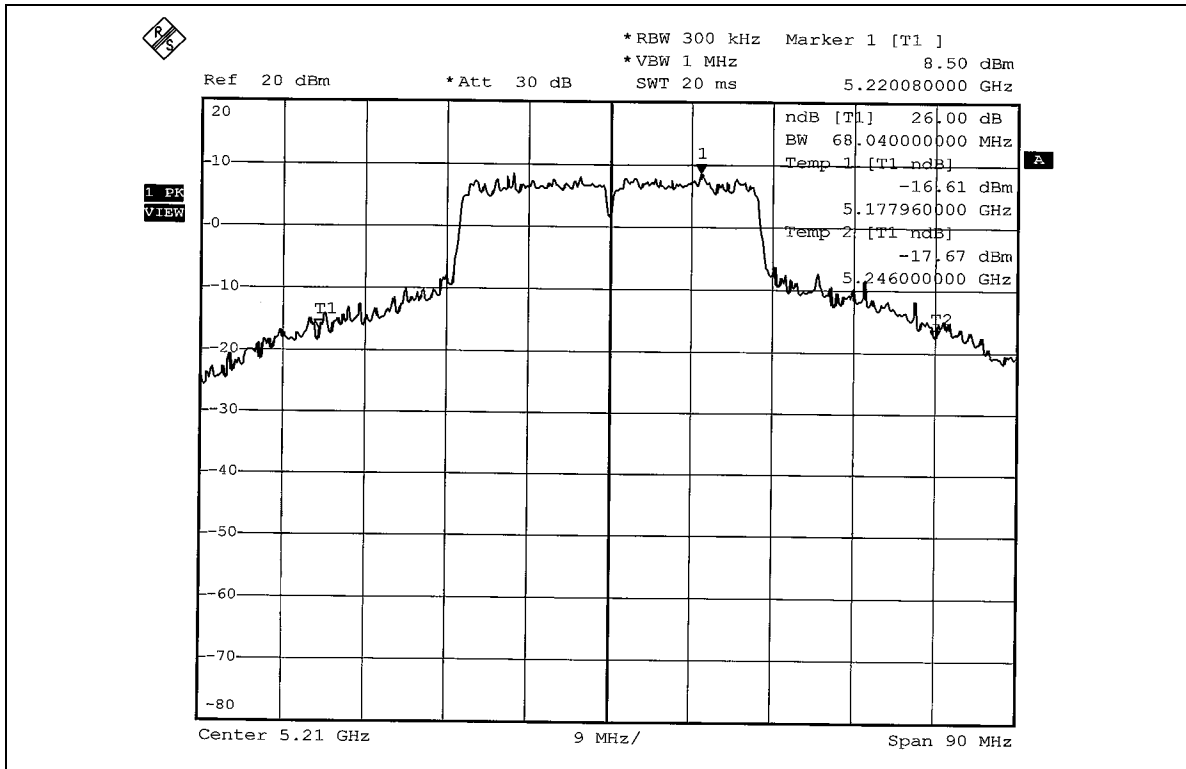

CH 2

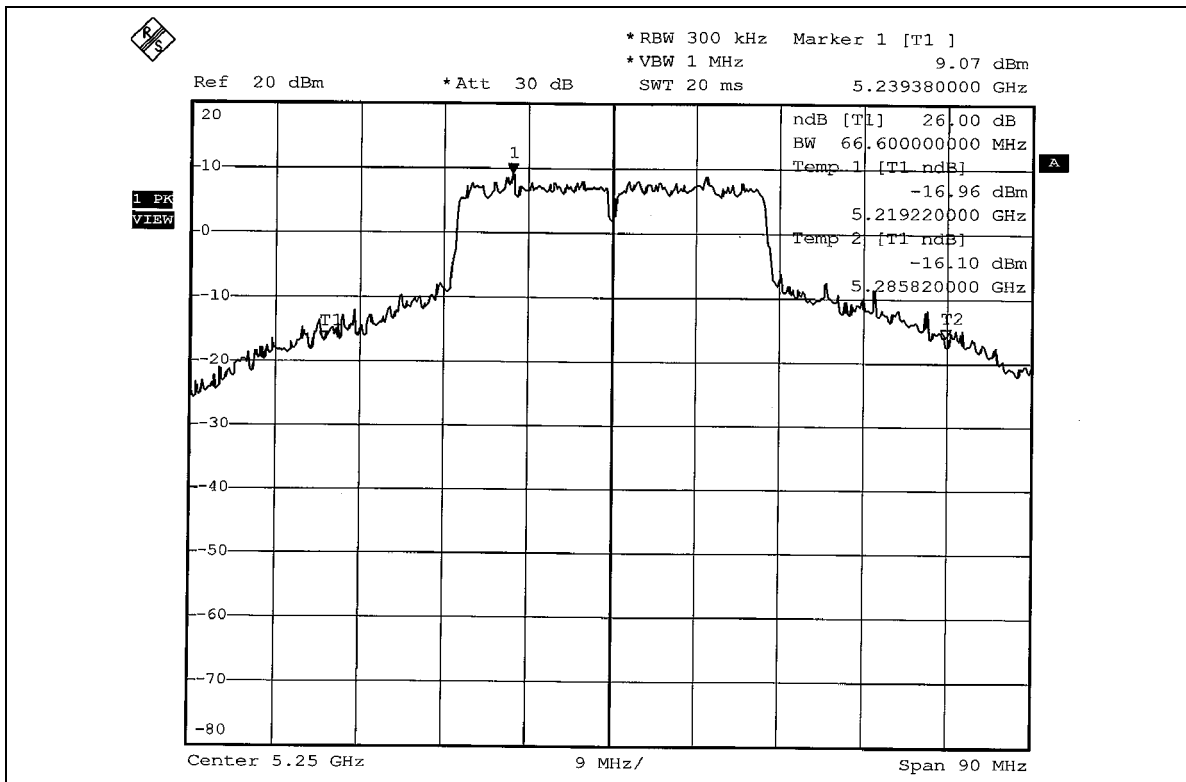



CH 3

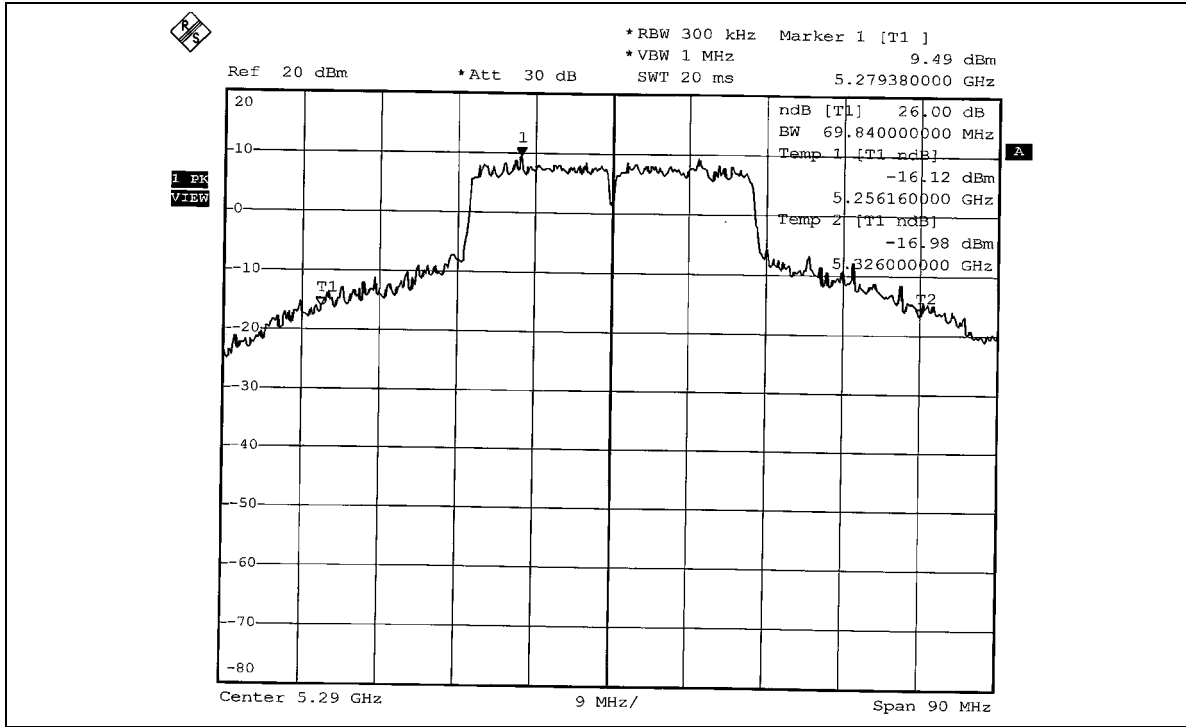



4.4 PEAK POWER EXCURSION MEASUREMENT

4.4.1 LIMITS OF PEAK POWER EXCURSION MEASUREMENT

Frequency Band	Limit
5.15 – 5.25 GHz	13dB
5.25 – 5.35 GHz	13dB
5.725 – 5.825 GHz	13dB

4.4.2 TEST INSTRUMENTS

Description & Manufacturer	Model No.	Serial No.	Calibrated Until
SPECTRUM ANALYZER	FSEK30	100049	Aug. 12, 2005

NOTE: The calibration interval of the above test instruments is 12 months and the calibrations are traceable to NML/ROC and NIST/USA.

4.4.3 TEST PROCEDURE

1. The transmitter output was connected to the spectrum analyzer.
2. Set the spectrum bandwidth span to view the entire spectrum.
3. Using peak detector and Max-hold function for Trace 1 (RB=1MHz, VB=3MHz) and 2 (RB=1MHz, VB=300KHz).
4. The largest difference between Trace 1 and Trace 2 in any 1MHz band on any frequency was recorded.

4.4.4 DEVIATION FROM TEST STANDARD

No deviation

4.4.5 TEST SETUP

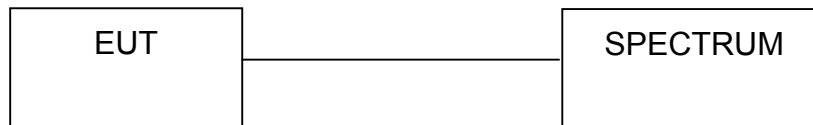

4.4.6 EUT OPERATING CONDITIONS

The software provided by client to enable the EUT under transmission condition continuously at specific channel frequencies individually.



4.4.7 TEST RESULTS

802.11a OFDM modulation

EUT	VA4200 Wi-Fi AP/Bridge	MODEL	VA4200
MODULATION TYPE	BPSK	TRANSFER RATE	6Mbps
INPUT POWER (SYSTEM)	120Vac, 60 Hz	ENVIRONMENTAL CONDITIONS	25deg.C, 63%RH, 991hPa
TESTED BY	Long Chen		

CHANNEL	CHANNEL FREQUENCY (MHz)	PEAK POWER EXCURSION (dB)	PEAK to AVERAGE EXCURSION LIMIT (dB)	PASS/FAIL
1	5180	7.65	13	PASS
4	5240	7.08	13	PASS
5	5260	6.96	13	PASS
8	5320	7.24	13	PASS



CH 1

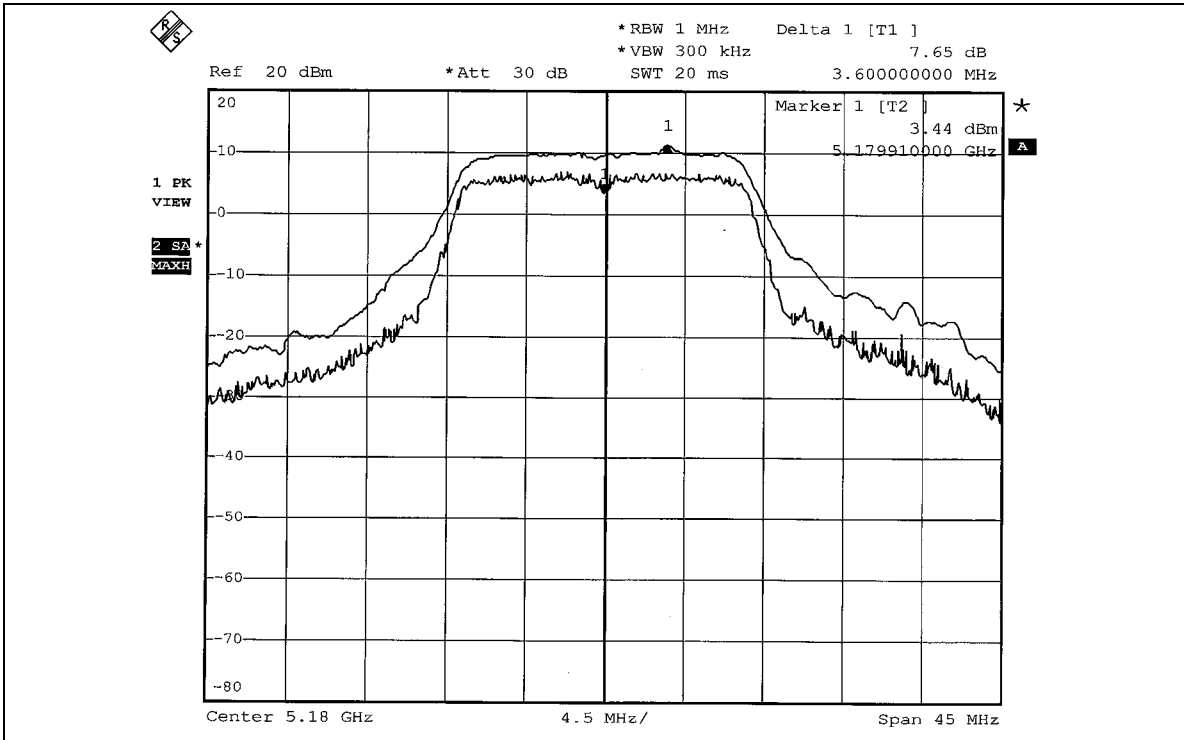

CH 4

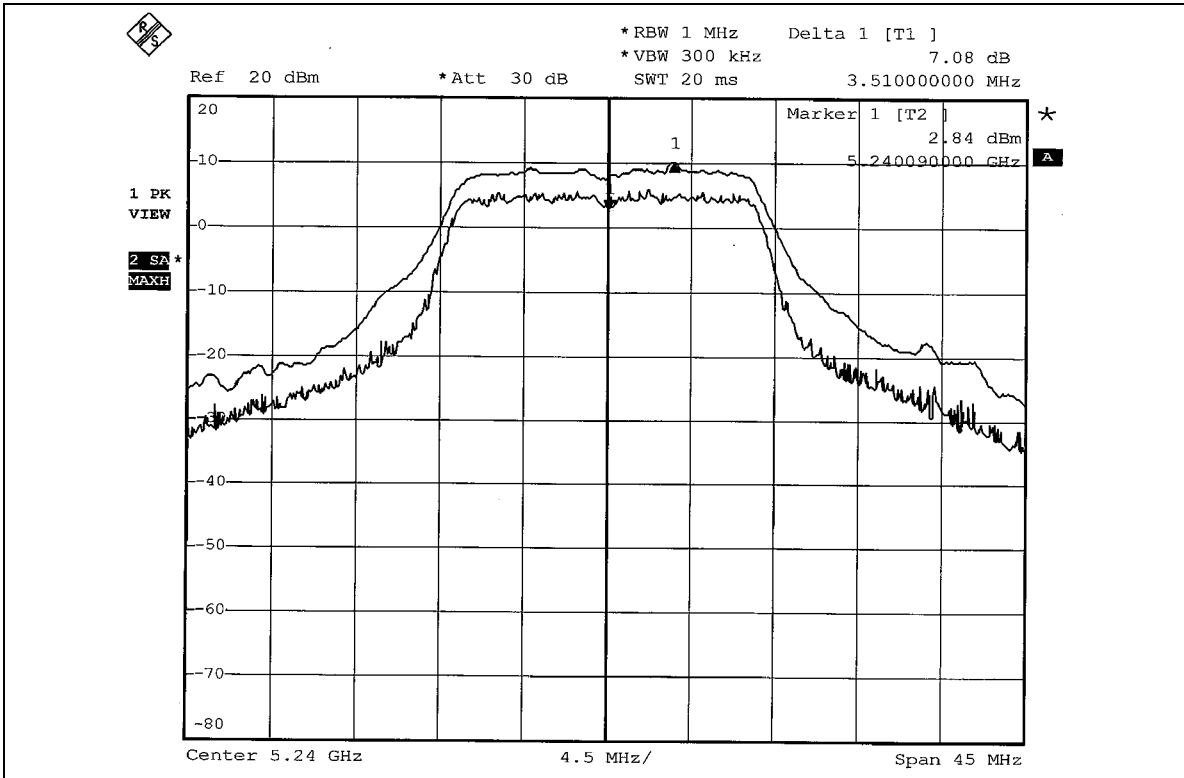



CH 5

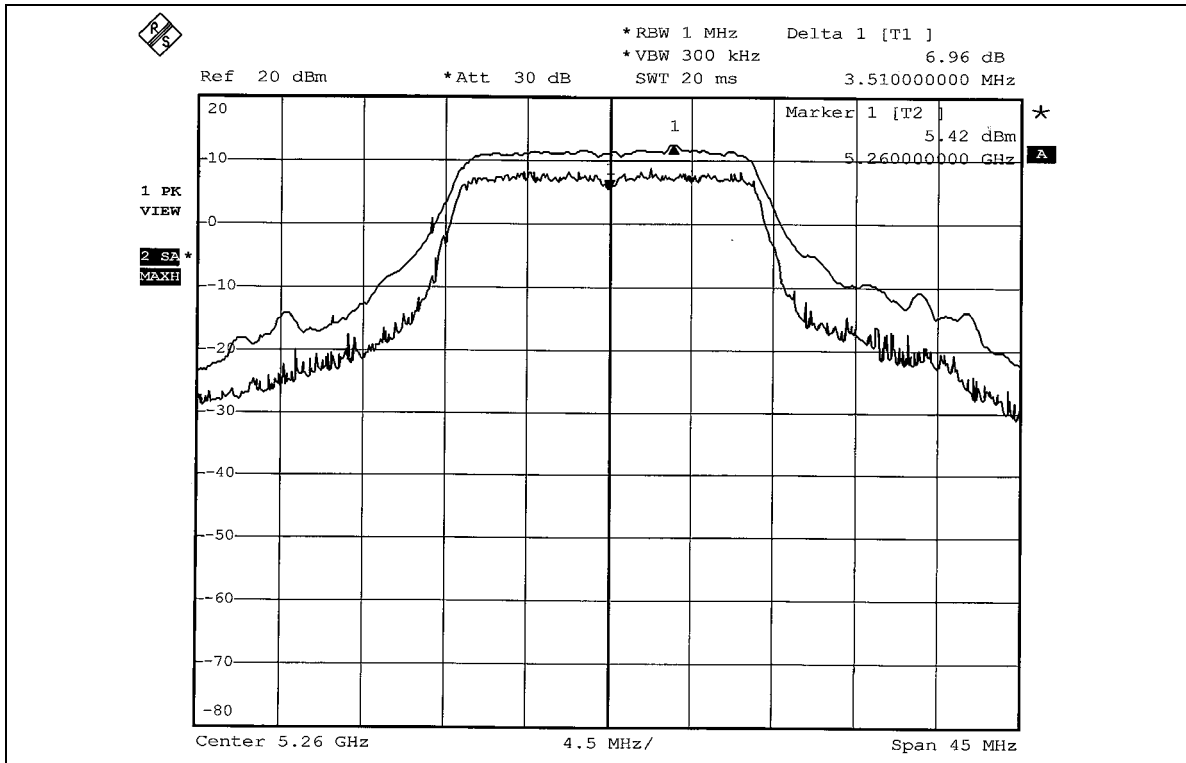

CH 8

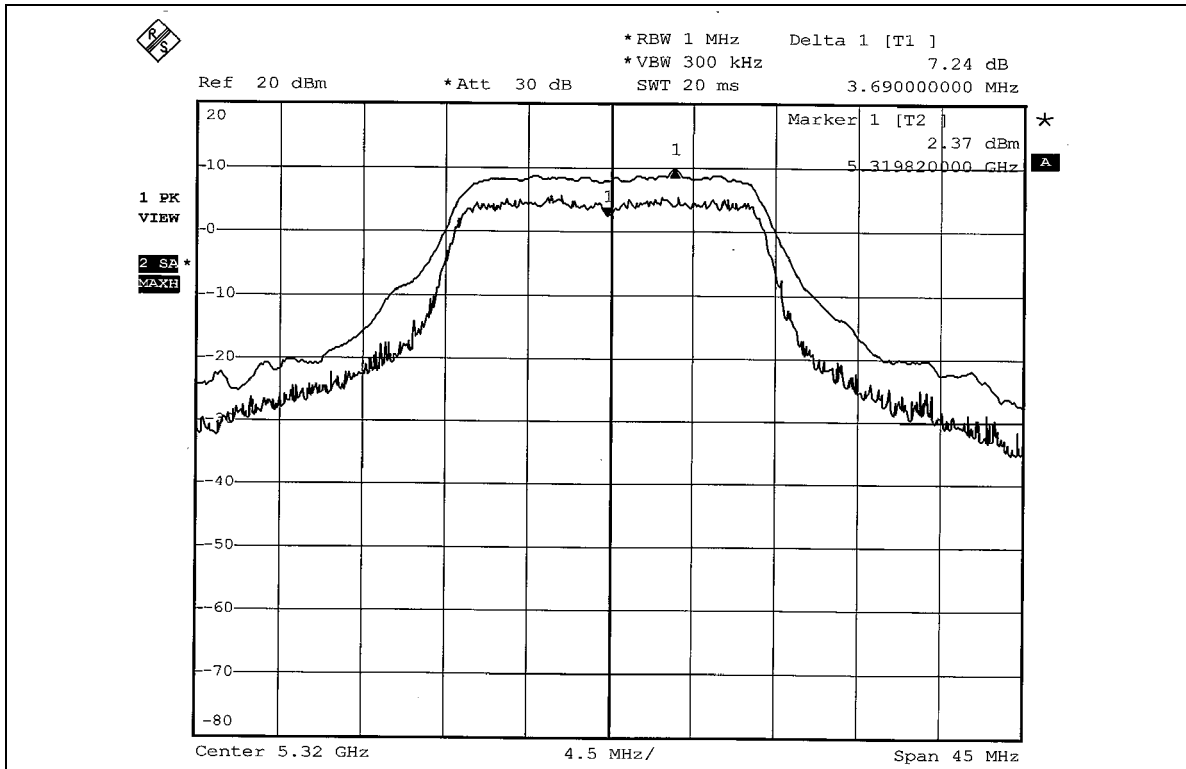

**802.11a Turbo OFDM modulation**

EUT	VA4200 Wi-Fi AP/Bridge	MODEL	VA4200
MODULATION TYPE	BPSK	TRANSFER RATE	6Mbps
INPUT POWER (SYSTEM)	120Vac, 60 Hz	ENVIRONMENTAL CONDITIONS	25deg.C, 63%RH, 991hPa
TESTED BY	Long Chen		

CHANNEL	CHANNEL FREQUENCY (MHz)	PEAK POWER EXCURSION (dB)	PEAK to AVERAGE EXCURSION LIMIT (dB)	PASS/FAIL
1	5210	7.79	13	PASS
2	5250	6.69	13	PASS
3	5290	7.87	13	PASS



CH 1

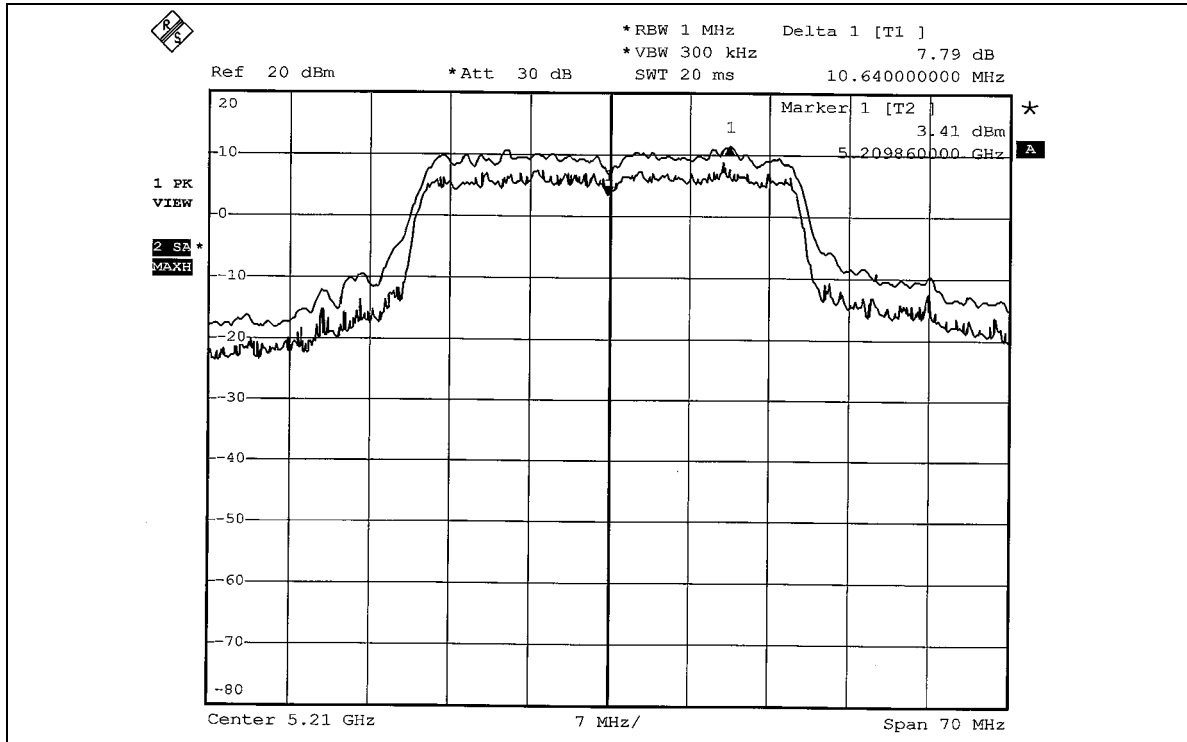

CH 2

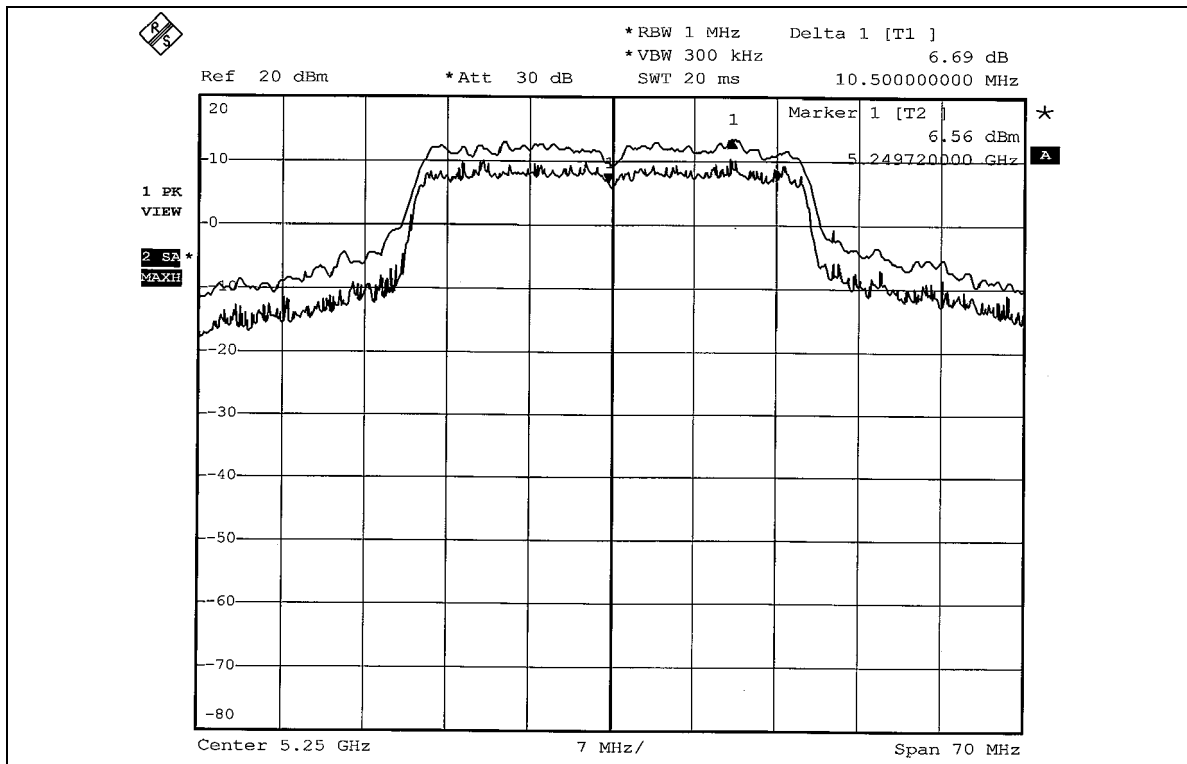



CH 3

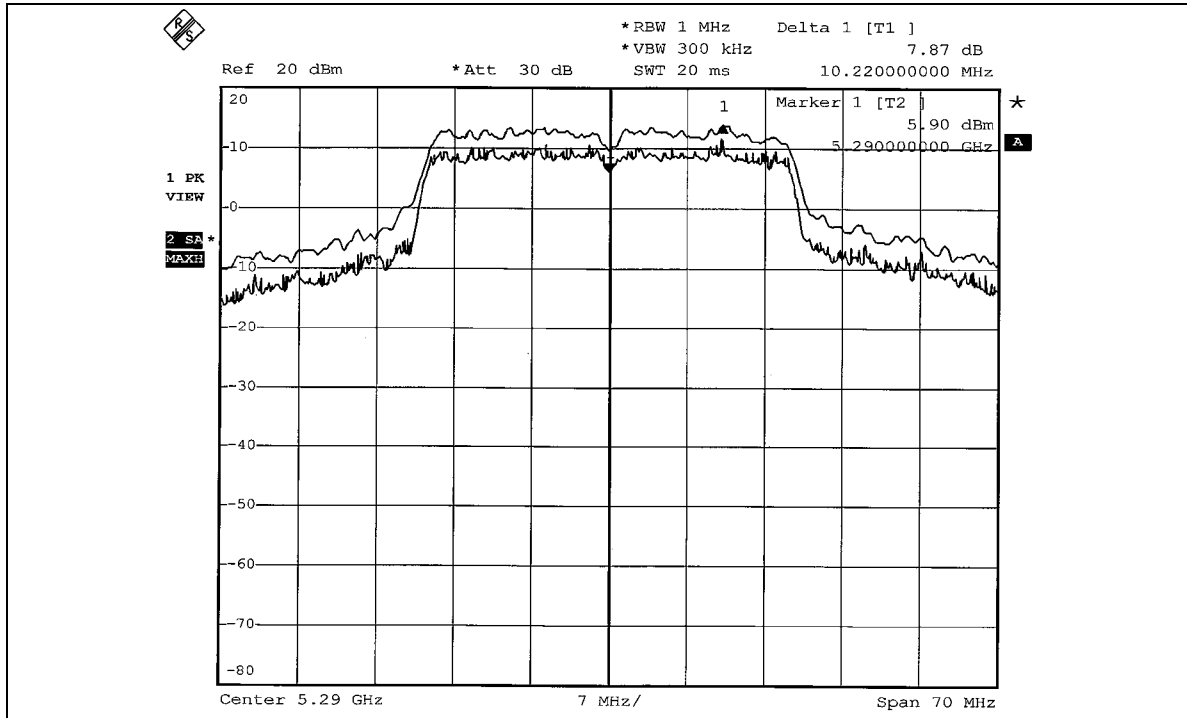



4.5 PEAK POWER SPECTRAL DENSITY MEASUREMENT

4.5.1 LIMITS OF PEAK POWER SPECTRAL DENSITY MEASUREMENT

Frequency Band	Limit
5.15 ~ 5.25GHz	4dBm
5.25 ~ 5.35GHz	11dBm
5.725 ~ 5.825GHz	17dBm

4.5.2 TEST INSTRUMENTS

Description & Manufacturer	Model No.	Serial No.	Calibrated Until
SPECTRUM ANALYZER	FSEK30	100049	Aug. 12, 2005

NOTE: The calibration interval of the above test instruments is 12 months and the calibrations are traceable to NML/ROC and NIST/USA.

4.5.3 TEST PROCEDURES

1. The transmitter output was connected to the spectrum analyzer.
2. Set RBW=1MHz, VBW=3MHz. The PPSD is the highest level found across the emission in any 1MHz band.

4.5.4 DEVIATION FROM TEST STANDARD

No deviation

4.5.5 TEST SETUP

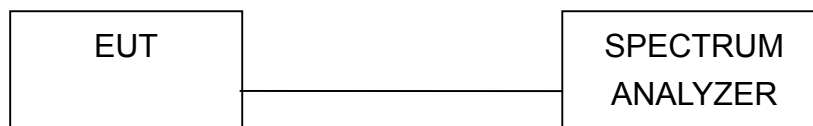

4.5.6 EUT OPERATING CONDITIONS

Same as 5.3.6



4.5.7 TEST RESULTS

802.11a OFDM modulation

EUT	VA4200 Wi-Fi AP/Bridge	MODEL	VA4200
MODULATION TYPE	BPSK	TRANSFER RATE	6Mbps
INPUT POWER (SYSTEM)	120Vac, 60 Hz	ENVIRONMENTAL CONDITIONS	25deg.C, 63%RH, 991hPa
TESTED BY	Long Chen		

CHANNEL	CHANNEL FREQUENCY (MHz)	RF POWER LEVEL IN 1MHz BW (dBm)	MAXIMUM LIMIT (dBm)	PASS/FAIL
1	5180	1.36	4	PASS
4	5240	0.50	4	PASS
5	5260	2.61	11	PASS
8	5320	-0.79	11	PASS



CH 1

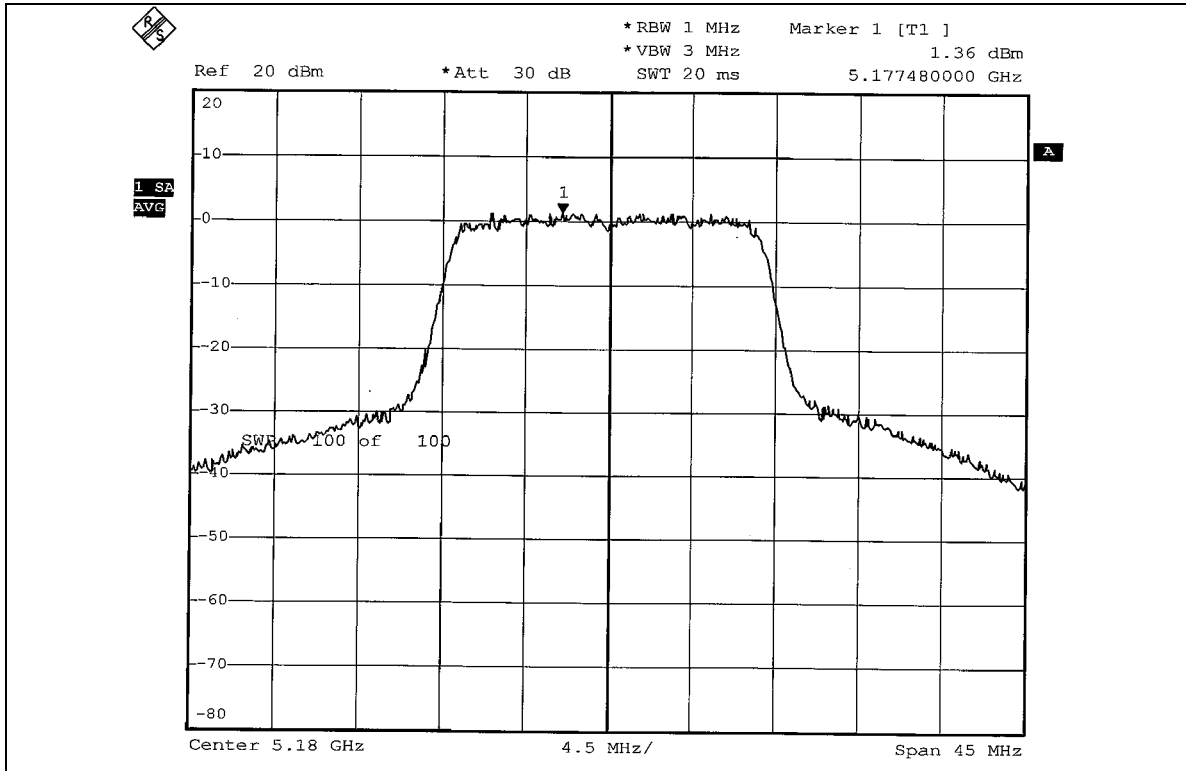

CH 4

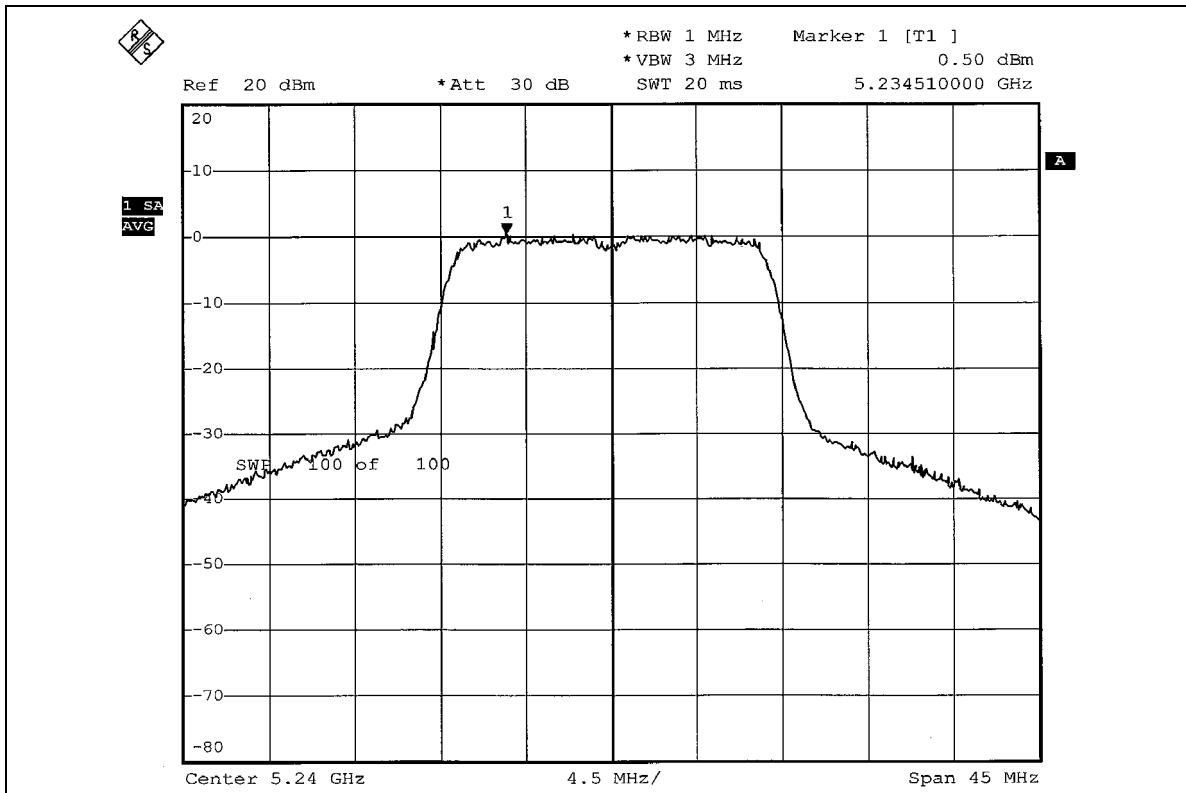



CH 5

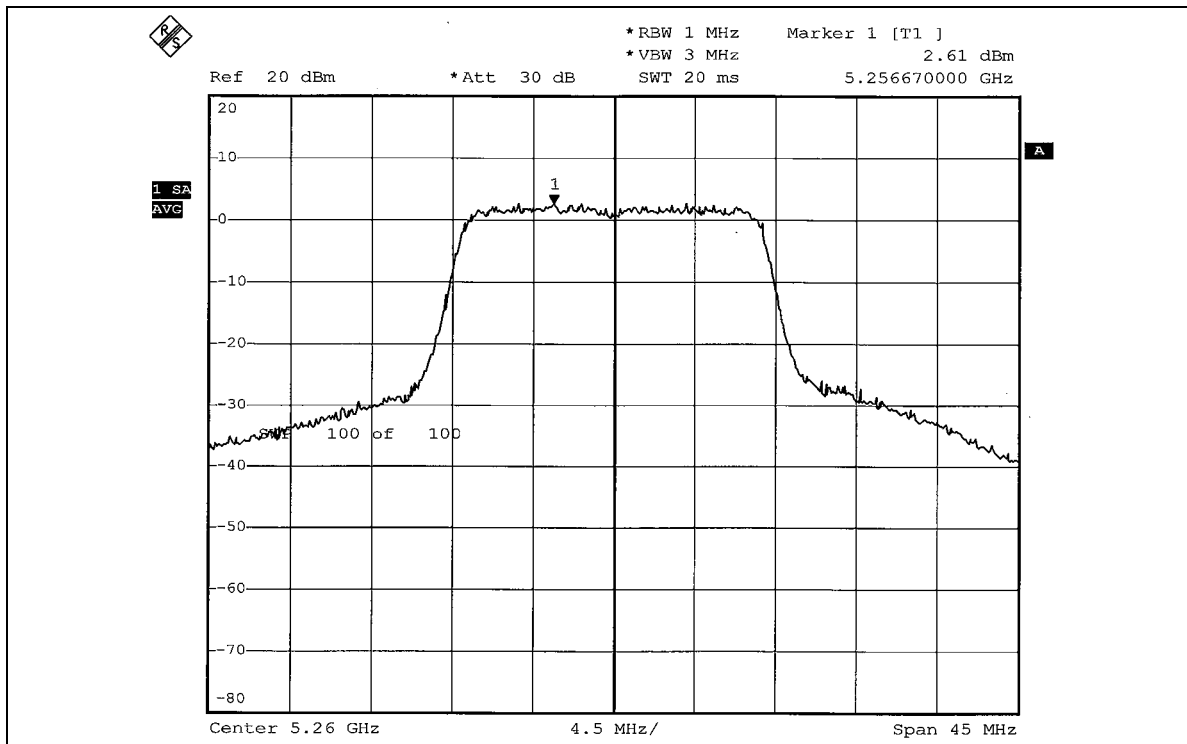

CH 8

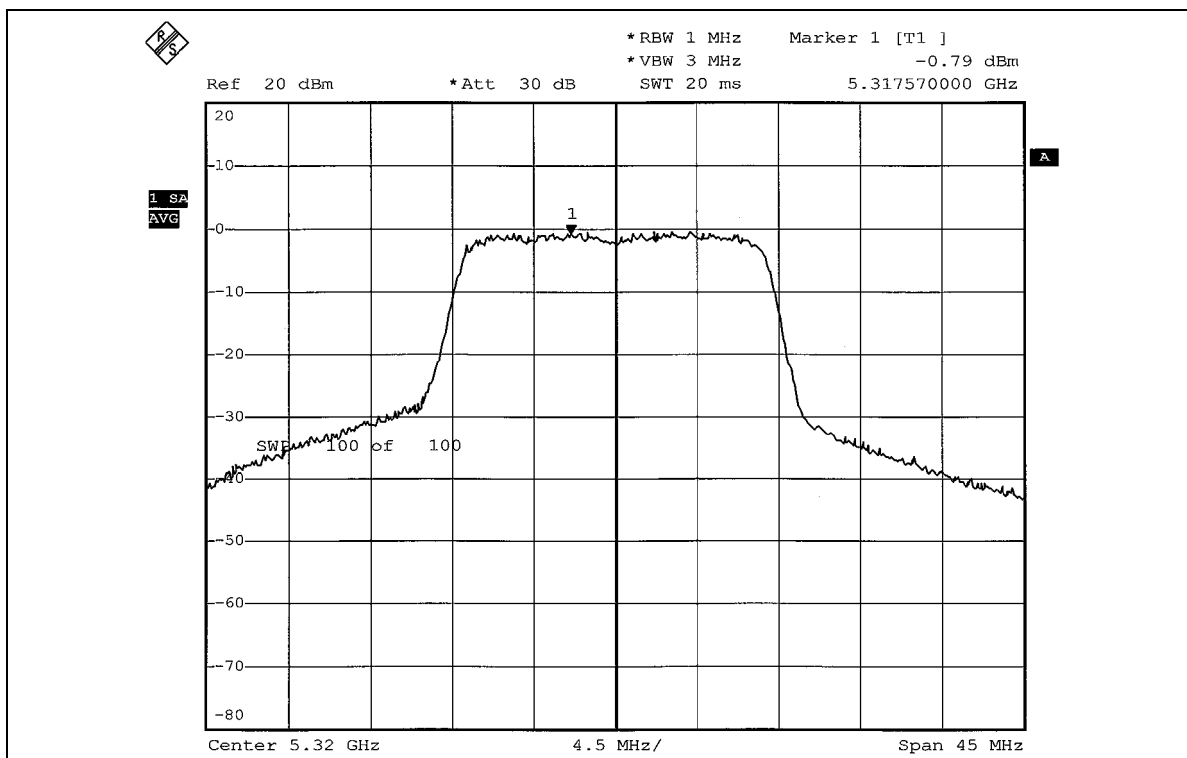



802.11a Turbo OFDM modulation

EUT	VA4200 Wi-Fi AP/Bridge	MODEL	VA4200
MODULATION TYPE	BPSK	TRANSFER RATE	12Mbps
INPUT POWER (SYSTEM)	120Vac, 60 Hz	ENVIRONMENTAL CONDITIONS	25deg.C, 63%RH, 991hPa
TESTED BY	Long Chen		

CHANNEL	CHANNEL FREQUENCY (MHz)	RF POWER LEVEL IN 1 MHz BW (dBm)	MAXIMUM LIMIT (dBm)	PASS/FAIL
1	5210	1.77	4	PASS
2	5250	2.21	11	PASS
3	5290	2.43	11	PASS



CH 1

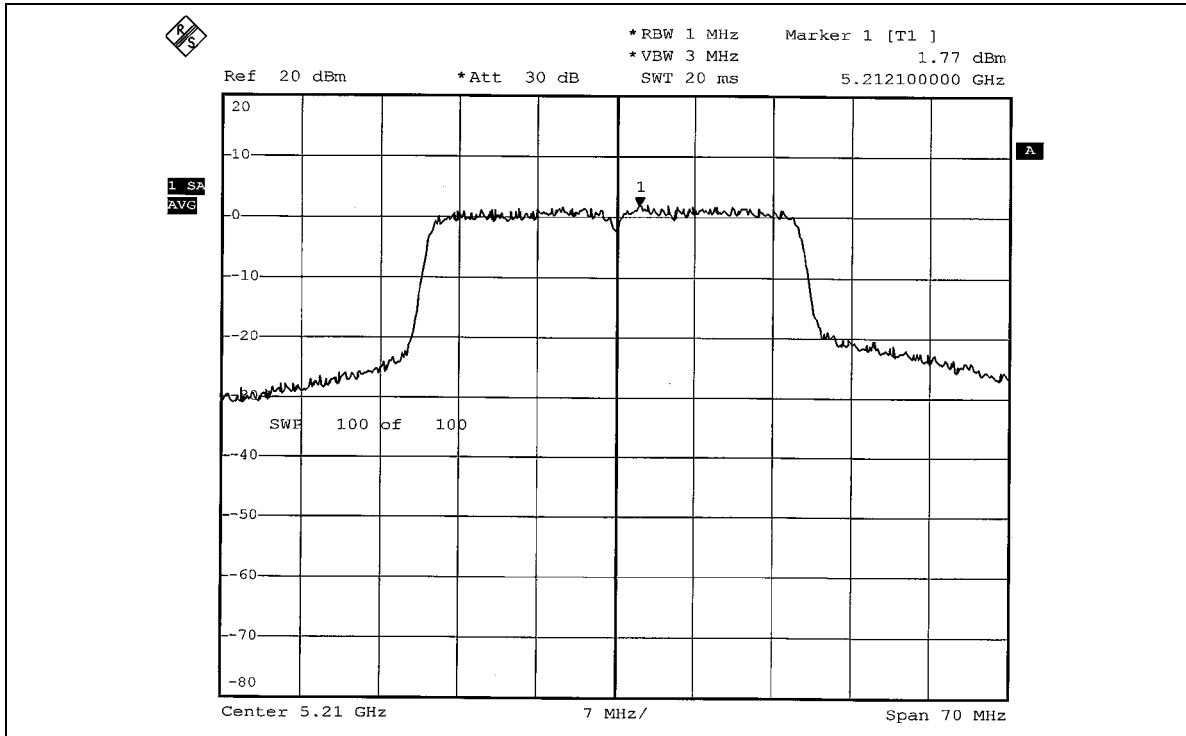

CH 2

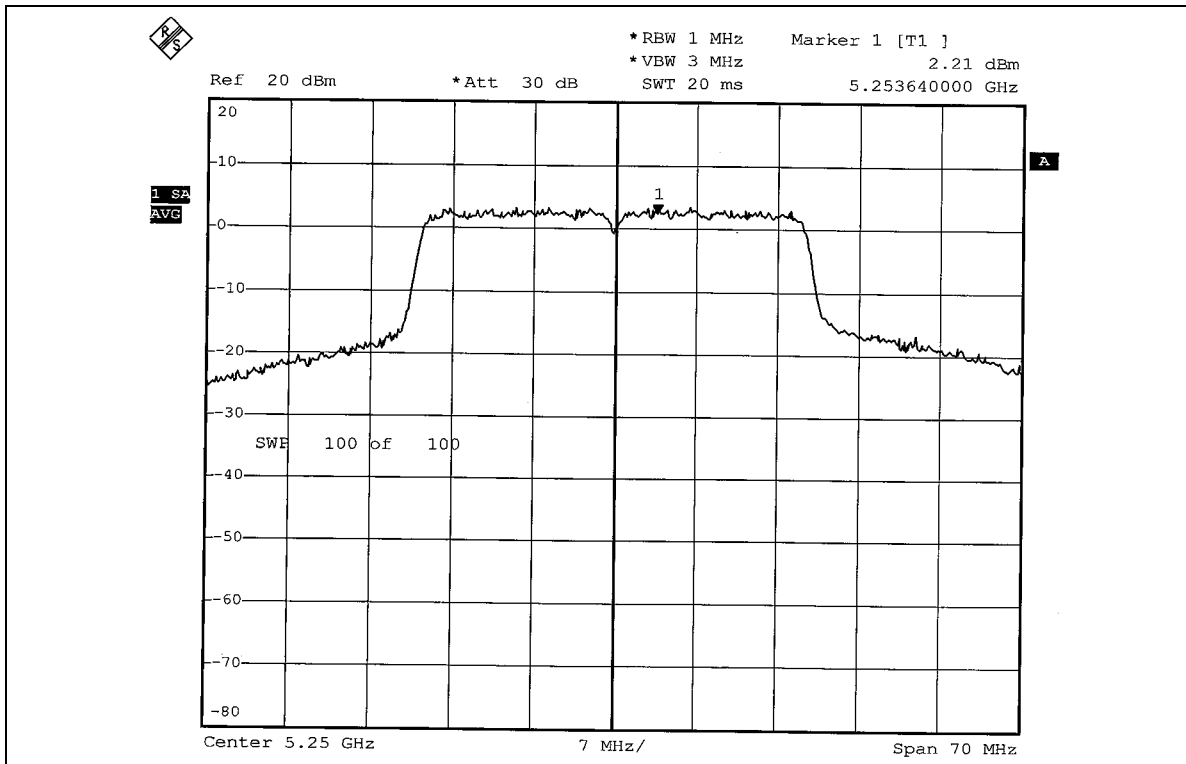



CH 3

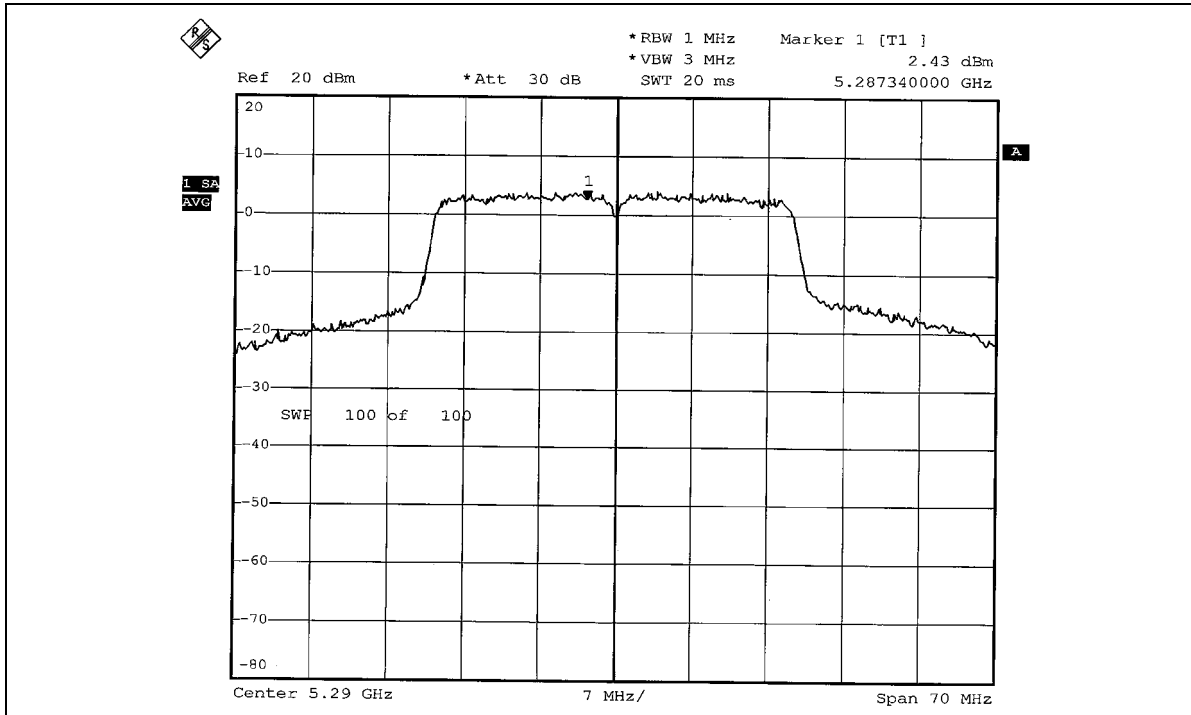



4.6 FREQUENCY STABILITY

4.6.1 LIMITS OF FREQUENCY STABILITY MEASUREMENT

The frequency tolerance of the carrier signal shall be maintained within +/- 0.02% of the operating frequency over a temperature variation of -30 degrees to 50 degrees C at normal supply voltage, and for a variation in the primary supply voltage from 85% to 115% of the rated supply voltage at a temperature of 20 degrees C.

4.6.2 TEST INSTRUMENTS

Description & Manufacturer	Model No.	Serial No.	Calibrated Until
ANRITSU SPECTRUM ANALYZER	MS2667C	M10281	Aug. 12, 2005
WIT STANDARD TEMPERATURE AND HUMIDITY CHAMBER	TH-4S-C	W901030	Aug. 12, 2005

NOTE: The calibration interval of the above test instruments is 12 months and the calibrations are traceable to NML/ROC and NIST/USA.

4.6.3 TEST PROCEDURE

1. The EUT was placed inside the environmental test chamber and powered by nominal DC voltage.
2. Turn the EUT on and couple its output to a spectrum analyzer.
3. Turn the EUT off and set the chamber to the highest temperature specified.
4. Allow sufficient time (approximately 30 min) for the temperature of the chamber to stabilize, turn the EUT on and measure the operating frequency after 2, 5, and 10 minutes.
5. Repeat step 2 and 3 with the temperature chamber set to the lowest temperature.
6. The test chamber was allowed to stabilize at +20 degree C for a minimum of 30 minutes. The supply voltage was then adjusted on the EUT from 85% to 115% and the frequency record.

4.6.4 DEVIATION FROM TEST STANDARD

No deviation

4.6.5 TEST SETUP

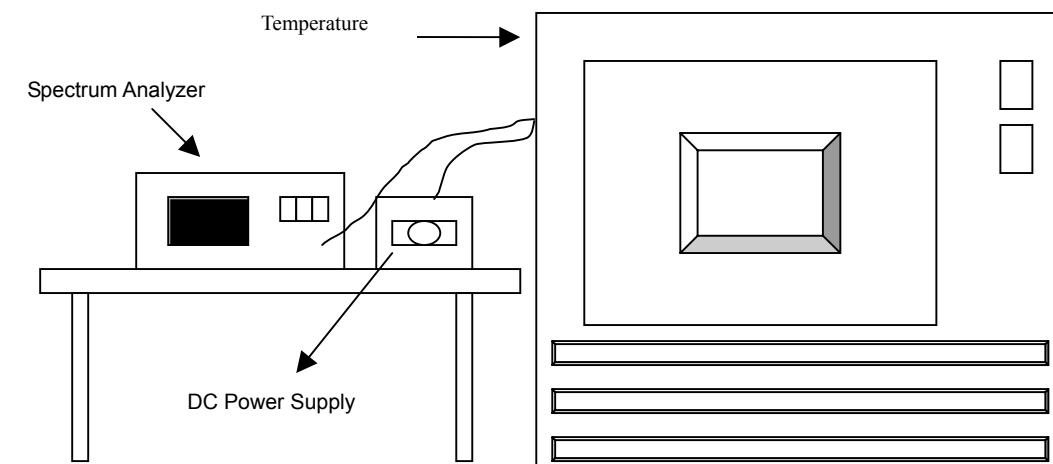

4.6.6 EUT OPERATING CONDITION

Same as Item 4.3.6



4.6.7 TEST RESULTS

		Operating frequency: 5320MHz				Limit : ± 0.015%			
Temp. (°C)	Power supply (Vac)	0 minute		2 minute		5 minute		10 minute	
		(MHz)	(%)	(MHz)	(%)	(MHz)	(%)	(MHz)	(%)
50	138	5319.9692	-0.0005786	5319.9692	-0.0005787	5319.9693	-0.0005779	5319.9692	-0.0005788
	120	5319.9693	-0.0005777	5319.9692	-0.0005783	5319.9692	-0.0005785	5319.9692	-0.0005782
	102	5319.9692	-0.0005789	5319.9692	-0.0005790	5319.9692	-0.0005792	5319.9692	-0.0005786
40	138	5319.9725	-0.0005167	5319.9725	-0.0005166	5319.9726	-0.0005158	5319.9725	-0.0005161
	120	5319.9725	-0.0005163	5319.9725	-0.0005161	5319.9725	-0.0005162	5319.9726	-0.0005156
	102	5319.9725	-0.0005161	5319.9726	-0.0005155	5319.9725	-0.0005161	5319.9725	-0.0005160
30	138	5319.9764	-0.0004439	5319.9764	-0.0004438	5319.9764	-0.0004438	5319.9764	-0.0004444
	120	5319.9764	-0.0004440	5319.9764	-0.0004443	5319.9764	-0.0004439	5319.9763	-0.0004450
	102	5319.9764	-0.0004438	5319.9764	-0.0004445	5319.9764	-0.0004442	5319.9763	-0.0004447
20	138	5319.9791	-0.0003923	5319.9791	-0.0003910	5319.9791	-0.0003927	5319.9791	-0.0003927
	120	5319.9791	-0.0003926	5319.9792	-0.0003927	5319.9791	-0.0003923	5319.9791	-0.0003920
	102	5319.9791	-0.0003921	5319.9791	-0.0003403	5319.9791	-0.0003923	5319.9791	-0.0003922
10	138	5319.9818	-0.0003416	5319.9819	-0.0003409	5319.9818	-0.0003416	5319.9818	-0.0003420
	120	5319.9818	-0.0003415	5319.9819	-0.0003416	5319.9818	-0.0003414	5319.9819	-0.0003407
	102	5319.9818	-0.0003412	5319.9818	-0.0002702	5319.9818	-0.0003412	5319.9818	-0.0003414
0	138	5319.9856	-0.0002702	5319.9856	-0.0002700	5319.9856	-0.0002704	5319.9856	-0.0002701
	120	5319.9857	-0.0002697	5319.9856	-0.0002690	5319.9856	-0.0002703	5319.9856	-0.0002701
	102	5319.9856	-0.0002701	5319.9857	-0.0001986	5319.9857	-0.0002696	5319.9857	-0.0002690
-10	138	5319.9894	-0.0001986	5319.9894	-0.0001989	5319.9895	-0.0001983	5319.9891	-0.0002045
	120	5319.9894	-0.0001989	5319.9894	-0.0001989	5319.9895	-0.0001981	5319.9894	-0.0001986
	102	5319.9894	-0.0001985	5319.9894	0.0004421	5319.9894	-0.0001987	5319.9894	-0.0001989
-20	138	5320.0223	0.0004200	5320.0235	0.0004372	5320.0223	0.0004198	5320.0224	0.0004205
	120	5320.0223	0.0004199	5320.0233	0.0004400	5320.0223	0.0004198	5320.0223	0.0004194
	102	5320.0223	0.0004201	5320.0234	0.0004620	5320.0224	0.0004207	5320.0223	0.0004195
-30	138	5320.0243	0.0004573	5320.0246	0.0004645	5320.0244	0.0004585	5320.0247	0.0004650
	120	5320.0245	0.0004607	5320.0247	0.0004579	5320.0245	0.0004602	5320.0245	0.0004613
	102	5320.0248	0.0004669	5320.0244	0.0004579	5320.0243	0.0004573	5320.0247	0.0004641

4.7 BAND EDGES MEASUREMENT

4.7.1 TEST INSTRUMENTS

Description & Manufacturer	Model No.	Serial No.	Calibrated Until
SPECTRUM ANALYZER	FSEK30	100049	Aug. 12, 2005

NOTE: The calibration interval of the above test instruments is 12 months and the calibrations are traceable to NML/ROC and NIST/USA.

4.7.2 TEST PROCEDURE

The transmitter output was connected to the spectrum analyzer via a low lose cable. Set both RBW and VBW of spectrum analyzer to 1MHz with suitable frequency span including 100 MHz bandwidth from band edge. The band edges was measured and recorded.

4.7.3 EUT OPERATING CONDITION

The software provided by client to enable the EUT under transmission condition continuously at specific channel frequencies individually.

4.7.4 TEST RESULTS

For signals in the restricted bands above and below the 5.15 to 5.35GHz allocated band a measurement was made of the amplitude of the spurious emissions with respect to the intentional signals. The relative amplitude, in dBc, was applied to the average and peak filed strength of the intentional signal made on the OATS to calculate the field strength of the unintentional signals.

The spectrum plots (Peak RBW=VBW=1MHz; Average RBW=1MHz, VBW=10Hz) are attached on the following pages.

**802.11a OFDM modulation**

Channel 1 (5180MHz)

The band edge emission plot on page 70 shows 39.61dBc between carrier maximum power and local maximum emission in restrict band. The emission of carrier strength list in the test result of channel 1 is 107.21dBuV/m (Peak), so the maximum field strength in restrict band is $107.21-39.61=67.60$ dBuV/m which is under 74dBuV/m limit.

The band edge emission plot on page 70 shows 44.93dBc between carrier maximum power and local maximum emission in restrict band. The emission of carrier strength list in the test result of channel 1 is 96.24dBuV/m (Average), so the maximum field strength in restrict band is $96.24-44.93=51.31$ dBuV/m which is under 54dBuV/m limit.

Channel 8 (5320MHz)

The band edge emission plot on page 71 shows 40.05dBc between carrier maximum power and local maximum emission in restrict band. The emission of carrier strength list in the test result of channel 8 is 107.86dBuV/m (Peak), so the maximum field strength in restrict band is $107.86-40.05=67.81$ dBuV/m which is under 74dBuV/m limit.

The band edge emission plot on page 72 shows 47.20dBc between carrier maximum power and local maximum emission in restrict band. The emission of carrier strength list in the test result of channel 8 is 97.83dBuV/m (Average), so the maximum field strength in restrict band is $97.83-47.20=50.63$ dBuV/m which is under 54dBuV/m limit.



802.11a OFDM modulation

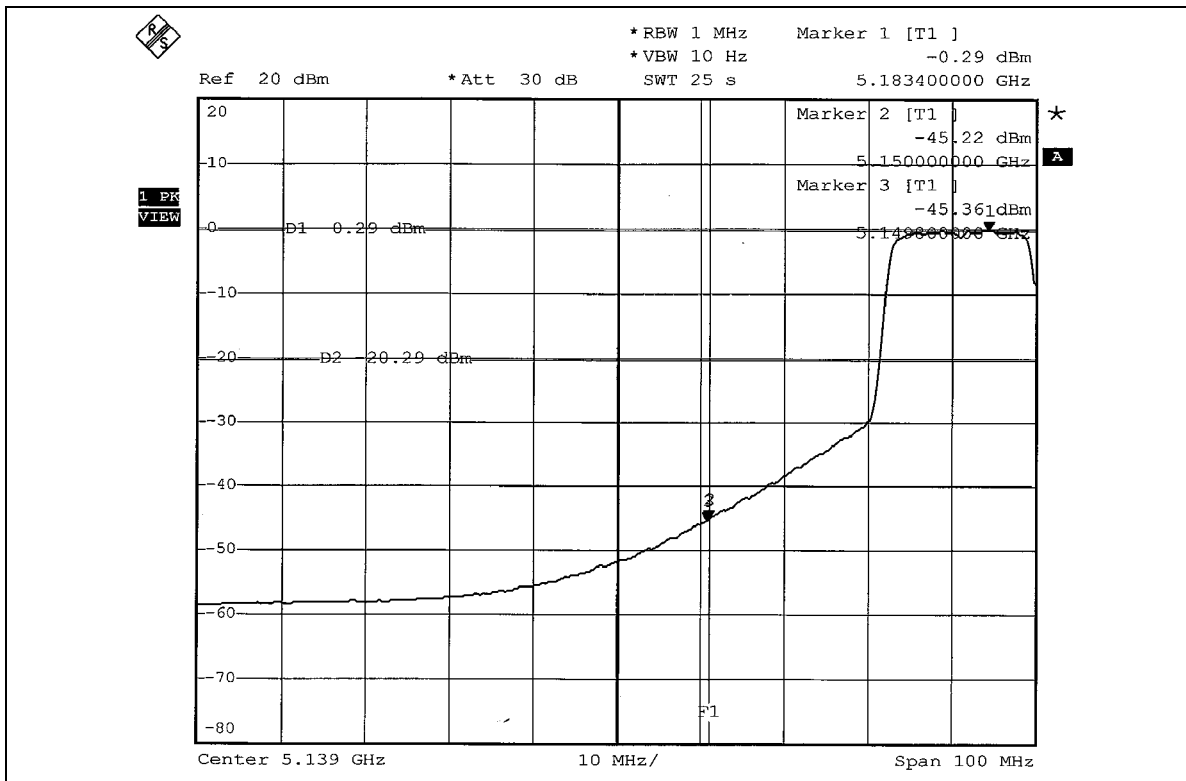
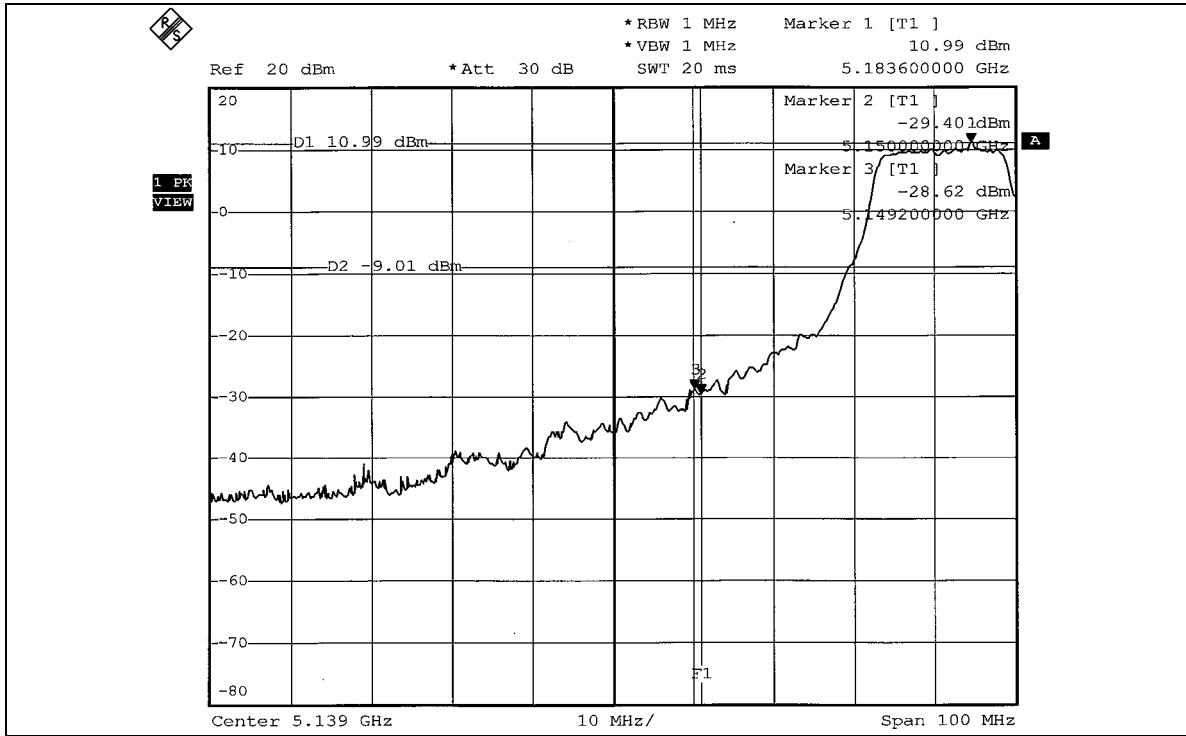

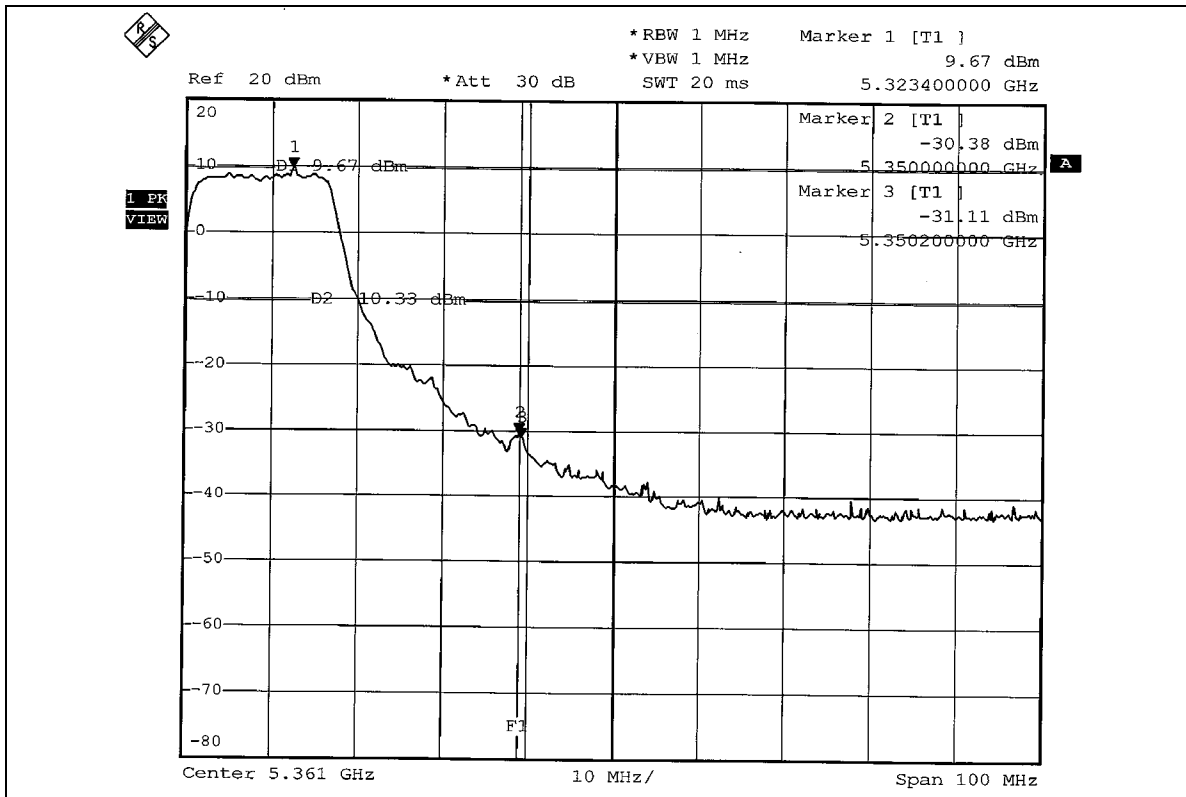
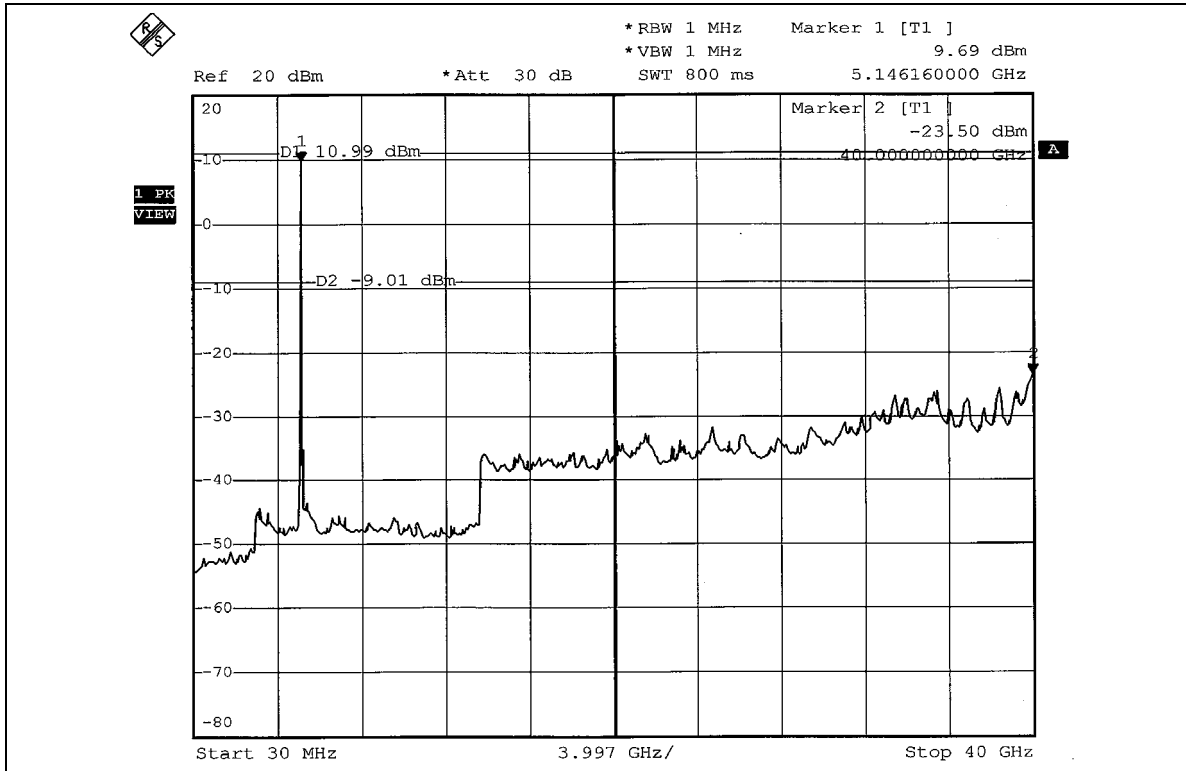

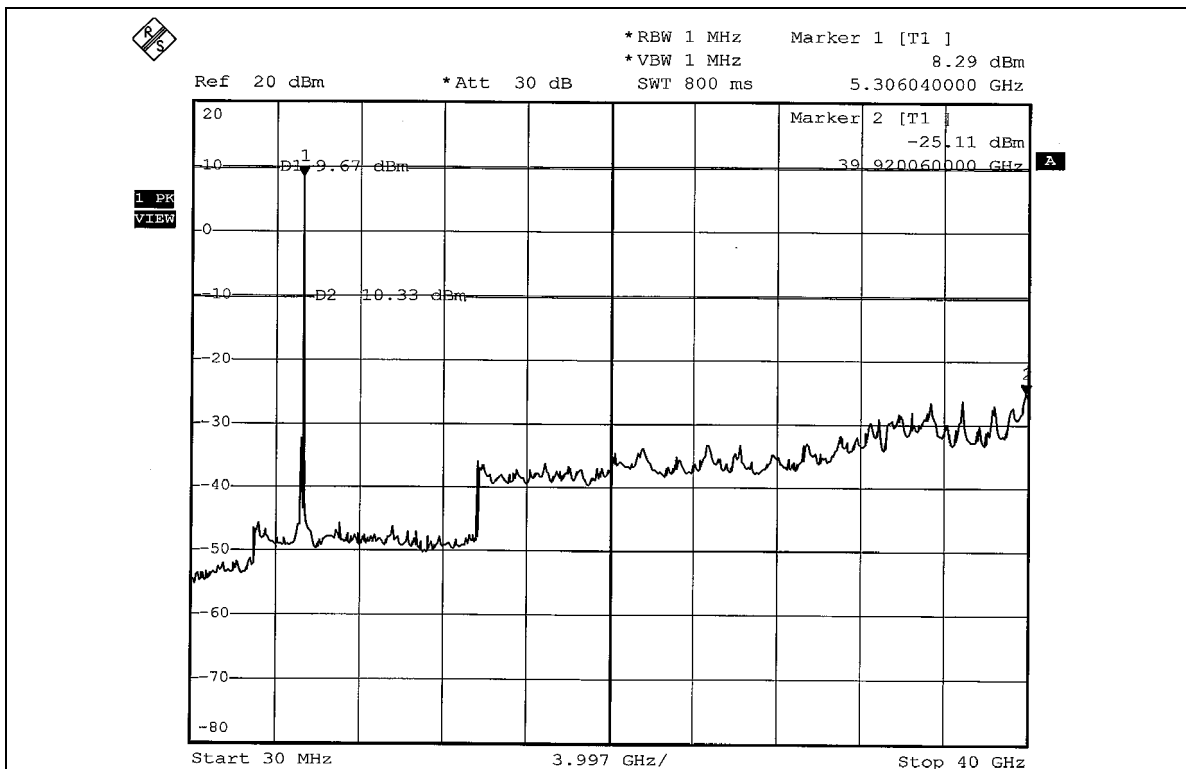
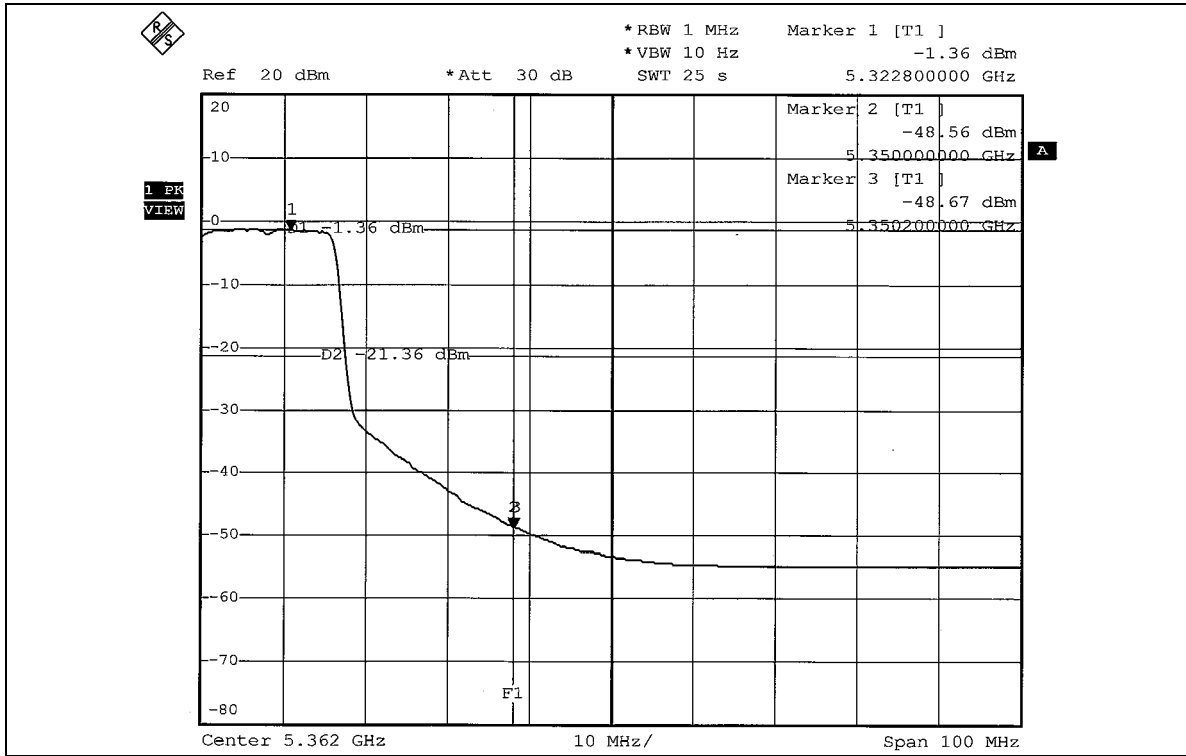

**802.11a Turbo OFDM modulation****Channel 1 (5210MHz)**

The band edge emission plot on page 74 shows 41.93dBc between carrier maximum power and local maximum emission in restrict band. The emission of carrier strength list in the test result of channel 1 is 104.09dBuV/m (Peak), so the maximum field strength in restrict band is $104.09 - 41.93 = 62.16$ dBuV/m which is under 74dBuV/m limit.

The band edge emission plot on page 74 shows 47.30dBc between carrier maximum power and local maximum emission in restrict band. The emission of carrier strength list in the test result of channel 1 is 94.04dBuV/m (Average), so the maximum field strength in restrict band is $94.04 - 47.30 = 46.74$ dBuV/m which is under 54dBuV/m limit.

Channel 3 (5290MHz)

The band edge emission plot on the pages 75 shows 38.66dBc between carrier maximum power and local maximum emission in restrict band. The emission of carrier strength list in the test result of channel 3 is 104.08dBuV/m (Peak), so the maximum field strength in restrict band is $104.08 - 38.66 = 65.42$ dBuV/m which is under 74dBuV/m limit.

The band edge emission plot on the pages 76 shows 44.04dBc between carrier maximum power and local maximum emission in restrict band. The emission of carrier strength list in the test result of channel 3 is 94.02dBuV/m (Average), so the maximum field strength in restrict band is $94.02 - 44.04 = 49.98$ dBuV/m which is under 54dBuV/m limit.



802.11a Turbo OFDM modulation

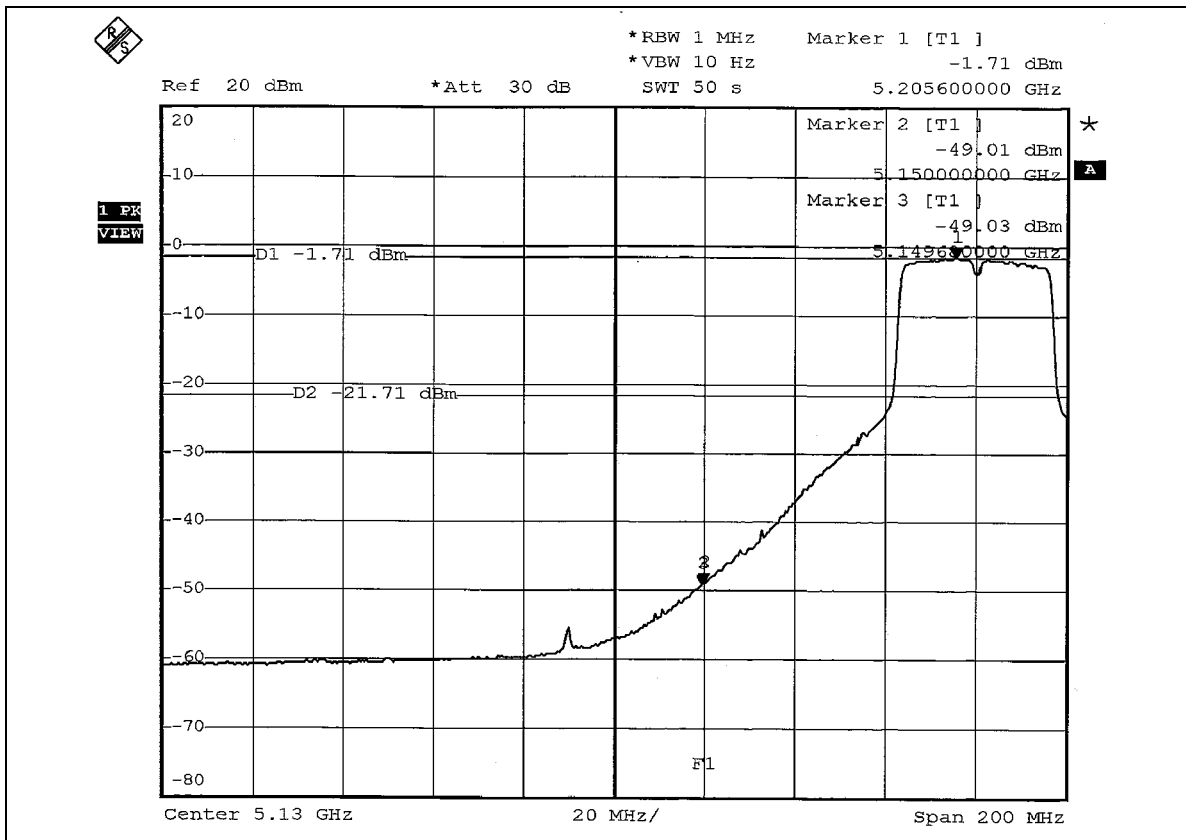
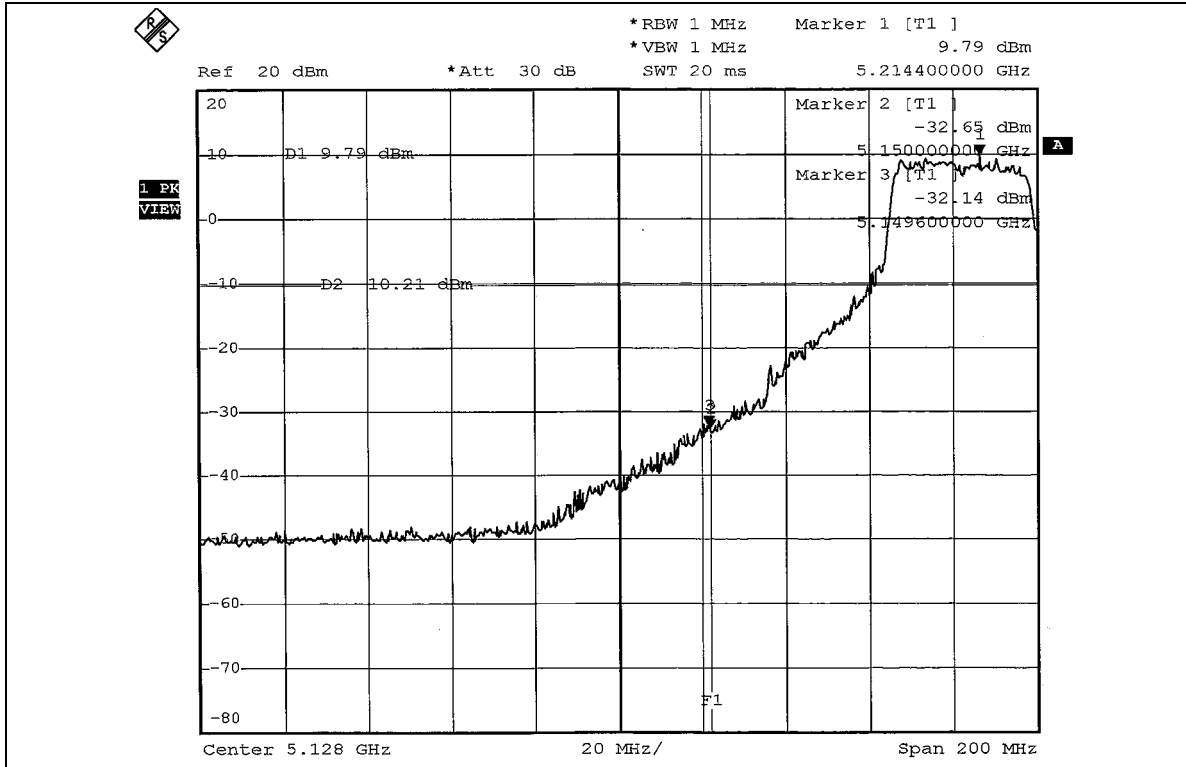

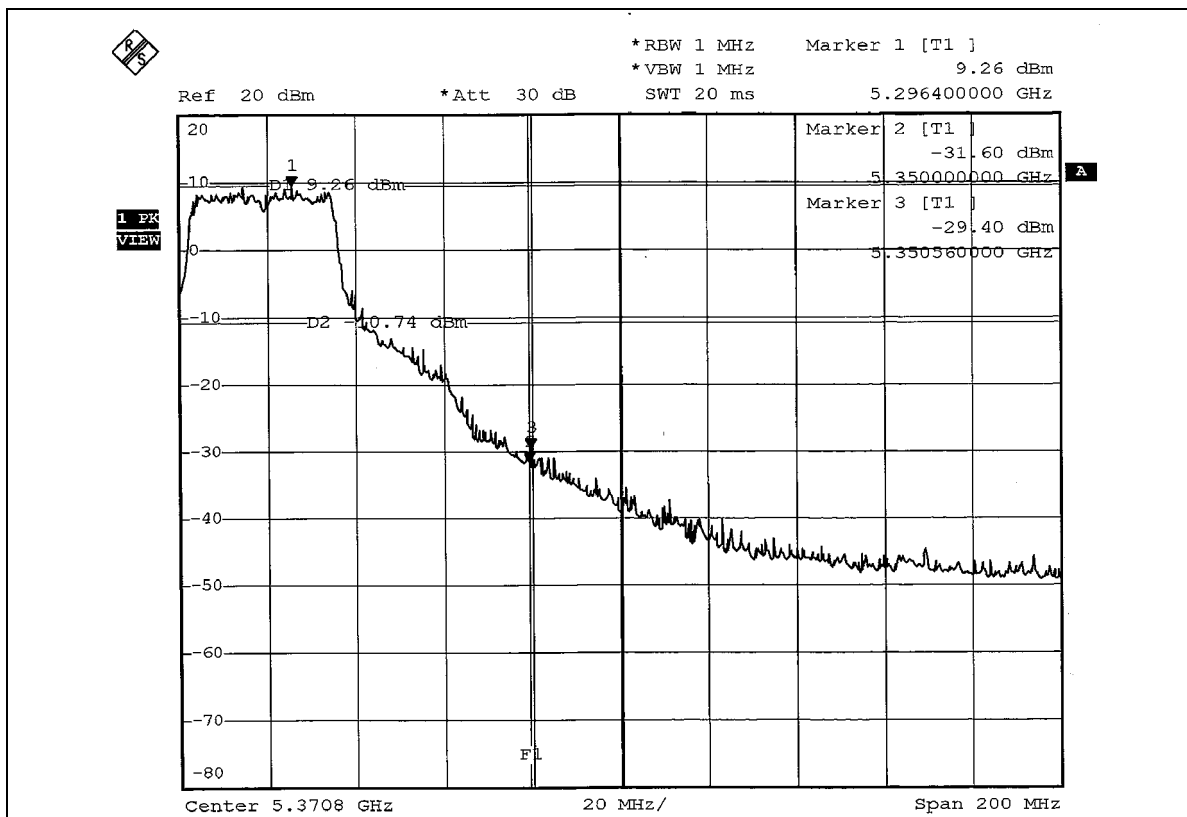
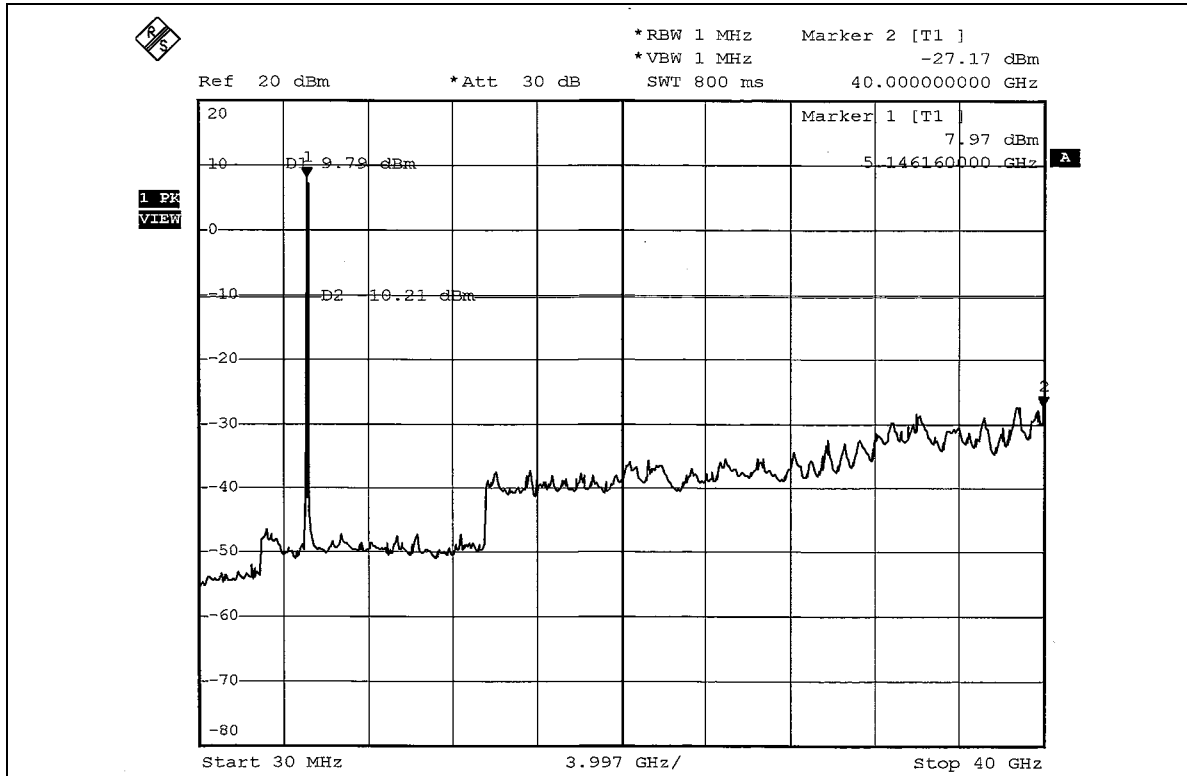

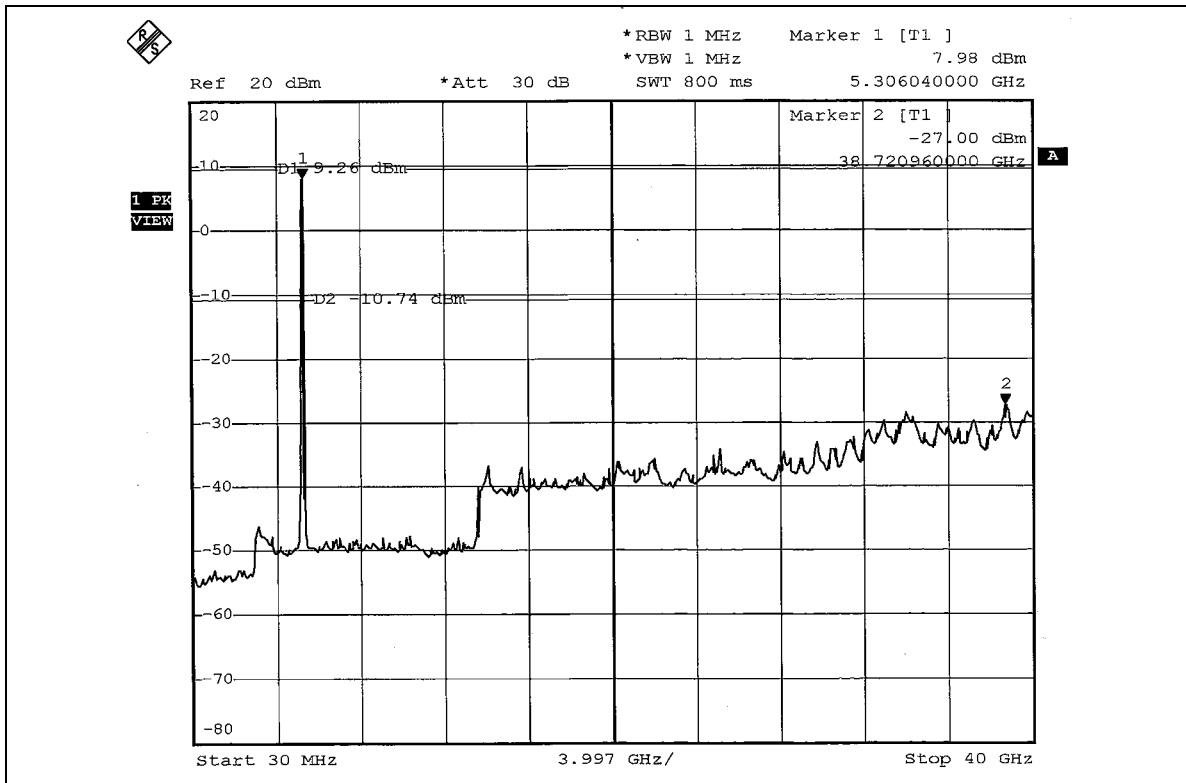
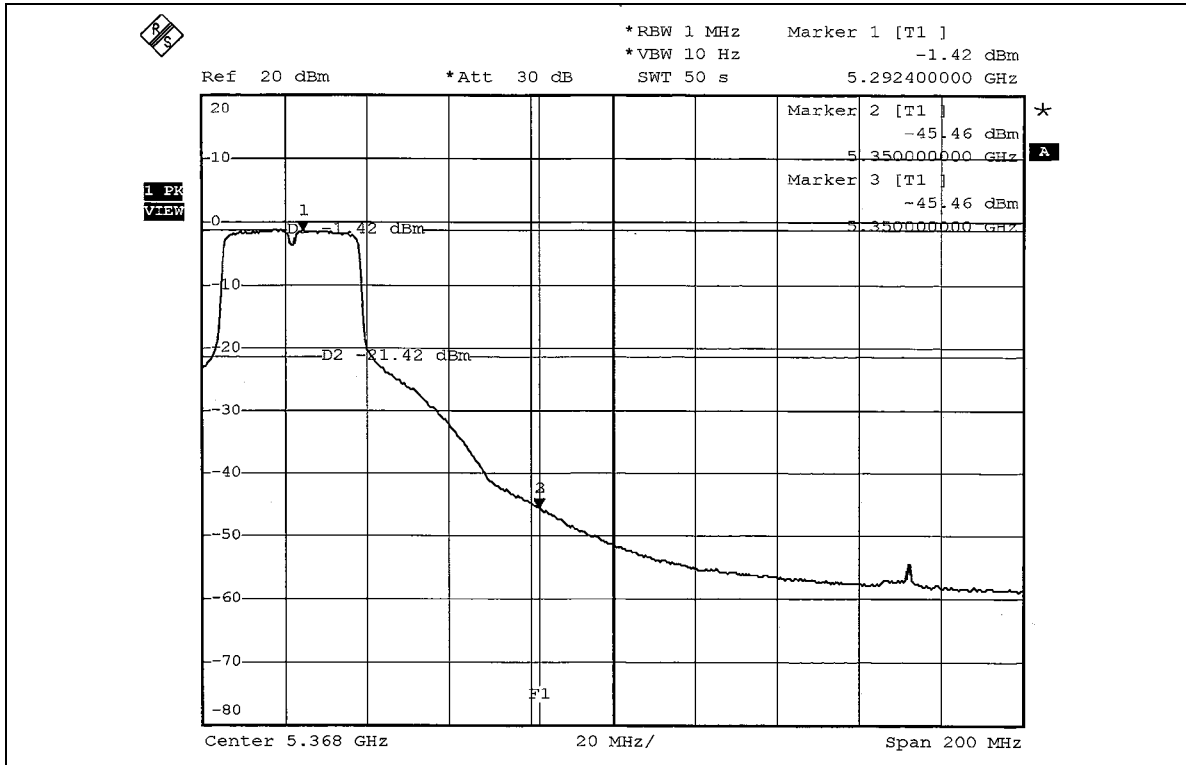



4.8 ANTENNA REQUIREMENT

4.8.1 STANDARD APPLICABLE

For intentional device, according to FCC 47 CFR Section 15.203, an intentional radiator shall be designed to ensure that no antenna other than that furnished by the responsible party shall be used with the device.

And according to FCC 47 CFR Section 15.407(a), if transmitting antennas of directional gain greater than 6dBi are used, the power shall be reduced by the amount in dB that the directional gain of the antenna exceeds 6dBi.

4.8.2 ANTENNA CONNECTED CONSTRUCTION

The antenna used in this product is Dipole antenna with Reverse-TNC connector. The maximum Gain of the antenna is 2dBi.

5. PHOTOGRAPHS OF THE TEST CONFIGURATION

CONDUCTED EMISSION TEST

Test Mode 1



Test Mode 2



Test Mode 3



RADIATED EMISSION TEST

Test Mode 1

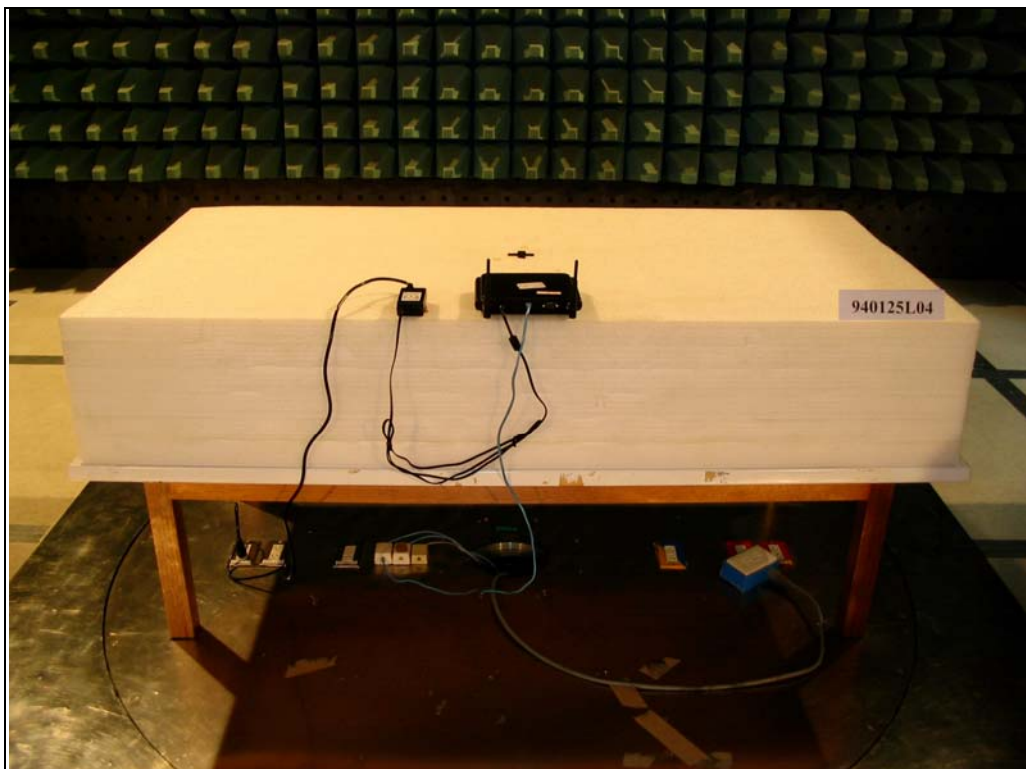

Test Mode 2

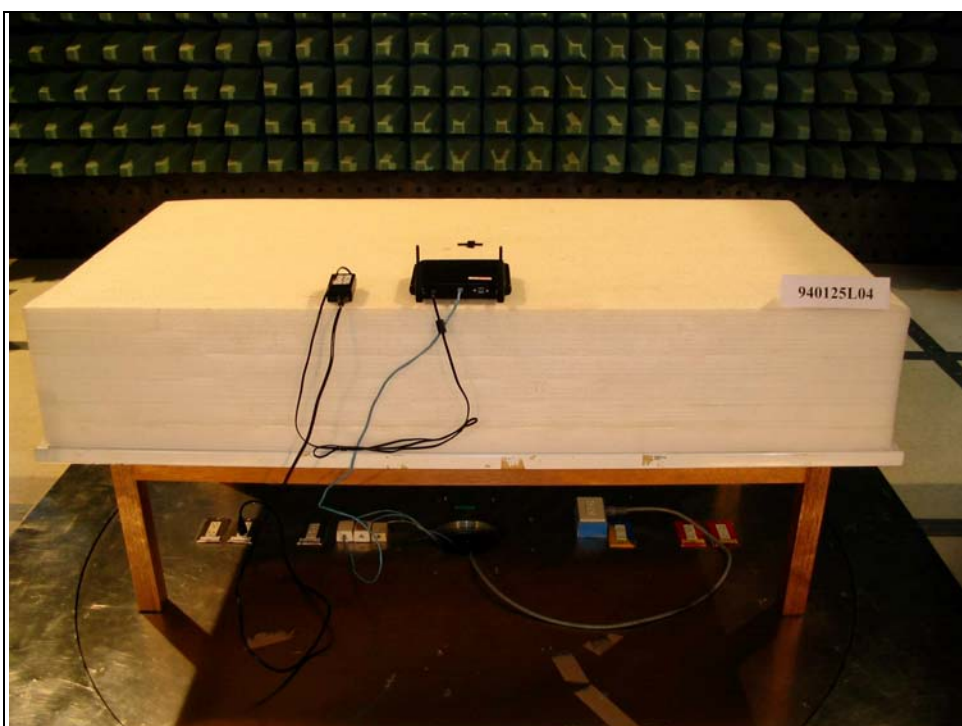

Test Mode 3

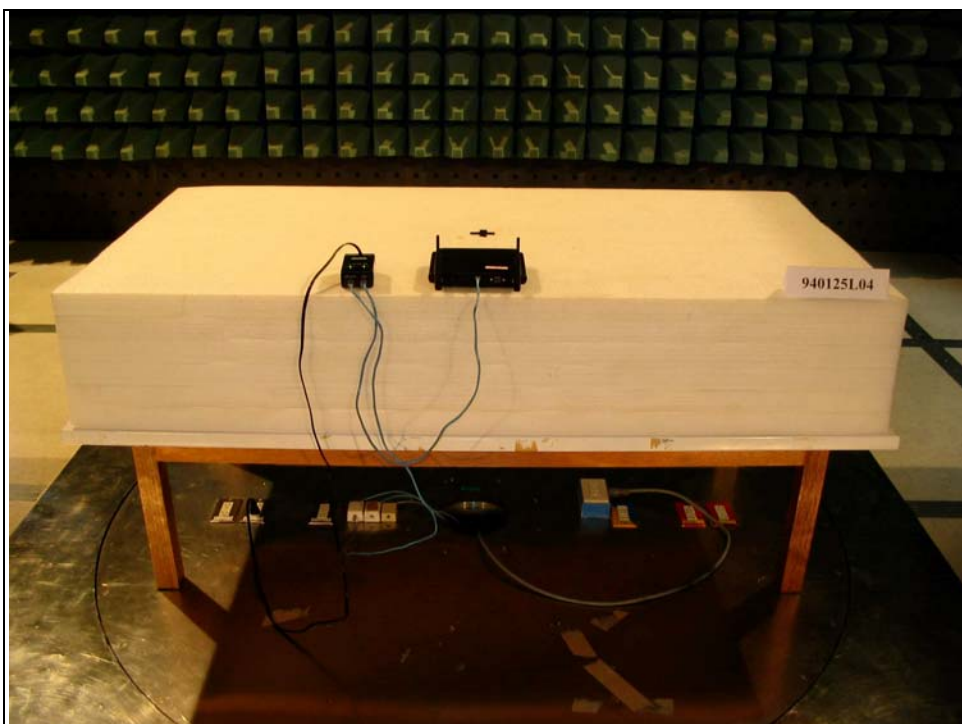
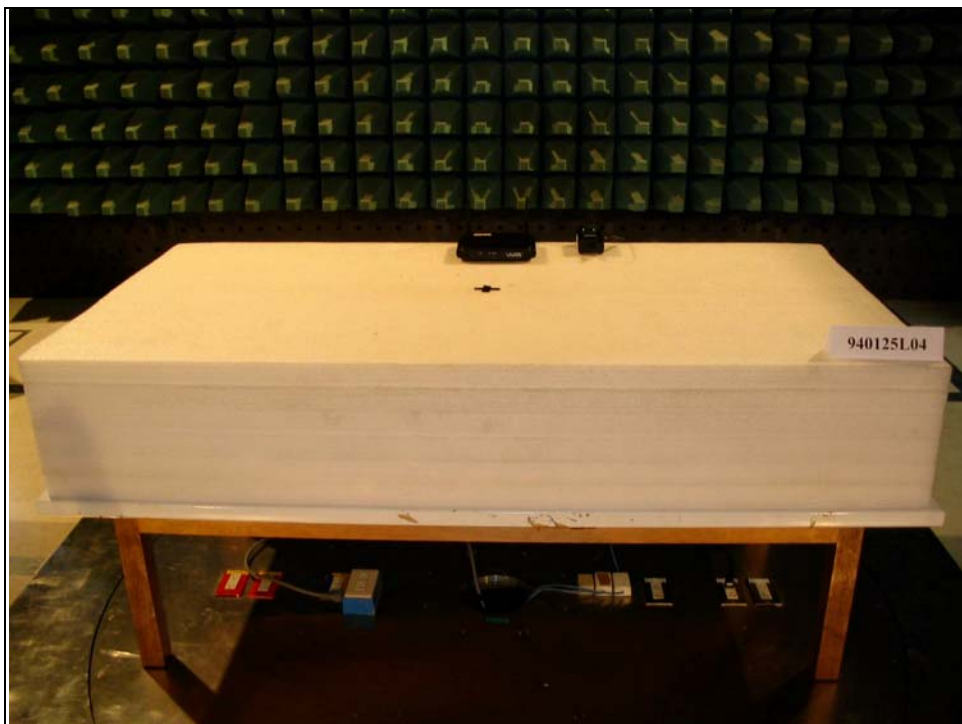



6. INFORMATION ON THE TESTING LABORATORIES

We, ADT Corp., were founded in 1988 to provide our best service in EMC, Radio, Telecom and Safety consultation. Our laboratories are accredited and approved by the following approval agencies according to ISO/IEC 17025:

USA	FCC, NVLAP, UL, A2LA
Germany	TUV Rheinland
Japan	VCCI
Norway	NEMKO
Canada	INDUSTRY CANADA , CSA
R.O.C.	CNLA, BSMI, DGT
Netherlands	Telefication
Singapore	PSB , GOST-ASIA(MOU)
Russia	CERTIS(MOU)

Copies of accreditation certificates of our laboratories obtained from approval agencies can be downloaded from our web site:

www.adt.com.tw/index.5/phtml. If you have any comments, please feel free to contact us at the following:

Linko EMC/RF Lab:

Tel: 886-2-26052180

Fax: 886-2-26052943

Hsin Chu EMC/RF Lab:

Tel: 886-3-5935343

Fax: 886-3-5935342

Hwa Ya EMC/RF/Safety Telecom Lab:

Tel: 886-3-3183232

Fax: 886-3-3185050

Linko RF Lab.

Tel: 886-3-3270910

Fax: 886-3-3270892

Web Site: www.adt.com.tw

The address and road map of all our labs can be found in our web site also