



## FCC TEST REPORT (15.247)

**REPORT NO.:** RF940125L04  
**MODEL NO.:** VA4200  
**RECEIVED:** Apr. 02, 2005  
**TESTED:** Apr. 02 ~ Jul. 04, 2005  
**ISSUED:** Jul. 04, 2005

**APPLICANT:** Vivato, Inc.

**ADDRESS:** 12610 E Mirabeau Pkwy Suite 900

**ISSUED BY:** Advance Data Technology Corporation

**LAB ADDRESS:** No. 47, 14<sup>th</sup> Ling, Chia Pau Tsuen, Lin Kou Hsiang 244, Taipei Hsien, Taiwan, R.O.C.

**TEST LOCATION:** No. 19, Hwa Ya 2<sup>nd</sup> Rd., Wen Hwa Tsuen, Kwei Shan Hsiang, Taoyuan Hsien 333, Taiwan, R.O.C.

This test report consists of 123 pages in total. It may be duplicated completely for legal use with the approval of the applicant. It should not be reproduced except in full, without the written approval of our laboratory. The client should not use it to claim product endorsement by CNLA, A2LA or any government agencies. The test results in the report only apply to the tested sample.



0528  
ILAC MRA



No. 2177-01



## Table of Contents

1.	CERTIFICATION .....	5
2.	SUMMARY OF TEST RESULTS .....	6
2.1	MEASUREMENT UNCERTAINTY .....	6
3.	GENERAL INFORMATION.....	7
3.1	GENERAL DESCRIPTION OF EUT.....	7
3.2	DESCRIPTION OF TEST MODES.....	9
3.2.1	CONFIGURATION OF SYSTEM UNDER TEST .....	10
3.2.2	TEST MODE APPLICABILITY AND TESTED CHANNEL DETAIL:.....	11
3.3	GENERAL DESCRIPTION OF APPLIED STANDARDS .....	13
3.4	DESCRIPTION OF SUPPORT UNITS .....	13
4.	TEST TYPES AND RESULTS (802.11b & g 2412~2462MHz BAND) .....	13
4.1	CONDUCTED EMISSION MEASUREMENT .....	14
4.1.1	LIMITS OF CONDUCTED EMISSION MEASUREMENT.....	14
4.1.2	TEST INSTRUMENTS.....	14
4.1.3	TEST PROCEDURES .....	15
4.1.4	DEVIATION FROM TEST STANDARD .....	15
4.1.5	TEST SETUP .....	16
4.1.6	EUT OPERATING CONDITIONS .....	16
4.1.7	TEST RESULTS .....	17
4.2	RADIATED EMISSION MEASUREMENT .....	35
4.2.1	LIMITS OF RADIATED EMISSION MEASUREMENT.....	35
4.2.2	TEST INSTRUMENTS.....	36
4.2.3	TEST PROCEDURES .....	37
4.2.4	DEVIATION FROM TEST STANDARD .....	37
4.2.5	TEST SETUP .....	38
4.2.6	EUT OPERATING CONDITIONS .....	38
4.2.7	TEST RESULTS .....	39
4.3	6dB BANDWIDTH MEASUREMENT .....	50
4.3.1	LIMITS OF 6dB BANDWIDTH MEASUREMENT .....	50
4.3.2	TEST INSTRUMENTS.....	50
4.3.3	TEST PROCEDURE.....	51
4.3.4	DEVIATION FROM TEST STANDARD .....	51
4.3.5	TEST SETUP .....	51
4.3.6	EUT OPERATING CONDITIONS .....	51
4.3.7	TEST RESULTS .....	52
4.4	MAXIMUM PEAK OUTPUT POWER .....	58
4.4.1	LIMITS OF MAXIMUM PEAK OUTPUT POWER MEASUREMENT.....	58
4.4.2	INSTRUMENTS.....	58
4.4.1	TEST PROCEDURES .....	59
4.4.2	DEVIATION FROM TEST STANDARD .....	59
4.4.3	TEST SETUP .....	59
4.4.4	EUT OPERATING CONDITIONS .....	59
4.4.3	TEST RESULTS .....	60
4.5	POWER SPECTRAL DENSITY MEASUREMENT.....	61
4.5.1	LIMITS OF POWER SPECTRAL DENSITY MEASUREMENT .....	61
4.5.2	TEST INSTRUMENTS.....	61
4.5.3	TEST PROCEDURE.....	62



4.5.4	DEVIATION FROM TEST STANDARD .....	62
4.5.5	TEST SETUP .....	62
4.5.6	EUT OPERATING CONDITION .....	62
4.5.7	TEST RESULTS .....	63
4.6	BAND EDGES MEASUREMENT .....	69
4.6.1	LIMITS OF BAND EDGES MEASUREMENT .....	69
4.6.2	TEST INSTRUMENTS.....	69
4.6.3	TEST PROCEDURE.....	69
4.6.4	DEVIATION FROM TEST STANDARD .....	69
4.6.5	EUT OPERATING CONDITION .....	69
4.6.6	TEST RESULTS .....	70
4.7	ANTENNA REQUIREMENT .....	78
4.7.1	STANDARD APPLICABLE .....	78
4.7.2	ANTENNA CONNECTED CONSTRUCTION.....	78
5.	TEST TYPES AND RESULTS (802.11a 5725~5850MHz BAND) .....	79
5.1	CONDUCTED EMISSION MEASUREMENT .....	79
5.1.1	LIMITS OF CONDUCTED EMISSION MEASUREMENT.....	79
5.1.2	TEST INSTRUMENTS.....	79
5.1.3	TEST PROCEDURES .....	80
5.1.4	DEVIATION FROM TEST STANDARD .....	80
5.1.5	TEST SETUP .....	81
5.1.6	EUT OPERATING CONDITIONS .....	81
5.1.7	TEST RESULTS .....	82
5.2	RADIATED EMISSION MEASUREMENT .....	88
5.2.1	LIMITS OF RADIATED EMISSION MEASUREMENT.....	88
5.2.2	TEST INSTRUMENTS.....	89
5.2.3	TEST PROCEDURES .....	90
5.2.4	DEVIATION FROM TEST STANDARD .....	90
5.2.5	TEST SETUP .....	91
5.2.6	EUT OPERATING CONDITIONS .....	91
5.2.7	TEST RESULTS .....	92
5.3	6dB BANDWIDTH MEASUREMENT .....	98
5.3.1	LIMITS OF 6dB BANDWIDTH MEASUREMENT .....	98
5.3.2	TEST INSTRUMENTS.....	98
5.3.3	TEST PROCEDURE.....	99
5.3.4	DEVIATION FROM TEST STANDARD .....	99
5.3.5	TEST SETUP .....	99
5.3.6	EUT OPERATING CONDITIONS .....	99
5.3.7	TEST RESULTS .....	100
5.4	MAXIMUM PEAK OUTPUT POWER .....	103
5.4.1	LIMITS OF MAXIMUM PEAK OUTPUT POWER MEASUREMENT.....	103
5.4.2	INSTRUMENTS.....	103
5.4.3	TEST PROCEDURES .....	104
5.4.4	DEVIATION FROM TEST STANDARD .....	104
5.4.5	TEST SETUP .....	104
5.4.6	EUT OPERATING CONDITIONS .....	104
5.4.7	TEST RESULTS .....	105
5.5	POWER SPECTRAL DENSITY MEASUREMENT.....	106
5.5.1	LIMITS OF POWER SPECTRAL DENSITY MEASUREMENT .....	106
5.5.2	TEST INSTRUMENTS.....	106



5.5.3	TEST PROCEDURE.....	107
5.5.4	DEVIATION FROM TEST STANDARD .....	107
5.5.5	TEST SETUP .....	107
5.5.6	EUT OPERATING CONDITION .....	107
5.5.7	TEST RESULTS .....	108
5.6	BAND EDGES MEASUREMENT .....	111
5.6.1	LIMITS OF BAND EDGES MEASUREMENT .....	111
5.6.2	TEST INSTRUMENTS.....	111
5.6.3	TEST PROCEDURE.....	111
5.6.4	DEVIATION FROM TEST STANDARD .....	111
5.6.5	EUT OPERATING CONDITION .....	112
5.6.6	TEST RESULTS .....	112
5.7	ANTENNA REQUIREMENT .....	116
5.7.1	STANDARD APPLICABLE .....	116
5.7.2	ANTENNA CONNECTED CONSTRUCTION.....	116
6.	PHOTOGRAPHS OF THE TEST CONFIGURATION.....	117
7.	INFORMATION ON THE TESTING LABORATORIES .....	123



## 1. CERTIFICATION

**PRODUCT:** VA4200 Wi-Fi AP/Bridge  
**BRAND NAME:** VIVATO  
**MODEL NO.:** VA4200  
**APPLICANT:** Vivato, Inc.  
**TEST SAMPLE:** ENGINEERING SAMPLE  
**TESTED:** Apr. 02 ~ Jul. 04, 2005  
**STANDARDS:** FCC Part 15, Subpart C (Section 15.247),  
ANSI C63.4-2003

The above equipment has been tested by **Advance Data Technology Corporation**, and found compliance with the requirement of the above standards. The test record, data evaluation & Equipment Under Test (EUT) configurations represented herein are true and accurate accounts of the measurements of the sample's EMC characteristics under the conditions specified in this report.

**PREPARED BY :** Andrea Hsia , **DATE:** Jul. 04, 2005  
( Andrea Hsia )

**TECHNICAL**  
**ACCEPTANCE :** Gary Chang , **DATE:** Jul. 04, 2005  
Responsible for RF ( Gary Chang )

**APPROVED BY :** Cody Chang , **DATE:** Jul. 04, 2005  
( Cody Chang, Deputy Manager )

## 2. SUMMARY OF TEST RESULTS

The EUT has been tested according to the following specifications:

<b>APPLIED STANDARD: FCC Part 15, Subpart C (Section 15.247)</b>			
<b>Standard Section</b>	<b>Test Type and Limit</b>	<b>Result</b>	<b>Remark</b>
15.207	AC Power Conducted Emission	PASS	Meet the requirement of limit. Minimum passing margin is -5.39dB at 0.177MHz
15.247(a)(2)	Spectrum Bandwidth of a Direct Sequence Spread Spectrum System Limit: min. 500kHz	PASS	Meet the requirement of limit.
15.247(b)	Maximum Peak Output Power Limit: max. 30dBm	PASS	Meet the requirement of limit.
15.247(d)	Radiated Emissions Limit: Table 15.209	PASS	Meet the requirement of limit. Minimum passing margin is -1.11dB at 2483.50MHz
15.247(e)	Power Spectral Density Limit: max. 8dBm	PASS	Meet the requirement of limit.
15.247(d)	Band Edge Measurement Limit: 20dB less than the peak value of fundamental frequency	PASS	Meet the requirement of limit.

### 2.1 MEASUREMENT UNCERTAINTY

Where relevant, the following measurement uncertainty levels have been estimated for tests performed on the EUT as specified in CISPR 16-4:

<b>Measurement</b>	<b>Frequency</b>	<b>Uncertainty</b>
Conducted emissions	9kHz~30MHz	2.44 dB
Radiated emissions	30MHz ~ 200MHz	3.73 dB
	200MHz ~1000MHz	3.74 dB
	1GHz ~ 18GHz	2.20 dB
	18GHz ~ 40GHz	1.88 dB



### 3. GENERAL INFORMATION

#### 3.1 GENERAL DESCRIPTION OF EUT

<b>EUT</b>	VA4200 Wi-Fi AP/Bridge
<b>MODEL NO.</b>	VA4200
<b>POWER SUPPLY</b>	12Vdc from AC Adapter 48Vdc from POE
<b>MODULATION TYPE</b>	CCK, DQPSK, DBPSK for DSSS 64QAM, 16QAM, QPSK, BPSK for OFDM
<b>MODULATION TECHNOLOGY</b>	DSSS, OFDM
<b>TRANSFER RATE</b>	802.11b: 11/5.5/2/1Mbps 802.11g: 54/48/36/24/18/12/9/6Mbps 802.11a: 54/48/36/24/18/12/9/6Mbps (Turbo mode: up to 108Mbps *see Note 4)
<b>FREQUENCY RANGE</b>	802.11b & 802.11g: 2.412 ~ 2.462GHz 802.11a: 5.150 ~ 5.350GHz and 5.725 ~ 5.850GHz
<b>NUMBER OF CHANNEL</b>	802.11b & 802.11g: 11 802.11a: 13 for Normal mode / 3 for Turbo mode
<b>CHANNEL SPACING</b>	802.11b & 802.11g: 5MHz 802.11a: 20MHz for Normal mode / 40MHz for Turbo mode
<b>OUTPUT POWER</b>	101.158mW for 802.11b 57.280mW for 802.11g 63.973mW for 5.150 ~ 5.350GHz 70.958mW for 5.725 ~ 5.850GHz
<b>ANTENNA TYPE</b>	Dipole antenna with 2.0dBi gain
<b>DATA CABLE</b>	NA
<b>I/O PORTS</b>	RJ45
<b>ASSOCIATED DEVICES</b>	NA

**NOTE:**

- The EUT were operated with following power adapters:

<b>BRAND:</b>	JET
<b>MODEL:</b>	RHE-120150-7
<b>INPUT:</b>	120-240Vac, 50/60Hz, 0.7A
<b>OUTPUT:</b>	12Vdc, 1.5A
<b>POWER LINE:</b>	DC 1.8m non-shielded cable without core AC 1.6m non-shielded cable without core

<b>BRAND:</b>	LEI (LEADER ELECTRONICS INC.)
<b>MODEL:</b>	NU20-5120200-I2
<b>INPUT:</b>	100-240Vac, 50/60Hz, 1A
<b>OUTPUT:</b>	12Vdc, 2.0A
<b>POWER LINE:</b>	DC 1.8m non-shielded cable with one core AC 1.6m non-shielded cable without core



2. The EUT was operated with following POE:

<b>BRAND:</b>	Gemtek Systems E-120 POE HUB
<b>MODEL:</b>	PWI30RB4800N52
<b>INPUT:</b>	100-250Vac, 50/60Hz, 500mA
<b>OUTPUT:</b>	48Vdc, 350mA
<b>POWER LINE:</b>	AC 1.6m non-shielded cable without core

3. The EUT operates in both the 5GHz and 2.4GHz Bands and compatibility with 802.11a and 802.11b, 802.11g technology.
4. This EUT is capable of providing data rates of up to 108 Mbps in Turbo mode depending upon reception quality and the turbo mode only use in the frequency range 5150MHz ~ 5350MHz.
5. The above EUT information was declared by the manufacturer and for more detailed features description, please refer to the manufacturer's specifications or User's Manual.





### 3.2 DESCRIPTION OF TEST MODES

Operated in 2400 ~ 2483.5MHz band:

For 802.11b/g: Eleven channels are provided to this EUT.

Channel	Frequency	Channel	Frequency
1	2412 MHz	7	2442 MHz
2	2417 MHz	8	2447 MHz
3	2422 MHz	9	2452 MHz
4	2427 MHz	10	2457 MHz
5	2432 MHz	11	2462 MHz
6	2437 MHz		

Operated in 5725 ~ 5850MHz band:

For 802.11a: five channels are provided to this EUT.

Channel	Frequency
1	5745 MHz
2	5765 MHz
3	5785 MHz
4	5805 MHz
5	5825 MHz

### 3.2.1 CONFIGURATION OF SYSTEM UNDER TEST

#### Test Mode 1 & 2

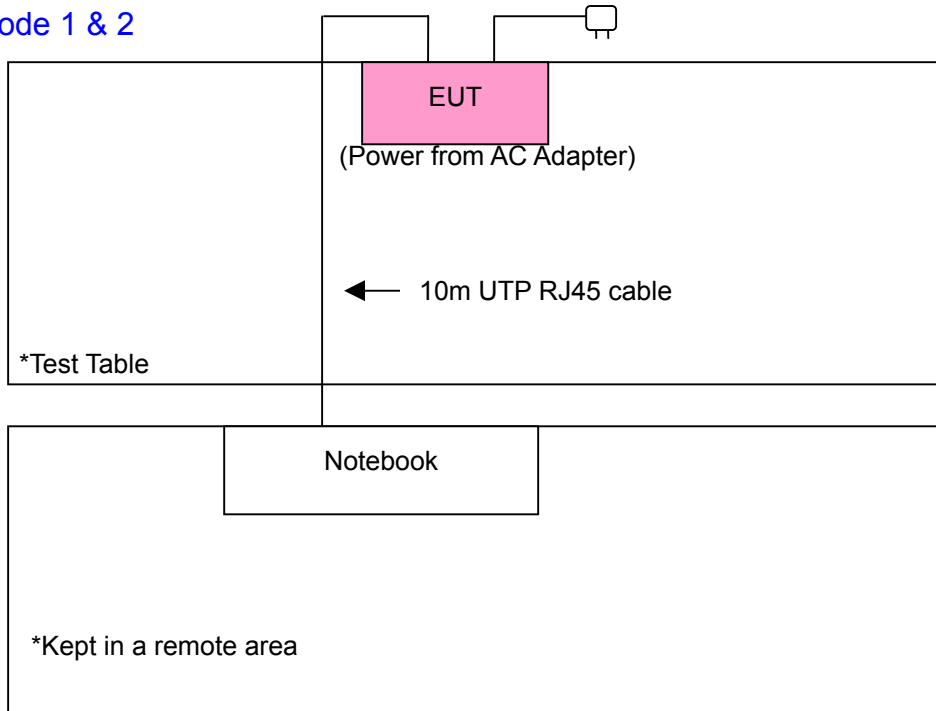

#### Test Mode 3

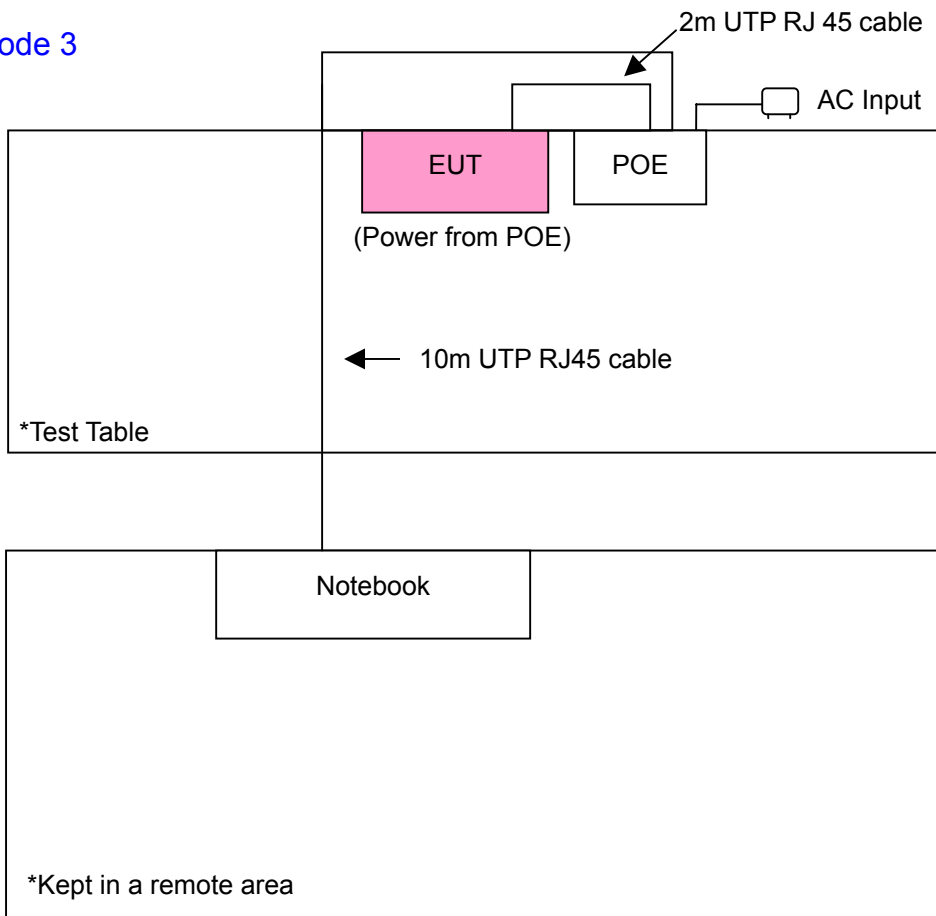



3.2.2 TEST MODE APPLICABILITY AND TESTED CHANNEL DETAIL:

EUT configure mode	Applicable to				Description
	PLC	RE<1G	RE≥1G	APCM	
1	v	v	Note1	Note 2	Power from AC adapter (RHE-120150-7)
2	v	v	Note1	Note 2	Power from AC adapter (NU20-5120200-12)
3	v	v	Note1	Note 2	Power from POE

Where PLC: Power Line Conducted Emission RE<1G RE: Radiated Emission below 1GHz  
 RE≥1G: Radiated Emission above 1GHz APCM: Antenna Port Conducted Measurement

Note 1: No effect on Radiated Emission above 1GHz.

Note 2: No effect on Conducted RF measurement.

**Power Line Conducted Emission Test:**

- Pre-Scan has been conducted to determine the worst-case mode from all possible combinations between available modulations, data rates and antenna ports (if EUT with antenna diversity architecture).
- Following channel(s) was (were) selected for the final test as listed below.

EUT configure mode	Mode	Available Channel	Tested Channel	Modulation Technology	Modulation Type	Data Rate (Mbps)
1	802.11g	1 to 11	1, 6, 11	OFDM	BPSK	6
1	802.11a	1 to 5	1	OFDM	BPSK	6
2	802.11g	1 to 11	1, 6, 11	OFDM	BPSK	6
2	802.11a	1 to 5	1	OFDM	BPSK	6
3	802.11g	1 to 11	1, 6, 11	OFDM	BPSK	6
3	802.11a	1 to 5	1	OFDM	BPSK	6

**Radiated Emission Test (Below 1 GHz):**

- Pre-Scan has been conducted to determine the worst-case mode from all possible combinations between available modulations, data rates and antenna ports (if EUT with antenna diversity architecture).
- Following channel(s) was (were) selected for the final test as listed below.

EUT configure mode	Mode	Available Channel	Tested Channel	Modulation Technology	Modulation Type	Data Rate (Mbps)
1	802.11g	1 to 11	1	OFDM	BPSK	6
1	802.11a	1 to 5	1	OFDM	BPSK	6
2	802.11g	1 to 11	1	OFDM	BPSK	6
2	802.11a	1 to 5	1	OFDM	BPSK	6
3	802.11g	1 to 11	1	OFDM	BPSK	6
3	802.11a	1 to 5	1	OFDM	BPSK	6



### **Radiated Emission Test (Above 1 GHz):**

- Pre-Scan has been conducted to determine the worst-case mode from all possible combinations between available modulations, data rates and antenna ports (if EUT with antenna diversity architecture).
- Following channel(s) was (were) selected for the final test as listed below.

EUT configure mode	Mode	Available Channel	Tested Channel	Modulation Technology	Modulation Type	Data Rate (Mbps)
3	802.11b	1 to 11	1, 6, 11	DSSS	CCK	11
3	802.11g	1 to 11	1, 6, 11	OFDM	BPSK	6
3	802.11a	1 to 5	1, 3, 5	OFDM	BPSK	6

### **Bandedge Measurement:**

- Pre-Scan has been conducted to determine the worst-case mode from all possible combinations between available modulations, data rates and antenna ports (if EUT with antenna diversity architecture).
- Following channel(s) was (were) selected for the final test as listed below.

Mode	Available Channel	Tested Channel	Modulation Technology	Modulation Type	Data Rate (Mbps)
802.11b	1 to 11	1, 11	DSSS	CCK	11
802.11g	1 to 11	1, 11	OFDM	BPSK	6
802.11a	1 to 5	1, 5	OFDM	BPSK	6

### **Antenna Port Conducted Measurement:**

- Pre-Scan has been conducted to determine the worst-case mode from all possible combinations between available modulations, data rates and antenna ports (if EUT with antenna diversity architecture).
- Following channel(s) was (were) selected for the final test as listed below.

Mode	Available Channel	Tested Channel	Modulation Technology	Modulation Type	Data Rate (Mbps)
802.11b	1 to 11	1, 6, 11	DSSS	CCK	11
802.11g	1 to 11	1, 6, 11	OFDM	BPSK	6
802.11a	1 to 5	1, 3, 5	OFDM	BPSK	6



### 3.3 GENERAL DESCRIPTION OF APPLIED STANDARDS

The EUT is a VA4200 Wi-Fi AP/Bridge. According to the specifications of the manufacturer, it must comply with the requirements of the following standards:

#### FCC Part 15, Subpart C. (15.247)

#### ANSI C63.4-2003

All test items have been performed and recorded as per the above standards.

**NOTE:** The EUT is also considered as a kind of computer peripheral, because the connection to computer is necessary for typical use. It has been verified to comply with the requirements of FCC Part 15, Subpart B, Class B (DoC). The test report has been issued separately.

### 3.4 DESCRIPTION OF SUPPORT UNITS

The EUT has been tested as an independent unit together with other necessary accessories or support units. The following support units or accessories were used to form a representative test configuration during the tests.

NO.	PRODUCT	BRAND	MODEL NO.	SERIAL NO.	FCC ID
1	NOTEBOOK COMPUTER	DELL	PP05L	12130898320	E2K24CLNS

NO.	SIGNAL CABLE DESCRIPTION OF THE ABOVE SUPPORT UNITS
1	NA

**NOTE:** All power cords of the above support units are non shielded (1.8m).



## 4. TEST TYPES AND RESULTS (802.11b & g 2412~2462MHz Band)

### 4.1 CONDUCTED EMISSION MEASUREMENT

#### 4.1.1 LIMITS OF CONDUCTED EMISSION MEASUREMENT

FREQUENCY OF EMISSION (MHz)	CONDUCTED LIMIT (dB $\mu$ V)	
	Quasi-peak	Average
0.15-0.5	66 to 56	56 to 46
0.5-5	56	46
5-30	60	50

- NOTE:**
1. The lower limit shall apply at the transition frequencies.
  2. The limit decreases in line with the logarithm of the frequency in the range of 0.15 to 0.50 MHz.
  3. All emanations from a class A/B digital device or system, including any network of conductors and apparatus connected thereto, shall not exceed the level of field strengths specified above.

#### 4.1.2 TEST INSTRUMENTS

DESCRIPTION & MANUFACTURER	MODEL NO.	SERIAL NO.	CALIBRATED UNTIL
Test Receiver ROHDE & SCHWARZ	ESCS30	100288	Nov. 06, 2005
RF signal cable Woken	5D-FB	Cable-HyC02-01	Jan. 09, 2006
LISN ROHDE & SCHWARZ	ESH2-Z5	100100	Jan. 20, 2006
LISN ROHDE & SCHWARZ	ESH3-Z5	100311	Jan. 20, 2006
Software ADT	ADT_Cond_V3	NA	NA

- NOTE:**
1. The calibration interval of the above test instruments is 12 months and the calibrations are traceable to NML/ROC and NIST/USA.
  2. The test was performed in HwaYa Shielded Room 3.
  3. The VCCI Site Registration No. is C-2047.



#### 4.1.3 TEST PROCEDURES

- a. The EUT was placed 0.4 meters from the conducting wall of the shielded room with EUT being connected to the power mains through a line impedance stabilization network (LISN). Other support units were connected to the power mains through another LISN. The two LISNs provide 50 ohm/ 50uH of coupling impedance for the measuring instrument.
- b. Both lines of the power mains connected to the EUT were checked for maximum conducted interference.
- c. The frequency range from 150kHz to 30MHz was searched. Emission levels under (Limit - 20dB) was not recorded.

#### 4.1.4 DEVIATION FROM TEST STANDARD

No deviation

#### 4.1.5 TEST SETUP

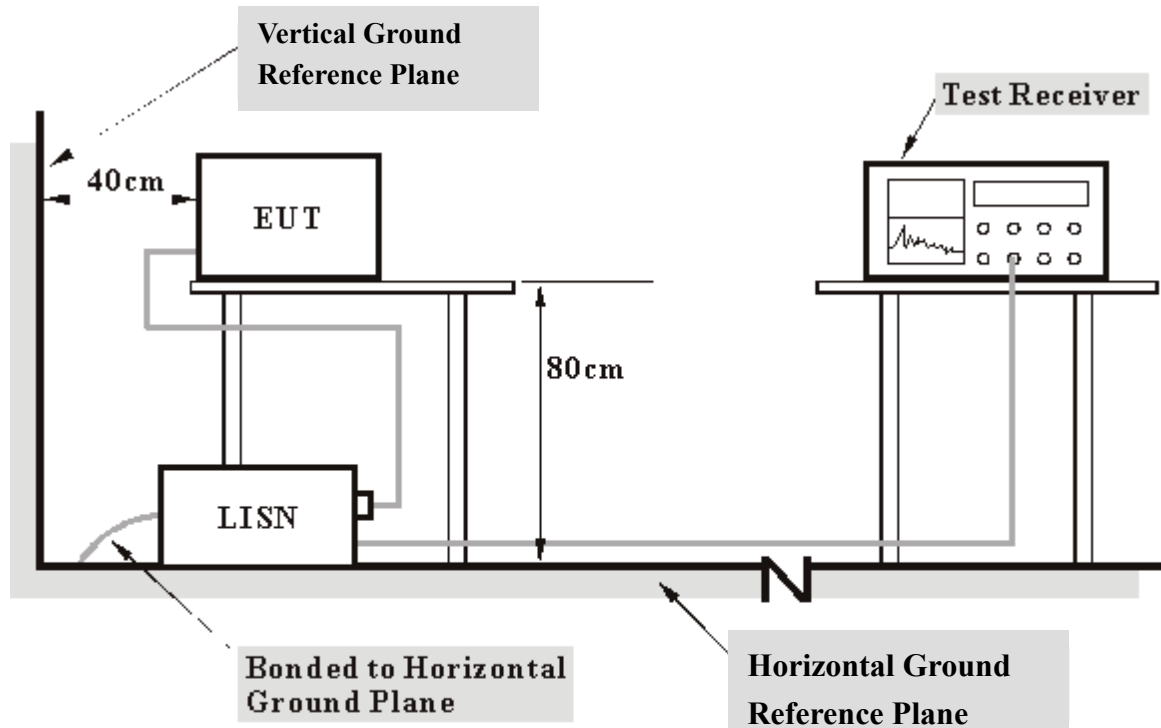

- Note:**
1. Support units were connected to second LISN.
  2. Both of LISNs (AMN) 80 cm from EUT and at the least 80 cm from other units and other metal planes support units.

For the actual test configuration, please refer to the related item – Photographs of the Test Configuration.

#### 4.1.6 EUT OPERATING CONDITIONS

- a. Placed the EUT on the testing table.
- b. Prepared another notebook system to act as a communication partner and placed it outside of testing area.
- c. The communication partner run a test program (provided by manufacturer) to enable EUT under transmission/receiving condition continuously at specific channel frequency via an RJ45 cable.
- d. The communication partner sent data to EUT by command "PING".





4.1.7 TEST RESULTS

**Conducted Worst-Case Data (Power from AC Adapter: RHE-120150-7)**

<b>EUT</b>	VA4200 Wi-Fi AP/Bridge	<b>MEASUREMENT DETAIL</b>	
<b>MODEL</b>	VA4200	<b>PHASE</b>	Line 1
<b>CHANNEL</b>	Channel 1	<b>6dB BANDWIDTH</b>	9 kHz
<b>MODULATION TYPE</b>	BPSK	<b>ENVIRONMENTAL CONDITIONS</b>	23deg. C, 65%RH, 991hPa
<b>TRANSFER RATE</b>	6Mbps	<b>INPUT POWER (SYSTEM)</b>	120Vac, 60 Hz
<b>TEST MODE</b>	1	<b>TESTED BY</b>	Gary Chang

No	Freq. [MHz]	Corr. Factor (dB)	Reading Value [dB (uV)]		Emission Level [dB (uV)]		Limit [dB (uV)]		Margin (dB)	
			Q.P.	AV.	Q.P.	AV.	Q.P.	AV.	Q.P.	AV.
			1	0.176	0.10	54.36	-	54.46	-	64.67
2	0.236	0.10	47.88	-	47.98	-	62.24	52.24	-14.26	-
3	0.533	0.12	41.76	-	41.88	-	56.00	46.00	-14.12	-
4	0.595	0.13	39.14	-	39.27	-	56.00	46.00	-16.73	-
5	13.422	0.37	36.46	-	36.83	-	60.00	50.00	-23.17	-
6	19.711	0.78	39.41	-	40.19	-	60.00	50.00	-19.81	-

- REMARKS:**
1. Q.P. and AV. are abbreviations of quasi-peak and average individually.
  2. "-": The Quasi-peak reading value also meets average limit and measurement with the average detector is unnecessary.
  3. The emission levels of other frequencies were very low against the limit.
  4. Margin value = Emission level - Limit value
  5. Correction factor = Insertion loss + Cable loss
  6. Emission Level = Correction Factor + Reading Value.

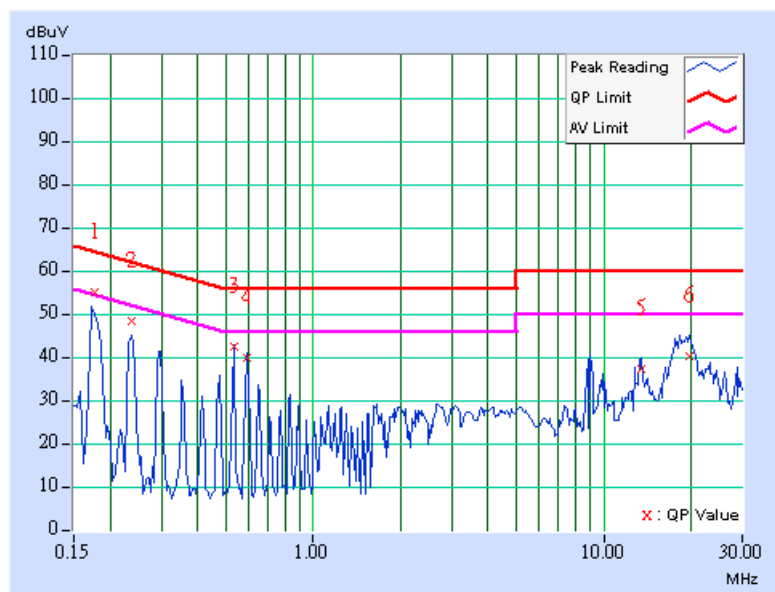



<b>EUT</b>	VA4200 Wi-Fi AP/Bridge	<b>MEASUREMENT DETAIL</b>	
<b>MODEL</b>	VA4200	<b>PHASE</b>	Line 2
<b>CHANNEL</b>	Channel 1	<b>6dB BANDWIDTH</b>	9 kHz
<b>MODULATION TYPE</b>	BPSK	<b>ENVIRONMENTAL CONDITIONS</b>	23deg. C, 65%RH, 991hPa
<b>TRANSFER RATE</b>	6Mbps	<b>INPUT POWER (SYSTEM)</b>	120Vac, 60 Hz
<b>TEST MODE</b>	1	<b>TESTED BY</b>	Gary Chang

No	Freq. [MHz]	Corr. Factor (dB)	Reading Value		Emission Level		Limit		Margin	
			[dB (uV)]		[dB (uV)]		[dB (uV)]		(dB)	
			Q.P.	AV.	Q.P.	AV.	Q.P.	AV.	Q.P.	AV.
1	0.177	0.10	55.06	49.12	55.16	49.22	64.61	54.61	-9.45	-5.39
2	0.236	0.10	48.69	-	48.79	-	62.24	52.24	-13.45	-
3	0.295	0.10	44.36	-	44.46	-	60.40	50.40	-15.94	-
4	0.533	0.12	42.90	-	43.02	-	56.00	46.00	-12.98	-
5	13.418	0.47	38.03	-	38.50	-	60.00	50.00	-21.50	-
6	18.980	0.74	38.60	-	39.34	-	60.00	50.00	-20.66	-

- REMARKS:**
1. Q.P. and AV. are abbreviations of quasi-peak and average individually.
  2. "-": The Quasi-peak reading value also meets average limit and measurement with the average detector is unnecessary.
  3. The emission levels of other frequencies were very low against the limit.
  4. Margin value = Emission level - Limit value
  5. Correction factor = Insertion loss + Cable loss
  6. Emission Level = Correction Factor + Reading Value.

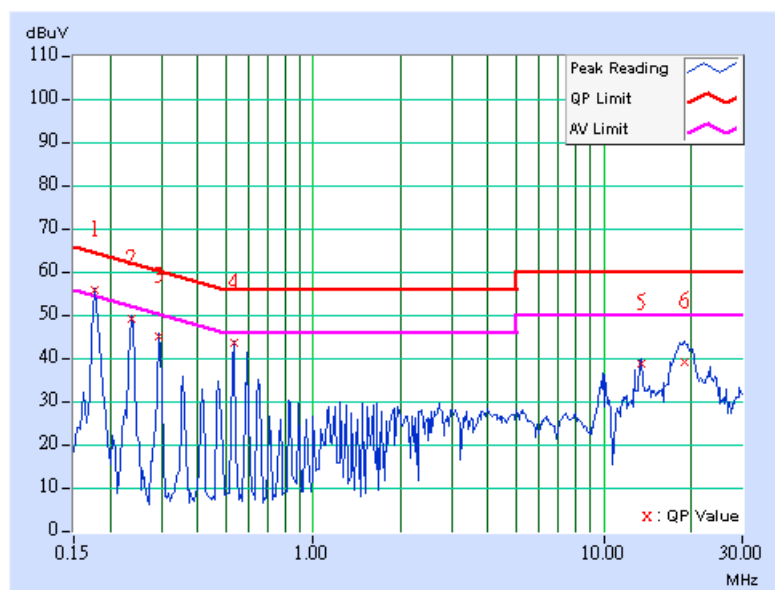



<b>EUT</b>	VA4200 Wi-Fi AP/Bridge	<b>MEASUREMENT DETAIL</b>	
<b>MODEL</b>	VA4200	<b>PHASE</b>	Line 1
<b>CHANNEL</b>	Channel 6	<b>6dB BANDWIDTH</b>	9 kHz
<b>MODULATION TYPE</b>	BPSK	<b>ENVIRONMENTAL CONDITIONS</b>	23deg. C, 65%RH, 991hPa
<b>TRANSFER RATE</b>	6Mbps	<b>INPUT POWER (SYSTEM)</b>	120Vac, 60 Hz
<b>TEST MODE</b>	1	<b>TESTED BY</b>	Gary Chang

No	Freq. [MHz]	Corr. Factor (dB)	Reading Value		Emission Level		Limit		Margin	
			[dB (uV)]		[dB (uV)]		[dB (uV)]		(dB)	
			Q.P.	AV.	Q.P.	AV.	Q.P.	AV.	Q.P.	AV.
1	0.177	0.10	54.40	-	54.50	-	64.61	54.61	-10.11	-
2	0.236	0.10	47.77	-	47.87	-	62.24	52.24	-14.37	-
3	0.295	0.10	43.04	-	43.14	-	60.40	50.40	-17.26	-
4	0.529	0.12	40.83	-	40.95	-	56.00	46.00	-15.05	-
5	13.418	0.37	37.73	-	38.10	-	60.00	50.00	-21.90	-
6	19.031	0.72	38.12	-	38.84	-	60.00	50.00	-21.16	-

- REMARKS:**
1. Q.P. and AV. are abbreviations of quasi-peak and average individually.
  2. "-": The Quasi-peak reading value also meets average limit and measurement with the average detector is unnecessary.
  3. The emission levels of other frequencies were very low against the limit.
  4. Margin value = Emission level - Limit value
  5. Correction factor = Insertion loss + Cable loss
  6. Emission Level = Correction Factor + Reading Value.

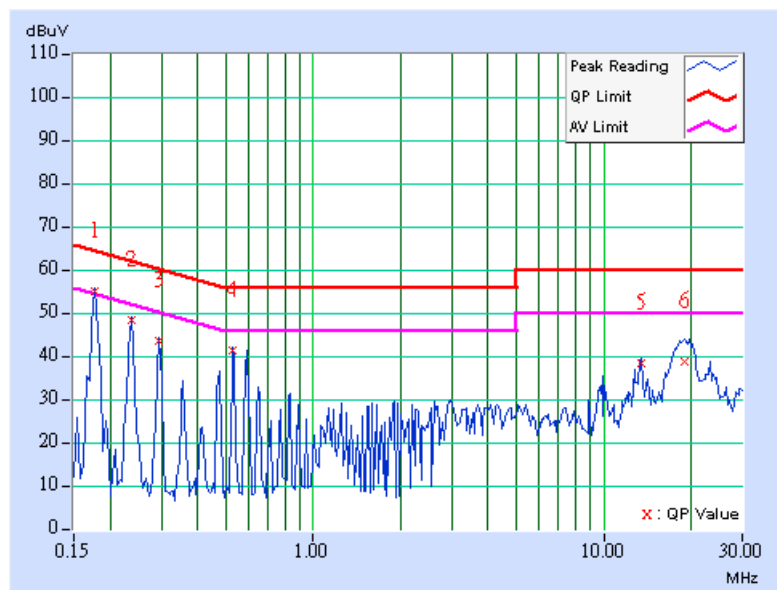



<b>EUT</b>	VA4200 Wi-Fi AP/Bridge	<b>MEASUREMENT DETAIL</b>	
<b>MODEL</b>	VA4200	<b>PHASE</b>	Line 2
<b>CHANNEL</b>	Channel 6	<b>6dB BANDWIDTH</b>	9 kHz
<b>MODULATION TYPE</b>	BPSK	<b>ENVIRONMENTAL CONDITIONS</b>	23deg. C, 65%RH, 991hPa
<b>TRANSFER RATE</b>	6Mbps	<b>INPUT POWER (SYSTEM)</b>	120Vac, 60 Hz
<b>TEST MODE</b>	1	<b>TESTED BY</b>	Gary Chang

No	Freq. [MHz]	Corr. Factor (dB)	Reading Value [dB (uV)]		Emission Level [dB (uV)]		Limit [dB (uV)]		Margin (dB)	
			Q.P.	AV.	Q.P.	AV.	Q.P.	AV.	Q.P.	AV.
			1	0.173	0.10	51.27	-	51.37	-	64.79
2	0.236	0.10	48.51	-	48.61	-	62.24	52.24	-13.63	-
3	0.295	0.10	44.08	-	44.18	-	60.40	50.40	-16.22	-
4	0.533	0.12	42.29	-	42.41	-	56.00	46.00	-13.59	-
5	13.418	0.47	38.05	-	38.52	-	60.00	50.00	-21.48	-
6	18.246	0.69	39.60	-	40.29	-	60.00	50.00	-19.71	-

- REMARKS:**
1. Q.P. and AV. are abbreviations of quasi-peak and average individually.
  2. "-": The Quasi-peak reading value also meets average limit and measurement with the average detector is unnecessary.
  3. The emission levels of other frequencies were very low against the limit.
  4. Margin value = Emission level - Limit value
  5. Correction factor = Insertion loss + Cable loss
  6. Emission Level = Correction Factor + Reading Value.

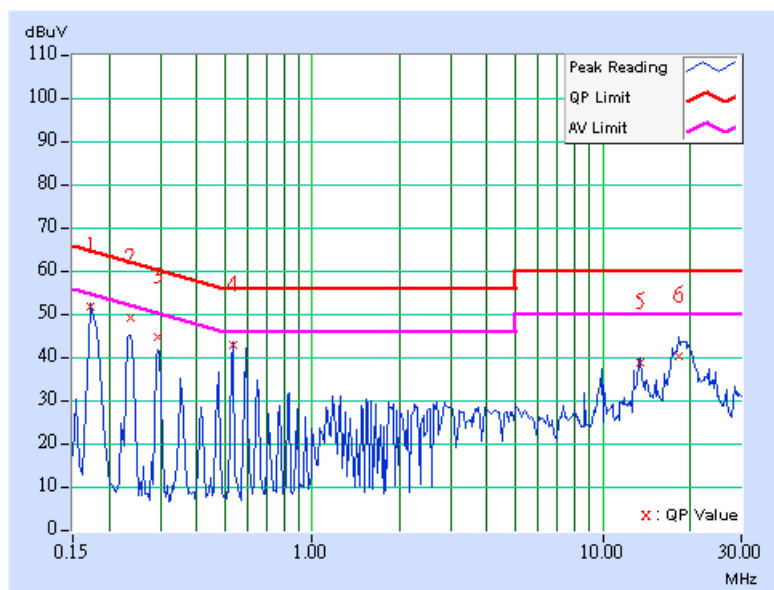



<b>EUT</b>	VA4200 Wi-Fi AP/Bridge	<b>MEASUREMENT DETAIL</b>	
<b>MODEL</b>	VA4200	<b>PHASE</b>	Line 1
<b>CHANNEL</b>	Channel 11	<b>6dB BANDWIDTH</b>	9 kHz
<b>MODULATION TYPE</b>	BPSK	<b>ENVIRONMENTAL CONDITIONS</b>	23deg. C, 65%RH, 991hPa
<b>TRANSFER RATE</b>	6Mbps	<b>INPUT POWER (SYSTEM)</b>	120Vac, 60 Hz
<b>TEST MODE</b>	1	<b>TESTED BY</b>	Gary Chang

No	Freq. [MHz]	Corr. Factor (dB)	Reading Value [dB (uV)]		Emission Level [dB (uV)]		Limit [dB (uV)]		Margin (dB)	
			Q.P.	AV.	Q.P.	AV.	Q.P.	AV.	Q.P.	AV.
			1	0.177	0.10	54.18	-	54.28	-	64.61
2	0.236	0.10	47.49	-	47.59	-	62.24	52.24	-14.65	-
3	0.529	0.12	41.23	-	41.35	-	56.00	46.00	-14.65	-
4	0.591	0.13	40.01	-	40.14	-	56.00	46.00	-15.86	-
5	13.418	0.37	37.71	-	38.08	-	60.00	50.00	-21.92	-
6	18.238	0.66	38.12	-	38.78	-	60.00	50.00	-21.22	-

- REMARKS:**
1. Q.P. and AV. are abbreviations of quasi-peak and average individually.
  2. "-": The Quasi-peak reading value also meets average limit and measurement with the average detector is unnecessary.
  3. The emission levels of other frequencies were very low against the limit.
  4. Margin value = Emission level - Limit value
  5. Correction factor = Insertion loss + Cable loss
  6. Emission Level = Correction Factor + Reading Value.

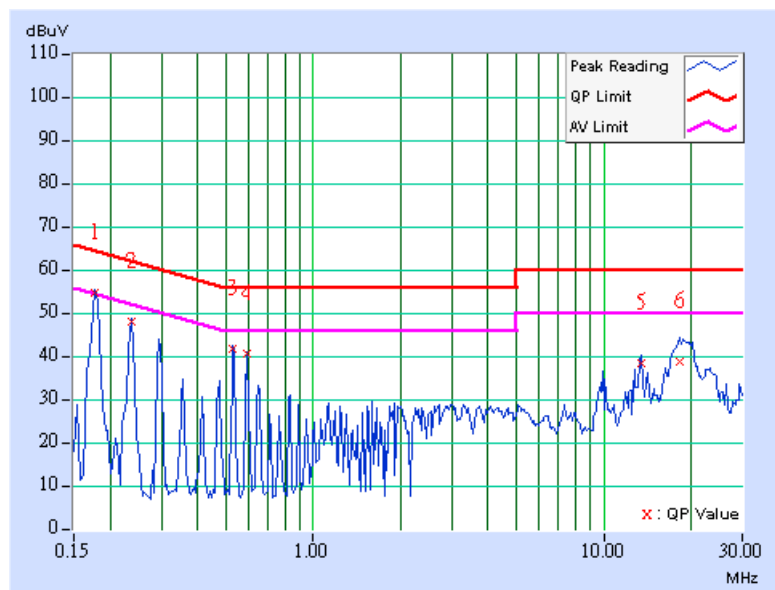



<b>EUT</b>	VA4200 Wi-Fi AP/Bridge	<b>MEASUREMENT DETAIL</b>	
<b>MODEL</b>	VA4200	<b>PHASE</b>	Line 2
<b>CHANNEL</b>	Channel 11	<b>6dB BANDWIDTH</b>	9 kHz
<b>MODULATION TYPE</b>	BPSK	<b>ENVIRONMENTAL CONDITIONS</b>	23deg. C, 65%RH, 991hPa
<b>TRANSFER RATE</b>	6Mbps	<b>INPUT POWER (SYSTEM)</b>	120Vac, 60 Hz
<b>TEST MODE</b>	1	<b>TESTED BY</b>	Gary Chang

No	Freq. [MHz]	Corr. Factor (dB)	Reading Value [dB (uV)]		Emission Level [dB (uV)]		Limit [dB (uV)]		Margin (dB)	
			Q.P.	AV.	Q.P.	AV.	Q.P.	AV.	Q.P.	AV.
			1	0.177	0.10	54.50	-	54.60	-	64.61
2	0.236	0.10	48.34	-	48.44	-	62.24	52.24	-13.80	-
3	0.295	0.10	44.08	-	44.18	-	60.40	50.40	-16.22	-
4	0.533	0.12	42.72	-	42.84	-	56.00	46.00	-13.16	-
5	13.418	0.47	38.03	-	38.50	-	60.00	50.00	-21.50	-
6	17.695	0.66	38.98	-	39.64	-	60.00	50.00	-20.36	-

- REMARKS:**
1. Q.P. and AV. are abbreviations of quasi-peak and average individually.
  2. "-": The Quasi-peak reading value also meets average limit and measurement with the average detector is unnecessary.
  3. The emission levels of other frequencies were very low against the limit.
  4. Margin value = Emission level - Limit value
  5. Correction factor = Insertion loss + Cable loss
  6. Emission Level = Correction Factor + Reading Value.

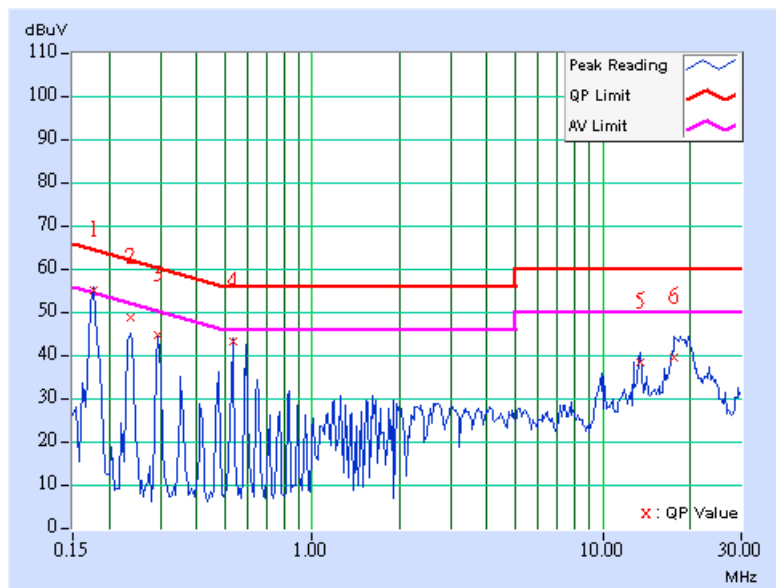



**Conducted Worst-Case Data (Power from AC Adapter: NU20-5120200-I2)**

<b>EUT</b>	VA4200 Wi-Fi AP/Bridge	<b>MEASUREMENT DETAIL</b>	
<b>MODEL</b>	VA4200	<b>PHASE</b>	Line 1
<b>CHANNEL</b>	Channel 1	<b>6dB BANDWIDTH</b>	9 kHz
<b>MODULATION TYPE</b>	BPSK	<b>ENVIRONMENTAL CONDITIONS</b>	23deg. C, 65%RH, 991hPa
<b>TRANSFER RATE</b>	6Mbps	<b>INPUT POWER (SYSTEM)</b>	120Vac, 60 Hz
<b>TEST MODE</b>	2	<b>TESTED BY</b>	Gary Chang

No	Freq. [MHz]	Corr. Factor (dB)	Reading Value [dB (uV)]		Emission Level [dB (uV)]		Limit [dB (uV)]		Margin (dB)	
			Q.P.	AV.	Q.P.	AV.	Q.P.	AV.	Q.P.	AV.
			1	0.201	0.11	35.15	-	35.26	-	63.58
2	0.263	0.11	32.01	-	32.12	-	61.33	51.33	-29.21	-
3	0.396	0.11	27.62	-	27.73	-	57.93	47.93	-30.20	-
4	0.791	0.19	25.38	-	25.57	-	56.00	46.00	-30.43	-
5	2.695	0.31	31.09	-	31.40	-	56.00	46.00	-24.60	-
6	9.273	0.52	30.22	-	30.74	-	60.00	50.00	-29.26	-

- REMARKS:**
1. Q.P. and AV. are abbreviations of quasi-peak and average individually.
  2. "-": The Quasi-peak reading value also meets average limit and measurement with the average detector is unnecessary.
  3. The emission levels of other frequencies were very low against the limit.
  4. Margin value = Emission level - Limit value
  5. Correction factor = Insertion loss + Cable loss
  6. Emission Level = Correction Factor + Reading Value.

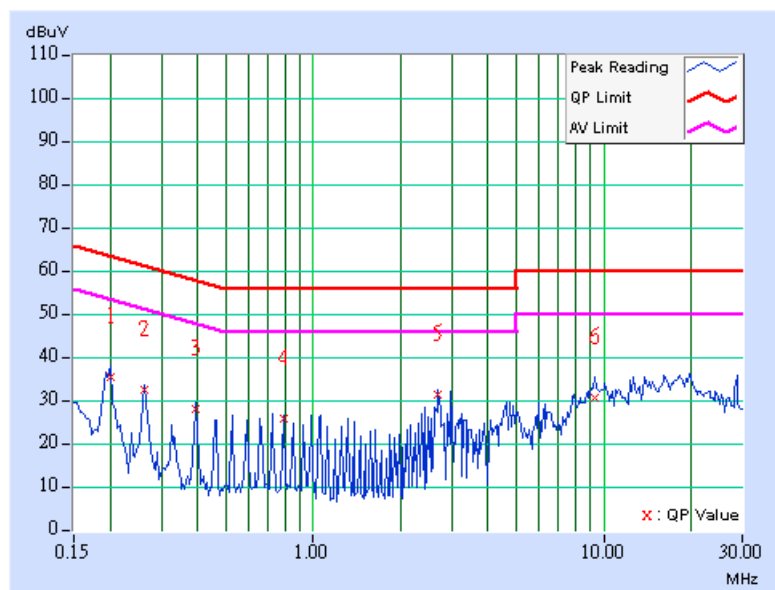



<b>EUT</b>	VA4200 Wi-Fi AP/Bridge	<b>MEASUREMENT DETAIL</b>	
<b>MODEL</b>	VA4200	<b>PHASE</b>	Line 2
<b>CHANNEL</b>	Channel 1	<b>6dB BANDWIDTH</b>	9 kHz
<b>MODULATION TYPE</b>	BPSK	<b>ENVIRONMENTAL CONDITIONS</b>	23deg. C, 65%RH, 991hPa
<b>TRANSFER RATE</b>	6Mbps	<b>INPUT POWER (SYSTEM)</b>	120Vac, 60 Hz
<b>TEST MODE</b>	2	<b>TESTED BY</b>	Gary Chang

No	Freq. [MHz]	Corr. Factor (dB)	Reading Value		Emission Level		Limit		Margin	
			[dB (uV)]		[dB (uV)]		[dB (uV)]		(dB)	
			Q.P.	AV.	Q.P.	AV.	Q.P.	AV.	Q.P.	AV.
1	0.197	0.11	36.73	-	36.84	-	63.74	53.74	-26.90	-
2	0.263	0.11	29.57	-	29.68	-	61.33	51.33	-31.65	-
3	0.463	0.12	26.36	-	26.48	-	56.65	46.65	-30.16	-
4	1.055	0.24	26.50	-	26.74	-	56.00	46.00	-29.26	-
5	2.633	0.30	31.21	-	31.51	-	56.00	46.00	-24.49	-
6	16.121	0.51	33.37	-	33.88	-	60.00	50.00	-26.12	-

- REMARKS:**
1. Q.P. and AV. are abbreviations of quasi-peak and average individually.
  2. "-": The Quasi-peak reading value also meets average limit and measurement with the average detector is unnecessary.
  3. The emission levels of other frequencies were very low against the limit.
  4. Margin value = Emission level - Limit value
  5. Correction factor = Insertion loss + Cable loss
  6. Emission Level = Correction Factor + Reading Value.

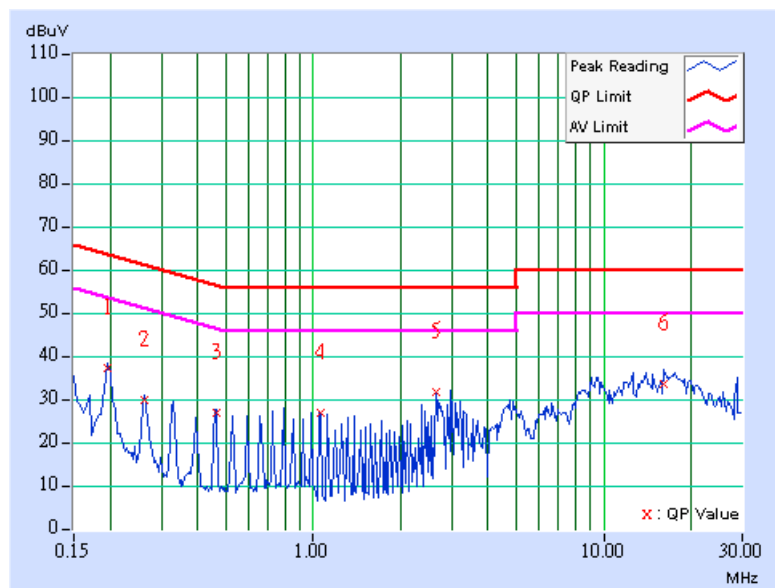





<b>EUT</b>	VA4200 Wi-Fi AP/Bridge	<b>MEASUREMENT DETAIL</b>	
<b>MODEL</b>	VA4200	<b>PHASE</b>	Line 1
<b>CHANNEL</b>	Channel 6	<b>6dB BANDWIDTH</b>	9 kHz
<b>MODULATION TYPE</b>	BPSK	<b>ENVIRONMENTAL CONDITIONS</b>	23deg. C, 65%RH, 991hPa
<b>TRANSFER RATE</b>	6Mbps	<b>INPUT POWER (SYSTEM)</b>	120Vac, 60 Hz
<b>TEST MODE</b>	2	<b>TESTED BY</b>	Gary Chang

No	Freq. [MHz]	Corr. Factor (dB)	Reading Value		Emission Level		Limit		Margin	
			[dB (uV)]		[dB (uV)]		[dB (uV)]		(dB)	
			Q.P.	AV.	Q.P.	AV.	Q.P.	AV.	Q.P.	AV.
1	0.197	0.11	37.46	-	37.57	-	63.74	53.74	-26.17	-
2	0.263	0.11	32.38	-	32.49	-	61.33	51.33	-28.84	-
3	0.396	0.11	28.39	-	28.50	-	57.93	47.93	-29.43	-
4	0.986	0.24	24.36	-	24.60	-	56.00	46.00	-31.40	-
5	2.695	0.31	30.57	-	30.88	-	56.00	46.00	-25.12	-
6	16.121	0.66	32.48	-	33.14	-	60.00	50.00	-26.86	-

- REMARKS:**
1. Q.P. and AV. are abbreviations of quasi-peak and average individually.
  2. "-": The Quasi-peak reading value also meets average limit and measurement with the average detector is unnecessary.
  3. The emission levels of other frequencies were very low against the limit.
  4. Margin value = Emission level - Limit value
  5. Correction factor = Insertion loss + Cable loss
  6. Emission Level = Correction Factor + Reading Value.

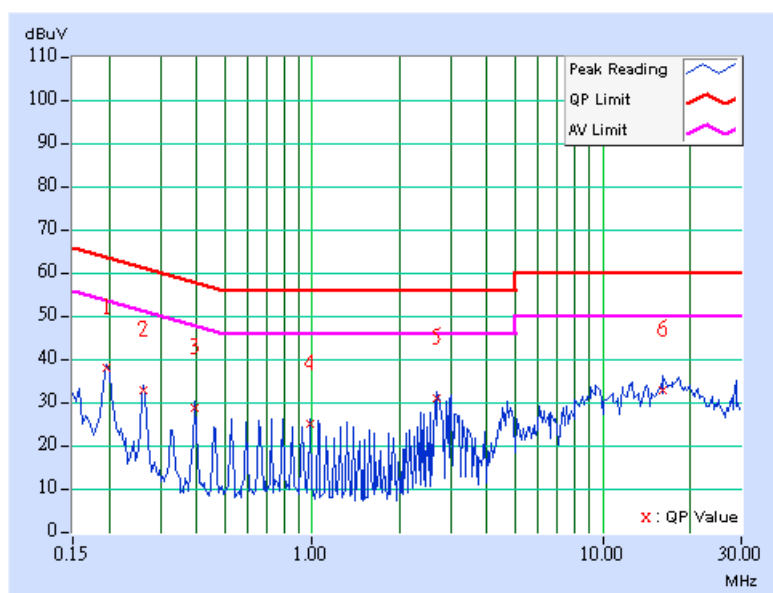



<b>EUT</b>	VA4200 Wi-Fi AP/Bridge	<b>MEASUREMENT DETAIL</b>	
<b>MODEL</b>	VA4200	<b>PHASE</b>	Line 2
<b>CHANNEL</b>	Channel 6	<b>6dB BANDWIDTH</b>	9 kHz
<b>MODULATION TYPE</b>	BPSK	<b>ENVIRONMENTAL CONDITIONS</b>	23deg. C, 65%RH, 991hPa
<b>TRANSFER RATE</b>	6Mbps	<b>INPUT POWER (SYSTEM)</b>	120Vac, 60 Hz
<b>TEST MODE</b>	2	<b>TESTED BY</b>	Gary Chang

No	Freq. [MHz]	Corr. Factor (dB)	Reading Value [dB (uV)]		Emission Level [dB (uV)]		Limit [dB (uV)]		Margin (dB)	
			Q.P.	AV.	Q.P.	AV.	Q.P.	AV.	Q.P.	AV.
			1	0.197	0.11	36.99	-	37.10	-	63.74
2	0.259	0.11	27.05	-	27.16	-	61.45	51.45	-34.29	-
3	0.459	0.12	27.40	-	27.52	-	56.72	46.72	-29.20	-
4	2.633	0.30	31.27	-	31.57	-	56.00	46.00	-24.43	-
5	4.934	0.40	28.65	-	29.05	-	56.00	46.00	-26.95	-
6	12.367	0.44	32.18	-	32.62	-	60.00	50.00	-27.38	-

- REMARKS:**
1. Q.P. and AV. are abbreviations of quasi-peak and average individually.
  2. "-": The Quasi-peak reading value also meets average limit and measurement with the average detector is unnecessary.
  3. The emission levels of other frequencies were very low against the limit.
  4. Margin value = Emission level - Limit value
  5. Correction factor = Insertion loss + Cable loss
  6. Emission Level = Correction Factor + Reading Value.

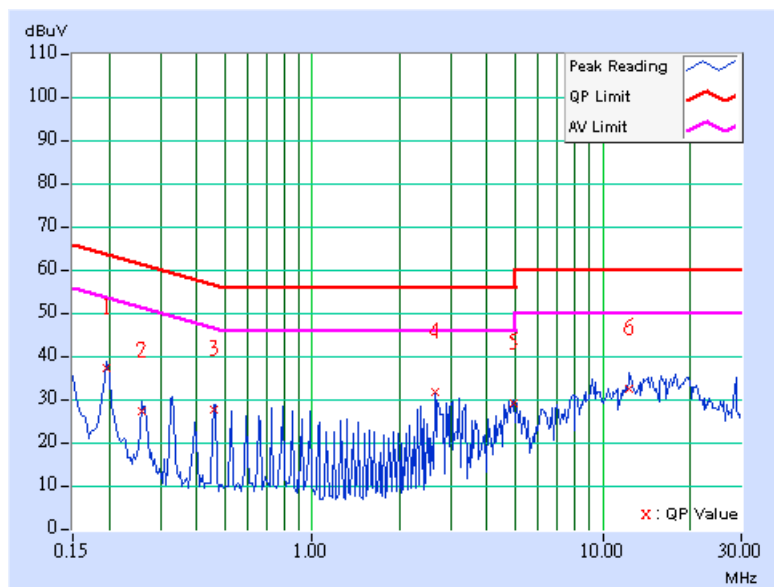



<b>EUT</b>	VA4200 Wi-Fi AP/Bridge	<b>MEASUREMENT DETAIL</b>	
<b>MODEL</b>	VA4200	<b>PHASE</b>	Line 1
<b>CHANNEL</b>	Channel 11	<b>6dB BANDWIDTH</b>	9 kHz
<b>MODULATION TYPE</b>	BPSK	<b>ENVIRONMENTAL CONDITIONS</b>	23deg. C, 65%RH, 991hPa
<b>TRANSFER RATE</b>	6Mbps	<b>INPUT POWER (SYSTEM)</b>	120Vac, 60 Hz
<b>TEST MODE</b>	2	<b>TESTED BY</b>	Gary Chang

No	Freq. [MHz]	Corr. Factor (dB)	Reading Value [dB (uV)]		Emission Level [dB (uV)]		Limit [dB (uV)]		Margin (dB)	
			Q.P.	AV.	Q.P.	AV.	Q.P.	AV.	Q.P.	AV.
			1	0.197	0.11	37.52	-	37.63	-	63.74
2	0.263	0.11	32.42	-	32.53	-	61.33	51.33	-28.80	-
3	0.392	0.11	27.40	-	27.51	-	58.02	48.02	-30.51	-
4	2.695	0.31	30.65	-	30.96	-	56.00	46.00	-25.04	-
5	9.219	0.52	27.43	-	27.95	-	60.00	50.00	-32.05	-
6	18.031	0.84	32.26	-	33.10	-	60.00	50.00	-26.90	-

- REMARKS:**
1. Q.P. and AV. are abbreviations of quasi-peak and average individually.
  2. "-": The Quasi-peak reading value also meets average limit and measurement with the average detector is unnecessary.
  3. The emission levels of other frequencies were very low against the limit.
  4. Margin value = Emission level - Limit value
  5. Correction factor = Insertion loss + Cable loss
  6. Emission Level = Correction Factor + Reading Value.

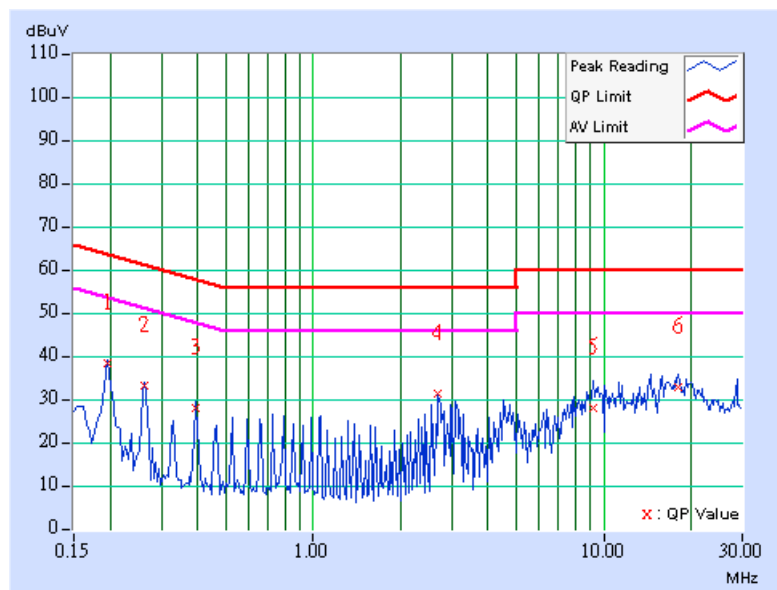



<b>EUT</b>	VA4200 Wi-Fi AP/Bridge	<b>MEASUREMENT DETAIL</b>	
<b>MODEL</b>	VA4200	<b>PHASE</b>	Line 2
<b>CHANNEL</b>	Channel 11	<b>6dB BANDWIDTH</b>	9 kHz
<b>MODULATION TYPE</b>	BPSK	<b>ENVIRONMENTAL CONDITIONS</b>	23deg. C, 65%RH, 991hPa
<b>TRANSFER RATE</b>	6Mbps	<b>INPUT POWER (SYSTEM)</b>	120Vac, 60 Hz
<b>TEST MODE</b>	2	<b>TESTED BY</b>	Gary Chang

No	Freq. [MHz]	Corr. Factor (dB)	Reading Value [dB (uV)]		Emission Level [dB (uV)]		Limit [dB (uV)]		Margin (dB)	
			Q.P.	AV.	Q.P.	AV.	Q.P.	AV.	Q.P.	AV.
			1	0.197	0.11	36.89	-	37.00	-	63.74
2	0.263	0.11	30.03	-	30.14	-	61.33	51.33	-31.19	-
3	0.459	0.12	27.42	-	27.54	-	56.72	46.72	-29.18	-
4	2.699	0.31	31.30	-	31.61	-	56.00	46.00	-24.39	-
5	4.871	0.40	28.71	-	29.11	-	56.00	46.00	-26.89	-
6	17.965	0.62	32.64	-	33.26	-	60.00	50.00	-26.74	-

- REMARKS:**
1. Q.P. and AV. are abbreviations of quasi-peak and average individually.
  2. "-": The Quasi-peak reading value also meets average limit and measurement with the average detector is unnecessary.
  3. The emission levels of other frequencies were very low against the limit.
  4. Margin value = Emission level - Limit value
  5. Correction factor = Insertion loss + Cable loss
  6. Emission Level = Correction Factor + Reading Value.

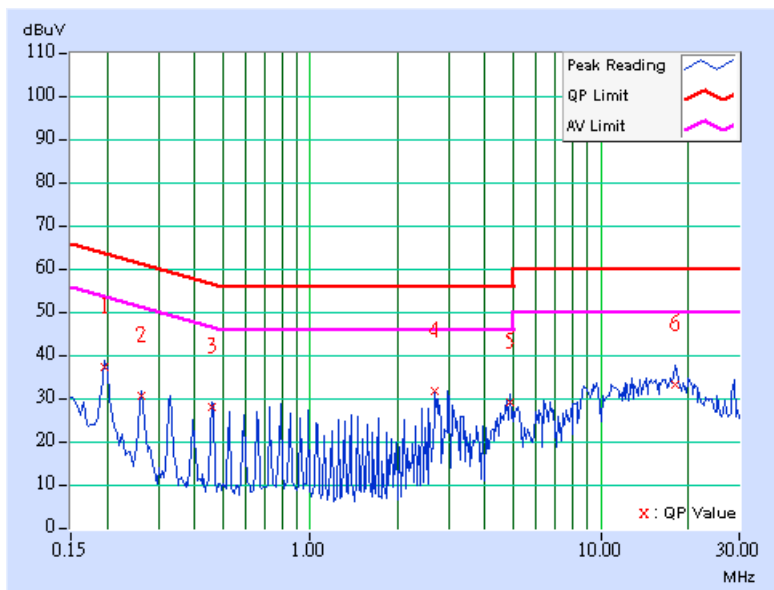



**Conducted Worst-Case Data (Power from POE)**

<b>EUT</b>	VA4200 Wi-Fi AP/Bridge	<b>MEASUREMENT DETAIL</b>	
<b>MODEL</b>	VA4200	<b>PHASE</b>	Line 1
<b>CHANNEL</b>	Channel 1	<b>6dB BANDWIDTH</b>	9 kHz
<b>MODULATION TYPE</b>	BPSK	<b>ENVIRONMENTAL CONDITIONS</b>	23deg. C, 65%RH, 991hPa
<b>TRANSFER RATE</b>	6Mbps	<b>INPUT POWER (SYSTEM)</b>	120Vac, 60 Hz
<b>TEST MODE</b>	3	<b>TESTED BY</b>	Gary Chang

No	Freq. [MHz]	Corr. Factor (dB)	Reading Value [dB (uV)]		Emission Level [dB (uV)]		Limit [dB (uV)]		Margin (dB)	
			Q.P.	AV.	Q.P.	AV.	Q.P.	AV.	Q.P.	AV.
			1	0.201	0.10	40.89	-	40.99	-	63.58
2	0.470	0.11	35.41	-	35.52	-	56.51	46.51	-20.99	-
3	2.023	0.20	36.19	-	36.39	-	56.00	46.00	-19.61	-
4	5.602	0.23	34.61	-	34.84	-	60.00	50.00	-25.16	-
5	19.191	0.74	41.48	-	42.22	-	60.00	50.00	-17.78	-
6	28.684	1.54	44.07	-	45.61	-	60.00	50.00	-14.39	-

- REMARKS:**
1. Q.P. and AV. are abbreviations of quasi-peak and average individually.
  2. "-": The Quasi-peak reading value also meets average limit and measurement with the average detector is unnecessary.
  3. The emission levels of other frequencies were very low against the limit.
  4. Margin value = Emission level - Limit value
  5. Correction factor = Insertion loss + Cable loss
  6. Emission Level = Correction Factor + Reading Value.

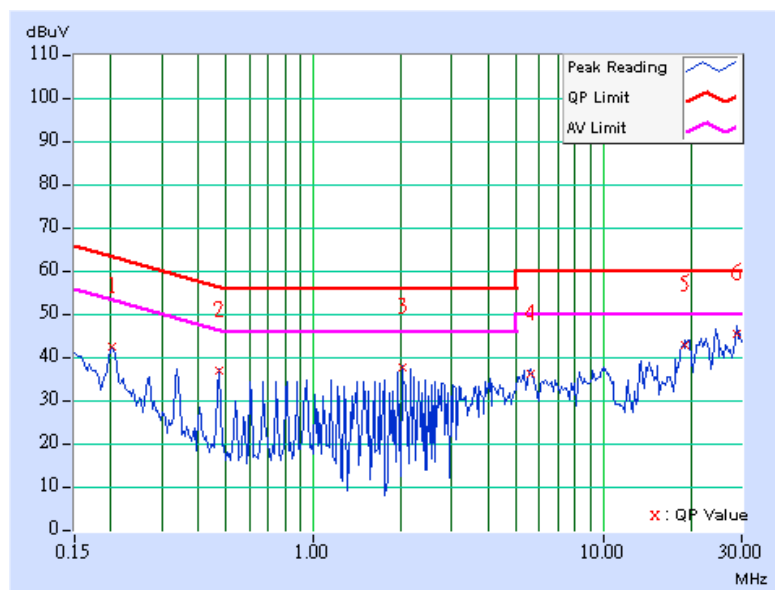



<b>EUT</b>	VA4200 Wi-Fi AP/Bridge	<b>MEASUREMENT DETAIL</b>	
<b>MODEL</b>	VA4200	<b>PHASE</b>	Line 2
<b>CHANNEL</b>	Channel 1	<b>6dB BANDWIDTH</b>	9 kHz
<b>MODULATION TYPE</b>	BPSK	<b>ENVIRONMENTAL CONDITIONS</b>	23deg. C, 65%RH, 991hPa
<b>TRANSFER RATE</b>	6Mbps	<b>INPUT POWER (SYSTEM)</b>	120Vac, 60 Hz
<b>TEST MODE</b>	3	<b>TESTED BY</b>	Gary Chang

No	Freq. [MHz]	Corr. Factor (dB)	Reading Value		Emission Level		Limit		Margin	
			[dB (uV)]		[dB (uV)]		[dB (uV)]		(dB)	
			Q.P.	AV.	Q.P.	AV.	Q.P.	AV.	Q.P.	AV.
1	0.201	0.10	41.42	-	41.52	-	63.58	53.58	-22.06	-
2	0.338	0.10	35.06	-	35.16	-	59.26	49.26	-24.10	-
3	0.470	0.11	34.32	-	34.43	-	56.51	46.51	-22.08	-
4	2.227	0.20	33.55	-	33.75	-	56.00	46.00	-22.25	-
5	13.418	0.47	38.32	-	38.79	-	60.00	50.00	-21.21	-
6	28.684	1.15	43.72	-	44.87	-	60.00	50.00	-15.13	-

- REMARKS:**
1. Q.P. and AV. are abbreviations of quasi-peak and average individually.
  2. "-": The Quasi-peak reading value also meets average limit and measurement with the average detector is unnecessary.
  3. The emission levels of other frequencies were very low against the limit.
  4. Margin value = Emission level - Limit value
  5. Correction factor = Insertion loss + Cable loss
  6. Emission Level = Correction Factor + Reading Value.

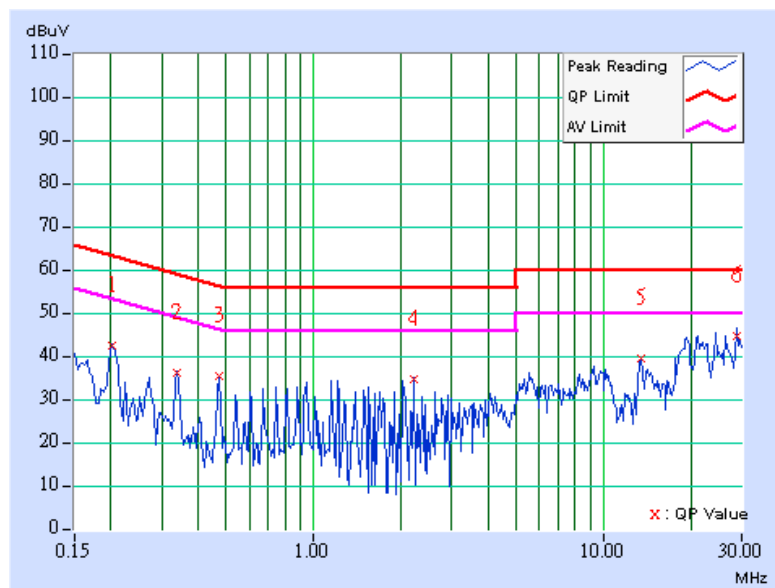



<b>EUT</b>	VA4200 Wi-Fi AP/Bridge	<b>MEASUREMENT DETAIL</b>	
<b>MODEL</b>	VA4200	<b>PHASE</b>	Line 1
<b>CHANNEL</b>	Channel 6	<b>6dB BANDWIDTH</b>	9 kHz
<b>MODULATION TYPE</b>	BPSK	<b>ENVIRONMENTAL CONDITIONS</b>	23deg. C, 65%RH, 991hPa
<b>TRANSFER RATE</b>	6Mbps	<b>INPUT POWER (SYSTEM)</b>	120Vac, 60 Hz
<b>TEST MODE</b>	3	<b>TESTED BY</b>	Gary Chang

No	Freq. [MHz]	Corr. Factor (dB)	Reading Value		Emission Level		Limit		Margin	
			[dB (uV)]		[dB (uV)]		[dB (uV)]		(dB)	
			Q.P.	AV.	Q.P.	AV.	Q.P.	AV.	Q.P.	AV.
1	0.201	0.10	39.81	-	39.91	-	63.58	53.58	-23.67	-
2	0.470	0.11	35.33	-	35.44	-	56.51	46.51	-21.07	-
3	1.957	0.20	35.57	-	35.77	-	56.00	46.00	-20.23	-
4	9.980	0.30	34.32	-	34.62	-	60.00	50.00	-25.38	-
5	19.410	0.75	42.13	-	42.88	-	60.00	50.00	-17.12	-
6	29.234	1.61	44.91	-	46.52	-	60.00	50.00	-13.48	-

- REMARKS:**
1. Q.P. and AV. are abbreviations of quasi-peak and average individually.
  2. "-": The Quasi-peak reading value also meets average limit and measurement with the average detector is unnecessary.
  3. The emission levels of other frequencies were very low against the limit.
  4. Margin value = Emission level - Limit value
  5. Correction factor = Insertion loss + Cable loss
  6. Emission Level = Correction Factor + Reading Value.

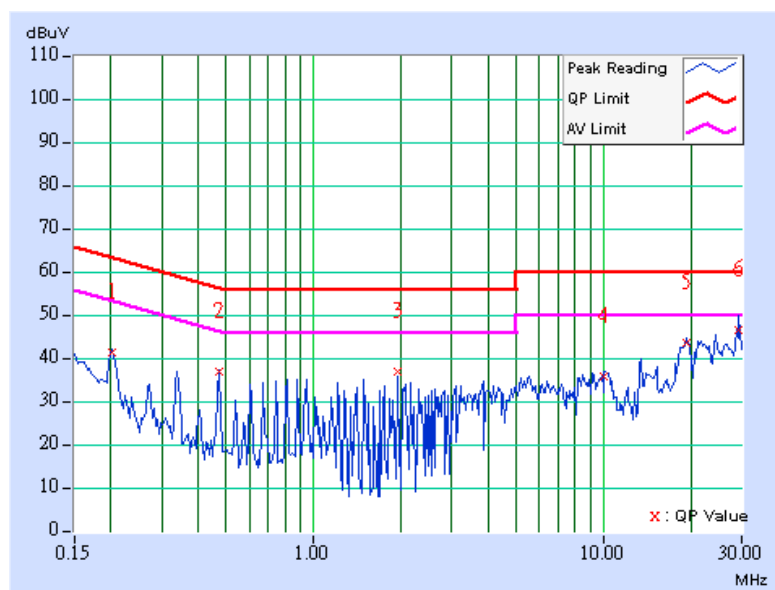



<b>EUT</b>	VA4200 Wi-Fi AP/Bridge	<b>MEASUREMENT DETAIL</b>	
<b>MODEL</b>	VA4200	<b>PHASE</b>	Line 2
<b>CHANNEL</b>	Channel 6	<b>6dB BANDWIDTH</b>	9 kHz
<b>MODULATION TYPE</b>	BPSK	<b>ENVIRONMENTAL CONDITIONS</b>	23deg. C, 65%RH, 991hPa
<b>TRANSFER RATE</b>	6Mbps	<b>INPUT POWER (SYSTEM)</b>	120Vac, 60 Hz
<b>TEST MODE</b>	3	<b>TESTED BY</b>	Gary Chang

No	Freq. [MHz]	Corr. Factor (dB)	Reading Value [dB (uV)]		Emission Level [dB (uV)]		Limit [dB (uV)]		Margin (dB)	
			Q.P.	AV.	Q.P.	AV.	Q.P.	AV.	Q.P.	AV.
			1	0.205	0.10	39.20	-	39.30	-	63.42
2	0.338	0.10	35.06	-	35.16	-	59.26	49.26	-24.10	-
3	0.470	0.11	34.04	-	34.15	-	56.51	46.51	-22.36	-
4	5.602	0.25	33.76	-	34.01	-	60.00	50.00	-25.99	-
5	19.762	0.79	40.21	-	41.00	-	60.00	50.00	-19.00	-
6	29.234	1.17	45.52	-	46.69	-	60.00	50.00	-13.31	-

- REMARKS:**
1. Q.P. and AV. are abbreviations of quasi-peak and average individually.
  2. "-": The Quasi-peak reading value also meets average limit and measurement with the average detector is unnecessary.
  3. The emission levels of other frequencies were very low against the limit.
  4. Margin value = Emission level - Limit value
  5. Correction factor = Insertion loss + Cable loss
  6. Emission Level = Correction Factor + Reading Value.

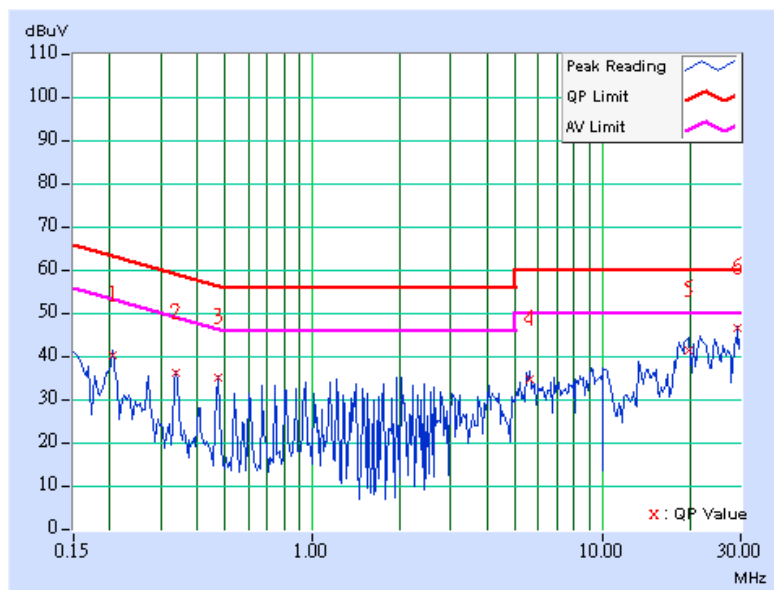





<b>EUT</b>	VA4200 Wi-Fi AP/Bridge	<b>MEASUREMENT DETAIL</b>	
<b>MODEL</b>	VA4200	<b>PHASE</b>	Line 1
<b>CHANNEL</b>	Channel 11	<b>6dB BANDWIDTH</b>	9 kHz
<b>MODULATION TYPE</b>	BPSK	<b>ENVIRONMENTAL CONDITIONS</b>	23deg. C, 65%RH, 991hPa
<b>TRANSFER RATE</b>	6Mbps	<b>INPUT POWER (SYSTEM)</b>	120Vac, 60 Hz
<b>TEST MODE</b>	3	<b>TESTED BY</b>	Gary Chang

No	Freq. [MHz]	Corr. Factor (dB)	Reading Value		Emission Level		Limit		Margin	
			[dB (uV)]		[dB (uV)]		[dB (uV)]		(dB)	
			Q.P.	AV.	Q.P.	AV.	Q.P.	AV.	Q.P.	AV.
1	0.205	0.10	38.88	-	38.98	-	63.42	53.42	-24.44	-
2	0.338	0.10	36.03	-	36.13	-	59.26	49.26	-23.13	-
3	0.470	0.11	35.39	-	35.50	-	56.51	46.51	-21.01	-
4	1.148	0.20	33.99	-	34.19	-	56.00	46.00	-21.81	-
5	19.406	0.75	42.90	-	43.65	-	60.00	50.00	-16.35	-
6	29.113	1.59	43.28	-	44.87	-	60.00	50.00	-15.13	-

- REMARKS:**
1. Q.P. and AV. are abbreviations of quasi-peak and average individually.
  2. "-": The Quasi-peak reading value also meets average limit and measurement with the average detector is unnecessary.
  3. The emission levels of other frequencies were very low against the limit.
  4. Margin value = Emission level - Limit value
  5. Correction factor = Insertion loss + Cable loss
  6. Emission Level = Correction Factor + Reading Value.

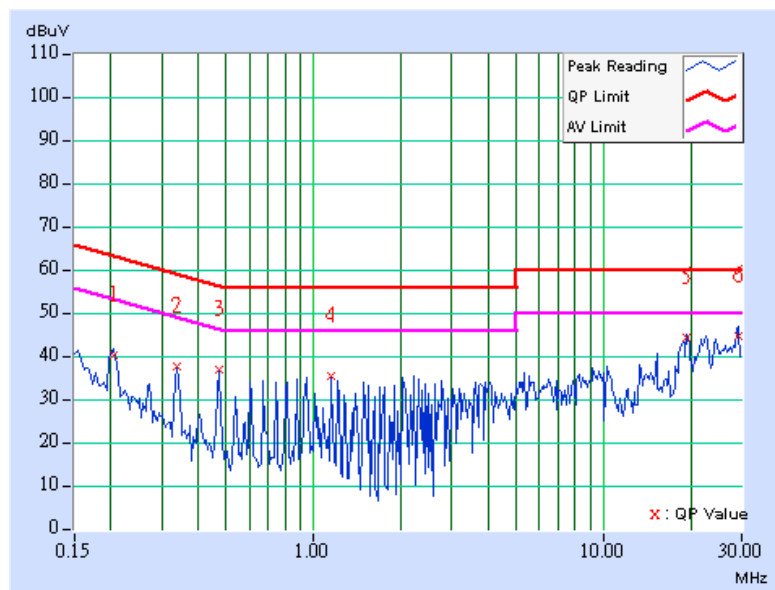



<b>EUT</b>	VA4200 Wi-Fi AP/Bridge	<b>MEASUREMENT DETAIL</b>	
<b>MODEL</b>	VA4200	<b>PHASE</b>	Line 2
<b>CHANNEL</b>	Channel 11	<b>6dB BANDWIDTH</b>	9 kHz
<b>MODULATION TYPE</b>	BPSK	<b>ENVIRONMENTAL CONDITIONS</b>	23deg. C, 65%RH, 991hPa
<b>TRANSFER RATE</b>	6Mbps	<b>INPUT POWER (SYSTEM)</b>	120Vac, 60 Hz
<b>TEST MODE</b>	3	<b>TESTED BY</b>	Gary Chang

No	Freq. [MHz]	Corr. Factor (dB)	Reading Value [dB (uV)]		Emission Level [dB (uV)]		Limit [dB (uV)]		Margin (dB)	
			Q.P.	AV.	Q.P.	AV.	Q.P.	AV.	Q.P.	AV.
			1	0.201	0.10	39.55	-	39.65	-	63.58
2	0.338	0.10	35.12	-	35.22	-	59.26	49.26	-24.04	-
3	0.470	0.11	34.28	-	34.39	-	56.51	46.51	-22.12	-
4	1.152	0.20	32.98	-	33.18	-	56.00	46.00	-22.82	-
5	18.484	0.71	41.07	-	41.78	-	60.00	50.00	-18.22	-
6	28.684	1.15	43.64	-	44.79	-	60.00	50.00	-15.21	-

- REMARKS:**
1. Q.P. and AV. are abbreviations of quasi-peak and average individually.
  2. "-": The Quasi-peak reading value also meets average limit and measurement with the average detector is unnecessary.
  3. The emission levels of other frequencies were very low against the limit.
  4. Margin value = Emission level - Limit value
  5. Correction factor = Insertion loss + Cable loss
  6. Emission Level = Correction Factor + Reading Value.

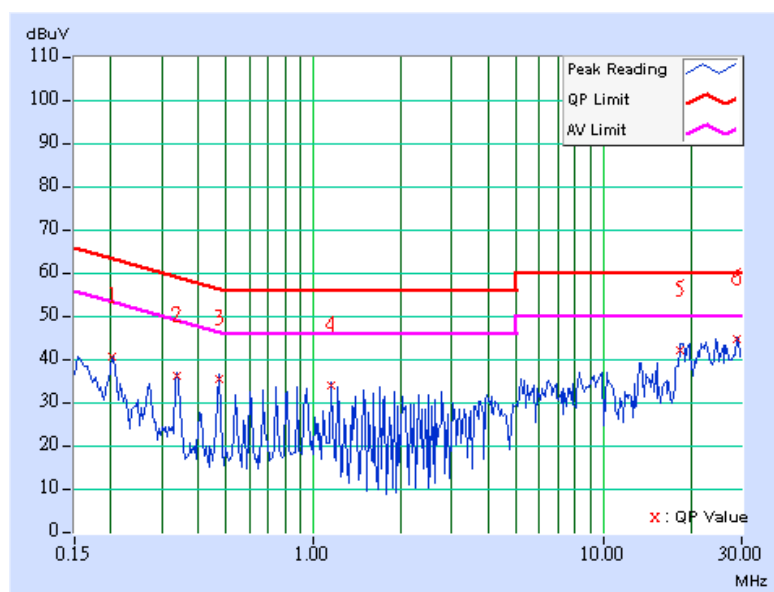



## 4.2 RADIATED EMISSION MEASUREMENT

### 4.2.1 LIMITS OF RADIATED EMISSION MEASUREMENT

Emissions radiated outside of the specified bands, shall be according to the general radiated limits in 15.209 as following:

Frequencies (MHz)	Field strength (microvolts/meter)	Measurement distance (meters)
0.009-0.490	2400/F(kHz)	300
0.490-1.705	24000/F(kHz)	30
1.705-30.0	30	30
30-88	100	3
88-216	150	3
216-960	200	3
Above 960	500	3

**NOTE:**

1. The lower limit shall apply at the transition frequencies.
2. Emission level (dBuV/m) = 20 log Emission level (uV/m).
3. As shown in 15.35(b), for frequencies above 1000MHz, the field strength limits are based on average detector, however, the peak field strength of any emission shall not exceed the maximum permitted average limits, specified above by more than 20dB under any condition of modulation.



## 4.2.2 TEST INSTRUMENTS

DESCRIPTION & MANUFACTURER	MODEL NO.	SERIAL NO.	CALIBRATED UNTIL
Test Receiver ROHDE & SCHWARZ	ESIB7	100188	Dec. 19, 2005
Spectrum Analyzer ROHDE & SCHWARZ	FSP40	100039	Nov. 21, 2005
BILOG Antenna SCHWARZBECK	VULB9168	9168-157	Jan. 22, 2006
HORN Antenna SCHWARZBECK	BBHA 9120 D	9120D-407	Jan. 16, 2006
HORN Antenna SCHWARZBECK	BBHA 9170	BBHA 9170241	Feb. 23, 2006
Preamplifier Agilent	8449B	3008A01961	Nov. 09, 2005
Preamplifier Agilent	8447D	2944A10629	Nov. 09, 2005
RF signal cable HUBER+SUHNER	SUCOFLEX 104	218182/4	Feb. 17, 2006
RF signal cable HUBER+SUHNER	SUCOFLEX 104	218194/4	Feb. 17, 2006
Software ADT.	ADT_Radiated_V5.14	NA	NA
Antenna Tower ADT.	AT100	AT93021702	NA
Turn Table ADT.	TT100.	TT93021702	NA
Controller ADT.	SC100.	SC93021702	NA

- NOTE:**
1. The calibration interval of the above test instruments is 12 months and the calibrations are traceable to NML/ROC and NIST/USA.
  2. The test was performed in HwaYa Chamber 1.
  3. The horn antenna and HP preamplifier (model: 8449B) are used only for the measurement of emission frequency above 1GHz if tested.
  4. The IC Site Registration No. is IC4924-2.



#### 4.2.3 TEST PROCEDURES

- a. The EUT was placed on the top of a rotating table 0.8 meters above the ground at a 3 meter semi-anechoic chamber. The table was rotated 360 degrees to determine the position of the highest radiation.
- b. The EUT was set 3 meters away from the interference-receiving antenna, which was mounted on the top of a variable-height antenna tower.
- c. The antenna is a broadband antenna, and its height is varied from one meter to four meters above the ground to determine the maximum value of the field strength. Both horizontal and vertical polarizations of the antenna are set to make the measurement.
- d. For each suspected emission, the EUT was arranged to its worst case and then the antenna was tuned to heights from 1 meter to 4 meters and the rotatable table was turned from 0 degrees to 360 degrees to find the maximum reading.
- e. The test-receiver system was set to Peak Detect Function and Specified Bandwidth with Maximum Hold Mode.
- f. If the emission level of the EUT in peak mode was lower than the limit specified, then testing could be stopped and the peak values of the EUT would be reported. Otherwise the emissions would be re-tested one by one using peak, quasi-peak or average method as specified and then reported in a data sheet.

**NOTE:**

1. The resolution bandwidth and video bandwidth of test receiver/spectrum analyzer is 120kHz for Quasi-peak detection at frequency below 1GHz.
2. The resolution bandwidth and video bandwidth of test receiver/spectrum analyzer is 1 MHz for Peak detection (PK) at frequency above 1GHz.
3. The resolution bandwidth of test receiver/spectrum analyzer is 1 MHz and the video bandwidth is 10 Hz for Average detection (AV) at frequency above 1GHz.

#### 4.2.4 DEVIATION FROM TEST STANDARD

No deviation

#### 4.2.5 TEST SETUP

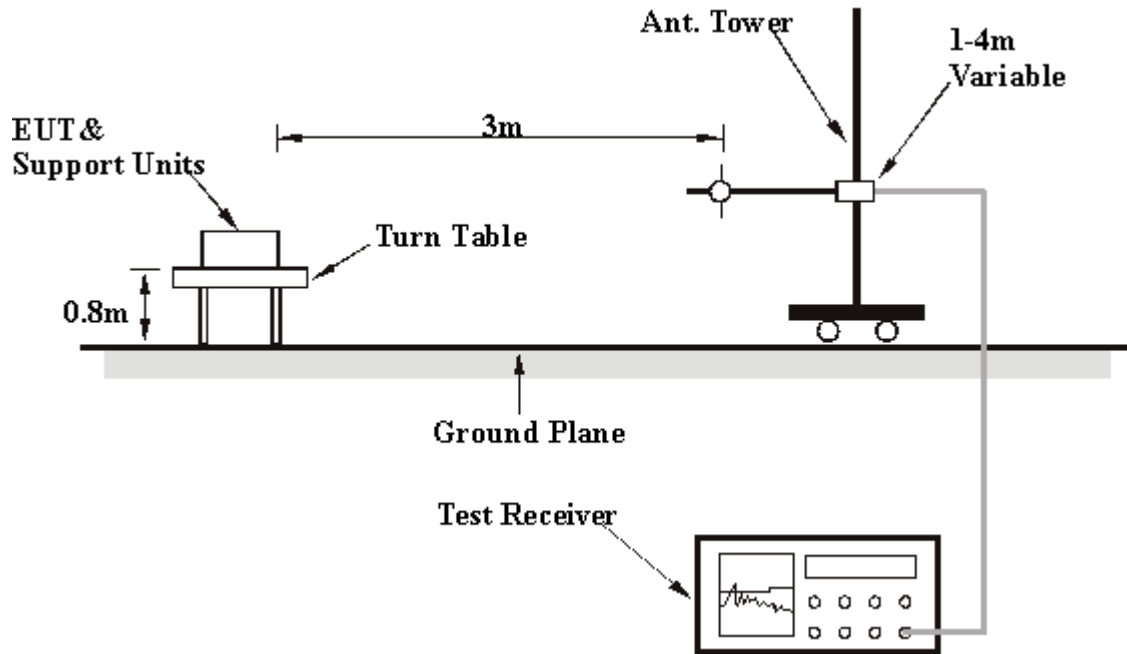

For the actual test configuration, please refer to the related item – Photographs of the Test Configuration.

#### 4.2.6 EUT OPERATING CONDITIONS

Same as 4.1.6



## 4.2.7 TEST RESULTS

**Below 1GHz Worst-Case Data (Power from AC Adapter: RHE-120150-7)**

<b>EUT</b>	VA4200 Wi-Fi AP/Bridge	<b>MEASUREMENT DETAIL</b>	
<b>MODEL</b>	VA4200	<b>FREQUENCY RANGE</b>	Below 1000MHz
<b>CHANNEL</b>	Channel 1	<b>DETECTOR FUNCTION</b>	Quasi-Peak
<b>MODULATION TYPE</b>	BPSK	<b>ENVIRONMENTAL CONDITIONS</b>	21deg. C, 70%RH, 991hPa
<b>TRANSFER RATE</b>	6Mbps	<b>INPUT POWER (SYSTEM)</b>	120Vac, 60 Hz
<b>TEST MODE</b>	1	<b>TESTED BY</b>	Match Tsui

**ANTENNA POLARITY & TEST DISTANCE: HORIZONTAL AT 3 M**

No.	Freq. (MHz)	Emission Level (dBuV/m)	Limit (dBuV/m)	Margin (dB)	Antenna Height (m)	Table Angle (Degree)	Raw Value (dBuV)	Correction Factor (dB/m)
1	113.59	35.85 QP	43.50	-7.65	1.50 H	283	23.71	12.14
2	166.07	35.38 QP	43.50	-8.12	1.50 H	271	21.32	14.07
3	199.12	40.60 QP	43.50	-2.90	1.00 H	31	29.40	11.20
4	249.66	44.22 QP	46.00	-1.78	1.25 H	1	31.14	13.08
5	300.20	35.93 QP	46.00	-10.07	1.00 H	106	21.59	14.33
6	366.29	35.07 QP	46.00	-10.93	1.00 H	28	19.22	15.84
7	399.34	42.66 QP	46.00	-3.34	1.00 H	319	26.04	16.62
8	432.38	36.97 QP	46.00	-9.03	1.00 H	28	19.51	17.46
9	467.37	36.76 QP	46.00	-9.24	1.75 H	64	18.61	18.15
10	533.47	37.38 QP	46.00	-8.62	1.25 H	331	18.10	19.27
11	599.56	36.09 QP	46.00	-9.91	1.50 H	178	15.21	20.88
12	667.60	37.31 QP	46.00	-8.69	1.00 H	1	15.49	21.82
13	799.78	39.59 QP	46.00	-6.41	1.00 H	28	15.89	23.70
14	900.86	35.53 QP	46.00	-10.47	1.00 H	304	10.41	25.11
15	933.91	43.22 QP	46.00	-2.78	1.50 H	349	17.77	25.45

- REMARKS:**
1. Emission level(dBuV/m)=Raw Value(dBuV) + Correction Factor(dB/m)
  2. Correction Factor(dB/m) = Antenna Factor (dB/m) + Cable Factor (dB)
  3. The other emission levels were very low against the limit.
  4. Margin value = Emission level – Limit value



<b>EUT</b>	VA4200 Wi-Fi AP/Bridge	<b>MEASUREMENT DETAIL</b>	
<b>MODEL</b>	VA4200	<b>FREQUENCY RANGE</b>	Below 1000MHz
<b>CHANNEL</b>	Channel 1	<b>DETECTOR FUNCTION</b>	Quasi-Peak
<b>MODULATION TYPE</b>	BPSK	<b>ENVIRONMENTAL CONDITIONS</b>	21deg. C, 70%RH, 991hPa
<b>TRANSFER RATE</b>	6Mbps	<b>INPUT POWER (SYSTEM)</b>	120Vac, 60 Hz
<b>TEST MODE</b>	1	<b>TESTED BY</b>	Match Tsui

### ANTENNA POLARITY & TEST DISTANCE: VERTICAL AT 3 M

No.	Freq. (MHz)	Emission Level (dBuV/m)	Limit (dBuV/m)	Margin (dB)	Antenna Height (m)	Table Angle (Degree)	Raw Value (dBuV)	Correction Factor (dB/m)
1	31.94	32.22 QP	40.00	-7.78	1.25 V	61	18.54	13.68
2	64.99	34.36 QP	40.00	-5.64	1.00 V	115	21.46	12.90
3	105.81	38.21 QP	43.50	-5.29	1.00 V	73	26.87	11.34
4	166.07	41.61 QP	43.50	-1.89	1.00 V	340	27.54	14.07
5	199.12	36.84 QP	43.50	-6.66	1.25 V	169	25.64	11.20
6	249.66	40.72 QP	46.00	-5.28	1.50 V	22	27.64	13.08
7	399.34	37.80 QP	46.00	-8.20	1.25 V	241	21.18	16.62
8	455.71	36.74 QP	46.00	-9.26	1.00 V	352	18.75	17.99
9	533.47	36.30 QP	46.00	-9.70	1.00 V	355	17.03	19.27
10	599.56	37.04 QP	46.00	-8.96	1.50 V	10	16.16	20.88
11	667.60	35.76 QP	46.00	-10.24	1.50 V	25	13.94	21.82
12	733.69	35.20 QP	46.00	-10.80	1.25 V	340	12.17	23.03
13	933.91	43.10 QP	46.00	-2.90	1.00 V	304	17.66	25.45

- REMARKS:**
1. Emission level(dBuV/m)=Raw Value(dBuV) + Correction Factor(dB/m)
  2. Correction Factor(dB/m) = Antenna Factor (dB/m) + Cable Factor (dB)
  3. The other emission levels were very low against the limit.
  4. Margin value = Emission level – Limit value



**Below 1GHz Worst-Case Data (Power from AC Adapter: NU20-5120200-I2)**

<b>EUT</b>	VA4200 Wi-Fi AP/Bridge	<b>MEASUREMENT DETAIL</b>	
<b>MODEL</b>	VA4200	<b>FREQUENCY RANGE</b>	Below 1000MHz
<b>CHANNEL</b>	Channel 1	<b>DETECTOR FUNCTION</b>	Quasi-Peak
<b>MODULATION TYPE</b>	BPSK	<b>ENVIRONMENTAL CONDITIONS</b>	25deg. C, 68%RH, 991hPa
<b>TRANSFER RATE</b>	6Mbps	<b>INPUT POWER (SYSTEM)</b>	120Vac, 60 Hz
<b>TEST MODE</b>	2	<b>TESTED BY</b>	Match Tsui

**ANTENNA POLARITY & TEST DISTANCE: HORIZONTAL AT 3 M**

No.	Freq. (MHz)	Emission Level (dBuV/m)	Limit (dBuV/m)	Margin (dB)	Antenna Height (m)	Table Angle (Degree)	Raw Value (dBuV)	Correction Factor (dB/m)
1	105.81	40.44 QP	43.50	-3.06	2.00 H	64	29.10	11.34
2	166.07	41.78 QP	43.50	-1.72	2.00 H	61	27.71	14.07
3	199.12	35.90 QP	43.50	-7.60	1.50 H	4	24.70	11.20
4	249.66	44.06 QP	46.00	-1.94	1.00 H	184	30.98	13.08
5	333.25	38.27 QP	46.00	-7.73	1.00 H	322	23.19	15.08
6	366.29	38.71 QP	46.00	-7.29	1.00 H	295	22.86	15.84
7	399.34	44.10 QP	46.00	-1.90	1.00 H	298	27.48	16.62
8	533.47	37.22 QP	46.00	-8.78	1.50 H	19	17.95	19.27
9	599.56	37.02 QP	46.00	-8.98	1.50 H	328	16.13	20.88
10	667.60	39.62 QP	46.00	-6.38	1.00 H	7	17.80	21.82
11	799.78	40.11 QP	46.00	-5.89	1.00 H	1	16.41	23.70
12	900.86	36.15 QP	46.00	-9.85	1.50 H	238	11.04	25.11
13	933.91	42.40 QP	46.00	-3.60	1.50 H	355	16.95	25.45

**ANTENNA POLARITY & TEST DISTANCE: VERTICAL AT 3 M**

No.	Freq. (MHz)	Emission Level (dBuV/m)	Limit (dBuV/m)	Margin (dB)	Antenna Height (m)	Table Angle (Degree)	Raw Value (dBuV)	Correction Factor (dB/m)
1	59.16	33.63 QP	40.00	-6.37	1.00 V	106	20.09	13.54
2	105.81	35.59 QP	43.50	-7.91	1.00 V	253	24.24	11.34
3	166.07	32.27 QP	43.50	-11.23	1.00 V	85	18.20	14.07
4	249.66	34.62 QP	46.00	-11.38	1.50 V	139	21.55	13.08
5	399.34	39.63 QP	46.00	-6.37	2.00 V	316	23.01	16.62
6	533.47	34.89 QP	46.00	-11.11	1.50 V	295	15.62	19.27
7	599.56	33.82 QP	46.00	-12.18	1.00 V	211	12.93	20.88
8	667.60	38.58 QP	46.00	-7.42	1.50 V	337	16.76	21.82
9	799.78	34.23 QP	46.00	-11.77	1.50 V	106	10.53	23.70
10	933.91	41.47 QP	46.00	-4.53	1.00 V	316	16.03	25.45

- REMARKS:**
1. Emission level(dBuV/m)=Raw Value(dBuV) + Correction Factor(dB/m)
  2. Correction Factor(dB/m) = Antenna Factor (dB/m) + Cable Factor (dB)
  3. The other emission levels were very low against the limit.
  4. Margin value = Emission level – Limit value



### Below 1GHz Worst-Case Data (Power from POE)

<b>EUT</b>	VA4200 Wi-Fi AP/Bridge	<b>MEASUREMENT DETAIL</b>	
<b>MODEL</b>	VA4200	<b>FREQUENCY RANGE</b>	Below 1000MHz
<b>CHANNEL</b>	Channel 1	<b>DETECTOR FUNCTION</b>	Quasi-Peak
<b>MODULATION TYPE</b>	BPSK	<b>ENVIRONMENTAL CONDITIONS</b>	21deg. C, 70%RH, 991hPa
<b>TRANSFER RATE</b>	6Mbps	<b>INPUT POWER (SYSTEM)</b>	120Vac, 60 Hz
<b>TEST MODE</b>	3	<b>TESTED BY</b>	Match Tsui

#### ANTENNA POLARITY & TEST DISTANCE: HORIZONTAL AT 3 M

No.	Freq. (MHz)	Emission Level (dBuV/m)	Limit (dBuV/m)	Margin (dB)	Antenna Height (m)	Table Angle (Degree)	Raw Value (dBuV)	Correction Factor (dB/m)
1	43.61	36.98 QP	40.00	-3.02	1.50 H	52	21.95	15.03
2	94.15	36.83 QP	43.50	-6.67	1.75 H	10	26.56	10.28
3	142.75	38.56 QP	43.50	-4.94	1.00 H	7	24.29	14.27
4	199.12	35.03 QP	43.50	-8.47	1.00 H	298	23.83	11.20
5	249.66	44.25 QP	46.00	-1.75	1.00 H	343	31.17	13.08
6	300.20	37.29 QP	46.00	-8.71	1.00 H	319	22.96	14.33
7	333.25	36.75 QP	46.00	-9.25	1.00 H	334	21.67	15.08
8	399.34	40.61 QP	46.00	-5.39	1.00 H	166	23.99	16.62
9	500.42	38.46 QP	46.00	-7.54	1.50 H	355	19.87	18.59
10	533.47	36.58 QP	46.00	-9.42	1.50 H	343	17.31	19.27
11	599.56	38.13 QP	46.00	-7.87	1.50 H	121	17.25	20.88
12	667.60	38.53 QP	46.00	-7.47	1.25 H	10	16.71	21.82
13	799.78	37.02 QP	46.00	-8.98	1.00 H	1	13.32	23.70
14	933.91	41.97 QP	46.00	-4.03	1.50 H	334	16.52	25.45

#### ANTENNA POLARITY & TEST DISTANCE: VERTICAL AT 3 M

No.	Freq. (MHz)	Emission Level (dBuV/m)	Limit (dBuV/m)	Margin (dB)	Antenna Height (m)	Table Angle (Degree)	Raw Value (dBuV)	Correction Factor (dB/m)
1	43.61	38.26 QP	40.00	-1.74	1.00 V	31	23.23	15.03
2	105.81	41.50 QP	43.50	-2.00	1.00 V	244	30.16	11.34
3	142.75	38.34 QP	43.50	-5.16	1.00 V	58	24.06	14.27
4	249.66	41.61 QP	46.00	-4.39	1.00 V	52	28.53	13.08
5	399.34	37.47 QP	46.00	-8.53	1.75 V	307	20.85	16.62
6	500.42	38.42 QP	46.00	-7.58	1.00 V	346	19.83	18.59
7	599.56	36.87 QP	46.00	-9.13	1.50 V	4	15.98	20.88
8	667.60	36.85 QP	46.00	-9.15	1.00 V	274	15.03	21.82
9	799.78	36.19 QP	46.00	-9.81	1.50 V	262	12.49	23.70
10	933.91	44.35 QP	46.00	-1.65	1.00 V	301	18.90	25.45

- REMARKS:**
1. Emission level(dBuV/m)=Raw Value(dBuV) + Correction Factor(dB/m)
  2. Correction Factor(dB/m) = Antenna Factor (dB/m) + Cable Factor (dB)
  3. The other emission levels were very low against the limit.
  4. Margin value = Emission level – Limit value

**802.11b DSSS modulation**

<b>EUT</b>	VA4200 Wi-Fi AP/Bridge	<b>MEASUREMENT DETAIL</b>	
<b>MODEL</b>	VA4200	<b>FREQUENCY RANGE</b>	1 ~ 25GHz
<b>CHANNEL</b>	Channel 1	<b>DETECTOR FUNCTION</b>	Peak(PK) Average (AV)
<b>MODULATION TYPE</b>	CCK	<b>ENVIRONMENTAL CONDITIONS</b>	25deg. C, 68%RH, 991hPa
<b>TRANSFER RATE</b>	11Mbps	<b>INPUT POWER (SYSTEM)</b>	120Vac, 60 Hz
<b>TESTED BY</b>	Match Tsui		

**ANTENNA POLARITY & TEST DISTANCE: HORIZONTAL AT 3 M**

No.	Freq. (MHz)	Emission Level (dBuV/m)	Limit (dBuV/m)	Margin (dB)	Antenna Height (m)	Table Angle (Degree)	Raw Value (dBuV)	Correction Factor (dB/m)
1	1066.00	44.37 PK	74.00	-29.63	1.35 H	310	17.61	26.76
1	1066.00	39.84 AV	54.00	-14.16	1.35 H	310	13.08	26.76
2	2016.00	45.36 PK	74.00	-28.64	1.00 H	109	15.95	29.41
2	2016.00	41.26 AV	54.00	-12.74	1.00 H	109	11.85	29.41
3	2386.00	58.95 PK	74.00	-15.05	1.32 H	51	27.99	30.96
3	2386.00	48.87 AV	54.00	-5.13	1.32 H	51	17.91	30.96
4	*2412.00	105.66 PK			1.32 H	51	74.60	31.06
4	*2412.00	99.35 AV			1.32 H	51	68.29	31.06
5	4824.00	54.00 PK	74.00	-20.00	1.27 H	212	17.57	36.43
5	4824.00	42.92 AV	54.00	-11.08	1.27 H	212	6.49	36.43
6	7236.00	52.03 PK	74.00	-21.97	1.26 H	223	9.77	42.25
6	7236.00	39.77 AV	54.00	-14.23	1.26 H	223	-2.49	42.25

- REMARKS:**
1. Emission level(dBuV/m)=Raw Value(dBuV) + Correction Factor(dB/m)
  2. Correction Factor(dB/m) = Antenna Factor (dB/m) + Cable Factor (dB)
  3. The other emission levels were very low against the limit.
  4. Margin value = Emission level – Limit value.
  5. The limit value is defined as per 15.247
  6. “ \* “ : Fundamental frequency



<b>EUT</b>	VA4200 Wi-Fi AP/Bridge	<b>MEASUREMENT DETAIL</b>	
<b>MODEL</b>	VA4200	<b>FREQUENCY RANGE</b>	1 ~ 25GHz
<b>CHANNEL</b>	Channel 1	<b>DETECTOR FUNCTION</b>	Peak(PK) Average (AV)
<b>MODULATION TYPE</b>	CCK	<b>ENVIRONMENTAL CONDITIONS</b>	25deg. C, 68%RH, 991hPa
<b>TRANSFER RATE</b>	11Mbps	<b>INPUT POWER (SYSTEM)</b>	120Vac, 60 Hz
<b>TESTED BY</b>	Match Tsui		

### ANTENNA POLARITY & TEST DISTANCE: VERTICAL AT 3 M

No.	Freq. (MHz)	Emission Level (dBuV/m)	Limit (dBuV/m)	Margin (dB)	Antenna Height (m)	Table Angle (Degree)	Raw Value (dBuV)	Correction Factor (dB/m)
1	1066.00	47.50 PK	74.00	-26.50	1.06 V	277	20.74	26.76
1	1066.00	44.17 AV	54.00	-9.83	1.06 V	277	17.41	26.76
2	2016.00	45.79 PK	74.00	-28.21	1.00 V	25	16.38	29.41
2	2016.00	42.83 AV	54.00	-11.17	1.00 V	25	13.42	29.41
3	2360.00	58.61 PK	74.00	-15.39	1.16 V	337	27.76	30.85
3	2360.00	49.18 AV	54.00	-4.82	1.16 V	337	18.33	30.85
4	2386.00	63.37 PK	74.00	-10.63	1.11 V	128	32.41	30.96
4	2386.00	52.15 AV	54.00	-1.85	1.11 V	128	21.19	30.96
5	*2412.00	112.96 PK			1.11 V	128	81.90	31.06
5	*2412.00	106.21 AV			1.11 V	128	75.15	31.06
6	2688.00	48.59 PK	74.00	-25.41	1.18 V	35	16.81	31.78
6	2688.00	45.50 AV	54.00	-8.50	1.18 V	35	13.72	31.78
7	4824.00	58.46 PK	74.00	-15.54	1.00 V	213	22.03	36.43
7	4824.00	48.41 AV	54.00	-5.59	1.00 V	213	11.98	36.43
8	7236.00	54.48 PK	74.00	-19.52	1.20 V	216	12.22	42.25
8	7236.00	45.10 AV	54.00	-8.90	1.20 V	216	2.84	42.25

- REMARKS:**
1. Emission level(dBuV/m)=Raw Value(dBuV) + Correction Factor(dB/m)
  2. Correction Factor(dB/m) = Antenna Factor (dB/m) + Cable Factor (dB)
  3. The other emission levels were very low against the limit.
  4. Margin value = Emission level – Limit value.
  5. The limit value is defined as per 15.247
  6. “ \* “ : Fundamental frequency



<b>EUT</b>	VA4200 Wi-Fi AP/Bridge	<b>MEASUREMENT DETAIL</b>	
<b>MODEL</b>	VA4200	<b>FREQUENCY RANGE</b>	1 ~ 25GHz
<b>CHANNEL</b>	Channel 6	<b>DETECTOR FUNCTION</b>	Peak(PK) Average (AV)
<b>MODULATION TYPE</b>	CCK	<b>ENVIRONMENTAL CONDITIONS</b>	25deg. C, 68%RH, 991hPa
<b>TRANSFER RATE</b>	11Mbps	<b>INPUT POWER (SYSTEM)</b>	120Vac, 60 Hz
<b>TESTED BY</b>	Match Tsui		

### ANTENNA POLARITY & TEST DISTANCE: HORIZONTAL AT 3 M

No.	Freq. (MHz)	Emission Level (dBuV/m)	Limit (dBuV/m)	Margin (dB)	Antenna Height (m)	Table Angle (Degree)	Raw Value (dBuV)	Correction Factor (dB/m)
1	1066.00	43.97 PK	74.00	-30.03	1.37 H	75	17.21	26.76
1	1066.00	38.89 AV	54.00	-15.11	1.37 H	75	12.13	26.76
2	2016.00	48.44 PK	74.00	-25.56	1.33 H	134	19.03	29.41
2	2016.00	45.62 AV	54.00	-8.38	1.33 H	134	16.21	29.41
3	*2437.00	107.41 PK			1.26 H	49	76.24	31.17
3	*2437.00	100.02 AV			1.26 H	49	68.85	31.17
4	4874.00	53.01 PK	74.00	-20.99	1.12 H	212	16.47	36.54
4	4874.00	42.10 AV	54.00	-11.90	1.12 H	212	5.56	36.54

### ANTENNA POLARITY & TEST DISTANCE: VERTICAL AT 3 M

No.	Freq. (MHz)	Emission Level (dBuV/m)	Limit (dBuV/m)	Margin (dB)	Antenna Height (m)	Table Angle (Degree)	Raw Value (dBuV)	Correction Factor (dB/m)
1	1066.00	49.72 PK	74.00	-24.28	1.06 V	280	22.96	26.76
1	1066.00	45.53 AV	54.00	-8.47	1.06 V	280	18.77	26.76
2	2016.00	50.24 PK	74.00	-23.76	1.35 V	21	20.83	29.41
2	2016.00	48.47 AV	54.00	-5.53	1.35 V	21	19.06	29.41
3	2360.00	61.04 PK	74.00	-12.96	1.17 V	335	30.19	30.85
3	2360.00	50.43 AV	54.00	-3.57	1.17 V	335	19.58	30.85
4	*2437.00	116.01 PK			1.07 V	82	84.84	31.17
4	*2437.00	108.40 AV			1.07 V	82	77.23	31.17
5	2688.00	48.54 PK	74.00	-25.46	1.19 V	36	16.76	31.78
5	2688.00	45.30 AV	54.00	-8.70	1.19 V	36	13.52	31.78
6	4874.00	58.47 PK	74.00	-15.53	1.00 V	216	21.93	36.54
6	4874.00	48.37 AV	54.00	-5.63	1.00 V	216	11.83	36.54
7	7311.00	54.65 PK	74.00	-19.35	1.24 V	108	12.19	42.46
7	7311.00	45.39 AV	54.00	-8.61	1.24 V	108	2.93	42.46

- REMARKS:**
1. Emission level(dBuV/m)=Raw Value(dBuV) + Correction Factor(dB/m)
  2. Correction Factor(dB/m) = Antenna Factor (dB/m) + Cable Factor (dB)
  3. The other emission levels were very low against the limit.
  4. Margin value = Emission level – Limit value.
  5. The limit value is defined as per 15.247
  6. “ \* “ : Fundamental frequency



<b>EUT</b>	VA4200 Wi-Fi AP/Bridge	<b>MEASUREMENT DETAIL</b>	
<b>MODEL</b>	VA4200	<b>FREQUENCY RANGE</b>	1 ~ 25GHz
<b>CHANNEL</b>	Channel 11	<b>DETECTOR FUNCTION</b>	Peak(PK) Average (AV)
<b>MODULATION TYPE</b>	CCK	<b>ENVIRONMENTAL CONDITIONS</b>	25deg. C, 68%RH, 991hPa
<b>TRANSFER RATE</b>	11Mbps	<b>INPUT POWER (SYSTEM)</b>	120Vac, 60 Hz
<b>TESTED BY</b>	Match Tsui		

### ANTENNA POLARITY & TEST DISTANCE: HORIZONTAL AT 3 M

No.	Freq. (MHz)	Emission Level (dBuV/m)	Limit (dBuV/m)	Margin (dB)	Antenna Height (m)	Table Angle (Degree)	Raw Value (dBuV)	Correction Factor (dB/m)
1	1066.00	45.03 PK	74.00	-28.97	1.37 H	308	18.27	26.76
1	1066.00	42.18 AV	54.00	-11.82	1.37 H	308	15.42	26.76
2	2016.00	49.94 PK	74.00	-24.06	1.00 H	110	20.53	29.41
2	2016.00	46.96 AV	54.00	-7.04	1.00 H	110	17.55	29.41
3	*2462.00	105.19 PK			1.31 H	99	73.91	31.28
3	*2462.00	98.73 AV			1.31 H	99	67.45	31.28
4	2486.00	55.61 PK	74.00	-18.39	1.31 H	99	24.23	31.38
4	2486.00	47.06 AV	54.00	-6.94	1.31 H	99	15.68	31.38
5	4924.00	50.55 PK	74.00	-23.45	1.06 H	94	13.89	36.66
5	4924.00	40.82 AV	54.00	-13.18	1.06 H	94	4.16	36.66

### ANTENNA POLARITY & TEST DISTANCE: VERTICAL AT 3 M

No.	Freq. (MHz)	Emission Level (dBuV/m)	Limit (dBuV/m)	Margin (dB)	Antenna Height (m)	Table Angle (Degree)	Raw Value (dBuV)	Correction Factor (dB/m)
1	1066.00	47.52 PK	74.00	-26.48	1.00 V	275	20.76	26.76
1	1066.00	43.80 AV	54.00	-10.20	1.00 V	275	17.04	26.76
2	2016.00	50.81 PK	74.00	-23.19	1.31 V	360	21.40	29.41
2	2016.00	48.89 AV	54.00	-5.11	1.31 V	360	19.48	29.41
3	2360.00	61.71 PK	74.00	-12.29	1.08 V	48	30.86	30.85
3	2360.00	50.46 AV	54.00	-3.54	1.08 V	48	19.61	30.85
4	*2462.00	114.40 PK			1.04 V	57	83.12	31.28
4	*2462.00	108.01 AV			1.04 V	57	76.73	31.28
5	2486.00	63.36 PK	74.00	-10.64	1.04 V	57	31.98	31.38
5	2486.00	52.25 AV	54.00	-1.75	1.04 V	57	20.87	31.38
6	2688.00	48.35 PK	74.00	-25.65	1.20 V	34	16.57	31.78
6	2688.00	45.05 AV	54.00	-8.95	1.20 V	34	13.27	31.78
7	4924.00	56.94 PK	74.00	-17.06	1.25 V	195	20.28	36.66
7	4924.00	47.12 AV	54.00	-6.88	1.25 V	195	10.46	36.66
8	7386.00	52.95 PK	74.00	-21.05	1.28 V	312	10.35	42.59
8	7386.00	41.83 AV	54.00	-12.17	1.28 V	312	-0.77	42.59

- REMARKS:**
1. Emission level(dBuV/m)=Raw Value(dBuV) + Correction Factor(dB/m)
  2. Correction Factor(dB/m) = Antenna Factor (dB/m) + Cable Factor (dB)
  3. The other emission levels were very low against the limit.
  4. Margin value = Emission level – Limit value.
  5. The limit value is defined as per 15.247
  6. " \* " : Fundamental frequency



### 802.11g OFDM modulation

<b>EUT</b>	VA4200 Wi-Fi AP/Bridge	<b>MEASUREMENT DETAIL</b>	
<b>MODEL</b>	VA4200	<b>FREQUENCY RANGE</b>	1 ~ 25GHz
<b>CHANNEL</b>	Channel 1	<b>DETECTOR FUNCTION</b>	Peak(PK) Average (AV)
<b>MODULATION TYPE</b>	BPSK	<b>ENVIRONMENTAL CONDITIONS</b>	25deg. C, 68%RH, 991hPa
<b>TRANSFER RATE</b>	6Mbps	<b>INPUT POWER (SYSTEM)</b>	120Vac, 60 Hz
<b>TESTED BY</b>	Match Tsui		

#### ANTENNA POLARITY & TEST DISTANCE: HORIZONTAL AT 3 M

No.	Freq. (MHz)	Emission Level (dBuV/m)	Limit (dBuV/m)	Margin (dB)	Antenna Height (m)	Table Angle (Degree)	Raw Value (dBuV)	Correction Factor (dB/m)
1	2016.00	45.41 PK	74.00	-28.59	1.30 H	147	16.00	29.41
1	2016.00	41.47 AV	54.00	-12.53	1.30 H	147	12.06	29.41
2	2390.00	58.18 PK	74.00	-15.82	1.26 H	49	27.21	30.97
2	2390.00	47.02 AV	54.00	-6.98	1.26 H	49	16.05	30.97
3	*2412.00	99.53 PK			1.26 H	49	68.47	31.06
3	*2412.00	90.45 AV			1.26 H	49	59.39	31.06
4	4824.00	46.20 PK	74.00	-27.80	1.02 H	360	9.77	36.43
4	4824.00	33.61 AV	54.00	-20.39	1.02 H	360	-2.82	36.43

#### ANTENNA POLARITY & TEST DISTANCE: VERTICAL AT 3 M

No.	Freq. (MHz)	Emission Level (dBuV/m)	Limit (dBuV/m)	Margin (dB)	Antenna Height (m)	Table Angle (Degree)	Raw Value (dBuV)	Correction Factor (dB/m)
1	1066.00	47.24 PK	74.00	-26.76	1.02 V	283	20.48	26.76
1	1066.00	43.40 AV	54.00	-10.60	1.02 V	283	16.64	26.76
2	2016.00	46.89 PK	74.00	-27.11	1.02 V	329	17.48	29.41
2	2016.00	44.40 AV	54.00	-9.60	1.02 V	329	14.99	29.41
3	2360.00	58.03 PK	74.00	-15.97	1.13 V	322	27.18	30.85
3	2360.00	48.85 AV	54.00	-5.15	1.13 V	322	18.00	30.85
4	2390.00	65.28 PK	74.00	-8.72	1.13 V	322	34.31	30.97
4	2390.00	51.06 AV	54.00	-2.94	1.13 V	322	20.09	30.97
5	*2412.00	109.72 PK			1.13 V	322	78.66	31.06
5	*2412.00	99.58 AV			1.13 V	322	68.52	31.06
6	2688.00	49.51 PK	74.00	-24.49	1.00 V	321	17.73	31.78
6	2688.00	46.69 AV	54.00	-7.31	1.00 V	321	14.91	31.78
7	4824.00	51.00 PK	74.00	-23.00	1.00 V	215	14.57	36.43
7	4824.00	37.92 AV	54.00	-16.08	1.00 V	215	1.49	36.43

- REMARKS:**
1. Emission level(dBuV/m)=Raw Value(dBuV) + Correction Factor(dB/m)
  2. Correction Factor(dB/m) = Antenna Factor (dB/m) + Cable Factor (dB)
  3. The other emission levels were very low against the limit.
  4. Margin value = Emission level – Limit value.
  5. The limit value is defined as per 15.247
  6. “ \* “ : Fundamental frequency



<b>EUT</b>	VA4200 Wi-Fi AP/Bridge	<b>MEASUREMENT DETAIL</b>	
<b>MODEL</b>	VA4200	<b>FREQUENCY RANGE</b>	1 ~ 25GHz
<b>CHANNEL</b>	Channel 6	<b>DETECTOR FUNCTION</b>	Peak(PK) Average (AV)
<b>MODULATION TYPE</b>	BPSK	<b>ENVIRONMENTAL CONDITIONS</b>	25deg. C, 68%RH, 991hPa
<b>TRANSFER RATE</b>	6Mbps	<b>INPUT POWER (SYSTEM)</b>	120Vac, 60 Hz
<b>TESTED BY</b>	Match Tsui		

#### ANTENNA POLARITY & TEST DISTANCE: HORIZONTAL AT 3 M

No.	Freq. (MHz)	Emission Level (dBuV/m)	Limit (dBuV/m)	Margin (dB)	Antenna Height (m)	Table Angle (Degree)	Raw Value (dBuV)	Correction Factor (dB/m)
1	2016.00	47.71 PK	74.00	-26.29	1.00 H	7	18.30	29.41
1	2016.00	41.25 AV	54.00	-12.75	1.00 H	7	11.84	29.41
2	*2437.00	101.64 PK			1.30 H	100	70.47	31.17
2	*2437.00	91.79 AV			1.30 H	100	60.62	31.17
3	4874.00	47.32 PK	74.00	-26.68	1.11 H	211	10.78	36.54
3	4874.00	35.27 AV	54.00	-18.73	1.11 H	211	-1.27	36.54

#### ANTENNA POLARITY & TEST DISTANCE: VERTICAL AT 3 M

No.	Freq. (MHz)	Emission Level (dBuV/m)	Limit (dBuV/m)	Margin (dB)	Antenna Height (m)	Table Angle (Degree)	Raw Value (dBuV)	Correction Factor (dB/m)
1	1066.00	45.17 PK	74.00	-28.83	1.39 V	360	18.41	26.76
1	1066.00	40.73 AV	54.00	-13.27	1.39 V	360	13.97	26.76
2	2016.00	46.05 PK	74.00	-27.95	1.00 V	10	16.64	29.41
2	2016.00	43.61 AV	54.00	-10.39	1.00 V	10	14.20	29.41
3	2360.00	58.49 PK	74.00	-15.51	1.10 V	78	27.64	30.85
3	2360.00	48.73 AV	54.00	-5.27	1.10 V	78	17.88	30.85
4	*2437.00	110.40 PK			1.30 V	99	79.23	31.17
4	*2437.00	100.18 AV			1.30 V	99	69.01	31.17
5	4874.00	53.43 PK	74.00	-20.57	1.02 V	342	16.89	36.54
5	4874.00	39.92 AV	54.00	-14.08	1.02 V	342	3.38	36.54
6	7311.00	55.45 PK	74.00	-18.55	1.13 V	348	12.99	42.46
6	7311.00	41.47 AV	54.00	-12.53	1.13 V	348	-0.99	42.46

- REMARKS:**
1. Emission level(dBuV/m)=Raw Value(dBuV) + Correction Factor(dB/m)
  2. Correction Factor(dB/m) = Antenna Factor (dB/m) + Cable Factor (dB)
  3. The other emission levels were very low against the limit.
  4. Margin value = Emission level – Limit value.
  5. The limit value is defined as per 15.247
  6. “ \* “ : Fundamental frequency





<b>EUT</b>	VA4200 Wi-Fi AP/Bridge	<b>MEASUREMENT DETAIL</b>	
<b>MODEL</b>	VA4200	<b>FREQUENCY RANGE</b>	1 ~ 25GHz
<b>CHANNEL</b>	Channel 11	<b>DETECTOR FUNCTION</b>	Peak(PK) Average (AV)
<b>MODULATION TYPE</b>	BPSK	<b>ENVIRONMENTAL CONDITIONS</b>	25deg. C, 68%RH, 991hPa
<b>TRANSFER RATE</b>	6Mbps	<b>INPUT POWER (SYSTEM)</b>	120Vac, 60 Hz
<b>TESTED BY</b>	Match Tsui		

### ANTENNA POLARITY & TEST DISTANCE: HORIZONTAL AT 3 M

No.	Freq. (MHz)	Emission Level (dBuV/m)	Limit (dBuV/m)	Margin (dB)	Antenna Height (m)	Table Angle (Degree)	Raw Value (dBuV)	Correction Factor (dB/m)
1	1066.00	43.22 PK	74.00	-30.78	1.00 H	360	16.46	26.76
1	1066.00	39.07 AV	54.00	-14.93	1.00 H	360	12.31	26.76
2	*2462.00	100.67 PK			1.26 H	58	69.39	31.28
2	*2462.00	91.52 AV			1.26 H	58	60.24	31.28
3	2483.50	58.51 PK	74.00	-15.49	1.26 H	58	27.14	31.37
3	2483.50	47.41 AV	54.00	-6.59	1.26 H	58	16.04	31.37
4	4824.00	46.92 PK	74.00	-27.08	1.17 H	160	10.49	36.43
4	4824.00	33.54 AV	54.00	-20.46	1.17 H	160	-2.89	36.43

### ANTENNA POLARITY & TEST DISTANCE: VERTICAL AT 3 M

No.	Freq. (MHz)	Emission Level (dBuV/m)	Limit (dBuV/m)	Margin (dB)	Antenna Height (m)	Table Angle (Degree)	Raw Value (dBuV)	Correction Factor (dB/m)
1	1066.00	44.32 PK	74.00	-29.68	1.35 V	360	17.56	26.76
1	1066.00	39.29 AV	54.00	-14.71	1.35 V	360	12.53	26.76
2	2016.00	47.25 PK	74.00	-26.75	1.01 V	10	17.84	29.41
2	2016.00	44.09 AV	54.00	-9.91	1.01 V	10	14.68	29.41
3	2360.00	54.05 PK	74.00	-19.95	1.16 V	143	23.20	30.85
3	2360.00	45.37 AV	54.00	-8.63	1.16 V	143	14.52	30.85
4	*2462.00	110.64 PK			1.26 V	50	79.36	31.28
4	*2462.00	100.54 AV			1.26 V	50	69.26	31.28
5	2483.50	63.17 PK	74.00	-10.83	1.26 V	50	31.80	31.37
<b>5</b>	<b>2483.50</b>	<b>52.89 AV</b>	<b>54.00</b>	<b>-1.11</b>	<b>1.26 V</b>	<b>50</b>	<b>21.52</b>	<b>31.37</b>
6	2688.00	48.14 PK	74.00	-25.86	1.00 V	360	16.36	31.78
6	2688.00	45.01 AV	54.00	-8.99	1.00 V	360	13.23	31.78
7	4924.00	52.69 PK	74.00	-21.31	1.01 V	339	16.03	36.66
7	4924.00	39.38 AV	54.00	-14.62	1.01 V	339	2.72	36.66

- REMARKS:**
1. Emission level(dBuV/m)=Raw Value(dBuV) + Correction Factor(dB/m)
  2. Correction Factor(dB/m) = Antenna Factor (dB/m) + Cable Factor (dB)
  3. The other emission levels were very low against the limit.
  4. Margin value = Emission level – Limit value.
  5. The limit value is defined as per 15.247
  6. “ \* “ : Fundamental frequency



### 4.3 6dB BANDWIDTH MEASUREMENT

#### 4.3.1 LIMITS OF 6dB BANDWIDTH MEASUREMENT

The minimum of 6dB Bandwidth Measurement is 0.5 MHz.

#### 4.3.2 TEST INSTRUMENTS

Description & Manufacturer	Model No.	Serial No.	Calibrated Until
SPECTRUM ANALYZER	FSEK 30	100049	Aug. 12, 2005

**NOTE:** The calibration interval of the above test instruments is 12 months and the calibrations are traceable to NML/ROC and NIST/USA.

#### 4.3.3 TEST PROCEDURE

The transmitter output was connected to the spectrum analyzer through an attenuator. The bandwidth of the fundamental frequency was measured by spectrum analyzer with 100kHz RBW and 100kHz VBW. The 6dB bandwidth is defined as the total spectrum the power of which is higher than peak power minus 6dB.

#### 4.3.4 DEVIATION FROM TEST STANDARD

No deviation

#### 4.3.5 TEST SETUP



#### 4.3.6 EUT OPERATING CONDITIONS

The software provided by client to enable the EUT under transmission condition continuously at lowest, middle and highest channel frequencies individually.



## 4.3.7 TEST RESULTS

**802.11b DSSS modulation**

<b>EUT</b>	VA4200 Wi-Fi AP/Bridge	<b>MODEL</b>	VA4200
<b>MODULATION TYPE</b>	CCK	<b>TRANSFER RATE</b>	11Mbps
<b>INPUT POWER (SYSTEM)</b>	120Vac, 60 Hz	<b>ENVIRONMENTAL CONDITIONS</b>	25deg.C, 63%RH, 991hPa
<b>TESTED BY</b>	Jamison Chan		

<b>CHANNEL</b>	<b>CHANNEL FREQUENCY (MHz)</b>	<b>6dB BANDWIDTH (MHz)</b>	<b>MINIMUM LIMIT (MHz)</b>	<b>PASS/FAIL</b>
1	2412	12.24	0.5	PASS
6	2437	10.76	0.5	PASS
11	2462	11.92	0.5	PASS



CH 1

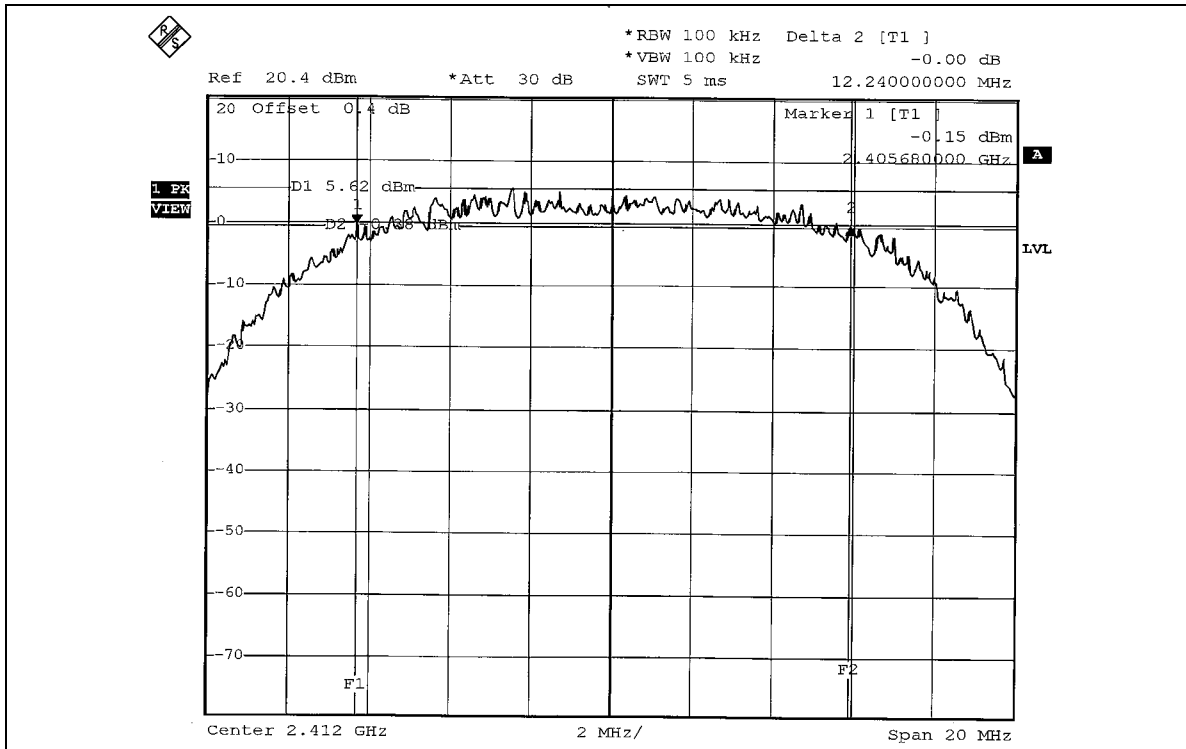

CH 6

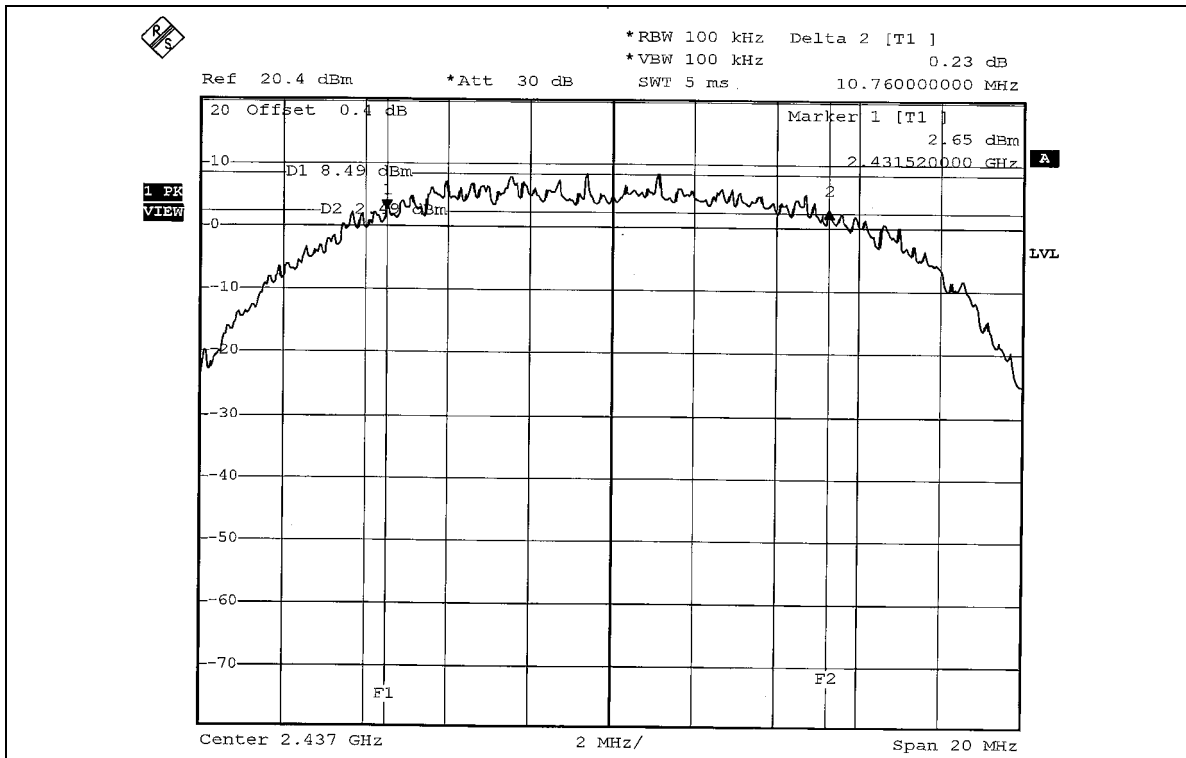



CH 11

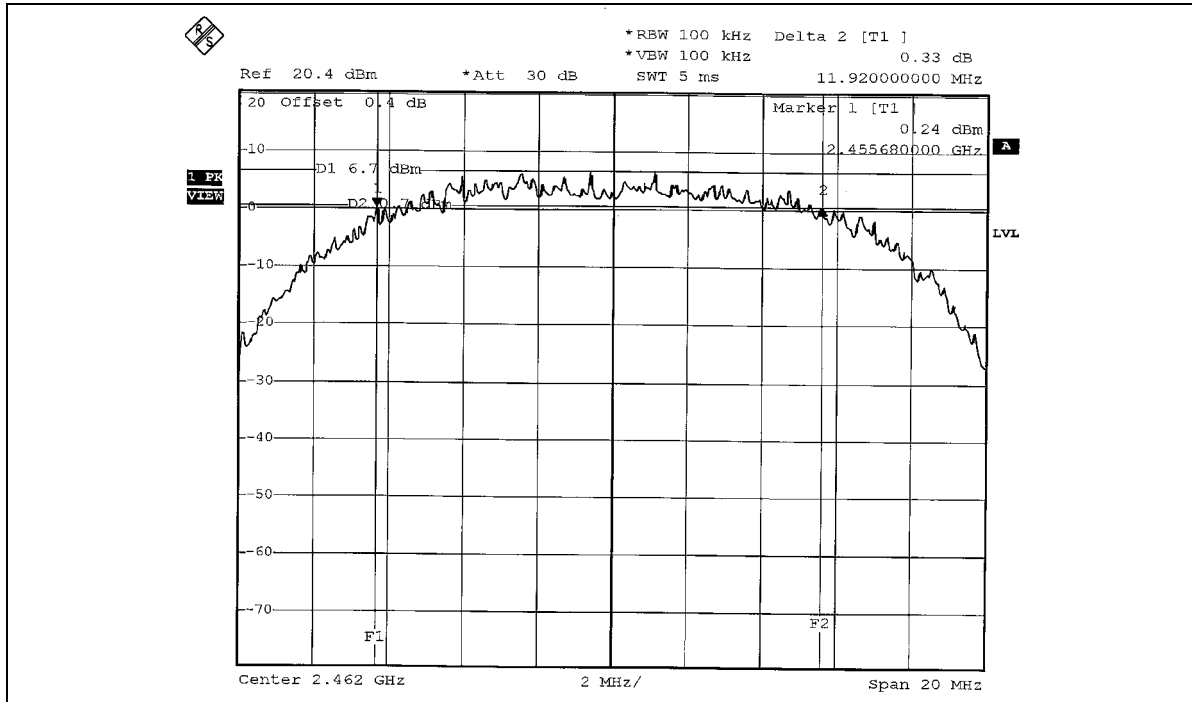



**802.11g OFDM modulation**

<b>EUT</b>	VA4200 Wi-Fi AP/Bridge	<b>MODEL</b>	VA4200
<b>MODULATION TYPE</b>	BPSK	<b>TRANSFER RATE</b>	6Mbps
<b>INPUT POWER (SYSTEM)</b>	120Vac, 60 Hz	<b>ENVIRONMENTAL CONDITIONS</b>	25deg.C, 63%RH, 991hPa
<b>TESTED BY</b>	Long Chen		

<b>CHANNEL</b>	<b>CHANNEL FREQUENCY (MHz)</b>	<b>6dB BANDWIDTH (MHz)</b>	<b>MINIMUM LIMIT (MHz)</b>	<b>PASS/FAIL</b>
1	2412	16.60	0.5	PASS
6	2437	16.60	0.5	PASS
11	2462	16.60	0.5	PASS



CH 1

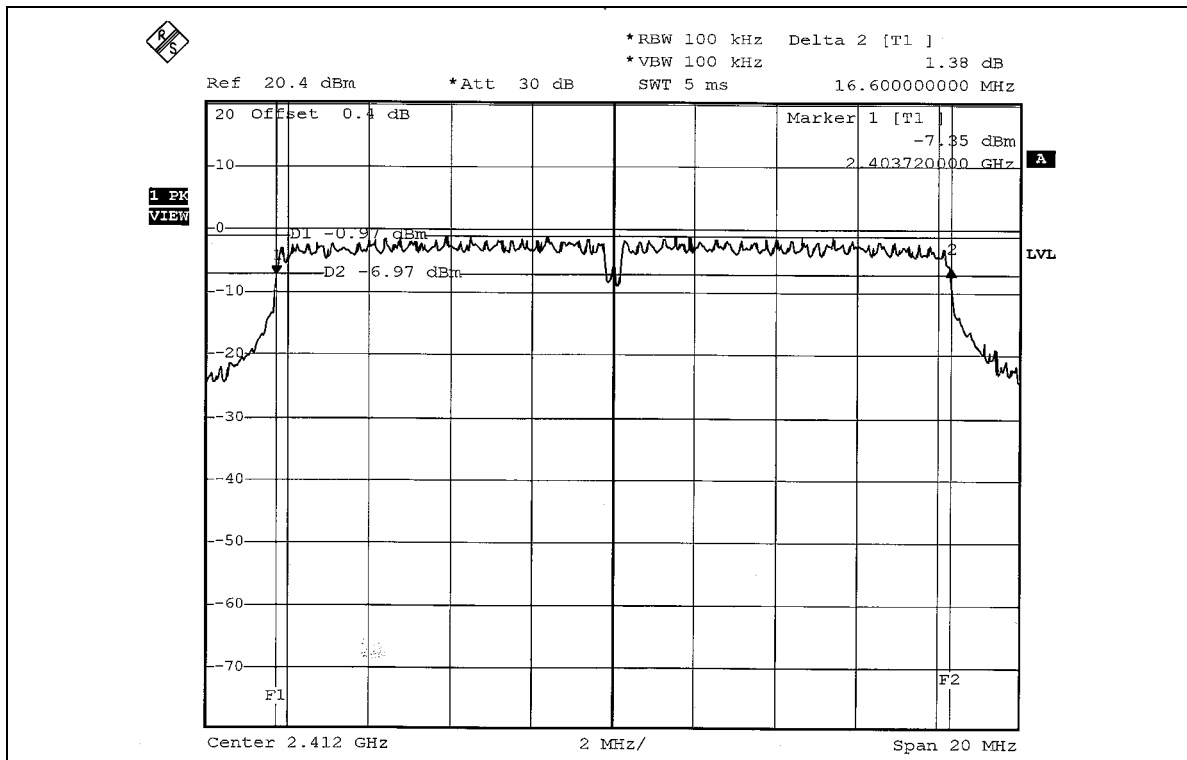

CH 6

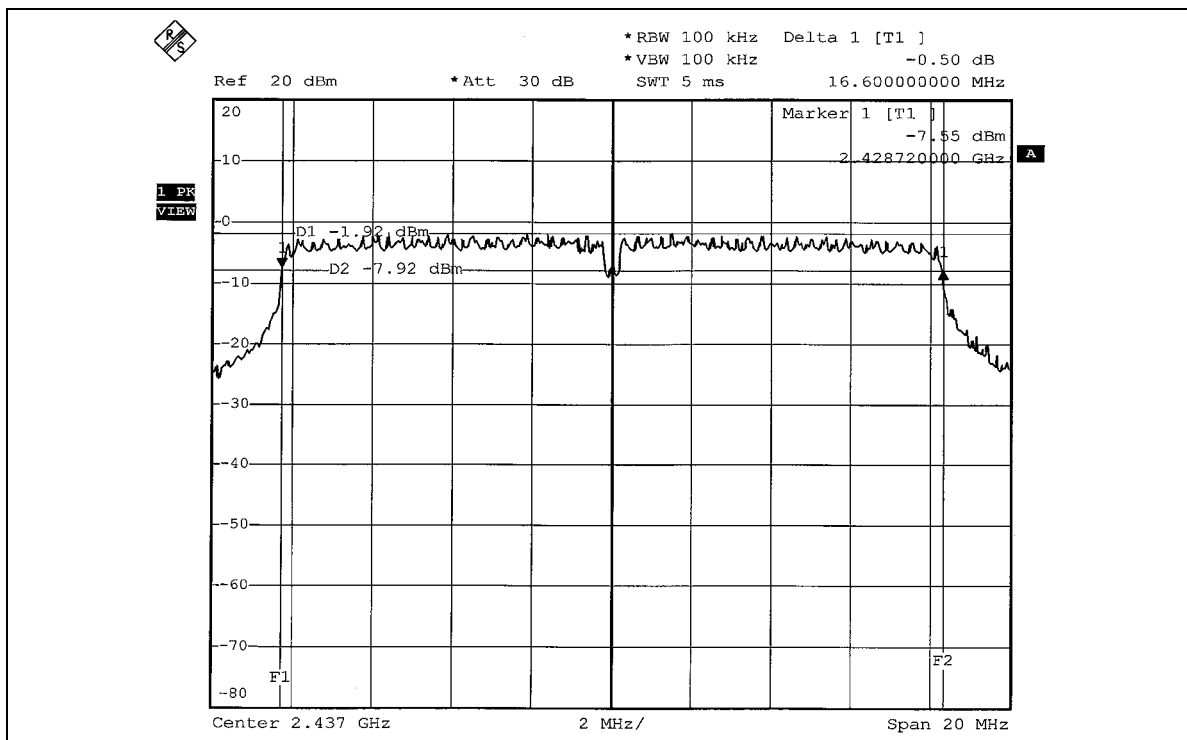





CH 11

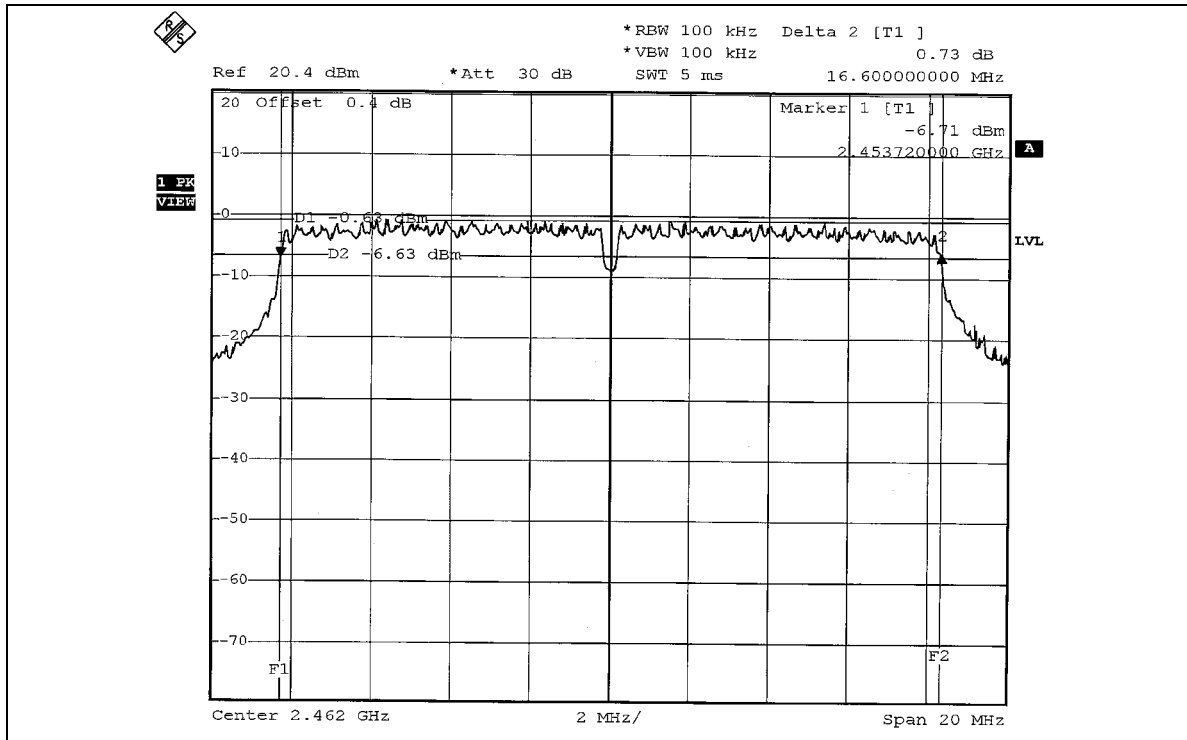



#### 4.4 MAXIMUM PEAK OUTPUT POWER

##### 4.4.1 LIMITS OF MAXIMUM PEAK OUTPUT POWER MEASUREMENT

The Maximum Peak Output Power Measurement is 30dBm.

##### 4.4.2 INSTRUMENTS

Description & Manufacturer	Model No.	Serial No.	Calibrated Until
R&S SPECTRUM ANALYZER	FSEK30	100049	Aug. 12, 2005
AGILENT SIGNAL GENERATOR	E8257C	MY43320668	Dec. 31, 2005
TEKTRONIX OSCILLOSCOPE	TDS 1012	C019167	Feb. 01, 2006
NARDA DETECTOR	4503A	FSCM99899	NA

**NOTE:**

The calibration interval of the above test instruments is 12 months and the calibrations are traceable to NML/ROC and NIST/USA.



#### 4.4.1 TEST PROCEDURES

1. A detector was used on the output port of the EUT. An oscilloscope was used to read the response of the detector.
2. Replaced the EUT by the signal generator. The center frequency of the S.G was adjusted to the center frequency of the measured channel.
3. Adjusted the power to have the same reading on oscilloscope. Record the power level.

#### 4.4.2 DEVIATION FROM TEST STANDARD

No deviation

#### 4.4.3 TEST SETUP



#### 4.4.4 EUT OPERATING CONDITIONS

Same as Item 4.3.6



## 4.4.3 TEST RESULTS

**802.11b DSSS modulation**

<b>EUT</b>	VA4200 Wi-Fi AP/Bridge	<b>MODEL</b>	VA4200
<b>MODULATION TYPE</b>	CCK	<b>TRANSFER RATE</b>	11Mbps
<b>INPUT POWER (SYSTEM)</b>	120Vac, 60 Hz	<b>ENVIRONMENTAL CONDITIONS</b>	25deg.C, 63%RH, 991hPa
<b>TESTED BY</b>	Long Chen		

CHANNEL	CHANNEL FREQUENCY (MHz)	PEAK POWER OUTPUT (mW)	PEAK POWER OUTPUT (dBm)	PEAK POWER LIMIT (dBm)	PASS/FAIL
1	2412	71.450	18.54	30	PASS
6	2437	101.158	20.05	30	PASS
11	2462	71.285	18.53	30	PASS

**802.11g OFDM modulation**

<b>EUT</b>	VA4200 Wi-Fi AP/Bridge	<b>MODEL</b>	VA4200
<b>MODULATION TYPE</b>	BPSK	<b>TRANSFER RATE</b>	6Mbps
<b>INPUT POWER (SYSTEM)</b>	120Vac, 60 Hz	<b>ENVIRONMENTAL CONDITIONS</b>	25deg.C, 63%RH, 991hPa
<b>TESTED BY</b>	Long Chen		

CHANNEL	CHANNEL FREQUENCY (MHz)	PEAK POWER OUTPUT (mW)	PEAK POWER OUTPUT (dBm)	PEAK POWER LIMIT (dBm)	PASS/FAIL
1	2412	57.280	17.58	30	PASS
6	2437	57.148	17.57	30	PASS
11	2462	56.364	17.51	30	PASS



## 4.5 POWER SPECTRAL DENSITY MEASUREMENT

### 4.5.1 LIMITS OF POWER SPECTRAL DENSITY MEASUREMENT

The Maximum of Power Spectral Density Measurement is 8dBm.

### 4.5.2 TEST INSTRUMENTS

Description & Manufacturer	Model No.	Serial No.	Calibrated Until
R&S SPECTRUM ANALYZER	FSEK30	100049	Aug. 12, 2005

**NOTE:**

The calibration interval of the above test instruments is 12 months and the calibrations are traceable to NML/ROC and NIST/USA.

#### 4.5.3 TEST PROCEDURE

The transmitter output was connected to the spectrum analyzer through an attenuator, the bandwidth of the fundamental frequency was measured with the spectrum analyzer using 3kHz RBW and 30kHz VBW, set sweep time = span/3kHz. The power spectral density was measured and recorded. The sweep time is allowed to be longer than span/3kHz for a full response of the mixer in the spectrum analyzer.

#### 4.5.4 DEVIATION FROM TEST STANDARD

No deviation

#### 4.5.5 TEST SETUP

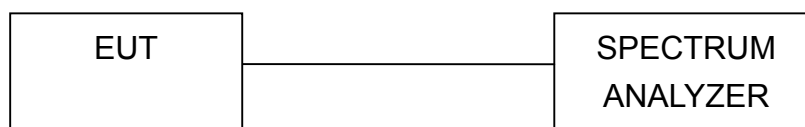

#### 4.5.6 EUT OPERATING CONDITION

Same as Item 4.3.6



## 4.5.7 TEST RESULTS

**802.11b DSSS modulation**

<b>EUT</b>	VA4200 Wi-Fi AP/Bridge	<b>MODEL</b>	VA4200
<b>MODULATION TYPE</b>	CCK	<b>TRANSFER RATE</b>	11Mbps
<b>INPUT POWER (SYSTEM)</b>	120Vac, 60 Hz	<b>ENVIRONMENTAL CONDITIONS</b>	25deg.C, 63%RH, 991hPa
<b>TESTED BY</b>	Long Chen		

<b>CHANNEL</b>	<b>CHANNEL FREQUENCY (MHz )</b>	<b>RF POWER LEVEL IN 3kHz BW (dBm)</b>	<b>MAXIMUM LIMIT (dBm)</b>	<b>PASS/FAIL</b>
1	2412	6.95	8	PASS
6	2437	7.50	8	PASS
11	2462	6.61	8	PASS



CH 1

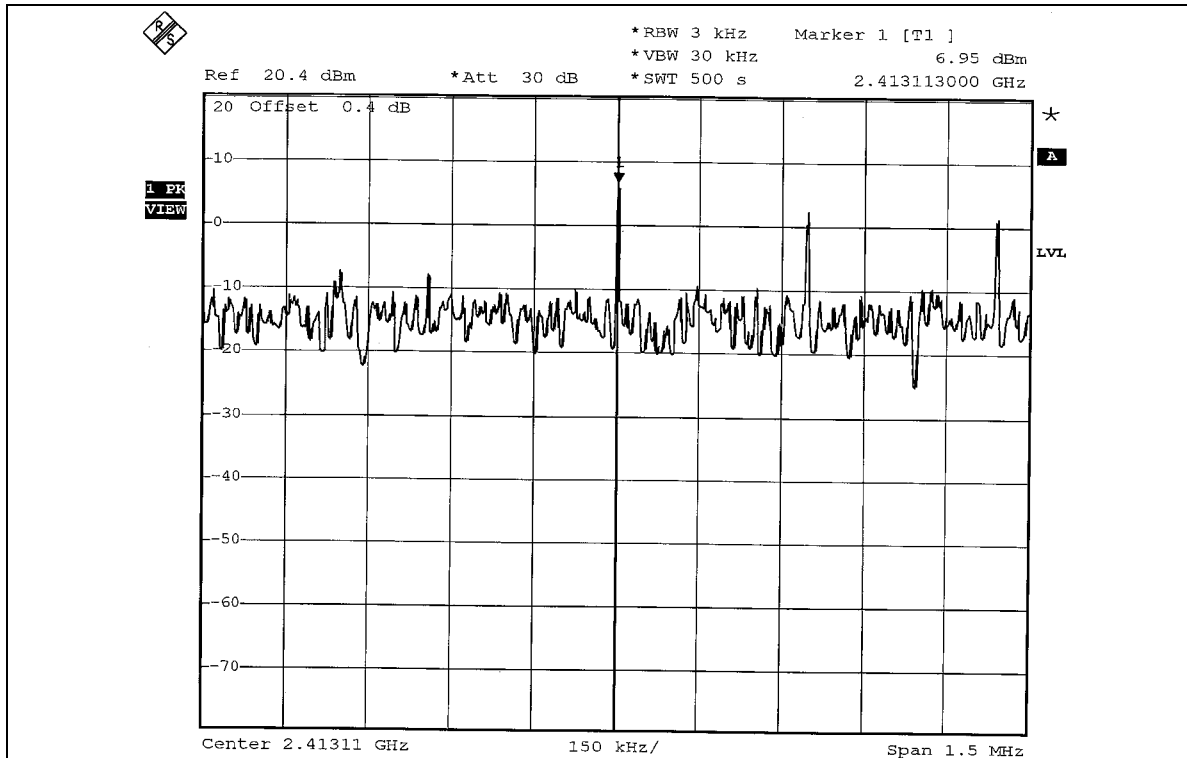

CH 6

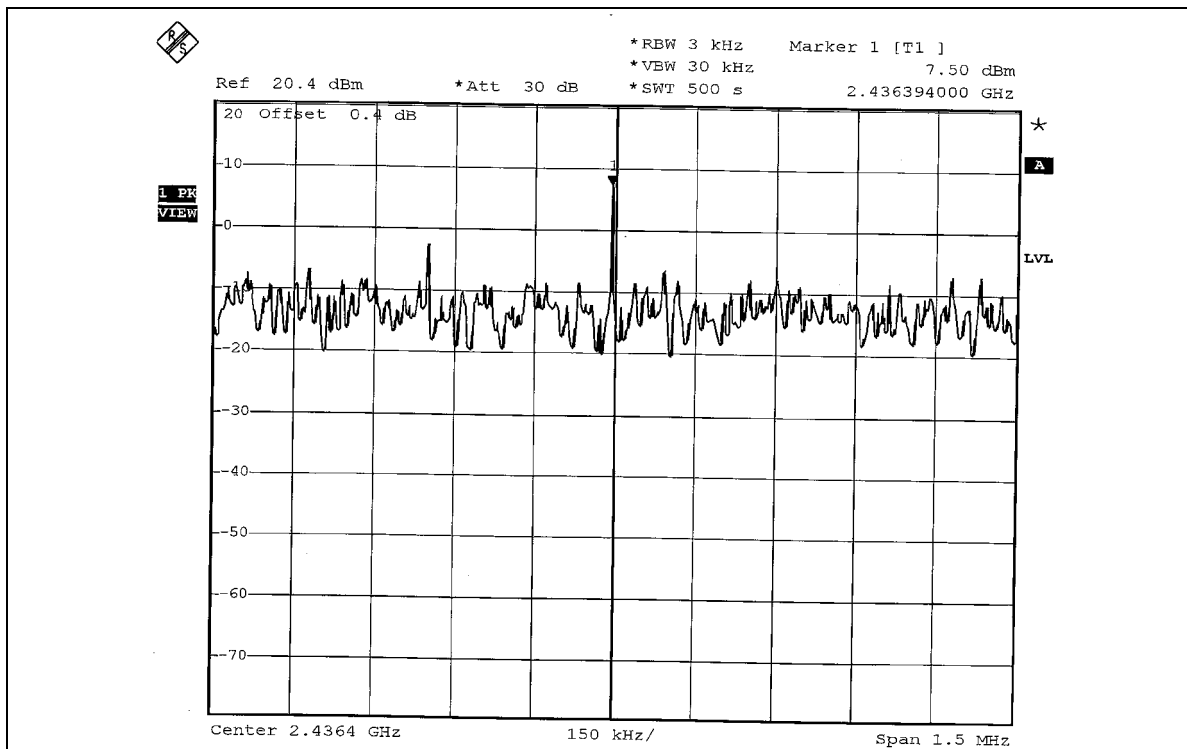





CH 11

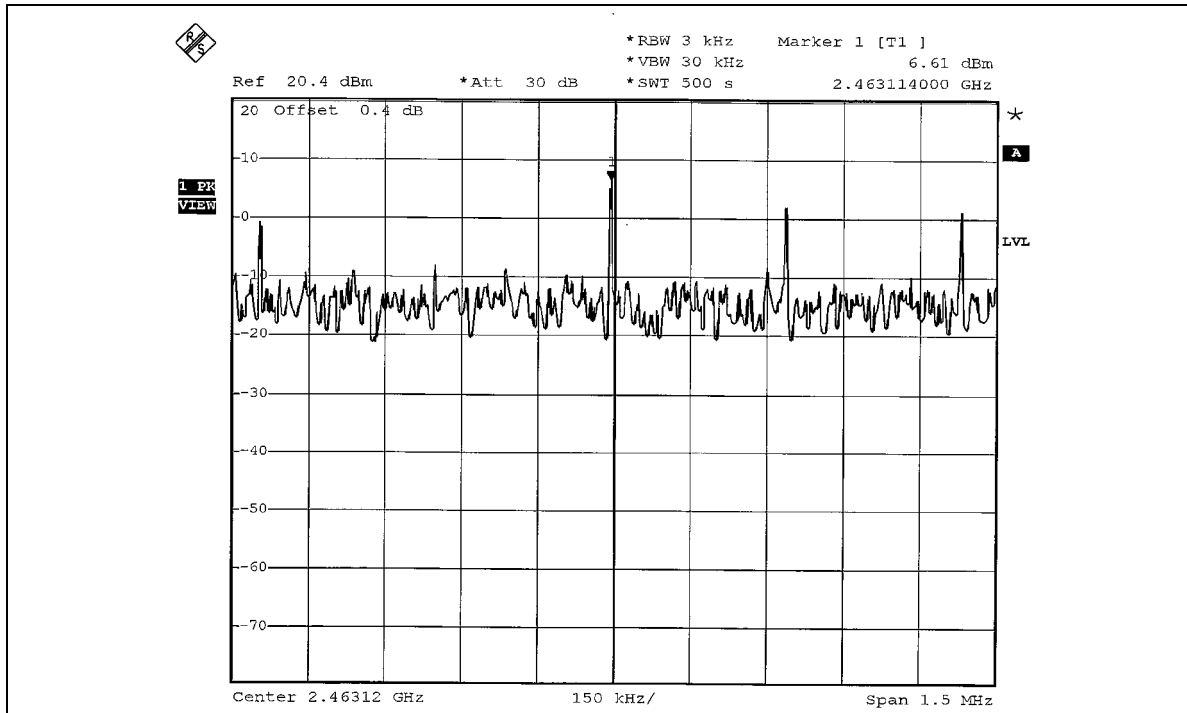

**802.11g OFDM modulation**

<b>EUT</b>	VA4200 Wi-Fi AP/Bridge	<b>MODEL</b>	VA4200
<b>MODULATION TYPE</b>	BPSK	<b>TRANSFER RATE</b>	6Mbps
<b>INPUT POWER (SYSTEM)</b>	120Vac, 60 Hz	<b>ENVIRONMENTAL CONDITIONS</b>	25deg.C, 63%RH, 991hPa
<b>TESTED BY</b>	Long Chen		

<b>CHANNEL</b>	<b>CHANNEL FREQUENCY (MHz )</b>	<b>RF POWER LEVEL IN 3kHz BW (dBm)</b>	<b>MAXIMUM LIMIT (dBm)</b>	<b>PASS/FAIL</b>
1	2412	-12.25	8	PASS
6	2437	-12.48	8	PASS
11	2462	-12.54	8	PASS



CH 1

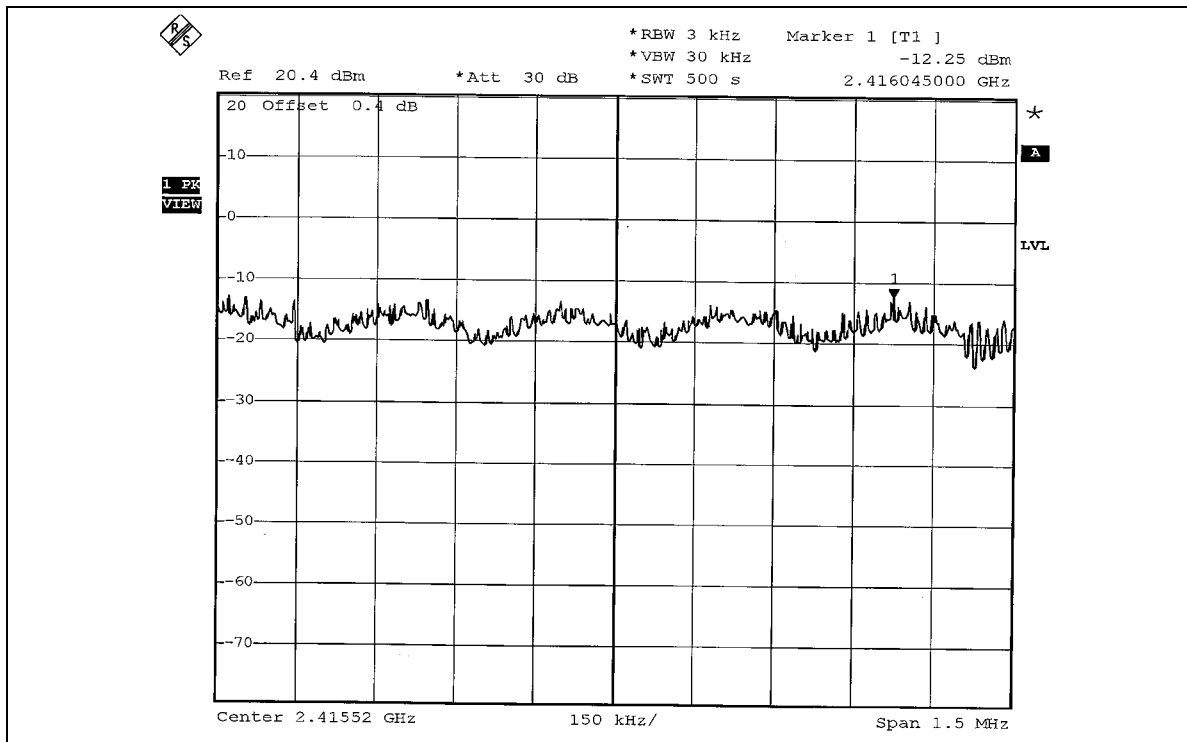

CH 6

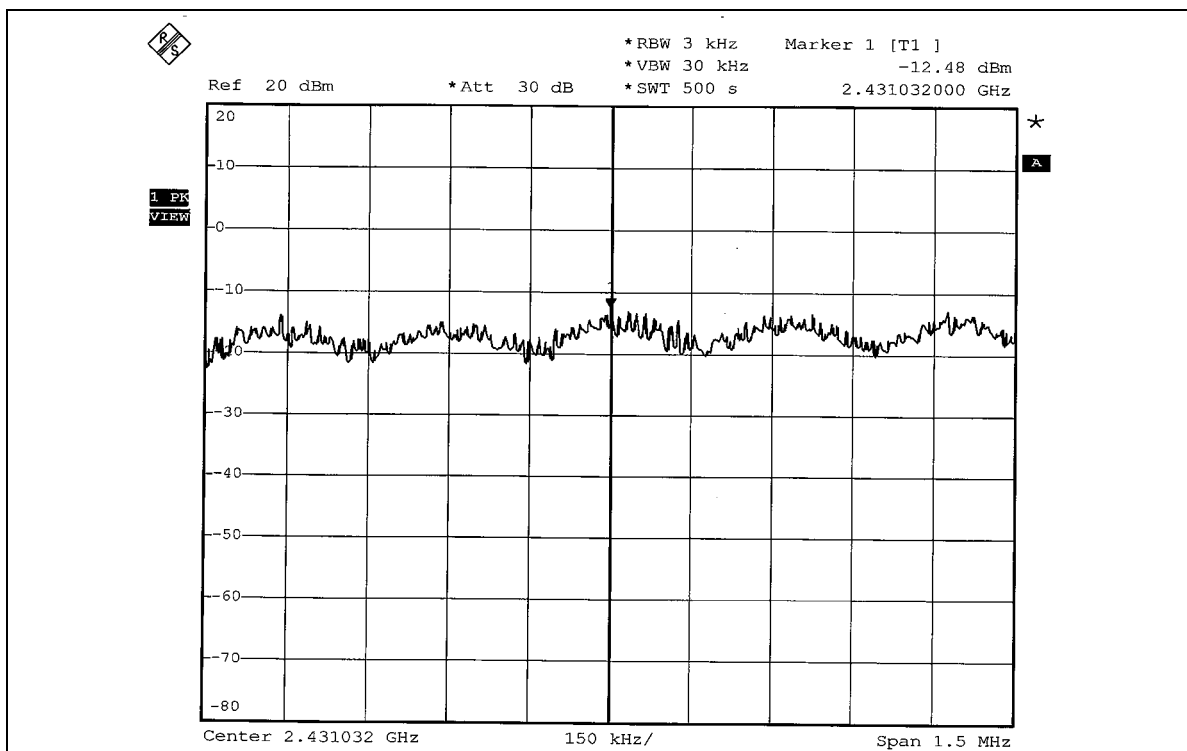



CH 11

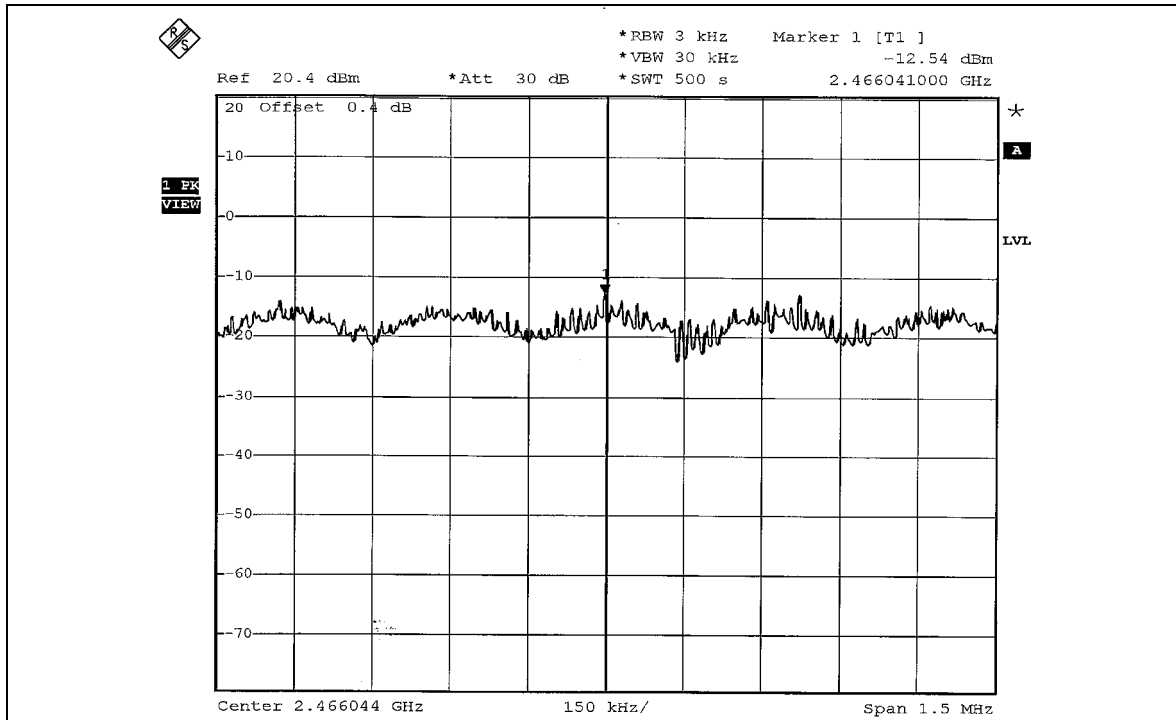



## 4.6 BAND EDGES MEASUREMENT

### 4.6.1 LIMITS OF BAND EDGES MEASUREMENT

Below -20dB of the highest emission level of operating band (in 100kHz Resolution Bandwidth).

### 4.6.2 TEST INSTRUMENTS

Description & Manufacturer	Model No.	Serial No.	Calibrated Until
R&S SPECTRUM ANALYZER	FSEK30	100049	Aug. 12, 2005

**NOTE:** The calibration interval of the above test instruments is 12 months and the calibrations are traceable to NML/ROC and NIST/USA.

### 4.6.3 TEST PROCEDURE

The transmitter output was connected to the spectrum analyzer via a low lose cable. Set both RBW and VBW of spectrum analyzer to 100kHz with suitable frequency span including 100 MHz bandwidth from band edge. The band edges was measured and recorded.

The spectrum plots (Peak RBW=VBW=100kHz ; Average RBW=1MHz, VBW=10Hz) are attached on the following pages.

### 4.6.4 DEVIATION FROM TEST STANDARD

No deviation

### 4.6.5 EUT OPERATING CONDITION

Same as Item 4.3.6



#### 4.6.6 TEST RESULTS

The spectrum plots are attached on the following 12 images. D2 line indicates the highest level, and D1 line indicates the 20dB offset below D2. It shows compliance with the requirement in part 15.247(d).

#### **802.11b DSSS modulation**

**NOTE 1:** The band edge emission plot on page 71 shows 52.76dBc between carrier maximum power and local maximum emission in restrict band (2.3850GHz). The emission of carrier strength list in the test result of channel 1 at the item 4.2.7 is 112.96dBuV/m (Peak), so the maximum field strength in restrict band is  $112.96 - 52.76 = 60.20$ dBuV/m which is under 74dBuV/m limit.

The band edge emission plot of on page 71 shows 56.81dBc between carrier maximum power and local maximum emission in restrict band (2.3870GHz). The emission of carrier strength list in the test result of channel 1 at the item 4.2.7 is 106.21dBuV/m (Average), so the maximum field strength in restrict band is  $106.21 - 56.81 = 49.40$ dBuV/m which is under 54dBuV/m limit.

**NOTE 2:** The band edge emission plot on page 72 shows 53.37dBc between carrier maximum power and local maximum emission in restrict band (2.4885GHz). The emission of carrier strength list in the test result of channel 11 at the item 4.2.7 is 114.40dBuV/m (Peak), so the maximum field strength in restrict band is  $114.40 - 53.37 = 61.03$ dBuV/m which is under 74dBuV/m limit.

The band edge emission plot on page 73 shows 58.42dBc between carrier maximum power and local maximum emission in restrict band (2.4835GHz). The emission of carrier strength list in the test result of channel 11 at the item 4.2.7 is 108.01dBuV/m (Average), so the maximum field strength in restrict band is  $108.01 - 58.42 = 49.59$ dBuV/m which is under 54dBuV/m limit.



### 802.11b DSSS modulation

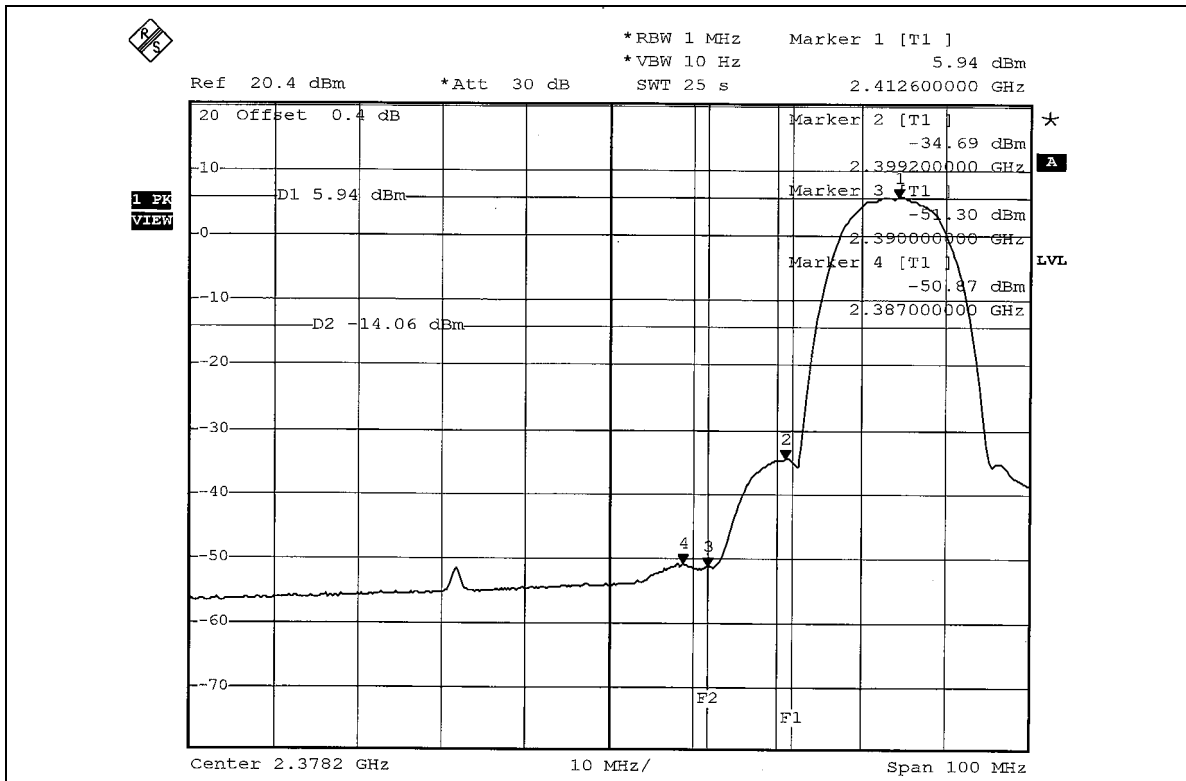
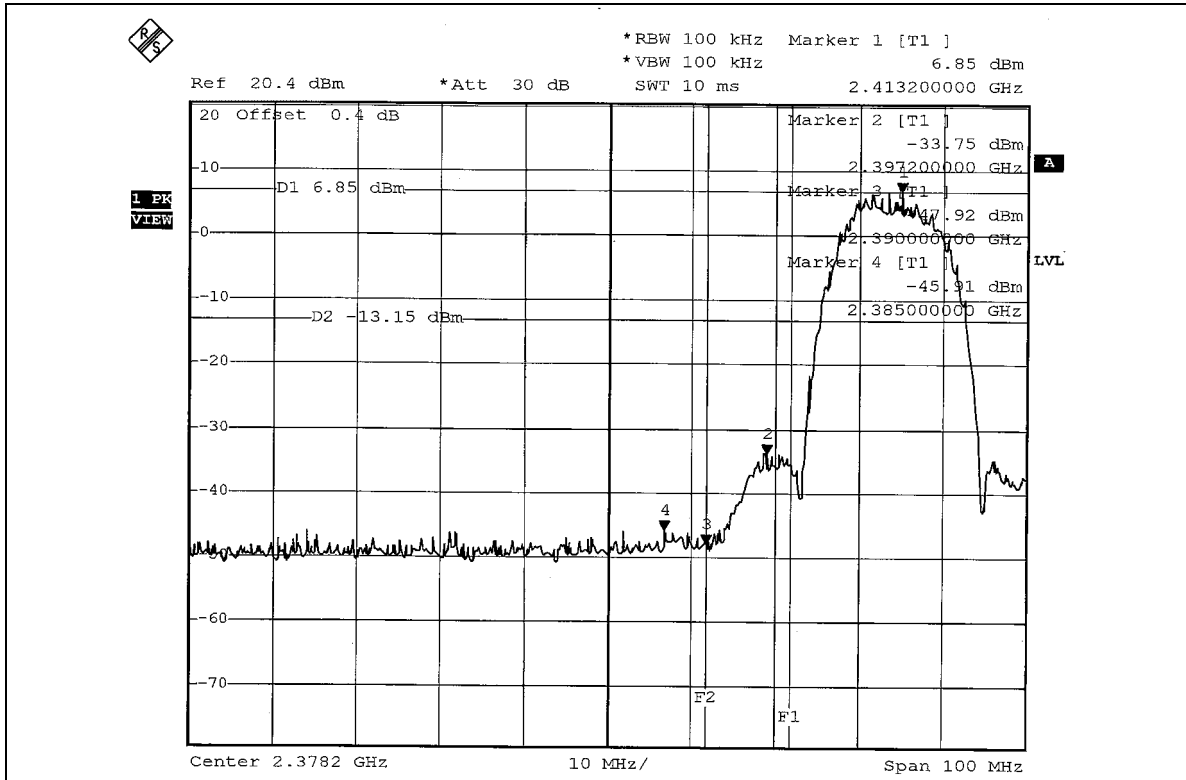

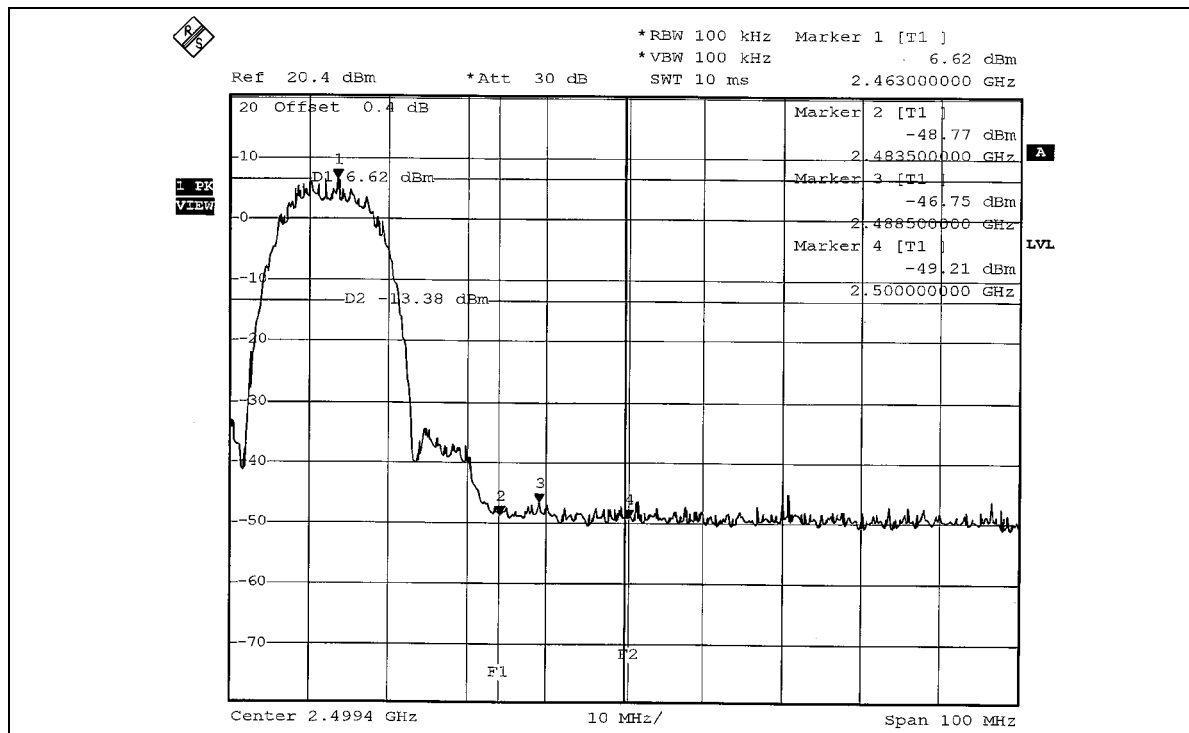
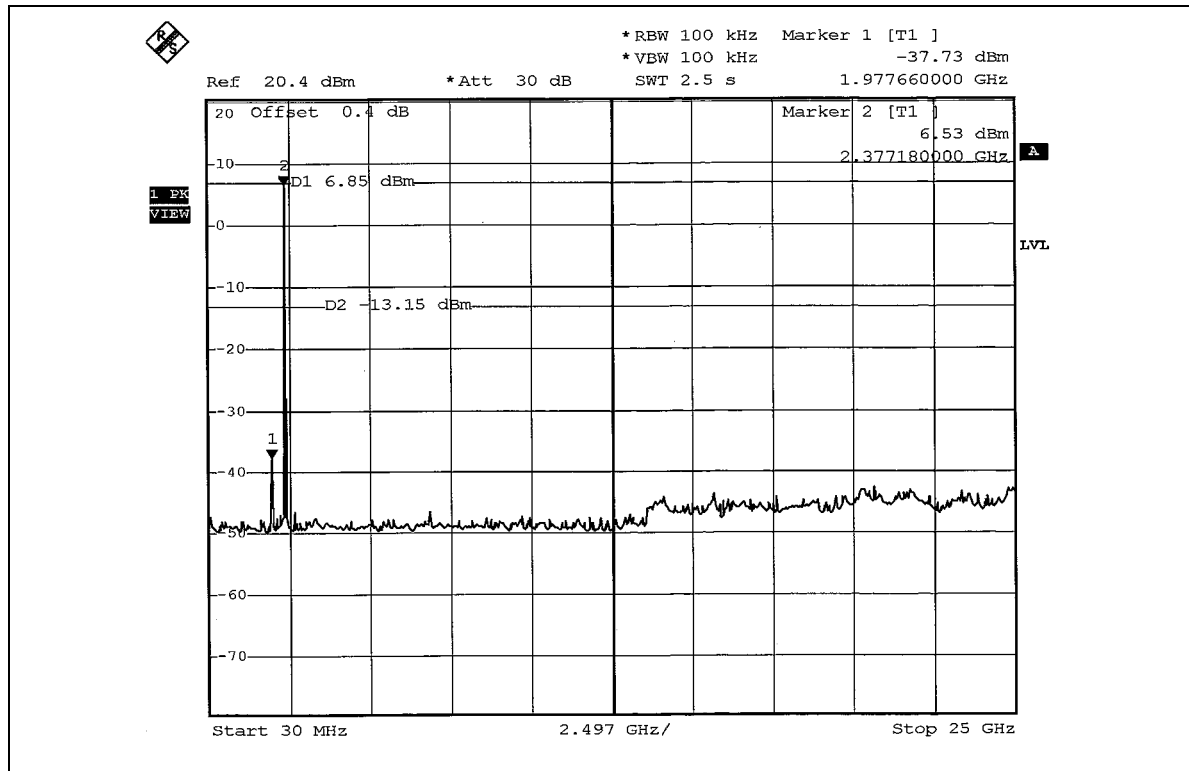



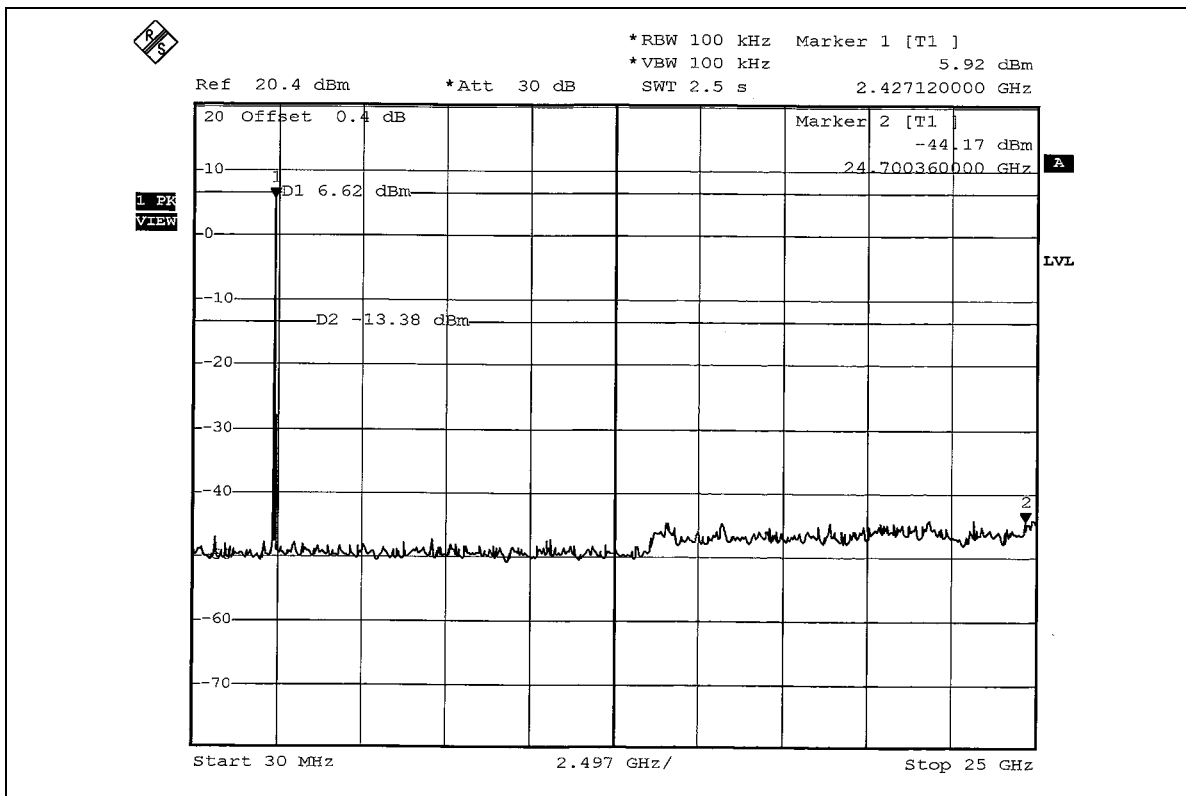
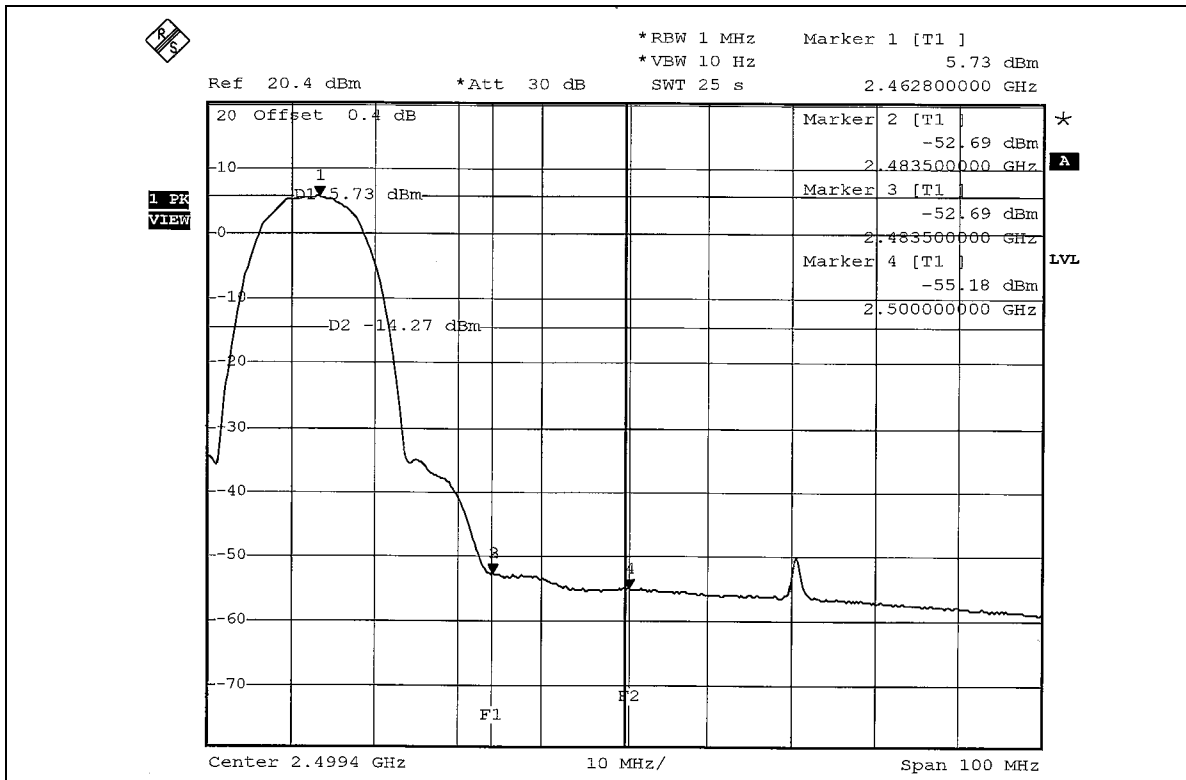



### 802.11g OFDM modulation

**NOTE 1:** The band edge emission plot on page 75 shows 44.36dBc between carrier maximum power and local maximum emission in restrict band (2.3900GHz). The emission of carrier strength list in the test result of channel 1 at the item 4.2.7 is 109.72dBuV/m (Peak), so the maximum field strength in restrict band is  $109.72 - 44.36 = 65.36$  dBuV/m which is under 74dBuV/m limit.

The band edge emission plot of on page 75 shows 48.64dBc between carrier maximum power and local maximum emission in restrict band (2.3900GHz). The emission of carrier strength list in the test result of channel 1 at the item 4.2.7 is 99.58dBuV/m (Average), so the maximum field strength in restrict band is  $99.58 - 48.64 = 50.94$  dBuV/m which is under 54dBuV/m limit.

**NOTE 2:** The band edge emission plot on page 76 shows 43.51dBc between carrier maximum power and local maximum emission in restrict band (2.4835GHz). The emission of carrier strength list in the test result of channel 11 at the item 4.2.7 is 110.64dBuV/m (Peak), so the maximum field strength in restrict band is  $110.64 - 43.51 = 67.13$  dBuV/m which is under 74dBuV/m limit.

The band edge emission plot on page 77 shows 49.31dBc between carrier maximum power and local maximum emission in restrict band (2.4835GHz). The emission of carrier strength list in the test result of channel 11 at the item 4.2.7 is 100.54dBuV/m (Average), so the maximum field strength in restrict band is  $100.54 - 49.31 = 51.23$  dBuV/m which is under 54dBuV/m limit.



### 802.11g OFDM modulation

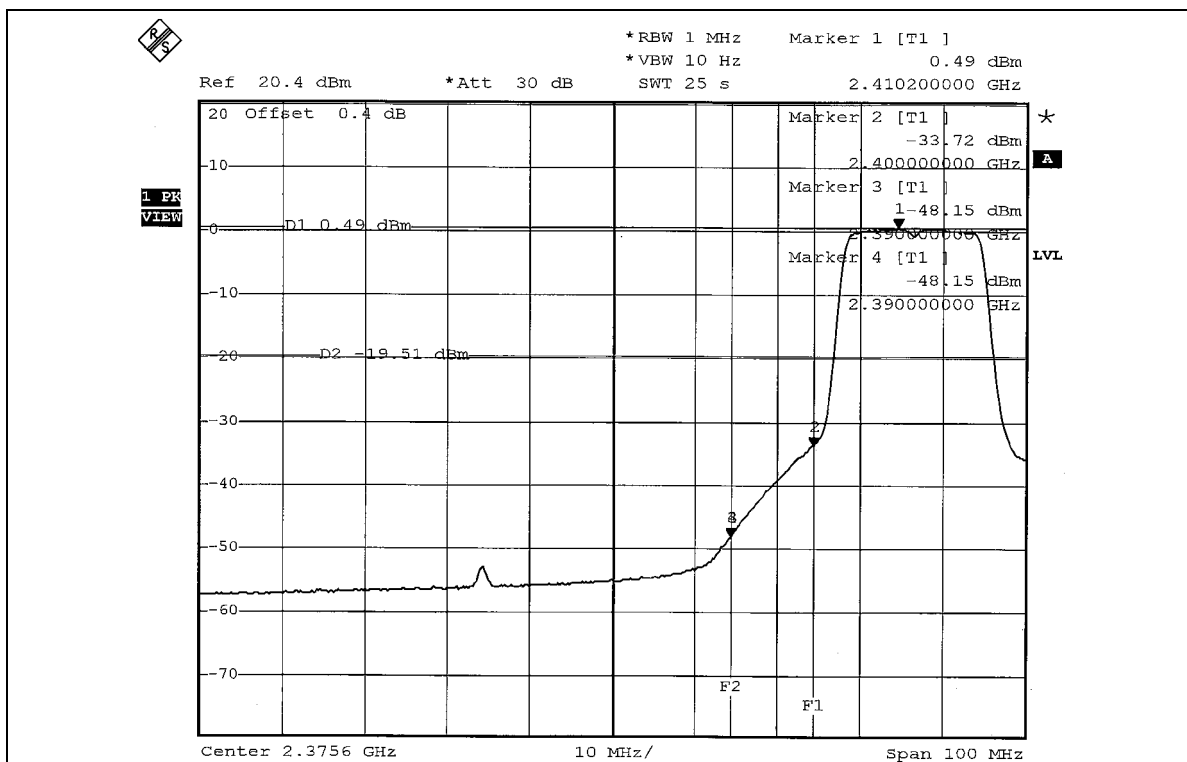
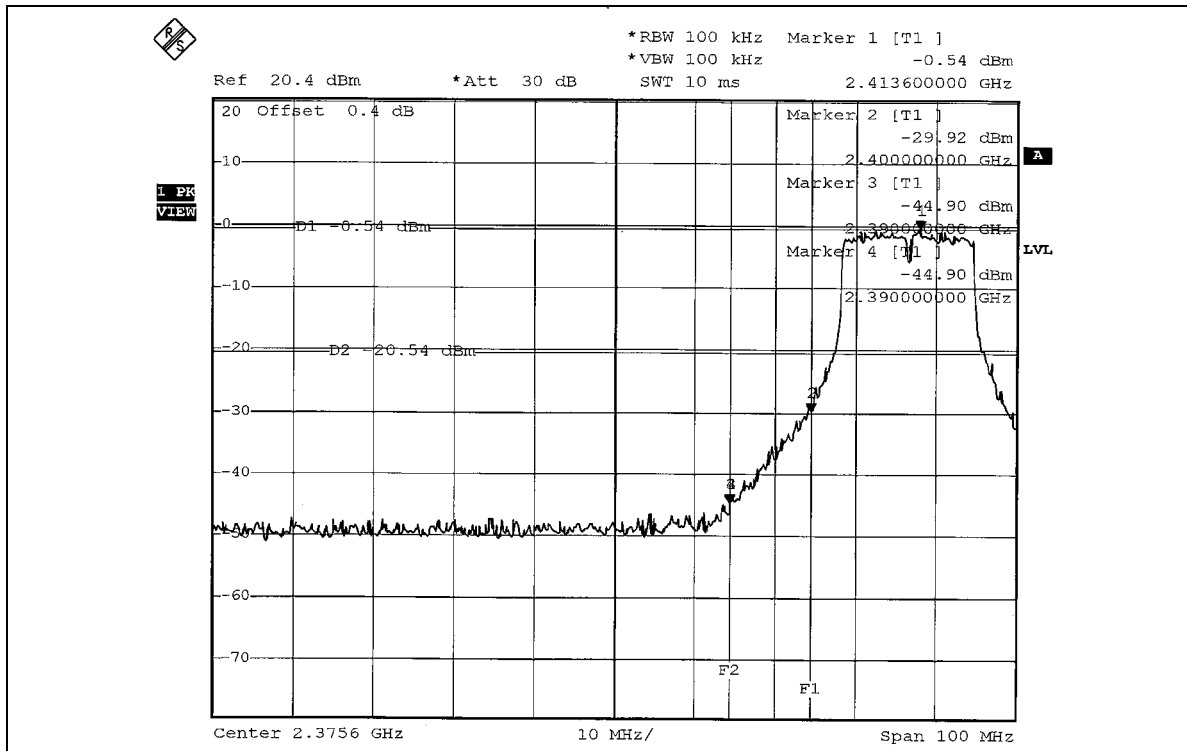

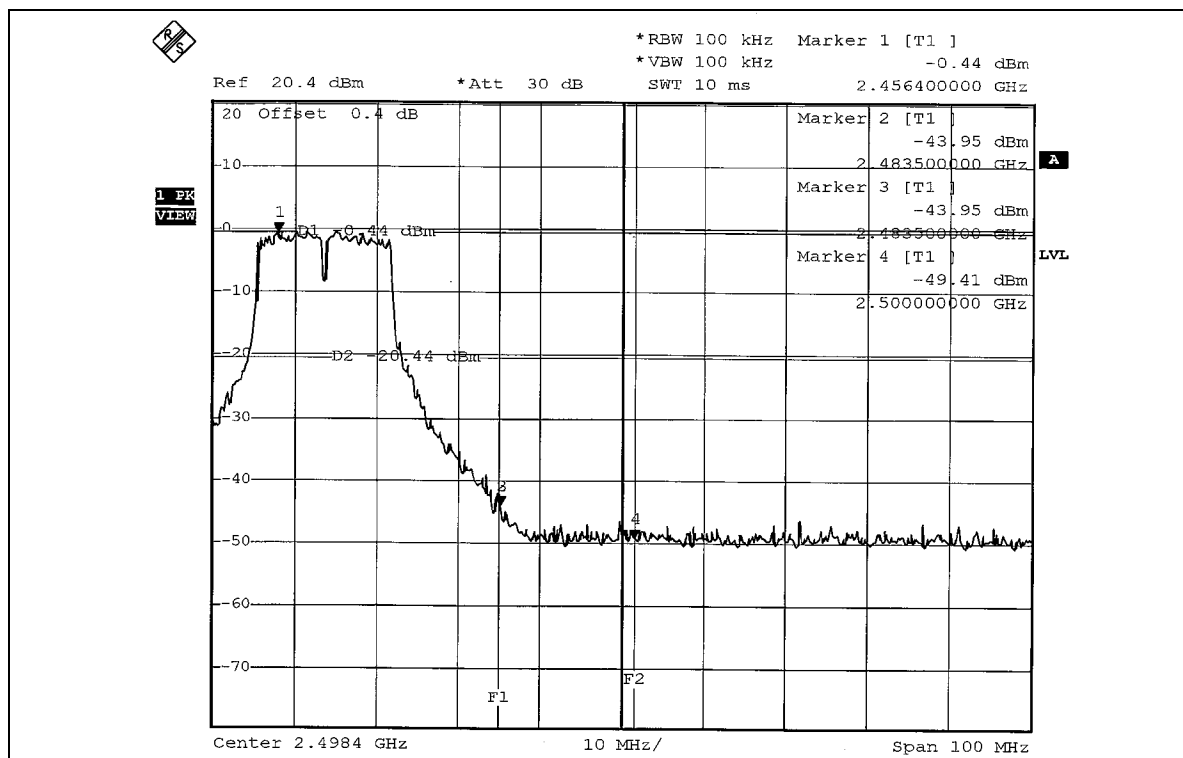
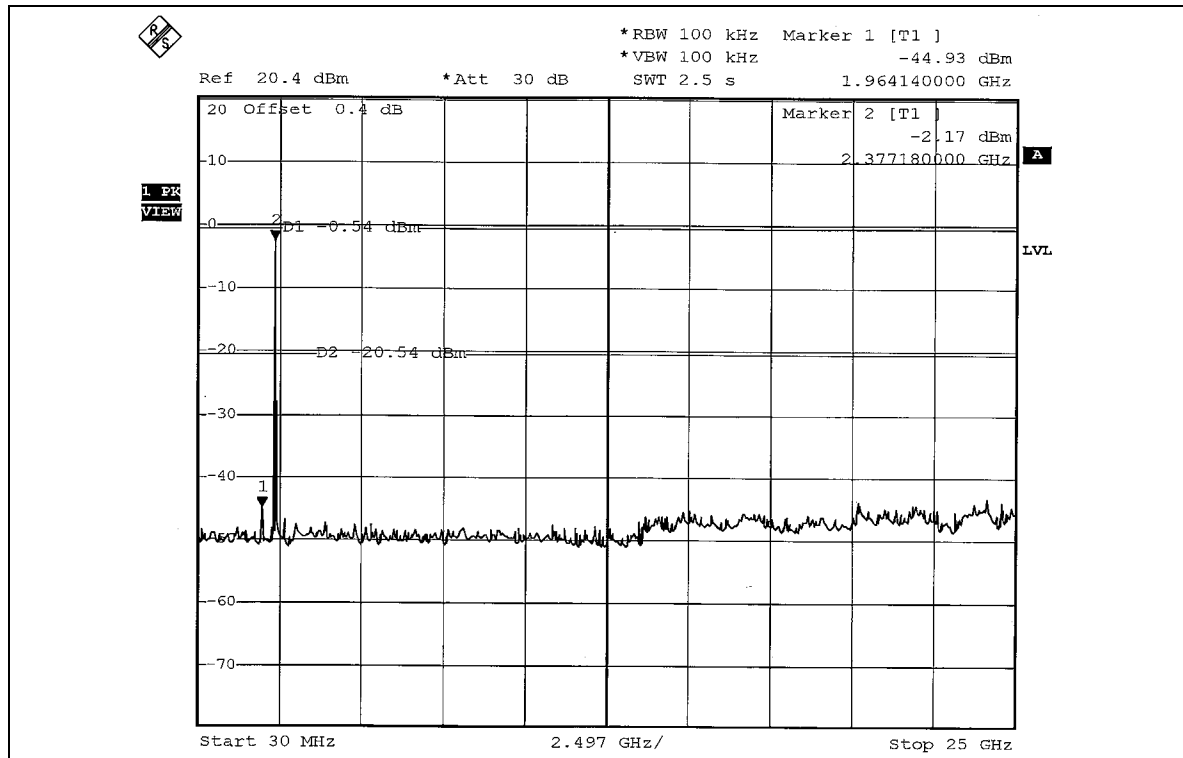

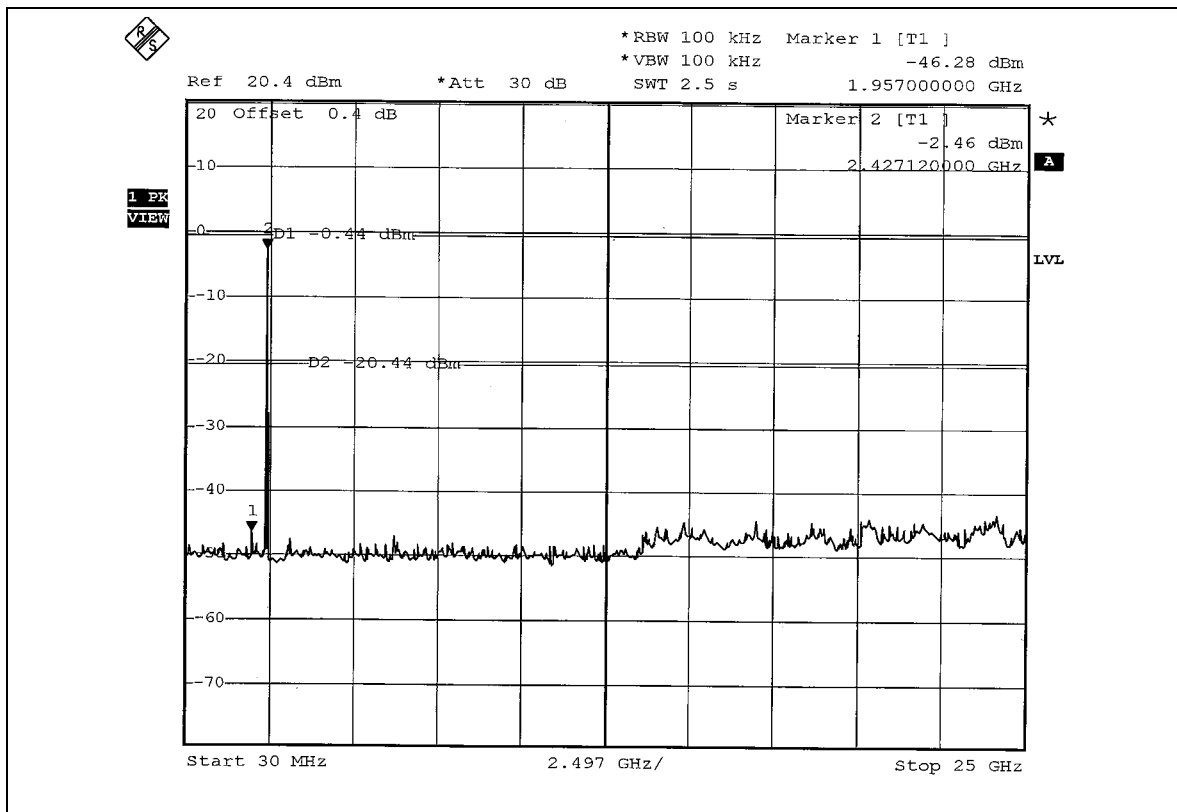
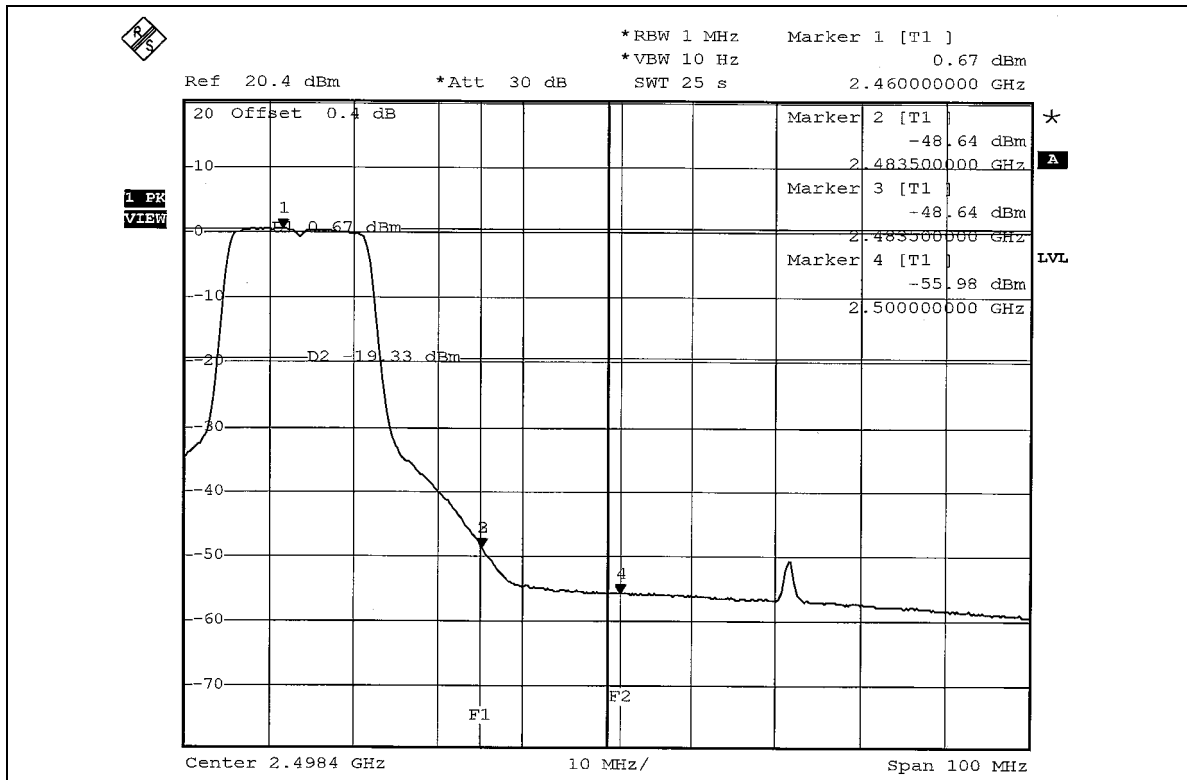



## **4.7 ANTENNA REQUIREMENT**

### **4.7.1 STANDARD APPLICABLE**

For intentional device, according to FCC 47 CFR Section 15.203, an intentional radiator shall be designed to ensure that no antenna other than that furnished by the responsible party shall be used with the device. And according to FCC 47 CFR Section 15.247 (b), if transmitting antennas of directional gain greater than 6dBi are used, the power shall be reduced by the amount in dB that the directional gain of the antenna exceeds 6dBi.

### **4.7.2 ANTENNA CONNECTED CONSTRUCTION**

The antenna used in this product is Dipole antenna with Reverse-TNC connector. The maximum Gain of the antenna is 2.0dBi.



## 5. TEST TYPES AND RESULTS (802.11a 5725~5850MHz Band)

### 5.1 CONDUCTED EMISSION MEASUREMENT

#### 5.1.1 LIMITS OF CONDUCTED EMISSION MEASUREMENT

FREQUENCY OF EMISSION (MHz)	CONDUCTED LIMIT (dB $\mu$ V)	
	Quasi-peak	Average
0.15-0.5	66 to 56	56 to 46
0.5-5	56	46
5-30	60	50

- NOTE:**
- The lower limit shall apply at the transition frequencies.
    - The limit decreases in line with the logarithm of the frequency in the range of 0.15 to 0.50 MHz.
    - All emanations from a class A/B digital device or system, including any network of conductors and apparatus connected thereto, shall not exceed the level of field strengths specified above.

#### 5.1.2 TEST INSTRUMENTS

DESCRIPTION & MANUFACTURER	MODEL NO.	SERIAL NO.	CALIBRATED UNTIL
Test Receiver ROHDE & SCHWARZ	ESCS30	100288	Nov. 06, 2005
RF signal cable Woken	5D-FB	Cable-HyC02-01	Jan. 09, 2006
LISN ROHDE & SCHWARZ	ESH2-Z5	100100	Jan. 20, 2006
LISN ROHDE & SCHWARZ	ESH3-Z5	100311	Jan. 20, 2006
Software ADT	ADT_Cond_V3	NA	NA

- NOTE:**
- The calibration interval of the above test instruments is 12 months and the calibrations are traceable to NML/ROC and NIST/USA.
  - The test was performed in HwaYa Shielded Room 3.
  - The VCCI Site Registration No. is C-2047.



### 5.1.3 TEST PROCEDURES

- a. The EUT was placed 0.4 meters from the conducting wall of the shielded room with EUT being connected to the power mains through a line impedance stabilization network (LISN). Other support units were connected to the power mains through another LISN. The two LISNs provide 50 ohm/ 50uH of coupling impedance for the measuring instrument.
- b. Both lines of the power mains connected to the EUT were checked for maximum conducted interference.
- c. The frequency range from 150kHz to 30MHz was searched. Emission levels under (Limit – 20dB) was not recorded.

### 5.1.4 DEVIATION FROM TEST STANDARD

No deviation



### 5.1.5 TEST SETUP

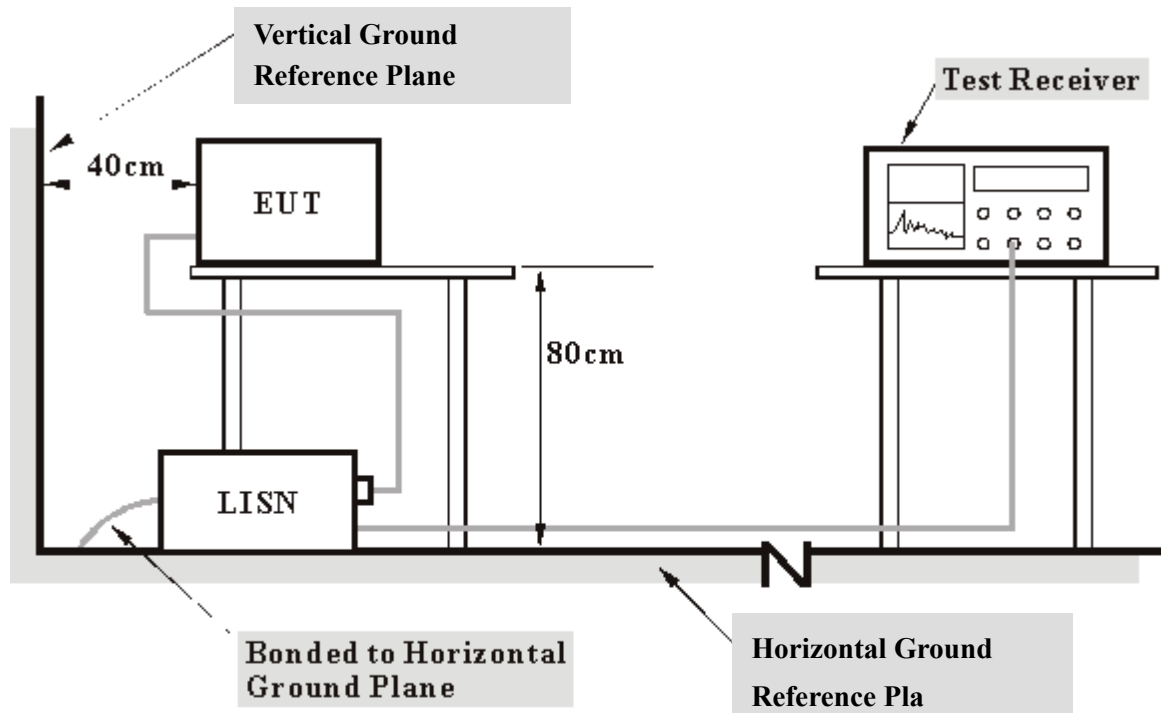

- Note:**
1. Support units were connected to second LISN.
  2. Both of LISNs (AMN) 80 cm from EUT and at the least 80 cm from other units and other metal planes support units.

For the actual test configuration, please refer to the related item – Photographs of the Test Configuration.

### 5.1.6 EUT OPERATING CONDITIONS

Same as 4.1.6



5.1.7 TEST RESULTS

Conducted Worst-Case Data (Power from AC Adapter: RHE-120150-7)

<b>EUT</b>	VA4200 Wi-Fi AP/Bridge	<b>MEASUREMENT DETAIL</b>	
<b>MODEL</b>	VA4200	<b>PHASE</b>	Line 1
<b>CHANNEL</b>	Channel 1	<b>6dB BANDWIDTH</b>	9 kHz
<b>MODULATION TYPE</b>	BPSK	<b>ENVIRONMENTAL CONDITIONS</b>	23deg. C, 65%RH, 991hPa
<b>TRANSFER RATE</b>	6Mbps	<b>INPUT POWER (SYSTEM)</b>	120Vac, 60 Hz
<b>TEST MODE</b>	1	<b>TESTED BY</b>	Gary Chang

No	Freq. [MHz]	Corr. Factor (dB)	Reading Value [dB (uV)]		Emission Level [dB (uV)]		Limit [dB (uV)]		Margin (dB)	
			Q.P.	AV.	Q.P.	AV.	Q.P.	AV.	Q.P.	AV.
			1	0.177	0.10	54.18	-	54.28	-	64.61
2	0.232	0.10	42.25	-	42.35	-	62.38	52.38	-20.03	-
3	0.533	0.12	41.37	-	41.49	-	56.00	46.00	-14.51	-
4	0.591	0.13	40.40	-	40.53	-	56.00	46.00	-15.47	-
5	13.418	0.37	37.75	-	38.12	-	60.00	50.00	-21.88	-
6	17.691	0.62	38.76	-	39.38	-	60.00	50.00	-20.62	-

- REMARKS:**
1. Q.P. and AV. are abbreviations of quasi-peak and average individually.
  2. "-": The Quasi-peak reading value also meets average limit and measurement with the average detector is unnecessary.
  3. The emission levels of other frequencies were very low against the limit.
  4. Margin value = Emission level - Limit value
  5. Correction factor = Insertion loss + Cable loss
  6. Emission Level = Correction Factor + Reading Value.

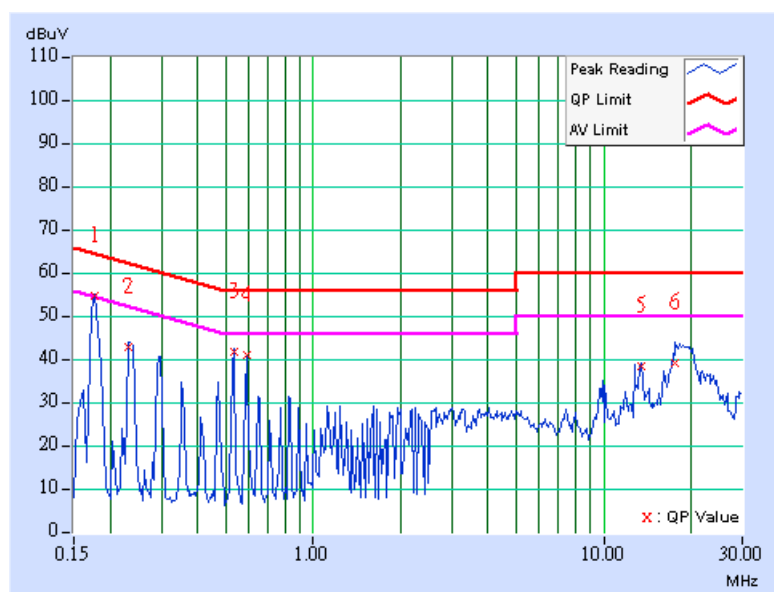



<b>EUT</b>	VA4200 Wi-Fi AP/Bridge	<b>MEASUREMENT DETAIL</b>	
<b>MODEL</b>	VA4200	<b>PHASE</b>	Line 2
<b>CHANNEL</b>	Channel 1	<b>6dB BANDWIDTH</b>	9 kHz
<b>MODULATION TYPE</b>	BPSK	<b>ENVIRONMENTAL CONDITIONS</b>	23deg. C, 65%RH, 991hPa
<b>TRANSFER RATE</b>	6Mbps	<b>INPUT POWER (SYSTEM)</b>	120Vac, 60 Hz
<b>TEST MODE</b>	1	<b>TESTED BY</b>	Gary Chang

No	Freq. [MHz]	Corr. Factor (dB)	Reading Value [dB (uV)]		Emission Level [dB (uV)]		Limit [dB (uV)]		Margin (dB)	
			Q.P.	AV.	Q.P.	AV.	Q.P.	AV.	Q.P.	AV.
1	0.177	0.10	54.26	-	54.36	-	64.61	54.61	-10.25	-
2	0.236	0.10	48.18	-	48.28	-	62.24	52.24	-13.96	-
3	0.533	0.12	42.37	-	42.49	-	56.00	46.00	-13.51	-
4	0.591	0.13	41.44	-	41.57	-	56.00	46.00	-14.43	-
5	13.418	0.47	38.05	-	38.52	-	60.00	50.00	-21.48	-
6	17.938	0.68	38.85	-	39.53	-	60.00	50.00	-20.47	-

- REMARKS:**
1. Q.P. and AV. are abbreviations of quasi-peak and average individually.
  2. "-": The Quasi-peak reading value also meets average limit and measurement with the average detector is unnecessary.
  3. The emission levels of other frequencies were very low against the limit.
  4. Margin value = Emission level - Limit value
  5. Correction factor = Insertion loss + Cable loss
  6. Emission Level = Correction Factor + Reading Value.

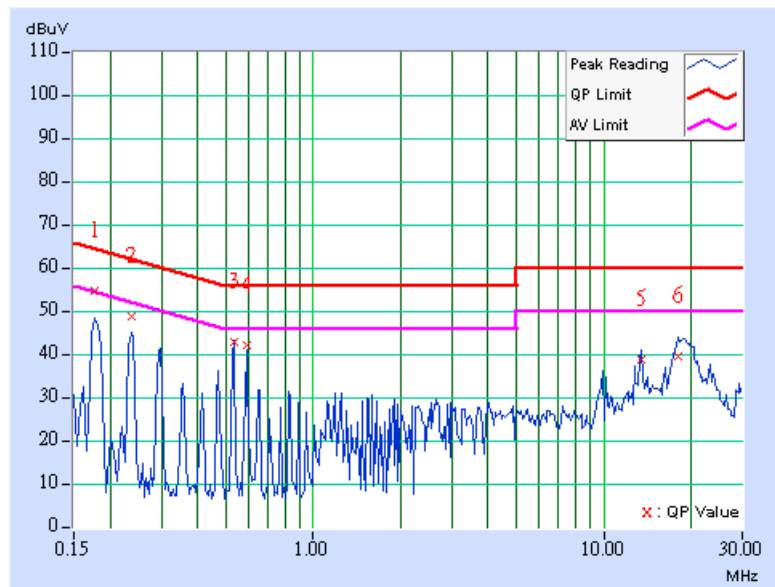



**Conducted Worst-Case Data (Power from AC Adapter: NU20-5120200-I2)**

<b>EUT</b>	VA4200 Wi-Fi AP/Bridge	<b>MEASUREMENT DETAIL</b>	
<b>MODEL</b>	VA4200	<b>PHASE</b>	Line 1
<b>CHANNEL</b>	Channel 1	<b>6dB BANDWIDTH</b>	9 kHz
<b>MODULATION TYPE</b>	BPSK	<b>ENVIRONMENTAL CONDITIONS</b>	23deg. C, 65%RH, 991hPa
<b>TRANSFER RATE</b>	6Mbps	<b>INPUT POWER (SYSTEM)</b>	120Vac, 60 Hz
<b>TEST MODE</b>	2	<b>TESTED BY</b>	Gary Chang

No	Freq. [MHz]	Corr. Factor (dB)	Reading Value		Emission Level		Limit		Margin	
			[dB (uV)]		[dB (uV)]		[dB (uV)]		(dB)	
			Q.P.	AV.	Q.P.	AV.	Q.P.	AV.	Q.P.	AV.
1	0.150	0.11	25.52	-	25.63	-	66.00	56.00	-40.37	-
2	0.197	0.11	38.03	-	38.14	-	63.74	53.74	-25.60	-
3	0.263	0.11	32.54	-	32.65	-	61.33	51.33	-28.68	-
4	0.392	0.11	26.78	-	26.89	-	58.02	48.02	-31.13	-
5	2.961	0.32	30.88	-	31.20	-	56.00	46.00	-24.80	-
6	8.813	0.51	28.88	-	29.39	-	60.00	50.00	-30.61	-

- REMARKS:**
1. Q.P. and AV. are abbreviations of quasi-peak and average individually.
  2. "-": The Quasi-peak reading value also meets average limit and measurement with the average detector is unnecessary.
  3. The emission levels of other frequencies were very low against the limit.
  4. Margin value = Emission level - Limit value
  5. Correction factor = Insertion loss + Cable loss
  6. Emission Level = Correction Factor + Reading Value.

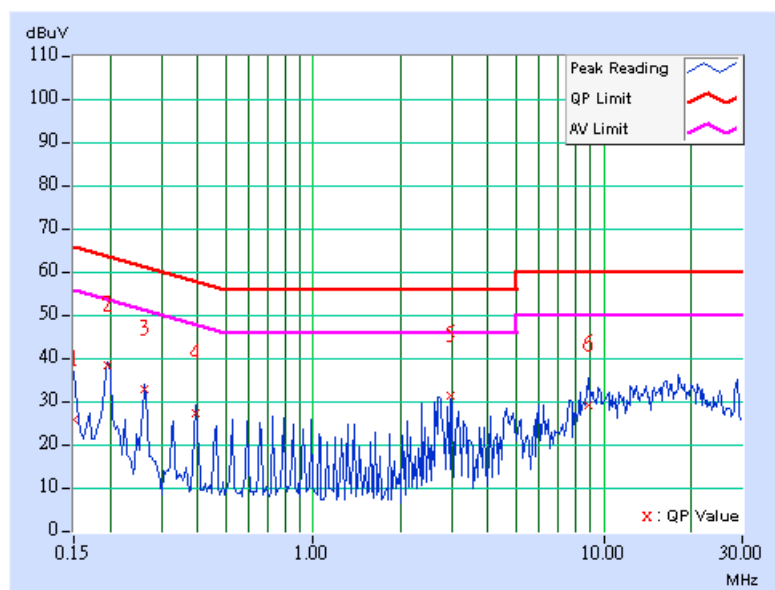



<b>EUT</b>	VA4200 Wi-Fi AP/Bridge	<b>MEASUREMENT DETAIL</b>	
<b>MODEL</b>	VA4200	<b>PHASE</b>	Line 2
<b>CHANNEL</b>	Channel 1	<b>6dB BANDWIDTH</b>	9 kHz
<b>MODULATION TYPE</b>	BPSK	<b>ENVIRONMENTAL CONDITIONS</b>	23deg. C, 65%RH, 991hPa
<b>TRANSFER RATE</b>	6Mbps	<b>INPUT POWER (SYSTEM)</b>	120Vac, 60 Hz
<b>TEST MODE</b>	2	<b>TESTED BY</b>	Gary Chang

No	Freq. [MHz]	Corr. Factor (dB)	Reading Value [dB (uV)]		Emission Level [dB (uV)]		Limit [dB (uV)]		Margin (dB)	
			Q.P.	AV.	Q.P.	AV.	Q.P.	AV.	Q.P.	AV.
			1	0.197	0.11	36.95	-	37.06	-	63.74
2	0.263	0.11	30.13	-	30.24	-	61.33	51.33	-31.09	-
3	0.459	0.12	27.50	-	27.62	-	56.72	46.72	-29.10	-
4	2.961	0.32	33.06	-	33.38	-	56.00	46.00	-22.62	-
5	4.871	0.40	28.91	-	29.31	-	56.00	46.00	-26.69	-
6	12.695	0.45	32.98	-	33.43	-	60.00	50.00	-26.57	-

- REMARKS:**
1. Q.P. and AV. are abbreviations of quasi-peak and average individually.
  2. "-": The Quasi-peak reading value also meets average limit and measurement with the average detector is unnecessary.
  3. The emission levels of other frequencies were very low against the limit.
  4. Margin value = Emission level - Limit value
  5. Correction factor = Insertion loss + Cable loss
  6. Emission Level = Correction Factor + Reading Value.

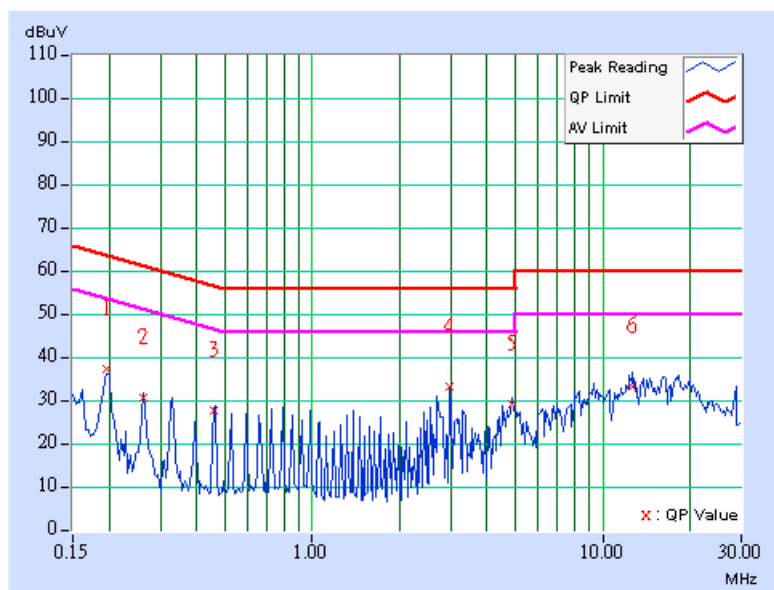



**Conducted Worst-Case Data (Power from POE)**

<b>EUT</b>	VA4200 Wi-Fi AP/Bridge	<b>MEASUREMENT DETAIL</b>	
<b>MODEL</b>	VA4200	<b>PHASE</b>	Line 1
<b>CHANNEL</b>	Channel 1	<b>6dB BANDWIDTH</b>	9 kHz
<b>MODULATION TYPE</b>	BPSK	<b>ENVIRONMENTAL CONDITIONS</b>	23deg. C, 65%RH, 991hPa
<b>TRANSFER RATE</b>	6Mbps	<b>INPUT POWER (SYSTEM)</b>	120Vac, 60 Hz
<b>TEST MODE</b>	3	<b>TESTED BY</b>	Gary Chang

No	Freq. [MHz]	Corr. Factor (dB)	Reading Value [dB (uV)]		Emission Level [dB (uV)]		Limit [dB (uV)]		Margin (dB)	
			Q.P.	AV.	Q.P.	AV.	Q.P.	AV.	Q.P.	AV.
			1	0.201	0.10	39.14	-	39.24	-	63.58
2	0.338	0.10	35.81	-	35.91	-	59.26	49.26	-23.35	-
3	0.470	0.11	36.02	-	36.13	-	56.51	46.51	-20.38	-
4	1.953	0.20	34.99	-	35.19	-	56.00	46.00	-20.81	-
5	22.527	0.95	41.42	-	42.37	-	60.00	50.00	-17.63	-
6	29.234	1.61	46.03	-	47.64	-	60.00	50.00	-12.36	-

- REMARKS:**
1. Q.P. and AV. are abbreviations of quasi-peak and average individually.
  2. "-": The Quasi-peak reading value also meets average limit and measurement with the average detector is unnecessary.
  3. The emission levels of other frequencies were very low against the limit.
  4. Margin value = Emission level - Limit value
  5. Correction factor = Insertion loss + Cable loss
  6. Emission Level = Correction Factor + Reading Value.

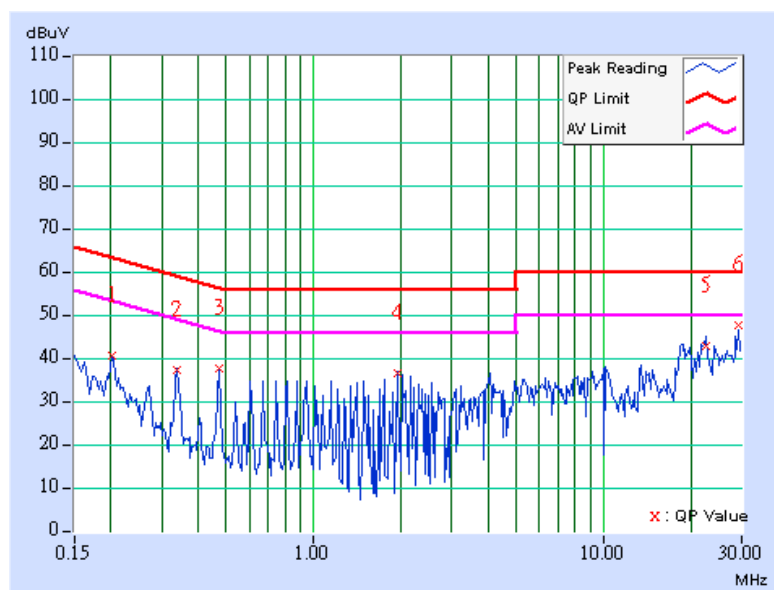



<b>EUT</b>	VA4200 Wi-Fi AP/Bridge	<b>MEASUREMENT DETAIL</b>	
<b>MODEL</b>	VA4200	<b>PHASE</b>	Line 2
<b>CHANNEL</b>	Channel 1	<b>6dB BANDWIDTH</b>	9 kHz
<b>MODULATION TYPE</b>	BPSK	<b>ENVIRONMENTAL CONDITIONS</b>	23deg. C, 65%RH, 991hPa
<b>TRANSFER RATE</b>	6Mbps	<b>INPUT POWER (SYSTEM)</b>	120Vac, 60 Hz
<b>TEST MODE</b>	3	<b>TESTED BY</b>	Gary Chang

No	Freq. [MHz]	Corr. Factor (dB)	Reading Value [dB (uV)]		Emission Level [dB (uV)]		Limit [dB (uV)]		Margin (dB)	
			Q.P.	AV.	Q.P.	AV.	Q.P.	AV.	Q.P.	AV.
			1	0.205	0.10	38.15	-	38.25	-	63.42
2	0.470	0.11	35.21	-	35.32	-	56.51	46.51	-21.19	-
3	2.020	0.20	34.09	-	34.29	-	56.00	46.00	-21.71	-
4	5.395	0.25	34.53	-	34.78	-	60.00	50.00	-25.22	-
5	19.758	0.79	41.69	-	42.48	-	60.00	50.00	-17.52	-
6	29.234	1.17	45.03	-	46.20	-	60.00	50.00	-13.80	-

- REMARKS:**
1. Q.P. and AV. are abbreviations of quasi-peak and average individually.
  2. "-": The Quasi-peak reading value also meets average limit and measurement with the average detector is unnecessary.
  3. The emission levels of other frequencies were very low against the limit.
  4. Margin value = Emission level - Limit value
  5. Correction factor = Insertion loss + Cable loss
  6. Emission Level = Correction Factor + Reading Value.

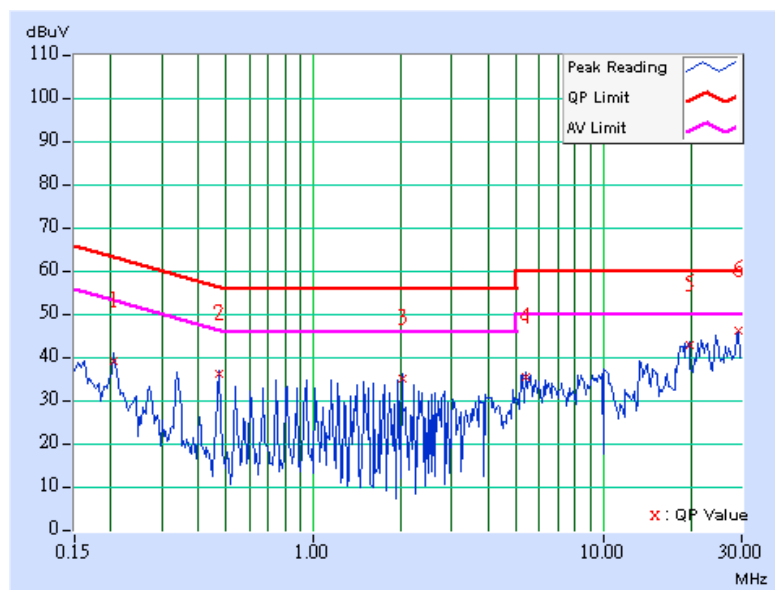



## 5.2 RADIATED EMISSION MEASUREMENT

### 5.2.1 LIMITS OF RADIATED EMISSION MEASUREMENT

Emissions radiated outside of the specified bands, shall be according to the general radiated limits in 15.209 as following:

Frequencies (MHz)	Field strength (microvolts/meter)	Measurement distance (meters)
0.009-0.490	2400/F(kHz)	300
0.490-1.705	24000/F(kHz)	30
1.705-30.0	30	30
30-88	100	3
88-216	150	3
216-960	200	3
Above 960	500	3

**NOTE:**

1. The lower limit shall apply at the transition frequencies.
2. Emission level (dBuV/m) = 20 log Emission level (uV/m).
3. As shown in 15.35(b), for frequencies above 1000MHz, the field strength limits are based on average detector, however, the peak field strength of any emission shall not exceed the maximum permitted average limits, specified above by more than 20dB under any condition of modulation.





## 5.2.2 TEST INSTRUMENTS

DESCRIPTION & MANUFACTURER	MODEL NO.	SERIAL NO.	CALIBRATED UNTIL
Test Receiver ROHDE & SCHWARZ	ESIB7	100188	Dec. 19, 2005
Spectrum Analyzer ROHDE & SCHWARZ	FSP40	100039	Nov. 21, 2005
BILOG Antenna SCHWARZBECK	VULB9168	9168-157	Jan. 22, 2006
HORN Antenna SCHWARZBECK	BBHA 9120 D	9120D-407	Jan. 16, 2006
HORN Antenna SCHWARZBECK	BBHA 9170	BBHA 9170241	Feb. 23, 2006
Preamplifier Agilent	8449B	3008A01961	Nov. 09, 2005
Preamplifier Agilent	8447D	2944A10629	Nov. 09, 2005
RF signal cable HUBER+SUHNER	SUCOFLEX 104	218182/4	Feb. 17, 2006
RF signal cable HUBER+SUHNER	SUCOFLEX 104	218194/4	Feb. 17, 2006
Software ADT.	ADT_Radiated_V5.14	NA	NA
Antenna Tower ADT.	AT100	AT93021702	NA
Turn Table ADT.	TT100.	TT93021702	NA
Controller ADT.	SC100.	SC93021702	NA

- NOTE:**
1. The calibration interval of the above test instruments is 12 months and the calibrations are traceable to NML/ROC and NIST/USA.
  2. The test was performed in HwaYa Chamber 1.
  3. The horn antenna and HP preamplifier (model: 8449B) are used only for the measurement of emission frequency above 1GHz if tested.
  4. The IC Site Registration No. is IC4924-2.



### 5.2.3 TEST PROCEDURES

- a. The EUT was placed on the top of a rotating table 0.8 meters above the ground at a 3 meter semi-anechoic chamber. The table was rotated 360 degrees to determine the position of the highest radiation.
- b. The EUT was set 3 meters away from the interference-receiving antenna, which was mounted on the top of a variable-height antenna tower.
- c. The antenna is a broadband antenna, and its height is varied from one meter to four meters above the ground to determine the maximum value of the field strength. Both horizontal and vertical polarizations of the antenna are set to make the measurement.
- d. For each suspected emission, the EUT was arranged to its worst case and then the antenna was tuned to heights from 1 meter to 4 meters and the rotatable table was turned from 0 degrees to 360 degrees to find the maximum reading.
- e. The test-receiver system was set to Peak Detect Function and Specified Bandwidth with Maximum Hold Mode.
- f. If the emission level of the EUT in peak mode was lower than the limit specified, then testing could be stopped and the peak values of the EUT would be reported. Otherwise the emissions would be re-tested one by one using peak, quasi-peak or average method as specified and then reported in a data sheet.

**NOTE:**

1. The resolution bandwidth and video bandwidth of test receiver/spectrum analyzer is 120kHz for Peak detection (PK) and Quasi-peak detection (QP) at frequency below 1GHz.
2. The resolution bandwidth and video bandwidth of test receiver/spectrum analyzer is 1 MHz for Peak detection at frequency above 1GHz.
3. The resolution bandwidth of test receiver/spectrum analyzer is 1 MHz and the video bandwidth is 10 Hz for Average detection (AV) at frequency above 1GHz.

### 5.2.4 DEVIATION FROM TEST STANDARD

No deviation

### 5.2.5 TEST SETUP

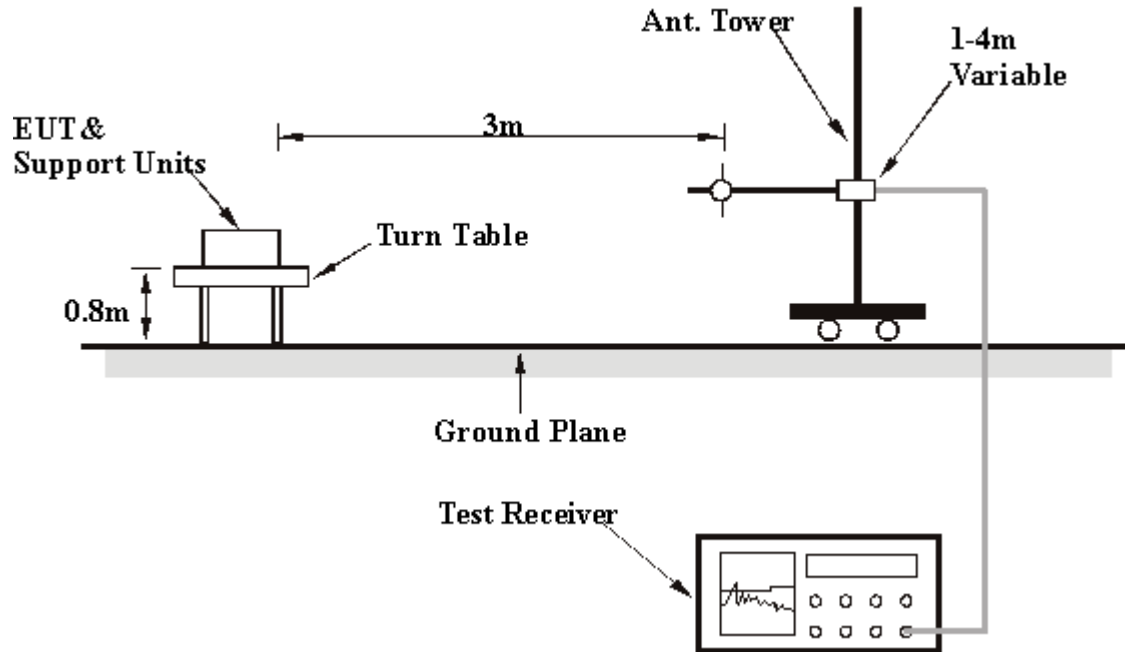

For the actual test configuration, please refer to the related item – Photographs of the Test Configuration.

### 5.2.6 EUT OPERATING CONDITIONS

Same as 4.1.6

## 5.2.7 TEST RESULTS

## Below 1GHz Worst-Case Data (Power from AC Adapter: RHE-120150-7)

<b>EUT</b>	VA4200 Wi-Fi AP/Bridge	<b>MEASUREMENT DETAIL</b>	
<b>MODEL</b>	VA4200	<b>FREQUENCY RANGE</b>	Below 1000MHz
<b>CHANNEL</b>	Channel 1	<b>DETECTOR FUNCTION</b>	Quasi-Peak
<b>MODULATION TYPE</b>	BPSK	<b>ENVIRONMENTAL CONDITIONS</b>	21deg. C, 70%RH, 991hPa
<b>TRANSFER RATE</b>	6Mbps	<b>INPUT POWER (SYSTEM)</b>	120Vac, 60 Hz
<b>TEST MODE</b>	1	<b>TESTED BY</b>	Match Tsui

**ANTENNA POLARITY & TEST DISTANCE: HORIZONTAL AT 3 M**

No.	Freq. (MHz)	Emission Level (dBuV/m)	Limit (dBuV/m)	Margin (dB)	Antenna Height (m)	Table Angle (Degree)	Raw Value (dBuV)	Correction Factor (dB/m)
1	114.28	36.28 QP	43.50	-7.22	1.75 H	300	24.07	12.21
2	166.28	37.25 QP	43.50	-6.25	2.00 H	177	23.20	14.05
3	200.10	40.89 QP	43.50	-2.61	1.00 H	239	29.76	11.13
4	250.18	44.11 QP	46.00	-1.89	1.25 H	147	31.02	13.09
5	399.34	42.66 QP	46.00	-3.34	1.00 H	319	26.04	16.62
6	432.38	36.97 QP	46.00	-9.03	1.00 H	28	19.51	17.46
7	534.10	38.48 QP	46.00	-7.52	1.00 H	269	19.20	19.28
8	667.60	37.31 QP	46.00	-8.69	1.00 H	1	15.49	21.82
9	800.31	40.48 QP	46.00	-5.52	1.25 H	56	16.78	23.70
10	934.10	43.52 QP	46.00	-2.48	1.50 H	289	18.07	25.45

**ANTENNA POLARITY & TEST DISTANCE: VERTICAL AT 3 M**

No.	Freq. (MHz)	Emission Level (dBuV/m)	Limit (dBuV/m)	Margin (dB)	Antenna Height (m)	Table Angle (Degree)	Raw Value (dBuV)	Correction Factor (dB/m)
1	32.14	33.28 QP	40.00	-6.72	1.25 V	162	19.57	13.71
2	65.17	35.14 QP	40.00	-4.86	1.00 V	169	22.26	12.88
3	105.81	38.21 QP	43.50	-5.29	1.00 V	73	26.87	11.34
4	166.28	41.52 QP	43.50	-1.98	1.25 V	169	27.47	14.05
5	199.12	36.84 QP	43.50	-6.66	1.25 V	169	25.64	11.20
6	249.66	40.72 QP	46.00	-5.28	1.50 V	22	27.64	13.08
7	400.25	38.41 QP	46.00	-7.59	1.25 V	289	21.77	16.64
8	599.56	37.04 QP	46.00	-8.96	1.50 V	10	16.16	20.88
9	668.18	36.87 QP	46.00	-9.13	1.50 V	287	15.04	21.83
10	933.44	44.28 QP	46.00	-1.72	1.25 V	360	18.84	25.44

- REMARKS:**
1. Emission level(dBuV/m)=Raw Value(dBuV) + Correction Factor(dB/m)
  2. Correction Factor(dB/m) = Antenna Factor (dB/m) + Cable Factor (dB)
  3. The other emission levels were very low against the limit.
  4. Margin value = Emission level – Limit value

**Below 1GHz Worst-Case Data (Power from AC Adapter: NU20-5120200-I2)**

<b>EUT</b>	VA4200 Wi-Fi AP/Bridge	<b>MEASUREMENT DETAIL</b>	
<b>MODEL</b>	VA4200	<b>FREQUENCY RANGE</b>	Below 1000MHz
<b>CHANNEL</b>	Channel 1	<b>DETECTOR FUNCTION</b>	Quasi-Peak
<b>MODULATION TYPE</b>	BPSK	<b>ENVIRONMENTAL CONDITIONS</b>	25deg. C, 68%RH, 991hPa
<b>TRANSFER RATE</b>	6Mbps	<b>INPUT POWER (SYSTEM)</b>	120Vac, 60 Hz
<b>TEST MODE</b>	2	<b>TESTED BY</b>	Match Tsui

**ANTENNA POLARITY & TEST DISTANCE: HORIZONTAL AT 3 M**

No.	Freq. (MHz)	Emission Level (dBuV/m)	Limit (dBuV/m)	Margin (dB)	Antenna Height (m)	Table Angle (Degree)	Raw Value (dBuV)	Correction Factor (dB/m)
1	105.81	40.96 QP	43.50	-2.54	2.50 H	55	29.62	11.34
2	166.07	41.53 QP	43.50	-1.97	1.50 H	67	27.46	14.07
3	199.12	35.65 QP	43.50	-7.85	1.50 H	7	24.45	11.20
4	249.66	44.07 QP	46.00	-1.93	1.00 H	193	30.99	13.08
5	333.25	38.52 QP	46.00	-7.48	1.00 H	319	23.44	15.08
6	366.29	38.73 QP	46.00	-7.27	1.00 H	301	22.89	15.84
7	399.34	44.10 QP	46.00	-1.90	1.00 H	289	27.48	16.62
8	533.47	37.17 QP	46.00	-8.83	1.50 H	28	17.90	19.27
9	599.56	36.90 QP	46.00	-9.10	1.50 H	331	16.02	20.88
10	667.60	39.77 QP	46.00	-6.23	1.00 H	7	17.95	21.82
11	799.78	40.06 QP	46.00	-5.94	1.00 H	10	16.36	23.70
12	933.91	42.39 QP	46.00	-3.61	1.50 H	352	16.94	25.45

**ANTENNA POLARITY & TEST DISTANCE: VERTICAL AT 3 M**

No.	Freq. (MHz)	Emission Level (dBuV/m)	Limit (dBuV/m)	Margin (dB)	Antenna Height (m)	Table Angle (Degree)	Raw Value (dBuV)	Correction Factor (dB/m)
1	57.21	34.28 QP	40.00	-5.72	1.00 V	22	20.55	13.74
2	105.81	34.88 QP	43.50	-8.62	1.00 V	280	23.54	11.34
3	166.07	32.32 QP	43.50	-11.18	1.00 V	106	18.25	14.07
4	249.66	34.59 QP	46.00	-11.41	1.50 V	121	21.51	13.08
5	399.34	38.52 QP	46.00	-7.48	2.00 V	322	21.90	16.62
6	467.37	33.18 QP	46.00	-12.82	1.00 V	211	15.04	18.15
7	533.47	34.88 QP	46.00	-11.12	1.50 V	295	15.61	19.27
8	667.60	38.17 QP	46.00	-7.83	1.50 V	340	16.35	21.82
9	799.78	33.98 QP	46.00	-12.02	1.50 V	40	10.28	23.70
10	933.91	41.45 QP	46.00	-4.55	1.00 V	322	16.00	25.45

- REMARKS:**
1. Emission level(dBuV/m)=Raw Value(dBuV) + Correction Factor(dB/m)
  2. Correction Factor(dB/m) = Antenna Factor (dB/m) + Cable Factor (dB)
  3. The other emission levels were very low against the limit.
  4. Margin value = Emission level – Limit value



### Below 1GHz Worst-Case Data (Power from POE)

<b>EUT</b>	VA4200 Wi-Fi AP/Bridge	<b>MEASUREMENT DETAIL</b>	
<b>MODEL</b>	VA4200	<b>FREQUENCY RANGE</b>	Below 1000MHz
<b>CHANNEL</b>	Channel 1	<b>DETECTOR FUNCTION</b>	Quasi-Peak
<b>MODULATION TYPE</b>	BPSK	<b>ENVIRONMENTAL CONDITIONS</b>	25deg. C, 68%RH, 991hPa
<b>TRANSFER RATE</b>	6Mbps	<b>INPUT POWER (SYSTEM)</b>	120Vac, 60 Hz
<b>TEST MODE</b>	3	<b>TESTED BY</b>	Match Tsui

#### ANTENNA POLARITY & TEST DISTANCE: HORIZONTAL AT 3 M

No.	Freq. (MHz)	Emission Level (dBuV/m)	Limit (dBuV/m)	Margin (dB)	Antenna Height (m)	Table Angle (Degree)	Raw Value (dBuV)	Correction Factor (dB/m)
1	44.10	37.11 QP	40.00	-2.89	1.75 H	144	22.07	15.04
2	95.40	37.11 QP	43.50	-6.39	2.00 H	174	26.73	10.38
3	142.75	38.56 QP	43.50	-4.94	1.00 H	7	24.29	14.27
4	199.12	35.03 QP	43.50	-8.47	1.00 H	298	23.83	11.20
5	249.66	44.11 QP	46.00	-1.89	1.00 H	285	31.03	13.08
6	300.14	38.11 QP	46.00	-7.89	1.25 H	111	23.78	14.33
7	399.34	40.61 QP	46.00	-5.39	1.00 H	166	23.99	16.62
8	500.42	38.46 QP	46.00	-7.54	1.50 H	355	19.87	18.59
9	599.56	38.13 QP	46.00	-7.87	1.50 H	121	17.25	20.88
10	668.10	39.14 QP	46.00	-6.86	1.00 H	122	17.31	21.83
11	799.78	37.02 QP	46.00	-8.98	1.00 H	1	13.32	23.70
12	933.91	41.97 QP	46.00	-4.03	1.50 H	334	16.52	25.45

#### ANTENNA POLARITY & TEST DISTANCE: VERTICAL AT 3 M

No.	Freq. (MHz)	Emission Level (dBuV/m)	Limit (dBuV/m)	Margin (dB)	Antenna Height (m)	Table Angle (Degree)	Raw Value (dBuV)	Correction Factor (dB/m)
1	44.10	37.96 QP	40.00	-2.04	1.00 V	31	22.92	15.04
2	105.81	41.50 QP	43.50	-2.00	1.00 V	244	30.16	11.34
3	142.75	38.34 QP	43.50	-5.16	1.00 V	58	24.06	14.27
4	250.17	42.40 QP	46.00	-3.60	1.50 V	177	29.31	13.09
5	399.34	37.47 QP	46.00	-8.53	1.75 V	307	20.85	16.62
6	500.42	39.11 QP	46.00	-6.89	1.25 V	127	20.52	18.59
7	667.60	36.85 QP	46.00	-9.15	1.00 V	274	15.03	21.82
8	933.28	44.28 QP	46.00	-1.72	1.25 V	144	18.84	25.44

- REMARKS:**
1. Emission level(dBuV/m)=Raw Value(dBuV) + Correction Factor(dB/m)
  2. Correction Factor(dB/m) = Antenna Factor (dB/m) + Cable Factor (dB)
  3. The other emission levels were very low against the limit.
  4. Margin value = Emission level – Limit value

**802.11a OFDM modulation**

<b>EUT</b>	VA4200 Wi-Fi AP/Bridge	<b>MEASUREMENT DETAIL</b>	
<b>MODEL</b>	VA4200	<b>FREQUENCY RANGE</b>	1 ~ 40 GHz
<b>CHANNEL</b>	Channel 1	<b>DETECTOR FUNCTION</b>	Peak(PK) Average (AV)
<b>MODULATION TYPE</b>	BPSK	<b>ENVIRONMENTAL CONDITIONS</b>	25deg. C, 68%RH, 991hPa
<b>TRANSFER RATE</b>	6Mbps	<b>INPUT POWER (SYSTEM)</b>	120Vac, 60 Hz
<b>TESTED BY</b>	Match Tsui		

**ANTENNA POLARITY & TEST DISTANCE: HORIZONTAL AT 3 M**

No.	Freq. (MHz)	Emission Level (dBuV/m)	Limit (dBuV/m)	Margin (dB)	Antenna Height (m)	Table Angle (Degree)	Raw Value (dBuV)	Correction Factor (dB/m)
1	#1066.00	44.04 PK	74.00	-29.96	1.00 H	360	17.28	26.76
1	#1066.00	38.20 AV	54.00	-15.80	1.00 H	360	11.44	26.76
2	*5745.00	106.58 PK			1.07 H	164	68.52	38.06
2	*5745.00	97.42 AV			1.07 H	164	59.36	38.06
3	#11490.00	56.85 PK	74.00	-17.15	1.16 H	30	9.62	47.23
3	#11490.00	44.83 AV	54.00	-9.17	1.16 H	30	-2.40	47.23

**ANTENNA POLARITY & TEST DISTANCE: VERTICAL AT 3 M**

No.	Freq. (MHz)	Emission Level (dBuV/m)	Limit (dBuV/m)	Margin (dB)	Antenna Height (m)	Table Angle (Degree)	Raw Value (dBuV)	Correction Factor (dB/m)
1	#1066.00	44.23 PK	74.00	-29.77	1.03 V	275	17.47	26.76
1	#1066.00	44.21 AV	54.00	-9.79	1.03 V	275	17.45	26.76
2	*5745.00	111.40 PK			1.05 V	160	73.34	38.06
2	*5745.00	101.10 AV			1.05 V	160	63.04	38.06
3	#11490.00	59.86 PK	74.00	-14.14	1.29 V	256	12.63	47.23
3	#11490.00	47.25 AV	54.00	-6.75	1.29 V	256	0.02	47.23

- NOTE:**
1. Emission level(dBuV/m)=Raw Value(dBuV) + Correction Factor(dB/m)
  2. Correction Factor(dB/m) = Antenna Factor (dB/m) + Cable Factor (dB)
  3. The other emission levels were very low against the limit.
  4. Margin value = Emission level – Limit value
  5. "\*" : Fundamental frequency
  6. "#"The radiated frequency falling in the restricted band.
  7. The limit value is defined as per 15.247



<b>EUT</b>	VA4200 Wi-Fi AP/Bridge	<b>MEASUREMENT DETAIL</b>	
<b>MODEL</b>	VA4200	<b>FREQUENCY RANGE</b>	1 ~ 40 GHz
<b>CHANNEL</b>	Channel 3	<b>DETECTOR FUNCTION</b>	Peak(PK) Average (AV)
<b>MODULATION TYPE</b>	BPSK	<b>ENVIRONMENTAL CONDITIONS</b>	25deg. C, 68%RH, 991hPa
<b>TRANSFER RATE</b>	6Mbps	<b>INPUT POWER (SYSTEM)</b>	120Vac, 60 Hz
<b>TESTED BY</b>	Match Tsui		

#### ANTENNA POLARITY & TEST DISTANCE: HORIZONTAL AT 3 M

No.	Freq. (MHz)	Emission Level (dBuV/m)	Limit (dBuV/m)	Margin (dB)	Antenna Height (m)	Table Angle (Degree)	Raw Value (dBuV)	Correction Factor (dB/m)
1	#1066.00	47.20 PK	74.00	-26.80	1.41 H	50	20.44	26.76
1	#1066.00	41.80 AV	54.00	-12.20	1.41 H	50	15.04	26.76
2	*5785.00	106.70 PK			1.05 H	183	68.55	38.15
2	*5785.00	97.53 AV			1.05 H	183	59.38	38.15
3	#11570.00	56.72 PK	74.00	-17.28	1.24 H	253	9.60	47.12
3	#11570.00	44.17 AV	54.00	-9.83	1.24 H	253	-2.95	47.12

#### ANTENNA POLARITY & TEST DISTANCE: VERTICAL AT 3 M

No.	Freq. (MHz)	Emission Level (dBuV/m)	Limit (dBuV/m)	Margin (dB)	Antenna Height (m)	Table Angle (Degree)	Raw Value (dBuV)	Correction Factor (dB/m)
1	#1066.00	44.80 PK	74.00	-29.20	1.08 V	300	18.04	26.76
1	#1066.00	46.80 AV	54.00	-7.20	1.08 V	300	20.04	26.76
2	*5785.00	111.10 PK			1.07 V	200	72.95	38.15
2	*5785.00	100.50 AV			1.07 V	200	62.35	38.15
3	#11570.00	61.57 PK	74.00	-12.43	1.30 V	286	14.45	47.12
3	#11570.00	48.59 AV	54.00	-5.41	1.30 V	286	1.47	47.12

- NOTE:**
1. Emission level(dBuV/m)=Raw Value(dBuV) + Correction Factor(dB/m)
  2. Correction Factor(dB/m) = Antenna Factor (dB/m) + Cable Factor (dB)
  3. The other emission levels were very low against the limit.
  4. Margin value = Emission level – Limit value
  5. "\*" : Fundamental frequency
  6. "#"The radiated frequency falling in the restricted band.
  7. The limit value is defined as per 15.247





<b>EUT</b>	VA4200 Wi-Fi AP/Bridge	<b>MEASUREMENT DETAIL</b>	
<b>MODEL</b>	VA4200	<b>FREQUENCY RANGE</b>	1 ~ 40 GHz
<b>CHANNEL</b>	Channel 5	<b>DETECTOR FUNCTION</b>	Peak(PK) Average (AV)
<b>MODULATION TYPE</b>	BPSK	<b>ENVIRONMENTAL CONDITIONS</b>	25deg. C, 68%RH, 991hPa
<b>TRANSFER RATE</b>	6Mbps	<b>INPUT POWER (SYSTEM)</b>	120Vac, 60 Hz
<b>TESTED BY</b>	Match Tsui		

#### ANTENNA POLARITY & TEST DISTANCE: HORIZONTAL AT 3 M

No.	Freq. (MHz)	Emission Level (dBuV/m)	Limit (dBuV/m)	Margin (dB)	Antenna Height (m)	Table Angle (Degree)	Raw Value (dBuV)	Correction Factor (dB/m)
1	#1066.00	47.00 PK	74.00	-27.00	1.39 H	57	20.24	26.76
1	#1066.00	42.80 AV	54.00	-11.20	1.39 H	57	16.04	26.76
2	*5825.00	107.50 PK			1.05 H	165	69.29	38.21
2	*5825.00	98.30 AV			1.05 H	165	60.09	38.21
3	#11650.00	54.72 PK	74.00	-19.28	1.24 H	253	7.62	47.10
3	#11650.00	42.17 AV	54.00	-11.83	1.24 H	253	-4.93	47.10

#### ANTENNA POLARITY & TEST DISTANCE: VERTICAL AT 3 M

No.	Freq. (MHz)	Emission Level (dBuV/m)	Limit (dBuV/m)	Margin (dB)	Antenna Height (m)	Table Angle (Degree)	Raw Value (dBuV)	Correction Factor (dB/m)
1	#1066.00	49.42 PK	74.00	-24.58	1.00 V	275	22.66	26.76
1	#1066.00	45.20 AV	54.00	-8.80	1.00 V	275	18.44	26.76
2	*5825.00	111.46 PK			1.02 V	327	73.25	38.21
2	*5825.00	102.30 AV			1.02 V	327	64.09	38.21
3	#11650.00	60.68 PK	74.00	-13.32	1.23 V	225	13.58	47.10
3	#11650.00	48.25 AV	54.00	-5.75	1.23 V	225	1.15	47.10

- NOTE:**
1. Emission level(dBuV/m)=Raw Value(dBuV) + Correction Factor(dB/m)
  2. Correction Factor(dB/m) = Antenna Factor (dB/m) + Cable Factor (dB)
  3. The other emission levels were very low against the limit.
  4. Margin value = Emission level – Limit value
  5. "\*" : Fundamental frequency
  6. "#"The radiated frequency falling in the restricted band.
  7. The limit value is defined as per 15.247



### 5.3 6dB BANDWIDTH MEASUREMENT

#### 5.3.1 LIMITS OF 6dB BANDWIDTH MEASUREMENT

The minimum of 6dB Bandwidth Measurement is 0.5 MHz.

#### 5.3.2 TEST INSTRUMENTS

Description & Manufacturer	Model No.	Serial No.	Calibrated Until
R&S SPECTRUM ANALYZER	FSEK30	100049	Aug. 12, 2005

**NOTES:** The calibration interval of the above test instruments is 12 months and the calibrations are traceable to NML/ROC and NIST/USA.

### 5.3.3 TEST PROCEDURE

The transmitter output was connected to the spectrum analyzer through an attenuator. The bandwidth of the fundamental frequency was measured by spectrum analyzer with 100kHz RBW and 100kHz VBW. The 6dB bandwidth is defined as the total spectrum the power of which is higher than peak power minus 6dB.

### 5.3.4 DEVIATION FROM TEST STANDARD

No deviation

### 5.3.5 TEST SETUP

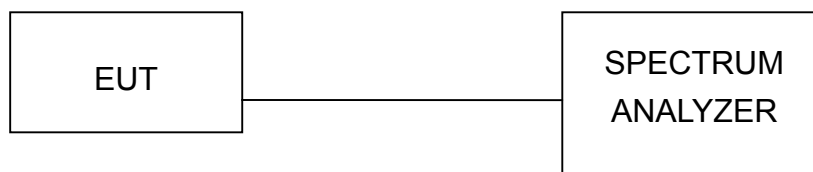

### 5.3.6 EUT OPERATING CONDITIONS

The software provided by client to enable the EUT under transmission condition continuously at lowest, middle and highest channel frequencies individually.

## 5.3.7 TEST RESULTS

**802.11a OFDM modulation**

<b>EUT</b>	VA4200 Wi-Fi AP/Bridge	<b>MODEL</b>	VA4200
<b>MODULATION TYPE</b>	BPSK	<b>TRANSFER RATE</b>	6Mbps
<b>INPUT POWER (SYSTEM)</b>	120Vac, 60 Hz	<b>ENVIRONMENTAL CONDITIONS</b>	25deg.C, 63%RH, 991hPa
<b>TESTED BY</b>	Long Chen		

<b>CHANNEL</b>	<b>CHANNEL FREQUENCY (MHz)</b>	<b>6dB BANDWIDTH (MHz)</b>	<b>MINIMUM LIMIT (MHz)</b>	<b>PASS/FAIL</b>
1	5745	16.60	0.5	PASS
3	5785	16.60	0.5	PASS
5	5825	16.56	0.5	PASS



CH 1

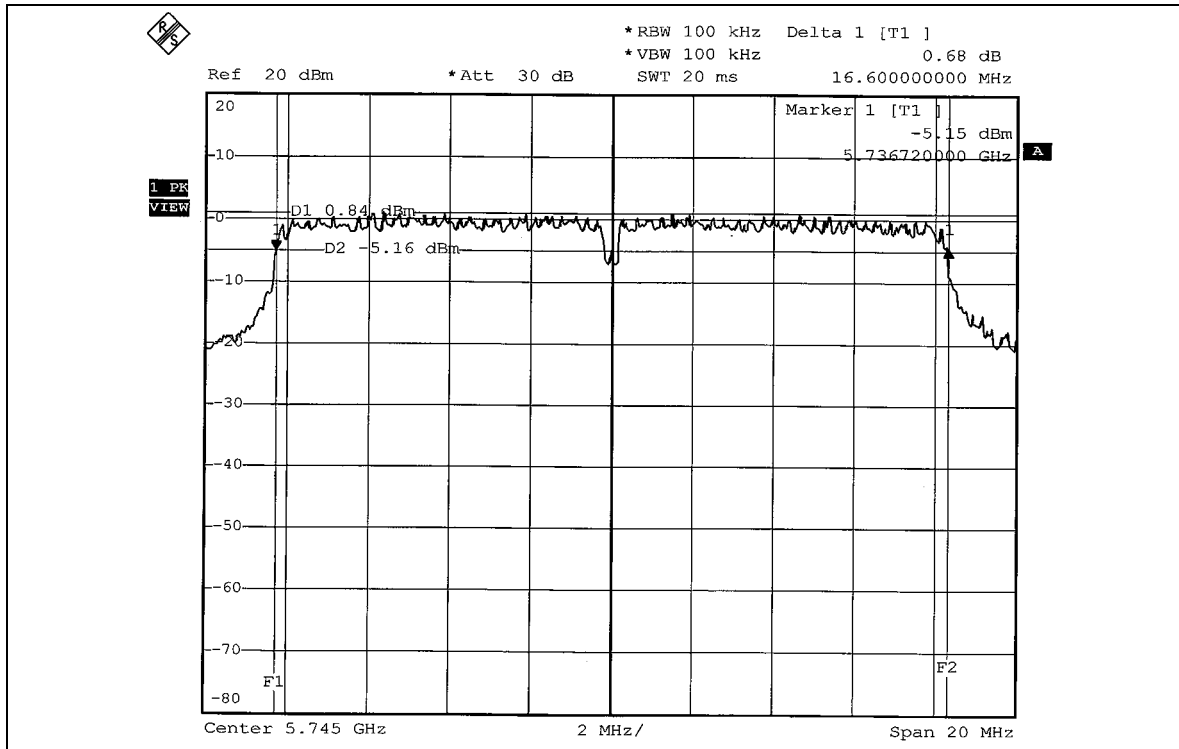

CH 3

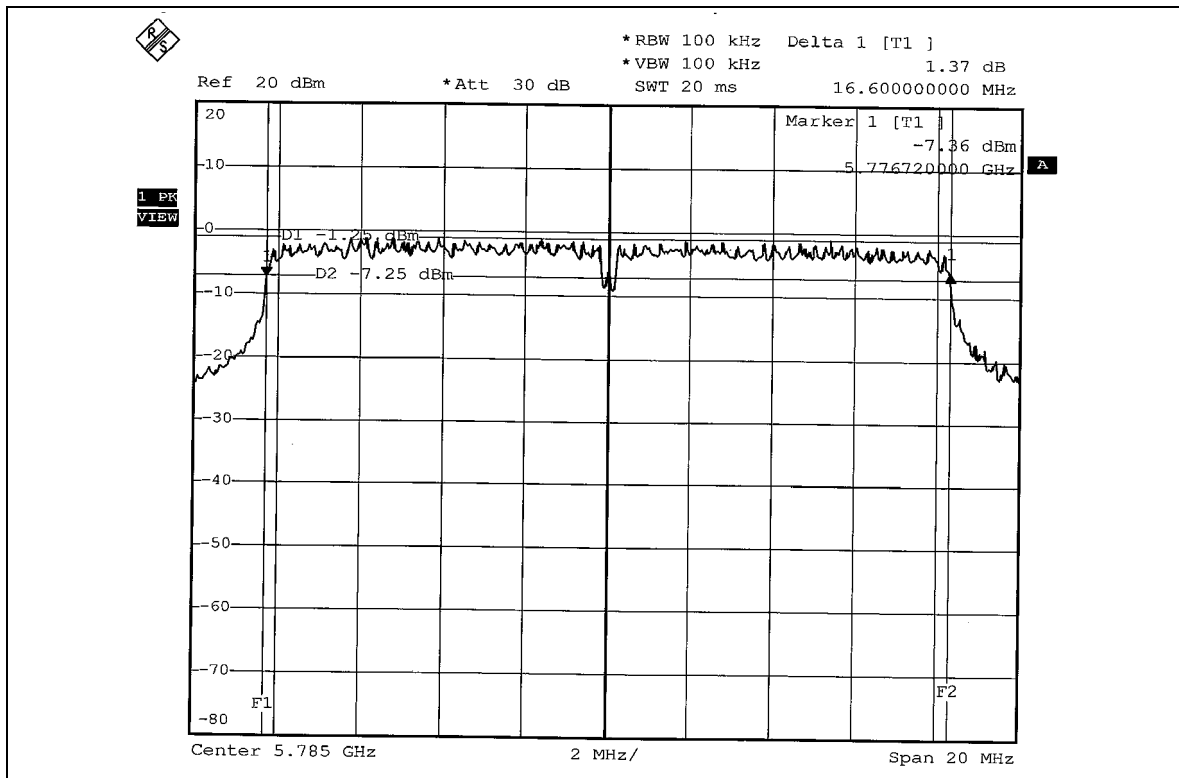



CH 5

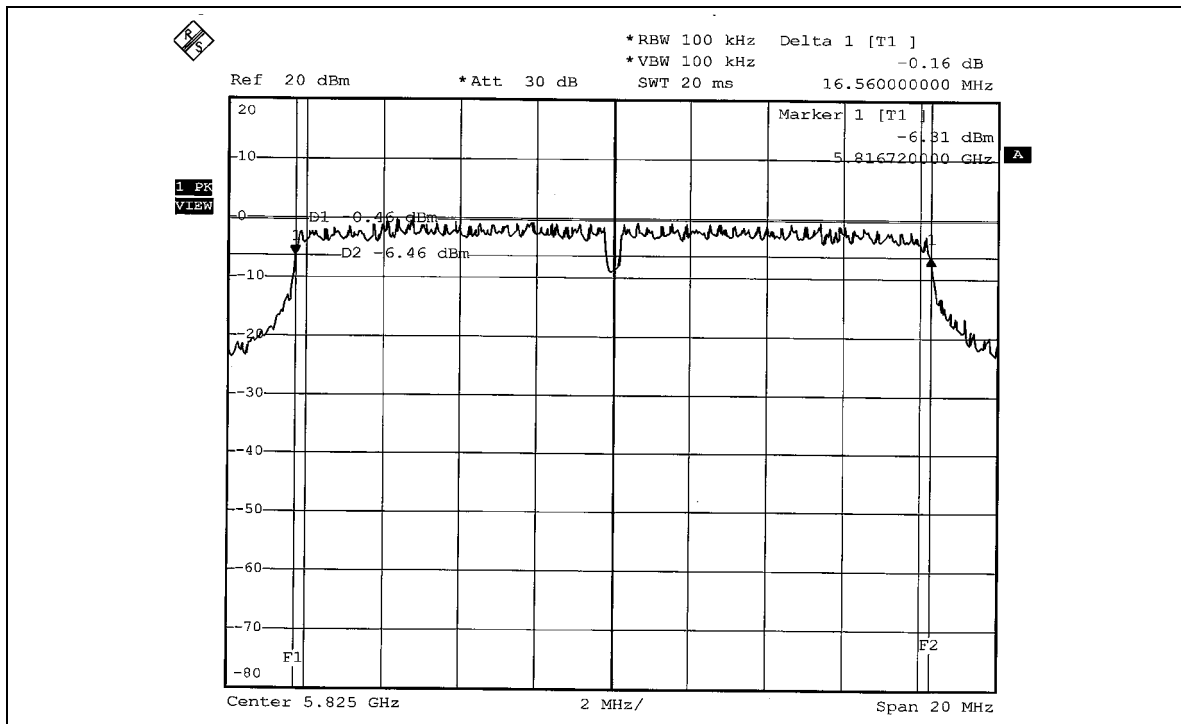



## 5.4 MAXIMUM PEAK OUTPUT POWER

### 5.4.1 LIMITS OF MAXIMUM PEAK OUTPUT POWER MEASUREMENT

The Maximum Peak Output Power Measurement is 30dBm.

### 5.4.2 INSTRUMENTS

Description & Manufacturer	Model No.	Serial No.	Calibrated Until
R&S SPECTRUM ANALYZER	FSEK30	100049	Aug. 12, 2005
AGILENT SIGNAL GENERATOR	E8257C	MY43320668	Dec. 31, 2005
TEKTRONIX OSCILLOSCOPE	TDS 1012	C019167	Feb. 01, 2006
NARDA DETECTOR	4503A	FSCM99899	NA

**NOTE:**

The calibration interval of the above test instruments is 12 months and the calibrations are traceable to NML/ROC and NIST/USA..

### 5.4.3 TEST PROCEDURES

1. A detector was used on the output port of the EUT. An oscilloscope was used to read the response of the detector.
2. Replaced the EUT by the signal generator . The center frequency of the S.G was adjusted to the center frequency of the measured channel.
3. Adjusted the power to have the same reading on oscilloscope. Record the power level.

### 5.4.4 DEVIATION FROM TEST STANDARD

No deviation

### 5.4.5 TEST SETUP



### 5.4.6 EUT OPERATING CONDITIONS

Same as Item 5.3.6





## 5.4.7 TEST RESULTS

**802.11a OFDM modulation**

<b>EUT</b>	VA4200 Wi-Fi AP/Bridge	<b>MODEL</b>	VA4200
<b>MODULATION TYPE</b>	BPSK	<b>TRANSFER RATE</b>	6Mbps
<b>INPUT POWER (SYSTEM)</b>	120Vac, 60 Hz	<b>ENVIRONMENTAL CONDITIONS</b>	25deg.C, 63%RH, 991hPa
<b>TESTED BY</b>	Long Chen		

<b>CHANNEL</b>	<b>CHANNEL FREQUENCY (MHz)</b>	<b>PEAK POWER OUTPUT (mW)</b>	<b>PEAK POWER OUTPUT (dBm)</b>	<b>PEAK POWER LIMIT (dBm)</b>	<b>PASS/FAIL</b>
1	5745	70.958	18.51	30	PASS
3	5785	63.533	18.03	30	PASS
5	5825	63.680	18.04	30	PASS



## 5.5 POWER SPECTRAL DENSITY MEASUREMENT

### 5.5.1 LIMITS OF POWER SPECTRAL DENSITY MEASUREMENT

The Maximum of Power Spectral Density Measurement is 8dBm.

### 5.5.2 TEST INSTRUMENTS

Description & Manufacturer	Model No.	Serial No.	Calibrated Until
R&S SPECTRUM ANALYZER	FSEK30	100049	Aug. 12, 2005

**NOTES:**

The calibration interval of the above test instruments is 12 months and the calibrations are traceable to NML/ROC and NIST/USA.

### 5.5.3 TEST PROCEDURE

The transmitter output was connected to the spectrum analyzer through an attenuator, the bandwidth of the fundamental frequency was measured with the spectrum analyzer using 3 kHz RBW and 30 kHz VBW, set sweep time = span/3 kHz. The power spectral density was measured and recorded.

The sweep time is allowed to be longer than span/3 kHz for a full response of the mixer in the spectrum analyzer.

### 5.5.4 DEVIATION FROM TEST STANDARD

No deviation

### 5.5.5 TEST SETUP

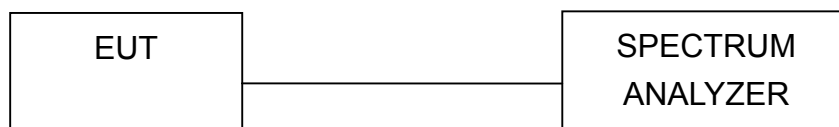

### 5.5.6 EUT OPERATING CONDITION

Same as Item 5.3.6



## 5.5.7 TEST RESULTS

**802.11a OFDM modulation**

<b>EUT</b>	VA4200 Wi-Fi AP/Bridge	<b>MODEL</b>	VA4200
<b>MODULATION TYPE</b>	BPSK	<b>TRANSFER RATE</b>	6Mbps
<b>INPUT POWER (SYSTEM)</b>	120Vac, 60 Hz	<b>ENVIRONMENTAL CONDITIONS</b>	25deg.C, 63%RH, 991hPa
<b>TESTED BY</b>	Long Chen		

<b>CHANNEL</b>	<b>CHANNEL FREQUENCY (MHz )</b>	<b>RF POWER LEVEL IN 3 kHz BW (dBm)</b>	<b>MAXIMUM LIMIT (dBm)</b>	<b>PASS/FAIL</b>
1	5745	-11.29	8	PASS
3	5785	-11.77	8	PASS
5	5825	-11.37	8	PASS



CH 1

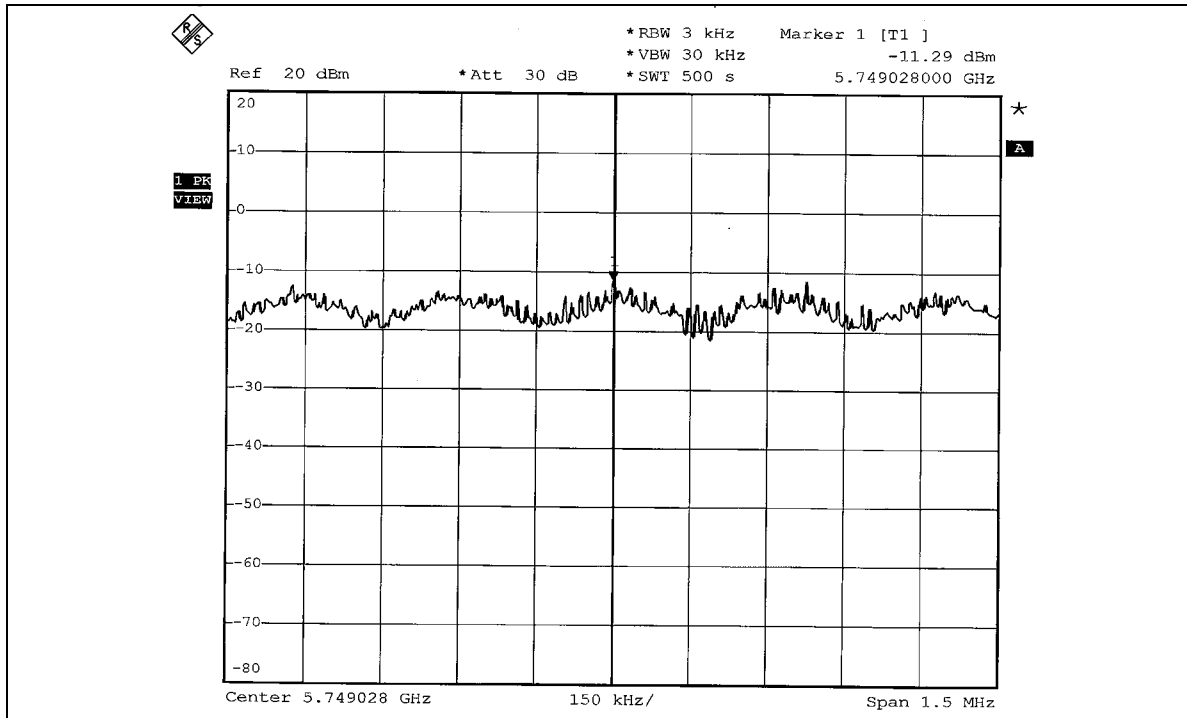

CH 3

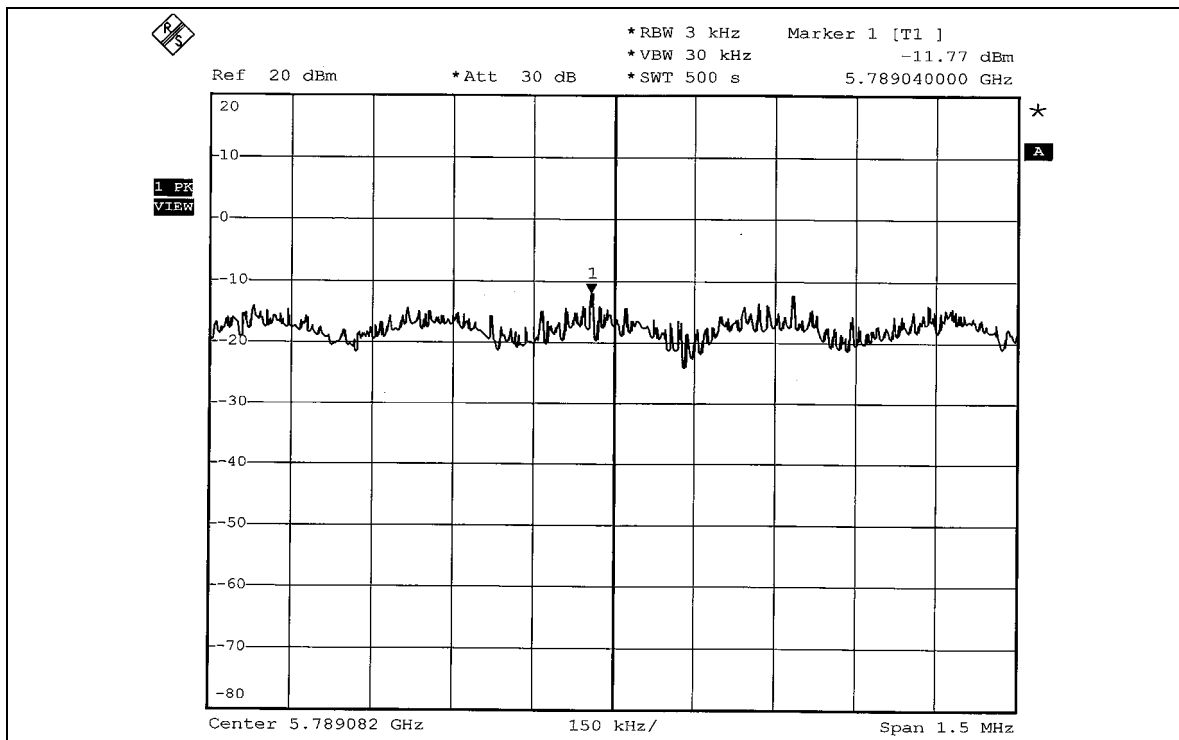



CH 4

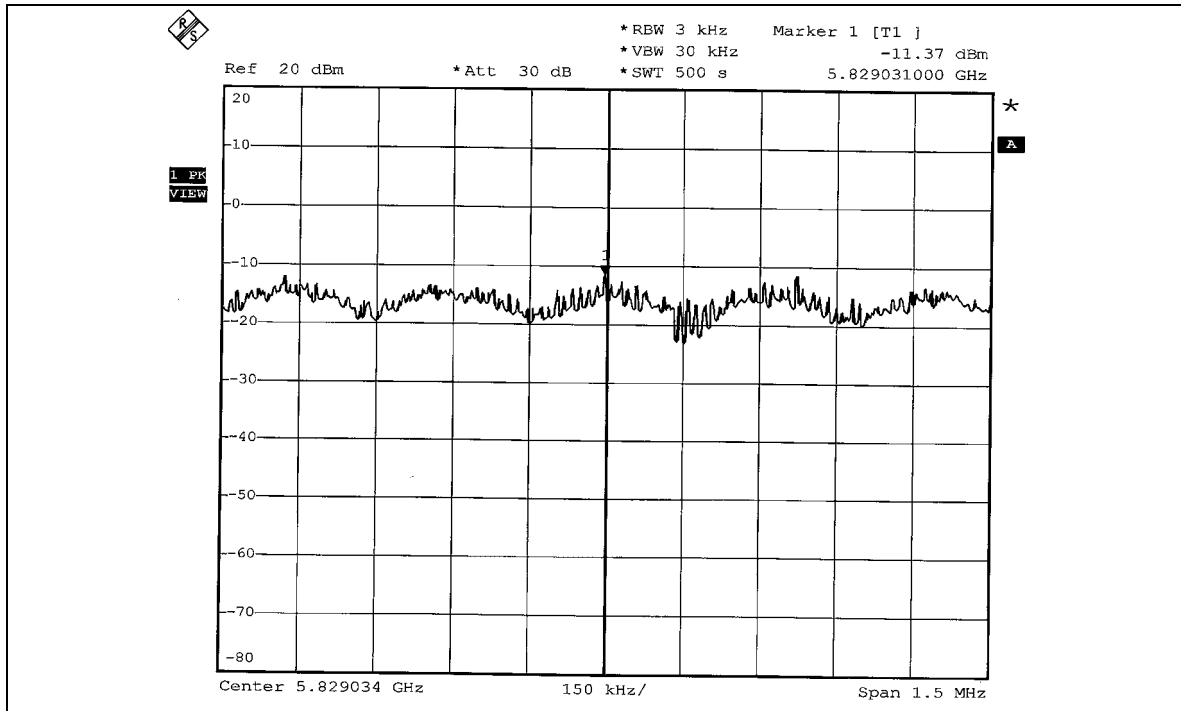



## 5.6 BAND EDGES MEASUREMENT

### 5.6.1 LIMITS OF BAND EDGES MEASUREMENT

Below -20dB of the highest emission level of operating band (in 100kHz Resolution Bandwidth).

### 5.6.2 TEST INSTRUMENTS

Description & Manufacturer	Model No.	Serial No.	Calibrated Until
R&S SPECTRUM ANALYZER	FSEK30	100049	Aug. 12, 2005

**NOTES:**

The calibration interval of the above test instruments is 12 months and the calibrations are traceable to NML/ROC and NIST/USA.

### 5.6.3 TEST PROCEDURE

The transmitter output was connected to the spectrum analyzer via a low lose cable. Set both RBW and VBW of spectrum analyzer to 100 kHz with suitable frequency span including 100 MHz bandwidth from band edge. The band edges was measured and recorded.

### 5.6.4 DEVIATION FROM TEST STANDARD

No deviation



### 5.6.5 EUT OPERATING CONDITION

Same as Item 5.9.6

### 5.6.6 TEST RESULTS

The spectrum plots are attached on the following pages. D2 line indicates the highest level, D1 line indicates the 20dB offset below D2. It shows compliance with the requirement in part 15.247(d).





802.11a OFDM modulation

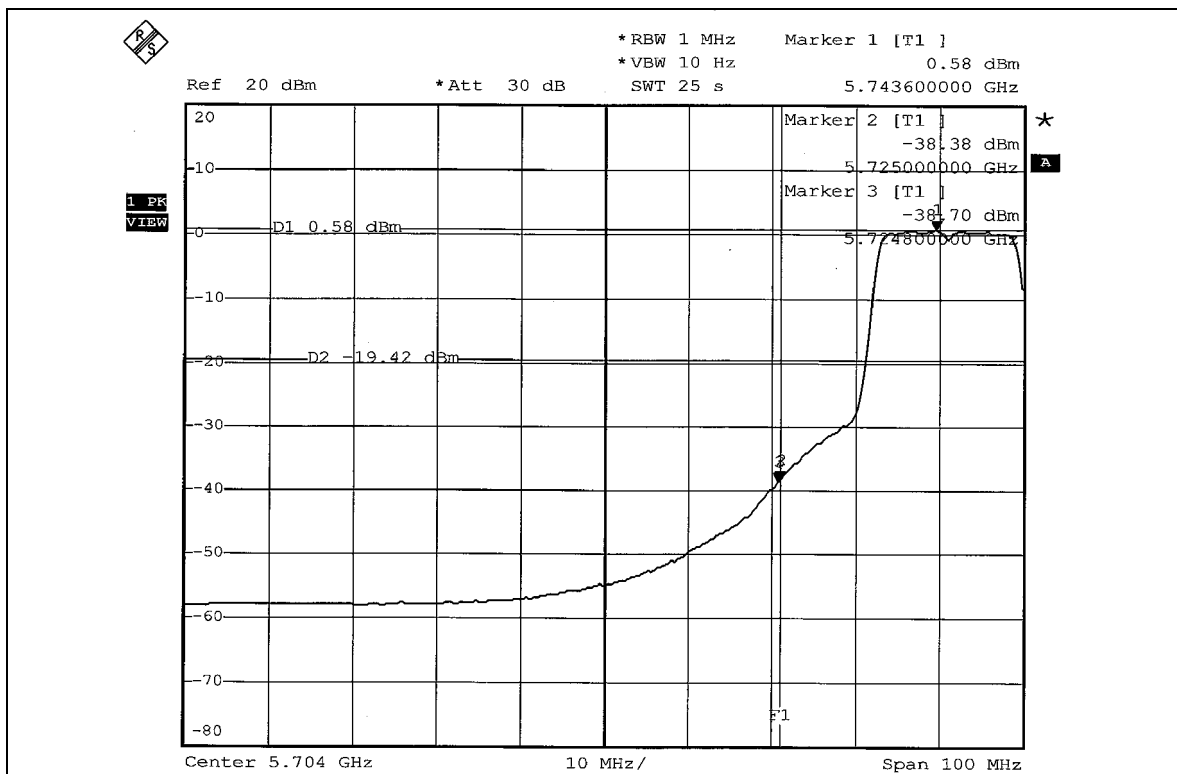
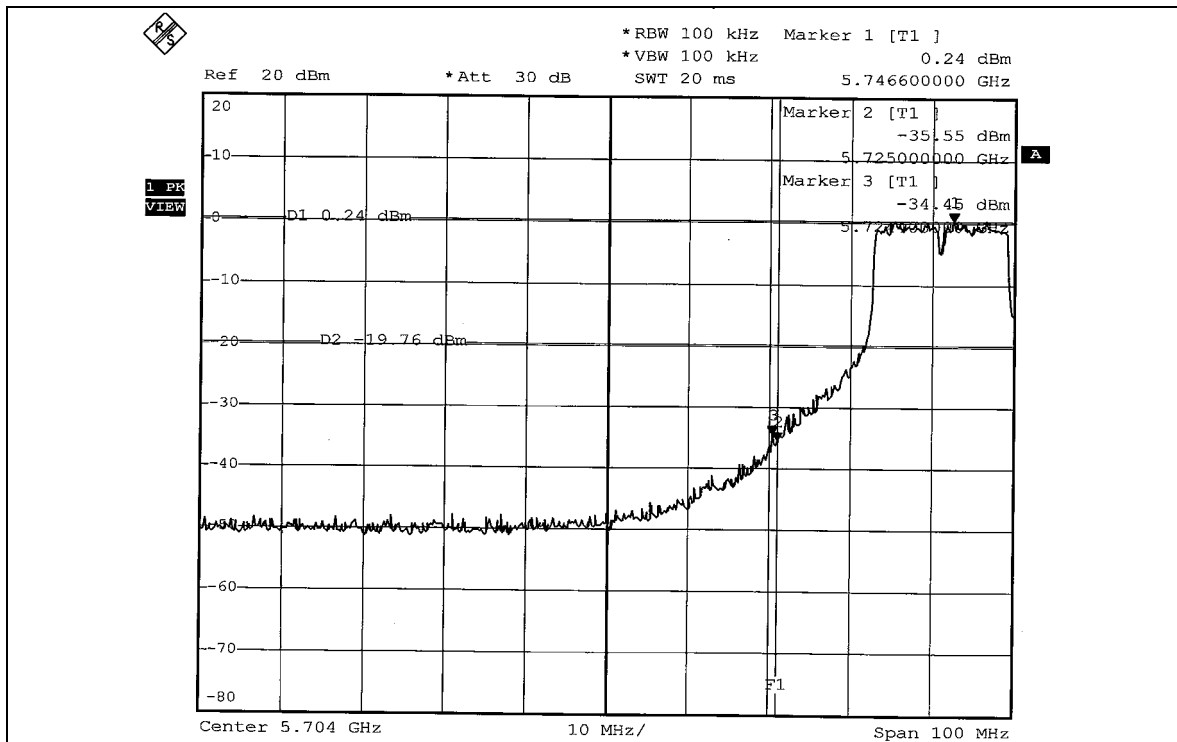

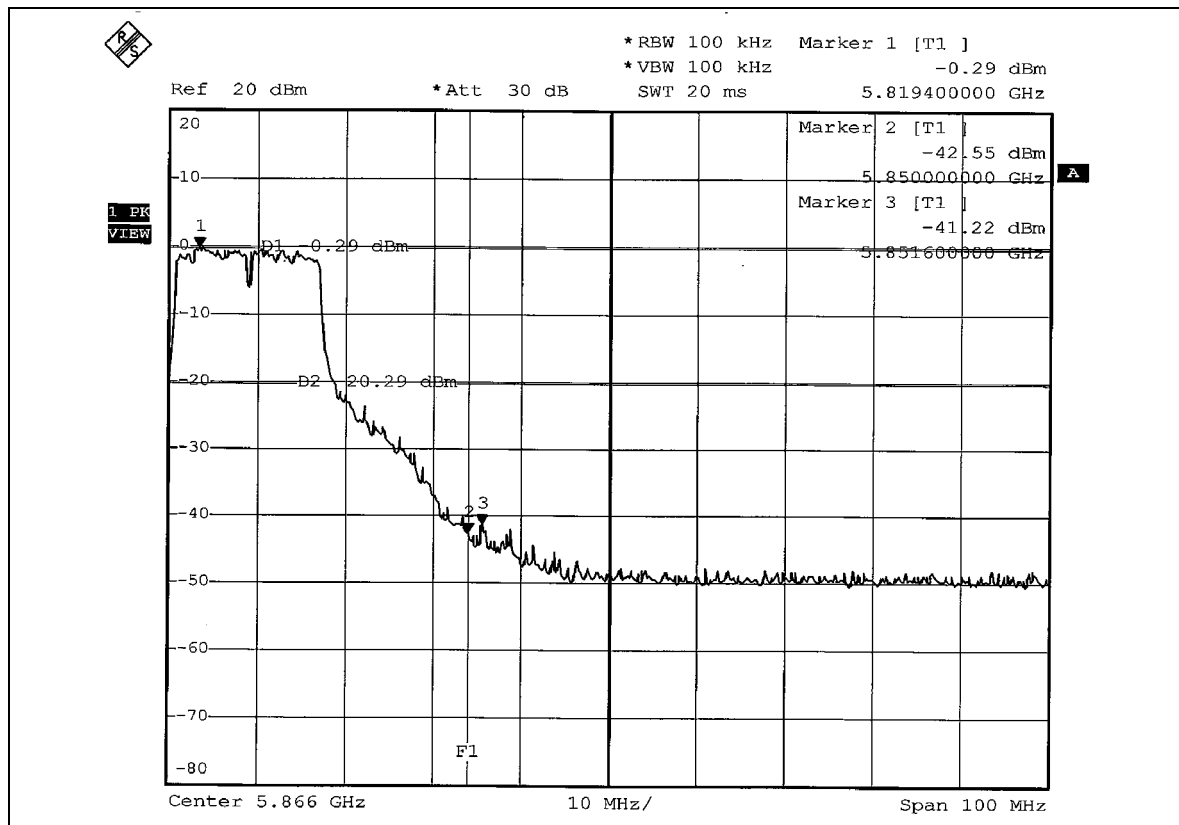
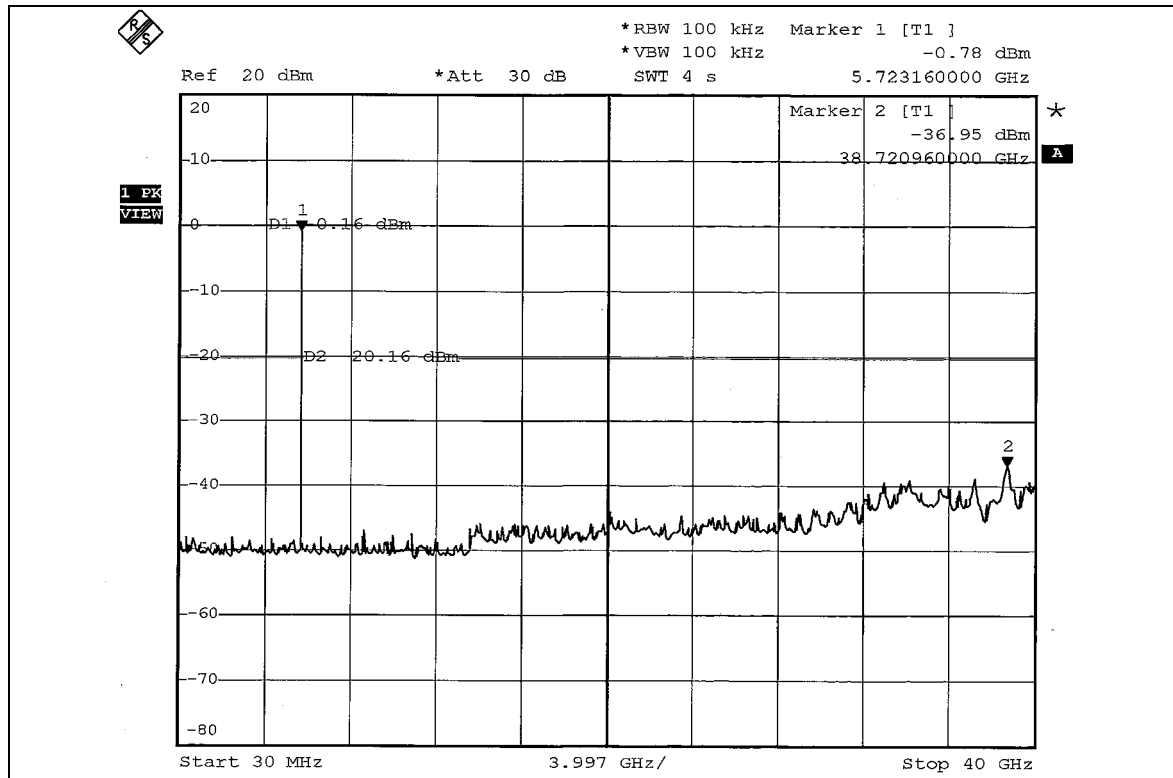

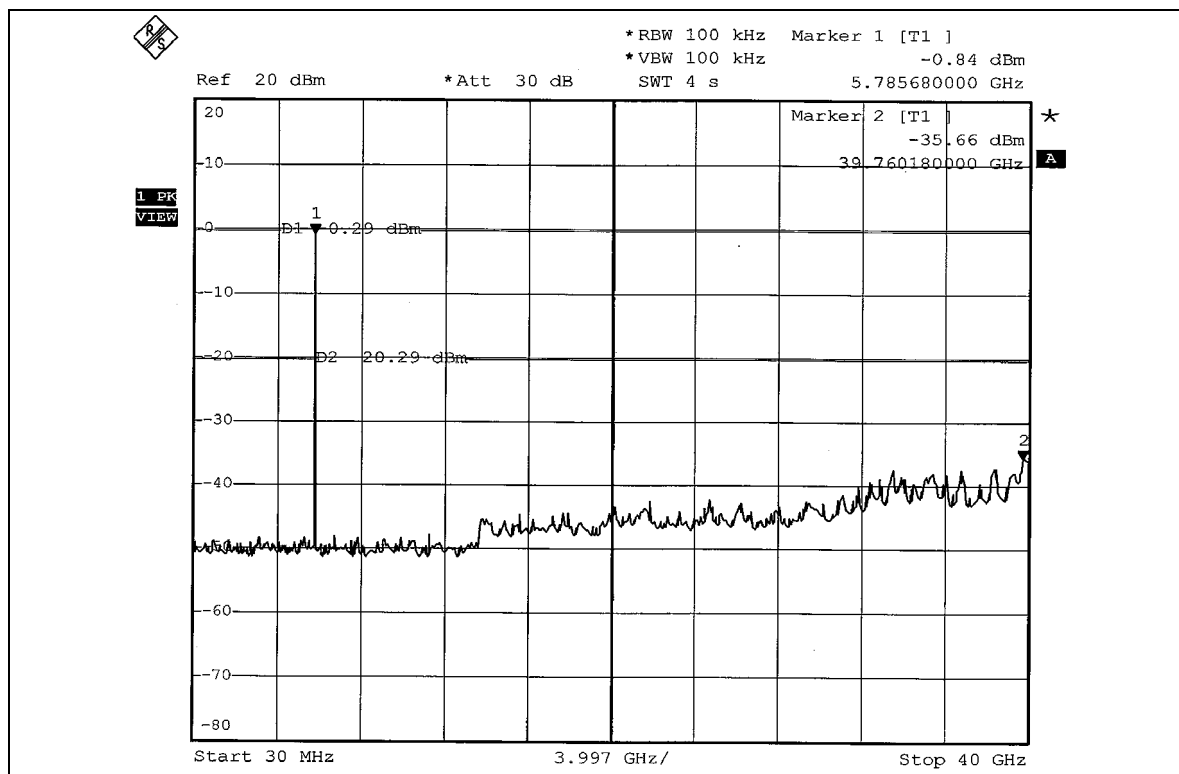
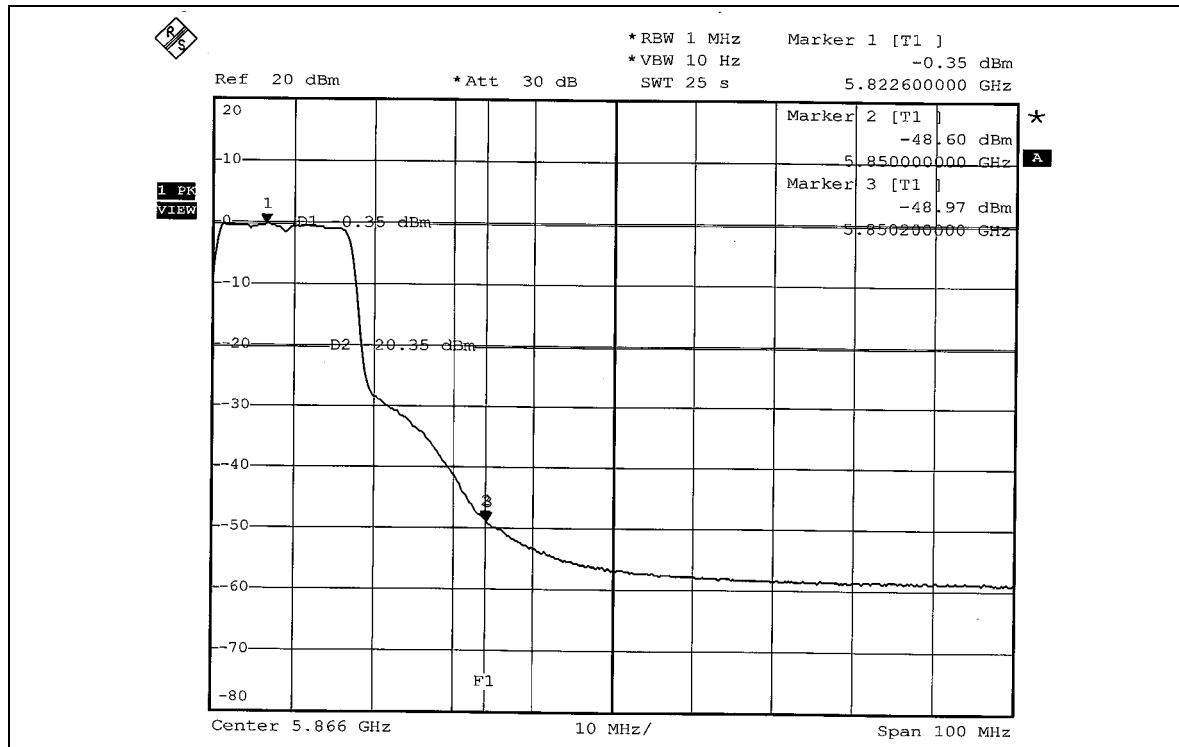



## **5.7 ANTENNA REQUIREMENT**

### **5.7.1 STANDARD APPLICABLE**

For intentional device, according to FCC 47 CFR Section 15.203, an intentional radiator shall be designed to ensure that no antenna other than that furnished by the responsible party shall be used with the device.

And according to FCC 47 CFR Section 15.247(a), if transmitting antennas of directional gain greater than 6dBi are used, the power shall be reduced by the amount in dB that the directional gain of the antenna exceeds 6dBi.

### **5.7.2 ANTENNA CONNECTED CONSTRUCTION**

The antenna used in this product is Dipole antenna with Reverse-TNC connector. The maximum Gain of the antenna is 2dBi.

## 6. PHOTOGRAPHS OF THE TEST CONFIGURATION

### CONDUCTED EMISSION TEST

#### Test Mode 1



Test Mode 2



Test Mode 3



### RADIATED EMISSION TEST

#### Test Mode 1

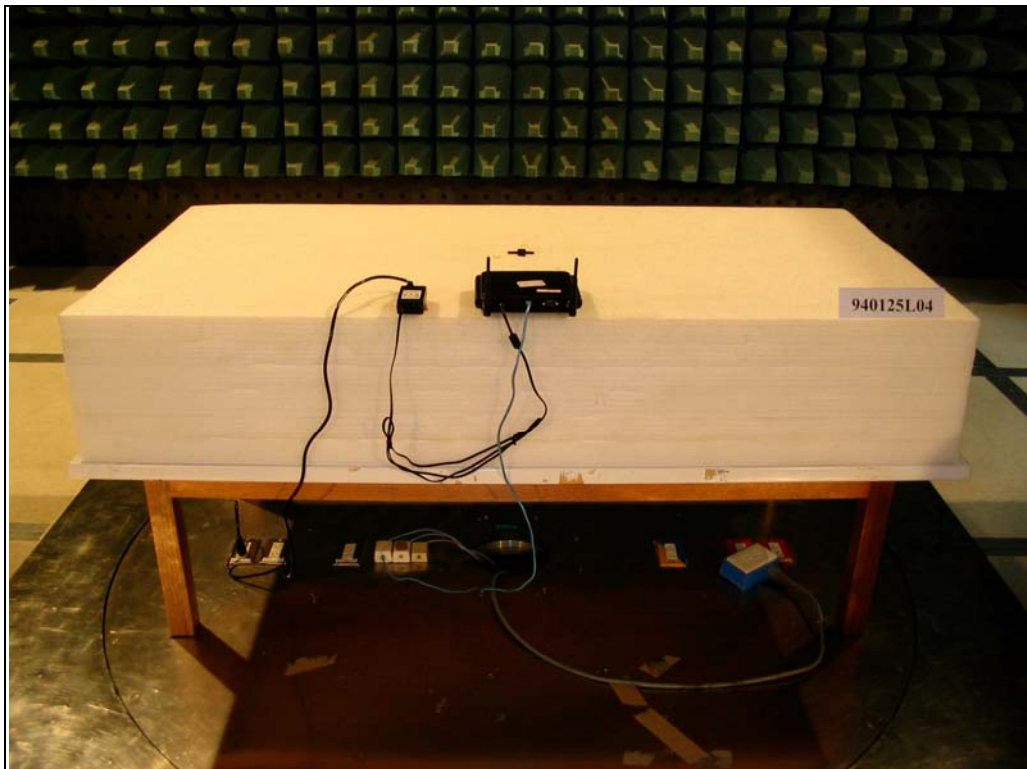
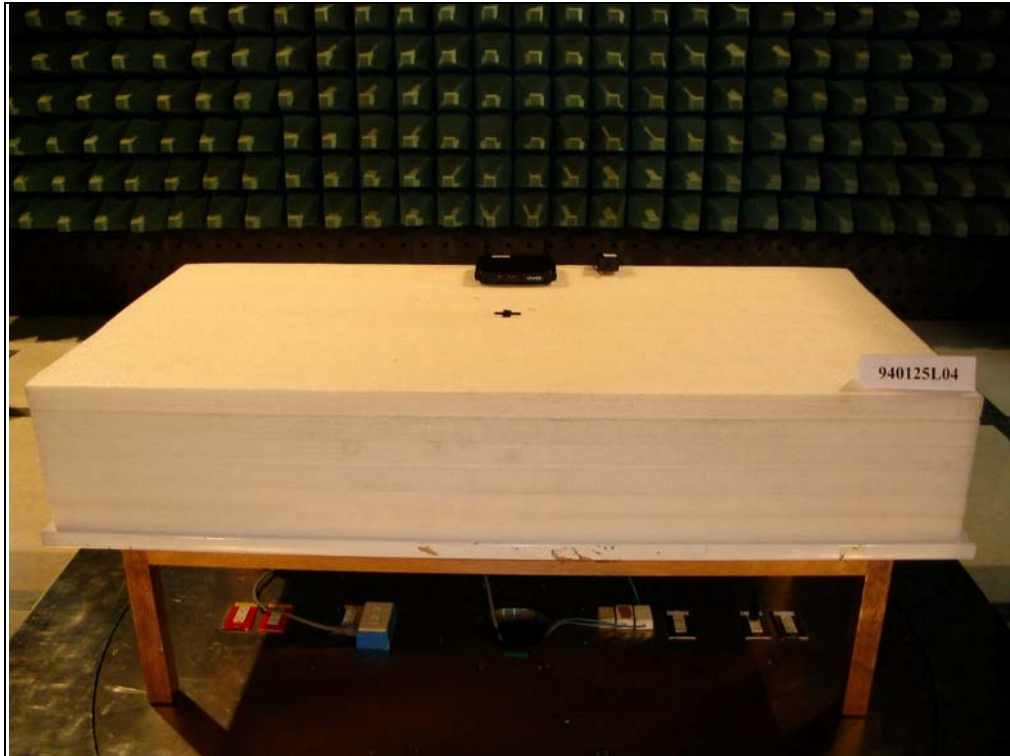



Test Mode 2

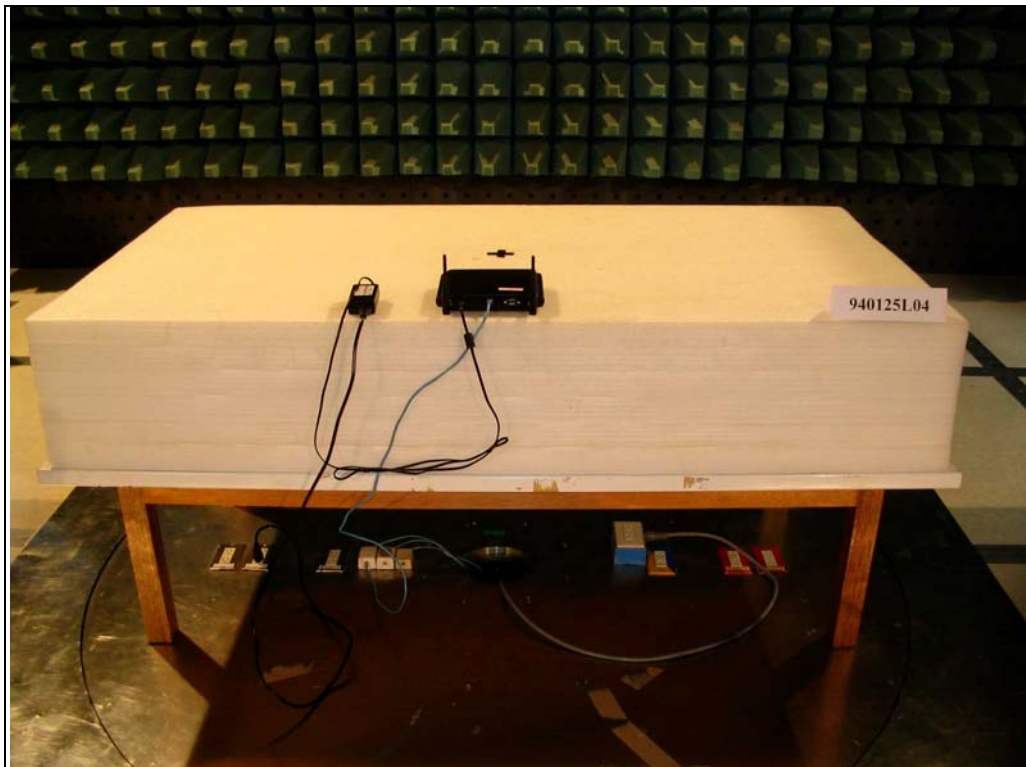
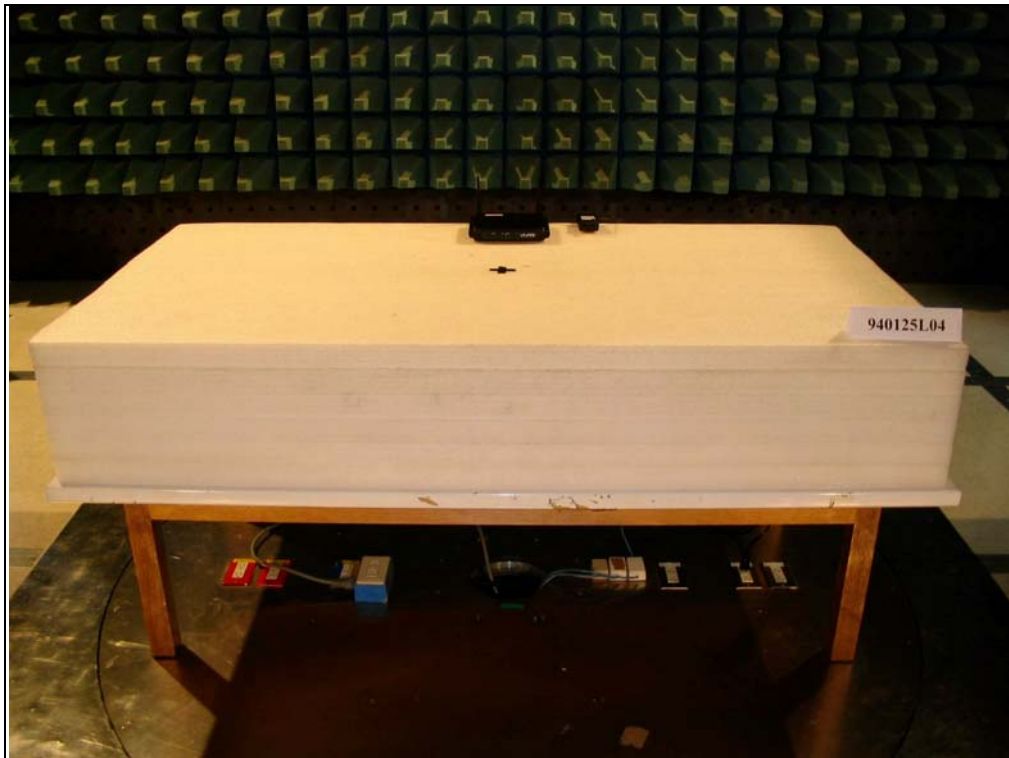

Test Mode 3

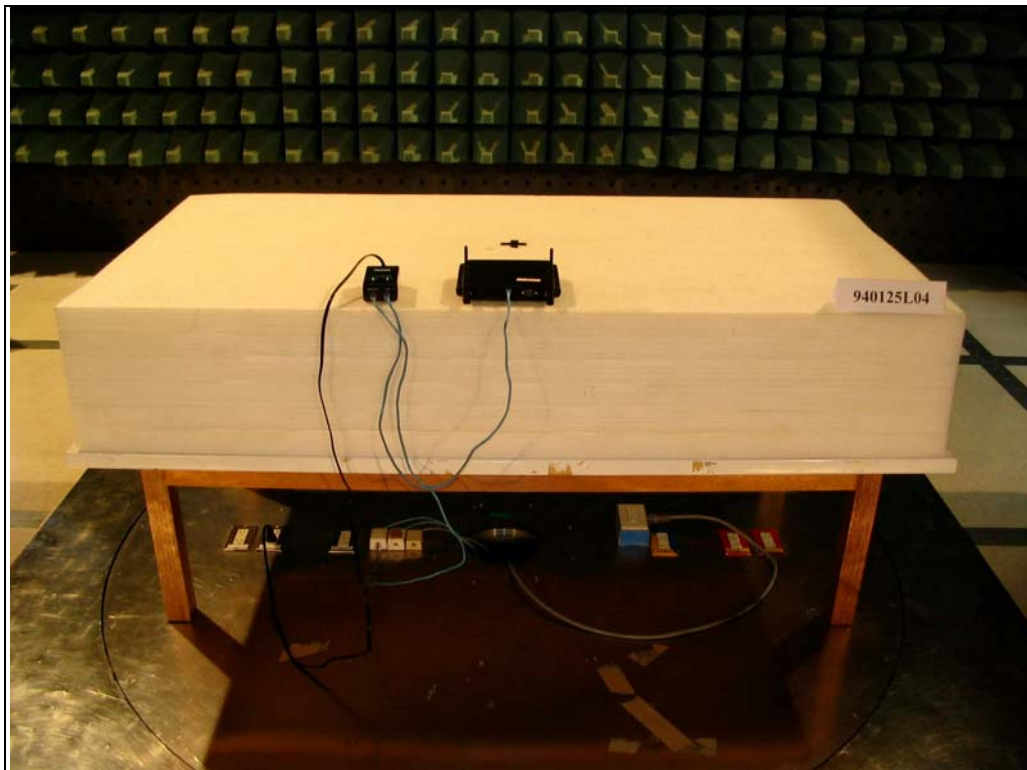
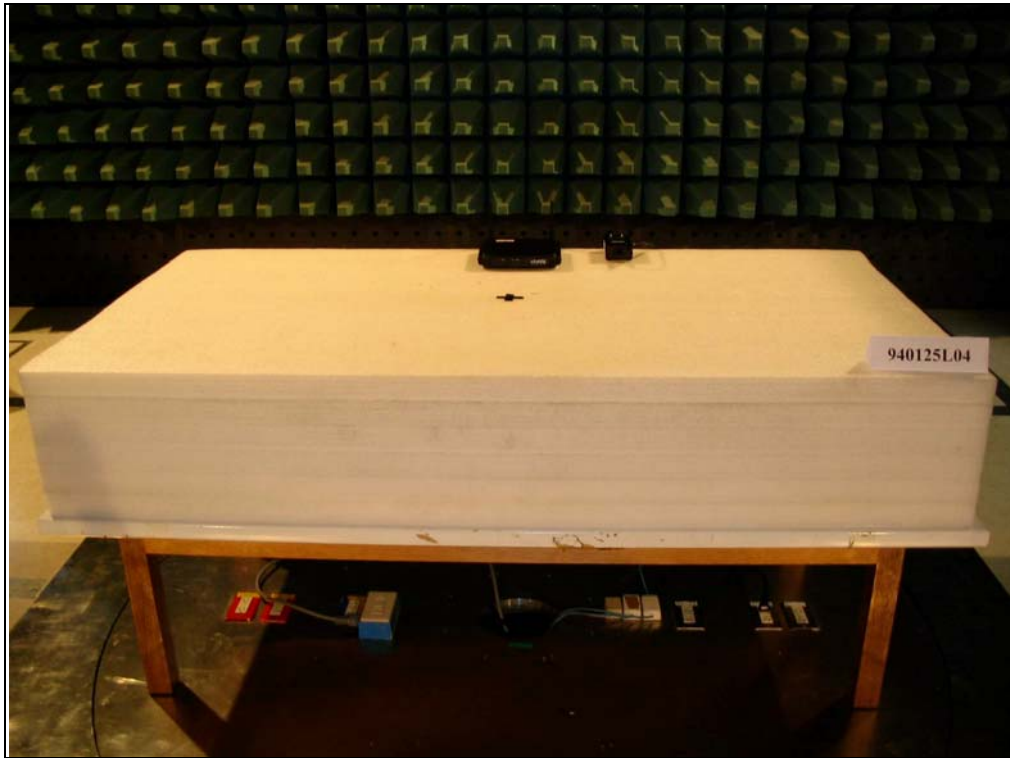



## 7. INFORMATION ON THE TESTING LABORATORIES

We, ADT Corp., were founded in 1988 to provide our best service in EMC, Radio, Telecom and Safety consultation. Our laboratories are accredited and approved by the following approval agencies according to ISO/IEC 17025.

<b>USA</b>	FCC, NVLAP, UL, A2LA
<b>Germany</b>	TUV Rheinland
<b>Japan</b>	VCCI
<b>Norway</b>	NEMKO
<b>Canada</b>	INDUSTRY CANADA , CSA
<b>R.O.C.</b>	CNLA, BSMI, DGT
<b>Netherlands</b>	Telefication
<b>Singapore</b>	PSB , GOST-ASIA(MOU)
<b>Russia</b>	CERTIS(MOU)

Copies of accreditation certificates of our laboratories obtained from approval agencies can be downloaded from our web site:

[www.adt.com.tw/index.5/phtml](http://www.adt.com.tw/index.5/phtml). If you have any comments, please feel free to contact us at the following:

**Linko EMC/RF Lab:**

Tel: 886-2-26052180

Fax: 886-2-26052943

**Hsin Chu EMC/RF Lab:**

Tel: 886-3-5935343

Fax: 886-3-5935342

**Hwa Ya EMC/RF/Safety Telecom Lab:**

Tel: 886-3-3183232

Fax: 886-3-3185050

**Linko RF Lab.**

Tel: 886-3-3270910

Fax: 886-3-3270892

**Web Site:** [www.adt.com.tw](http://www.adt.com.tw)

The address and road map of all our labs can be found in our web site also