



ATEN Technology, Inc., dba IOGEAR.
 Add: 15365 Barranca Pkwy Irvine, CA 92618, USA
 Contact: Joseph Zhang
 E-mail: jzhang@iogear.com
 Tel: 949-453-8782
 Fax: 949-453-8785

Product Specification

IEEE 802.11 a/n/ac 1T/1R USB Module

Project Name	WIFI Module
Model NO	G8811A 5G 11AC dual-band, 1T1R, WIFI module
Customer	
Customer's Part NO	

Draft: Jaylah	Check: JoJo	Approved: Bonnie
---------------	-------------	------------------

Feedback of customer's Confirmation <p align="center">We accept the specification after Confirmed.</p>		
Customer	Customer signature	Approved Date

CONTENTS

0 REVISION HISTORY.....3

1 INTRODUCTIONS.....4

 1.1 OVERVIEW.....4

 1.2 FEATURES.....4

2 GENERAL SPECIFICATION.....5

 2.1 WIFI SPECIFICATION.....5

3 MECHANICAL SPECIFICATION.....7

 3.1 OUTLINE DRAWING.....7

 3.2 PIN DEFINITION.....8

 3.3 TYPICAL APPLICATION CIRCUIT.....9

4 ENVIRONMENTAL REQUIREMENTS.....9

 4.1 OPERATING & STORAGE CONDITIONS.....9

 4.2 RECOMMENDED REFLOW PROFILE.....9

 4.3 NOTICE.....10

5 PACKAGE.....11

 5.1 PACKAGE INFORMATION.....11

6 FCC NOTICE.....12

0. Revision History

Version NO	Date	Modifications	Draft
Rev0.1	Dec.19.2014	First Released	Neal Yu
Rev0.2	Mar.09.2015	Update the outline drawing and package information	Neal Yu
Rev0.3	Mar.21.2015	Update the output power of 5G	Neal Yu

1. Introduction

This document is to specify the product requirements for 802.11a/b/g/n/ac USB Module. This Card is based on Realtek RTL8811AU chipset that complied with IEEE 802.11b/g/n/ac Draft 3.0 compatible WLAN ,and it is also backward complied with IEEE 802.11a standard from 5.15~5.825GHz wideband and IEEE 802.11b/g standard from 2.4~2.5GHz. It can be used to provide up to 54Mbps for IEEE 802.11a ,150Mbps for IEEE 802.11n and 433.3Mbps for IEEE 802.11ac to connect your wireless LAN.

1.1 Overview

The general hardware for the module is shown in Figure 1.

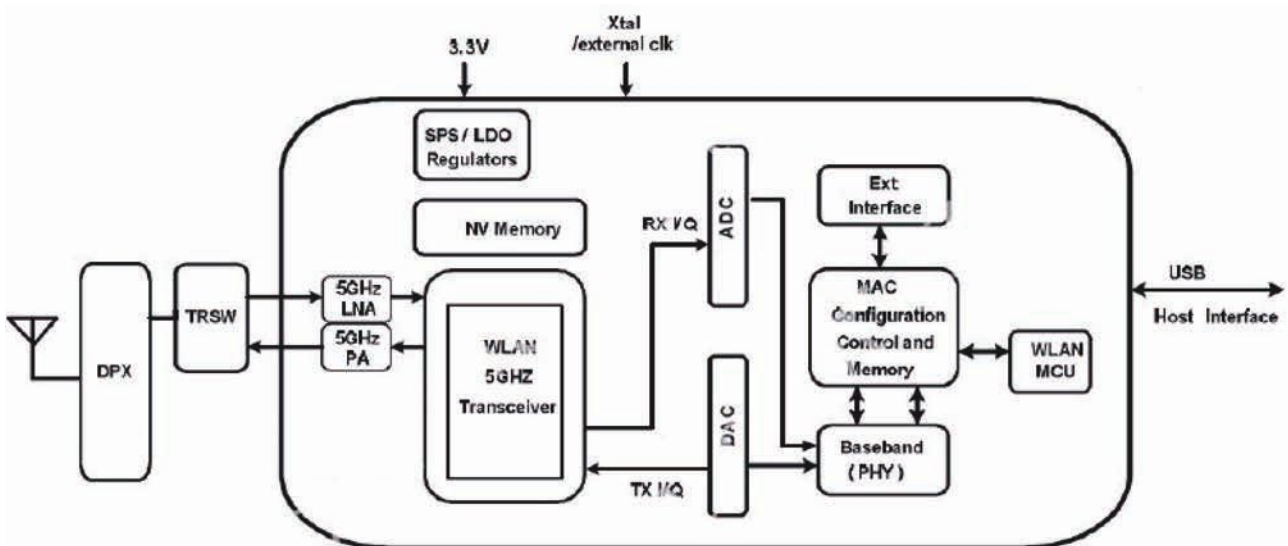

Figure 1. Dual-Band 11ac (1x1) Solution with single Antenna

1.2 Features

- Compatible with IEEE 802.11a standard to provide wireless 54Mbps data rate.
- Compatible with IEEE 802.11n standard to provide wireless 150Mbps data rate.
- Compatible with IEEE 802.11ac standard to provide wireless 433.3Mbps data rate.
- Operation at 5.15~5.825GHz frequency band to meet worldwide regulations
- Provides simple legacy and 20MHz/40MHz/80MHz co-existence mechanisms to ensure backward and network compatibility.
- Supports infrastructure networks via Access Point and ad-hoc network via peer-to-peer communication
- Supports IEEE 802.11i(WPA and WPA2),WAPI,. enhanced security

2. GENERAL SPECIFICATION

2.1 WiFi Specifications

Features	Descriptions	
Main Chipset	Realtek RTL8811AU	
Operating Frequency	5G: 5.150GHz~5.825GHz	
Host Interface	USB 2.0	
WIFI Standard	iIEEE802.11a/n/ac	
Modulation	802.11 n: BPSK , QPSK , 16QAM ,64QAM with OFDM 802.11a: QPSK , BPSK , 16QAM ,64QAM with OFDM 802.11ac: QPSK , BPSK , 16QAM ,64QAM,256QAM with OFDM	
PHY Data rates	802.11a: 6,9,12,18,24,36,48,54Mbps 802.11n: up to 150Mbps 802.11ac: up to 433.3Mbps	
Transmit Output Power	802.11g@54Mbps 15±1.5dBm 802.11n@65Mbps 14±1.5dBm (MCS 0_HT20) 14±1.5dBm (MCS 7_HT20) 14±1.5dBm (MCS 0_HT40) 14±1.5dBm (MCS 7_HT40) 802.11a@54Mbps 13±1.5dBm 802.11ac@MCS7 13±1.5dBm	
Receiver Sensitivity Bandwidth: 20MHz (Typical Sensitivity at each RF chain at Which Frame(1000-byte PDUs)Error Rate=10% and at room Temp.25 degreeC)	802.11n@10% PER ● -82dBm at MCS0 ● -79dBm at MCS1 ● -77dBm at MCS2 ● -74dBm at MCS3 ● -70dBm at MCS4 ● -66dBm at MCS5 ● -65dBm at MCS6	● -79dBm at MCS0 ● -76dBm at MCS1 ● -74dBm at MCS2 ● -71dBm at MCS3 ● -67dBm at MCS4 ● -63dBm at MCS5 ● -62dBm at MCS6 ● -61dBm at MCS7
	5GHz Band/HT20 ● -82dBm at MCS0 ● -79dBm at MCS1	5GHz Band/HT40 ● -79dBm at MCS0 ● -76dBm at MCS1

	<ul style="list-style-type: none"> ● -77dBm at MCS2 ● -74dBm at MCS3 ● -70dBm at MCS4 ● -66dBm at MCS5 ● -65dBm at MCS6 ● -64dBm at MCS7 	<ul style="list-style-type: none"> ● -74dBm at MCS2 ● -71dBm at MCS3 ● -67dBm at MCS4 ● -63dBm at MCS5 ● -62dBm at MCS6 ● -61dBm at MCS7
	<p>802.11a@10% PER</p> <p>6Mbps ≤-82±1dBm</p> <p>9Mbps ≤-81±1dBm</p> <p>12Mbps ≤-79±1dBm</p> <p>18Mbps ≤-77±1dBm</p> <p>24Mbps ≤-74±1dBm</p> <p>36Mbps ≤-70±1dBm</p> <p>48Mbps ≤-66±1dBm</p> <p>54Mbps ≤-65±1dBm</p>	
	<p>802.11ac@10% PER</p> <p>5GHz Band / HT20</p> <ul style="list-style-type: none"> ● -82dBm at MCS0 ● -79dBm at MCS1 ● -77dBm at MCS2 ● -74dBm at MCS3 ● -70dBm at MCS4 ● -66dBm at MCS5 ● -65dBm at MCS6 ● -64dBm at MCS7 ● -59dBm at MCS8 ● -57dBm at MCS9 	<p>5GHz Band / HT40</p> <ul style="list-style-type: none"> ● -79dBm at MCS0 ● -76dBm at MCS1 ● -74dBm at MCS2 ● -71dBm at MCS3 ● -67dBm at MCS4 ● -63dBm at MCS5 ● -62dBm at MCS6 ● -61dBm at MCS7 ● -56dBm at MCS8 ● -54dBm at MCS9
	<p>5GHz Band / HT80</p> <ul style="list-style-type: none"> ● -76dBm at MCS0 ● -73dBm at MCS1 ● -71dBm at MCS2 ● -68dBm at MCS3 ● -64dBm at MCS4 ● -60dBm at MCS5 ● -59dBm at MCS6 ● -58dBm at MCS7 ● -55dBm at MCS8 ● -51dBm at MCS9 	
Operation Range	Up to 150meters in open space	
RF Antenna	External Antenna	
Antenna Gain	5 dBi	
OS Support	Windows XP, Vista, Win7	
Security	WEP, TKIP, AES, WPA, WPA2	
Dimension	L23.0mm*W17.0mm*T3.0mm	
Power Consumption 3.3V Power supply	LINK	200mA
	TX 5G	20M:300mA; 40M:270mA; 80M:260mA
	RX	210mA

3. Mechanical Specification

3.1 Outline Drawing(unit: mm)



(Top Side)

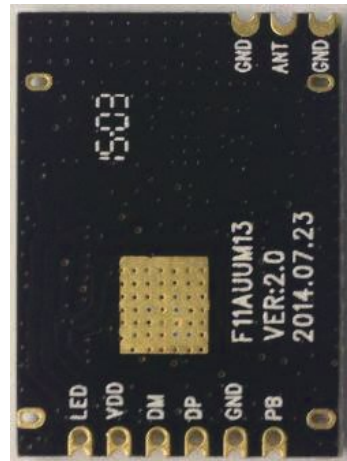

(Bottom Side)

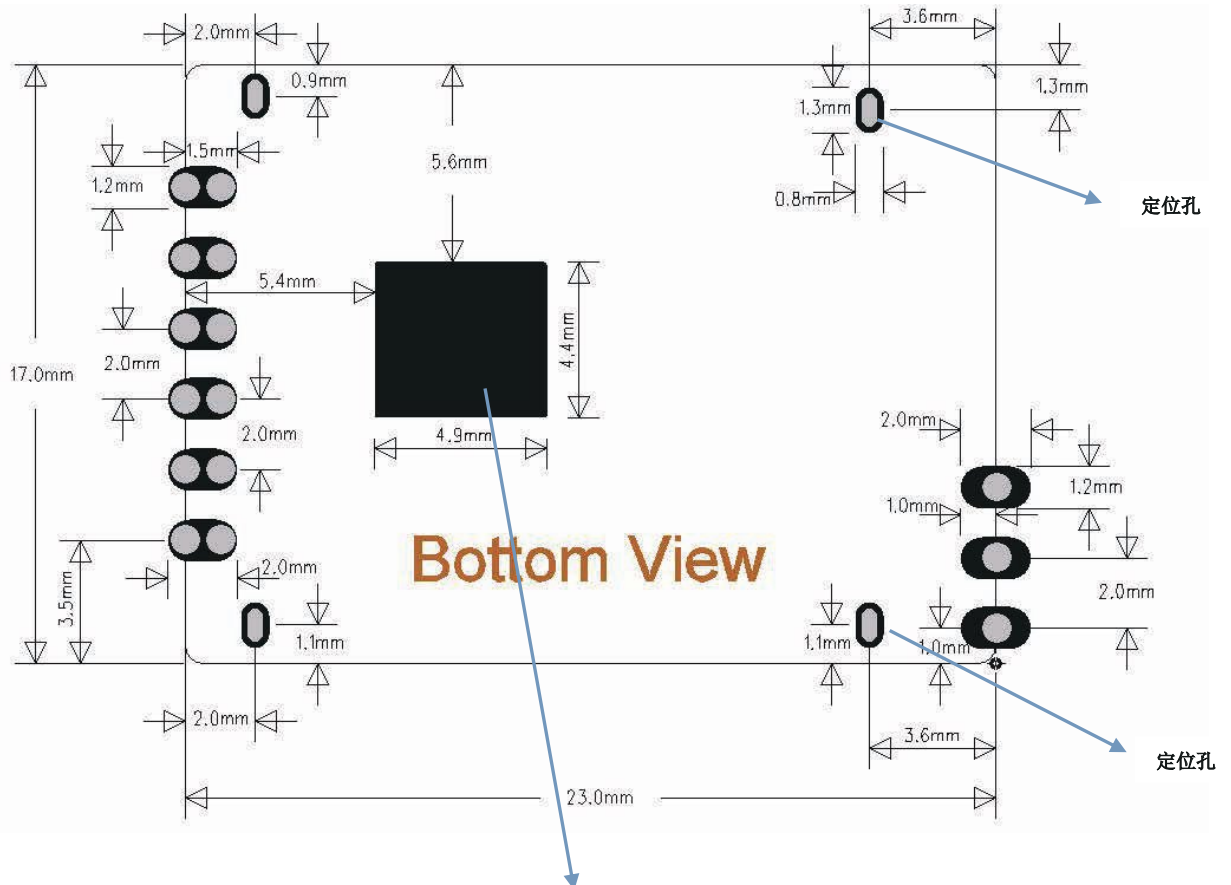

Bottom View

散热接地焊盘 (Bottom)

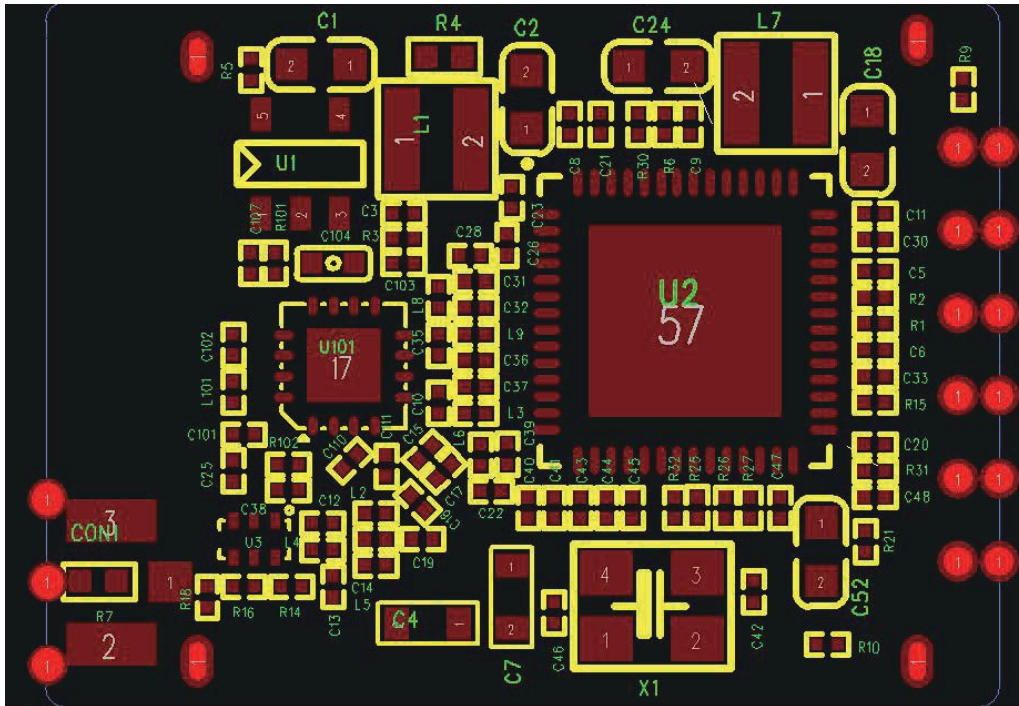

3.2 Connector Pin Definition

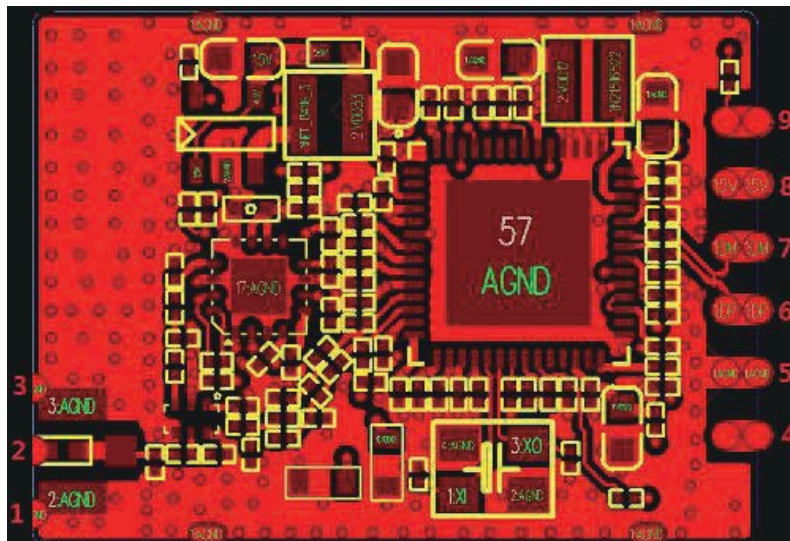

Pin #	Name	Description
1	GND	Ground
2	RF	Antenna
3	GND	Ground
4	PB	WPS
5	GND	Ground
6	DP	USB+
7	DM	USB-
8	VDD	3.3V Input
9	LED	LED PIN

3.3 Typical Application Circuit

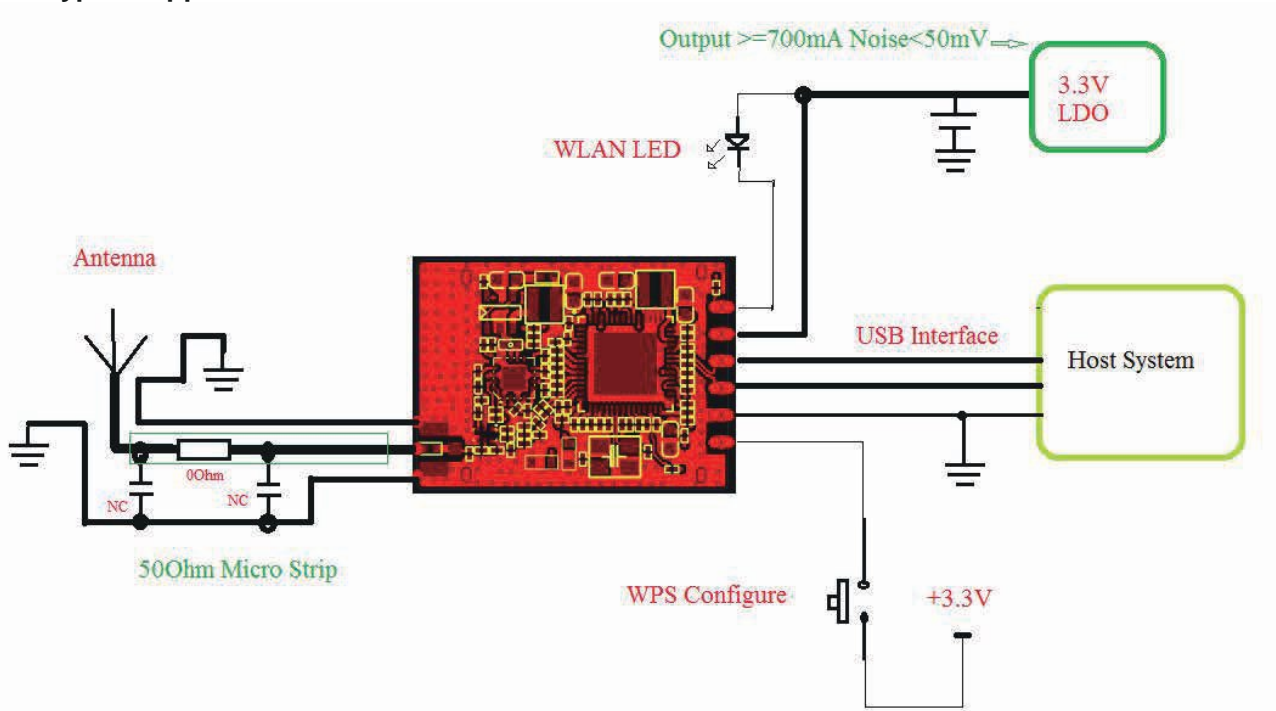

4. Environmental Requirements

4.1 Operating & Storage Conditions

Operating	Temperature: 0°C to +70°C
	Relative Humidity: 10-90% (non-condensing)
Storage	Temperature: -40°C to +80°C (non-operating)
	Relative Humidity: 5-90% (non-condensing)
MTBF (Mean Time Between Failures)	Over 150,000hours

4.2 Recommended Reflow Profile

Referred to IPC/JEDEC standard.

Peak Temperature : <250°C

Number of Times : ≤2 times

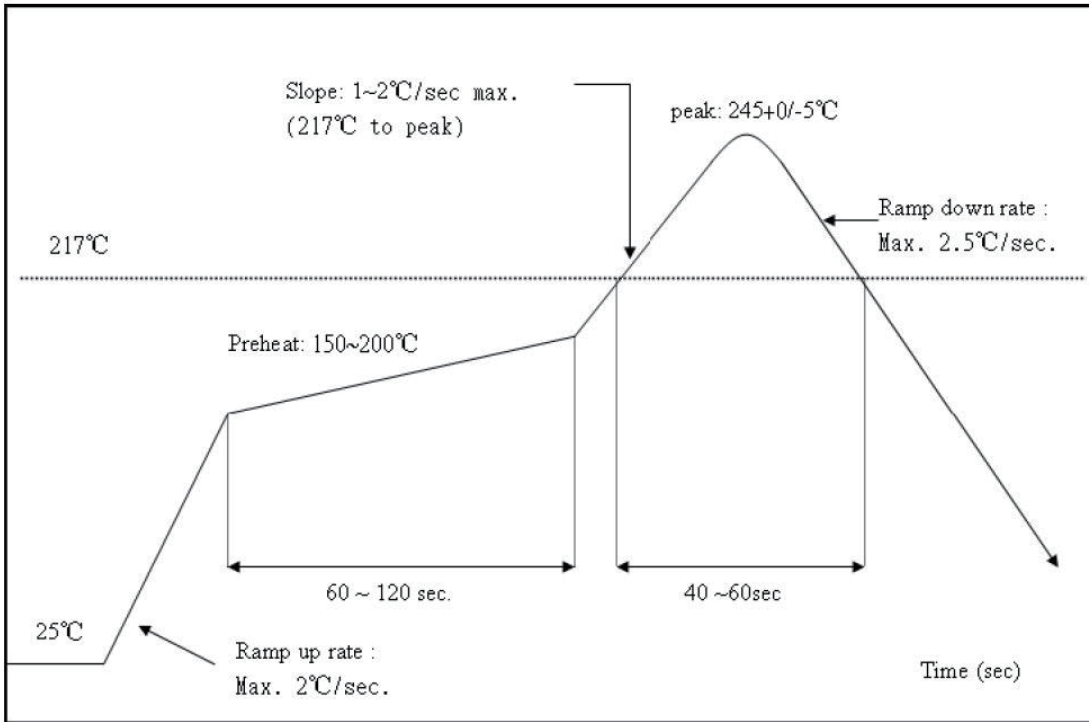

4.3 Patch WIFI modules installed before the notice:

WIFI module installed note:

1. Please press 1 : 1 and then expand outward proportion to 0.7 mm, 0.12 mm thickness When open a stencil
2. Take and use the WIFI module, please insure the electrostatic protective measures.
3. Reflow soldering temperature should be according to the customer the main size of the products, such as the temperature set at 250 + 5 °C for the MID motherboard.

About the module packaging, storage and use of matters needing attention are as follows:

1. The module of the reel and storage life of vacuum packing: 1). Shelf life: 8 months, storage environment conditions: temperature in: < 40 °C, relative humidity: < 90% r.h.
2. The module vacuum packing once opened, time limit of the assembly:
 - 1) check the humidity display value should be less than 30% (in blue), such as: 30% ~ 40% (pink), or greater than 40% (red) the module have been moisture absorption.
 - 2) factory environmental temperature humidity control: $\leq 30\% \text{ }^{\circ}\text{C}$, $\leq 60\% \text{ r.h.}$.
 - 3) Once opened, the workshop the preservation of life for 168 hours.
3. Once opened, such as when not used up within 168 hours:
 - 1) The module must be again to remove the module moisture absorption.
 - 2) The baking temperature: 125 °C, 8 hours.
 - 3) After baking, put the right amount of desiccant to seal packages.

5. Package

5.1 Package information

Tray size: L258.0*W205.0 mm

Carton size: L310.0*W260.0*H220.0 mm

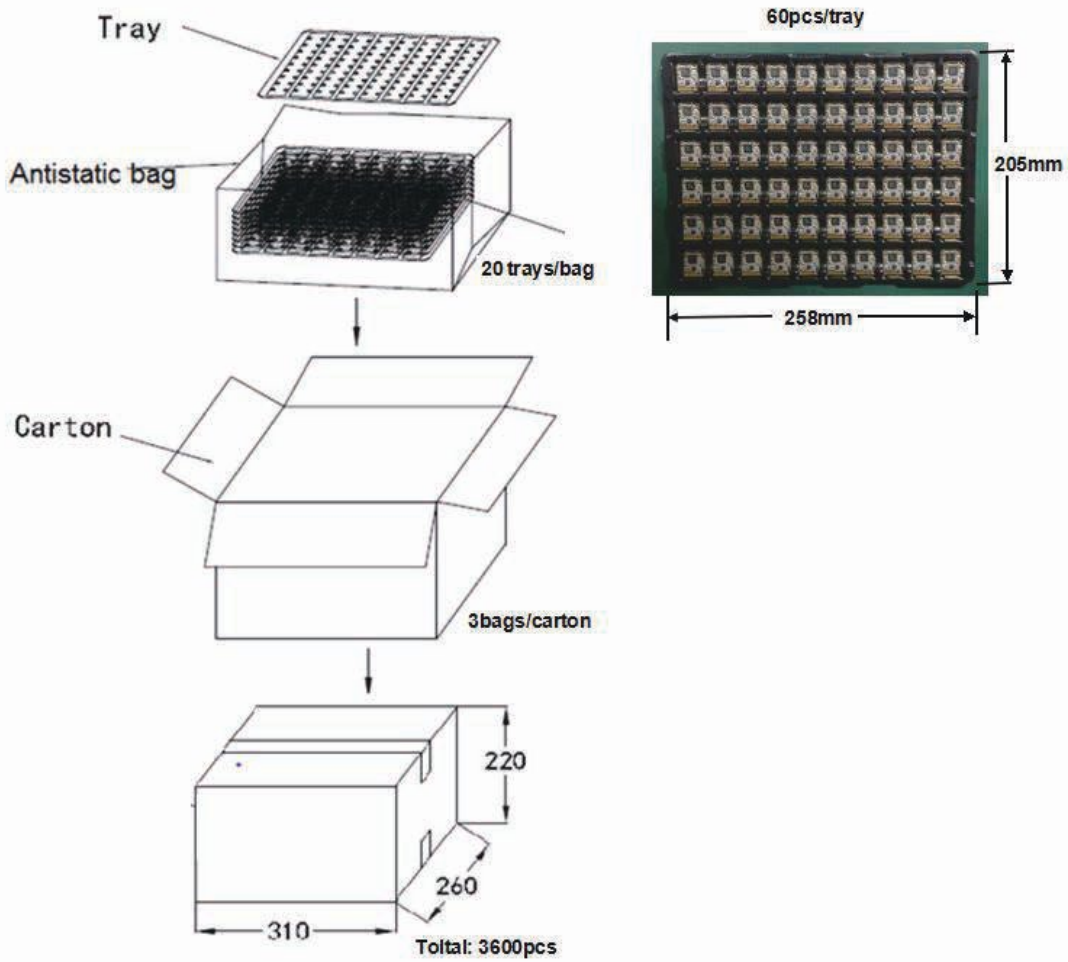

6. Notice

6.1 FCC notice

FCCID:QLEG8811A

Warning: Changes or modifications to this unit not expressly approved by the party responsible for compliance could void the user's authority to operate the equipment.

NOTE: This equipment has been tested and found to comply with the limits for a Class B digital device, pursuant to Part 15 of the FCC Rules. These limits are designed to provide reasonable protection against harmful interference in a residential installation. This equipment generates, uses and can radiate radio frequency energy and, if not installed and used in accordance with the instructions, may cause harmful interference to radio communications.

However, there is no guarantee that interference will not occur in a particular installation. If this equipment does cause harmful interference to radio or television reception, which can be determined by turning the equipment off and on, the user is encouraged to try to correct the interference by one or more of the following measures:

- Reorient or relocate the receiving antenna.
- Increase the separation between the equipment and receiver.
- Connect the equipment into an outlet on a circuit different from that to which the receiver is connected.
- Consult the dealer or an experienced radio/TV technician for help.
- "The device must not be co-located or operating in conjunction with any other antenna or transmitter."

FCC RF Radiation Exposure Statement Caution: To maintain compliance with the FCC's RF exposure guidelines, place the product at least 20cm from nearby persons. The Module can be installed in Mobile or fix device only, and it can not be installed in any portable Device.

FCC Conditions

This device complies with part 15 of the FCC Rules. Operation is subject to the following two conditions:

1. This device may not cause harmful interference.
2. This device must accept any interference received, including interference that may cause undesired operation.

This device complies with Part 15, Part 15.407 of the FCC Rules. The FCC ID for this device is:QLEG8811A

If the FCC ID is not visible with the module is installed inside another device, then it must be still responsible for the FCC compliance requirement of the end product which referring to the enclosed module and it also must display a label, such as the following:

Contains Transmitter module FCC ID: QLEG8811A or contains FCC ID:QLEG8811A

The host product manufacturer is responsible for compliance to any other FCC rules that apply to the host not covered by the modular transmitter grant of certification. The final host product still requires Part 15 Subpart B compliance testing with the modular transmitter installed.

The end user manual shall include all required regulatory information / warning as shown in this manual, include: This product must be installed and operated with a minimum distance of 20 cm between the radiator and user body.