

APPLICANT: MESH NETWORKS

FCC ID: QJEWMC63000902

TABLE OF CONTENTS

TEST REPORT CONTAINING:

PAGE	1.....	LETTER OF EXPLANATION
PAGE	2-4.....	LIST OF TEST EQUIPMENT
PAGE	5.....	TEST PROCEDURES
PAGE	6.....	PRODUCT DESCRIPTION
PAGE	7.....	POWERLINE CONDUCTED INTERFERENCE
PAGE	8-9.....	POWERLINE CONDUCTED PLOTS
PAGE	10.....	OCCUPIED BANDWIDTH AND POWER OUTPUT
PAGE	11.....	6 dB BANDWIDTH PLOT
PAGE	12.....	METHOD OF MEASURING RF CONDUCTED AND SPURIOUS EMISSIONS AT ANTENNA TERMINALS DATA
PAGE	13-14.....	RADIATION INTERFERENCE TEST DATA
PAGE	15.....	METHOD OF MEASURING RADIATED SPURIOUS EMISS.
PAGE	16.....	RADIATED SPURIOUS EMISSIONS INTO ADJACENT RESTRICTED BANDS
PAGE	17-20.....	BANDEDGE PLOTS
PAGE	21.....	POWER SPECTRAL DENSITY
PAGE	22.....	POWER SPECTRAL DENSITY PLOTS

EXHIBIT ATTACHMENTS:

EXHIBIT	1.....	REQUEST FOR CONFIDENTIALITY LETTER
EXHIBIT	2.....	FCC ID LABEL SAMPLE
EXHIBIT	3.....	SKETCH OF FCC ID LABEL LOCATION
EXHIBIT	4.....	EXTERNAL PHOTOGRAPHS
EXHIBIT	5.....	INTERNAL PHOTOGRAPHS
EXHIBIT	6.....	BLOCK DIAGRAM
EXHIBIT	7.....	SCHEMATICS
EXHIBIT	8.....	USERS MANUAL
EXHIBIT	9.....	OPERATIONAL DESCRIPTION
EXHIBIT	10.....	ANTENNA SPECIFICATIONS
EXHIBIT	11.....	RF EXPOSURE AND MPE CALCULATIONS
EXHIBIT	12.....	TEST SETUP PHOTOGRAPHS
EXHIBIT	13.....	DUTY CYCLE CORRECTION FACTOR

APPLICANT: MESH NETWORKS

FCC ID: QJEWMC63000901

REPORT #: M/MeshNetworks\863UT2\863UT2TestReport.doc

TABLE OF CONTENTS LIST

October 4, 2002

Federal Communications Commission
Authorization and Evaluation Division
7435 Oakland Mills Road
Columbia, MD 21046

SUBJECT: MESH NETWORKS' FCC ID QJEWMC63000902

FCC ID:

To Whom It May Concern:

The attached application is for a direct sequence spread spectrum assembly, made up of a PCMCIA card and antennas as specified in this report. Mesh Networks purchases standard antennas from the manufacturer. This device is different than most 802.11 devices in that its network protocol uses quad division multiple access. QDMA is a DSSS technology, operating in the 2400 to 2483.5 MHz ISM band, that utilizes a CSMA/CA (carrier sensed multiple access /collision avoidance) protocol, but the channelization is different from 802.11. QDMA has 4 concurrently available 20MHz channels - one of which is dedicated as a reservation and overhead channel, the other 3 for data transport.

Under normal operation a terminal will use the reservation channel (default channel 0 (2410 MHz)) for command and control information, and data channels (default 1(2430 MHz), 2 (2450 MHz)and 3(2470)) for transferring information.

Thus under normal operation the terminal will use the reservation channel (0)(2410 MHz) to request the ability to send network update information on a data channel (1,2 or 3). When the overall system traffic is low the terminal will default to using channel 3 for data transfer to provide the greatest separation of active channels, which reduces interference. As the system becomes more loaded terminals will choose channels 1, 2 or 3 depending on the RF transmissions in its vicinity. This will have the effect of making the use of the channels appear random as the timing of transmission by all terminals, and therefore choice of channel is random.

Should you have any questions or require any further information with regards to this, please feel free to contact me.

Sincerely,

Mario R. de Aranzeta C.E.T.

MRD/sh
Encl.

EMC Equipment List

	DEVICE	MFGR	MODEL	SERNO	CAL/CHAR DATE	DUE DATE or STATUS
X	3-Meter OATS	TEI	N/A	N/A	Listed 12/22/99	12/22/02
	3/10-Meter OATS	TEI	N/A	N/A	Listed 3/26/01	3/26/04
	Receiver, Beige Tower Spectrum Analyzer (Tan)	HP	8566B Opt 462	3138A07786 3144A20661	CAL 8/31/01	8/31/03
	RF Preselector (Tan)	HP	85685A	3221A01400	CAL 8/31/01	8/31/03
	Quasi-Peak Adapter (Tan)	HP	85650A	3303A01690	CAL 8/31/01	8/31/03
X	Receiver, Blue Tower Spectrum Analyzer (Blue)	HP	8568B	2928A04729 2848A18049	CHAR 10/22/01	10/22/03
X	RF Preselector (Blue)	HP	85685A	2926A00983	CHAR 10/22/01	10/22/03
X	Quasi-Peak Adapter (Blue)	HP	85650A	2811A01279	CHAR 10/22/01	10/22/03
X	Biconnical Antenna	Electro-Metrics	BIA-25	1171	CAL 4/26/01	4/26/03
	Biconnical Antenna	Eaton	94455-1	1096	CAL 10/1/01	10/1/03
	Biconnical Antenna	Eaton	94455-1	1057	CHAR 3/15/00	3/15/02
	BiconiLog Antenna	EMCO	3143	9409-1043		
X	Log-Periodic Antenna	Electro-Metrics	LPA-25	1122	CAL 10/2/01	10/2/03
	Log-Periodic Antenna	Electro-Metrics	EM-6950	632	CHAR 10/15/01	10/15/03
	Log-Periodic Antenna	Electro-Metrics	LPA-30	409	CHAR 10/16/01	10/16/03
	Dipole Antenna Kit	Electro-Metrics	TDA-30/1-4	152	CAL 3/21/01	3/21/04
	Dipole Antenna Kit	Electro-Metrics	TDA-30/1-4	153	CHAR 11/24/00	11/24/03
X	Double-Ridged Horn Antenna	Electro-Metrics	RGA -180	2319	CAL 12/19/01	12/19/03
	Horn Antenna	Electro-Metrics	EM-6961	6246	CAL 3/21/01	3/21/03
	Horn Antenna	ATM	19-443-6R	None	No Cal Required	
	Passive Loop Antenna	EMC Test Systems	EMCO 6512	9706-1211	CHAR 7/10/01	7/10/03
	Line Impedance Stabilization . . .	Electro-Metrics	ANS-25/2	2604	CAL 10/9/01	10/9/03

APPLICANT: MESH NETWORKS

FCC ID: QJEWMC63000902

REPORT #: M/MeshNetworks\863UT2\863UT2TestReport.doc

	DEVICE	MFGR	MODEL	SERNO	CAL/CHAR DATE	DUE DATE or STATUS
	Line Impedance Stabilization . . .	Electro-Metrics	EM-7820	2682	CAL 3/16/01	3/16/03
	Termaline Wattmeter	Bird Electronic Corporation	611	16405	CAL 5/25/99	5/25/01
	Termaline Wattmeter	Bird Electronic Corporation	6104	1926	CAL 12/12/01	12/12/03
	Oscilloscope	Tektronix	2230	300572	CHAR 2/1/01	2/1/03
	Temperature Chamber	Tenney Engineering	TTRC	11717-7	CHAR 1/22/02	1/22/04
	AC Voltmeter	HP	400FL	2213A14499	CAL 10/9/01	10/9/03
	AC Voltmeter	HP	400FL	2213A14261	CHAR 10/15/01	10/15/03
	AC Voltmeter	HP	400FL	2213A14728	CHAR 10/15/01	10/15/03
X	Digital Multimeter	Fluke	77	35053830	CHAR 1/8/02	1/8/04
	Digital Multimeter	Fluke	77	43850817	CHAR 1/8/02	1/8/04
	Digital Multimeter	HP	E2377A	2927J05849	CHAR 1/8/02	1/8/04
	Multimeter	Fluke	FLUKE-77-3	79510405	CAL 9/26/01	9/26/03
	Peak Power Meter	HP	8900C	2131A00545	CHAR 1/26/01	1/26/03
	Digital Thermometer	Fluke	2166A	42032	CAL 1/16/02	1/16/04
	Thermometer	Traulsen	SK-128		CHAR 1/22/02	1/22/04
X	Temp/Humidity gauge	EXTech	44577F	E000901	CHAR 1/22/02	1/22/04
	Frequency Counter	HP	5352B	2632A00165	CAL 11/28/01	11/28/03
	Power Sensor	Agilent Technologies	84811A	2551A02705	CAL 1/26/01	1/26/03
	Service Monitor	IFR	FM/AM 500A	5182	CAL 11/22/00	11/22/02
	Comm. Serv. Monitor	IFR	FM/AM 1200S	6593	CAL 5/12/02	5/12/04
	Signal Generator	HP	8640B	2308A21464	CAL 11/15/01	11/15/03
	Modulation Analyzer	HP	8901A	3435A06868	CAL 9/5/01	9/5/03
	Near Field Probe	HP	HP11940A	2650A02748	CHAR 2/1/01	2/1/03
	BandReject Filter	Lorch Microwave	5BR4-2400/ 60-N	Z1	CHAR 3/2/01	3/2/03

APPLICANT: MESH NETWORKS

FCC ID: QJEWMC63000902

REPORT #: M/MeshNetworks\863UT2\863UT2TestReport.doc

	DEVICE	MFGR	MODEL	SERNO	CAL/CHAR DATE	DUE DATE or STATUS
	BandReject Filter	Lorch Microwave	6BR6-2442/300-N	Z1	CHAR 3/2/01	3/2/03
	BandReject Filter	Lorch Microwave	5BR4-10525/900-S	Z1	CHAR 3/2/01	3/2/03
	High Pas Filter	Microlab	HA-10N		CHAR 10/4/01	10/4/03
	Audio Oscillator	HP	653A	832-00260	CHAR 3/1/01	3/1/03
	Frequency Counter	HP	5382A	1620A03535	CHAR 3/2/01	3/2/03
	Frequency Counter	HP	5385A	3242A07460	CHAR 12/11/01	12/11/03
	Preamplifier	HP	8449B-H02	3008A00372	CHAR 3/4/01	3/4/03
	Amplifier	HP	11975A	2738A01969	CHAR 3/1/01	3/1/03
	Egg Timer	Unk			CHAR 8/31/01	8/31/03
	Measuring Tape, 20M	Kraftixx	0631-20		CHAR 2/1/02	2/1/04
	Measuring Tape, 7.5M	Kraftixx	7.5M PROF1		2/1/02	2/1/04
	Coaxial Cable #51	Insulated Wire Inc.	NPS 2251-2880	Timco #51	CHAR 1/23/02	1/23/04
	Coaxial Cable #64	Semflex Inc.	60637	Timco #64	CHAR 1/24/02	1/24/04
	Coaxial Cable #65	General Cable Co.	E9917 RG233/U	Timco #65	CHAR 1/23/02	1/23/04
	Coaxial Cable #106	Unknown	Unknown	Timco #106	CHAR 1/23/02	1/23/04

TEST PROCEDURES USED

GENERAL: This report shall NOT be reproduced except in full without the written approval of TIMCO ENGINEERING, INC.

A test program was run which simulated a normal data transmission on a network.

R&O FCC 97-114 Appendix C: Guidance on Measurements for Direct Sequence Spread Spectrum Systems:

POWER LINE CONDUCTED INTERFERENCE: ANSI STANDARD C63.4-1992
Using a 50uH LISN. Both lines were observed with the UUT transmitting. The bandwidth of the spectrum analyzer was 10 kHz with an appropriate sweep speed. The ambient temperature of the UUT was 78°F with a humidity of 55%.

BANDWIDTH 6.0 dB: The measurements were made with the spectrum analyzer's resolution bandwidth (RBW)=100 kHz and the video bandwidth (VBW)=100 kHz and the span set as shown on plot.

POWER OUTPUT: The RF power output was measured at the antenna feed point using a peak power meter.

ANTENNA CONDUCTED EMISSIONS: The RBW=100 kHz, VBW=300 kHz and the span set to 10 MHz and the spectrum was scanned from 30 MHz to 10th harmonic.

RADIATION INTERFERENCE: The test procedure used was ANSI STANDARD C63.4-1992 using an Agilent spectrum receiver with a preselector. The bandwidth(RBW) of the spectrum analyzer was 100 kHz up to 1 GHz and 1 MHz above 1 GHz with an appropriate sweep speed. The VBW above 1.0 GHz was 3 MHz. The analyzer was calibrated in dB above a microvolt at the output of the antenna. The ambient temperature of the UUT was 83°F with a humidity of 40%.

PRODUCT DESCRIPTION:

The QJEWMC63000902 is a direct sequence spread spectrum radio that operates in the 2410 to 2470 MHz frequency range.

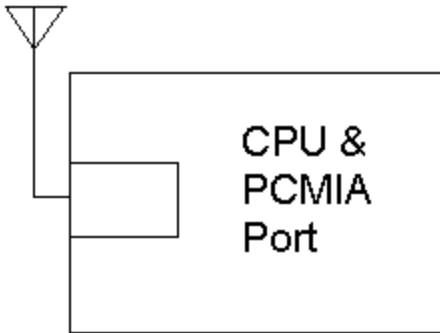

A

APPLICANT: MESH NETWORKS
FCC ID: QJEWMC63000902

RULES PART NUMBER: 15.203 Antenna Connector

This device has an MMCX antenna connector.
This connector is unique and meets the requirement of this section.

NAME OF TEST: POWER LINE CONDUCTED INTERFERENCE
RULES PART NUMBER: 15.107(a)
REQUIREMENTS: .45 - 30 MHz 250 uV OR 47.96 dBuV
TEST PROCEDURE: ANSI STANDARD C63.4-1992. The spectrum
was scanned from .45 to 30 MHz.

TEST DATA:

THE HIGHEST EMISSION READ FOR LINE 1 WAS 33.9 uV @ 16.08 MHz.

THE HIGHEST EMISSION READ FOR LINE 2 WAS 43.2 uV @ 16.08 MHz.

THE PLOTS IN THE FOLLOWING PAGES REPRESENT THE EMISSIONS TAKEN FOR THIS
DEVICE.

TEST RESULTS: Both lines were observed. The measurements indicate
that the unit DOES appear to meet the FCC requirements for this class
of equipment.

POWERLINE CONDUCTED PLOT – LINE 1

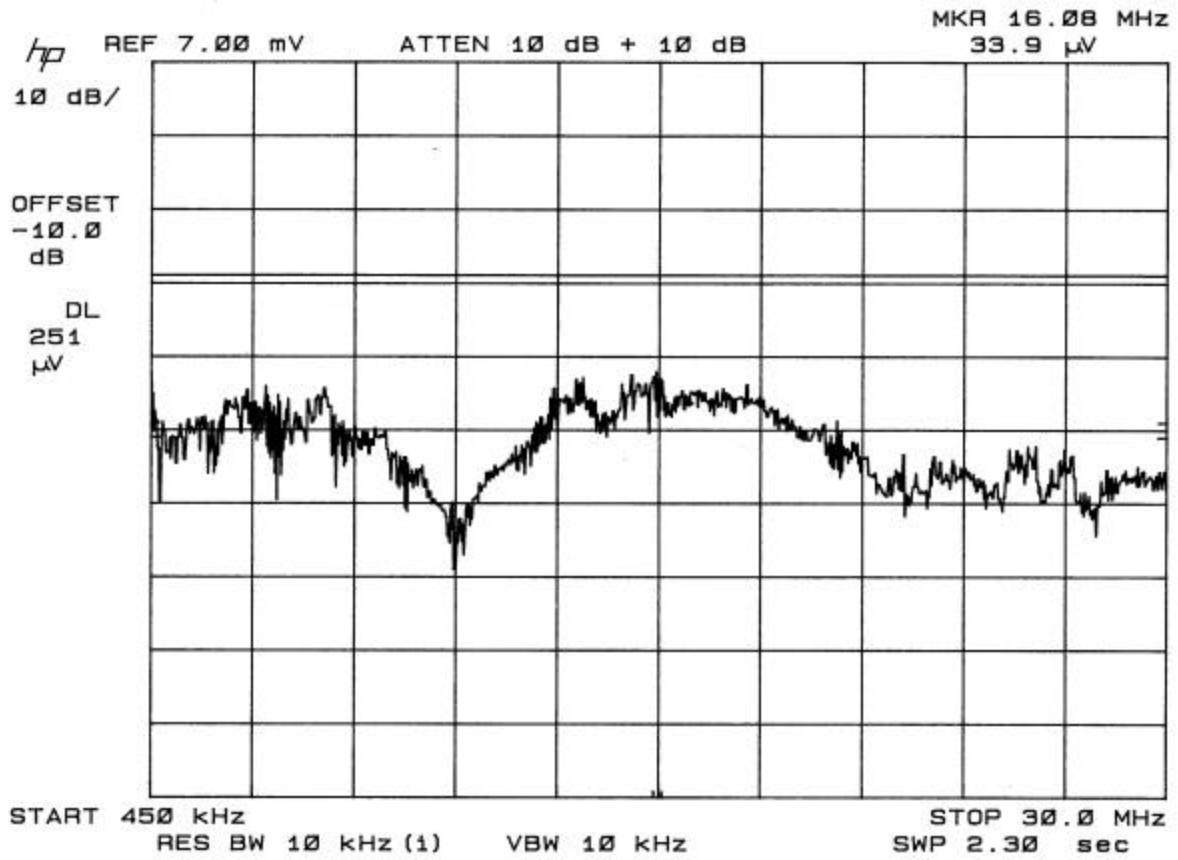

POWERLINE CONDUCTED LINE 2

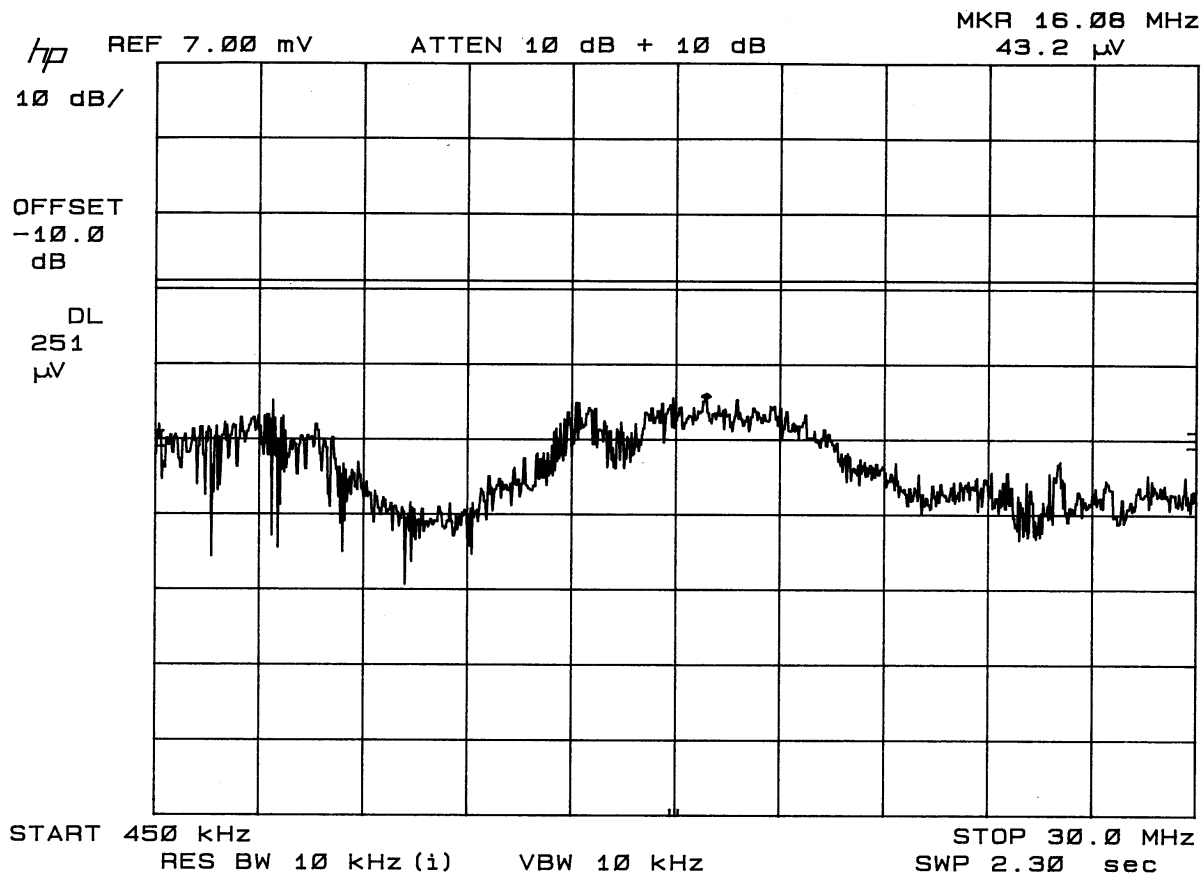

APPLICANT: MESH NETWORKS
FCC ID: QJEWMC63000902
NAME OF TEST: 6.0dB BANDWIDTH
RULES PART NUMBER: 15.247(a)(2)
REQUIREMENTS: The 6.0 dB bandwidth must be greater than 500 kHz.
MEASUREMENT: The 6.0 dB bandwidth measured @ 2432.00MHz was 16.08 MHz.
MEASUREMENT DATA: See the following page.

NAME OF TEST: POWER OUTPUT
RULES PART NUMBER: 15.247(b) 1.0 Watt or +30 dBm
MEASUREMENT: 22 dBm or 160 mWatts @ 2432.0 MHz

15.247(c) Method of Measuring RF Power output:
The Peak power Sensor was connected in place of the antenna.

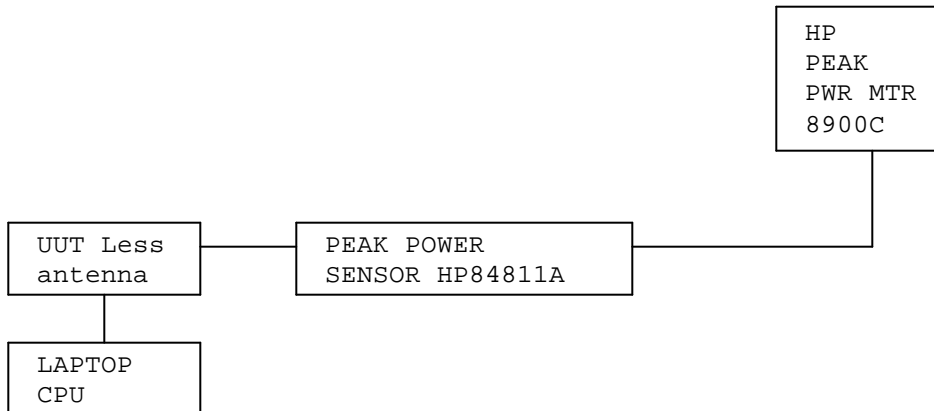

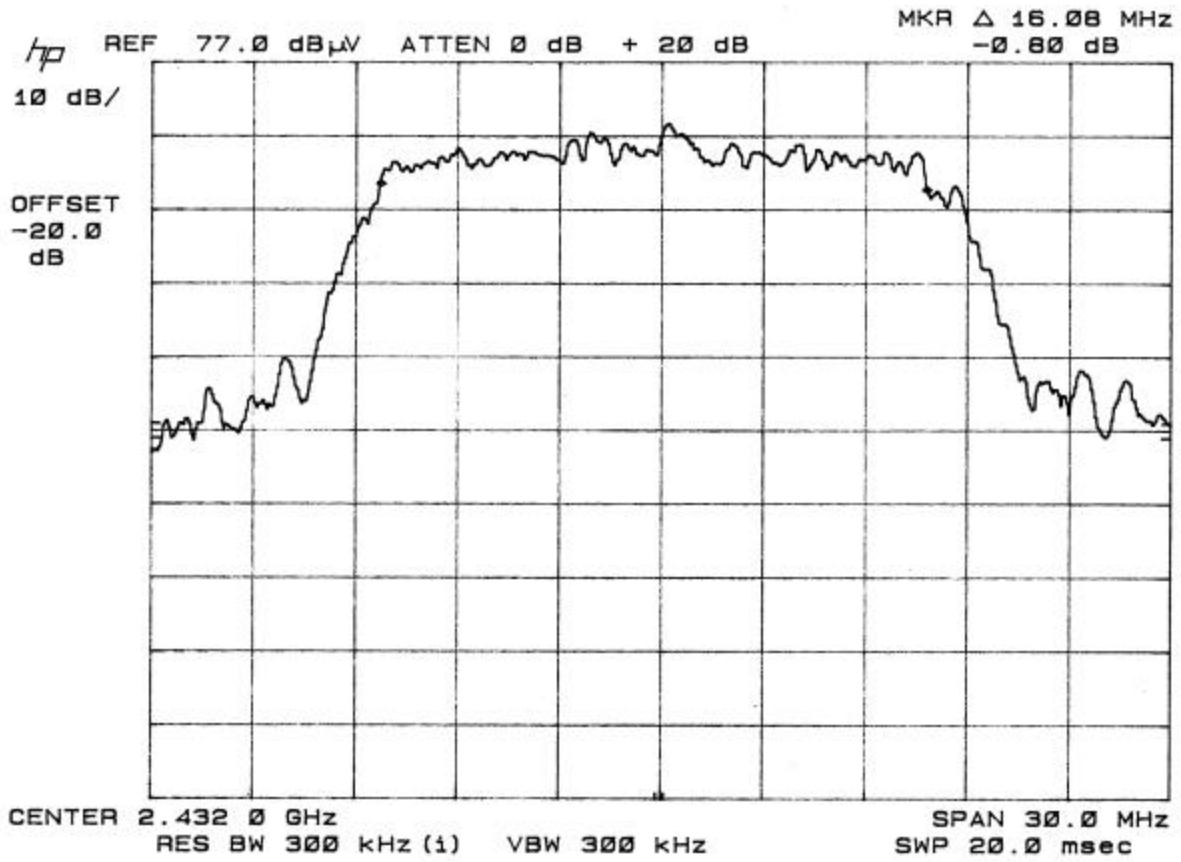

6 dB BANDWIDTH PLOT

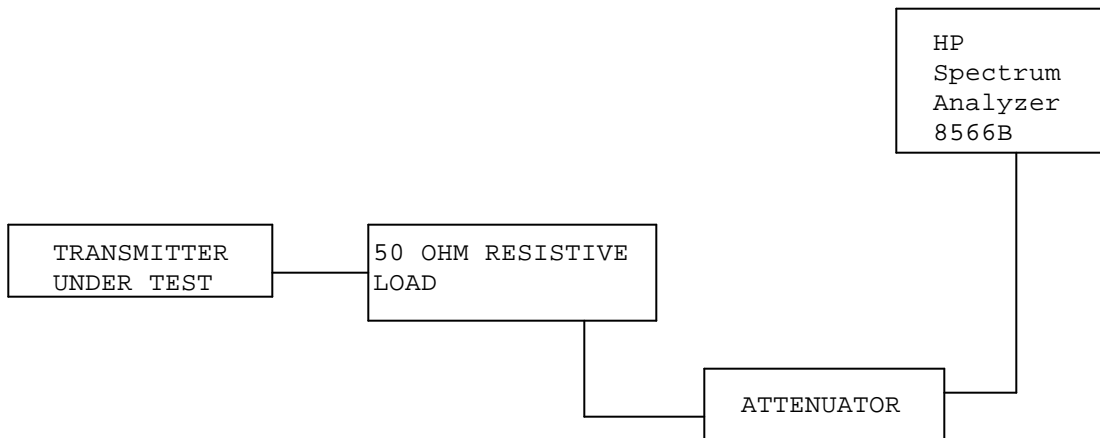

NAME OF TEST: SPURIOUS EMISSIONS AT ANTENNA TERMINALS

REQUIREMENTS: Emissions must be at least 20 dB down from the highest emission level within the authorized band as measured with a 100 kHz RBW. The channel exhibiting the worst-case emissions is reported.

Emission Frequency	dB Below Carrier
2412	0.00
4824	80.80
9648	85
14472	99.6
12083	98.9
16885	104.8
14473	96.6

NOTE: THE SPECTRUM WAS SCANNED TO THE TENTH HARMONIC.

THREE PLACES IN THE BAND WERE MEASURED AND THE WORST CASE DATA PRESENTED HERE.

15.247(c),15.205 &15.209(b) Field strength of spurious emissions:

REQUIREMENTS:

FIELD STRENGTH of Fundamental: 902-928MHz 2.4-2.4835GHz 127.38dBuV/m @3m	FIELD STRENGTH of Harmonics 54 dBuV/m @3m	S15.209 30 - 88 MHz 40 dBuV/m @3M 88 -216 MHz 43.5 216 -960 MHz 46 ABOVE 960 MHz 54dBuV/m
--	---	---

EMISSIONS RADIATED OUTSIDE OF THE SPECIFIED FREQUENCY BANDS, EXCEPT FOR HARMONICS, SHALL BE ATTENUATED BY AT LEAST 50 dB BELOW THE LEVEL OF THE FUNDAMENTAL OR TO THE GENERAL RADIATED EMISSION LIMITS IN 15.209, WHICHEVER IS THE LESSER ATTENUATION.

REQUIREMENTS: Emissions that fall in the restricted bands (15.205) must be less than 74 dBuV/m (peak)
54 dBuV/m (average) otherwise the spurious

Tuned Frequency MHz	Emission Frequency MHz	Meter Reading dBuV	Ant. Polarity	Coax Loss dB	Correction Factor dB	Pulsed CFactor dB	Field Strength dBuV/m Peak	Margin dB
Ground Plane Antenna								
2,410.0	2,262.00R	20.4	V	3.21	28.78	-4.88	47.51	26.49
2,410.0	2,316.00R	20.0	V	3.25	28.82	-4.88	47.19	26.81
2,410.0	2,542.00	12.7	V	3.43	29.13	-4.88	40.38	33.62
2,410.0	2,639.00	20.4	V	3.51	29.48	-4.88	48.51	25.49
2,430.0	2,262.00	20.0	V	3.21	28.78	-4.88	47.11	26.89
2,430.0	2,321.00R	17.5	V	3.26	28.83	-4.88	44.71	29.29
2,430.0	2,651.00	20.4	V	3.52	29.52	-4.88	48.56	25.44
2,430.0	4,820.00R	21.0	V	5.95	33.81	-4.88	55.88	18.12
2,430.0	4,860.00R	18.5	V	6.00	33.85	-4.88	53.47	20.53
2,430.0	9,720.00	10.0	V	8.79	37.92	-4.88	51.83	22.17
2,470.0	2,263.00R	20.2	V	3.21	28.78	-4.88	47.31	26.69
2,470.0	2,330.00R	17.4	V	3.26	28.83	-4.88	44.61	29.39
2,470.0	2,470.00	10.0	H	3.38	28.95	-4.88	37.45	36.55
2,470.0	2,550.00	16.0	V	3.44	29.16	-4.88	43.72	30.28
2,470.0	2,644.00	20.1	V	3.52	29.50	-4.88	48.24	25.76
2,470.0	4,940.00R	22.4	V	6.12	33.92	-4.88	57.56	16.44
Tuned Frequency MHz	Emission Frequency MHz	Meter Reading dBuV	Ant. Polarity	Coax Loss dB	Correction Factor dB	Pulsed CFactor dB	Field Strength dBuV/m Peak	Margin dB
2430.00	4820.00R	18.6	H	5.95	33.81	-4.88	53.48	0.52
2470.00	4940.00R	18.8	H	6.12	33.92	-4.88	53.96	0.04

Notes: Pulsed emissions - The duty cycle correction factor is calculated in a separate exhibit.

Three frequencies in the band were measured and the worst case is presented above. The worst case was found to be per conditions noted below.

*** Because of the unique network properties (described on page one of this report)of this unit. It was tested in this mode which yielded the worst case spurious emissions.

15.247(c), 15.205 & 15.209(b) Field strength of spurious emissions Continued

Tuned Frequency MHz	Emission Frequency MHz	Meter Reading dBuv	Ant. Polarity	Coax Loss dB	Correction Factor dB	Pulsed CFactor dB	Field Strength dBuv/m Peak	Margin dB
Whip Antenna								
2,410.0	2,262.00R	20.6	v	3.21	28.78	-4.88	47.71	26.29
2,410.0	2,316.00R	20.0	v	3.25	28.82	-4.88	47.19	26.81
2,410.0	2,542.00	12.9	v	3.43	29.13	-4.88	40.58	33.42
2,410.0	2,639.00	20.6	v	3.51	29.48	-4.88	48.71	25.29
2,430.0	2,262.00	20.3	v	3.21	28.78	-4.88	47.41	26.59
2,430.0	2,321.00R	17.7	v	3.26	28.83	-4.88	44.91	29.09
2,430.0	2,651.00	20.6	v	3.52	29.52	-4.88	48.76	25.24
2,430.0	4,820.00R	21.1	v	5.95	33.81	-4.88	55.98	18.02
2,430.0	4,860.00R	18.8	v	6.00	33.85	-4.88	53.77	20.23
2,430.0	9,720.00	10.4	v	8.79	37.92	-4.88	52.23	21.77
2,470.0	2,263.00R	20.4	v	3.21	28.78	-4.88	47.51	26.49
2,470.0	2,330.00R	17.7	v	3.26	28.83	-4.88	44.91	29.09
2,470.0	2,470.00	10.0	H	3.38	28.95	-4.88	37.45	36.55
2,470.0	2,550.00	16.0	v	3.44	29.16	-4.88	43.72	30.28
2,470.0	2,644.00	20.7	v	3.52	29.50	-4.88	48.84	25.16
2,470.0	4,940.00R	22.5	v	6.12	33.92	-4.88	57.66	16.34

Tuned Frequency MHz	Emission Frequency MHz	Meter Reading dBuv	Ant. Polarity	Coax Loss dB	Correction Factor dB	Pulsed CFactor dB	Field Strength dBuv/m Peak	Margin dB
2430.00	4820.00R	18.4	H	5.95	33.81	-4.88	53.28	0.72
2470.00	4940.00R	18.6	H	6.12	33.92	-4.88	53.76	0.24

Notes: Pulsed emissions - The duty cycle correction factor is calculated in a separate exhibit.

Three frequencies in the band were measured and the worst case is presented above. The worst case was found to be per conditions noted below.

*** Because of the unique network properties (described on page one of this report) of this unit. It was tested in this mode which yielded the worst case spurious emissions.

METHOD OF MEASUREMENT: The procedure used was ANSI STANDARD C63.4-1992 & the FCC/OET Guidance on Measurements for Direct Sequence Spread Spectrum Systems - Public Notice 54797 Dated July 12, 1995. Measurements were made at the open field test site of TIMCO ENGINEERING INC. located at 849 N.W. State Road 45, Newberry, FL 32669.

Method of Measuring Radiated Spurious Emissions

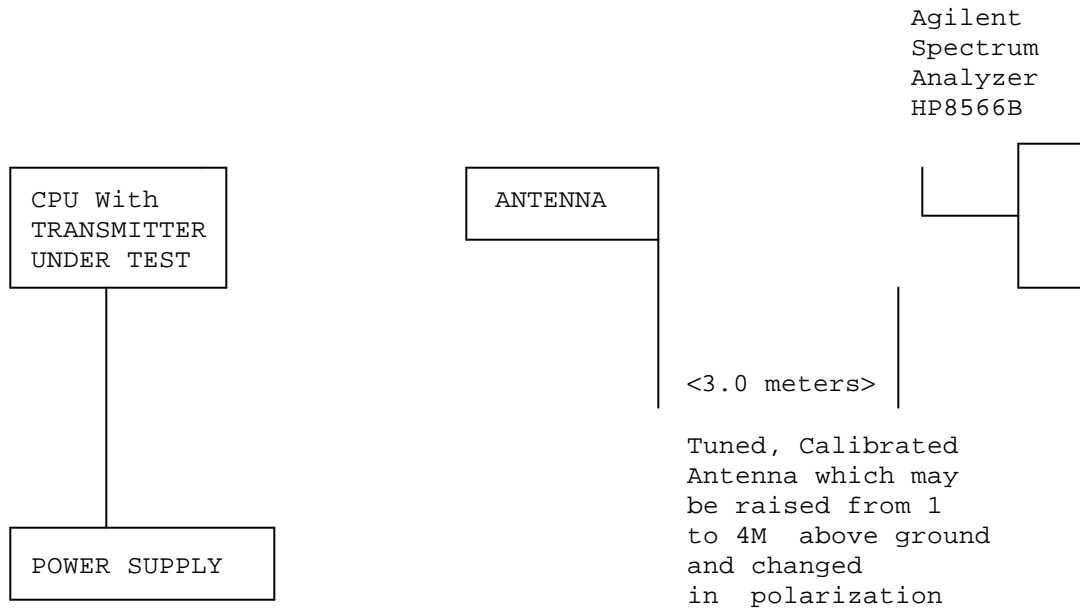

Equipment placed 80cm above ground on a rotatable platform.

APPLICANT: MESH NETWORKS

FCC ID: QJEWMC63000902

NAME OF TEST: RADIATED SPURIOUS EMISSIONS INTO ADJACENT RESTRICTED BAND

REQUIREMENTS: Emissions that fall in the restricted bands (15.205). These emissions must be less than or equal to 500 uV/m (54 dBuV/m).

TEST PROCEDURE: An in band field strength measurement of the fundamental emission using the RBW and detector function required by C63.4-2000 and FCC Rules. The procedure was repeated with an average detector and a plot made. The calculated field strength in the adjacent restricted band is presented below.

GROUND PLANE ANTENNA

Channel frequency: 2410 MHz

Channel frequency: 2470 MHz

Frequency: 2385 MHz

Frequency: 2483.5 MHz

+17.60 dBuV from plot
+28.88 ACF
+ 3.31 Coax loss
- 4.88 Pulsed CFactor
+44.91 dBuV

+25.20 dBuV from plot
+28.95 ACF
+ 3.38 Coax loss
- 4.88 Pulsed CFactor
+52.65 dBuV

WHIP ANTENNA

Channel frequency: 2410 MHz

Channel frequency: 2470 MHz

Frequency: 2381.5 MHz

Frequency: 2468.2 MHz

+25.80 dBuV from plot
+28.88 ACF
+ 3.31 Coax loss
- 4.88 Pulsed CFactor
+53.11 dBuV

-32.30 dBuV from plot
+28.95 ACF
+ 3.37 Coax loss
- 4.88 Pulsed CFactor
-4.86 dBuV

Bandedge measurements were made using special test software that locked the unit on one frequency (2410 or 2470) or the other so that measurements could be made. The duration of these measurements were kept short repeated so as to keep the RF amplifiers from over heating.

APPLICANT: MESH NETWORKS

FCC ID: QJEWMC63000902

REPORT #: M/MeshNetworks\863UT2\863UT2TestReport.doc

BANDEDGE PLOT - GROUND PLANE ANTENNA

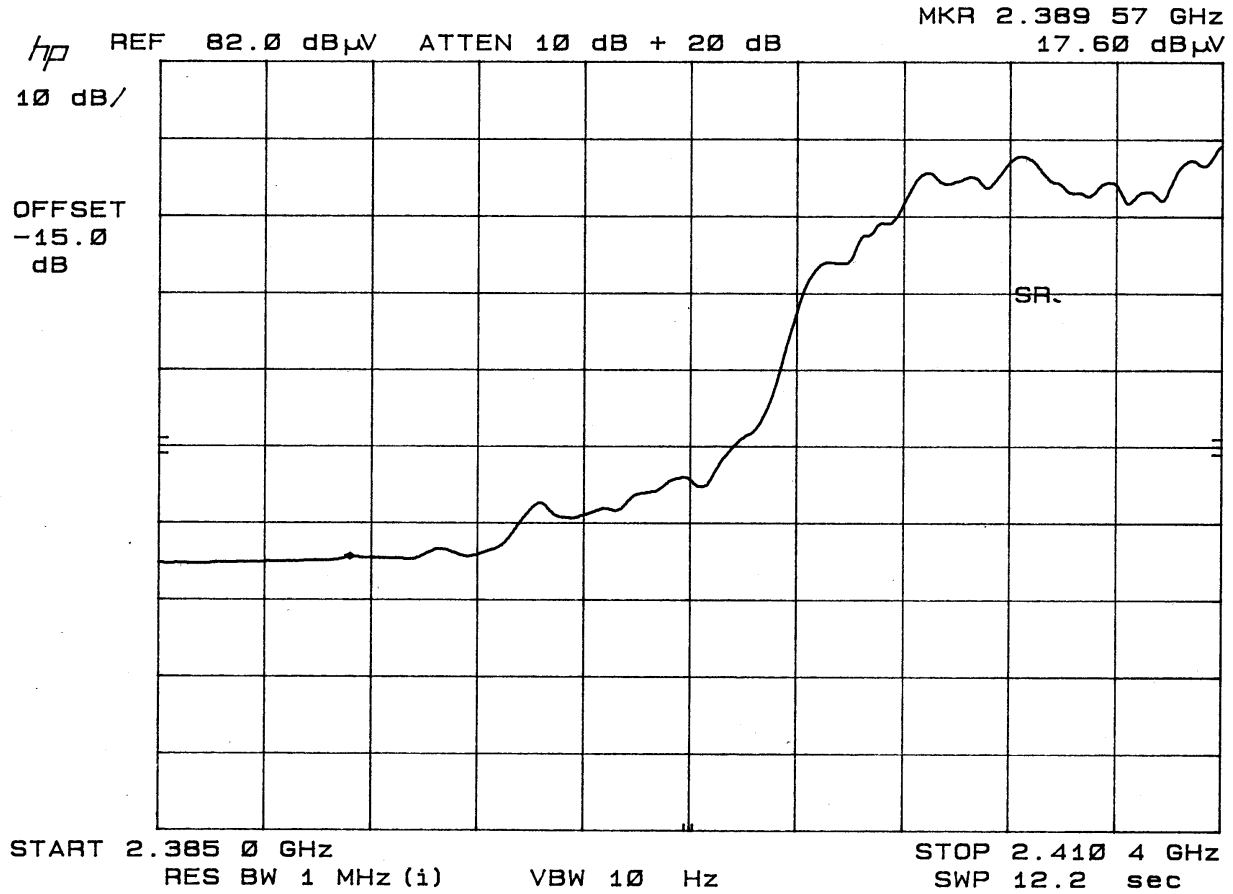

BANDEDGE PLOT – GROUND PLANE ANTENNA

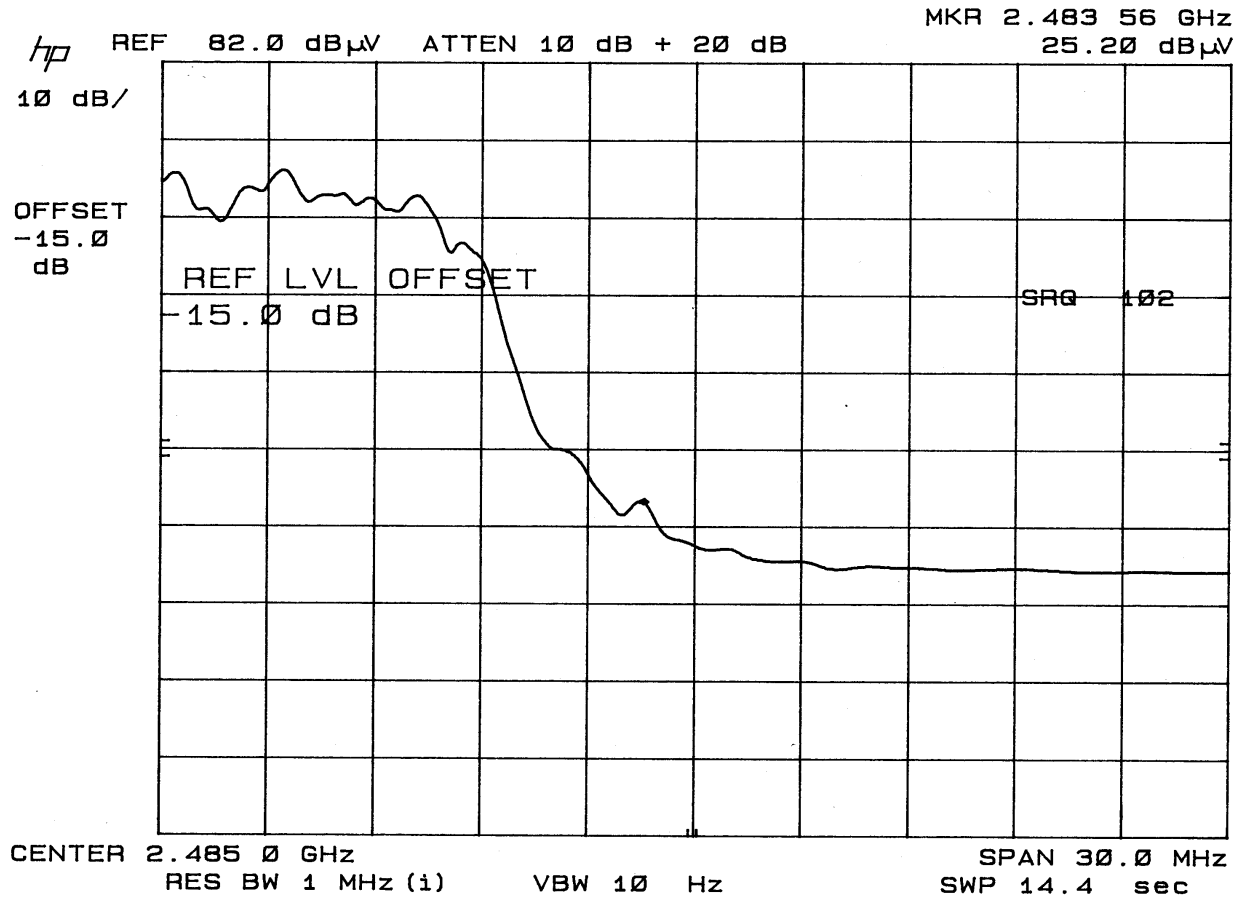

BANDEDGE PLOT - WHIP ANTENNA

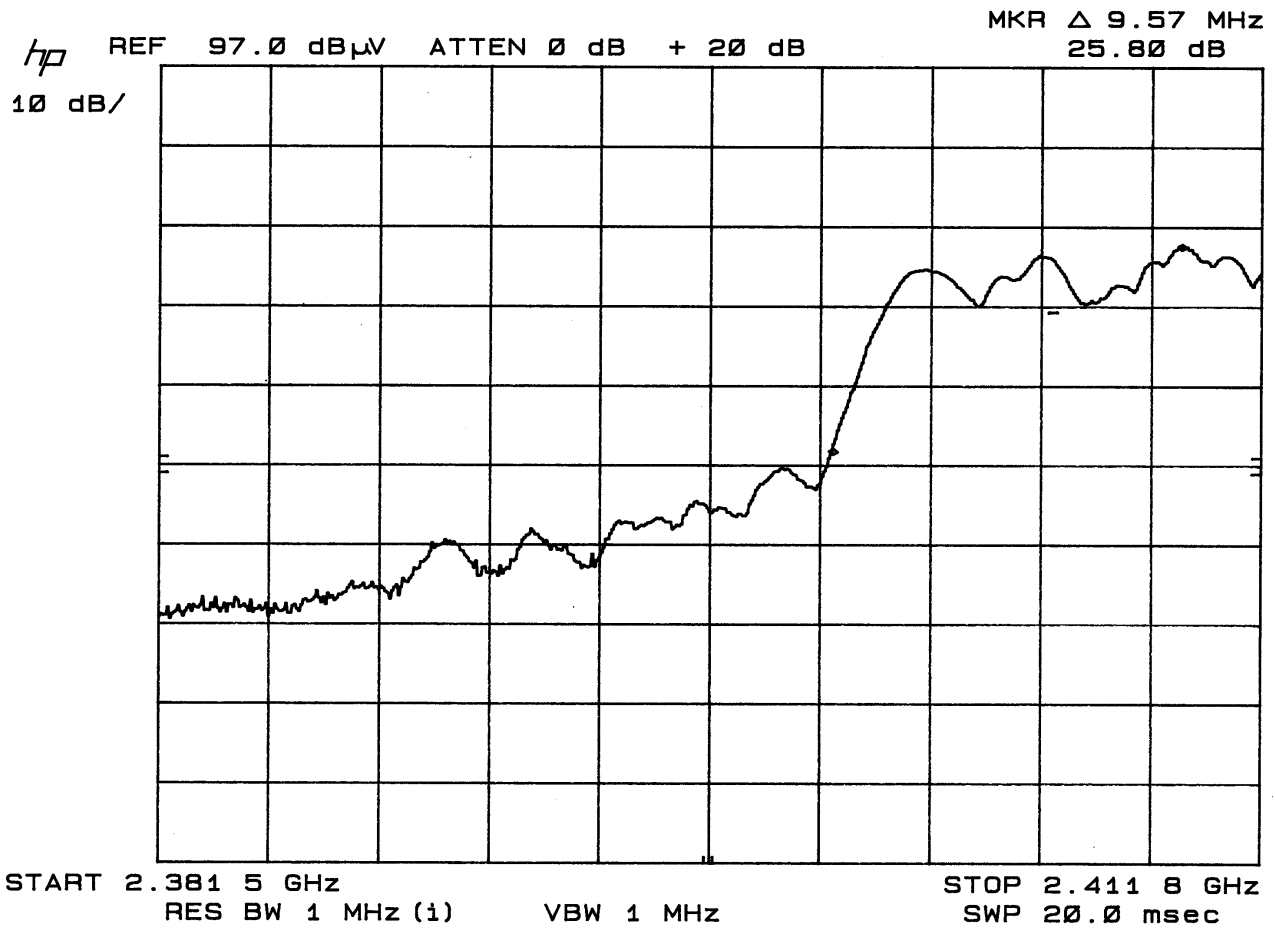

BANDEDGE PLOT - WHIP ANTENNA

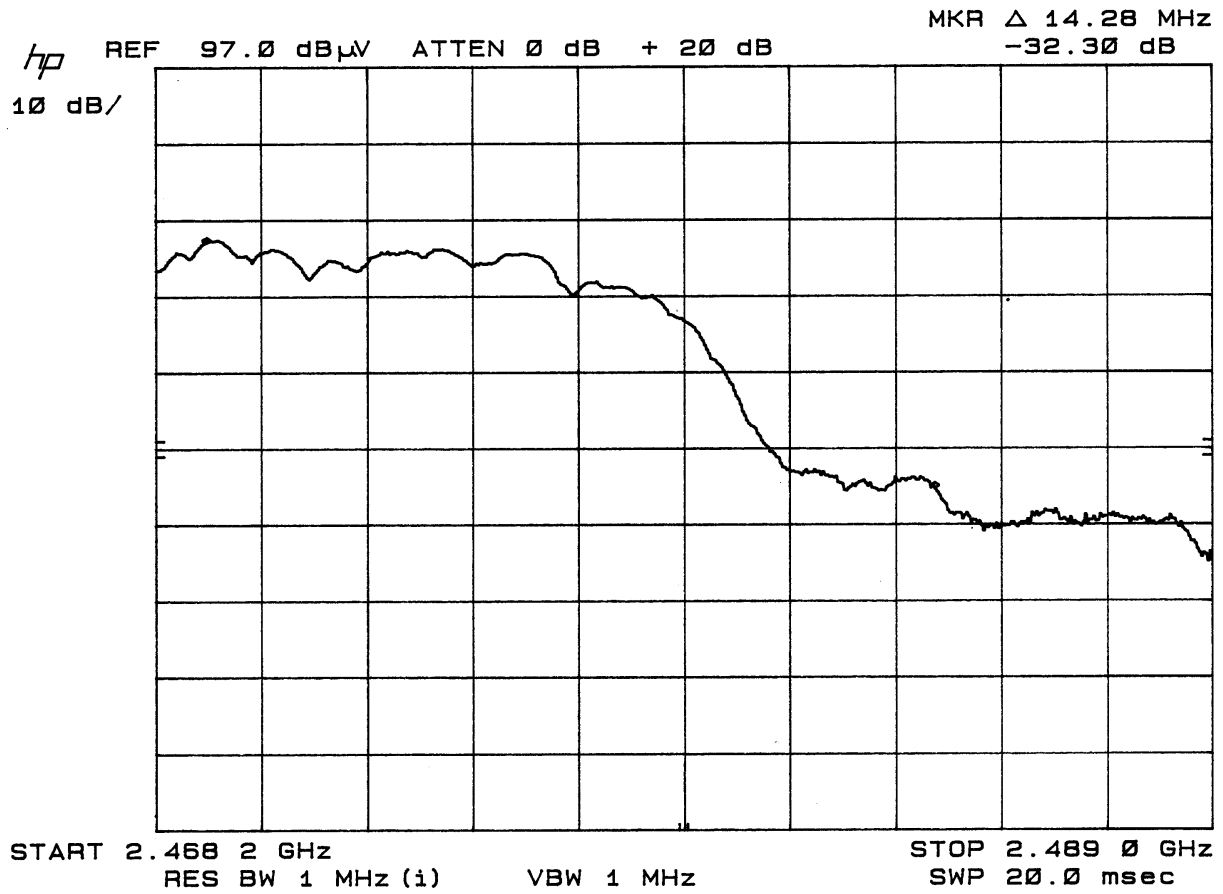

APPLICANT: MESH NETWORKS
FCC ID: QJEWMC63000902
NAME OF TEST: POWER SPECTRAL DENSITY
RULES PART NUMBER: 15.247(d)
REQUIREMENTS: The peak level measured must be no greater than
+8.0dBm.
DATA: THE PLOT IS SHOWN ON THE FOLLOWING PAGE.
The level at 2412 MHz was -63.40 dBm.
-63.4 dBm
+10 dB Attn.
+35 dB Correction Factor
-18.4 dBm

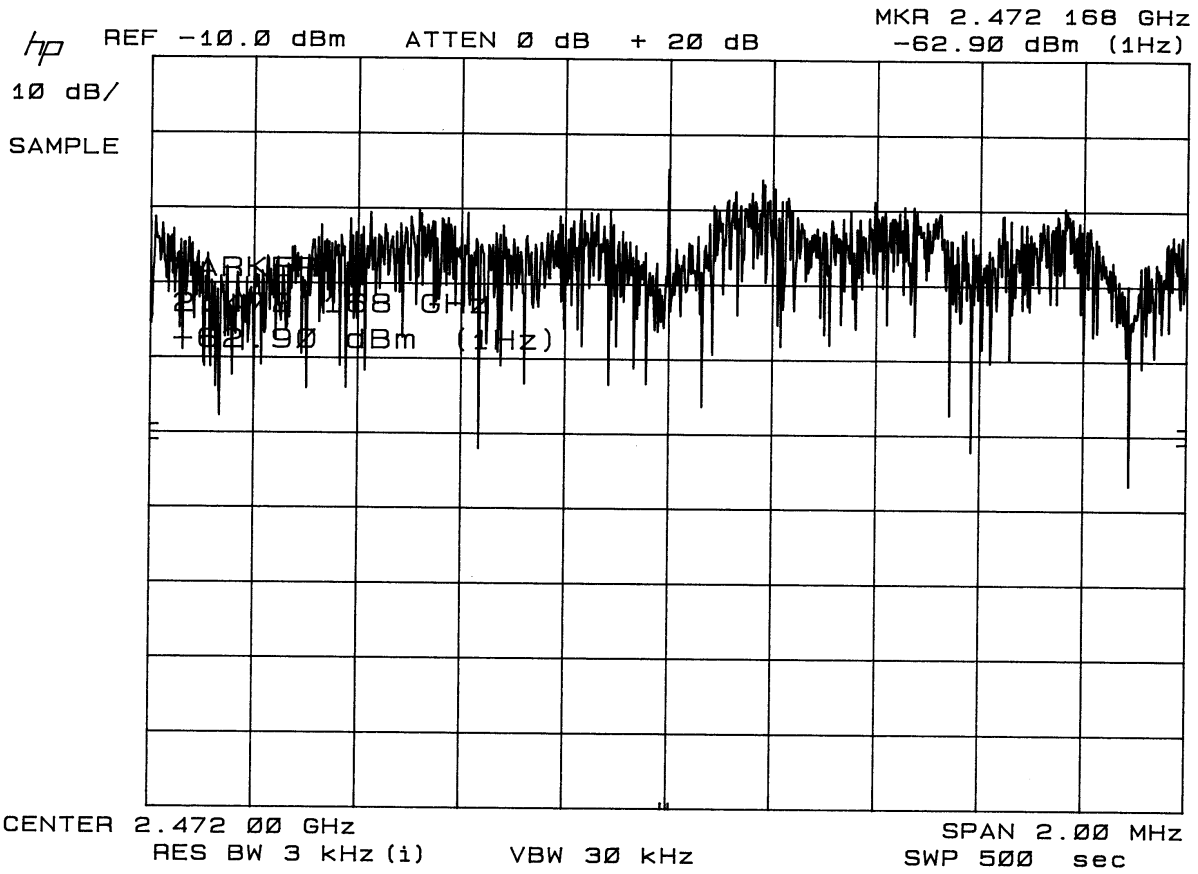

POWER SPECTRAL DENSITY PLOT