

AP 7181 Access Point Installation Guide

Version 1.0.0.A

March 12, 2010

68009287001

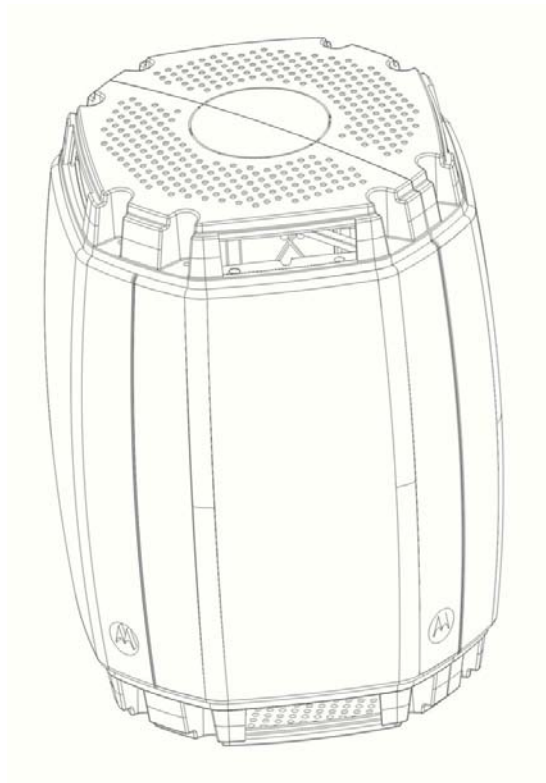

Contents

1	Introduction	1
1.1	Document Conventions	1
2	Hardware Installation	2
2.1	Precautions	2
2.2	Deployment Guidelines	3
2.3	Installation Methodology	4
2.4	Grounding Requirements	4
2.5	Minimum Installation Requirements	5
2.6	Package Contents	5
2.7	Access Point Placement	5
2.7.1	Site Surveys	5
2.7.2	Root Node Placement	6
2.7.3	Non Root Node Placement	6
2.7.4	Mounting Locations	7
2.7.5	Device Deployment Height	7
2.8	Antenna Options	8
2.9	AP 7181 Power Options	8
2.9.1	Power Cables	8

2.10 Mounting an AP 7181	9
2.10.1 Pole Mounted Installations.	10
2.11 Installing an AP 7181	10
2.11.1 Required Tools	10
2.11.2 AP 7181 Connections and Ports.	11
2.11.3 LED Status Indicator Panel	14
2.11.4 Removing the AP 7181 Kit from the Shipping Carton	15
2.11.4 Staging the Device Prior to Installation	17
2.12 Field Installation	24
2.12.1 Bottom Mount Installation.	25
2.12.2 Top Mount Installation.	33
2.13 Remote Panel Antenna Installation.	42
2.13.1 Preparing the AP 7181	45
2.13.2 Installing the Remote Panel Antenna.	47
2.13.3 Installing the Blank Antenna Panel	51
3 Getting Started	55
3.1 Initially Connecting to the Access Point.	55
3.1.1 Connecting to the Access Point Using the WAN Port. .	56
3.1.2 Connecting to the Access Point Using the LAN Port . .	57
3.2 Basic Device Configuration	59
3.2.1 Configuring Device Settings	61
3.2.2 Configuring WLAN Security Settings.	69
3.2.3 Creating a Secure Recovery WLAN	71
3.2.4 Testing Connectivity	77
3.2.5 Creating a Mesh Point	78
3.3 Where to Go From Here?	84

4 Regulatory Compliance	85
4.1 Health and Safety Recommendations	85
4.1.1 Warnings for the Use of Wireless Devices	85
4.1.2 Potentially Hazardous Atmospheres	85
4.1.3 Reducing RF Exposure - Use Properly	85
4.2 Power Supply	85
4.3 FCC Regulatory Information	86
4.3.1 RF Exposure	86
4.3.2 Intentional and Unintentional Radiators	86
4.3 Canada Requirements	86
5 Customer Support	87

MOTOROLA and the Stylized M Logo are registered in the US Patent & Trademark Office. All other product or service names are the property of their respective owners. © Motorola, Inc. 2010. All rights reserved.

1 Introduction

The purpose of this document is to provide installation and setup procedures for Motorola's AP 7181 Access Point.

The AP 7181 is a wireless broadband data system that uses mesh networking technology to support wide-area broadband data coverage. The system offers both 2.4 GHz 802.11b/g/n and 5.x GHz 802.11n Wi-Fi client access with 2.4 GHz 802.11 b/g/n and 5.x GHz 802.11a/n meshing. The dual-band system supports industry standard client devices and features easily deployed fixed infrastructure nodes.

The AP 7181 is also designed to meet the needs of large, distributed outdoor networks. The network can be configured and managed for optimal performance using the Wireless Manager (WM) network Management application.

The most current versions of this manual and other AP 7181 documentation can be found at:

<http://motorola.wirelessbroadbandsupport.com/support/mesh/library>

1.1 Document Conventions

The following graphical alerts are used in this document to indicate notable situations:



NOTE Tips, hints, or special requirements that you should take note of.



CAUTION Care is required. Disregarding a caution can result in data loss or equipment malfunction.



WARNING! Indicates a condition or procedure that could result in personal injury or equipment damage.

2 Hardware Installation

An AP 7181 access point installation includes mounting the access point, connecting the access point to the network, and applying power. Installation procedures vary for different environments.

2.1 Precautions

Before installing an AP 7181 model access point verify the following:

- Become familiar with grounding requirements (see *Grounding Requirements*).
- Verify the environment has a continuous temperature range between -40°C to 55°C .

AP 7181 devices must be installed by trained professionals familiar with RF planning and regulatory limits defined by the regulatory bodies of the country where the devices are being deployed. All common precautions for grounding and ESD (Electrostatic Discharge) protection should be observed during deployment and installation. AP 7181 devices are designed to be installed outdoors and must be installed such that no harmful interference results from device operation.



CAUTION All device wiring must comply with the National Electric code (NEC) or regulations and procedures defined by the regulatory bodies of the country or region where the devices are being deployed. All local building and structure codes must be observed.



WARNING! Strictly observe the following Safety Precautions during the AP 7181 Installation Procedure.

- Installations must be performed by professionals who are properly trained and certified.
- Avoid contact with overhead power lines.

- Take precautions to avoid injury from falling tools and equipment. Crews should wear hardhats in and around the installation work site.
- Be aware of vehicular traffic in and around the installation work site.
- Do not hold any component containing a radio such that the antenna is very close to or touching any exposed parts of the body, especially the face or eyes, while transmitting.
- Do not operate a portable transmitter near unshielded blasting caps or in an environment where explosives are present unless the transmitter is especially certified for such use.

2.2 Deployment Guidelines

Observe the following recommended guidelines to help ensure a successful network deployment:

- Mounting height for network devices should not exceed 30 to 35 feet. Mounting height should vary to accommodate the topography of the deployment area, foliage, and other obstructions.
- Devices can be deployed using either the *Bottom Mount Installation* or the *Top Mount Installation* procedure.
- Point-to-Point (PTP (*Slave*)) or Point-to-Multipoint (PMP (*SM*)) nodes providing backhaul should be oriented to point away from AP 7181 antenna panels.



NOTE For more detailed deployment considerations for backhaul, refer to the *Mesh AP 7181 System Planner*.

- Custom stand-off brackets should be used as required to provide adequate pole separation in an effort to minimize reflective received power.
- LoS guidelines should be given special consideration whenever devices will not be installed in a straight line, such as deploying devices on alternating sides of a roadway.
- Ensure that all Root nodes are deployed with line of site to the wireless backhaul cluster points.

2.3 Installation Methodology

Consideration of the order in which units are installed when deploying an AP 7181 wireless network can work to ensure a more stable and functional network. The PTP backhaul layer should be deployed first. Next deploy all nodes for the PMP Access Point distribution layer. Next deploy Root nodes along with PMP Subscriber Modules (SMs) such that backhaul and network connectivity can be verified or corrected. Finally, deploy all Mesh Point wireless nodes in order of the least to most hops (1 hop nodes first, followed by 2 hop nodes, etc.).

2.4 Grounding Requirements

To avoid damage to the equipment, become familiar with Motorola Policy R56 before installing AP 7181 units. Refer to *Standards and Guidelines For Communication Sites, Version B*. Both the hardcopy manual (Part Number 68P81089E50-B) and the CD version (Part Number 9880384V83) can be ordered from Motorola.

Section 7.6.4 Broadband - Wireless Access Point Network from the *Standards and Guidelines For Communication Sites* applies directly to AP 7181 deployments:

SPD (Surge Protection Device) considerations for broadband shall include the use of SPDs to protect pole-mounted access points and ground-based cabinet architecture. It is important to install proper SPD applications on both ends of Ethernet, Power-Over Ethernet (POE), Giga-Ethernet (GigE) and AC cable runs. SPDs shall be located within the node or cabinet, or as close to the entrance as possible, and properly installed into load centers, control panels and utility power cabinets. While RF protection is a consideration, it shall only be required when antennas are connected to the node with coaxial cables greater than 610 mm (2 ft.) in length.



CAUTION It is required that all root and portal nodes be adequately grounded. In addition, all root nodes and portals using the Ethernet port or attached devices (e.g. a camera) *must* not only be grounded, but they should also include surge suppression for network reliability. This is particularly important for network configurations with a public safety component.

When grounding a unit installed on a wooden pole, a ground conductor and rod is required. This requirement should be factored into the project deployment costs, particularly if the equipment must be installed by a utility company.

2.5 Minimum Installation Requirements

The minimum requirements for installing an AP 7181:

- AP 7181 Access Point
- Power Cable (Flying Leads)
- Standard Ethernet cable
- Yoke (attached)
- 22 mm Socket and driver to remove port caps
- #6 metric Allen Wrench to remove the Yoke (if a top mounted installation is required)

2.6 Package Contents

Check the package contents for the AP 7181. Each unit should contain:

- AP 7181 Access Point (assembled with Mounting Yoke attached)
- Power Cable
- Optional accessories (in a separate box inside the AP 7181 shipping container)

Contact the Motorola Support Center to report missing or improperly functioning items. Refer to *Customer Support*.

2.7 Access Point Placement

Typically, roadways in the deployment area become main arteries for the wireless mesh network. Roadways can provide LoS coverage over large distances between Root and Non Root APs.

2.7.1 Site Surveys

Motorola recommends conducting a site survey prior to installing an access point. A thorough site survey must include a visit to the customer site to identify the characteristics of the coverage area, including availability of electrical distribution for power sources and the location of existing network infrastructure. The site survey should also include preliminary WLAN measurements to identify candidate AP locations

When scheduling a visit to conduct a site survey, request access to wiring closets, adjacent floors, and other locations that may require special permission.

2.7.2 Root Node Placement

When planning for Root Node placement:

- Identify Root node wireless backhaul technology (Point-to-Point (PTP), Point-to-Multipoint (PMP)).
- Identify Ethernet or fiber optic backhaul.
- Identify Root node locations.
- Obtain all required permits and/or lease agreements.
- Verify that power is available at each potential node deployment location.
- Give careful consideration to the fact that Root nodes with a wireless backhaul usually backhaul traffic to a cluster point (i.e. PMP Canopy).
- Wireless backhaul clusters can be on towers, rooftops, etc.
- Ensure that all Root nodes are deployed with LoS to cluster points.

2.7.3 Non Root Node Placement

The same guidelines as Root nodes apply with the exception of a backhaul requirement

The placement of Non Root nodes will depend heavily on the RF network design. Consider the guidelines for optimizing wireless network performance when identifying potential mounting sites.

In addition, consider the following when planning for Non Root node placement:

- Light Poles, Utility Poles, or Traffic Poles
 - Obtain all required supplemental agreements from local governments and utilities.
 - Obtain a generic mounting agreement that is not specify specific poles, since installation locations may need to be modified during deployment.
 - Plan for AC power usage of 84 watts average, 126 watts peak.
 - The AP 7181 is rated for wind loading of up to 160 mph.
 - Ensure that proper grounding can be established.
- Rooftops and Towers
 - May require lease agreements.
- Identify AP locations based on optimal communication with the Root nodes.
 - Non Root node placement will be dependent on asset availability, terrain, etc.

- Ensure that nodes are placed at the same height.
- Build the network outward from each root node, from least to greatest number of hops.

As with Root nodes, it should be noted that it is incumbent upon the customer to obtain the required Pole Attachment Agreements for devices to be installed on traffic / utility poles. Obtaining the agreements can be a lengthy process, so ample lead time must be allowed.

The potential pole locations should be logged with GPS to obtain accurate coordinates. Also log any identifying numbers on the pole so that this information can be provided to the appropriate utility agency. Alternate mounting locations should also be identified in the event that your initial request is denied.

Specialized brackets may be required for attaching devices to decorative light poles and these brackets may have to be custom fabricated. If this is the case, allow enough lead time for ordering the proper equipment.

Also consider any requirements to coordinate requests with multiple utility agencies within the same community. Verify that light pole selections have power available continuously and that the power source is within the operational range of the device being connected.

2.7.4 Mounting Locations

To avoid distortion of the RF pattern, device locations should be chosen such that the AP 7181 ADvanced Element Panel Technology (ADEPT) antenna panels are at least 30 inches from any nearby metal poles and not co-located or operating in conjunction with any other antenna or transmitter. The antenna panels must also have a separation distance of at least 2 meters from anyone who may come into proximity of the AP 7181.

2.7.5 Device Deployment Height

AP 7181 nodes are typically mounted at a height of 30 to 35 feet. Ensure that neighboring nodes are mounted at or near the same device height.

Excessive height should be avoided since this may result in increased congestion and interference in dense RF environments. This is especially true for the 2.4 GHz band.

Nodes deployed with too great a difference in height or too close to each other may not mesh properly.

Always consider these general guidelines for device deployment height:

- Maintain a typical deployment height of 30 to 35 feet.
- For optimum performance, ensure that devices are oriented to have LoS to all neighboring devices.
- Locate Root Nodes which support Wireless Backhaul so that they have LoS to Backhaul clusters or PTP locations, such as towers.

2.8 Antenna Options

The AP 7181 features an integrated ADvanced Element Panel Technology (ADEPT) antenna system that is designed to take full advantage of the 802.11n radios. No other antennas are supported.

2.9 AP 7181 Power Options

Details of the power sourcing equipment for the AP 7181 should be handled by a professional installer. The requirements for deploying the system are:

- Over current protection device with a maximum rating of 20 Amps.
- AP 7181 AC Model - 100-240 VAC input capable of sourcing 180 watts.
- AP 7181 DC Model - Nominal 48 Volt Power source (41-58 VDC) capable of sourcing 150 watts. Battery floating voltage should not exceed 60 VDC.

2.9.1 Power Cables

Flying lead power cables are available based on the country of operation.

Four Wire AC Right Angle Power Cable (North America and International)	Black (Line) White (Neutral) Red (Unused) Green/Yellow (Ground)
Three Wire AC Power Cable (International)	Brown (Line) Blue (Neutral) Green/Yellow (Ground)
Two Wire DC Power Cable (North America and International)	Black (Negative) Red (Positive)



CAUTION Never plug a power cable wired to a power source for an AC unit into a DC unit.

If the units will be plugged directly into an electrical wall outlet, power plug adapters are available for North America, Europe, and Australia.



CAUTION Do not use the connector on the power cables for interrupting current. Never actively plug or unplug the connector while the cable is energized.

2.10 Mounting an AP 7181

The AP 7181 is designed for outdoor installations. All hardware installations should be performed by a professional installer.

Devices can be deployed using either the *Bottom Mount Installation* or the *Top Mount Installation* procedure.

Mounting options are available for light pole, building roof tops, and building walls. Choose one of the following mounting options based on the physical environment coverage area requirements.

2.10.1 Pole Mounted Installations

The optional Wall Gooseneck can also be used with the Pole Adapter for pole mounting.



The Wall Gooseneck dimensions are 10x12x6 inches and it weighs 4 pounds. The Pole Adapter dimensions are 4x2.62x7 inches and it weighs 3 pounds.

The Gooseneck attaches to the Yoke, which can be attached to the top or the bottom of the AP 7181. Secure the Gooseneck and adaptor to the pole using band clamps with the threaded portion pointing either up or down.

If using a bottom mount, drill a 1/4 inch diameter hole at the lowest point on the bend to allow water to drain from the Gooseneck.

2.11 Installing an AP 7181

The following guidelines and procedures should be observed when installing an AP 7181 device.

2.11.1 Required Tools

The following is a list of the minimal tool set required to install an AP 7181 device:

- 24 mm Socket and driver - for cable gland
- 22 mm Socket and driver - for GE1 and GE2 port caps
- 19 mm Socket and driver - for Console port cap
- 21 mm Socket and driver - for set screw
- 8 mm Socket and driver - for ground screw
- 6 mm Allen Wrench bit - for mounting bracket (Yoke)
- T27 Torx bit - for the Sun Shields

- Torque Screwdriver - for the Sun Shields
- Torque Wrench
- Adjustable Wrench
- Standard Level
- Tube of Lithium Grease

2.11.2 AP 7181 Connections and Ports

The power cable and grounding connections, power indicator light, Ethernet and reset ports, and LED Status Panel on the bottom the AP 7181 are shown in the figure below.



The Horizontal (HP) and Vertical (VP) connectors for the antenna cables are located on the top of the AP 7181.

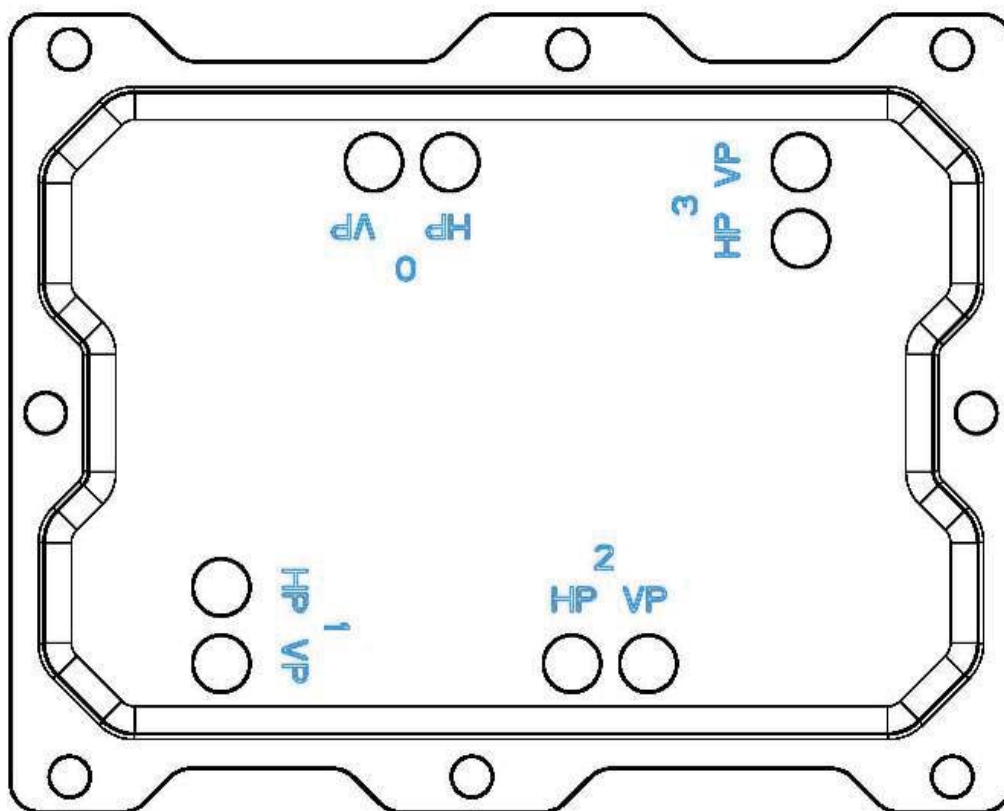

All Radome antenna panel cables are labeled as HP or VP. Attach each cable to the corresponding connector when performing a *Remote Panel Antenna Installation* or any other procedure which requires attaching antenna cables to the connectors.



WARNING! When disconnecting the antenna cables from the unit or removing an antenna panel and replacing it with a Blank panel, terminators **MUST** be placed on the unused horizontal and vertical connectors on the top of the unit.



CAUTION It is also recommended that the antenna cable connectors and terminators on the horizontal and vertical connectors on the top of the AP 7181 be wrapped with both mastic tape and electrical tape.



2.11.3 LED Status Indicator Panel

There are six LEDs on the AP 7181 which are visible on the bottom of the unit through light pipes. The LEDs have the following display characteristics and functionality:

<i>LED 1</i>	<i>LED 2</i>	<i>LED 3</i>	<i>LED 4 - 5 GHz</i>	<i>LED 5 - 2.4 GHz</i>	<i>LED 6</i>
Blinking Red indicates booting. Solid Red defines a failure condition. White defines normal operation	Green defines normal GE1 operation. Yellow defines a collision	Green defines normal GE2 operation. Yellow defines a collision	Amber defines 5 GHz radio as configured.	Emerald defines 2.4 GHz radio as configured.	Not used

2.11.4 Removing the AP 7181 Kit from the Shipping Carton



CAUTION Never lift an AP 7181 using the Radome antenna panels or other plastic parts. Always lift the unit by the Yoke or metal antenna rings.



WARNING! An AP 7181 weighs 39 pounds. Use all appropriate cautions when lifting and consider a two man lift when necessary.

1. Open the shipping carton and remove top packaging material.



2. Remove the accessories pack from the shipping carton.



In the accessories box, you will find the following items:

- Water Proof Ethernet Adaptor (Cable Gland) (Part number: 09009302001)
- Power Cable (Part number: 30009307001, 30009308001, or 30009315001)
- Sun Shields with Captive Screws (Part number: HKLN4446A)



3. Open the plastic bag covering the unit.
4. Roll the plastic bag to the bottom of the shipping carton and using the Yoke or Antenna Ring, carefully remove the unit from the box . Using this method will help prevent damage to the antenna assembly.

2.11.5 Staging the Device Prior to Installation



WARNING! An AP 7181 weighs 39 pounds. Use all appropriate cautions when lifting and consider a two man lift when necessary.

1. Place on solid surface with the Yoke facing up.



CAUTION Never lift an AP 7181 using the Radome antenna panels or other plastic parts. Always lift the unit by the Yoke or metal Antenna rings.

2. Using the 6mm Allen Wrench, loosen the Allen head bolts to remove the Yoke.



3. To gain access to the Ethernet and or console ports you will need to remove the protective caps. A 22 mm socket will be required to remove the Ethernet port caps covering Gigabit Ethernet ports GE1 and GE2. A 19 mm socket is required to remove the console port cap (if required).



4. Using the 22 mm socket remove the port caps for Gigabit Ethernet GE1 and GE2.



5. Remove the cap on the cable gland as shown below.



- Carefully hand tighten the gland into Gigabit port GE1. Once the gland is snug, use a 24 mm socket and finishing tighten the gland.



If the node is going to be configured as a **Mesh Point Root** node (Mesh Point Root nodes have a direct wired Ethernet connection to the core network or an Ethernet connection to a wireless backhaul) a cable gland will be required for Gigabit Ethernet port GE1.

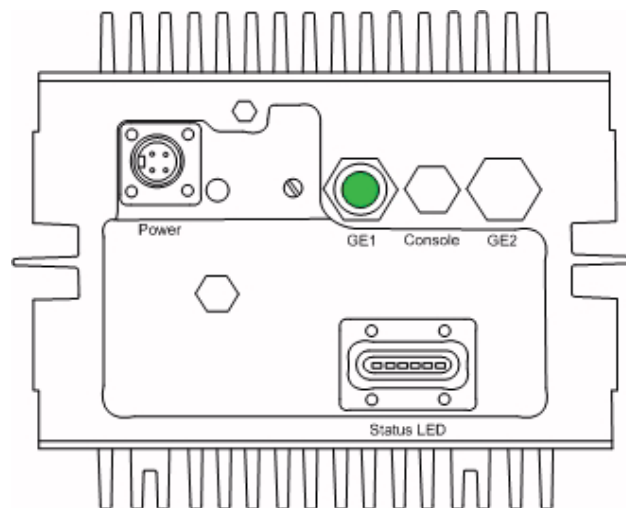

Mesh Point Root

If the **Mesh Point Root** node is also going to have an external device attached (e.g. surveillance camera) an additional cable gland will be required for Gigabit Ethernet port GE2 (make sure the WAN port GE2 has been configured to permit an attached external device during the configuration process).



NOTE The AP 7181 supports 802.af compliant Power over Ethernet (PoE) on Ethernet port GE1 and can provide power to an external PoE capable device such as a surveillance camera. PoE is auto sensing and is enabled when the AP-7181 senses a PoE capable device.

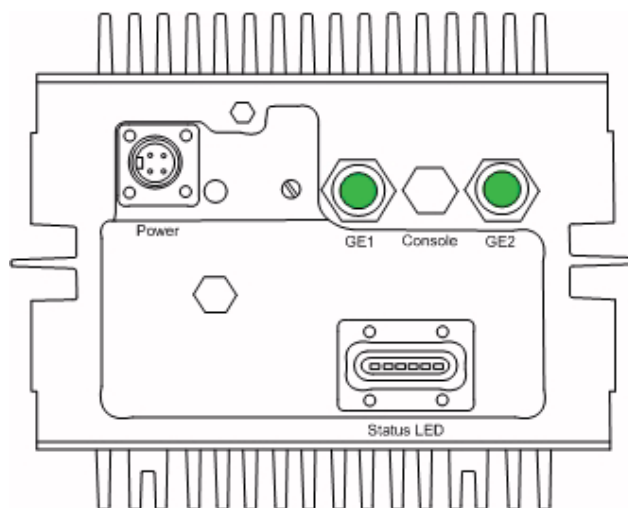

Mesh Point Root
Camera Ready

If the device being staged is a **Mesh Point** node (no wired connection to the core network) and no external device is going to be attached then no cable glands are required.

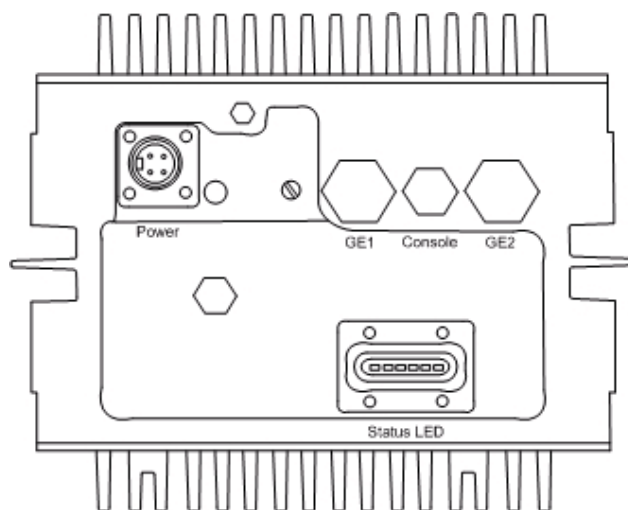

Mesh Point

If the Mesh Point node is going to have an external device attached (e.g. surveillance camera) a cable gland is required for Gigabit Ethernet port GE1.

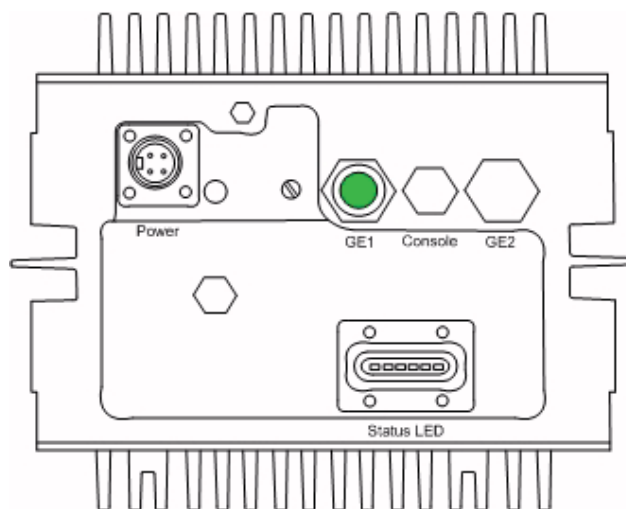

Mesh Point
Camera Ready

7. Repeat the process if a second cable gland is required.



8. Attach an Ethernet cable to Gigabit Ethernet port GE2 (to be used with an external laptop for configuring the unit). You will also need to terminate the flying lead power cable with the proper plug (for the country of operation) so the unit can be powered for configuration. After preparing the power cable attach the cable to the power port. Notice that the power connector is keyed. Next configure the unit. Refer to *Getting Started* for initial device configuration.



9. After the unit has been configured, if the GE2 port is not going to be used to attach an external device to the AP7181, reattach the port cap. If the GE2 port is going to be used to attach an external device, attach the cable gland to the GE2 port.



10. Reattach the Yoke.



11. Return the unit to the shipping carton for transport to the installation site. Due to the nature of the electronic components and antenna array, using the shipping carton is the most secure method for transport.

2.12 Field Installation



CAUTION Observe the following precautions to avoid damage to the unit during installation.

- Only trained and qualified personnel should install this equipment.
- Only a licensed electrician should install power cable / energize circuits.
- All device wiring must follow the National Electric Code (NEC) or wiring requirements in the country of installation. All location building and structure codes must be observed.
- Ensure that the power source for the AP 7181 is de-energized prior to installation.



WARNING! Observe the following safety precautions to avoid personal injury during installation.

- Avoid exposure to high voltage power sources.
- Avoid contact with overhead power lines.
- Avoid falling tools or equipment.
- Be aware of vehicular traffic in the vicinity of the work area.



WARNING! When disconnecting the antenna cables from the unit or removing an antenna panel and replacing it with a Blank panel, terminators **MUST** be placed on the unused connectors on the top of the unit.



CAUTION It is also recommended that the antenna cable connectors and terminators on the horizontal and vertical connectors on the top of the AP 7181 be wrapped with both mastic tape and electrical tape.

2.12.1 Bottom Mount Installation

The pole mount adapter (Part Number RLN6197A) will accommodate a banding strap up to 1¼ inch width. Banding straps and the banding tool are not included when ordering the pole mount adapter.



The pole mount adapter can be mounted to poles 3 inches to 15 inches in diameter and has a load rating of 75 lbs.

1. Attach the pole mount adapter (or other mounting bracket hardware) to the mounting asset and ensure that the mounting bracket is level.
2. Using the 4 hex head bolts (3/8"x16"x1") included with pole mount adapter (Part Number RLN6197A), secure the Gooseneck to the pole mount adapter.

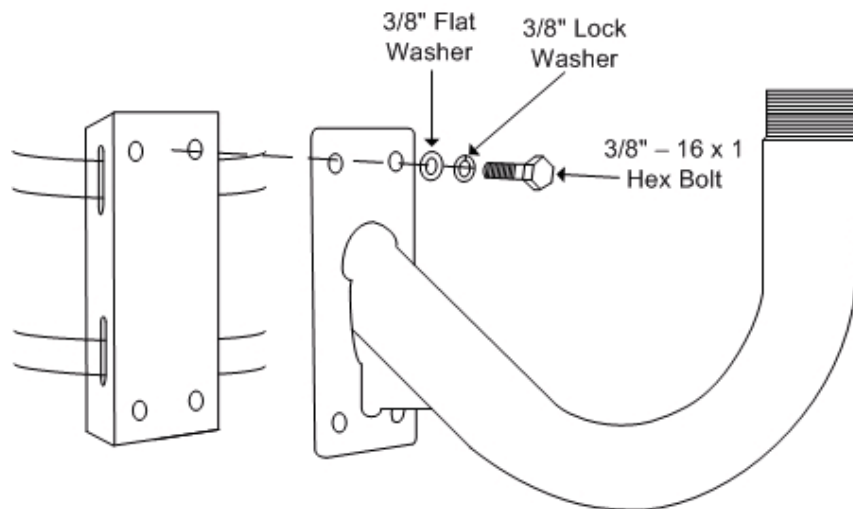



NOTE Apply lithium grease to the threads of the Gooseneck. This will help prevent corrosion from occurring and facilitate removal of the Yoke if the unit needs to be serviced.

3. Carefully remove the unit from the shipping carton.
4. Place on a solid surface with the Yoke facing up.
5. Carefully lift device and align the Yoke with the Gooseneck. In the picture below two professional installers in a bucket truck are lifting the unit onto the Gooseneck.



WARNING! An AP 7181 weighs 39 pounds. Use all appropriate cautions when lifting and consider a two man lift when necessary.

6. Attach the Yoke to the Gooseneck by rotating the device clockwise for a *minimum* of four turns. Ensure that the device is level.



7. The two set screws can now be inserted to increase stability. Tighten the set screws to between 214.2 and 250.0 inch pounds (lbf-in).



8. If the AP 7181 you are mounting is a Mesh Point Root node or a Mesh Point node with an external device (e.g. surveillance camera) perform the required Ethernet cabling.

The Ethernet cable gland is optimized for cables of diameter .39 to .55 inches. Smaller diameter cables can achieve a watertight seal if the cable gland is properly tightened during

installation. It is recommended that an Outdoor- UV Rated, shielded cable is used in AP 7181 deployments. Some examples are:

- Superior Essex 04-001-55
- Best-Tronics BT-0562

In most cases Ethernet cable will need to be custom cut to length. After preparing the Ethernet cable and attaching shielded RJ-45 end connectors feed the cable through the cable gland cap and rubber insert as shown below.



9. Insert data cable through cable gland (i.e. the cable gland on Gigabit Ethernet port GE1)
 - a. Connect the RJ45 Ethernet cable to the Ethernet port.
 - b. Hand tighten the cap for the cable gland.



- c. Using an adjustable wrench, tighten the cable grip until it fits snugly around the Ethernet cable.



- d. Repeat the process for additional Ethernet connections if required.



CAUTION Observe the following precautions to avoid damage to the unit during installation.

- Only trained and qualified personnel should install this equipment.
- Only a licensed electrician should install power cable / energize circuits.
- All device wiring must follow the National Electric Code (NEC) or wiring requirements in the country of installation. All location building and structure codes must be observed.
- Ensure that the power source for the AP 7181 is de-energized prior to installation.



WARNING! Observe the following safety precautions to avoid personal injury during installation.

- Avoid exposure to high voltage power sources.
- Avoid contact with overhead power lines.
- Avoid falling tools or equipment.
- Be aware of vehicular traffic in the vicinity of the work area.

The power cable included with the AP 7181 is a flying lead cable. Most installations will require the installer to install an additional power cable.

The AP 7181 flying lead power cables are 12 feet long. The installer should splice the power cable to the AP 7181 flying lead cable in accordance to the National Electric Code (NEC) or wiring requirements in the country of operation. Only outdoor rated power cable should be used.



CAUTION AC versions of the AP 7181 require an input voltage of 100 - 240 VAC. DC versions require an input voltage of 41-58 VDC.

10. Once the power cable has been prepared, connect the power cable to the unit.



11. The unit **must** be grounded according to the *Motorola R56 2005 Manual for Standards and Guidelines for Communication Sites*. The grounding screw is shown below in green.

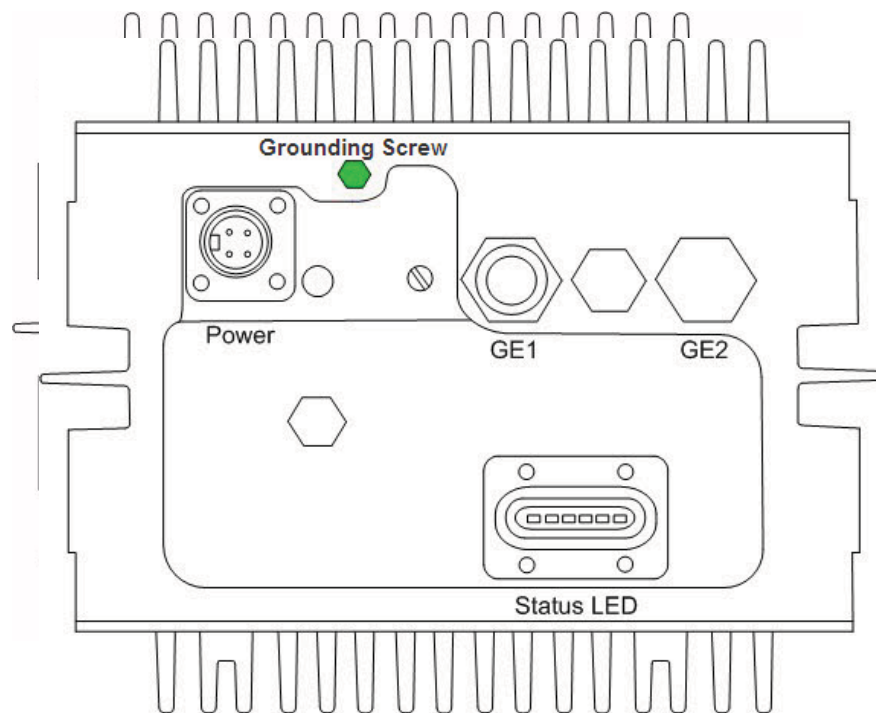

12. Secure and conceal the cables using UV resistant tie wraps. Tie wraps should be used to secure the cables along the Gooseneck.



13. If desired, attach the sun shields to the top/bottom using the captive screws. If attaching the sun shields to the bottom of the unit, first remove the knock out discs in the center to fit around the Yoke. Tighten the captive screws to between 39.9 and 53.1 inch pounds (lbf-in).

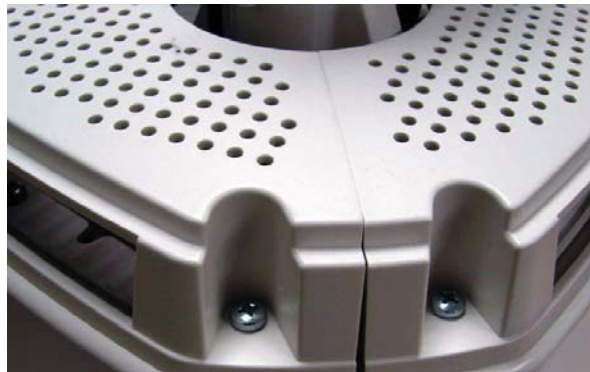

14. Once physical installation is completed the circuit powering the AP 7181 can be energized. Verify that the green power LED is lit and the unit is powered on.

2.12.2 Top Mount Installation

1. Carefully remove the unit from the shipping carton.
2. Place on a solid surface with the Yoke facing up.
3. Remove the Yoke and the Allen socket head screws from the bottom of the unit.



The pole mount adapter (Part Number RLN6197A) will accommodate a banding strap up to 1¼ inch width. Banding straps and the banding tool are not included when ordering the pole mount adapter.



The pole mount adapter can be mounted to poles from 3 inches to 15 inches in diameter and has a load rating of 75 lbs.

4. Attach the pole mount adapter (or other mounting bracket hardware) to the mounting asset and ensure that the mounting bracket is level.
5. Using the 4 hex head bolts (3/8"x16"x1") included with pole mount adapter (Part Number RLN6197A), secure the Gooseneck to the pole mount adapter.

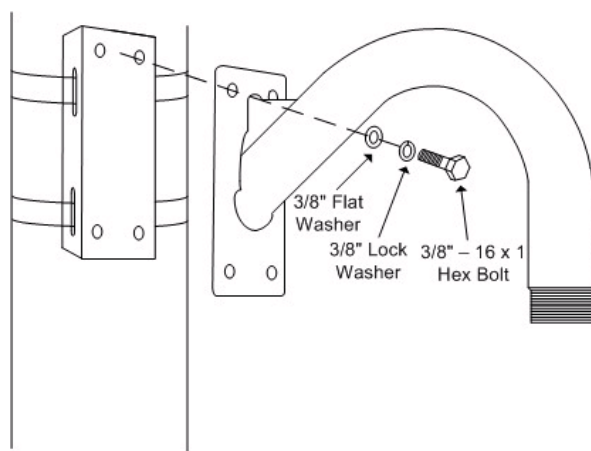

NOTE Apply lithium grease to the threads of the Gooseneck. This will help prevent corrosion from occurring and facilitate removal of the Yoke if the unit needs to be serviced.

6. Attach the Yoke to the Gooseneck by rotating the device counter clockwise for a *minimum* of four turns.

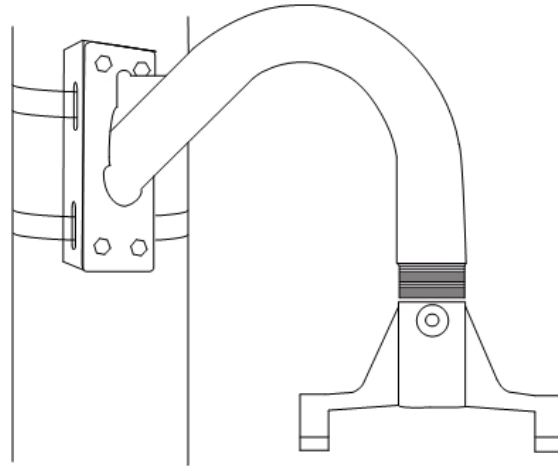

WARNING! Carefully align the Yoke with the Mounting Bracket to avoid cross threading.

7. Ensure that the Yoke and the Mounting Bracket are level.
8. Loosely attach the Allen socket head screws to the top of the unit. Leave the screws loose enough to attach the Yoke.



WARNING! An AP 7181 weighs 39 pounds. Use all appropriate cautions when lifting and consider a two man lift when necessary.

- Carefully lift the unit into position, aligning the key slots for the Yoke with the Allen socket head screws and slide the Yoke to the final position.

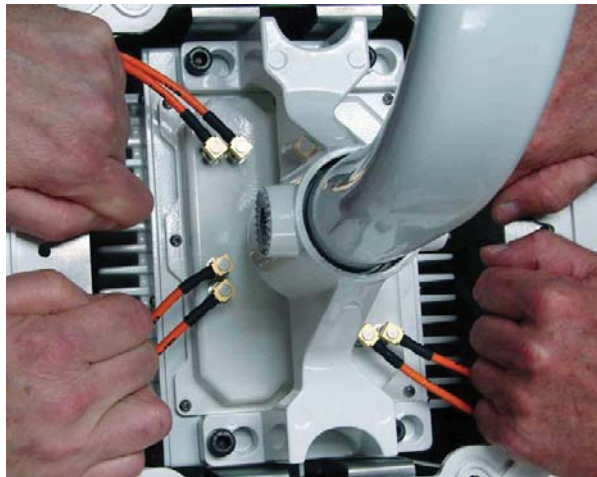

CAUTION Ensure that the Allen socket hex screws are tight and in the locked position before releasing the full weight of the unit.

- Torque the Allen socket head screws to between 108.7 and 145.0 Inch Pounds (lbf-in).
- The Set Screws can now be inserted to increase stability. Using a 21mm socket with torque wrench, tighten the Set Screws to between 214.2 and 250.0 Inch Pounds (lbf-in).



12. If the AP 7181 you are mounting is a Mesh Point Root node or a Mesh Point node with an external device (e.g. surveillance camera) perform the required Ethernet cabling.

The Ethernet cable gland is optimized for cables of diameter .39 to .55 inches. Smaller diameter cables can achieve a watertight seal if the cable gland is properly tightened during installation. It is recommended that an Outdoor- UV Rated, shielded cable is used in AP 7181 deployments. Some examples are:

- Superior Essex 04-001-55
- Best-Tronics BT-0562

In most cases Ethernet cable will need to be custom cut to length. After preparing the Ethernet cable and attaching shielded RJ-45 end connectors feed the cable through the cable gland cap and rubber insert as shown below.



13. Insert the data cable through cable gland (i.e. the cable gland on Gigabit Ethernet port GE1)
 - a. Connect the RJ45 Ethernet cable to the Ethernet port.
 - b. Hand tighten the cap for the cable gland.



- c. Using an adjustable wrench, tighten the cable grip until it fits snugly around the Ethernet cable.



- d. Repeat the process for additional Ethernet connections if required.



CAUTION Observe the following precautions to avoid damage to the unit during installation.

- Only trained and qualified personnel should install this equipment.
- Only a licensed electrician should install power cable / energize circuits.
- All device wiring must follow the National Electric Code (NEC) or wiring requirements in the country of installation. All location building and structure codes must be observed.
- Ensure that the power source for the AP 7181 is de-energized prior to installation.



WARNING! Observe the following safety precautions to avoid personal injury during installation.

- Avoid exposure to high voltage power sources.
- Avoid contact with overhead power lines.
- Avoid falling tools or equipment.
- Be aware of vehicular traffic in the vicinity of the work area.

The power cable included with the AP 7181 is a flying lead cable. Most installations will require the installer to install an additional power cable.

The AP 7181 flying lead power cables are 12 feet long. The installer should splice the power cable to the AP 7181 flying lead cable in accordance to the National Electric Code (NEC) or wiring requirements in the country of operation. Only outdoor rated power cable should be used.



CAUTION AC versions of the AP 7181 require an input voltage of 100-240 VAC. DC versions require an input voltage of 41-58 VDC.

14. Once the power cable has been prepared, connect the power cable to the unit.



15. The unit **must** be grounded according to the *Motorola R56 2005 Manual for Standards and Guidelines for Communication Sites*. The grounding screw is shown below in green.

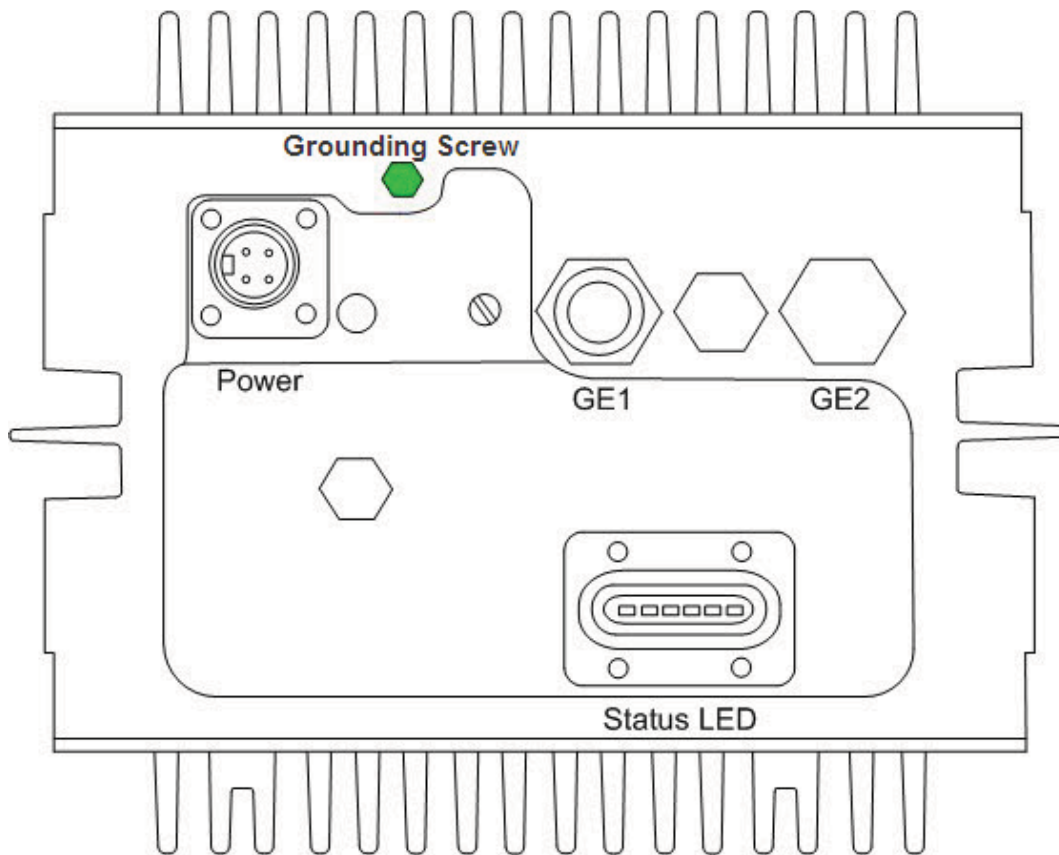

16. Secure and conceal the cables using UV resistant tie wraps. Tie wraps should also be used to secure the cables along the Gooseneck.
17. If desired, attach the sun shields to the top/bottom using the captive screws. If attaching the sun shields to the bottom of the unit, first remove the knock out discs in the center to fit around the Yoke. Tighten the captive screws to between 39.9 and 53.1 inch pounds (lbf-in).

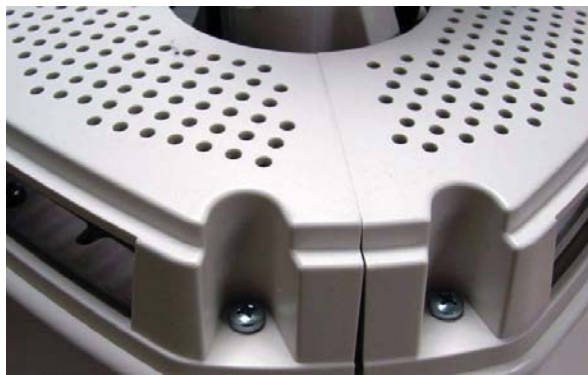

Once physical installation is completed the circuit powering the AP 7181 can be energized. Verify that the green power LED is lit and the unit is powered on.

2.13 Remote Panel Antenna Installation

When choosing a deployment location to optimize performance, it may be necessary to mount a device such that one of the antenna panels may be obstructed. For example, traffic light poles can completely obscure one of the panels in the AP 7181 antenna array. The Remote Panel antenna kit can be used to address this use case.

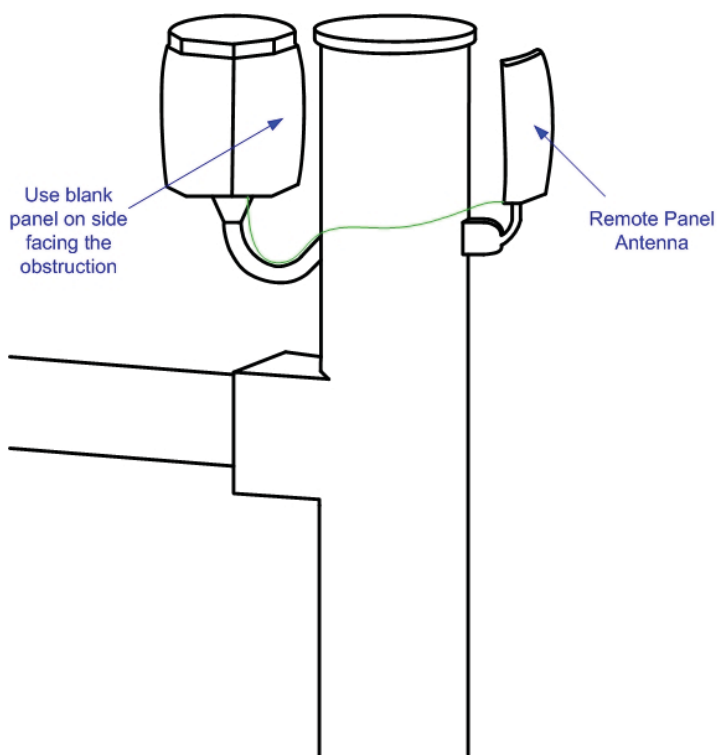

In addition to the standard hardware, the following items are also required for installing a Remote Panel antenna:

- Antenna Extension Cables (6 or 10 feet)
- Canopy Subscriber Module (SM) Mounting Bracket
- Terminators for the Horizontal (HP) and Vertical (VP) antenna connections on the top of the unit



NOTE In addition to the required tools , you will need a cordless drill and a 3.6 mm bit to predrill the hole for the set screw on the Canopy SM Mounting Bracket.

When the Remote Panel antenna installation is used, a Blank antenna panel should be attached to cover the side of the device facing the obstruction. Using a Blank antenna panel will help protect the interior of the AP 7181.



Blank antenna panels can also be used when a device is installed directly against a wall or the side of a building. See *Installing the Blank Antenna Panel*.



WARNING! When disconnecting the antenna cables from the unit or removing an antenna panel and replacing it with a Blank panel, terminators **MUST** be placed on the unused horizontal and vertical connectors on the top of the unit.



CAUTION It is also recommended that the antenna cable connectors and terminators on the horizontal and vertical connectors on the top of the AP 7181 be wrapped with both mastic tape and electrical tape.



2.13.1 Preparing the AP 7181

To prepare the AP 7181 for installation using the Remote Panel antenna:

1. Remove the screws for one of the four Radome antenna panels.



2. Grasp the lower part (barrel) of the antenna cable connector and carefully detach the antenna cables from the connectors on the device. Remove the Radome antenna panel.

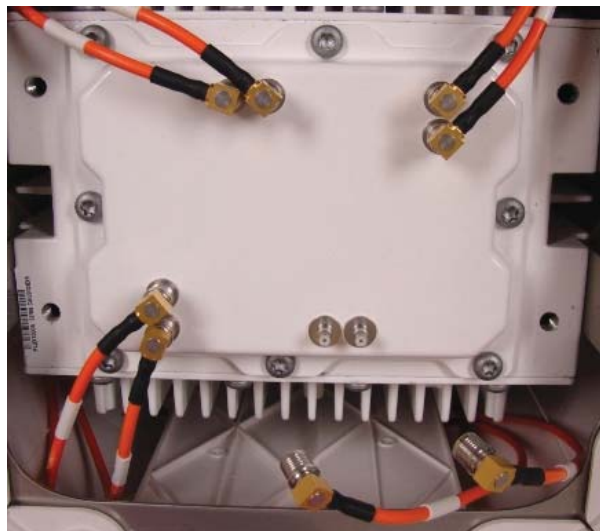

3. Attach the extension cable for the Remote Antenna panel to the device.

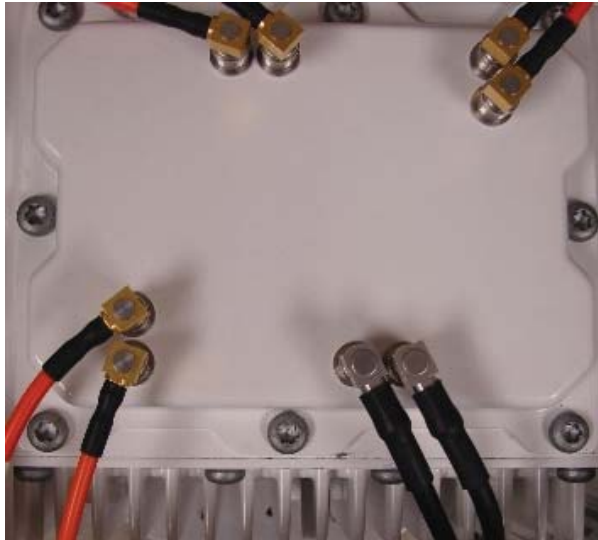

4. Carefully route the extension cable inside the antenna rings on the device.



5. Using the four screws provided, attach a Blank antenna panel to the unit to cover the side of the device where the functional antenna panel was removed.



6. Return the unit to the shipping carton for transportation to the installation site.
7. Collect the Radome panel that was removed from the unit and all other hardware and tools required for the installation.

2.13.2 Installing the Remote Panel Antenna

To complete the installation of the Remote Panel antenna at the site:

1. At the installation site, install the AP 7181 using the appropriate *Field Installation* procedure.



WARNING! DO NOT apply power to the unit until the Remote Panel installation procedure is complete.

2. Assemble the Canopy SM Mounting Bracket using the instruction sheet supplied with the hardware.
3. Test fit the Canopy SM Mounting Bracket at the installation site, positioning the bracket so that when the Remote Panel antenna is attached, it will be oriented to support line-of-sight communication with other devices.

4. Tighten the nuts on the mounting bracket so that the support arm remains in the desired position.
5. Use a cordless drill and a 3.6 mm bit to drill the hole for the set screw on the mounting bracket.
6. Insert and tighten the M4.8 set screw for the mounting bracket.



7. Using the supplied clamps, attach the Remote Antenna panel to the mounting bracket.





CAUTION When adjusting the Remote Mount antenna panel on the mounting bracket, ensure that the mounting bracket does not extend past the top of the antenna panel to comply with wind loading requirements.

8. Complete the installation of the mounting bracket using the appropriate method for the installation requirements.
9. Attach the extension cable from the AP 7181 to the connectors on the Remote Mount antenna panel and wrap the connections with Mastic tape and Electrical tape.



NOTE Both 6 and 10 foot extension cables are available. The extension cables can be configured in a daisy chain if additional length is required.

10. Secure the cables to the mounting bracket using UV resistant tie wraps.



11. After the Remote Panel installation is complete, apply power to the AP 7181



2.13.3 Installing the Blank Antenna Panel

In addition to Remote Panel antenna installations, Blank antenna panels can also be used if the unit is going to be placed directly against a wall or building. The Radome antenna should be removed and the Blank panel should be attached to side of the unit that will be facing any obstruction.



WARNING! When disconnecting the antenna cables from the unit or removing an antenna panel and replacing it with a Blank panel, terminators **MUST** be placed on the unused horizontal and vertical connectors on the top of the unit.



CAUTION It is also recommended that the antenna cable connectors and terminators on the horizontal and vertical connectors on the top of the AP 7181 be wrapped with both mastic tape and electrical tape.



To install a Blank antenna panel:

1. Remove the screws for one of the four Radome antenna panels.



2. Grasp the lower part (barrel) of the antenna cable connector and carefully detach the antenna cables from the connectors on the device. Remove the Radome antenna panel.



3. Attach the terminators to the antenna cable connectors.



4. Wrap the terminators with mastic tape and electrical tape.



5. Using the four screws provided, attach a Blank antenna panel to the unit to cover the side of the device where the functional antenna panel was removed.

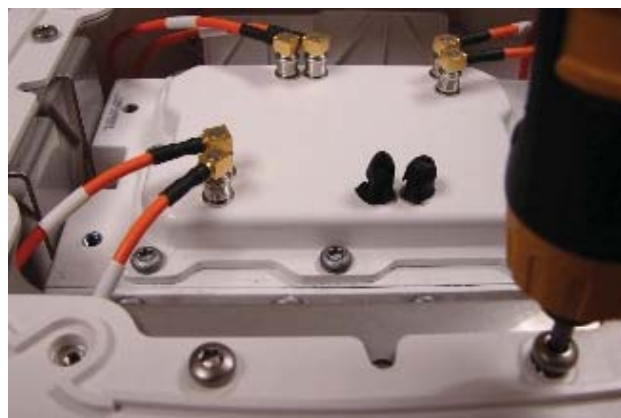

3 Getting Started

Use the following procedures to configure and setup up the AP 7181.

3.1 Initially Connecting to the Access Point

The AP 7181 can be staged and configured using one of several connection techniques. Managing the access point includes viewing network statistics and setting configuration options. The access point requires one of the following connection methods to manage the network:

- Secure Java-Based WEB UI - (use Sun Microsystems JRE 1.5 or higher available from Sun's Web site. Disable Microsoft's Java Virtual Machine if installed). For information on using the Web UI to set access point default configuration, refer to *Basic Device Configuration* or chapters 4 through 7 of the *AP 7181 Access Point Product Reference Guide*.
- Command Line Interface (CLI) via Serial, Telnet and SSH. The access point CLI is accessed through the RS232 port, via Telnet or SSH. The CLI follows the same configuration conventions as the device user interface with a few documented exceptions. For details on using the CLI to manage the access point, refer to chapter 8 of the *AP 7181 Access Point Product Reference Guide*.
- Config file - Readable text file; Importable/Exportable via FTP, TFTP and HTTP. Configuration settings for an access point can be downloaded from the current configuration of another access point meeting the import/export requirements.

3.1.1 Connecting to the Access Point Using the WAN Port



NOTE These procedures are only valid for initially connecting to an AP 7181.

To initially connect to the access point using the access point's WAN port:

1. Connect AC power to the access point.
2. The WAN (or GE2) port default is configured with an IP address of 10.1.1.1. Configure a laptop with an IP address of 10.1.1.2 / 255.0.0.0 and connect to the GE2 port.
3. Launch a browser and enter the access point's static IP address (10.1.1.1). The default password is "motorola".

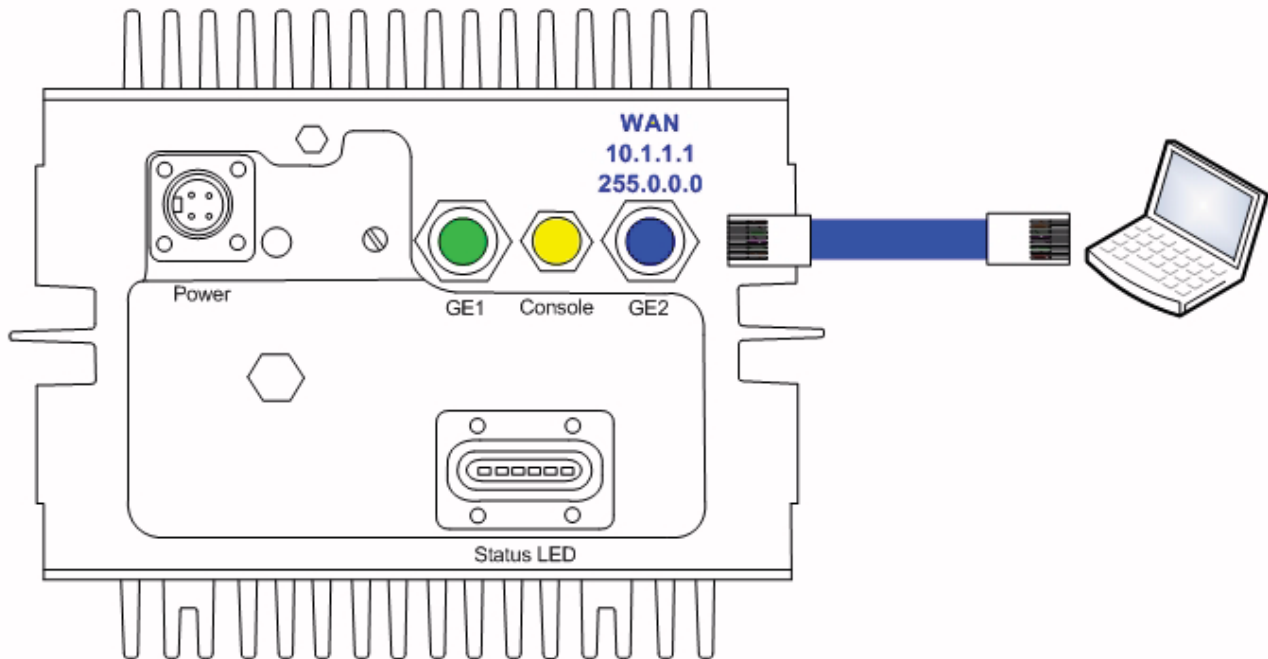

3.1.2 Connecting to the Access Point Using the LAN Port

To initially connect to the access point using the access point's LAN port:

1. The LAN (or GE1/POE) port default is set to DHCP. Connect the access point's GE1/POE port to an Ethernet segment with access to a DHCP server. The access point will automatically receive an IP address.
2. To view the IP address, connect one end of a null modem serial cable to the access point and the other end to the serial port of a computer running HyperTerminal or similar emulation program
 - Configure the following settings:
 - Baud Rate - 115200
 - Data Bits - 8
 - Stop Bits - 1
 - No Parity
 - No Flow Control
3. Press <ESC> or <Enter> to access the access point CLI.
4. Enter the default username of "admin" and the default password of "motorola."
5. Since this is the first time you are logging into the access point, you will be prompted to enter a new password and set the county code.



NOTE AP 7181 units configured for deployment in the US will not prompt the user for a country code.

6. At the CLI prompt (admin>), type "summary."
7. The access point's LAN IP address will be displayed.
8. Connect a laptop on the same Ethernet segment as the access point (e.g. set the laptop for DHCP so it receives an IP address from the same DHCP server)

- Using a Web browser, use the access point's IP address to access the access point.

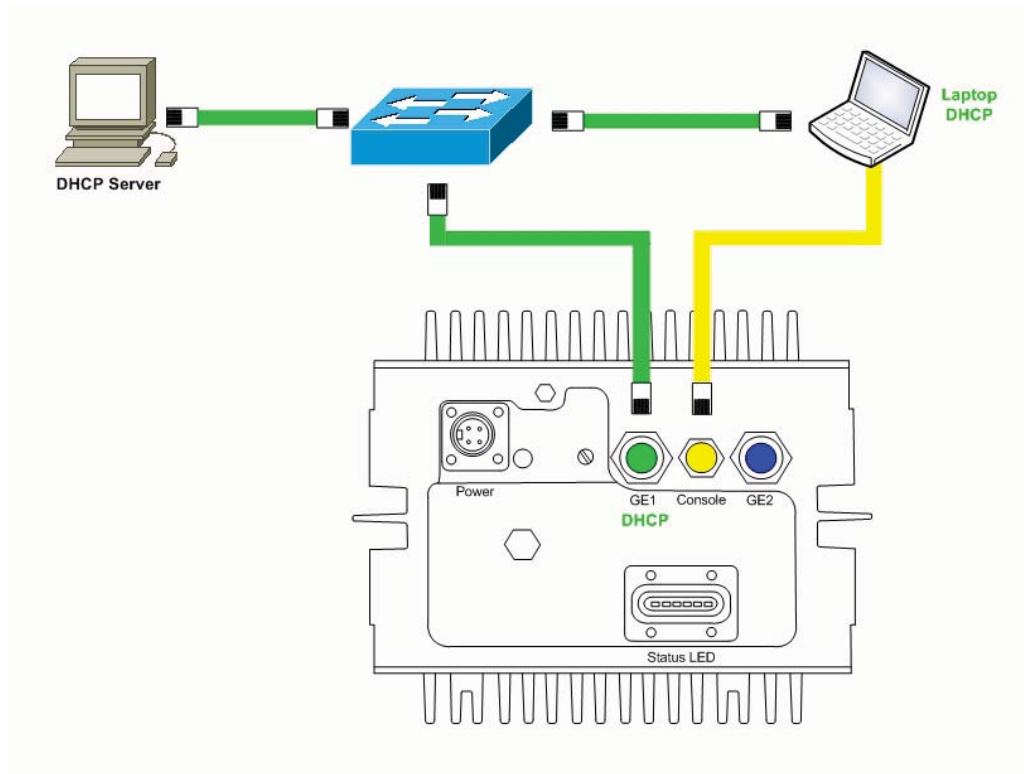

3.2 Basic Device Configuration

For the basic setup described in this section, the Java-based Web UI will be used to configure the access point. Use the access point's LAN interface for establishing a link with the access point. Configure the access point as a DHCP client. For optimal screen resolution, set your screen resolution to 1024 x 768 pixels or greater.

1. Open a browser. If you used the WAN method, point your browser to 10.1.1.1. If you used the LAN method, point your browser to the IP address provided by the DHCP server.



NOTE For optimum compatibility, use Java Runtime Environment 1.5 or higher and disable the Microsoft Java Virtual Machine.



2. Log in using admin as the default Username and motorola as the default Password. Use your new password if it has been updated from default.
3. If the default login is successful, the Change Admin Password window displays. Change the password.



Enter the current password and a new admin password in fields provided. Click Apply. Once the admin password has been updated, a warning message displays stating the access point must be set to a country.

The export function will always export the encrypted Admin User password. The import function will import the Admin Password only if the access point is set to factory default. If the access point is not configured to factory default settings, the Admin User password WILL NOT be imported.



NOTE For optimum compatibility, use Java Runtime Environment 1.5 or higher and disable the Microsoft Java Virtual Machine.

3.2.1 Configuring Device Settings

Many of the most important parameter settings located on the configuration pages throughout the menu tree have been consolidated on the Quick Setup screen to facilitate getting the unit up and running quickly. Configure a set of minimum required device settings within the Quick Setup screen. When you change the settings in the Quick Setup screen, the values also change for other screens where these parameters are displayed. Additionally, if the values are updated in these other screens, the values initially set within the Quick Setup screen will be updated.

Basic Settings

To define a basic access point configuration:

1. If the Quick Setup screen is not already displayed, select **System Configuration > Quick Setup** from the menu tree.
2. Enter a **System Name** for the access point.

The screenshot displays the configuration interface for an AP-7181 Access Point. The main window is titled "AP-7181 Access Point" and "AP-71XX Quick Setup". On the left is a navigation menu with options like [Network Configuration], [System Configuration], Quick Setup, System Settings, Geographic Settings, Adaptive AP Setup, AP-71XX Access, [Certificate Mgmt], [User Authentication], SNMP Access, Date/Time, Logging Configuration, Config Import/Export, Firmware Update, and [Status & Statistics].

The main configuration area is divided into several sections:

- AP-71XX System Settings:**
 - System Name: AP-7181-3
 - Country: United States - us
 - Time Server: 0 . 0 . 0 . 0
- Radio Configuration:**
 - Enable RF band of operation:
 - 802.11b/g/n (2.4 GHz)
 - 802.11a/n (5 GHz)
- WAN Interface (LAN#1 selected):**
 - Enable WAN interface
 - This interface is a DHCP Client
 - IP Address: 10 . 1 . 1 . 1
 - Subnet Mask: 255 . 0 . 0 . 0
 - Default Gateway: 0 . 0 . 0 . 0
 - Primary DNS Server: 0 . 0 . 0 . 0
 - Enable PPP over Ethernet
 - Keep Alive
 - Username: []
 - Password: []
- WLAN #1 Configuration:**
 - ESSID: 101
 - Name: WLAN1
 - Available On:
 - 802.11 b/g/n (2.4 GHz)
 - 802.11 a/n (5.0 GHz)
 - Security Policy: Default [Create]

At the bottom of the interface, there are buttons for "Apply", "Undo Changes", "Help", and "Logout". A status bar at the very bottom shows "System Name AP-7181-3".

The System Name is useful if multiple devices are being administered.

3. Optionally enter the IP address of the server used to provide system time to the access point in the Time Server field.



NOTE DNS names are not supported as a valid IP address. The user is required to enter a numerical IP address.

Once the IP address is entered, the access point's Network Time Protocol (NTP) functionality is engaged automatically. Refer to the *AP 7181 Product Reference Guide* for information on defining alternate time servers and setting a synchronization interval for the access point to adjust its displayed time and more detailed information on setting alternate time servers and setting a synchronization interval for the access point to adjust its displayed time.

4. Enable the radio(s) using the **Enable** checkbox(es) in the Radio Configuration field. If using a single radio access point, enable the radio then select either 2.4 GHz or 5.x GHz from the **RF Band of Operation** field.

IP Settings

The LAN 1 interface on the AP 7181 supports several different functions. The IP address assigned to the LAN (by DHCP or via a static address) is the management IP address for the access point. By default, the LAN 1 interface is tied to physical port GE1 and is configured for DHCP.

Mesh Point Root nodes are gateway nodes. AP 7181 nodes that are configured as Mesh Point Roots will utilize the LAN 1 interface (GE1) to connect to the core network.

Nodes that are Non Root Mesh Points also utilize LAN 1 since the IP address of LAN 1 is the management IP address of the access point. LAN 1 is set to DHCP by default and Non Root Nodes will receive their IP address over the mesh network. Non Root nodes can also use GE1 to connect to external devices such as a surveillance camera.

To configure the IP Settings:

1. Click the **LAN** tab to set a minimum set of parameters to use the access point LAN interface.
2. Select the **Enable LAN Interface** checkbox to forward data traffic over the access point's LAN connection. The LAN connection is enabled by default.

The screenshot shows the configuration page for the LAN#1 interface. At the top, there are two tabs: 'WAN' and 'LAN#1', with 'LAN#1' being the active tab. Below the tabs, there is a checkbox labeled 'Enable LAN Interface' which is checked. Underneath, there is a label 'This interface' followed by a dropdown menu currently set to 'uses static IP Address'. Below this are several input fields for network configuration: 'IP Address' (10 . 0 . 50 . 100), 'Subnet Mask' (255 . 255 . 255 . 0), 'Default Gateway' (10 . 0 . 50 . 1), 'Primary DNS Server' (10 . 0 . 50 . 254), and 'Address Assignment Range' (192 . 168 . 0 . 100 to 192 . 168 . 0 . 254).

3. Use the **This interface** drop-down menu to specify how network address information is defined over the access point's LAN connection. Select **DHCP Client** if the access points will receive an IP address from the core network via DHCP. DHCP is a protocol that includes mechanisms for IP address allocation and delivery of host-specific configuration parameters, such as IP address, network mask, and gateway, from a DHCP server to a host.
4. Select DHCP Server to use the access point as a DHCP server over the LAN connection. Select the Bootp client option if network addressing is provided by a Bootp server.
5. If using the static or DHCP Server option, enter the network-assigned **IP Address** of the access point.
6. The **Subnet Mask** defines the size of the subnet. The first two sets of numbers specify the network domain. The next set of numbers specifies the subset of hosts within a larger network. These values help divide a network into sub networks and simplify routing and data transmission.

7. If using the static or DHCP Server option, enter a **Default Gateway** to define the numerical IP address of a router the access point uses as a default gateway on the Ethernet.
8. If using the static or DHCP Server option, enter the **Primary DNS Server** numeric IP address.
9. If using the DHCP Server option, use the **Address Assignment Range** parameter to specify a range of addresses to be reserved for mapping clients to IP addresses.



NOTE If a manually (static) mapped IP address is within the IP address range specified, that IP address could still be assigned to another client. To avoid this, ensure all statically mapped IP addresses are outside of the IP address range assigned to the DHCP server.

WLAN Quick Configuration

The Quick Setup page includes a WLAN section to support WLAN creation. By default, a single WLAN is configured as *ESSID 101, Open, Available on both radios*.

1. WLANs 1-4 are available on the Quick Setup screen. Select the **WLAN #1** tab to define its ESSID and security scheme for basic operation.
 - a. Enter the **Extended Services Set Identification (ESSID)** and the name associated with the WLAN. This name will be identified by 802.11 stations when searching for a network to connect to.
 - b. Use the **Available On** checkboxes to define whether the target WLAN is operating in the 2.4 or 5.x GHz radio band. Ensure the radio selected has been enabled.
2. Once the WLAN's radio designations have been made, the radio must be configured in respect to intended 2.4 or 5 GHz radio traffic and the antennas used. Select **Network Configuration -> Wireless -> Radio Configuration -> Radio1** (or Radio2), and configure the Radio Settings field. If you know the Properties, Performance and Beacon Settings for the radio, define those fields. Otherwise you can accept the factory default settings.
3. Define the Channel Settings, Power Level and 802.11 mode with respect to the 2.4 or 5.x GHz 802.11b/g/n or 802.11a/n radio traffic and anticipated gain of the antennas.



CAUTION Only a qualified wireless network administrator should set the access point radio configuration. Refer to *Configuring the 802.11a/n or 802.11b/g/n Radio* in the *AP 7181 Product Reference Guide* for an understanding of configurable radio values and their implications..



NOTE Even an access point with a minimal configuration must be protected against data theft and corruption. A security policy should be configured for WLAN1 as part of the basic configuration outlined in this guide. A security policy can be configured for the WLAN using the Quick Setup screen. Policies can be defined over time and saved to be used as needed as security requirements change. Motorola recommends that you familiarize yourself with the security options available on the access point before defining a security policy. Refer to *Configuring WLAN Security Settings*.

4. Click **Apply** to save any changes to the access point Quick Setup screen. Dismissing the screen without clicking Apply results in all changes to the screens being lost.
5. Click **Undo Changes** to delete any changes made in error. Undo Changes reverts the settings displayed on the access point Quick Setup screen to the last saved configuration.

Removing the WAN Interface from GE2

By default, the WAN interface is enabled and has a static IP address of 10.1.1.1/8. This interface is tied to physical port GE2 and is used for initial configuration.

In order to use GE2 to connect external devices such as an IP surveillance camera, you will need to configure the port from a WAN role to a LAN role. This is done by clicking on the WAN branch under Network Configuration and selecting LAN in the drop down box for GE2. This will bridge the GE1 and GE2 ports. Any device plugged into GE2 will then be on the same LAN segment as GE1.

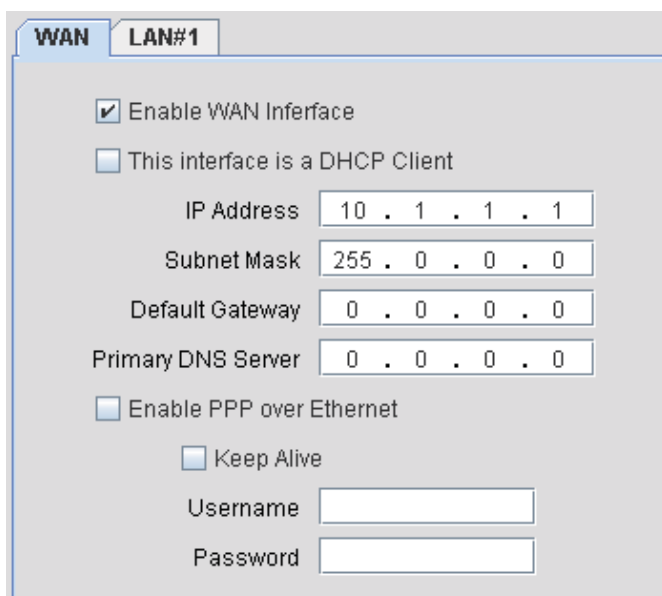

The screenshot shows a configuration window with two tabs: 'WAN' (selected) and 'LAN#1'. The 'WAN' tab contains the following settings:

- Enable WAN Interface
- This interface is a DHCP Client
- IP Address: 10 . 1 . 1 . 1
- Subnet Mask: 255 . 0 . 0 . 0
- Default Gateway: 0 . 0 . 0 . 0
- Primary DNS Server: 0 . 0 . 0 . 0
- Enable PPP over Ethernet
 - Keep Alive
 - Username:
 - Password:

To remove the WAN interface from GE2:

1. Select **Network Configuration -> WAN** from the menu tree.
2. In the **Role** drop-down box, select LAN.

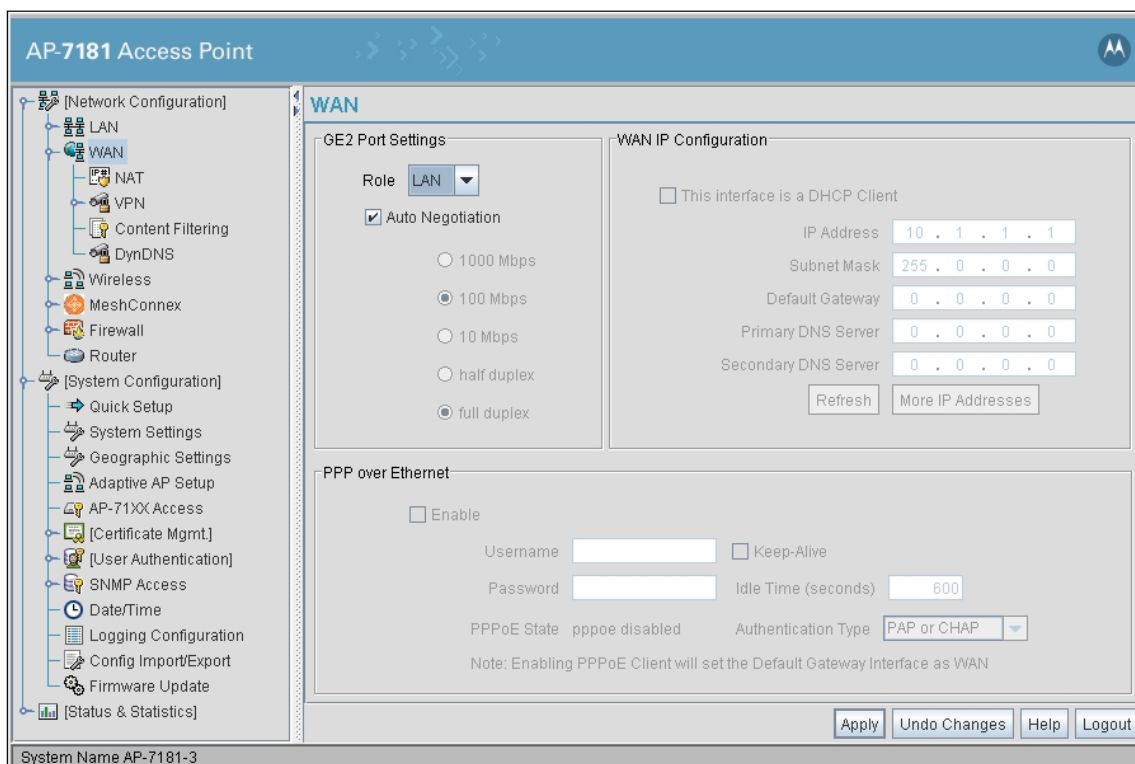

For more information on WAN port configuration options, refer to Configuring WAN Settings in the *AP 7181 Access Point Product Reference Guide*.

The following diagram illustrates the configuration changes that result from setting the Role parameter to LAN.

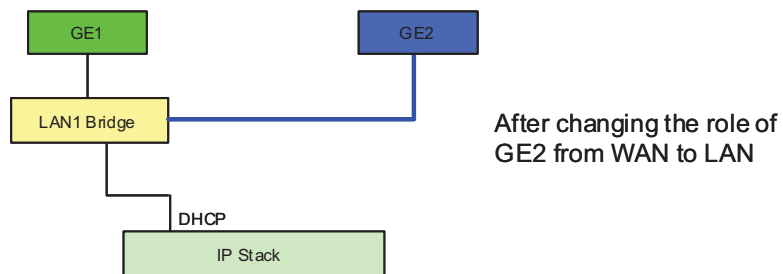
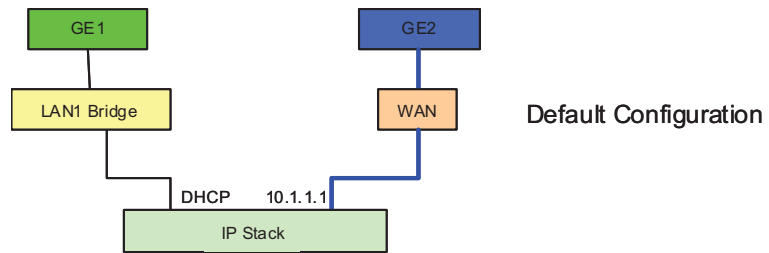

3.2.2 Configuring WLAN Security Settings

By default the AP 7181 has a default security policy of No Security. In the following example a WPA2/CCMP security policy will be configured that can be applied to newly created WLANs.

To configure a basic security policy for a WLAN:



NOTE Even an access point with minimal configuration values must be protected against data theft and corruption. A security policy should be configured for WLAN1 as part of the basic configuration outlined in this guide. A security policy can be configured for the WLAN from within the Quick Setup screen. Policies can be defined over time and saved to be used as needed as security requirements change. Motorola recommends you familiarize yourself with the security options available on the access point before defining a security policy.

1. From the access point **Quick Setup** screen, click the **Create** button to the right of the Security Policy item.
2. Ensure the Name of the security policy entered suits the intended configuration or function of the policy.



CAUTION Multiple WLANs can share the same security policy. Avoid naming security policies after specific WLANs to eliminate the risk of limiting a WLAN to single policy. Motorola recommends naming the policy after the attributes of the authentication or encryption type selected.

3. Select the **WPA2/CCMP (802.11i)** radio button. The **WPA2/CCMP Settings** field is displayed within the New Security Policy screen.

The screenshot shows the 'New Security Policy' configuration window. The 'Name' field is set to 'WPA2/CCMP'. Under the 'Authentication' section, the 'Manually Pre-shared key / No authentication' radio button is selected. Under the 'Encryption' section, the 'WPA2/CCMP (802.11i)' radio button is selected. The 'WPA2/CCMP Settings' section is expanded, showing the 'Encryption' tab. In the 'Key Rotation Settings', the 'Broadcast Key Rotation' checkbox is unchecked, and the 'Update broadcast keys every' field is set to '86400' seconds. In the 'Key Settings' section, the 'ASCII Passphrase' radio button is selected, and the passphrase 'motorola' is entered in the text box. Below it, the '256-bit Key' radio button is selected, and four text boxes contain the hex keys: '1011121314151617', '18191A1B1C1D1E1F', '2021222324252627', and '28292A2B2C2D2E2F'. In the 'WPA2-CCMP Mixed Mode' section, the 'Allow WPA/WPA2-TKIP clients' checkbox is checked. In the 'Fast Roaming (802.11x only)' section, the 'Pre-Authentication' checkbox is unchecked. At the bottom right, there are 'Apply', 'Cancel', and 'Help' buttons.

4. Configure the **WPA2/CCMP Settings** fields as required to define the Pass Key used to generate the WEP keys.

Key Settings Click the ASCII Passphrase box and enter a passphrase 8 to 63 characters long.

Mixed Mode Under WPA2-CCMP Mixed Mode select the Allow WPA/WPA2-TKIP clients checkbox to enable support for TKIP and AES encryption.

5. Click the **Apply** button to save the security policy and return to the access point Quick Setup screen.

You can now test the access point for MU (801.11 station) interoperability.

3.2.3 Creating a Secure Recovery WLAN

When staging an AP 7181, it is recommended to create a security recovery WLAN to be used in case the unit becomes unreachable due to errors in configuration or fluctuating conditions which affect transmission across the wireless network. This is particularly important if your AP 7181 is addressed via DHCP as the IP address would be lost if a node became stranded. If the AP 7181 is statically addressed you can connect any configured WLAN mapped to LAN 1.

1. Click the Enable button next to LAN2 in the LAN branch under Network Configuration.

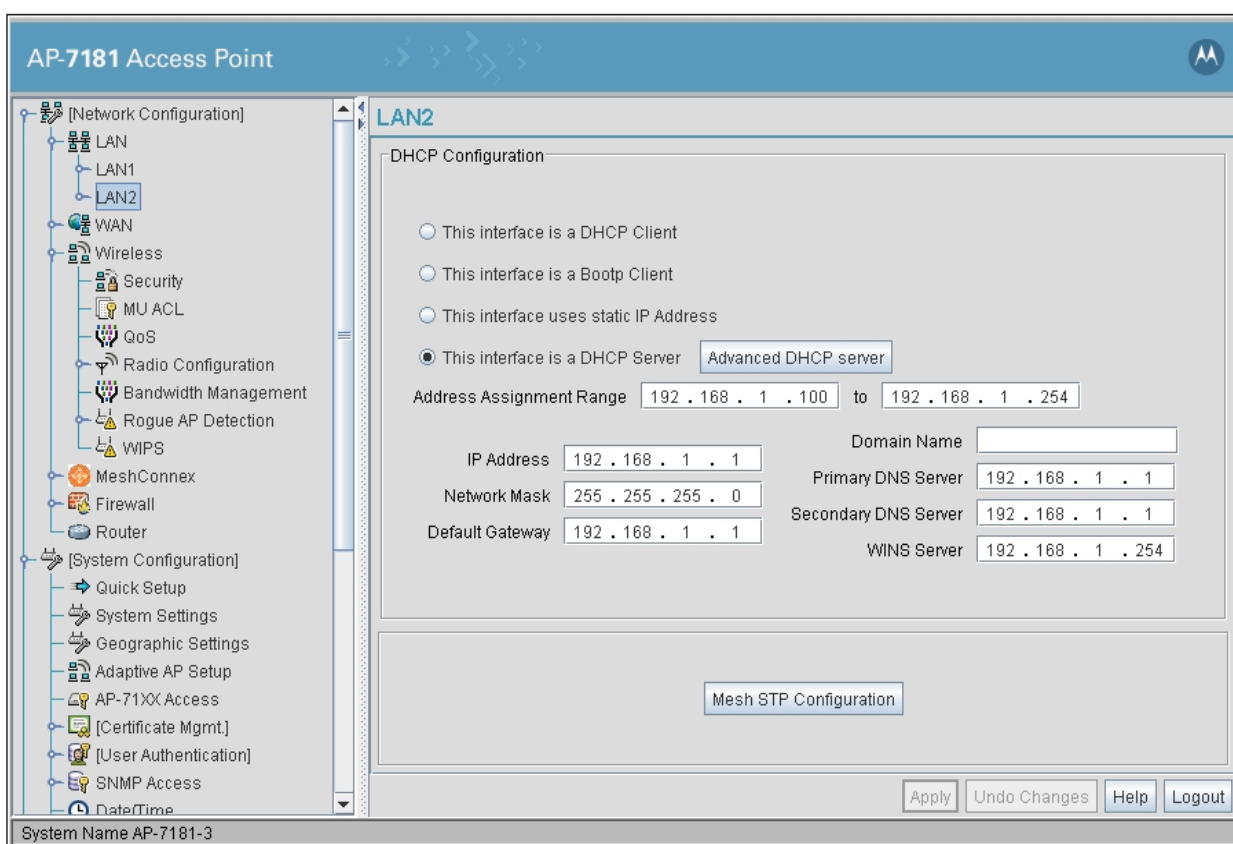

After enabling LAN2 you will see an entry for LAN2 under the LAN branch. Select **LAN2**. Notice that LAN2 is configured with an IP address of 192.168.1.1 255.255.255.0 by default and is also a DHCP server.

- Determine what ESSID (or network name) to use. It is recommended that a unique ESSID be used for each AP 7181. Since the recovery WLAN is going to be on the 2.4 GHz radio, we chose to use the MAC address of the 2.4 GHz radio. This can be found by selecting Radio1 [802.11b/g/n] located under **Network Configuration - Wireless - Radio Configuration**. The radio MAC address is located in the properties window. Record this MAC address.

The screenshot displays the configuration interface for an AP-7181 Access Point. The left sidebar shows a tree view of configuration categories, with 'Radio Configuration' selected and 'Radio1[802.11b/g/n]' highlighted. The main panel shows the 'Radio1[802.11b/g/n] Settings' window, which is divided into several sections:

- Properties:**
 - Placement: Outdoor
 - MAC Address: 00:23:68:10:FE:F0
 - Radio Type: 802.11n (2.4 GHz)
 - ERP Protection: Off
 - HT Protection: non-HT STA on Channel
- Performance:**
 - Support Short Preamble:
 - RTS Threshold: 2347 Bytes
 - Buttons: Set RF QoS, Set Aggregation
- Beacon Settings:**
 - Beacon Interval: 100 K-usec
 - DTIM Interval: 10 Beacon Interval(s)
- Channel, power and Rates Settings:**
 - 802.11 b/g/n mode: B, G and N (Set Rates button)
 - Channel Width: 20 MHz
 - Channel Selection: Automatic (Scan button)
 - Channel Scan List: ...
 - Primary Channel: []
 - Secondary Channel: []
 - Desired Power Level: 30 dBm (1000 mW)
 - Current Power Level: 19.0
- QBSS Load Element Settings:**
 - Enable QBSS load element:
 - QBSS Beacon Interval: 10 Beacon Time
- ADEPT Antenna Settings:**
 - Enable Down-tilt:

At the bottom of the window, there are buttons for 'Apply', 'Undo Changes', 'Help', and 'Logout'. The system name 'AP-7181-3' is visible at the bottom left.

3. Create a non-broadcasting secure WLAN. Select **Network Configuration -> Wireless** . Click **Create**.

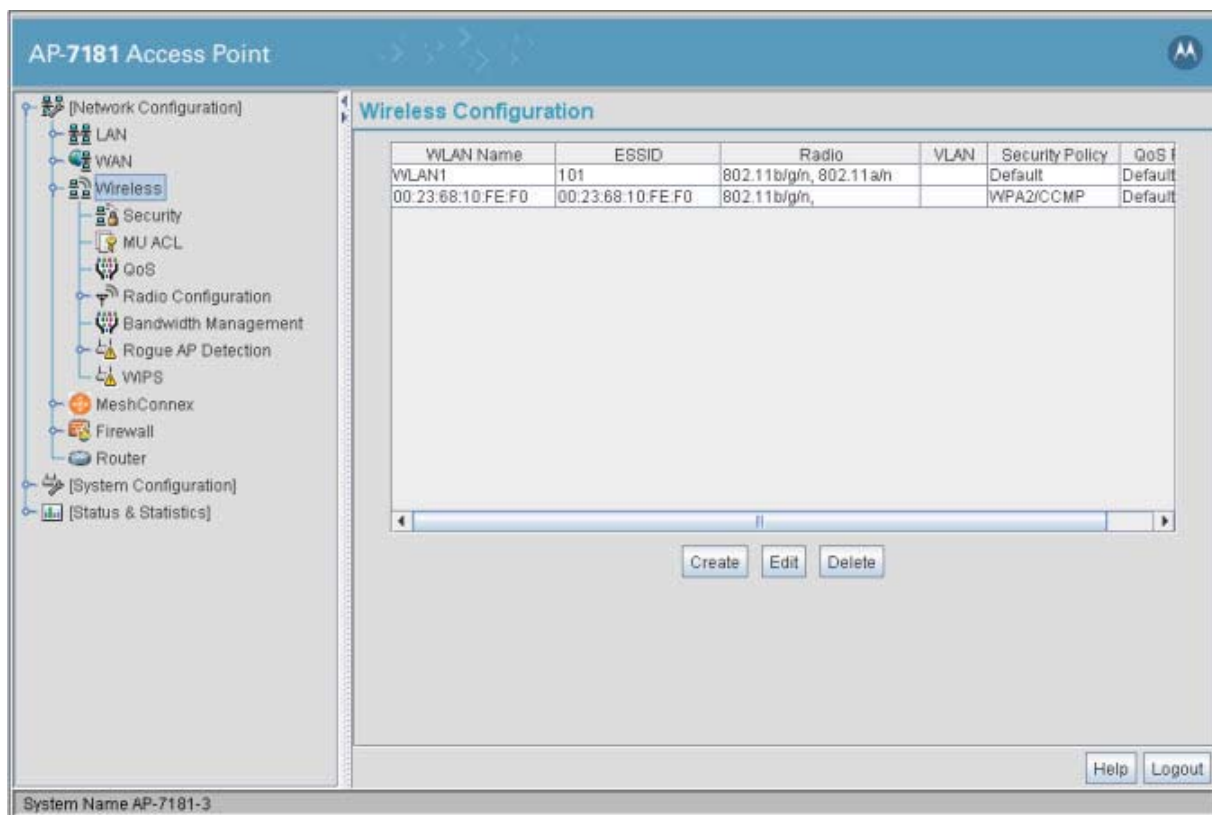

The screenshot shows the configuration interface for an AP-7181 Access Point. The left sidebar contains a tree view of configuration categories: [Network Configuration], LAN, WAN, Wireless, Security, MU ACL, QoS, Radio Configuration, Bandwidth Management, Rogue AP Detection, WIPS, MeshConnex, Firewall, Router, [System Configuration], and [Status & Statistics]. The main area is titled "Wireless Configuration" and contains a table with the following data:

WLAN Name	ESSID	Radio	VLAN	Security Policy	QoS
WLAN1	101	802.11b/g/n, 802.11a/n		Default	Default
00:23:68:10:FE:F0	00:23:68:10:FE:F0	802.11b/g/n,		WPA2/CCMP	Default

Below the table are three buttons: Create, Edit, and Delete. At the bottom right of the interface are buttons for Help and Logout. The system name "System Name AP-7181-3" is displayed at the bottom left.

4. Enter an ESSID. use the MAC address recorded in the previous step. Under **Available On** select the **802.11 b/g/n** checkbox.

The image shows a 'New WLAN' configuration window with the following fields and options:

- Configuration:**
 - ESSID: 00:23:68:10:FE:F0
 - Name: 00:23:68:10:FE:F0
 - Available On:
 - 802.11 a/n Radio
 - 802.11 b/g/n Radio
 - Maximum MUs: 127
 - MU Idle Timeout: 30
 - Enable Client Bridge Backhaul
 - Enable Hotspot (with 'Configure Hotspot' button)
- Security:**
 - Security Policy: WPA2/CCMP (with 'Create' button)
 - MU Access Control: Default (with 'Create' button)
 - Kerberos User Name: 00:23:68:10:FE:F0
 - Kerberos Password: (empty field)
- Advanced:**
 - Disallow MU To MU Communication
 - Use Secure Beacon
 - Accept Broadcast ESSID
 - Quality Of Service Policy: Default (with 'Create' button)

Buttons at the bottom: Apply, Cancel, Help

5. Select the Security Policy you previously created for WPA2/CCMP. Select the **Use Secure Beacon** checkbox to suppress the broadcasting of this network.
6. Click **Apply**.
7. To map the secure WLAN to LAN2, select **Network Configuration -> LAN**. Click **WLAN Mapping**.

The screenshot displays the configuration interface for an AP-7181 Access Point. The left sidebar shows a navigation tree with categories: [Network Configuration] (containing LAN, WAN, Wireless, MeshConnex, Firewall, Router) and [System Configuration] (containing [Status & Statistics]). The main content area is titled "LAN Configuration" and is divided into several sections:

- LAN Settings:** A table with columns for "Enable", "LAN Name", "GE1", "GE2", and "Enable 802.1q Trunking".

Enable	LAN Name	GE1	GE2	Enable 802.1q Trunking
<input checked="" type="checkbox"/>	LAN1	<input checked="" type="radio"/>	<input checked="" type="radio"/>	<input type="checkbox"/>
<input checked="" type="checkbox"/>	LAN2	<input type="radio"/>	<input type="radio"/>	<input type="checkbox"/>

Below this table are buttons for "VLAN Name" and "WLAN Mapping".
- LAN Ethernet Timeout:** A section with "Ethernet Port Timeout" set to a dropdown menu showing "Disabled" and a value of "30 Sec".
- 802.1x Port Authentication:** Fields for "Username" (admin) and "Password" (masked with #).
- GE1 Port Settings:** Includes a checked "Auto Negotiation" checkbox and radio buttons for speed and duplex: "1000 Mbps", "100 Mbps" (selected), "10 Mbps", "half duplex", and "full duplex" (selected).

At the bottom right of the configuration area are buttons for "Apply", "Undo Changes", "Help", and "Logout". The bottom status bar shows "System Name AP-7181-3".

8. In **LAN/VLAN/WLAN Mapping**, find the ESSID you created and use the drop-down box under **LAN** and select **LAN2**. Click **OK**.

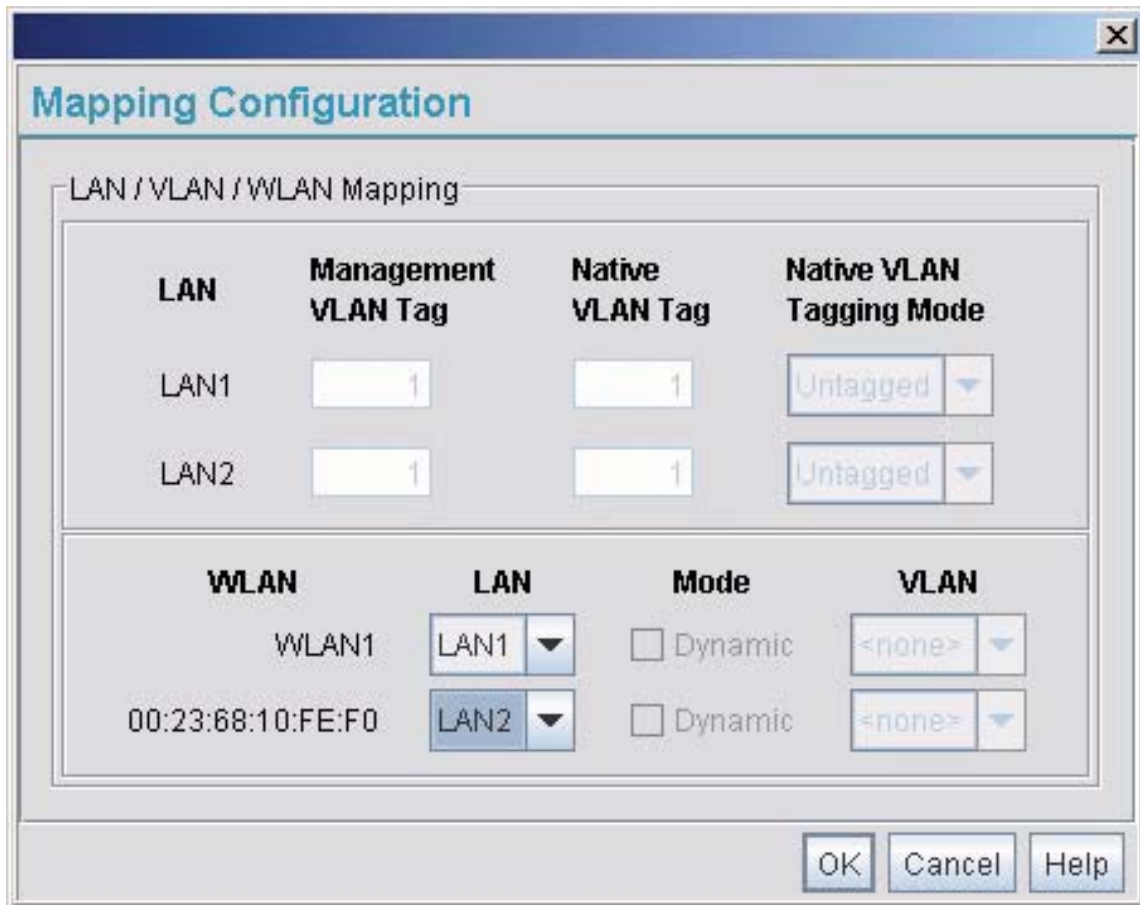

The image shows a 'Mapping Configuration' dialog box with a title bar and a close button. The main content is divided into two sections: 'LAN / VLAN / WLAN Mapping' and a lower section for WLAN configuration. The 'LAN / VLAN / WLAN Mapping' section contains a table with four columns: LAN, Management VLAN Tag, Native VLAN Tag, and Native VLAN Tagging Mode. The 'LAN' column lists LAN1 and LAN2. The 'Management VLAN Tag' and 'Native VLAN Tag' columns both have the value '1'. The 'Native VLAN Tagging Mode' column has a dropdown menu set to 'Untagged'. The lower section has four columns: WLAN, LAN, Mode, and VLAN. The 'WLAN' column lists 'WLAN1' and a MAC address '00:23:68:10:FE:F0'. The 'LAN' column has dropdown menus set to 'LAN1' and 'LAN2'. The 'Mode' column has two checkboxes labeled 'Dynamic', both of which are unchecked. The 'VLAN' column has dropdown menus set to '<none>'. At the bottom right, there are three buttons: 'OK', 'Cancel', and 'Help'.

LAN	Management VLAN Tag	Native VLAN Tag	Native VLAN Tagging Mode
LAN1	1	1	Untagged
LAN2	1	1	Untagged

WLAN	LAN	Mode	VLAN
WLAN1	LAN1	<input type="checkbox"/> Dynamic	<none>
00:23:68:10:FE:F0	LAN2	<input type="checkbox"/> Dynamic	<none>

9. The **LAN Configuration** screen will be displayed again. Click **Apply**.
10. The secure recovery WLAN is now configured. Record the ESSID for future reference.

3.2.4 Testing Connectivity

Verify the access point's link with an MU by sending ping packets to the associated MU. Use the Echo Test screen to specify a target MU and configure the parameters of the test. Connect an MU to the hidden recovery WLAN and configure its IP address for DHCP.



NOTE Before testing for connectivity, the target MU needs to be set to the same ESSID as the access point. Since WPA-PSK security has been configured on the recovery WLAN for the access point, the MU will be prompted for a passphrase after associated to the ESSID.

To test connectivity to a specific MU with an access point:

1. Select **Status and Statistics -> MU Stats** from the menu tree.
2. Click **Echo Test** on the MU Stats Summary screen.
3. Define the following parameters for the test.

<i>Station Address</i>	The station address is the IP address of the target MU. Refer to the MU Stats Summary screen for associated MU IP address information.
<i>Number of pings</i>	Defines the number of packets to be transmitted to the MU. The default is 100.
<i>Pack Length</i>	Specifies the length of each packet transmitted to the MU during the test. The default length is 100 bytes.

4. Click **Ping** to begin transmitting packets to the specified MU address.



NOTE The Ping test can only be used with Symbol MUs.

5. Refer to the Number of Responses value to assess the number of responses from the MU versus the number of ping packets transmitted by the access point. Use the

ratio of packets sent to the number of packets received to determine the link quality between the MU and the access point.

6. Click **OK** to exit the Echo Test screen and return to the MU Stats Summary screen.

3.2.5 Creating a Mesh Point

In order for AP 7181s to mesh using MeshConnex, a Mesh Point must be created on each access point. Once created, mesh points can be applied to either radio (or both). A Root Mesh Point is an AP 7181 connected to the wired network (direct via Ethernet or via a wireless backhaul).

When configuring a Mesh Point on an AP 7181, you must define whether or not the AP 7181 is a Root Mesh Point. Non Root Mesh Points are simply referred to as Mesh Points. These Mesh Points are AP 7181's that *are not* connected to the wired network or wireless backhaul, although they may still have a camera or other device attached.

In previous Motorola Mesh products Root Mesh Points were referred to as IAPs and Non Root Mesh Points were referred to as MWRs. An AP 7181 can be configured as either a Root Mesh Point or a Non Root Mesh Point.

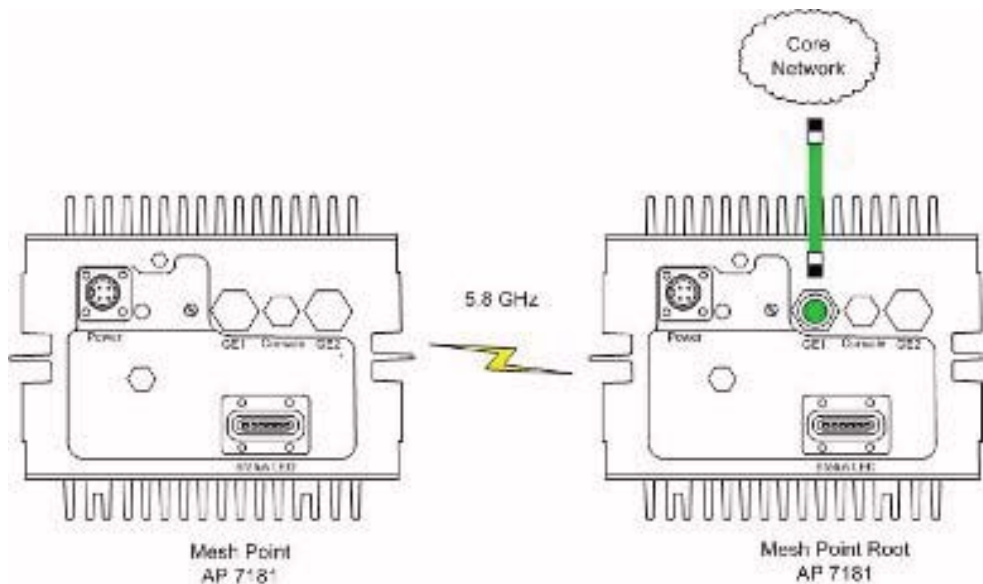

To create a Mesh Point:

1. Select **Network Configuration -> Wireless -> Radio Configuration -> Radio1** (or Radio2). Confirm that the **Channel Selection** parameter in the Channel, power and Rates Settings field is set to **Automatic**.

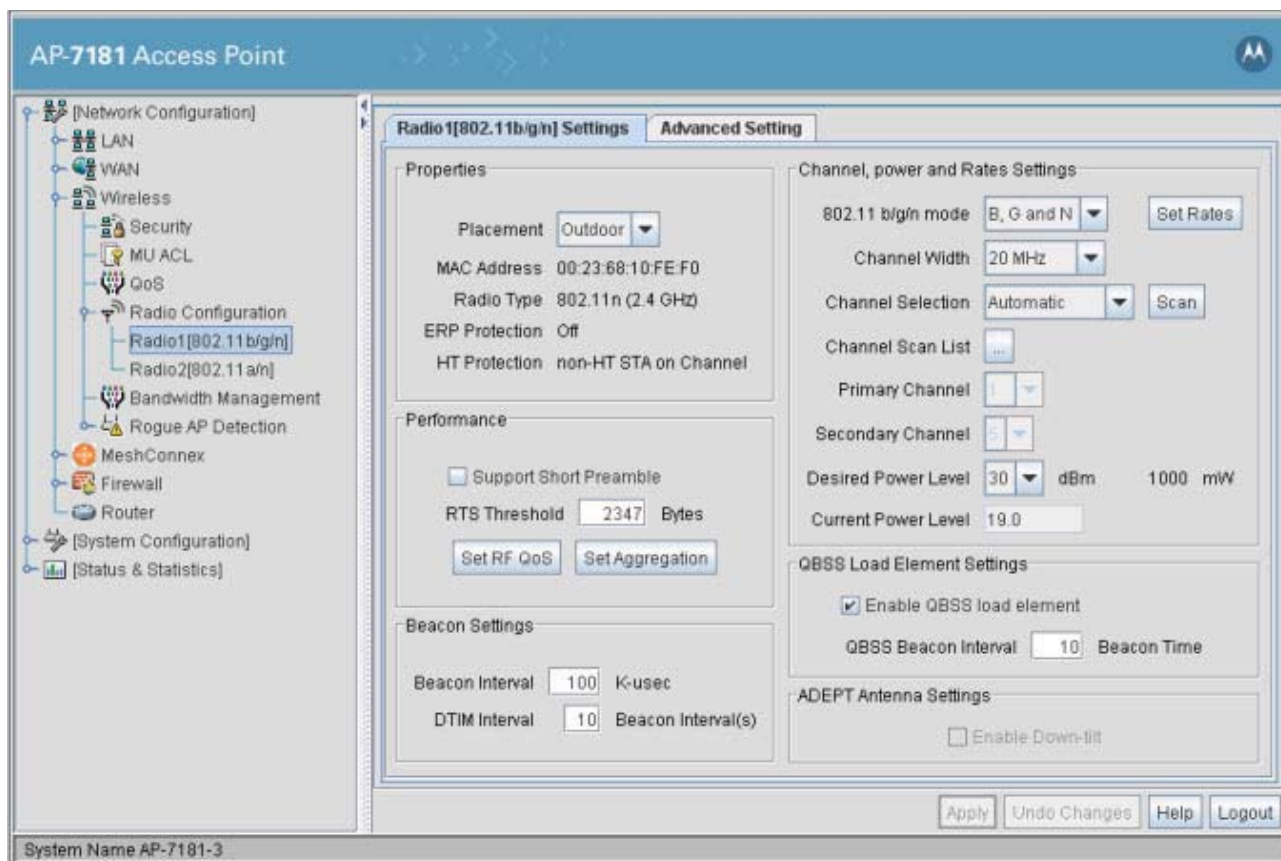

2. Select **Network Configuration -> MeshConnex** and click **Create**.

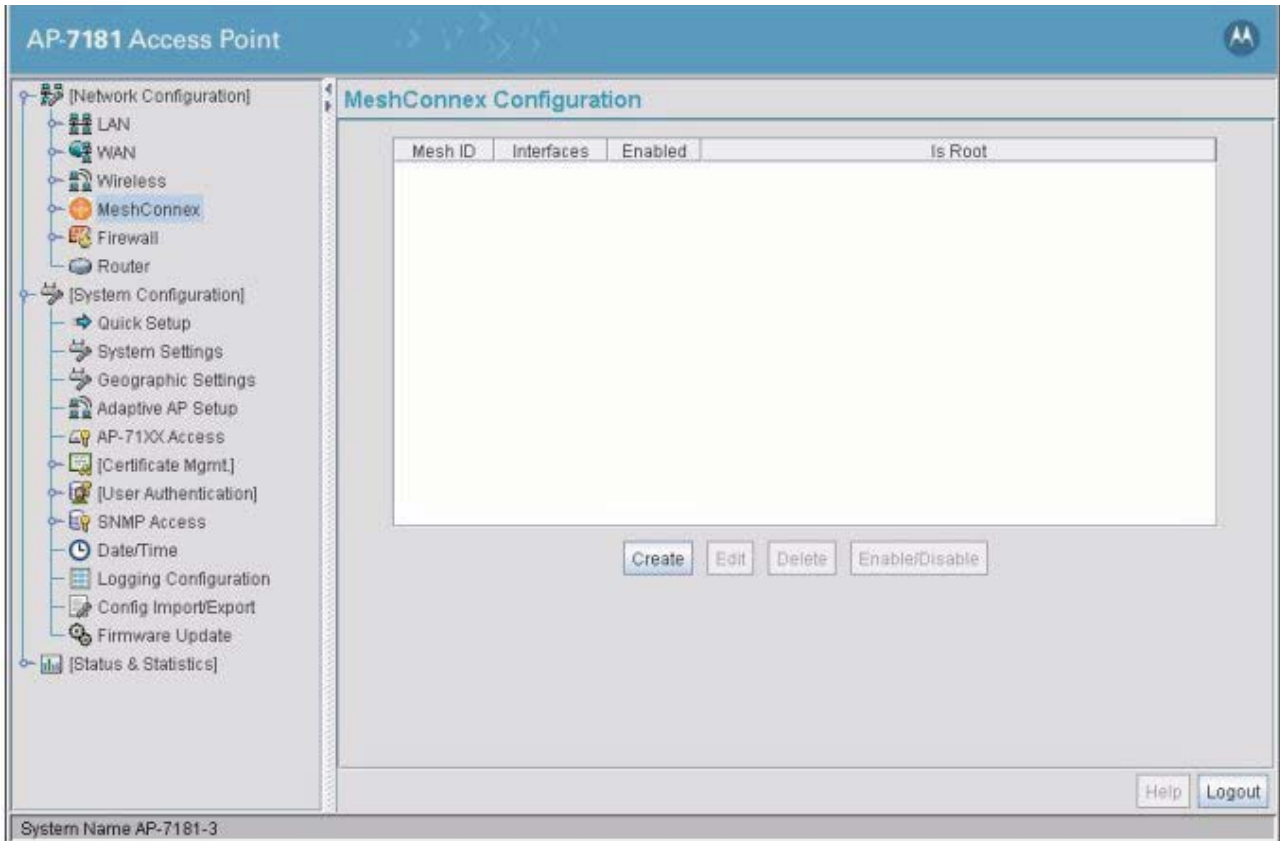

7. The New Mesh Point dialog is displayed. Enter a **Mesh ID** (case-sensitive). This Mesh ID must be the same on all AP 7181 devices. Next select a radio to mesh on by selecting the appropriate box under **Available On**. If this AP 7181 will be connected to the wired network (Root node / Gateway node) select the **Is Root** checkbox.

New Mesh Point

Configuration

Mesh ID

Available On 802.11 a/n Radio
 802.11 b/g/n Radio

Block Peer Communication

Is Root

Beacon Format ▼

Mesh Security

Static Proxy Configuration

Max Active MPs

Root Path Selection Preferences

Root Mesh Point (MPID)

Next Hop IFID

Next Hop Local Interface ▼

Apply Cancel

8. Click **Apply** to save your settings.

9. The Mesh Point you created will be displayed in the MeshConnex Configuration window. Highlight the Mesh Point and click **Enable**.

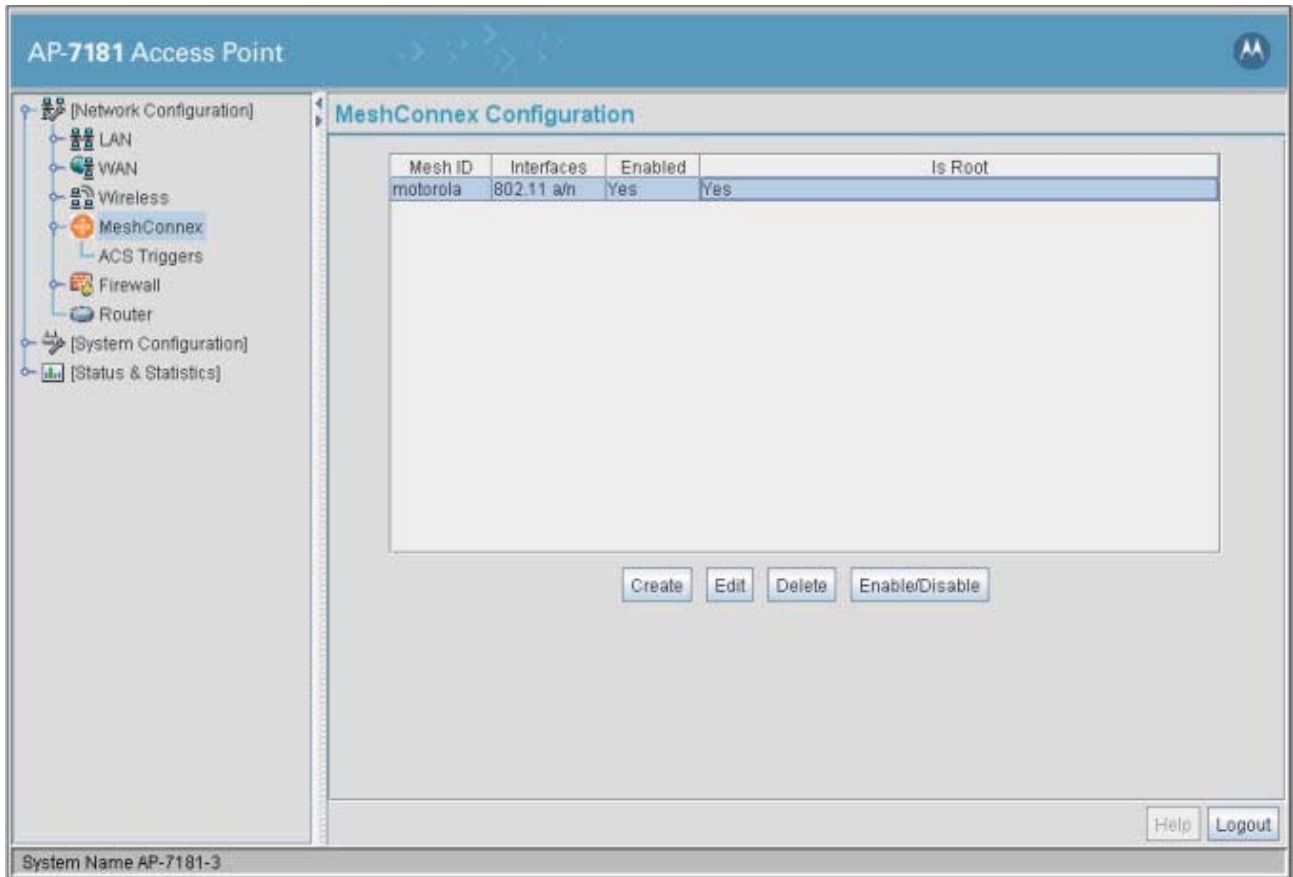

10. Repeat the process for each device you are staging.

11. To verify that a Mesh has been established, select **Status & Statistics** -> **MeshConnex Stats** and click on the name of the desired Mesh Point.
12. Select the **Neighbor** tab. In this example, only one neighbor is displayed.

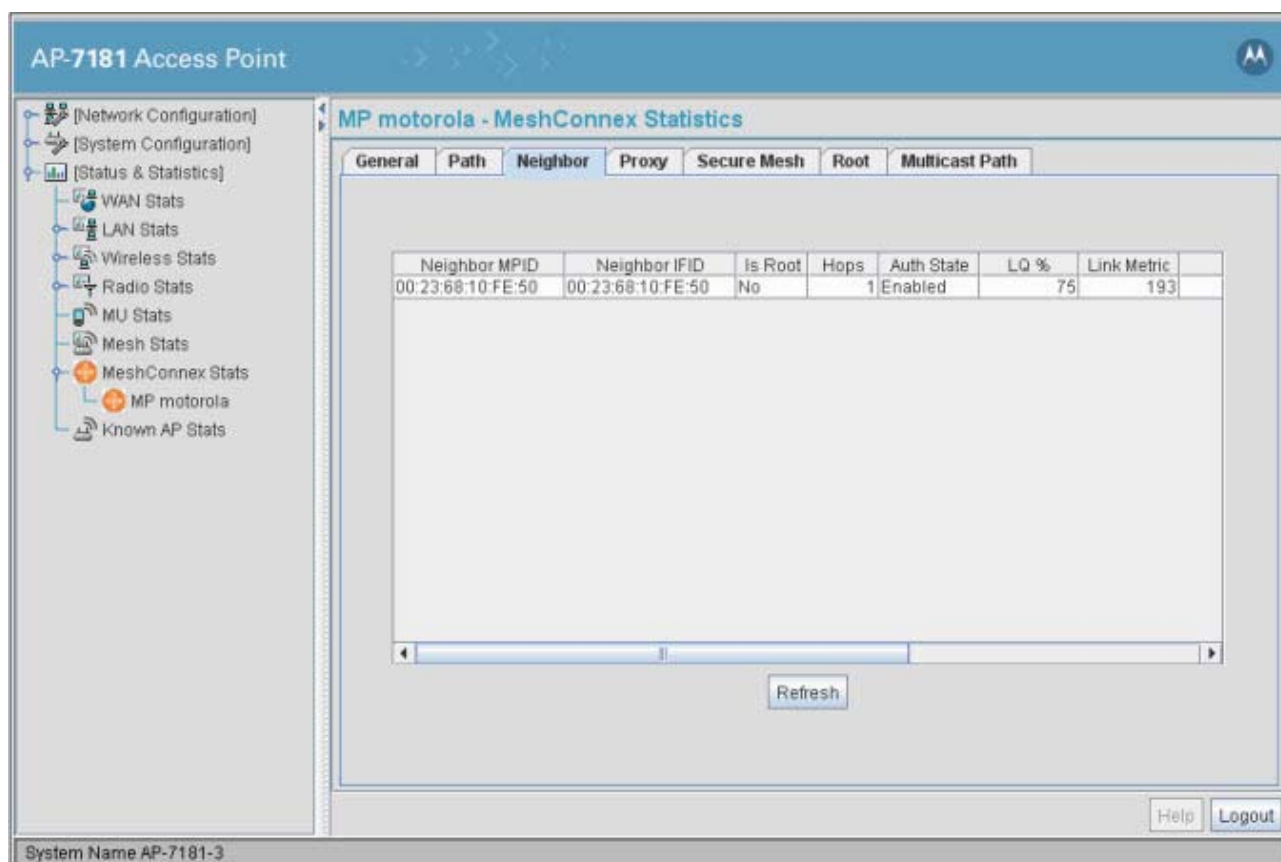

The screenshot displays the web interface for an AP-7181 Access Point. The left sidebar shows a navigation tree with categories: [Network Configuration], [System Configuration], and [Status & Statistics]. Under [Status & Statistics], there are sub-items: WAN Stats, LAN Stats, Wireless Stats, Radio Stats, MU Stats, Mesh Stats, MeshConnex Stats (selected), MP motorola (selected), and Known AP Stats. The main content area is titled "MP motorola - MeshConnex Statistics" and has several tabs: General, Path, Neighbor (selected), Proxy, Secure Mesh, Root, and Multicast Path. Below the tabs is a table with the following data:

Neighbor MPID	Neighbor IFID	Is Root	Hops	Auth State	LQ %	Link Metric
00:23:68:10:FE:50	00:23:68:10:FE:50	No	1	Enabled	75	193

Below the table is a "Refresh" button. At the bottom right of the interface are "Help" and "Logout" buttons. The system name "AP-7181-3" is visible at the bottom left.



NOTE A neighboring device will not be displayed in the table on the Neighbor tab if only a single device has been configured. Another Non-Root device must have already been created and the devices must be interconnected.

13. Select the **Path** tab to see if a route exists for each neighbor. The **Path State** should indicate Valid and the **Bind State** should indicate Bound.

The screenshot shows the web interface for an AP-7181 Access Point. The left sidebar contains a navigation tree with categories like [Network Configuration], [System Configuration], and [Status & Statistics]. The main content area is titled "MP motorola - MeshConnex Statistics" and has several tabs: General, Path, Neighbor, Proxy, Secure Mesh, Root, and Multicast Path. The "Path" tab is active, showing a table with the following data:

Destination	Is Root	Hops	Next Hop	Metric	Path State	Bind State
00:23:68:10:FE:50	No	1	00:23:68:10:FE:50	121	Valid	Bound

Below the table is a "Refresh" button. At the bottom right of the interface are "Help" and "Logout" buttons. The system name "AP-7181-3" is displayed at the bottom left.

3.3 Where to Go from Here?

Once basic connectivity has been verified, the access point can be fully configured to meet the needs of the network and the users it supports. Refer to the *AP 7181 Product Reference Guide* for detailed information on AP 7181 devices in wireless networks.

4 Regulatory Compliance

All Motorola devices are designed to be compliant with rules and regulations applicable to the locations where they are sold and will be labeled as required. Any changes or modifications to Motorola equipment, not expressly approved by Motorola, could void the user's authority to operate the equipment.

Motorola's devices are professionally installed. The Radio Frequency Output Power will not exceed the maximum allowable limit for the country of operation.

4.1 Health and Safety Recommendations

The Federal Communications Commission (FCC) with its action in ET Docket 96-8 has adopted a safety standard for human exposure to radio frequency (RF) electromagnetic energy emitted by FCC certified equipment. Motorola MOTOMESH products meet the uncontrolled environmental limits found in OET-65 and ANSI C95.1, 1991. Proper operation of this radio according to the instructions found in this manual and the AP 7181 Product Reference Guide will result in user exposure that is substantially below the FCC recommended limits.

4.1.1 Warnings for the Use of Wireless Devices

Please observe all warning notices with regard to the usage of wireless devices.

4.1.2 Potentially Hazardous Atmospheres

You are reminded of the need to observe restrictions on the use of radio devices in fuel depots, chemical plants etc. and areas where the air contains chemicals or particles (such as grain, dust, or metal powders).

4.1.3 Reducing RF Exposure—Use Properly

Only operate the device in accordance with the instructions supplied.

4.2 Power Supply

Use only the Motorola approved power supply output rated at 84 watts average, 126 watts peak. Use of alternative power supply will invalidate any approval given to this device and may be dangerous.

4.3 FCC Regulatory Information

This device complies with Part 15 of the FCC Rules. Operation is subject to the following two conditions: (1) this device may not cause harmful interference, and (2) this device must accept any interference received; including interference that may cause undesired operation.

This equipment has been tested and found to comply with the limits for a Class B digital device, pursuant to Part 15 of the FCC rules. These limits are designed to provide reasonable protection against harmful interference in a residential installation. This equipment generates, uses and can radiate radio frequency energy and, if not installed and used in accordance with the instructions, may cause harmful interference to radio communications. Operation of this equipment in a residential area is likely to cause harmful interference in which case the user will be required to correct the interference at his own expense.

- Do not touch or move the antenna(s) while the unit is transmitting or receiving.
- Do not hold any component containing a radio such that the antenna is very close to or touching any exposed parts of the body, especially the face or eyes, while transmitting.
- Do not operate a portable transmitter near unshielded blasting caps or in an explosive environment unless it is a type especially qualified for such use.
- Do not operate the radio or attempt to transmit data unless the antenna is connected; otherwise, the radio may be damaged.

4.3.1 RF Exposure

This equipment complies with the FCC RF radiation exposure limits set forth for an uncontrolled environment. This equipment should be installed and operated with a minimum distance of 20 centimeters between the radiator and your body.

This transmitter must not be co-located or operating in conjunction with any other antenna or transmitter.

The antennas used for this transmitter must be installed to provide a separation distance of at least 20cm from all persons and must not be located or operating in conjunction with any other antenna or transmitter.

To comply with FCC RF exposure compliance requirements, a separation distance of at least 33.9cm must be maintained between the user and antenna.

4.3.2 Intentional and Unintentional Radiators

Changes or modifications not expressly approved by Motorola could void the user's authority to operate the equipment.

4.4 Canada Requirements

This Class B digital apparatus complies with Canadian ICES-003.

For AC powered units use only the Motorola approved internal power supply rated at 48V output. Typical power is 84 watts average and 126 watts peak. Use of alternative power supply will invalidate any approval given to this device and may be dangerous.

5 Customer Support

If you have read this document and made every effort to resolve installation or operation issues yourself and still require support, please contact your regional Motorola support representatives or visit the Motorola Mesh Networks web site at:

<http://motorola.wirelessbroadbandsupport.com/support/mesh/contact.php>



MOTOROLA INC
1303 E. ALGONQUIN ROAD
SCHAUMBURG, IL 60196
<http://www.motorola.com>

Version 1.0.0.A
March 2010