



FCC Radio Test Report

FCC ID: QISWS319

This report concerns (check one): Original Grant Class II Change

Issued Date : Jan. 22, 2014
Project No. : 1401C069
Equipment : 300Mbps Wireless Router
Model Name : WS319
Applicant : Huawei Technologies Co.,Ltd.
Address : Administration Building, Headquarters
of Huawei Technologies Co., Ltd.,
Bantian, Longgang District, 518129
Shenzhen, P.R.C

Tested by: Neutron Engineering Inc. EMC Laboratory

Date of Receipt: Jan. 13, 2014

Date of Test: Jan. 13, 2014 ~ Jan. 21, 2014

Testing Engineer : David Mao
(David Mao)

Technical Manager : Leo Hung
(Leo Hung)

Authorized Signatory : Steven Lu
(Steven Lu)

Neutron Engineering Inc.

No.3,Jinshagang 1st Road, ShiXia,

Dalang Town, Dong Guan, China.

TEL: 0769-8318-3000

FAX: 0769-8319-6000



Declaration

Neutron represents to the client that testing is done in accordance with standard procedures as applicable and that test instruments used has been calibrated with the standards traceable to National Measurement Laboratory (**NML**) of **R.O.C.**, or National Institute of Standards and Technology (**NIST**) of **U.S.A.**

Neutron's reports apply only to the specific samples tested under conditions. It is manufacture's responsibility to ensure that additional production units of this model are manufactured with the identical electrical and mechanical components. **Neutron** shall have no liability for any declarations, inferences or generalizations drawn by the client or others from **Neutron** issued reports.

Neutron's reports must not be used by the client to claim product endorsement by the authorities or any agency of the Government.

This report is the confidential property of the client. As a mutual protection to the clients, the public and **Neutron-self**, extracts from the test report shall not be reproduced except in full with **Neutron's** authorized written approval.

Neutron's laboratory quality assurance procedures are in compliance with the **ISO Guide 17025** requirements, and accredited by the conformity assessment authorities listed in this test report.

Limitation

For the use of the authority's logo is limited unless the Test Standard(s)/Scope(s)/Item(s) mentioned in this test report is (are) included in the conformity assessment authorities acceptance respective.



Table of Contents	Page
1 . CERTIFICATION	6
2 . SUMMARY OF TEST RESULTS	7
2.1 TEST FACILITY	8
2.2 MEASUREMENT UNCERTAINTY	8
3 . GENERAL INFORMATION	9
3.1 GENERAL DESCRIPTION OF EUT	9
3.2 DESCRIPTION OF TEST MODES	11
3.3 TABLE OF PARAMETERS OF TEXT SOFTWARE SETTING	12
3.4 BLOCK DIAGRAM SHOWING THE CONFIGURATION OF SYSTEM TESTED	13
3.5 DESCRIPTION OF SUPPORT UNITS	14
4 . EMC EMISSION TEST	15
4.1 CONDUCTED EMISSION MEASUREMENT	15
4.1.1 POWER LINE CONDUCTED EMISSION LIMITS	15
4.1.2 TEST PROCEDURE	15
4.1.3 DEVIATION FROM TEST STANDARD	15
4.1.4 TEST SETUP	16
4.1.5 EUT OPERATING CONDITIONS	16
4.1.6 EUT TEST CONDITIONS	16
4.1.7 TEST RESULTS	16
4.2 RADIATED EMISSION MEASUREMENT	19
4.2.1 RADIATED EMISSION LIMITS	19
4.2.2 TEST PROCEDURE	20
4.2.3 DEVIATION FROM TEST STANDARD	20
4.2.4 TEST SETUP	21
4.2.5 EUT OPERATING CONDITIONS	22
4.2.6 EUT TEST CONDITIONS	22
4.2.7 TEST RESULTS (9K~ 30MHZ)	23
4.2.8 TEST RESULTS (BETWEEN 30 – 1000 MHZ)	24
4.2.9 TEST RESULTS (ABOVE 1000 MHZ)	31
5 . BANDWIDTH TEST	68
5.1 APPLIED PROCEDURES	68
5.1.1 TEST PROCEDURE	68
5.1.2 DEVIATION FROM STANDARD	68
5.1.3 TEST SETUP	68
5.1.4 EUT OPERATION CONDITIONS	68
5.1.5 EUT TEST CONDITIONS	68
5.1.6 TEST RESULTS	69



Table of Contents	Page
6 . MAXIMUM OUTPUT POWER TEST	81
6.1 APPLIED PROCEDURES / LIMIT	81
6.1.1 TEST PROCEDURE	81
6.1.2 DEVIATION FROM STANDARD	81
6.1.3 TEST SETUP	81
6.1.4 EUT OPERATION CONDITIONS	81
6.1.5 EUT TEST CONDITIONS	81
6.1.6 TEST RESULTS	82
7 . ANTENNA CONDUCTED SPURIOUS EMISSION	85
7.1 APPLIED PROCEDURES / LIMIT	85
7.1.1 TEST PROCEDURE	85
7.1.2 DEVIATION FROM STANDARD	85
7.1.3 TEST SETUP	85
7.1.4 EUT OPERATION CONDITIONS	85
7.1.5 EUT TEST CONDITIONS	85
7.1.6 TEST RESULTS	86
8 . POWER SPECTRAL DENSITY TEST	116
8.1 APPLIED PROCEDURES / LIMIT	116
8.1.1 TEST PROCEDURE	116
8.1.2 DEVIATION FROM STANDARD	116
8.1.3 TEST SETUP	116
8.1.4 EUT OPERATION CONDITIONS	116
8.1.5 EUT TEST CONDITIONS	116
8.1.6 TEST RESULTS	117
9 . MEASUREMENT INSTRUMENTS LIST	131
10 . EUT TEST PHOTO	133



REPORT ISSUED HISTORY

Issued No.	Description	Issued Date
NEI-FCCP-1-1401C069	Original Issue.	Jan. 22, 2014



1. CERTIFICATION

Equipment : 300Mbps Wireless Router
Brand Name : HUAWEI
Model Name : WS319
Applicant : Huawei Technologies Co.,Ltd.
Manufacturer: Huawei Technologies Co.,Ltd.
Address : Administration Building, Headquarters of Huawei Technologies Co., Ltd.,
Bantian, Longgang District, 518129 Shenzhen, P.R.C
Factory : Shenzhen Allwins Technology Corporation Baoan Branch
Address : Block A&M, Shasi Hi-Tech Park, Shajing Street, Shenzhen
Date of Test : Jan. 13, 2014 ~ Jan. 21, 2014
Test Item : ENGINEERING SAMPLE
Standard(s) : FCC Part15, Subpart C(15.247) / ANSI C63.4-2009

The above equipment has been tested and found compliance with the requirement of the relative standards by Neutron Engineering Inc. EMC Laboratory.

The test data, data evaluation, and equipment configuration contained in our test report (Ref No. NEI-FCCP-1-1401C069) were obtained utilizing the test procedures, test instruments, test sites that has been accredited by the Authority of TAF according to the ISO-17025 quality assessment standard and technical standard(s).



2. SUMMARY OF TEST RESULTS

Test procedures according to the technical standard(s):

Applied Standard(s): FCC Part15 (15.247) , Subpart C				
Standard(s)	Section	Test Item	Judgment	Remark
15.207		Conducted Emission	PASS	
15.247(d)		Antenna conducted Spurious Emission	PASS	
15.247(a)(2)		6dB Bandwidth	PASS	
15.247(b)(3)		Peak Output Power	PASS	
15.247(e)		Power Spectral Density	PASS	
15.203		Antenna Requirement	PASS	
15.209/15.205		Transmitter Radiated Emissions	PASS	
-		Receiver Radiated Emissions	PASS	

NOTE:

- (1) " N/A" denotes test is not applicable in this test report.
- (2) The test follows FCC KDB Publication No. 558074 D01 DTS Meas Guidance v03r01 (Measurement Guidelines of DTS)



2.1 TEST FACILITY

The test facilities used to collect the test data in this report is **DG-C02/DG-CB03** at the location of No.3,Jinshagang 1st Road, ShiXia, Dalang Town, Dong Guan, China.523792
 Neutron's test firm number for FCC: 319330

2.2 MEASUREMENT UNCERTAINTY

Where relevant, the following measurement uncertainty levels have been estimated for tests performed on the EUT as specified in CISPR 16-4-2:

The reported uncertainty of measurement $y \pm U$, where expanded uncertainty U is based on a standard uncertainty multiplied by a coverage factor of $k=2$, providing a level of confidence of approximately 95 %.

A. Conducted Measurement :

Test Site	Method	Measurement Frequency Range	U , (dB)	NOTE
DG-C02	CISPR	150 KHz ~ 30MHz	1.94	

B. Radiated Measurement :

Test Site	Method	Measurement Frequency Range	Ant. H / V	U , (dB)	NOTE
DG-CB03	CISPR	9KHz~30MHz	V	3.79	
		9KHz~30MHz	H	3.57	
		30MHz ~ 200MHz	V	3.82	
		30MHz ~ 200MHz	H	3.60	
		200MHz ~ 1,000MHz	V	3.86	
		200MHz ~ 1,000MHz	H	3.94	
		1GHz~18GHz	V	3.12	
		1GHz~18GHz	H	3.68	
		18GHz~40GHz	V	4.15	
		18GHz~40GHz	H	4.14	



3. GENERAL INFORMATION

3.1 GENERAL DESCRIPTION OF EUT

Equipment	300Mbps Wireless Router	
Brand Name	HUAWEI	
Model Name	WS319	
Model Difference	N/A	
Product Description	Operation Frequency	2412~2462 MHz
	Modulation Technology	802.11b:DSSS 802.11g:OFDM 802.11n:OFDM
	Bit Rate of Transmitter	802.11b: 11/5.5/2/1 Mbps 802.11g: 54/48/36/24/18/12/9/6 Mbps 802.11n up to 300 Mbps
	Output Power (Max.)	802.11b: 16.82 dBm 802.11g: 24.40dBm 802.11n(20MHz): 26.17dBm 802.11n(40MHz): 22.86dBm
Power Source	DC voltage supplied from AC/DC adapter. #1 Brand/Model: HUAWEI / HW-120050U1W (HKACA2896845) #2 Brand/Model: HUAWEI / HW-120050U1W (XQHD52300858)	
Power Rating	#1 I/P: AC 100-240V~50/60Hz 0.2A O/P: DC 12V 0.5A #2 I/P: AC 100-240V~50/60Hz 0.2A O/P: DC 12V 0.5A	
Connecting I/O Port(s)	Please refer to the User's Manual	

Note:

1. For a more detailed features description, please refer to the manufacturer's specifications or the User's Manual.



2. CH 01 – CH 11 for 802.11b, 802.11g, 802.11n(20MHz)
 CH 03 – CH 09 for 802.11n(40MHz)

Channel List							
Channel	Frequency (MHz)	Channel	Frequency (MHz)	Channel	Frequency (MHz)	Channel	Frequency (MHz)
01	2412	04	2427	07	2442	10	2457
02	2417	05	2432	08	2447	11	2462
03	2422	06	2437	09	2452		

3. Table for Filed Antenna

Ant.	Manufacturer	Model Name	Antenna Type	Connector	Gain (dBi)	Note
1	DONGGUAN SENLING INDUSTRIAL CO.,LTD	SLA-200200180	Dipole	N/A	5	
2	DONGGUAN SENLING INDUSTRIAL CO.,LTD	SLA-200200070	Dipole	N/A	5	

Note: The EUT incorporates a MIMO function. Physically, the EUT provides two completed transmitters and two receivers (2T2R), all transmit signals are completely uncorrelated, then, Direction gain = G_{ANT} , that is Directional gain=5.

- 4.

Operating Mode / TX Mode	1TX	2TX
	802.11b	V (ANT 1 or ANT 2)
802.11g	V (ANT 1 or ANT 2)	-
802.11n(20MHz)	-	V (ANT 1 & ANT 2)
802.11n(40MHz)	-	V (ANT 1 & ANT 2)



3.2 DESCRIPTION OF TEST MODES

To investigate the maximum EMI emission characteristics generates from EUT, the test system was pre-scanning tested base on the consideration of following EUT operation mode or test configuration mode which possible have effect on EMI emission level. Each of these EUT operation mode(s) or test configuration mode(s) mentioned above was evaluated respectively.

Pretest Mode	Description
Mode 1	TX B MODE CHANNEL 01/06/11
Mode 2	TX G MODE CHANNEL 01/06/11
Mode 3	TX N-20MHZ MODE CHANNEL 01/06/11
Mode 4	TX N-40MHZ MODE CHANNEL 03/06/09
Mode 5	WIFI

The EUT system operated these modes were found to be the worst case during the pre-scanning test as following:

For Conducted Test	
Final Test Mode	Description
Mode 5	WIFI

For Radiated Test	
Final Test Mode	Description
Mode 1	TX B MODE CHANNEL 01/06/11
Mode 2	TX G MODE CHANNEL 01/06/11
Mode 3	TX N-20MHZ MODE CHANNEL 01/06/11
Mode 4	TX N-40MHZ MODE CHANNEL 03/06/09

Note:

- (1) The measurements are performed at the high, middle, low available channels.
- (2) 802.11b mode: DBPSK (1Mbps)
 802.11g mode: OFDM (6Mbps)
 802.11n HT20 mode : BPSK (6.5Mbps)
 802.11n HT40 mode : BPSK (13.5Mbps)
 For radiated emission tests, the highest output powers were set for final test.
- (3) The EUT system operated two adapters(S/N: HKACA2896845 and S/N: XQHD52300858) were found to be the worst case during the pre-scanning test as HKACA2896845.



3.3 TABLE OF PARAMETERS OF TEXT SOFTWARE SETTING

During testing, channel & power controlling software provided by the customer was used to control the operating channel as well as the output power level. The RF output power selection is for the setting of RF output power expected by the customer and is going to be fixed on the firmware of the final end product power parameters of WLAN

Test software version	SmartTools		
Frequency	2412 MHz	2437 MHz	2462 MHz
IEEE 802.11b DSSS	44	44	44
IEEE 802.11g OFDM	49	49	48

Test software version	SmartTools		
Frequency (MHz)	2412 MHz	2437 MHz	2462 MHz
IEEE 802.11n (20MHz)	43	43	43
Frequency (MHz)	2422 MHz	2437 MHz	2452 MHz
IEEE 802.11n (40MHz)	39	39	39



3.4 BLOCK DIAGRAM SHOWING THE CONFIGURATION OF SYSTEM TESTED

Conducted TX Mode:

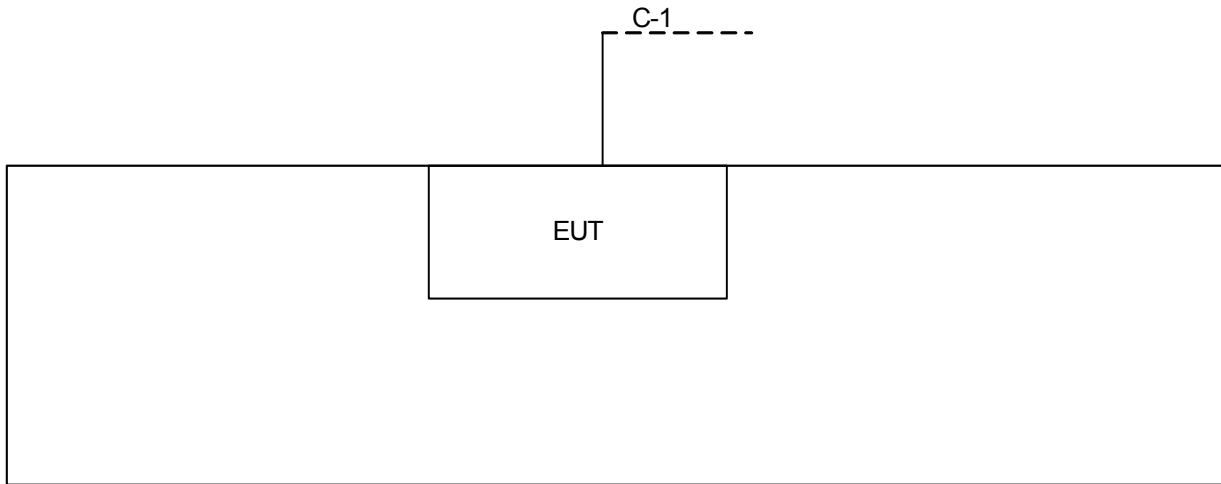

Control Room

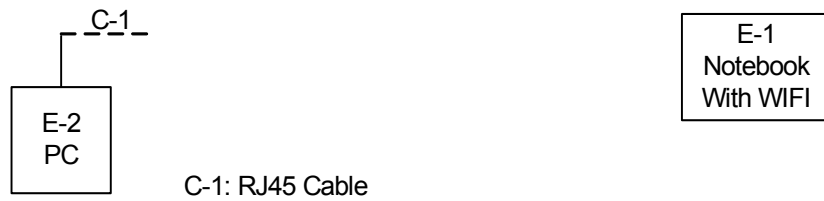

Radiated TX Mode:

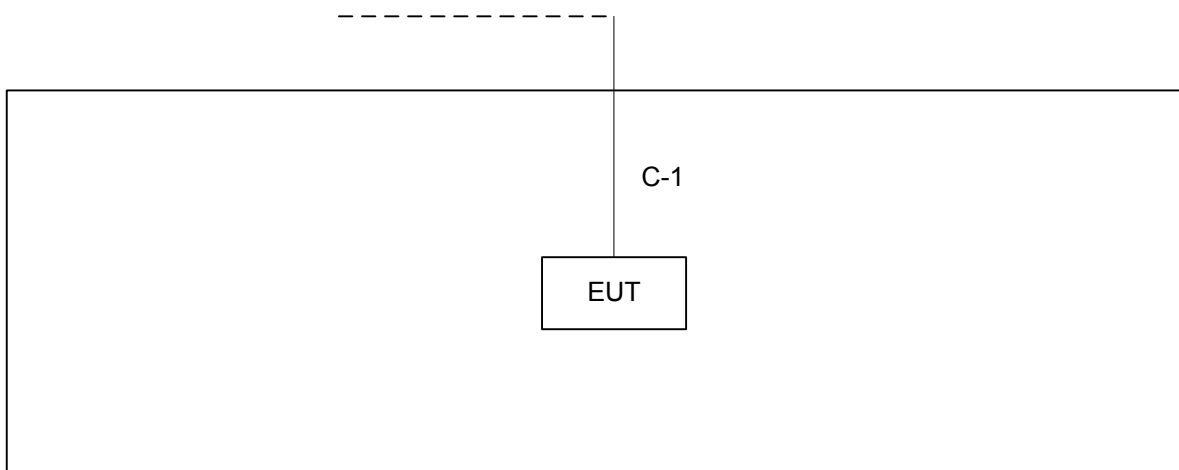

Control Room

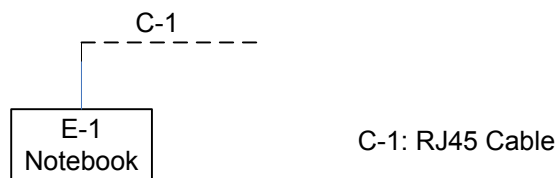



3.5 DESCRIPTION OF SUPPORT UNITS

The EUT has been tested as an independent unit together with other necessary accessories or support units. The following support units or accessories were used to form a representative test configuration during the tests.

Item	Equipment	Mfr/Brand	Model/Type No.	FCC ID	Series No.	Note
E-1	NOTEBOOK	DELL	INSPIRON 1420	DOC	JX193A01SDC2	-
E-2	PC	HP	Dx7400	DOC	CNG7430PX0	

Item	Shielded Type	Ferrite Core	Length	Note
C-1	NO	NO	10m	



4. EMC EMISSION TEST

4.1 CONDUCTED EMISSION MEASUREMENT

4.1.1 POWER LINE CONDUCTED EMISSION Limits (Frequency Range 150KHz-30MHz)

Frequency (MHz)	Class A (dBuV)		Class B (dBuV)		Standard
	Quasi-peak	Average	Quasi-peak	Average	
0.15 -0.5	79.00	66.00	66 - 56 *	56 - 46 *	CISPR
0.50 -5.0	73.00	60.00	56.00	46.00	CISPR
5.0 -30.0	73.00	60.00	60.00	50.00	CISPR
0.15 -0.5	79.00	66.00	66 - 56 *	56 - 46 *	FCC
0.50 -5.0	73.00	60.00	56.00	46.00	FCC
5.0 -30.0	73.00	60.00	60.00	50.00	FCC

Note:

- (1) The tighter limit applies at the band edges.
- (2) The limit of " * " marked band means the limitation decreases linearly with the logarithm of the frequency in the range.

The following table is the setting of the receiver

Receiver Parameters	Setting
Attenuation	10 dB
Start Frequency	0.15 MHz
Stop Frequency	30 MHz
IF Bandwidth	9 KHz

4.1.2 TEST PROCEDURE

- a. The EUT was placed 0.8 meters from the horizontal ground plane with EUT being connected to the power mains through a line impedance stabilization network (LISN). All other support equipments powered from additional LISN(s). The LISN provide 50 Ohm/ 50uH of coupling impedance for the measuring instrument.
- b. Interconnecting cables that hang closer than 40 cm to the ground plane shall be folded back and forth in the center forming a bundle 30 to 40 cm long.
- c. I/O cables that are not connected to a peripheral shall be bundled in the center. The end of the cable may be terminated, if required, using the correct terminating impedance. The overall length shall not exceed 1 m.
- d. LISN at least 80 cm from nearest part of EUT chassis.
- e. For the actual test configuration, please refer to the related Item –EUT Test Photos.

4.1.3 DEVIATION FROM TEST STANDARD

No deviation

4.1.4 TEST SETUP

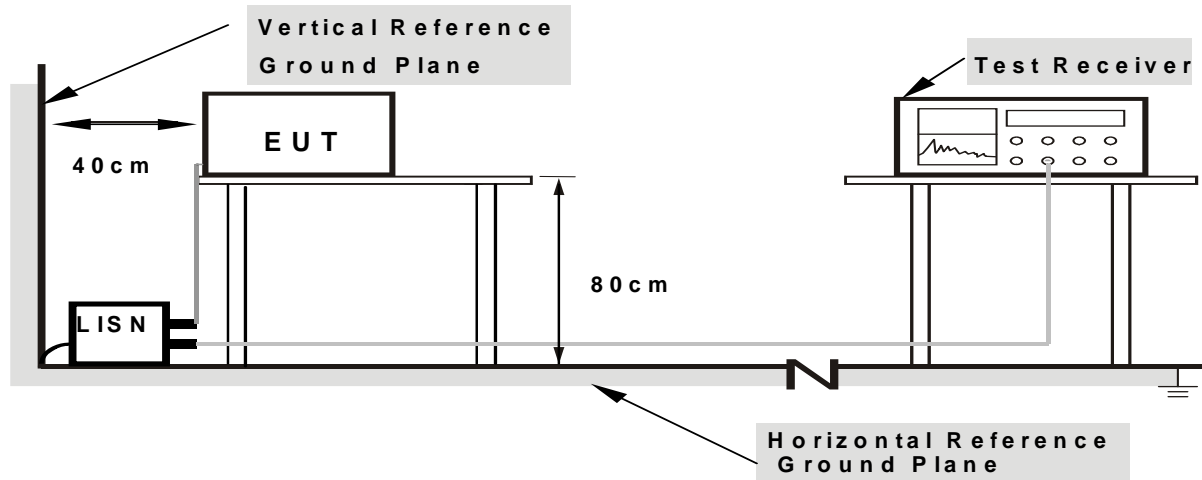

- Note:**
- 1. Support units were connected to second LISN.
 - 2. Both of LISNs (AMN) are 80 cm from EUT and at least 80 from other units and other metal planes

4.1.5 EUT OPERATING CONDITIONS

The EUT was configured for testing in a typical fashion (as a customer would normally use it). The EUT has been programmed to continuously transmit during test. This operating condition was tested and used to collect the included data.

4.1.6 EUT TEST CONDITIONS

Temperature: 25°C
 Relative Humidity: 55%
 Test Voltage: 120V/60Hz

4.1.7 TEST RESULTS

Remark:

- (1) All readings are QP Mode value unless otherwise stated AVG in column of 『Note 』. If the QP Mode Measured value compliance with the QP Limits and lower than AVG Limits, the EUT shall be deemed to meet both QP & AVG Limits and then only QP Mode was measured, but AVG Mode didn't perform. In this case, a “ * ” marked in AVG Mode column of Interference Voltage Measured.
- (2) Measuring frequency range from 150KHz to 30MHz.



Test Mode : WIFI (Adapter: HKACA2896845)

Line

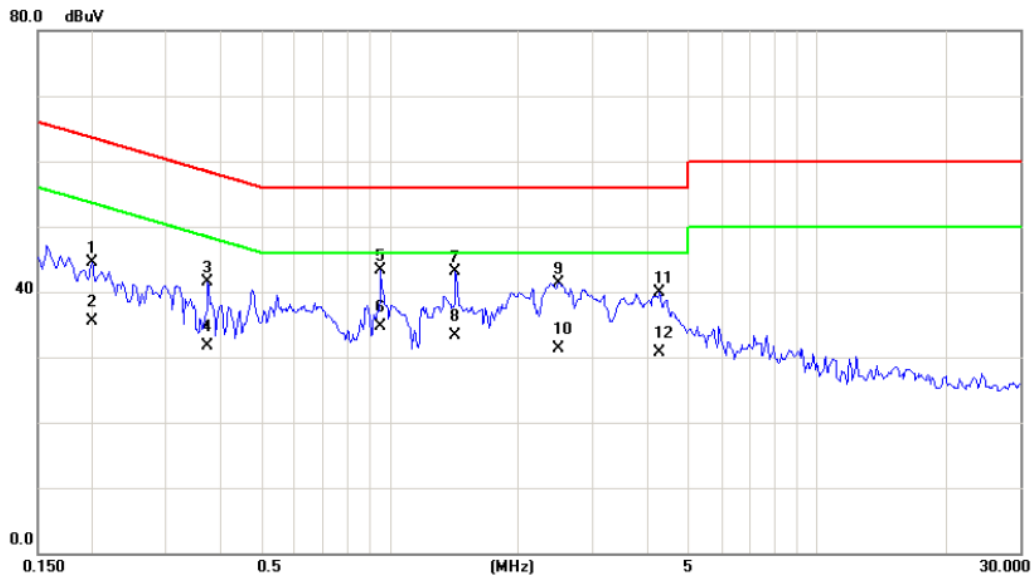

No. Mk.	Freq. MHz	Reading Level dBuV	Correct Factor dB	Measurement dBuV	Limit dBuV	Over dB	Detector	Comment
1	0.2006	34.97	9.62	44.59	63.59	-19.00	peak	
2	0.2006	25.97	9.62	35.59	53.59	-18.00	AVG	
3	0.3765	31.78	9.65	41.43	58.36	-16.93	peak	
4	0.3765	21.98	9.65	31.63	48.36	-16.73	AVG	
5	0.9546	33.66	9.72	43.38	56.00	-12.62	peak	
6 *	0.9546	24.89	9.72	34.61	46.00	-11.39	AVG	
7	1.4312	33.42	9.73	43.15	56.00	-12.85	peak	
8	1.4312	23.65	9.73	33.38	46.00	-12.62	AVG	
9	2.4937	31.51	9.79	41.30	56.00	-14.70	peak	
10	2.4937	21.55	9.79	31.34	46.00	-14.66	AVG	
11	4.2968	30.08	9.87	39.95	56.00	-16.05	peak	
12	4.2968	20.78	9.87	30.65	46.00	-15.35	AVG	



Test Mode : WIFI (Adapter: HKACA2896845)

Neutral

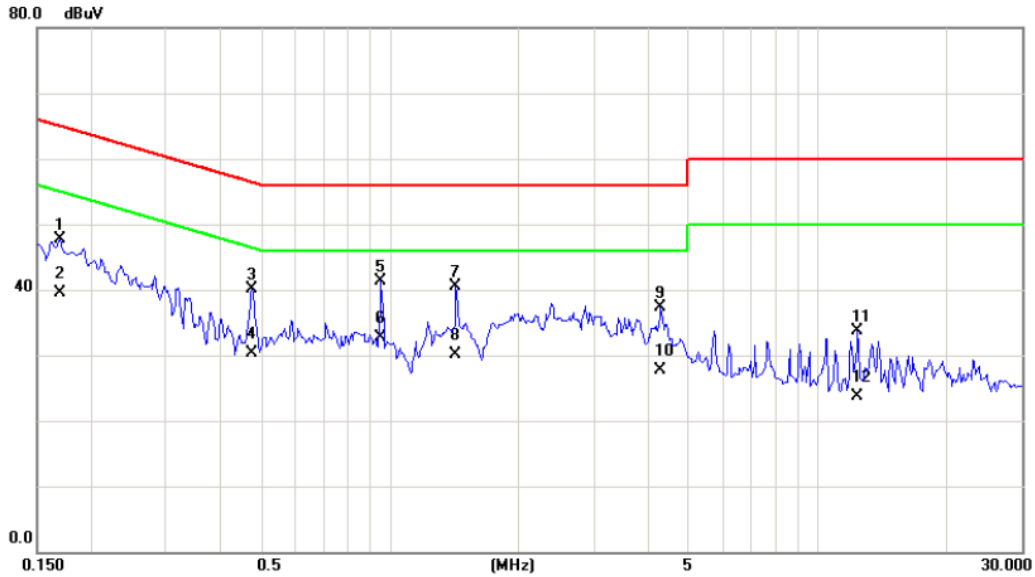

No.	Mk.	Freq. MHz	Reading Level dBuV	Correct Factor dB	Measure- ment dBuV	Limit dBuV	Over dB	Detector	Comment
1		0.1695	38.04	9.60	47.64	64.98	-17.34	peak	
2		0.1695	29.97	9.60	39.57	54.98	-15.41	AVG	
3		0.4781	30.45	9.67	40.12	56.37	-16.25	peak	
4		0.4781	20.57	9.67	30.24	46.37	-16.13	AVG	
5		0.9546	31.65	9.73	41.38	56.00	-14.62	peak	
6	*	0.9546	22.89	9.73	32.62	46.00	-13.38	AVG	
7		1.4312	30.70	9.75	40.45	56.00	-15.55	peak	
8		1.4312	20.39	9.75	30.14	46.00	-15.86	AVG	
9		4.3006	27.41	9.92	37.33	56.00	-18.67	peak	
10		4.3006	17.72	9.92	27.64	46.00	-18.36	AVG	
11		12.4180	23.29	10.47	33.76	60.00	-26.24	peak	
12		12.4180	13.31	10.47	23.78	50.00	-26.22	AVG	



4.2 RADIATED EMISSION MEASUREMENT

4.2.1 RADIATED EMISSION LIMITS (Frequency Range 9KHz-1000MHz)

20dB in any 100 KHz bandwidth outside the operating frequency band. In case the emission fall within the restricted band specified on 15.205(a) & RSS-210 section 2.2& Annex 8 (A8.5), then the 15.209(a)& RSS-Gen limit in the table below has to be followed.

Frequency (MHz)	Field Strength (microvolts/meter)	Measurement Distance (meters)
0.009~0.490	2400/F(KHz)	300
0.490~1.705	24000/F(KHz)	30
1.705~30.0	30	30
30~88	100	3
88~216	150	3
216~960	200	3
960~1000	500	3

LIMITS OF RADIATED EMISSION MEASUREMENT (Above 1000MHz)

Frequency (MHz)	(dBuV/m) (at 3 meters)	
	PEAK	AVERAGE
Above 1000	74	54

Notes:

- (1) The limit for radiated test was performed according to FCC PART 15C.
- (2) The tighter limit applies at the band edges.
- (3) Emission level (dBuV/m)=20log Emission level (uV/m).

Spectrum Parameter	Setting
Attenuation	Auto
Start Frequency	1000 MHz
Stop Frequency	10th carrier harmonic
RBW / VBW (Emission in restricted band)	1MHz / 1MHz for Peak, 1 MHz / 10Hz for Average

Receiver Parameter	Setting
Attenuation	Auto
Start ~ Stop Frequency	9KHz~90KHz for PK/AVG detector
Start ~ Stop Frequency	90KHz~110KHz for QP detector
Start ~ Stop Frequency	110KHz~490KHz for PK/AVG detector
Start ~ Stop Frequency	490KHz~30MHz for QP detector
Start ~ Stop Frequency	30MHz~1000MHz for QP detector



4.2.2 TEST PROCEDURE

- a. The EUT was placed on the top of a rotating table 0.8 meters above the ground at a 3 meter semi-anechoic chamber. The table was rotated 360 degrees to determine the position of the highest radiation.(below 1GHz)
- b. The EUT was placed on the top of a rotating table 0.8 meters above the ground at a 3 meter fully-anechoic chamber. The table was rotated 360 degrees to determine the position of the highest radiation.(above 1GHz)
- c. The height of the equipment or of the substitution antenna shall be 0.8 m; the height of the test antenna shall vary between 1 m to 4 m. Both horizontal and vertical polarizations of the antenna are set to make the measurement.
- d. The initial step in collecting conducted emission data is a spectrum analyzer peak detector mode pre-scanning the measurement frequency range. Significant peaks are then marked and then Quasi Peak detector mode re-measured.
- e. If the Peak Mode measured value compliance with and lower than Quasi Peak Mode Limit, the EUT shall be deemed to meet QP Limits and then no additional QP Mode measurement performed.
- f. For the actual test configuration, please refer to the related Item –EUT Test Photos.

4.2.3 DEVIATION FROM TEST STANDARD

No deviation

4.2.4 TEST SETUP

(A) Radiated Emission Test Set-Up Frequency Below 1 GHz

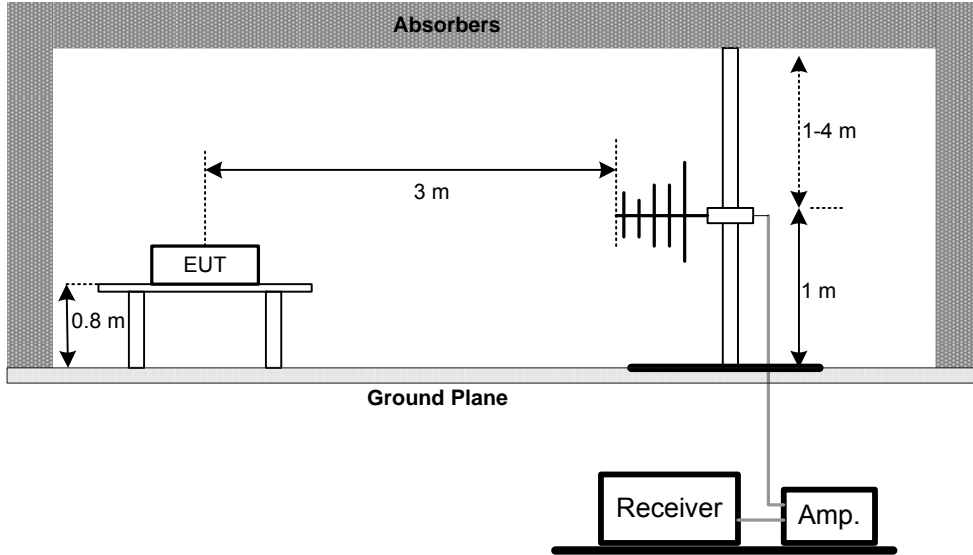

(B) Radiated Emission Test Set-Up Frequency Above 1 GHz

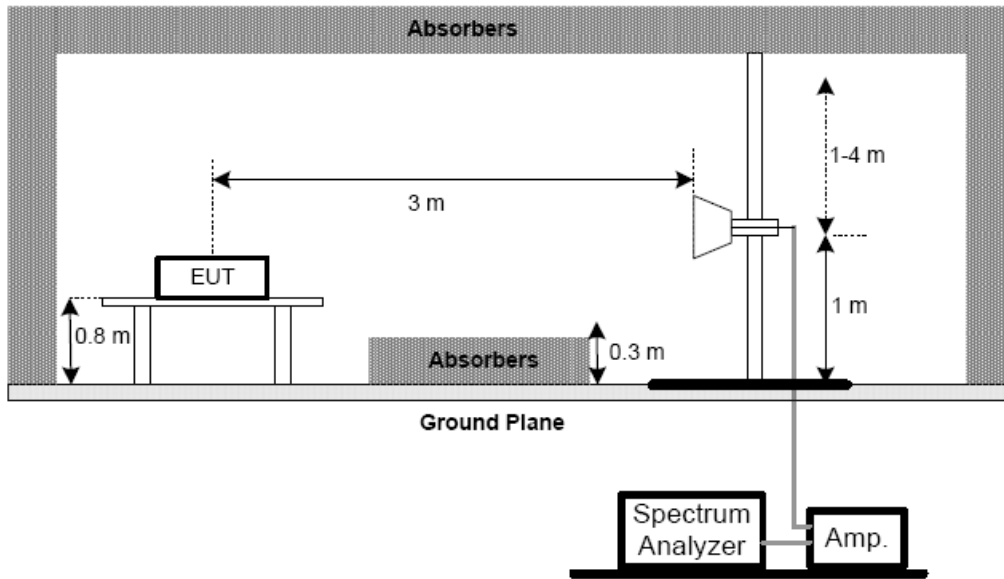

(C) For radiated emissions below 30MHz

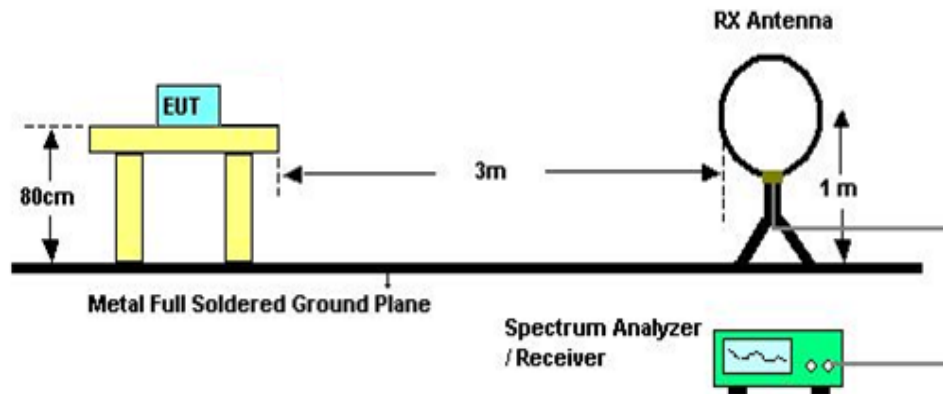

4.2.5 EUT OPERATING CONDITIONS

The EUT tested system was configured as the statements of 4.1.6 Unless otherwise a special operating condition is specified in the follows during the testing.

4.2.6 EUT TEST CONDITIONS

Temperature: 25°C

Relative Humidity: 55%

Test Voltage: 120V/60Hz



4.2.7 TEST RESULTS (9K~ 30MHZ)

Test Mode : TX Mode 2412MHz

Freq. (MHz)	Ant. 0°/90°	Reading(RA) (dBuV)	Corr.Factor(CF) (dB)	Measured(FS) (dBuV/m)	Limits(QP) (dBuV/m)	Margin (dB)	Note
0.0093	0°	25.21	24.30	49.51	128.23	-78.72	AV
0.0093	0°	29.21	24.30	53.51	148.23	-94.72	PK
0.0254	0°	21.05	23.96	45.01	119.50	-74.50	AV
0.0254	0°	24.41	23.96	48.37	139.50	-91.14	PK
0.0385	0°	21.26	23.13	44.39	115.89	-71.50	AV
0.0385	0°	24.25	23.13	47.38	135.89	-88.51	PK
0.0661	0°	18.31	22.08	40.39	111.20	-70.81	AV
0.0661	0°	23.24	22.08	45.32	131.20	-85.88	PK
0.2658	0°	20.32	20.36	40.68	99.11	-58.43	AVG
0.2658	0°	22.79	20.36	43.15	119.11	-75.96	PK
1.4832	0°	27.23	19.55	46.78	64.18	-17.40	QP

Freq. (MHz)	Ant. 0°/90°	Reading(RA) (dBuV)	Corr.Factor(CF) (dB)	Measured(FS) (dBuV/m)	Limits(QP) (dBuV/m)	Margin (dB)	Note
0.0096	90°	19.21	24.30	43.51	127.94	-84.43	AVG
0.0096	90°	21.32	24.30	45.62	147.94	-102.32	PK
0.0224	90°	15.19	24.15	39.34	120.59	-81.25	AVG
0.0224	90°	17.23	24.15	41.38	140.59	-99.21	PK
0.0467	90°	18.05	22.61	40.66	114.23	-73.57	AVG
0.0467	90°	21.44	22.61	44.05	134.23	-90.18	PK
0.0776	90°	21.32	21.85	43.17	109.80	-66.64	AVG
0.0776	90°	22.89	21.85	44.74	129.80	-85.07	PK
0.3752	90°	21.23	20.10	41.33	96.12	-54.79	AVG
0.3752	90°	24.35	20.10	44.45	116.12	-71.67	PK
1.6966	90°	25.33	19.53	44.86	63.01	-18.15	QP

Remark:

- (1) The amplitude of spurious emissions which are attenuated by more than 20 dB below the permissible value has no need to be reported.
- (2) Distance extrapolation factor = 40 log (specific distance / test distance) (dB);
- (3) Limit line = specific limits (dBuV) + distance extrapolation factor.



4.2.8 TEST RESULTS (BETWEEN 30 – 1000 MHZ)

Remark:

- (1) Reading in which marked as QP or Peak means measurements by using are Quasi-Peak Mode or Peak Mode with Detector BW=120KHz ; SPA setting in RBW=120KHz, VBW =120KHz, Swp. Time = 0.3 sec./MHz.
- (2) All readings are Peak unless otherwise stated QP in column of 『Note』 . Peak denotes that the Peak reading compliance with the QP Limits and then QP Mode measurement didn't perform.
- (3) Measuring frequency range from 30MHz to 1000MHz.
- (4) If the peak scan value lower limit more than 20dB, then this signal data does not show in table.



Test Mode: TX B MODE CHANNEL 01

Vertical

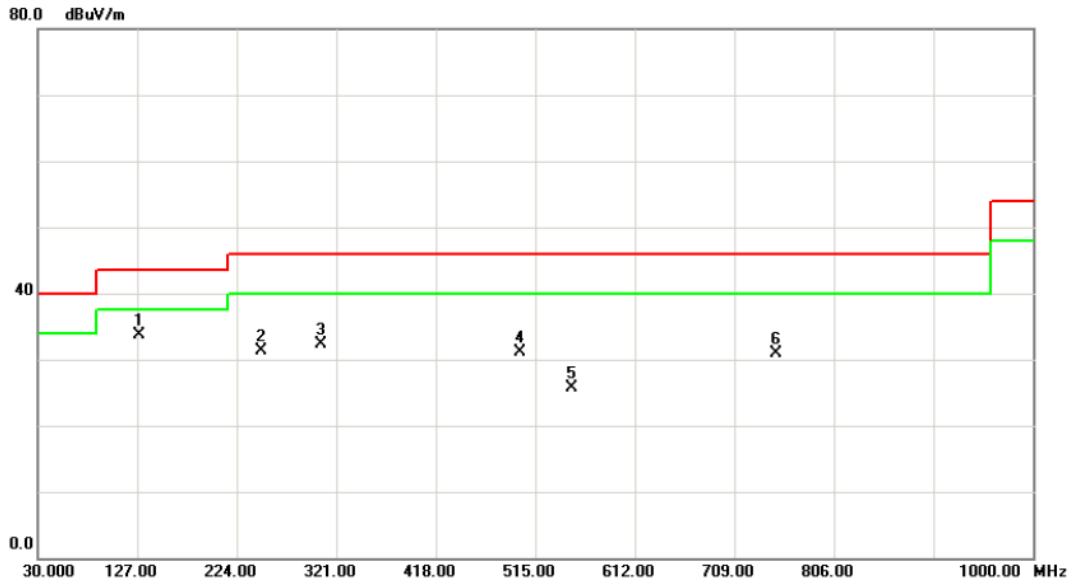

No.	Mk.	Freq. MHz	Reading Level dBuV	Correct Factor dB	Measure- ment dBuV/m	Limit dBuV/m	Over dB	Detector	Comment
1	*	128.9400	47.05	-13.39	33.66	43.50	-9.84	peak	
2		248.2500	46.22	-14.95	31.27	46.00	-14.73	peak	
3		306.4500	43.52	-11.27	32.25	46.00	-13.75	peak	
4		499.4800	41.44	-10.33	31.11	46.00	-14.89	peak	
5		549.9200	33.29	-7.65	25.64	46.00	-20.36	peak	
6		749.7400	35.76	-4.91	30.85	46.00	-15.15	peak	



Test Mode: TX B MODE CHANNEL 01

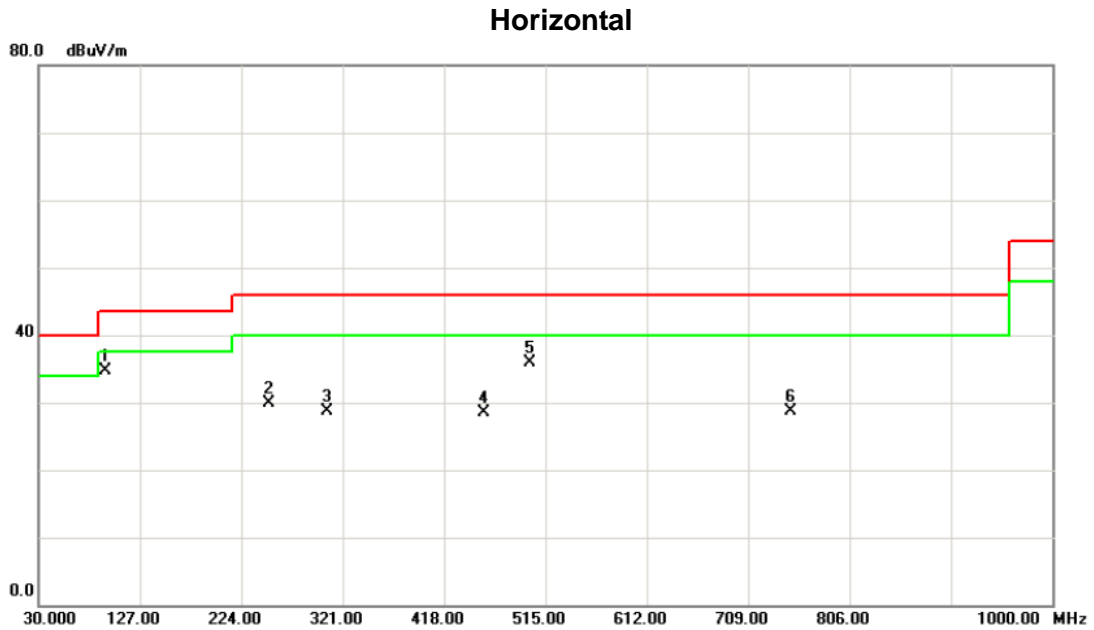

No.	Mk.	Freq. MHz	Reading Level dBuV	Correct Factor dB	Measure- ment dBuV/m	Limit dBuV/m	Over dB	Detector	Comment
1	*	94.0200	52.16	-17.43	34.73	43.50	-8.77	peak	
2		250.1900	44.94	-14.97	29.97	46.00	-16.03	peak	
3		306.4500	40.06	-11.27	28.79	46.00	-17.21	peak	
4		455.8300	37.52	-9.08	28.44	46.00	-17.56	peak	
5		500.4500	46.17	-10.31	35.86	46.00	-10.14	peak	
6		749.7400	33.64	-4.91	28.73	46.00	-17.27	peak	



Test Mode: TX B MODE CHANNEL 06

Vertical

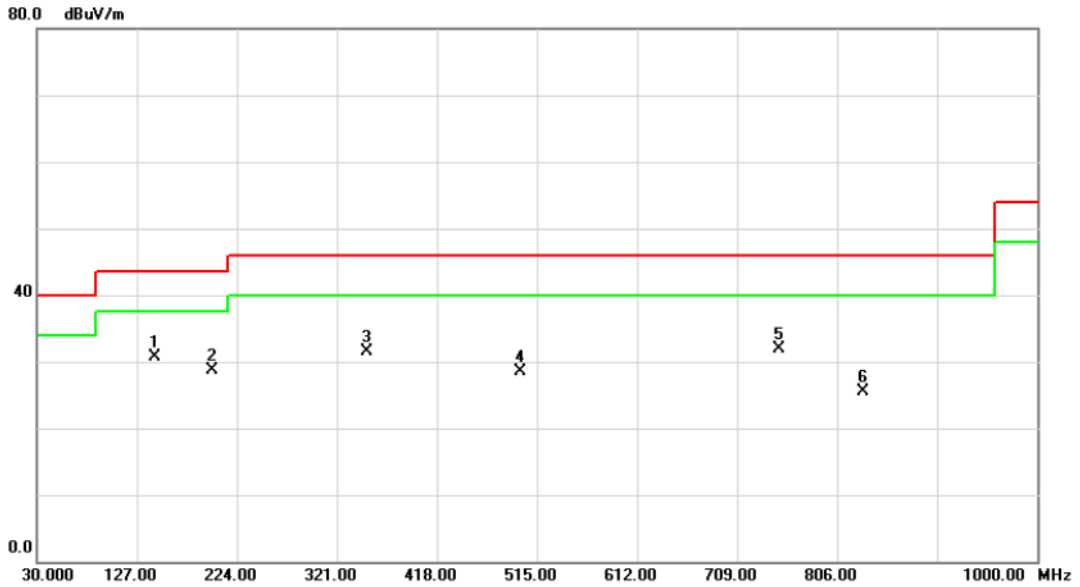

No.	Mk.	Freq. MHz	Reading Level dBuV	Correct Factor dB	Measure- ment dBuV/m	Limit dBuV/m	Over dB	Detector	Comment
1	*	144.4600	44.47	-13.76	30.71	43.50	-12.79	peak	
2		199.7500	43.87	-15.18	28.69	43.50	-14.81	peak	
3		350.1000	42.88	-11.46	31.42	46.00	-14.58	peak	
4		498.5100	38.79	-10.29	28.50	46.00	-17.50	peak	
5		749.7400	36.72	-4.91	31.81	46.00	-14.19	peak	
6		831.2200	29.01	-3.46	25.55	46.00	-20.45	peak	



Test Mode: TX B MODE CHANNEL 06

Horizontal

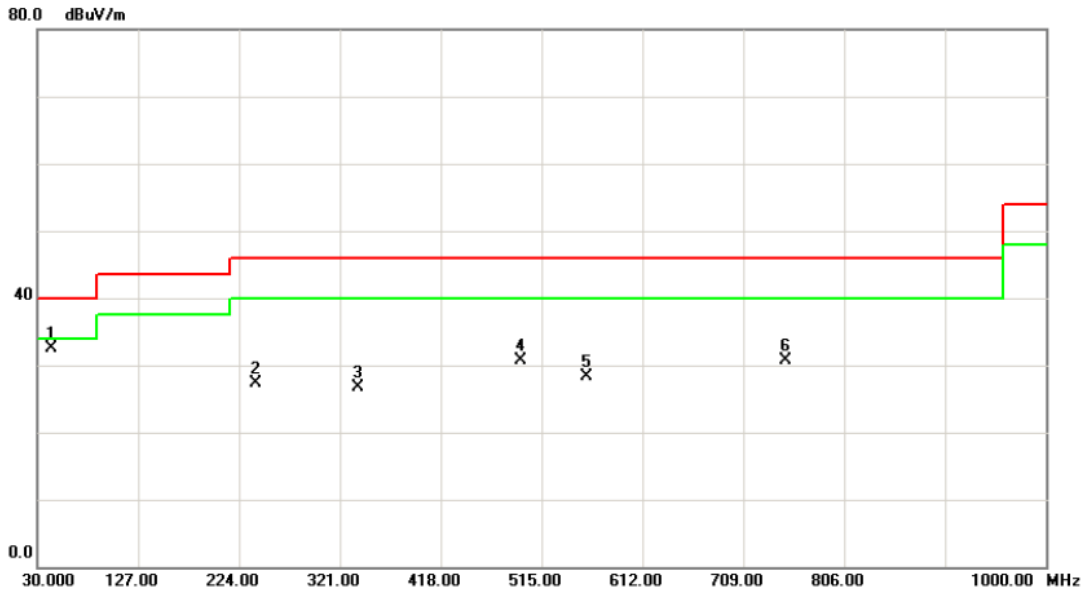

No.	Mk.	Freq. MHz	Reading Level dBuV	Correct Factor dB	Measure- ment dBuV/m	Limit dBuV/m	Over dB	Detector	Comment
1	*	43.5800	46.64	-14.22	32.42	40.00	-7.58	peak	
2		240.4900	42.05	-14.83	27.22	46.00	-18.78	peak	
3		338.4600	38.13	-11.41	26.72	46.00	-19.28	peak	
4		494.6300	40.91	-10.18	30.73	46.00	-15.27	peak	
5		558.6500	35.97	-7.72	28.25	46.00	-17.75	peak	
6		749.7400	35.60	-4.91	30.69	46.00	-15.31	peak	



Test Mode: TX B MODE CHANNEL 11

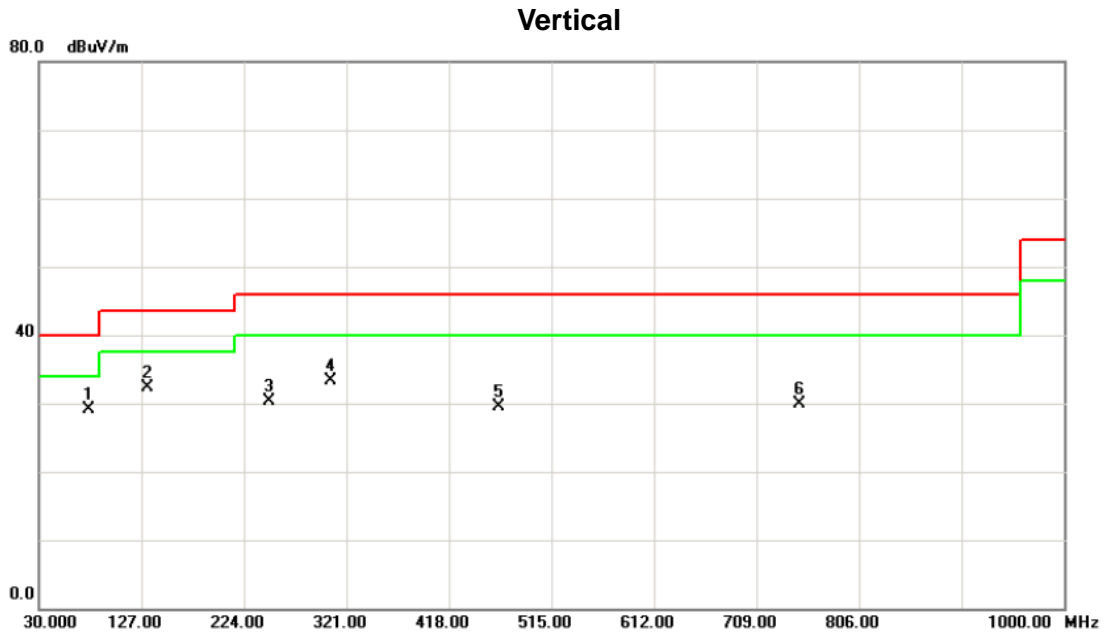

No.	Mk.	Freq. MHz	Reading Level dBuV	Correct Factor dB	Measure- ment dBuV/m	Limit dBuV/m	Over dB	Detector	Comment
1	*	77.5300	46.15	-17.13	29.02	40.00	-10.98	peak	
2		132.8200	45.68	-13.46	32.22	43.50	-11.28	peak	
3		248.2500	45.22	-14.95	30.27	46.00	-15.73	peak	
4		306.4500	44.52	-11.27	33.25	46.00	-12.75	peak	
5		464.5600	38.84	-9.33	29.51	46.00	-16.49	peak	
6		749.7400	34.77	-4.91	29.86	46.00	-16.14	peak	



Test Mode: TX B MODE CHANNEL 11

Horizontal

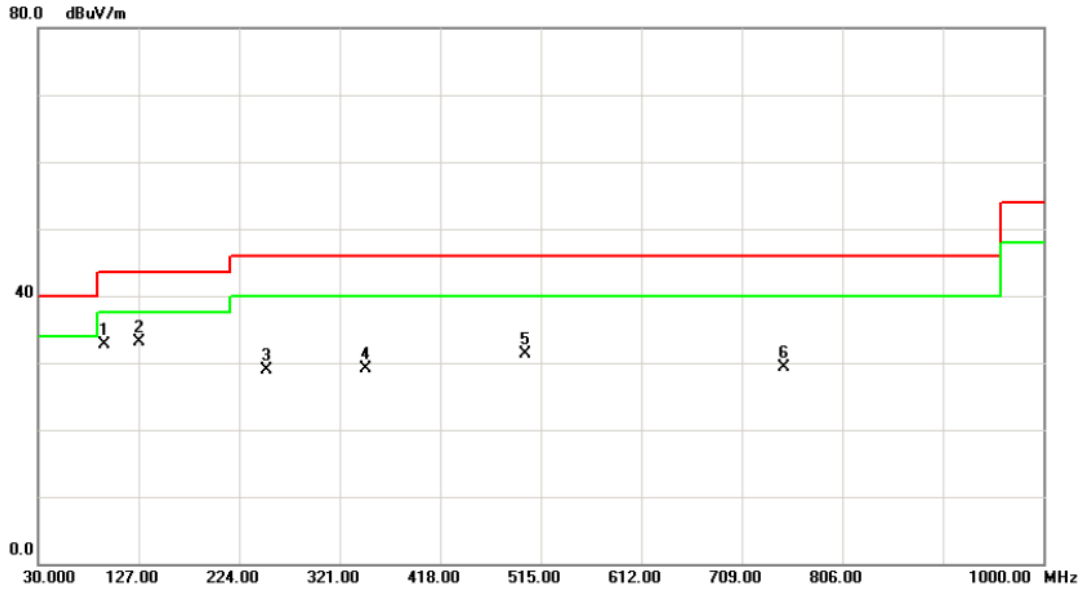

No.	Mk.	Freq. MHz	Reading Level dBuV	Correct Factor dB	Measure- ment dBuV/m	Limit dBuV/m	Over dB	Detector	Comment
1		94.0200	50.16	-17.43	32.73	43.50	-10.77	peak	
2	*	127.9700	46.56	-13.45	33.11	43.50	-10.39	peak	
3		250.1900	43.94	-14.97	28.97	46.00	-17.03	peak	
4		346.2200	40.63	-11.44	29.19	46.00	-16.81	peak	
5		499.4800	41.65	-10.33	31.32	46.00	-14.68	peak	
6		749.7400	34.14	-4.91	29.23	46.00	-16.77	peak	



4.2.9 TEST RESULTS (ABOVE 1000 MHZ)

Remark:

- (1) All readings are Peak unless otherwise stated QP in column of 『Note』 . Peak denotes that the Peak reading compliance with the QP Limits and then QP Mode measurement didn't perform.
- (2) Measuring frequency range from 30MHz to 1000MHz or the 10th harmonic of highest fundamental frequency. "F" denotes fundamental frequency; "H" denotes spurious frequency; "E" denotes band edge frequency. (This judgment method includes the Band Edge Requirement.)
- (3) Radiated emissions measured in frequency range above 1000MHz were made with an instrument using Peak detector mode and AV detector mode of the emission.
- (4) Data of measurement within this frequency range shown " * " in the table above means the reading of emissions are attenuated more than 20dB below the permissible limits or the field strength is too small to be measured.
- (5) A preamp and high pass filter were used for this test in order to provide sufficient measurement sensitivity.
- (6) EUT Orthogonal Axis:
"X" - denotes Laid on Table; "Y" - denotes Vertical Stand; "Z" - denotes Side Stand
- (7) During the measurements above 1 GHz it is taken care of that the EUT is always within the 3 dB cone of radiation BW of the used antenna



Neutron Engineering Inc.

Test Mode : TX B MODE 2412MHz

Freq. (MHz)	Ant. Pol. H/V	Reading (dBuV)		Ant./CF CF(dB)	Act. (dBuV/m)		Limit (dBuV/m)		Note
		Peak	AV		Peak	AV	Peak	AV	
2390.00	V	23.86	14.09	34.09	57.95	48.18	74.00	54.00	X/E
2411.70	V	71.06	69.08	34.16	105.22	103.24			X/F
4824.03	V	46.38	43.87	6.43	52.81	50.30	74.00	54.00	X/H

Freq. (MHz)	Ant. Pol. H/V	Reading (dBuV)		Ant./CF CF(dB)	Act. (dBuV/m)		Limit (dBuV/m)		Note
		Peak	AV		Peak	AV	Peak	AV	
2390.00	H	23.18	13.71	34.09	57.27	47.80	74.00	54.00	X/E
2411.60	H	64.41	62.45	34.16	98.57	96.61			X/F
4824.04	H	41.09	35.25	6.43	47.52	41.68	74.00	54.00	X/H



TX CH01 (Above 1000 MHz, Vertical)

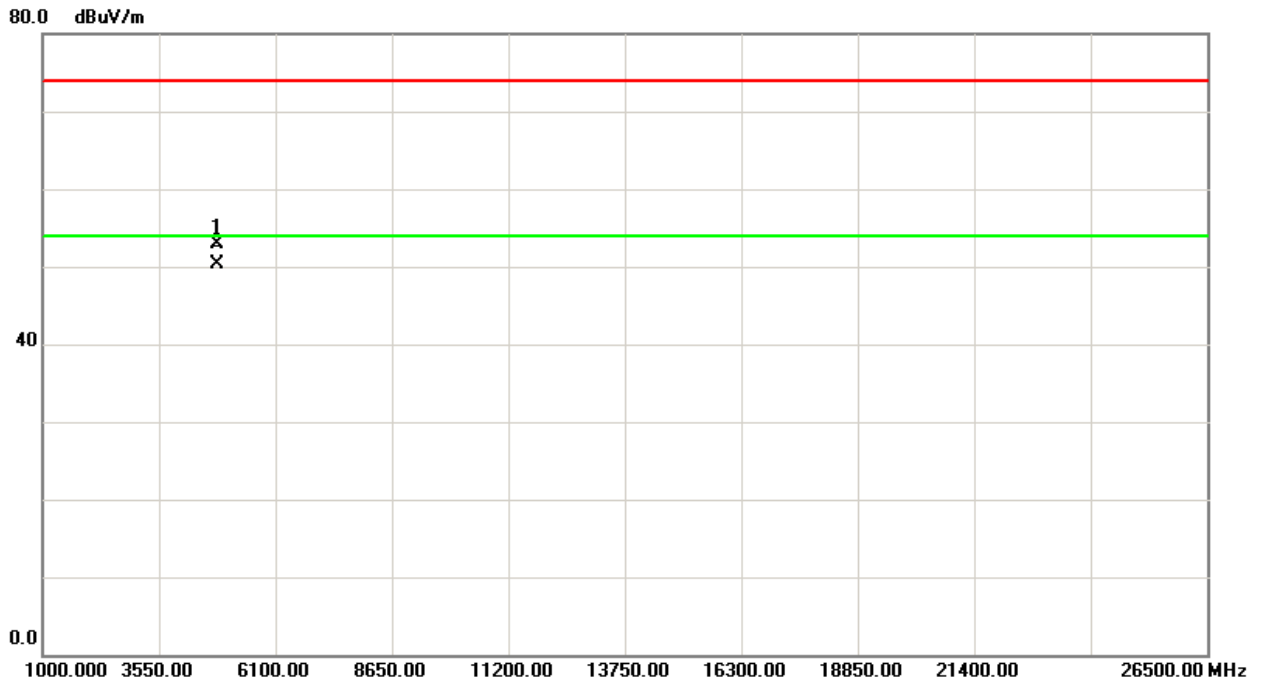
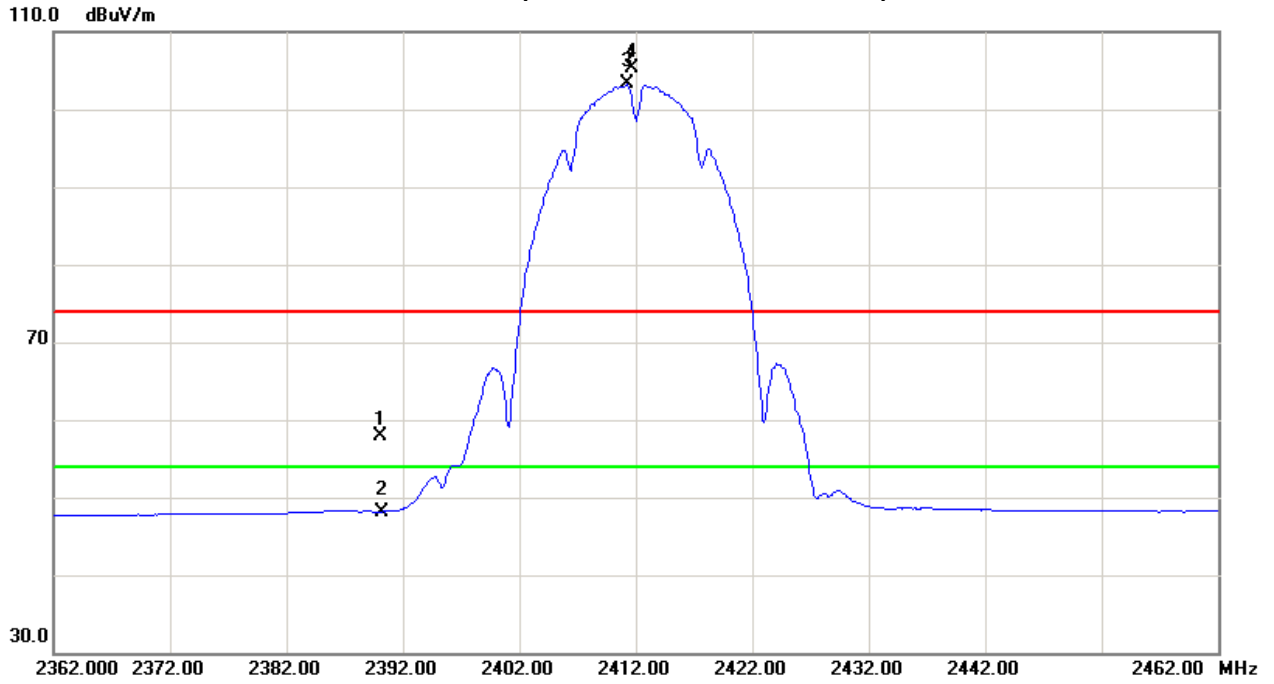



TX CH01 (Above 1000 MHz, Horizontal)

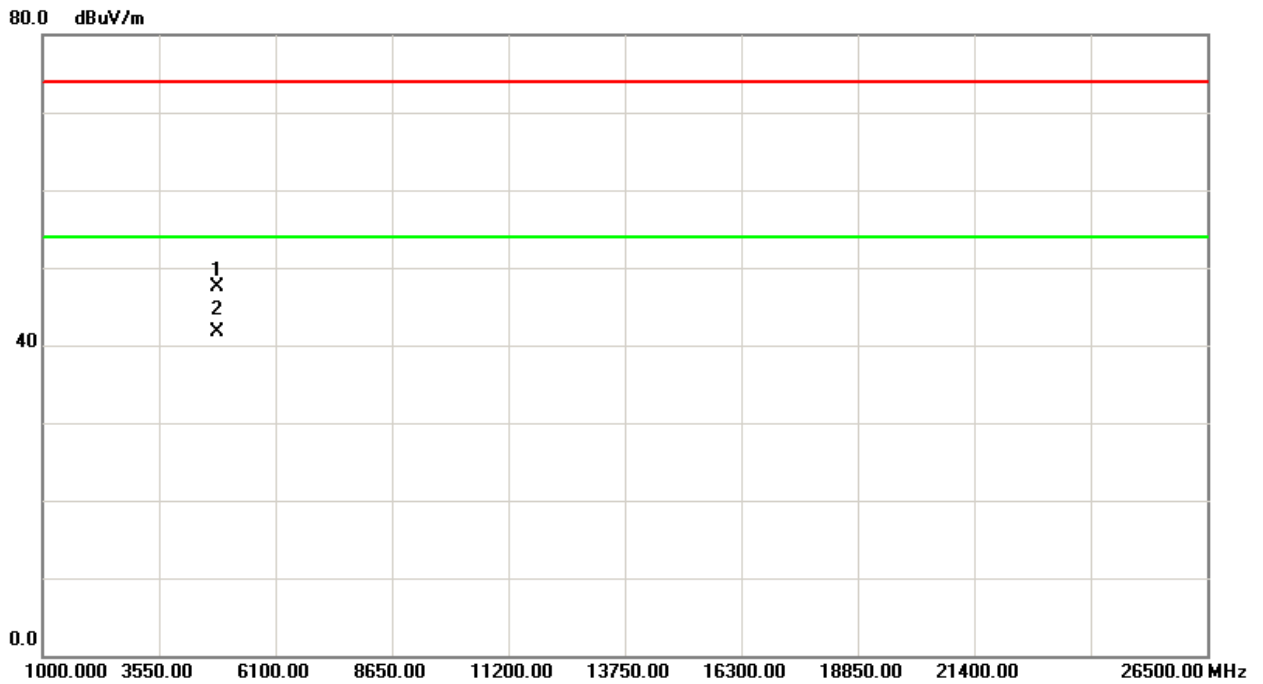
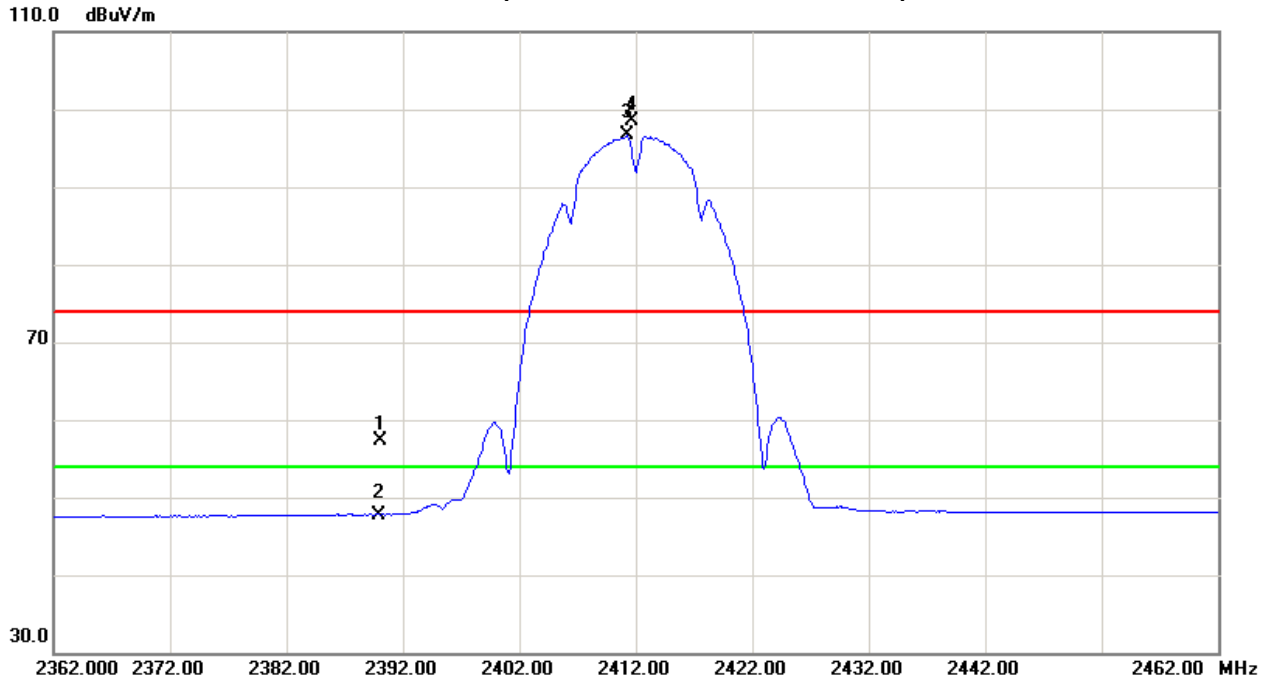



Test Mode : TX B MODE 2437MHz

Freq. (MHz)	Ant.Pol.	Reading		Ant./CF CF(dB)	Act.		Limit		Note
		Peak (dBuV)	AV (dBuV)		Peak (dBuV/m)	AV (dBuV/m)	Peak (dBuV/m)	AV (dBuV/m)	
2436.20	V	72.61	70.77	34.23	106.84	105.00			X/F
4874.02	V	42.31	37.60	6.58	48.89	44.18	74.00	54.00	X/H

Freq. (MHz)	Ant.Pol.	Reading		Ant./CF CF(dB)	Act.		Limit		Note
		Peak (dBuV)	AV (dBuV)		Peak (dBuV/m)	AV (dBuV/m)	Peak (dBuV/m)	AV (dBuV/m)	
2436.00	H	65.72	63.80	34.23	99.95	98.03			X/F
4874.03	H	47.38	45.08	6.58	53.96	51.66	74.00	54.00	X/H



TX CH06 (Above 1000 MHz, Vertical)

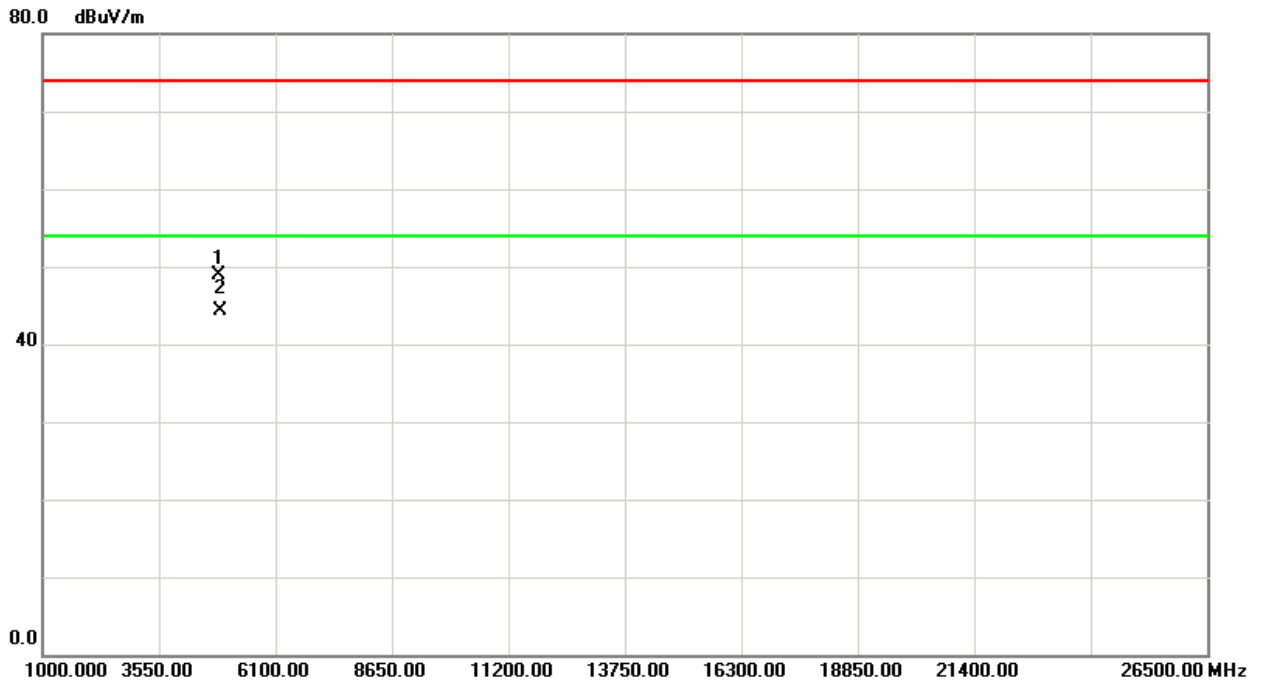
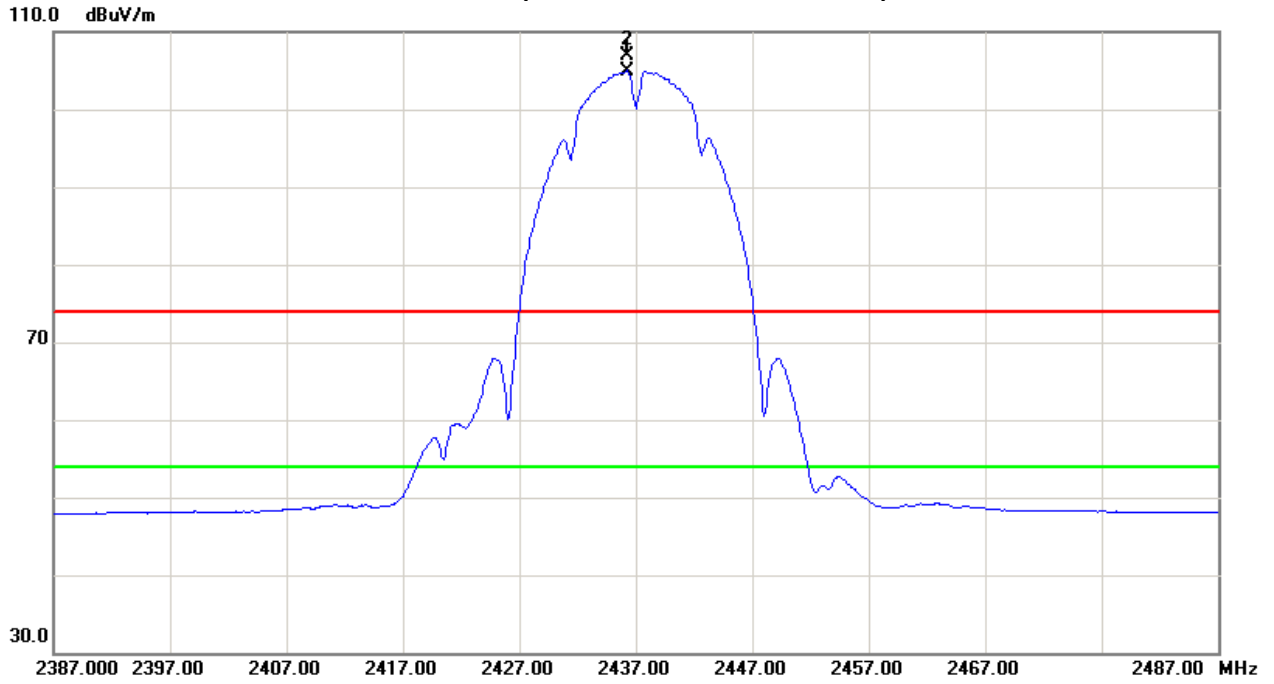



TX CH06 (Above 1000 MHz, Horizontal)

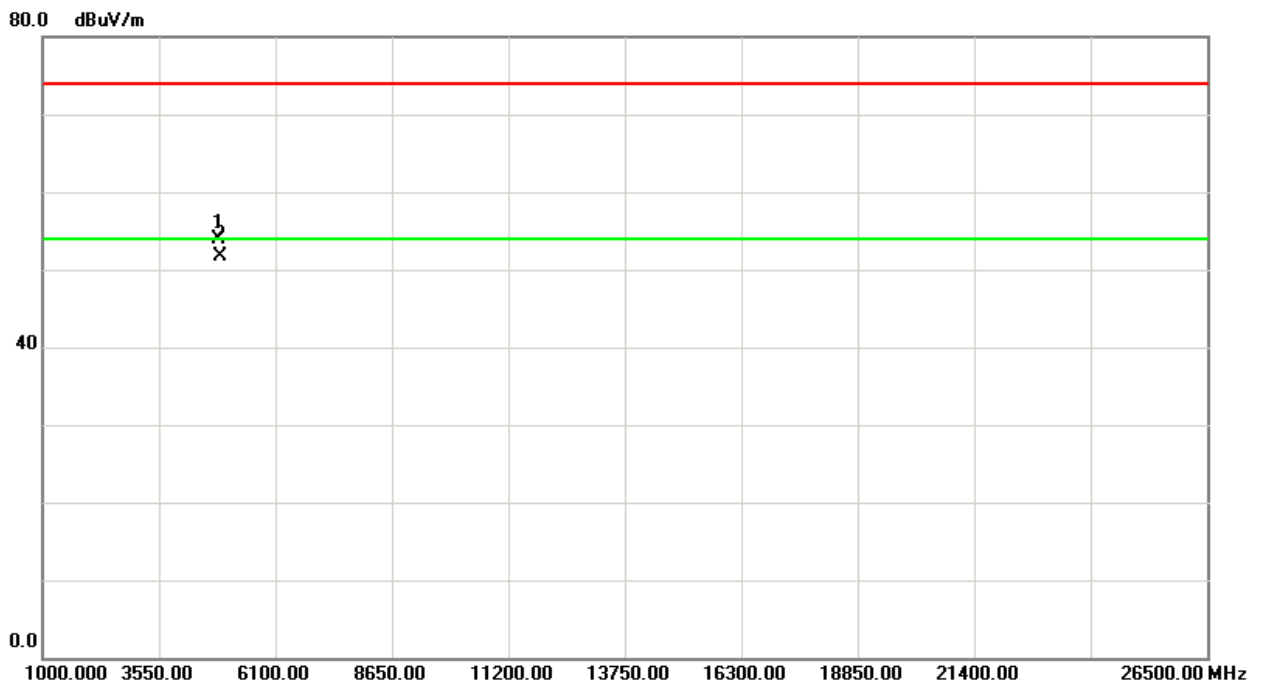
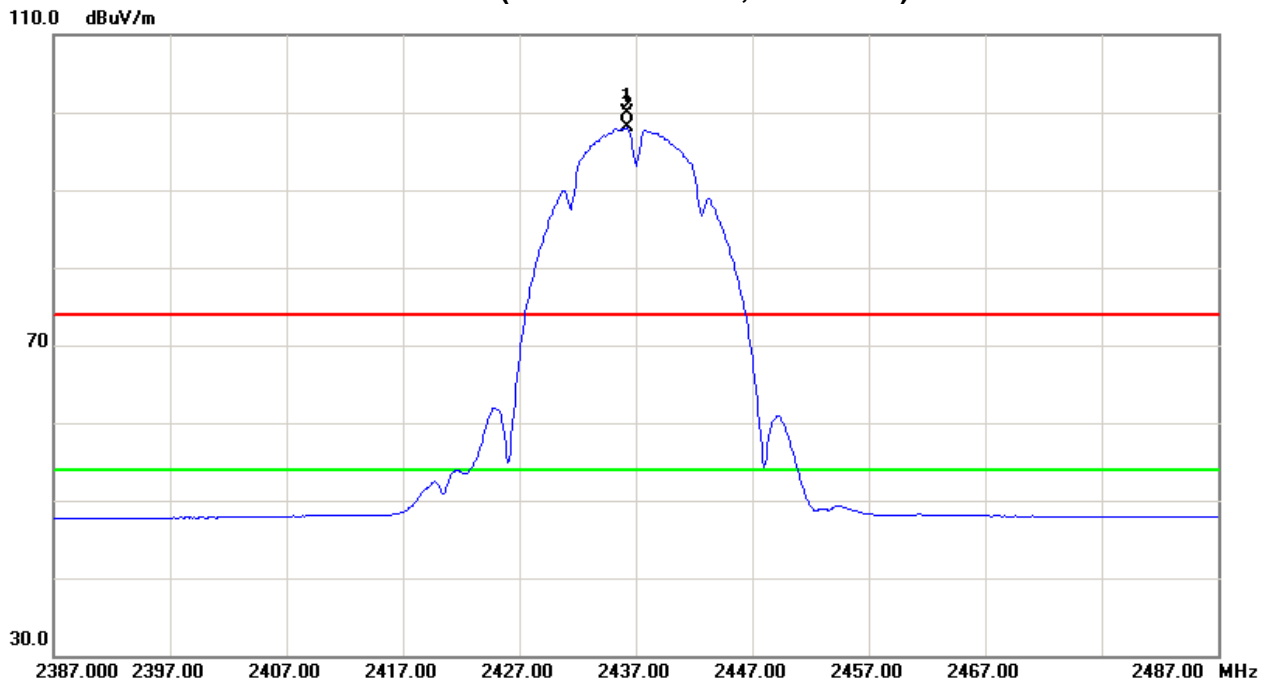



Test Mode : TX B MODE 2462MHz

Freq. (MHz)	Ant.Pol. H/V	Reading (dBuV)		Ant./CF CF(dB)	Act. (dBuV/m)		Limit (dBuV/m)		Note
		Peak	AV		Peak	AV	Peak	AV	
2461.20	V	69.75	67.91	34.31	104.06	102.22			X/F
2483.50	V	23.38	13.97	34.37	57.75	48.34	74.00	54.00	X/E
4924.03	V	45.72	42.99	6.72	52.44	49.71	74.00	54.00	X/H

Freq. (MHz)	Ant.Pol. H/V	Reading (dBuV)		Ant./CF CF(dB)	Act. (dBuV/m)		Limit (dBuV/m)		Note
		Peak	AV		Peak	AV	Peak	AV	
2461.10	H	61.75	59.71	34.31	96.06	94.02			X/F
2483.50	H	23.14	13.64	34.37	57.51	48.01	74.00	54.00	X/E
4924.03	H	42.67	37.88	6.72	49.39	44.60	74.00	54.00	X/H



TX CH11 (Above 1000 MHz, Vertical)

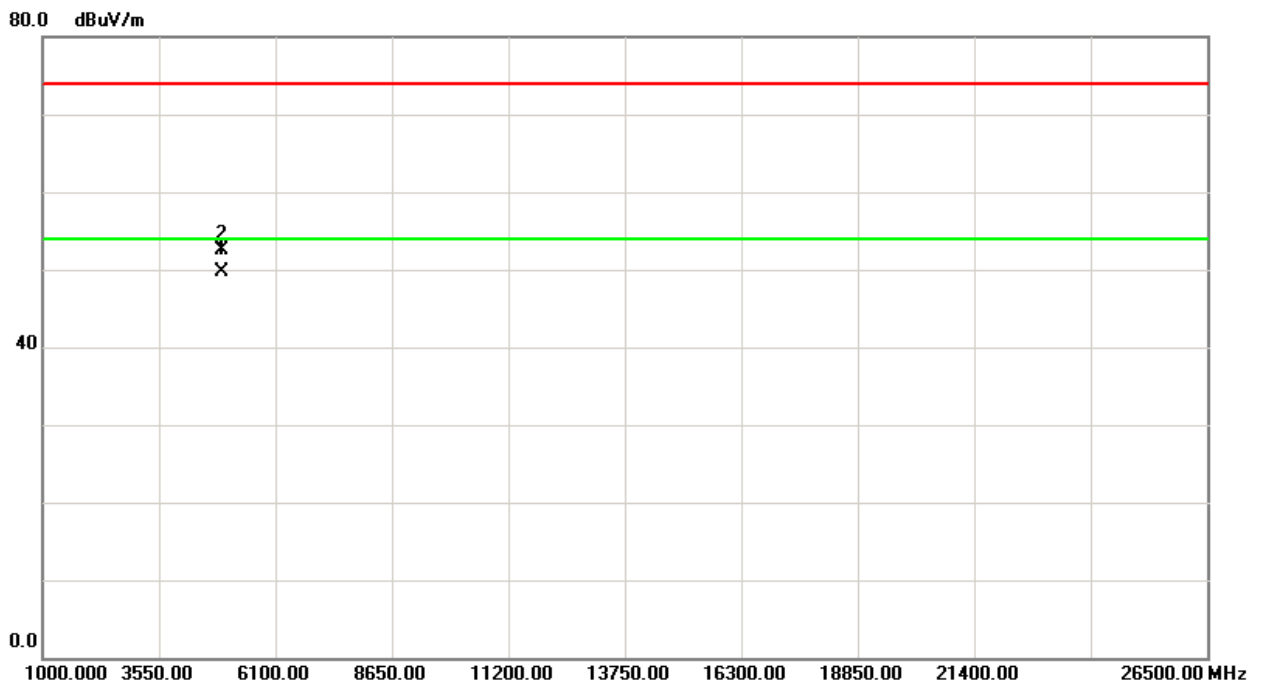
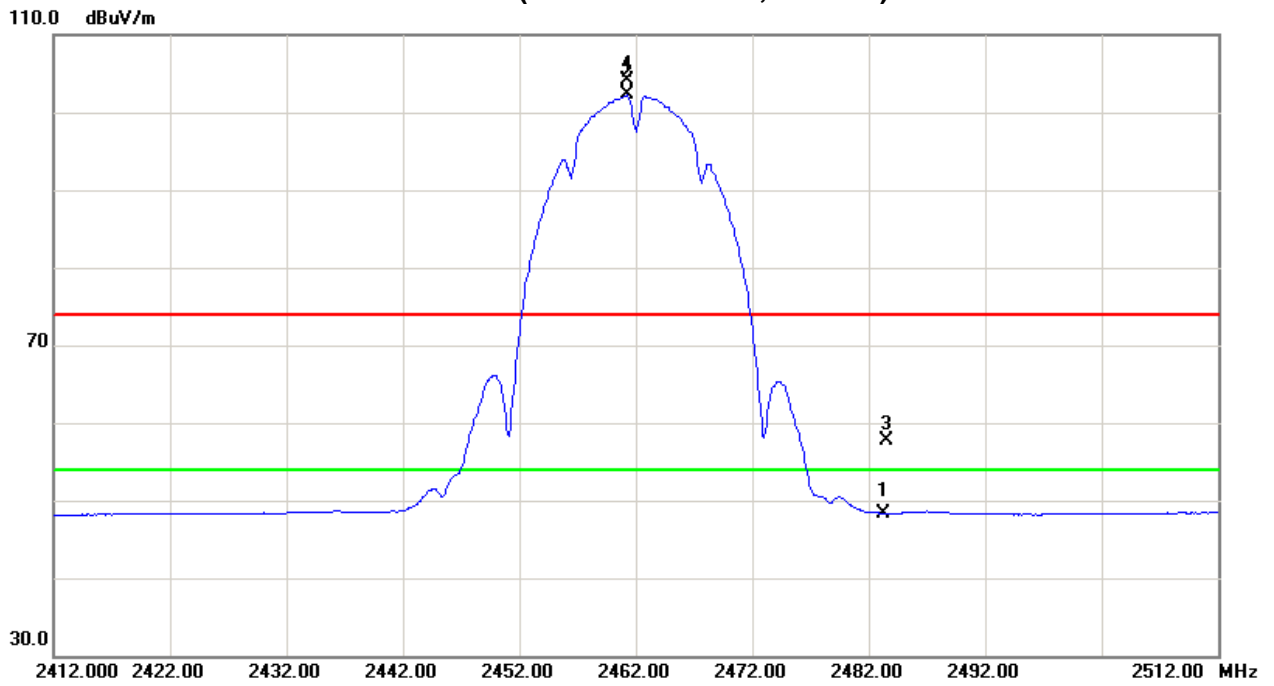



TX CH11 (Above 1000 MHz, Horizontal)

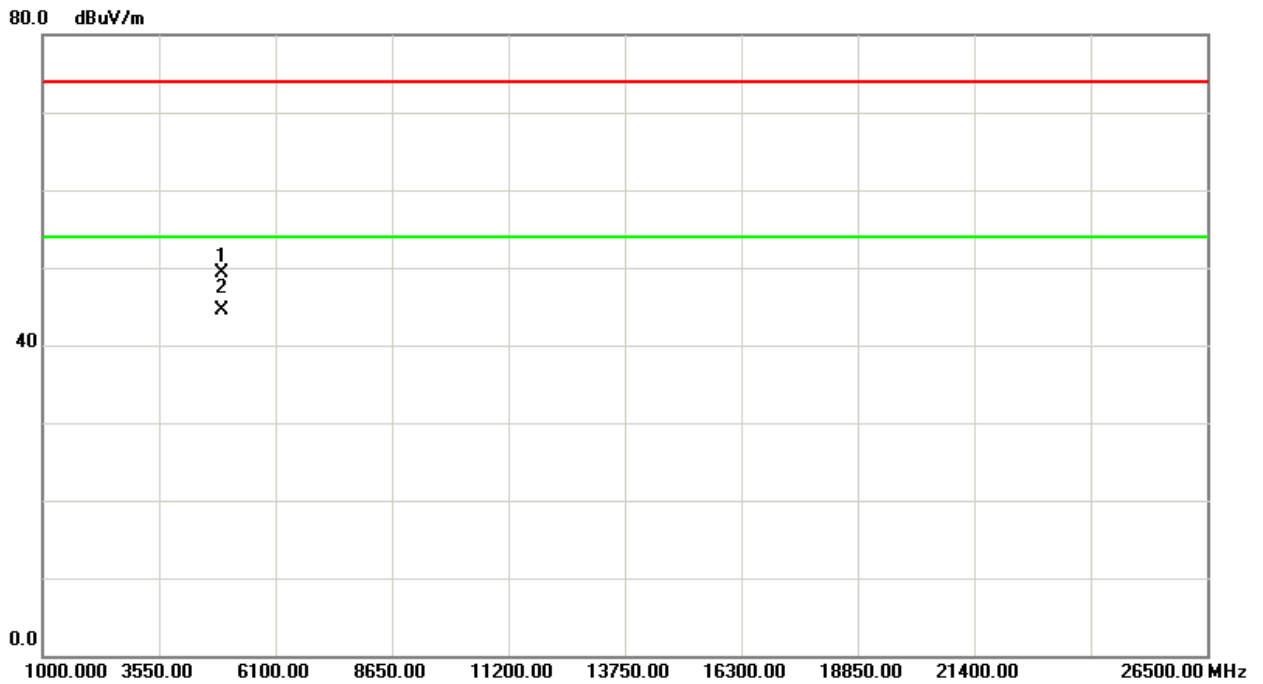
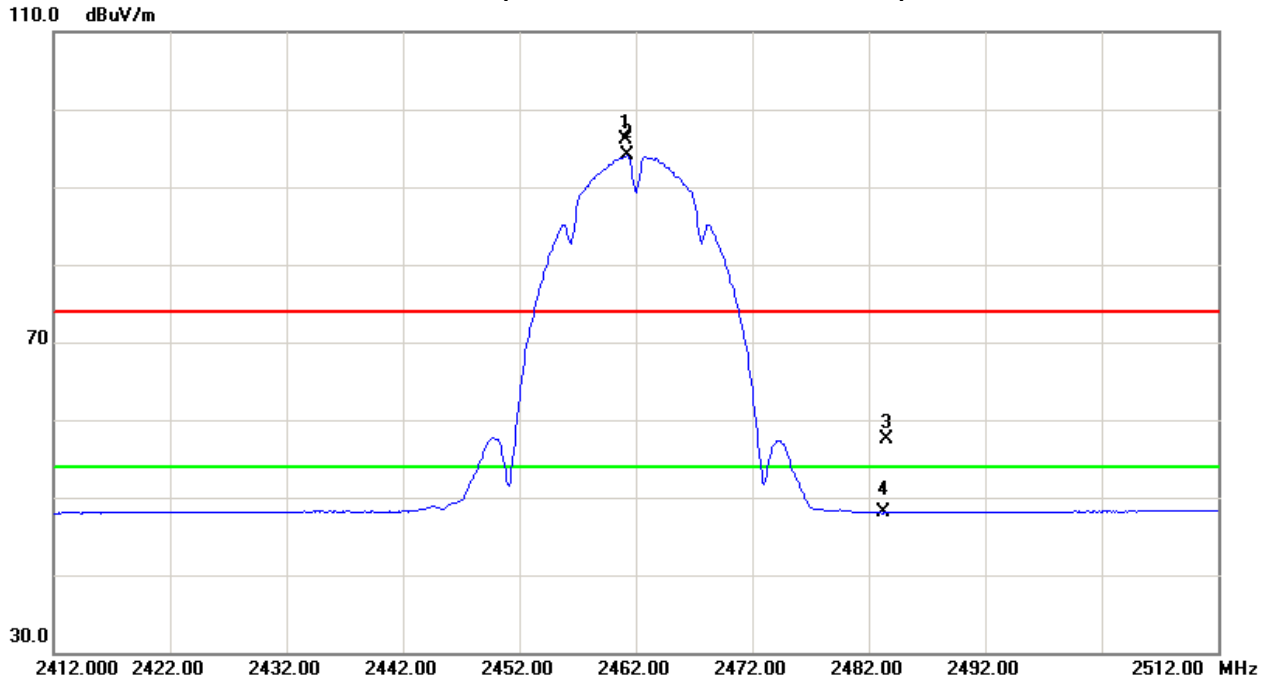



Test Mode : TX G MODE 2412MHz

Freq. (MHz)	Ant.Pol. H/V	Reading		Ant./CF CF(dB)	Act.		Limit		Note
		Peak (dBuV)	AV (dBuV)		Peak (dBuV/m)	AV (dBuV/m)	Peak (dBuV/m)	AV (dBuV/m)	
2390.00	V	24.28	14.26	34.09	58.37	48.35	74.00	54.00	X/E
2414.30	V	66.06	60.22	34.16	100.22	94.38			X/F
4824.15	V	41.35	32.20	6.43	47.78	38.63	74.00	54.00	X/H

Freq. (MHz)	Ant.Pol. H/V	Reading		Ant./CF CF(dB)	Act.		Limit		Note
		Peak (dBuV)	AV (dBuV)		Peak (dBuV/m)	AV (dBuV/m)	Peak (dBuV/m)	AV (dBuV/m)	
2390.00	H	23.11	13.97	34.09	57.20	48.06	74.00	54.00	X/E
2413.80	H	65.39	56.79	34.16	99.55	90.95			X/F
4824.00	H	37.55	28.35	6.43	43.98	34.78	74.00	54.00	X/H



TX CH01 (Above 1000 MHz, Vertical)

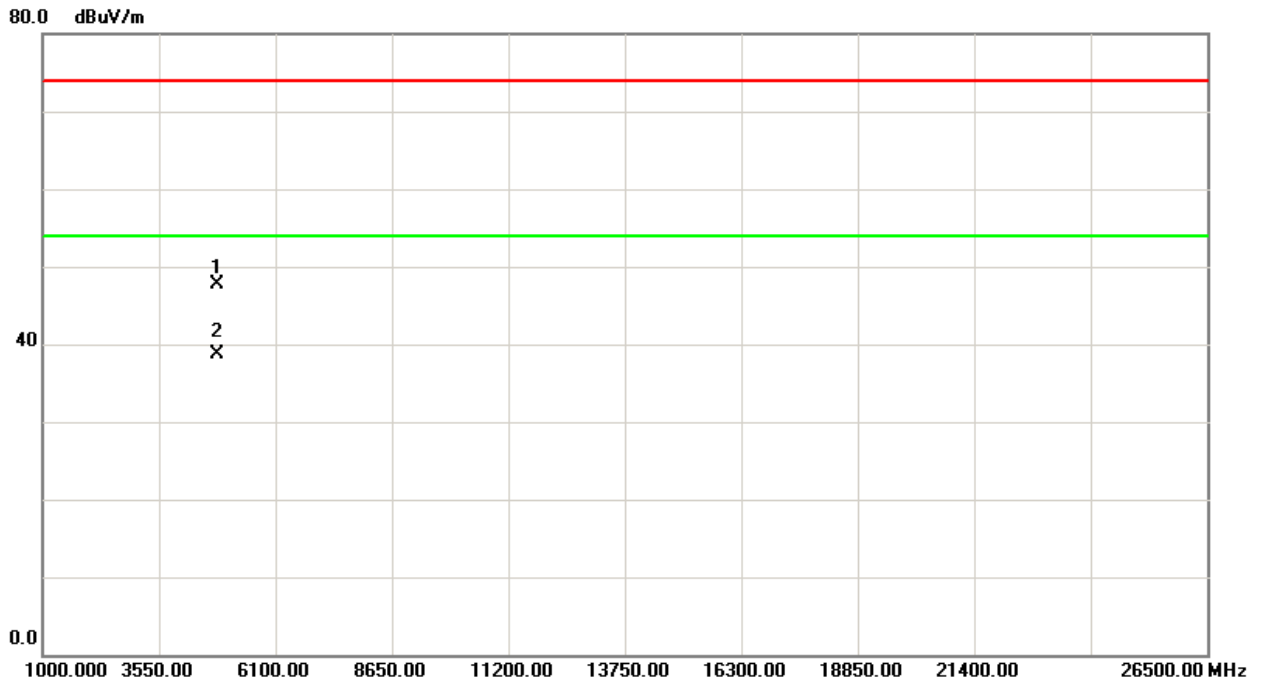
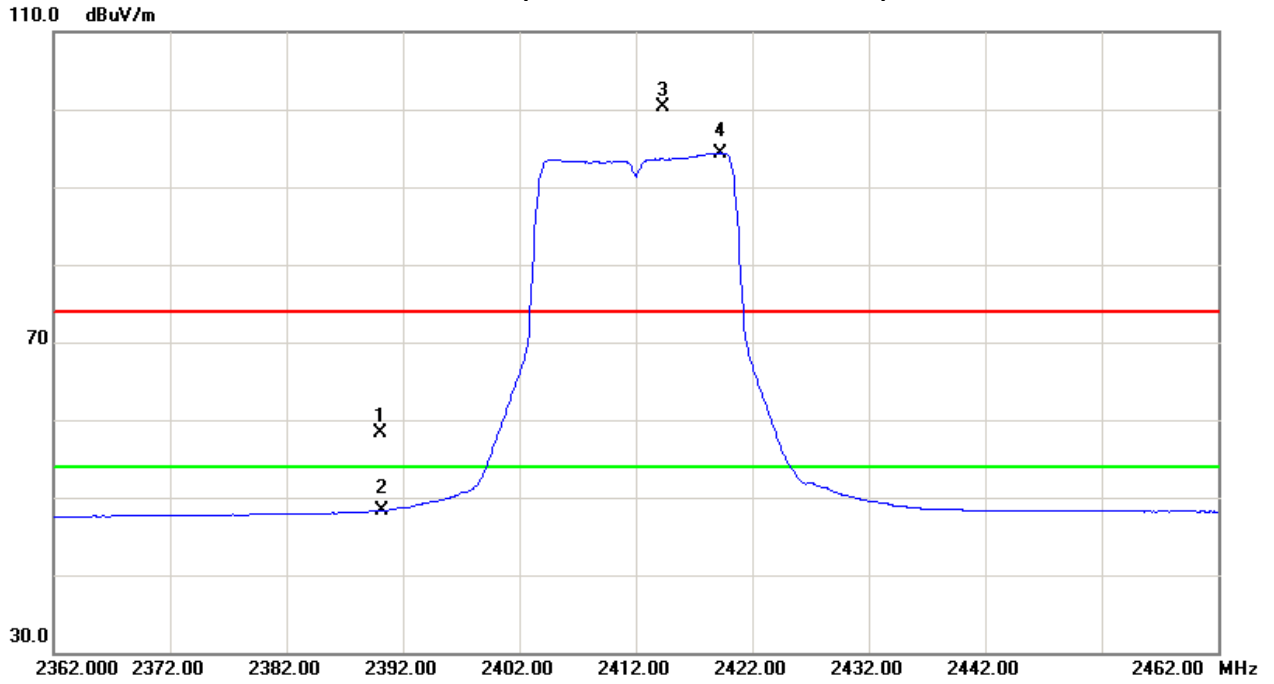



TX CH01 (Above 1000 MHz, Horizontal)

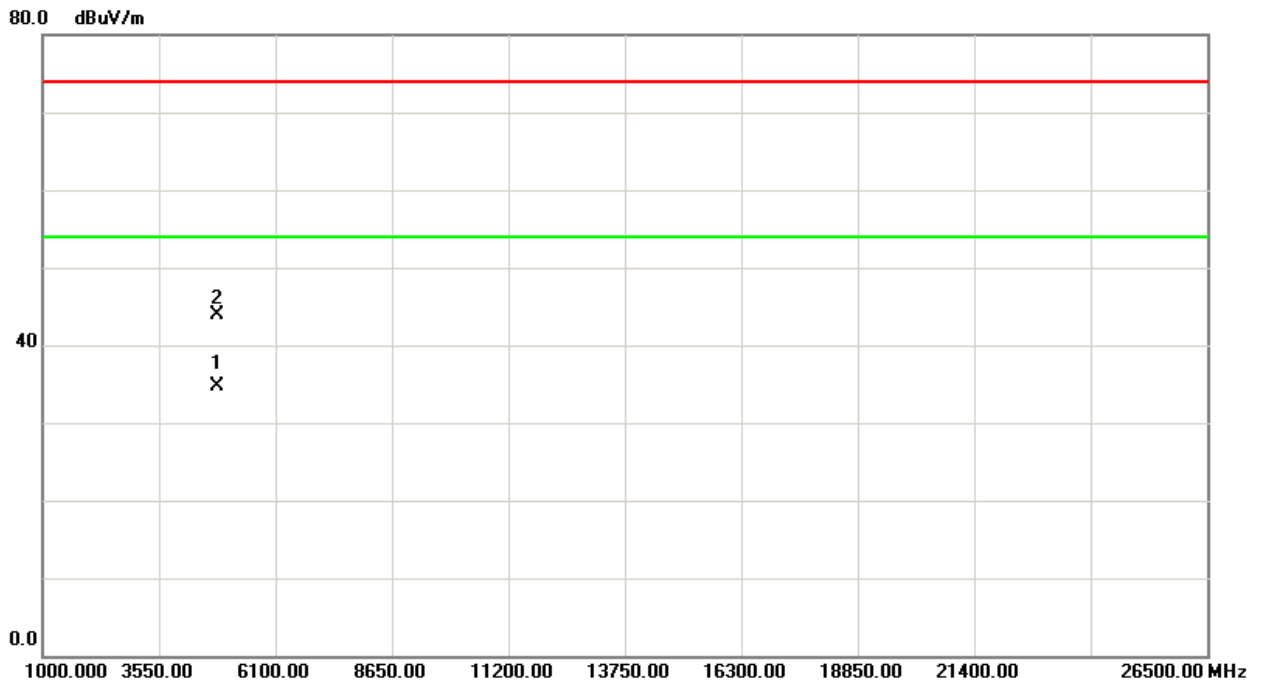
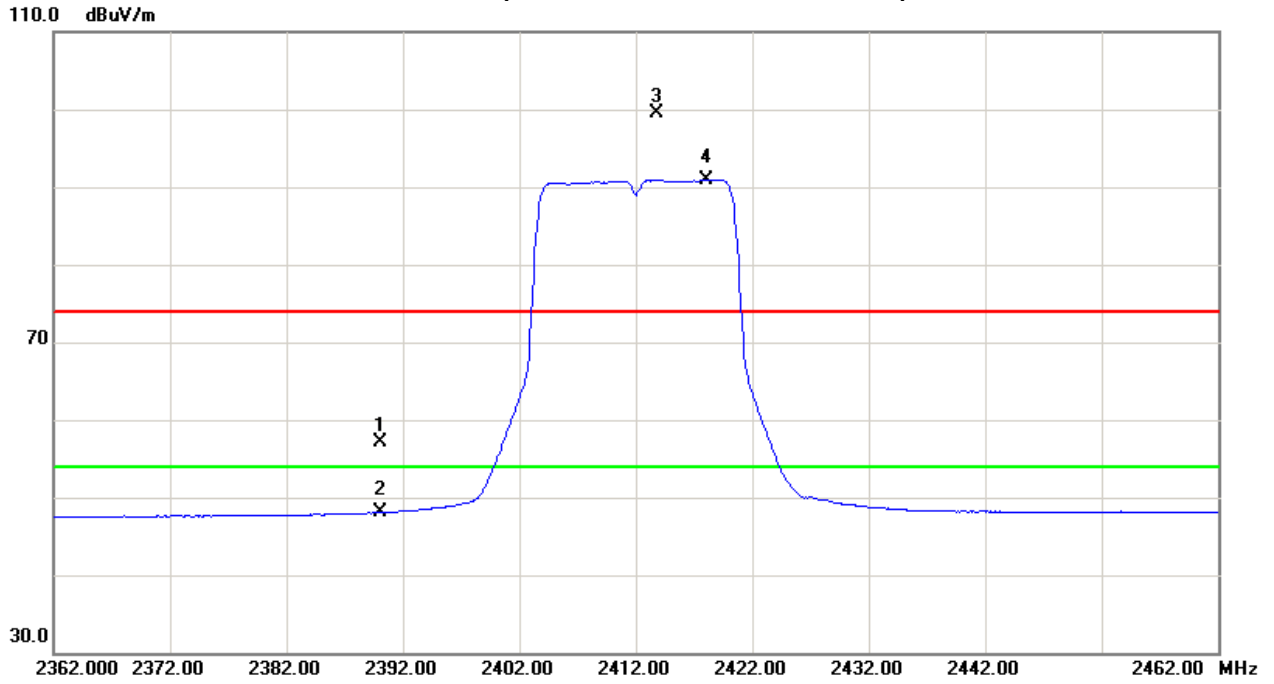



Test Mode : TX G MODE 2437MHz

Freq. (MHz)	Ant.Pol. H/V	Reading		Ant./CF CF(dB)	Act.		Limit		Note
		Peak (dBuV)	AV (dBuV)		Peak (dBuV/m)	AV (dBuV/m)	Peak (dBuV/m)	AV (dBuV/m)	
2443.50	V	74.39	67.04	34.25	108.64	101.29			X/F
4874.00	V	36.54	27.33	6.58	43.12	33.91	74.00	54.00	X/H

Freq. (MHz)	Ant.Pol. H/V	Reading		Ant./CF CF(dB)	Act.		Limit		Note
		Peak (dBuV)	AV (dBuV)		Peak (dBuV/m)	AV (dBuV/m)	Peak (dBuV/m)	AV (dBuV/m)	
2429.80	H	67.80	60.81	34.21	102.01	95.02			X/F
4874.09	H	40.98	32.35	6.58	47.56	38.93	74.00	54.00	X/H



TX CH06 (Above 1000 MHz, Vertical)

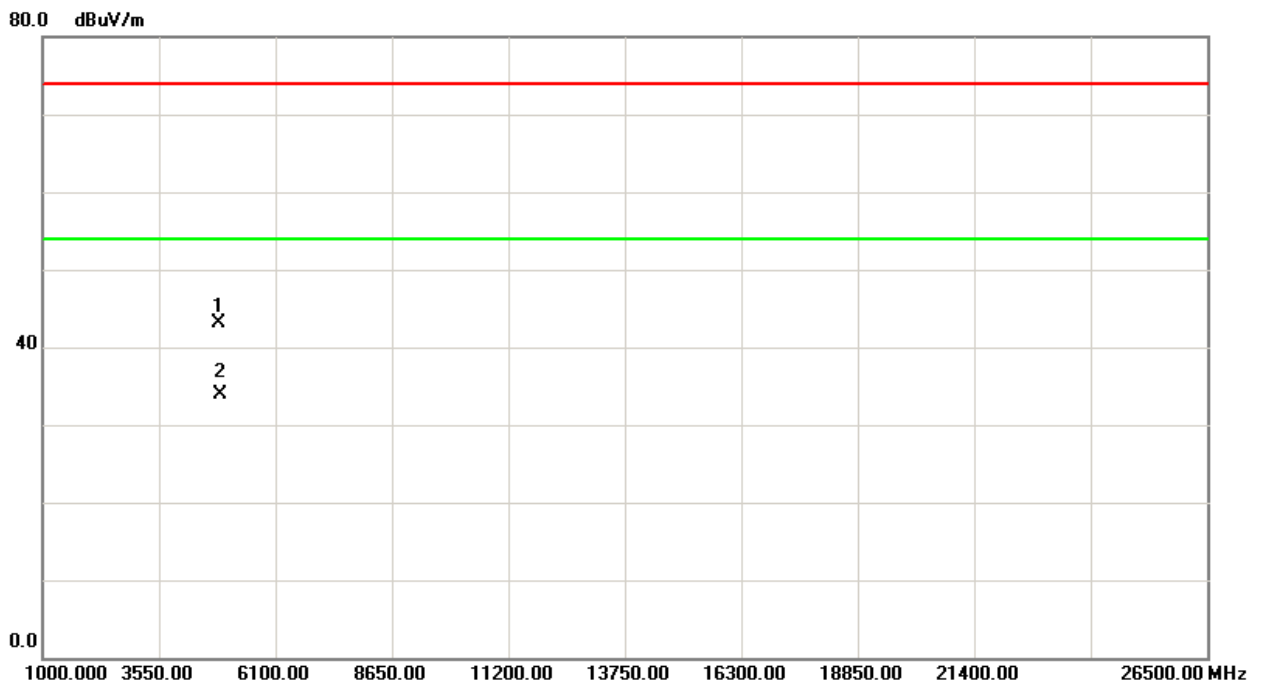
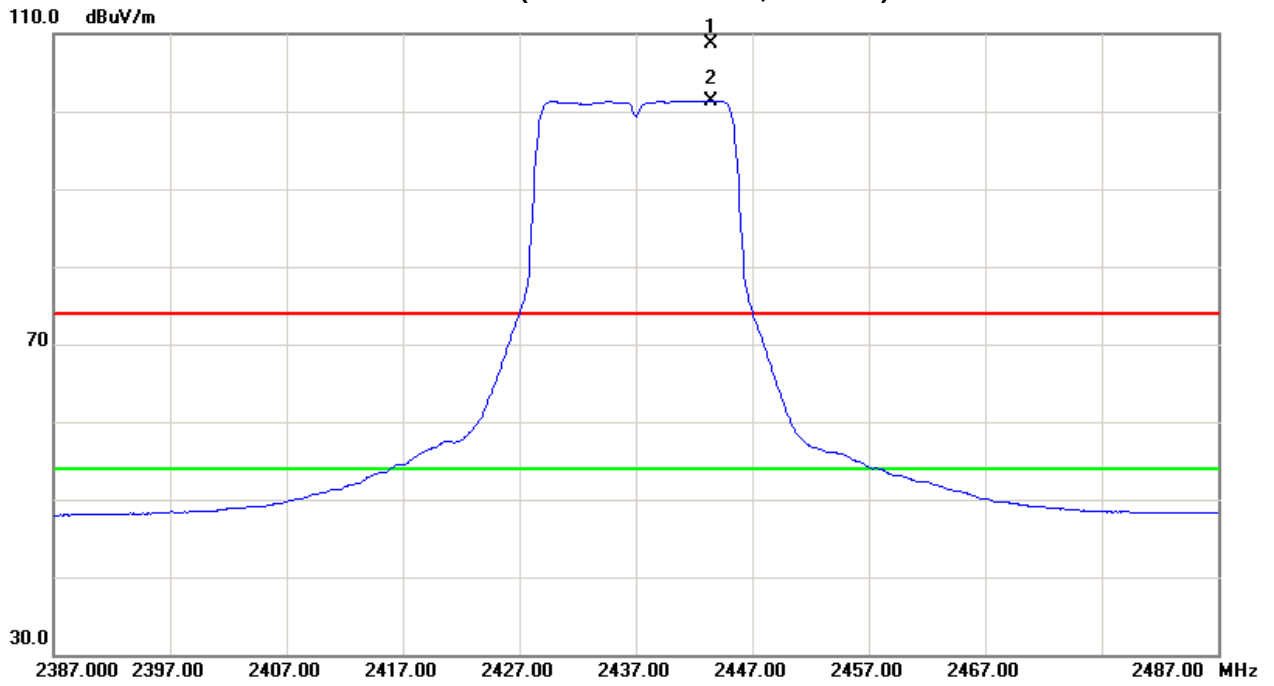



TX CH06 (Above 1000 MHz, Horizontal)

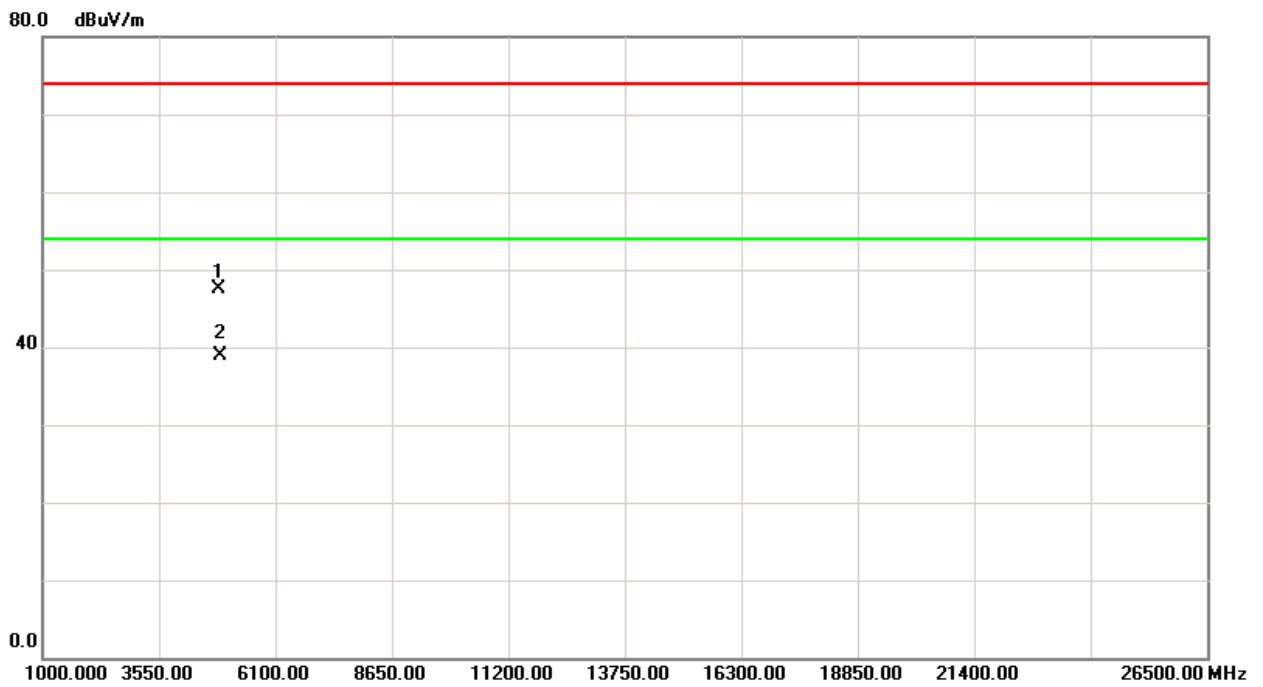
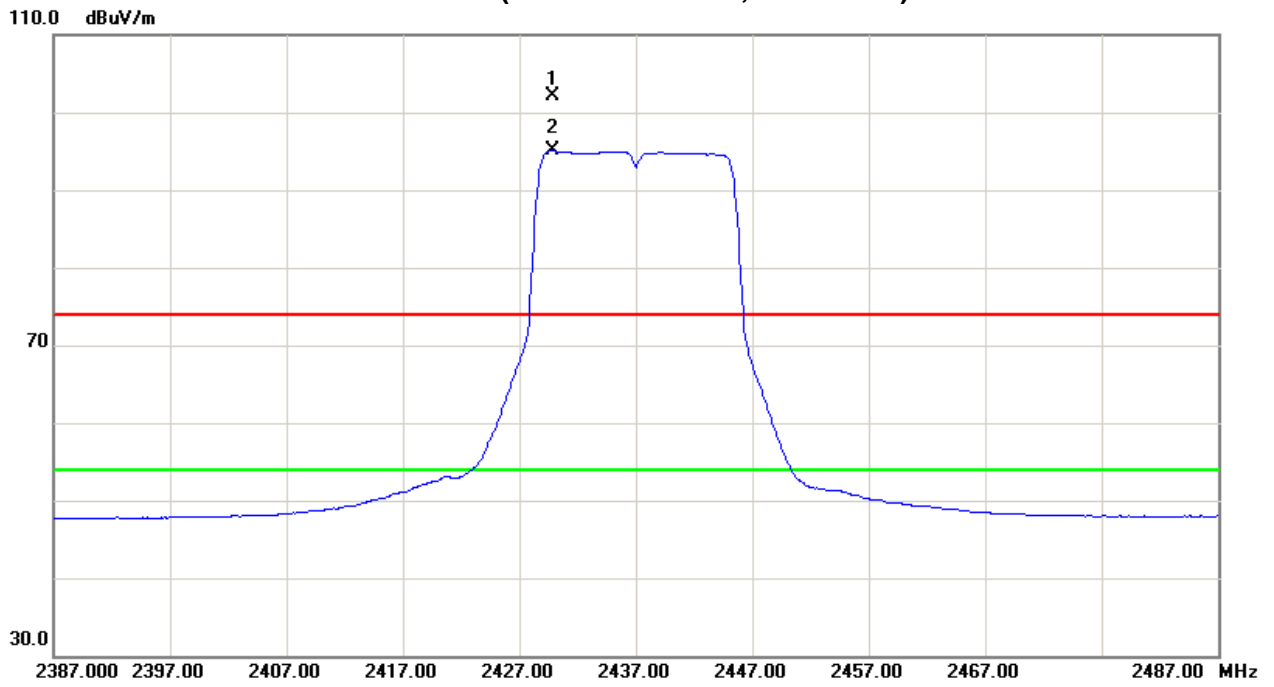



Neutron Engineering Inc.

Test Mode : TX G MODE 2462MHz

Freq. (MHz)	Ant.Pol. H/V	Reading		Ant./CF CF(dB)	Act.		Limit		Note
		Peak (dBuV)	AV (dBuV)		Peak (dBuV/m)	AV (dBuV/m)	Peak (dBuV/m)	AV (dBuV/m)	
2463.80	V	69.33	60.94	34.31	103.64	95.25			X/F
2483.50	V	26.26	15.00	34.37	60.63	49.37	74.00	54.00	X/E
4924.01	V	39.95	30.63	6.72	46.67	37.35	74.00	54.00	X/H

Freq. (MHz)	Ant.Pol. H/V	Reading		Ant./CF CF(dB)	Act.		Limit		Note
		Peak (dBuV)	AV (dBuV)		Peak (dBuV/m)	AV (dBuV/m)	Peak (dBuV/m)	AV (dBuV/m)	
2463.80	H	63.21	55.29	34.31	97.52	89.60			X/F
2483.50	H	24.57	13.74	34.37	58.94	48.11	74.00	54.00	X/E
4924.00	H	36.31	26.94	6.72	43.03	33.66	74.00	54.00	X/H



TX CH11 (Above 1000 MHz, Vertical)

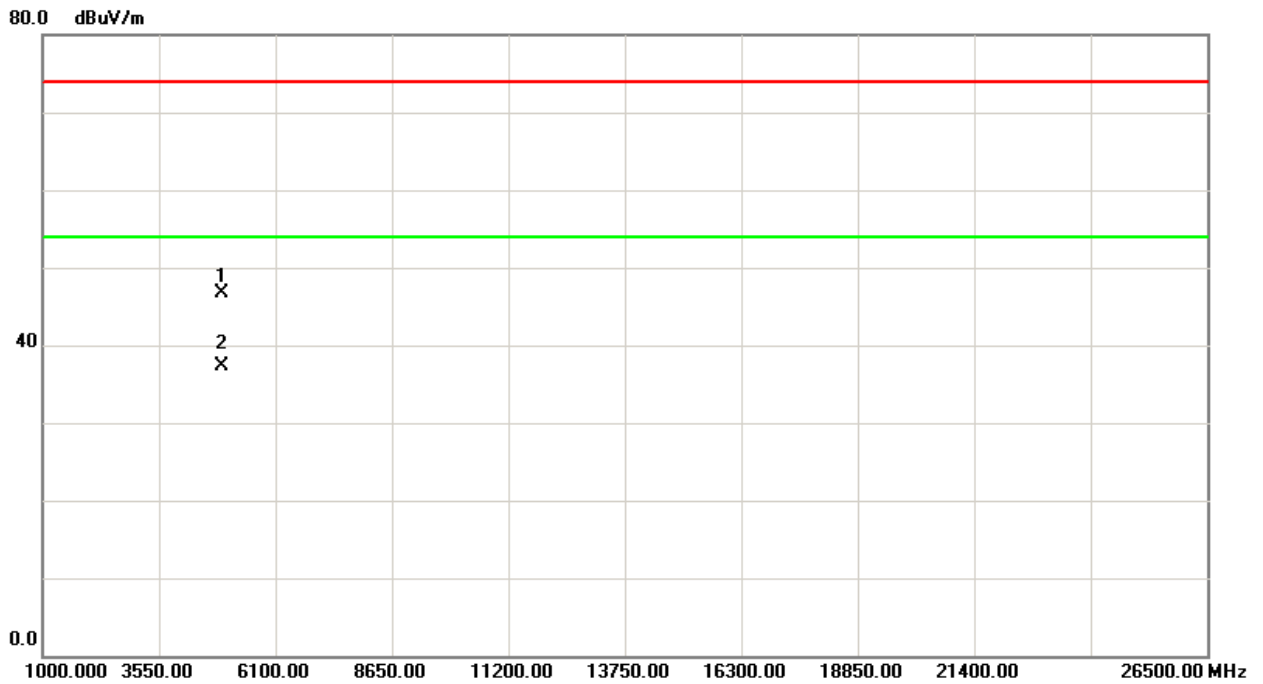
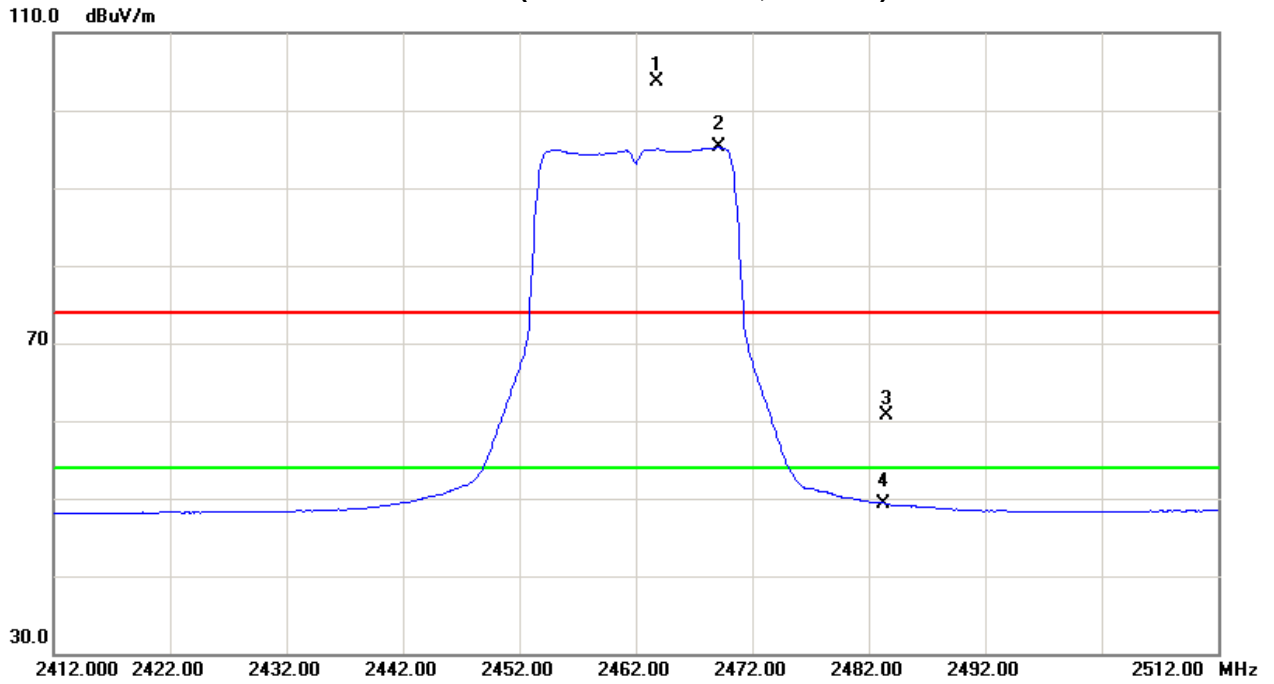



TX CH11 (Above 1000 MHz, Horizontal)

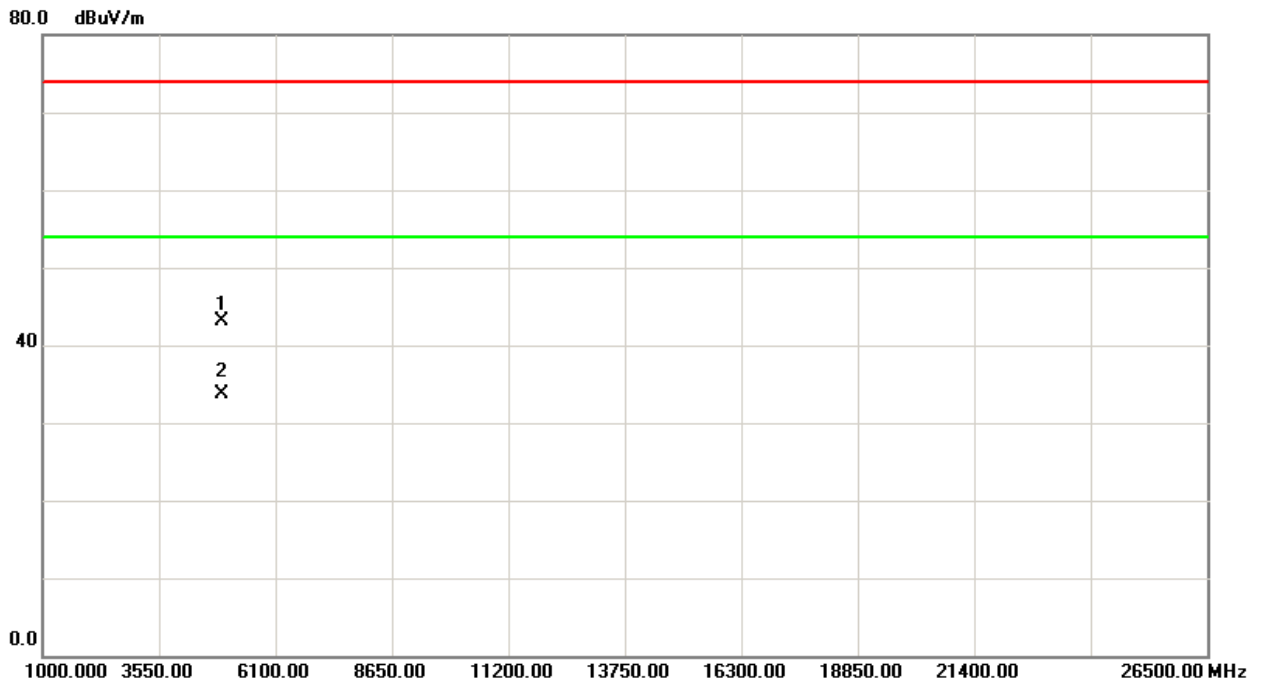
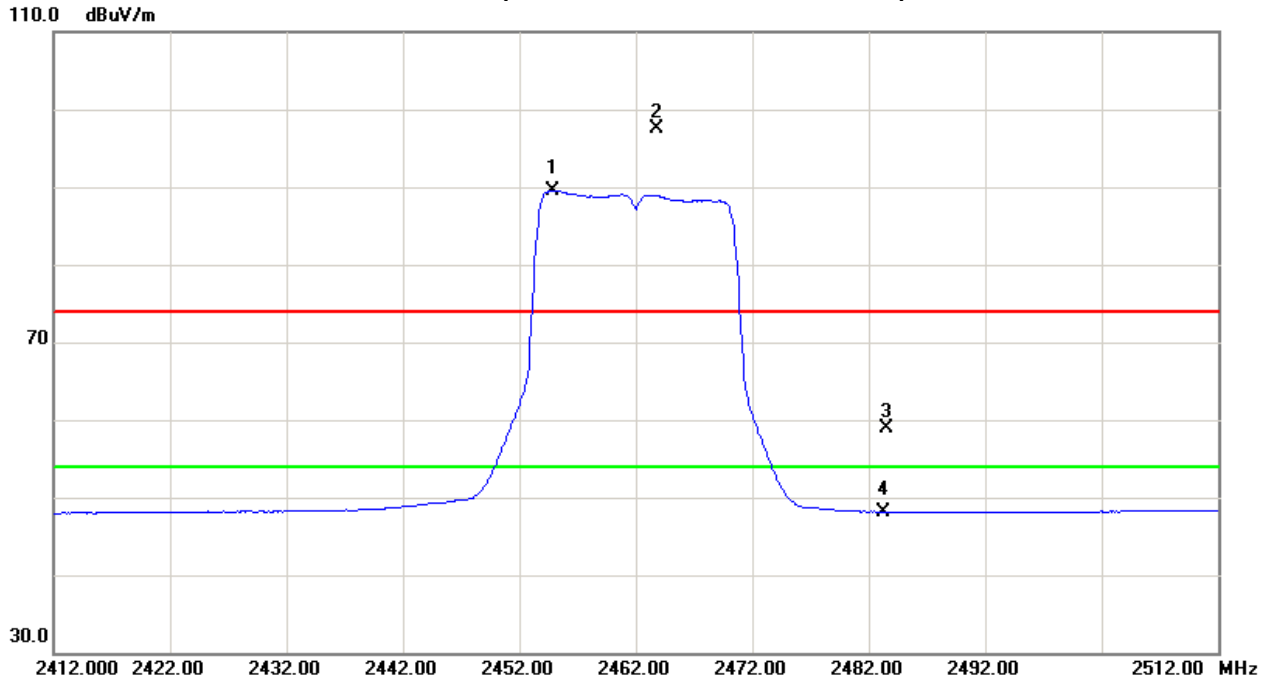



Test Mode : TX N-20M MODE 2412MHz

Freq. (MHz)	Ant.Pol. H/V	Reading (dBuV)		Ant./CF CF(dB)	Act. (dBuV/m)		Limit (dBuV/m)		Note
		Peak	AV		Peak	AV	Peak	AV	
2390.00	V	27.48	17.31	34.09	61.57	51.40	74.00	54.00	X/E
2419.90	V	75.45	65.29	34.18	109.63	99.47			X/F
4824.66	V	35.56	28.59	6.43	41.99	35.02	74.00	54.00	X/H

Freq. (MHz)	Ant.Pol. H/V	Reading (dBuV)		Ant./CF CF(dB)	Act. (dBuV/m)		Limit (dBuV/m)		Note
		Peak	AV		Peak	AV	Peak	AV	
2390.00	H	25.24	14.64	34.09	59.33	48.73	74.00	54.00	X/E
2419.00	H	67.35	56.74	34.18	101.53	90.92			X/F
4823.02	H	38.68	30.72	6.43	45.11	37.15	74.00	54.00	X/H



TX CH01 (Above 1000 MHz, Vertical)

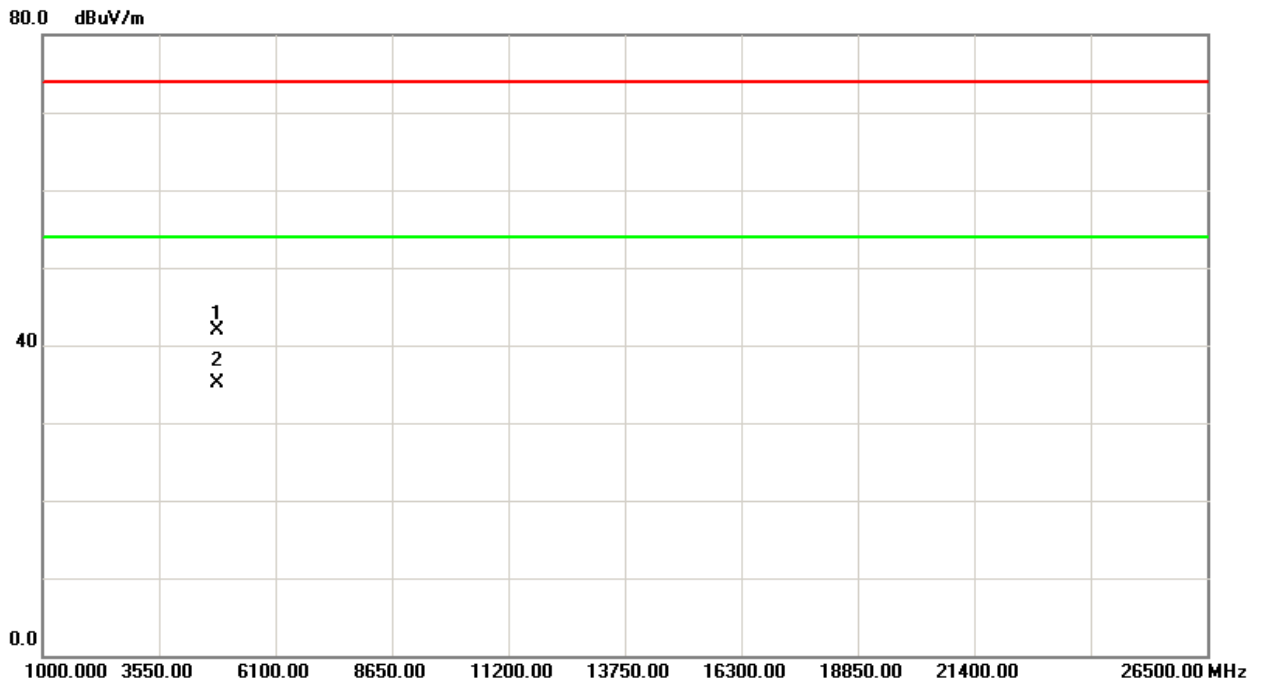
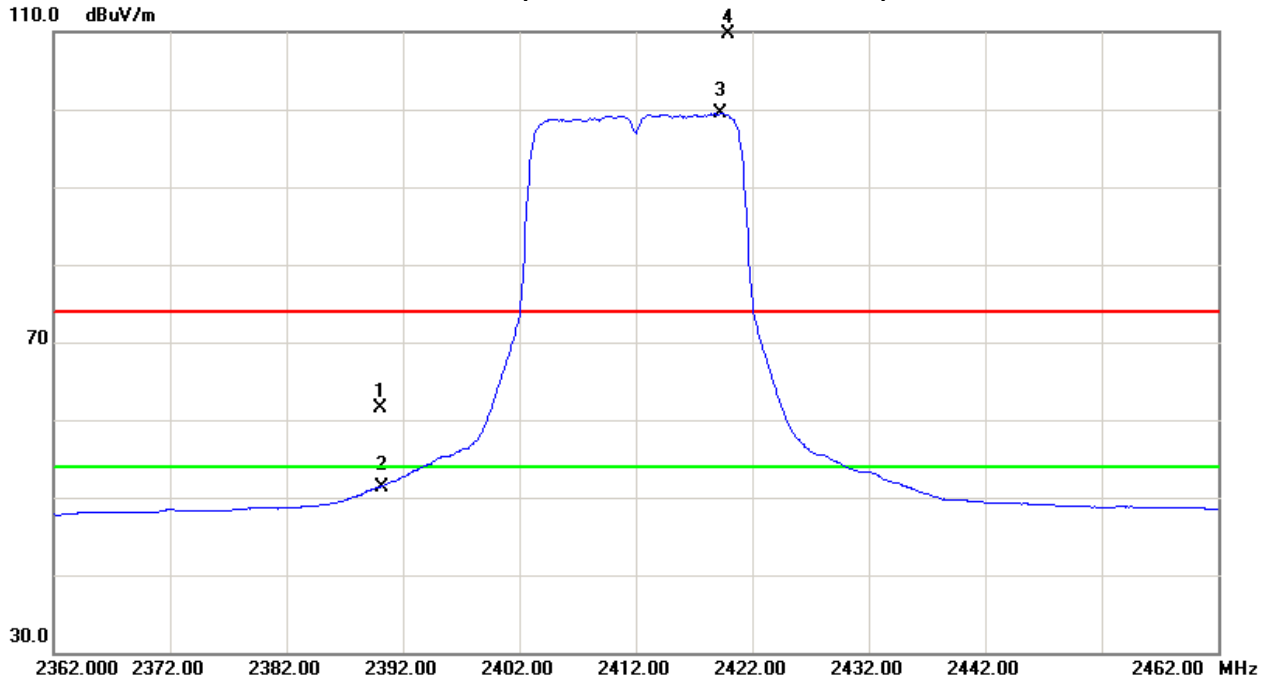



TX CH01 (Above 1000 MHz, Horizontal)

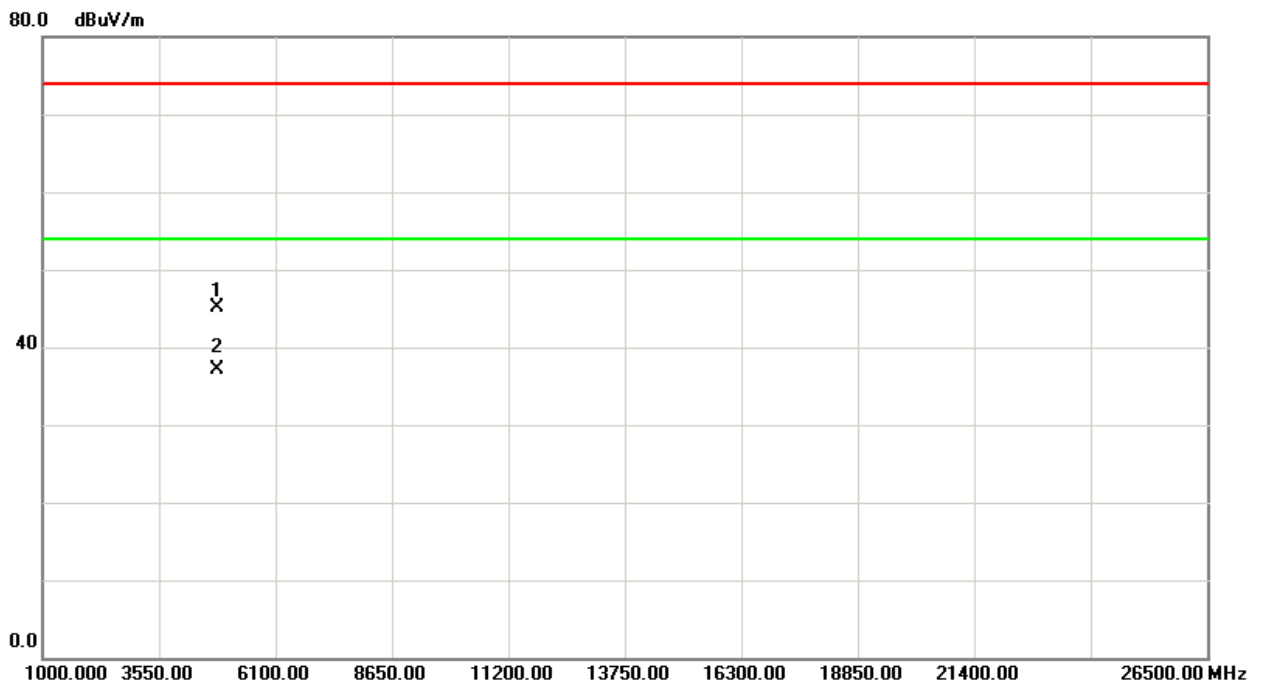
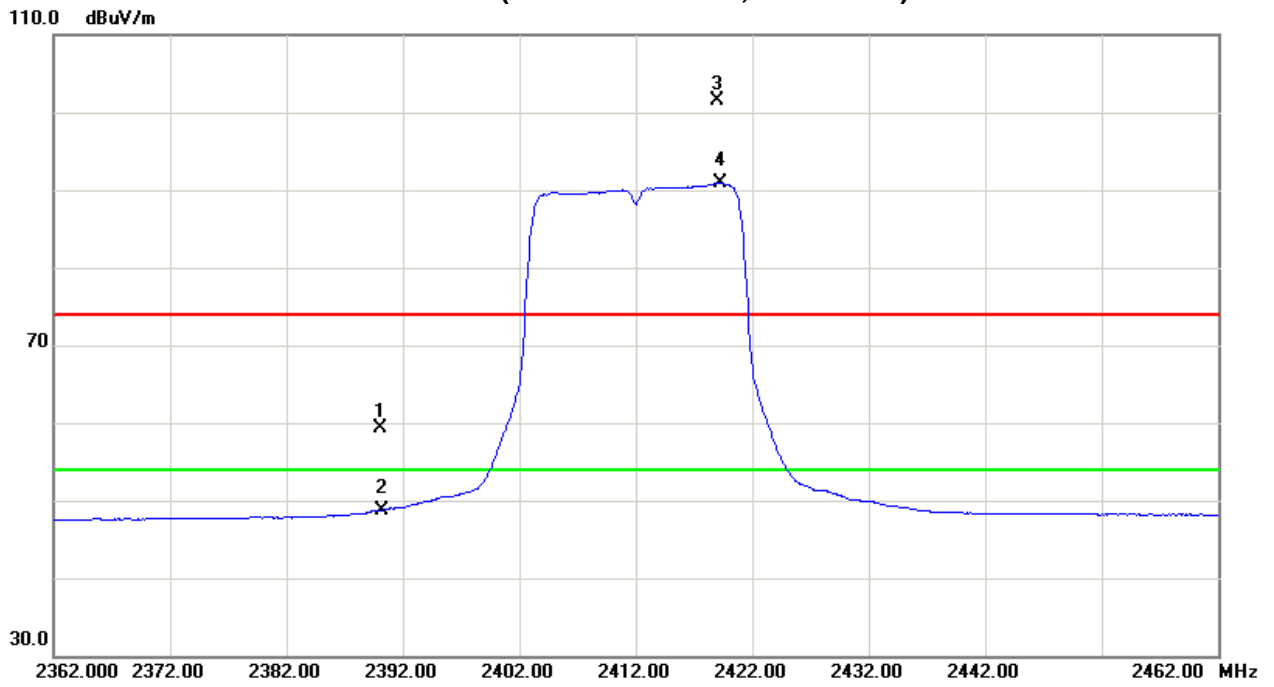



Test Mode : TX N-20M MODE 2437MHz

Freq. (MHz)	Ant.Pol. H/V	Reading		Ant./CF CF(dB)	Act.		Limit		Note
		Peak (dBuV)	AV (dBuV)		Peak (dBuV/m)	AV (dBuV/m)	Peak (dBuV/m)	AV (dBuV/m)	
2429.50	V	76.11	68.20	34.21	110.32	102.41			X/F
4874.52	V	36.40	27.45	6.58	42.98	34.03	74.00	54.00	X/H

Freq. (MHz)	Ant.Pol. H/V	Reading		Ant./CF CF(dB)	Act.		Limit		Note
		Peak (dBuV)	AV (dBuV)		Peak (dBuV/m)	AV (dBuV/m)	Peak (dBuV/m)	AV (dBuV/m)	
2430.60	H	71.91	62.88	34.21	106.12	97.09			X/F
4874.52	H	39.55	31.63	6.58	46.13	38.21	74.00	54.00	X/H

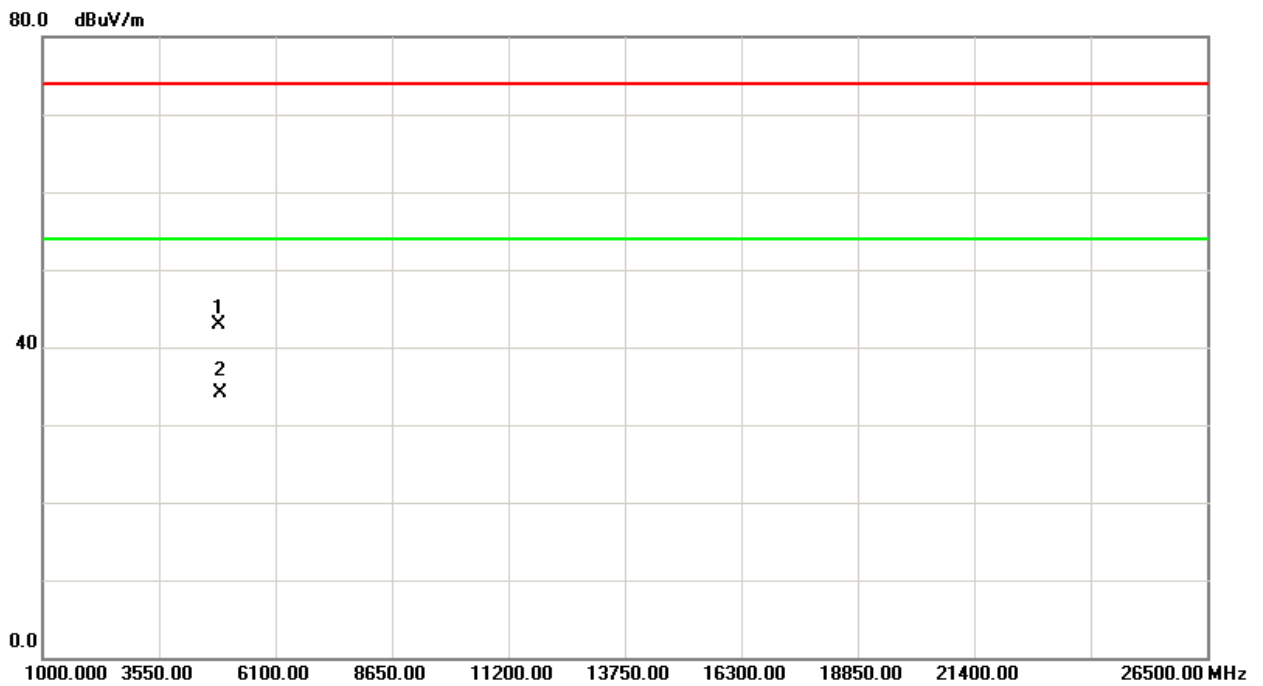
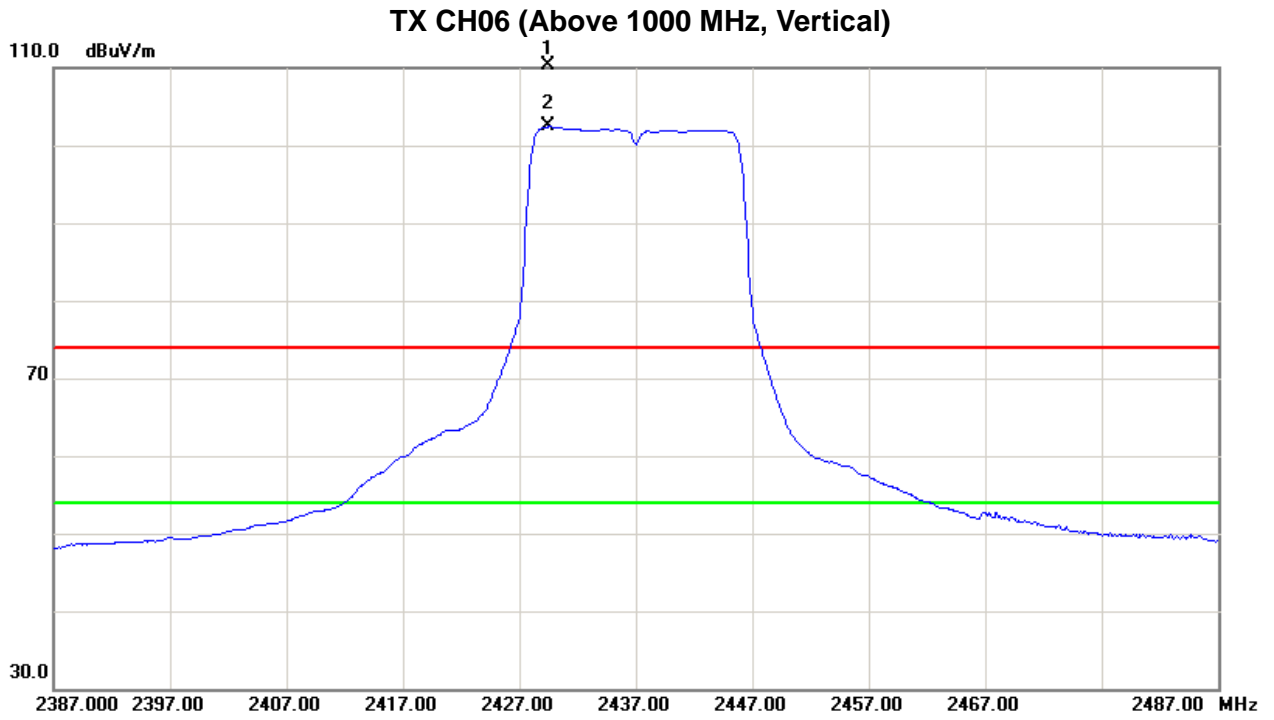



TX CH06 (Above 1000 MHz, Horizontal)

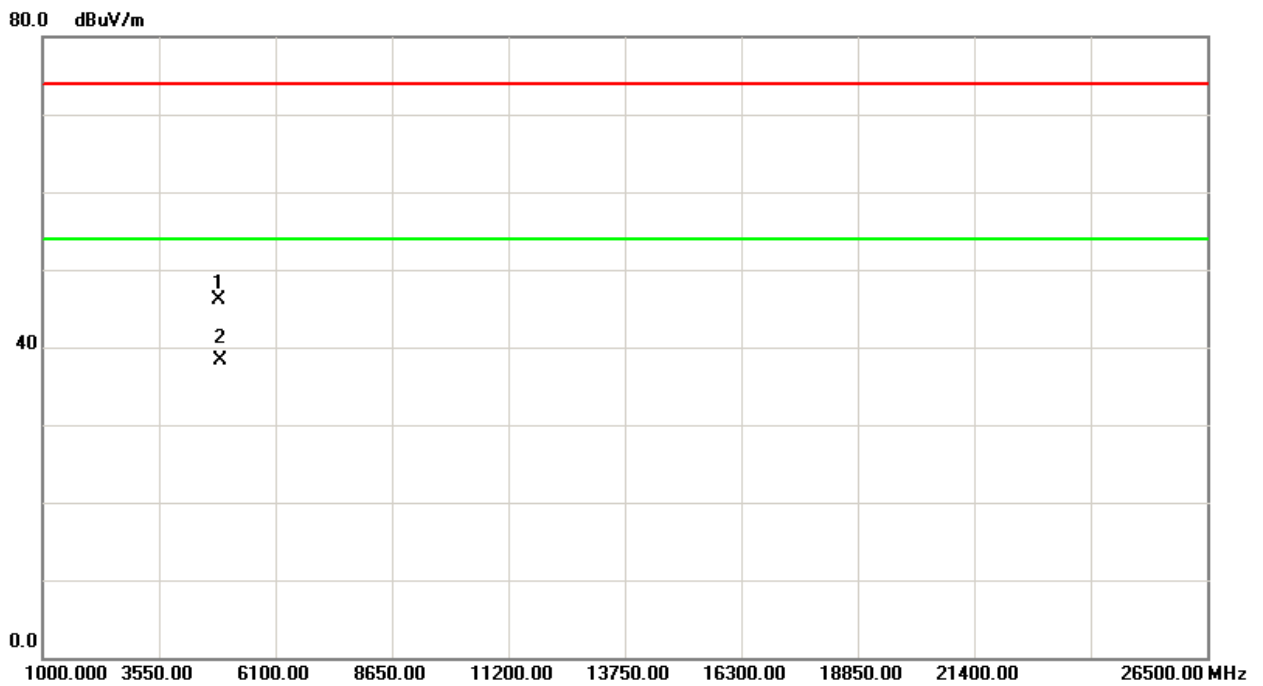
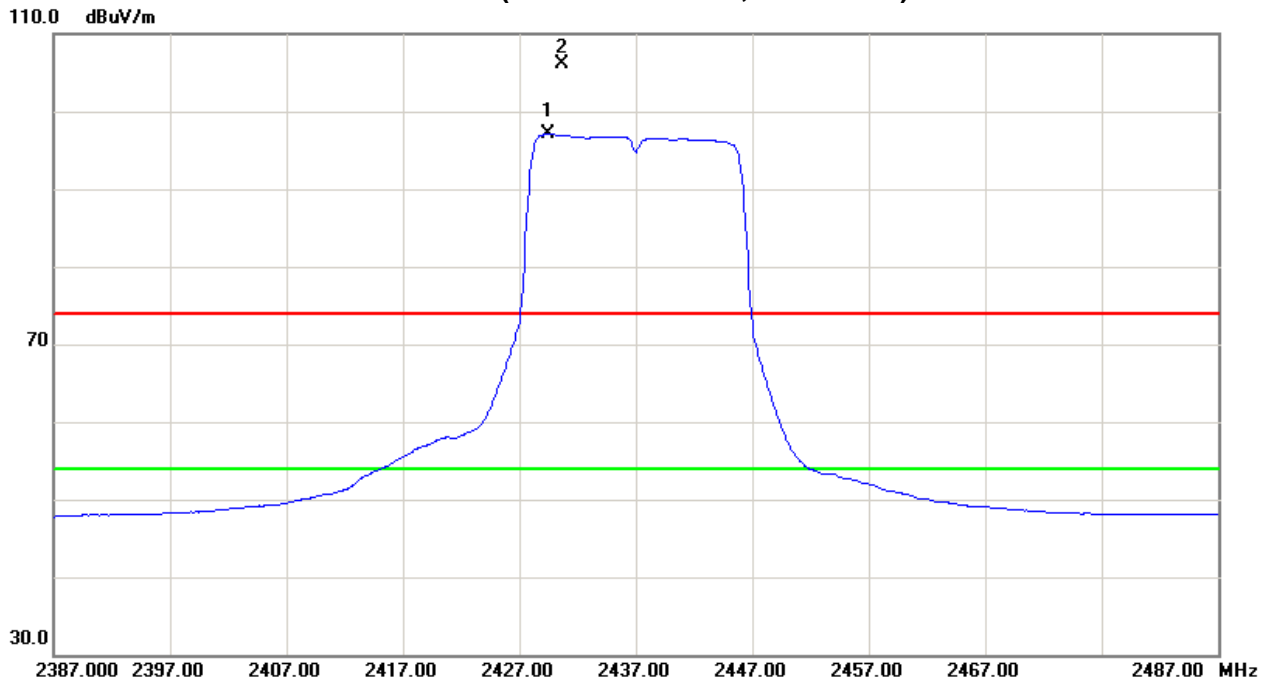



Neutron Engineering Inc.

Test Mode : TX N-20M MODE 2462MHz

Freq. (MHz)	Ant.Pol. H/V	Reading		Ant./CF CF(dB)	Act.		Limit		Note
		Peak (dBuV)	AV (dBuV)		Peak (dBuV/m)	AV (dBuV/m)	Peak (dBuV/m)	AV (dBuV/m)	
2460.90	V	66.31	65.31	34.31	100.62	99.62			X/F
2483.50	V	28.40	17.25	34.37	62.77	51.62	74.00	54.00	X/E
4923.96	V	34.57	26.12	6.72	41.29	32.84	74.00	54.00	X/H

Freq. (MHz)	Ant.Pol. H/V	Reading		Ant./CF CF(dB)	Act.		Limit		Note
		Peak (dBuV)	AV (dBuV)		Peak (dBuV/m)	AV (dBuV/m)	Peak (dBuV/m)	AV (dBuV/m)	
2455.30	H	65.58	57.20	34.29	99.87	91.49			X/F
2483.50	H	25.52	14.36	34.37	59.89	48.73	74.00	54.00	X/E
4924.02	H	35.37	27.46	6.72	42.09	34.18	74.00	54.00	X/H



TX CH11 (Above 1000 MHz, Vertical)

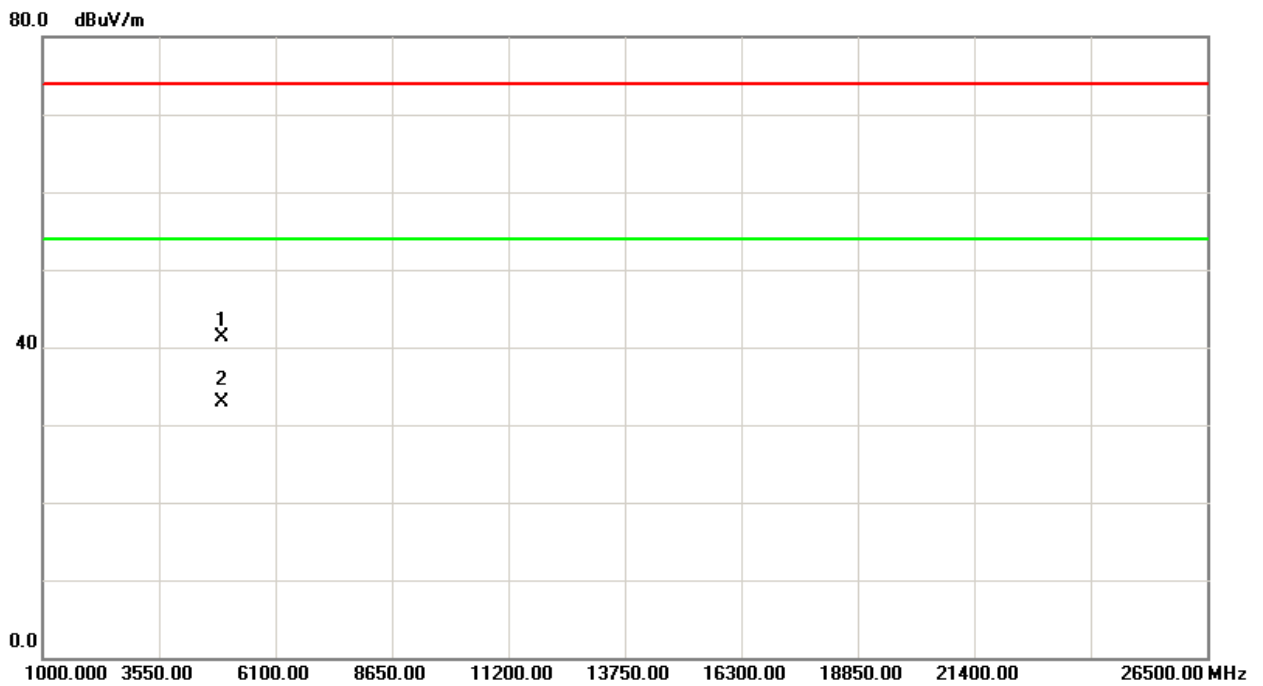
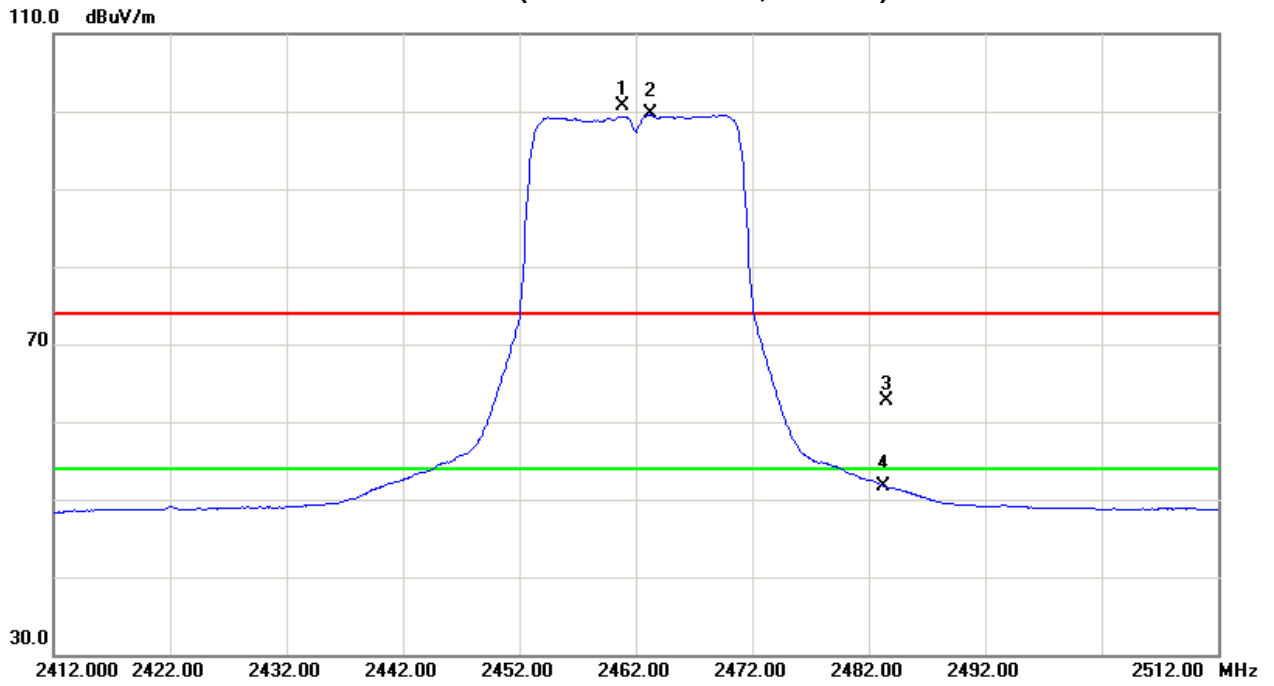



TX CH11 (Above 1000 MHz, Horizontal)

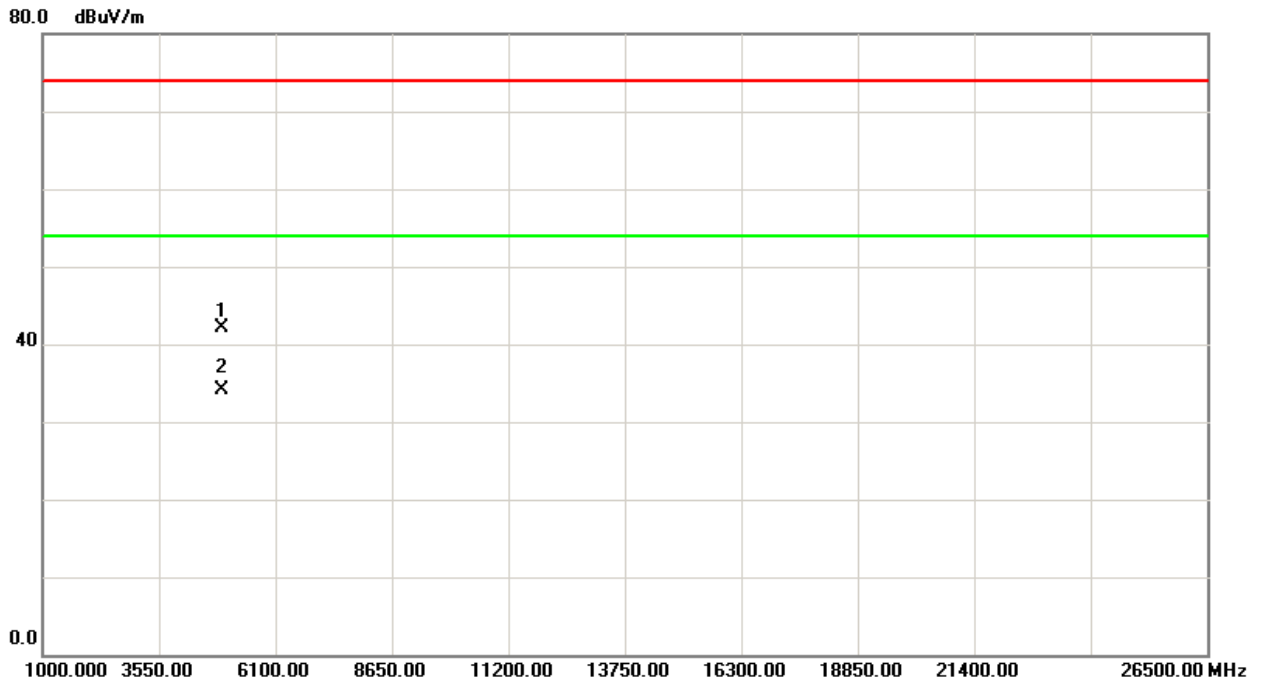
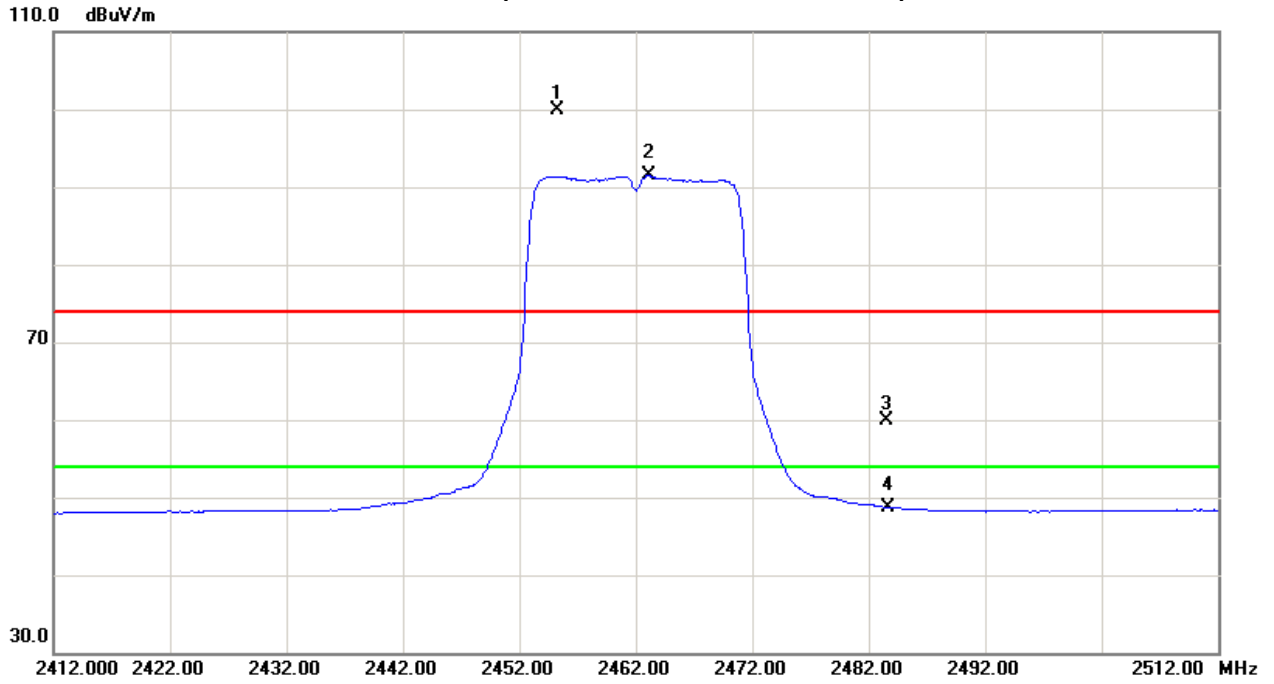



Neutron Engineering Inc.

Test Mode : TX N-40M MODE 2422MHz

Freq. (MHz)	Ant.Pol. H/V	Reading		Ant./CF CF(dB)	Act.		Limit		Note
		Peak (dBuV)	AV (dBuV)		Peak (dBuV/m)	AV (dBuV/m)	Peak (dBuV/m)	AV (dBuV/m)	
2390.00	V	25.79	16.35	34.09	59.88	50.44	74.00	54.00	X/E
2412.60	V	70.10	57.88	34.16	104.26	92.04			X/F
4843.98	V	36.20	27.32	6.50	42.70	33.82	74.00	54.00	X/H

Freq. (MHz)	Ant.Pol. H/V	Reading		Ant./CF CF(dB)	Act.		Limit		Note
		Peak (dBuV)	AV (dBuV)		Peak (dBuV/m)	AV (dBuV/m)	Peak (dBuV/m)	AV (dBuV/m)	
2390.00	H	25.40	16.00	34.09	59.49	50.09	74.00	54.00	X/E
2427.00	H	64.18	53.45	34.20	98.38	87.65			X/F
4844.08	H	35.65	27.74	6.50	42.15	34.24	74.00	54.00	X/H



TX CH03 (Above 1000 MHz, Vertical)

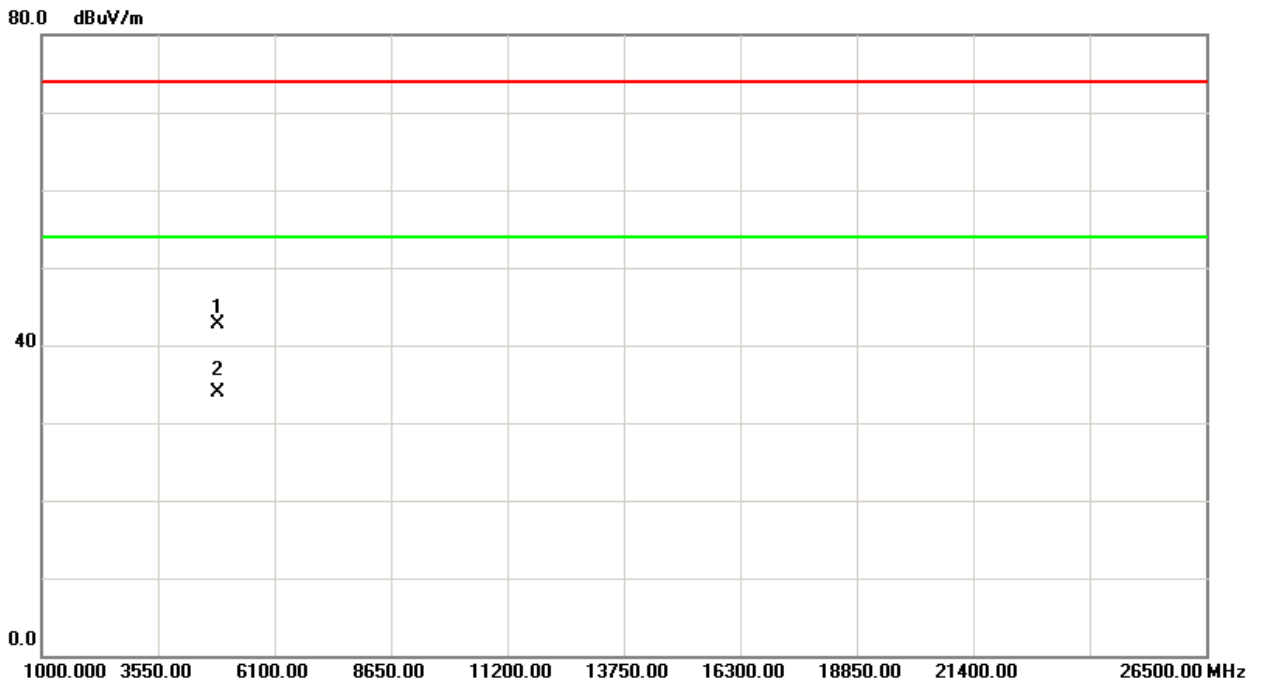
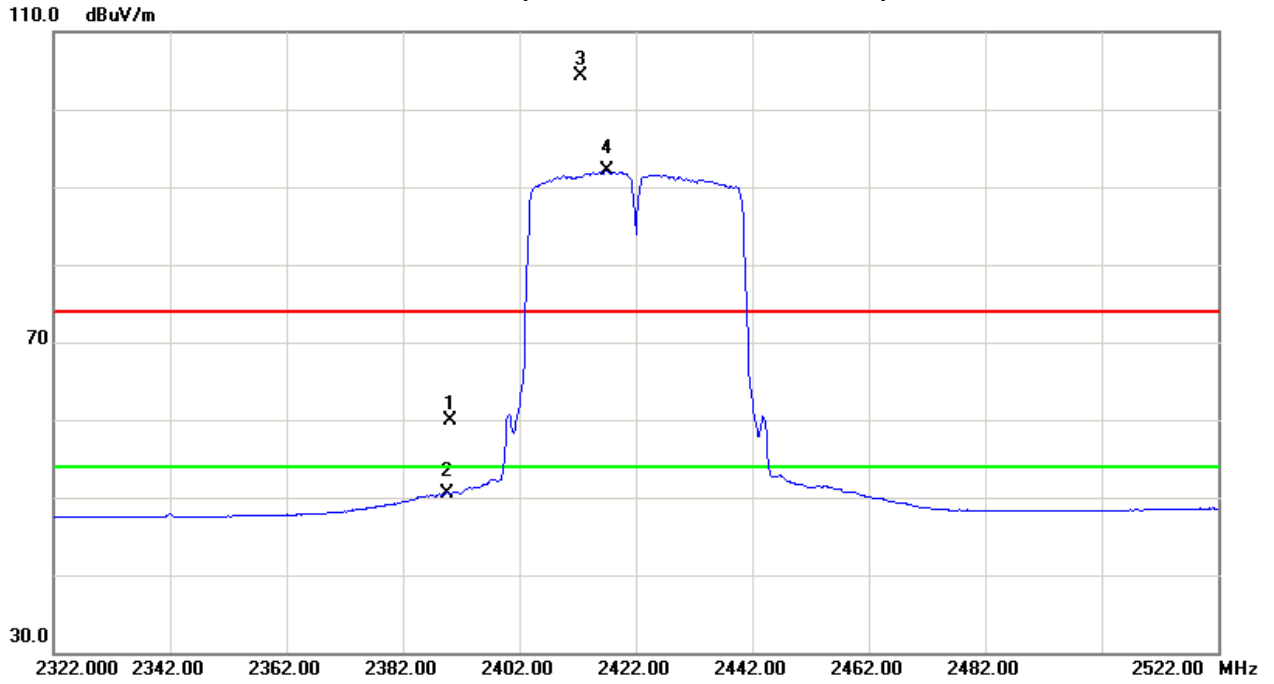



TX CH03 (Above 1000 MHz, Horizontal)

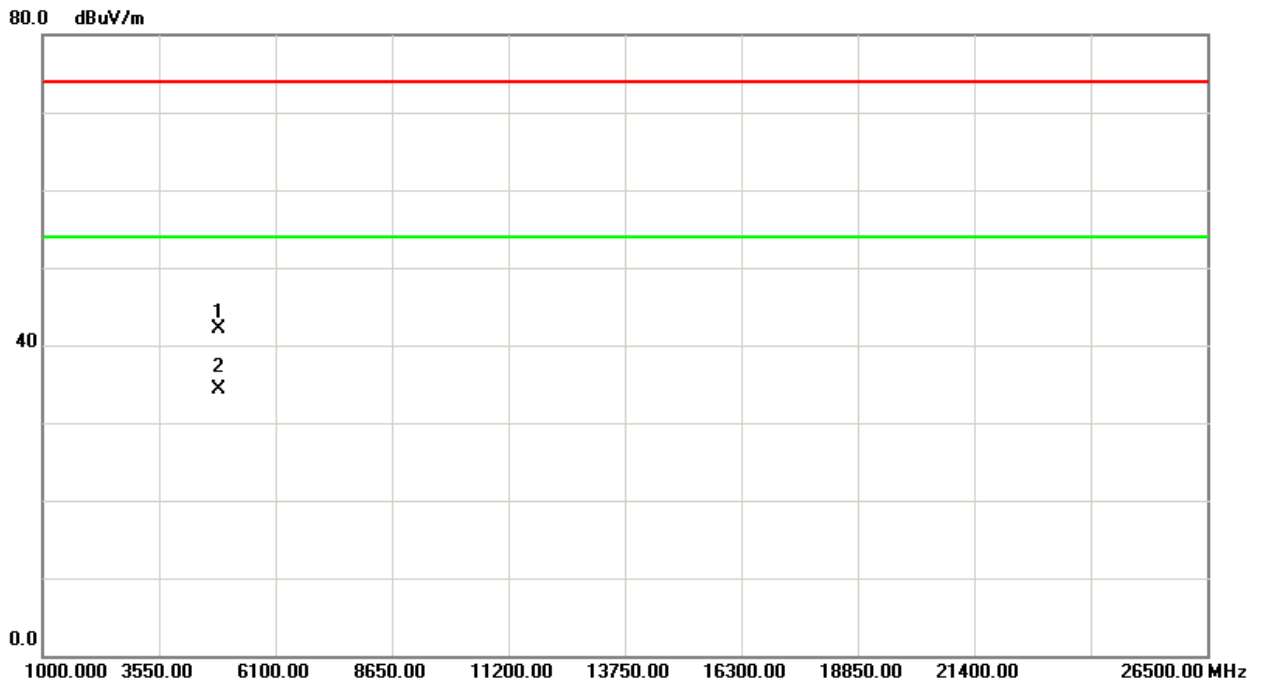
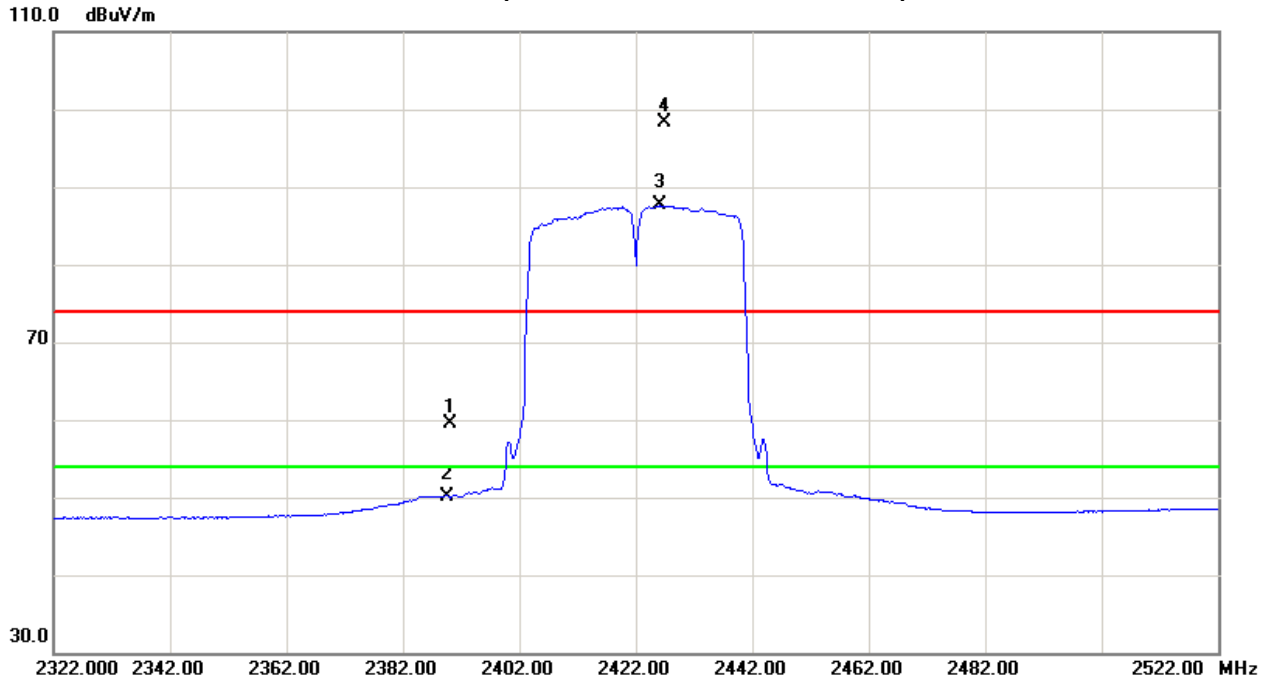



Test Mode : TX N-40M MODE 2437MHz

Freq. (MHz)	Ant.Pol. H/V	Reading		Ant./CF CF(dB)	Act.		Limit		Note
		Peak (dBuV)	AV (dBuV)		Peak (dBuV/m)	AV (dBuV/m)	Peak (dBuV/m)	AV (dBuV/m)	
2442.00	V	71.17	63.81	34.19	105.36	98.00			X/F
4874.02	V	34.36	26.87	6.58	40.94	33.45	74.00	54.00	X/H

Freq. (MHz)	Ant.Pol. H/V	Reading		Ant./CF CF(dB)	Act.		Limit		Note
		Peak (dBuV)	AV (dBuV)		Peak (dBuV/m)	AV (dBuV/m)	Peak (dBuV/m)	AV (dBuV/m)	
2422.00	H	65.88	58.60	34.19	100.07	92.79			X/F
4874.02	H	35.21	27.12	6.58	41.79	33.70	74.00	54.00	X/H



TX CH06 (Above 1000 MHz, Vertical)

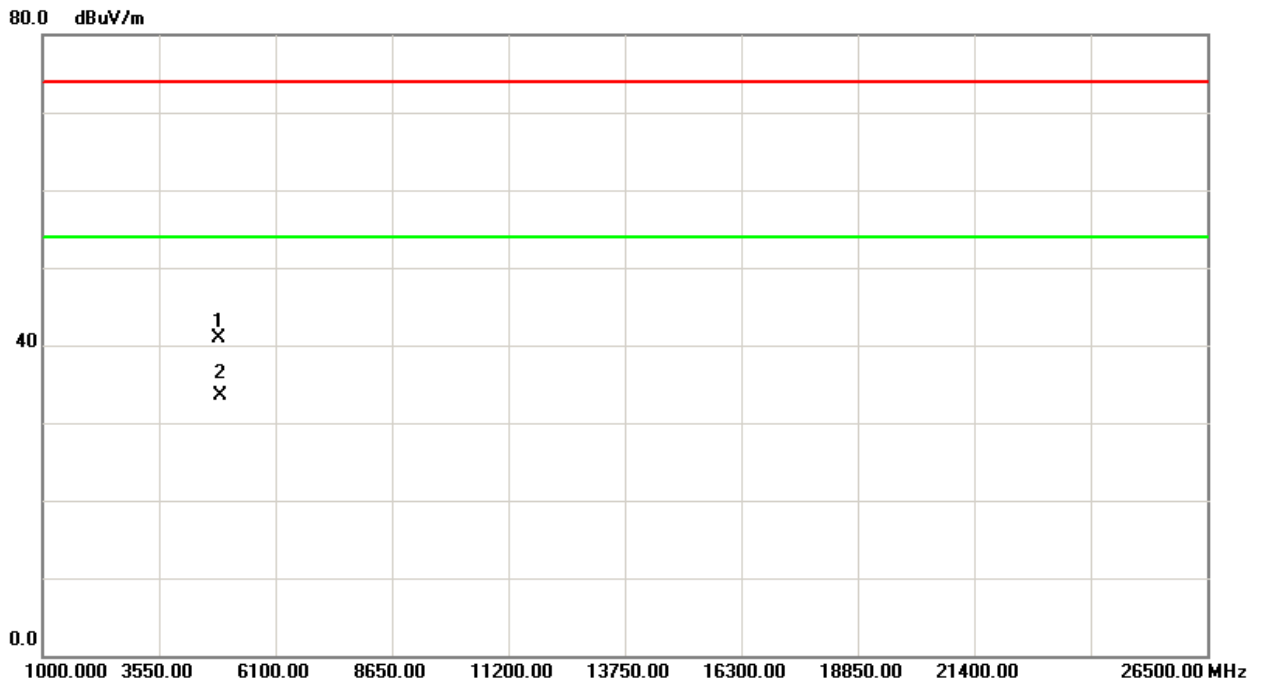
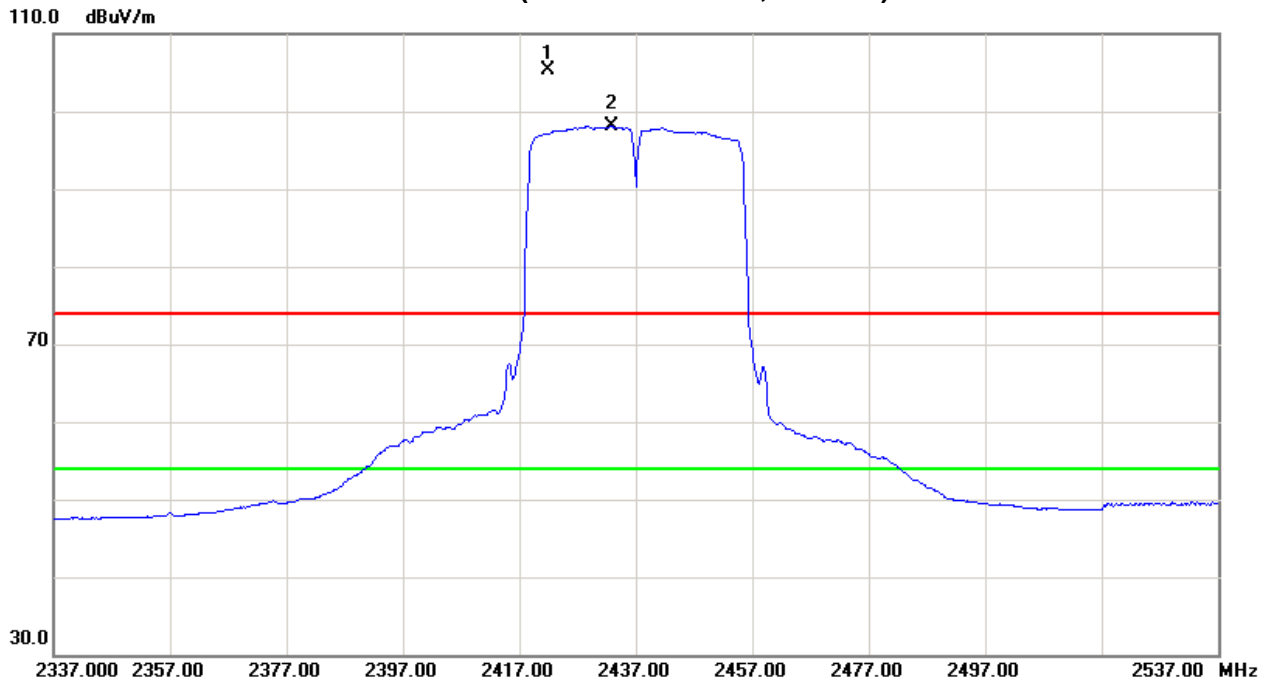



TX CH06 (Above 1000 MHz, Horizontal)

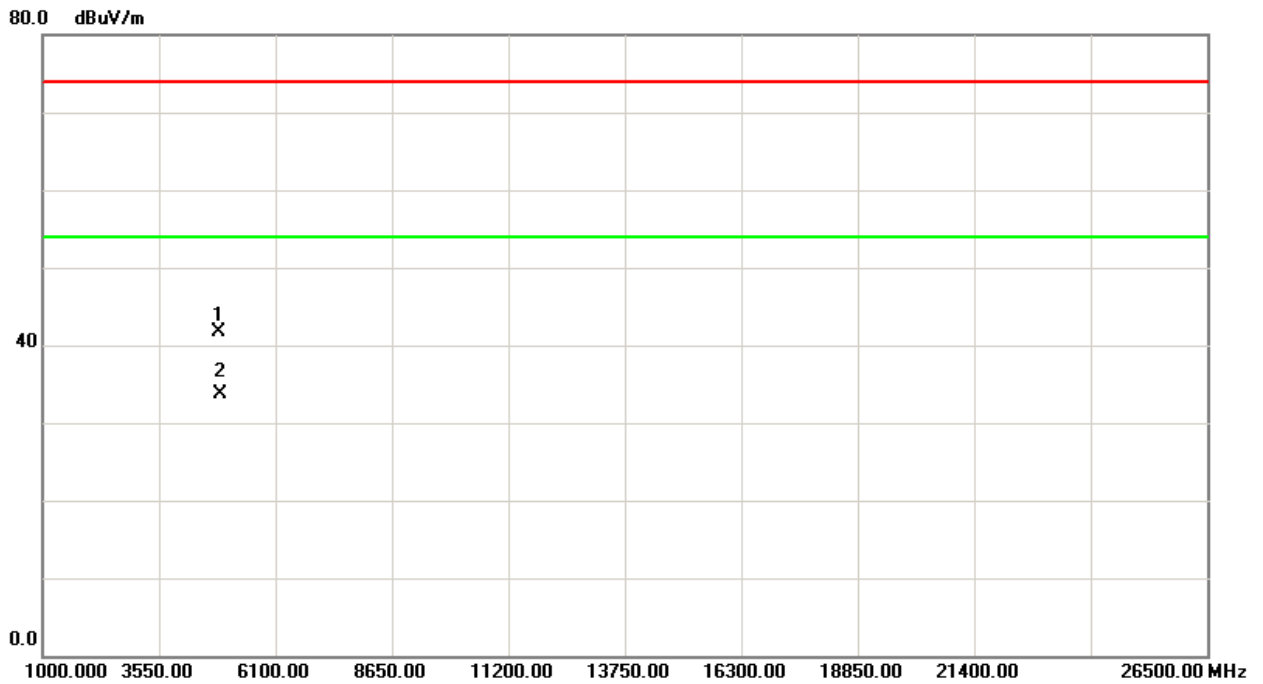
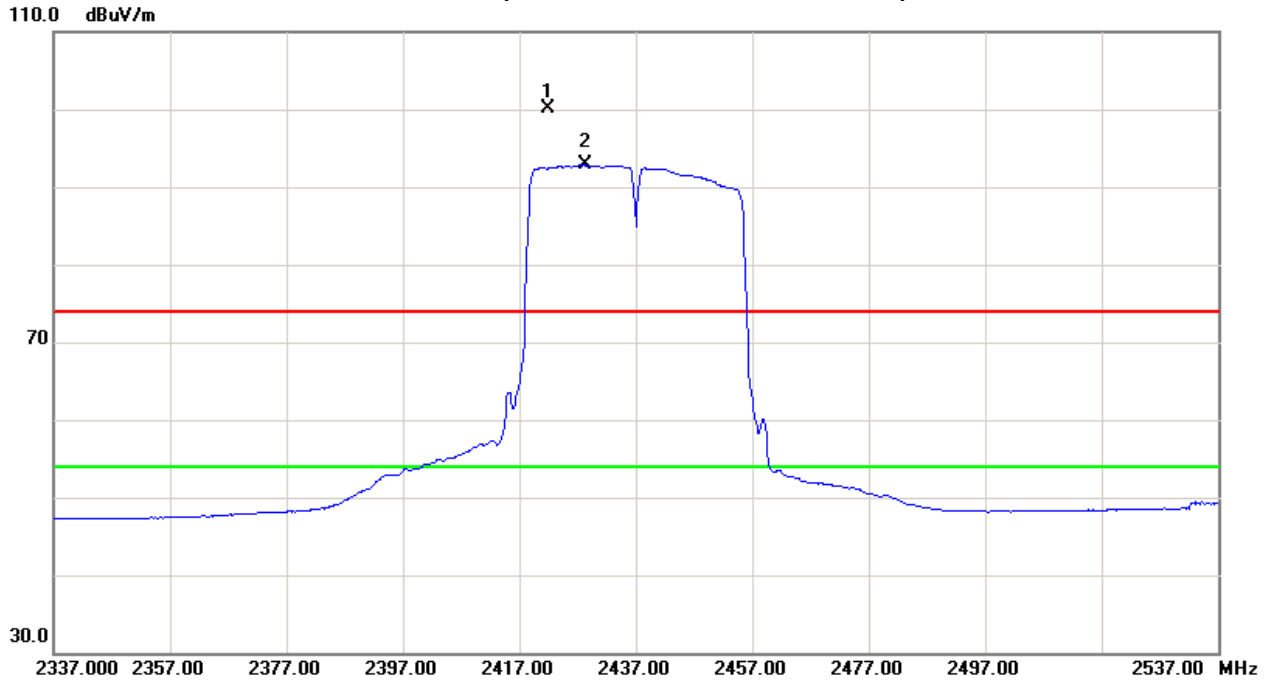



Neutron Engineering Inc.

Test Mode : TX N-40M MODE 2452MHz

Freq. (MHz)	Ant.Pol. H/V	Reading		Ant./CF CF(dB)	Act.		Limit		Note
		Peak (dBuV)	AV (dBuV)		Peak (dBuV/m)	AV (dBuV/m)	Peak (dBuV/m)	AV (dBuV/m)	
2442.60	V	68.08	57.48	34.25	102.33	91.73			X/F
2483.50	V	25.53	35.19	34.37	59.90	69.56	74.00	54.00	X/E
4904.00	V	36.41	26.80	6.67	43.08	33.47	74.00	54.00	X/H

Freq. (MHz)	Ant.Pol. H/V	Reading		Ant./CF CF(dB)	Act.		Limit		Note
		Peak (dBuV)	AV (dBuV)		Peak (dBuV/m)	AV (dBuV/m)	Peak (dBuV/m)	AV (dBuV/m)	
2455.60	H	60.82	49.37	34.29	95.11	83.66			X/F
2483.50	H	24.04	14.18	34.37	58.41	48.55	74.00	54.00	X/E
4904.00	H	33.87	28.22	6.67	40.54	34.89	74.00	54.00	X/H



TX CH09 (Above 1000 MHz, Vertical)

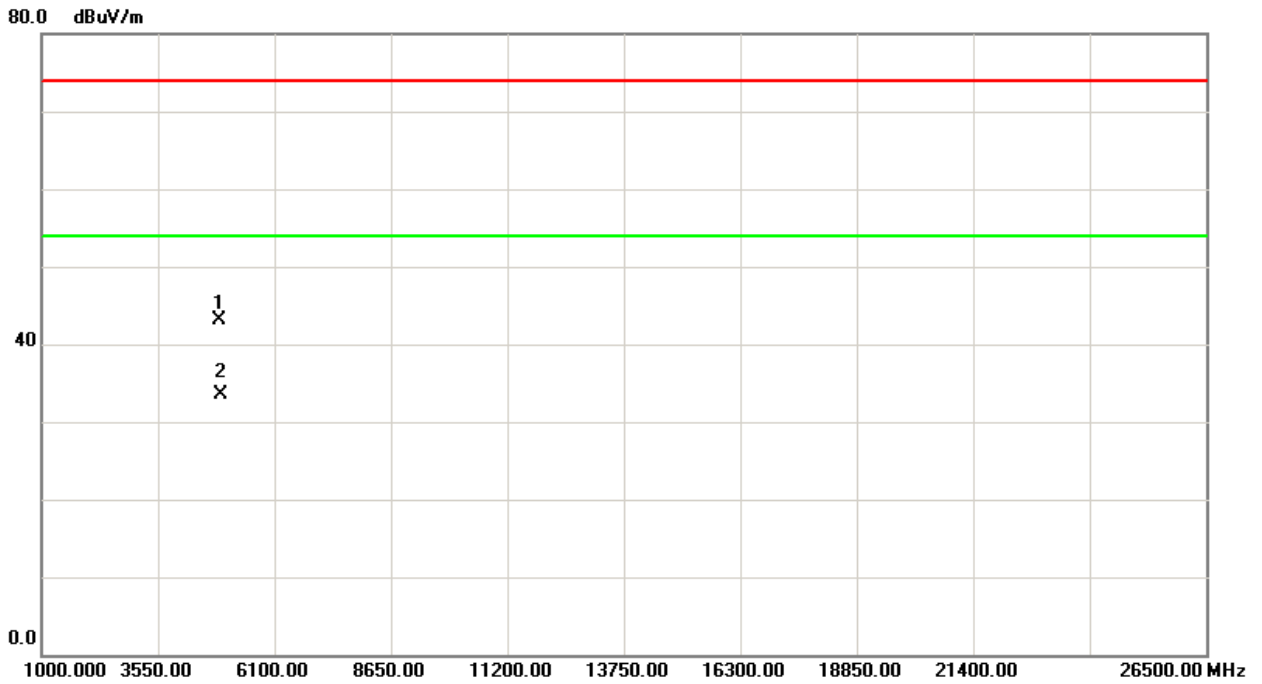
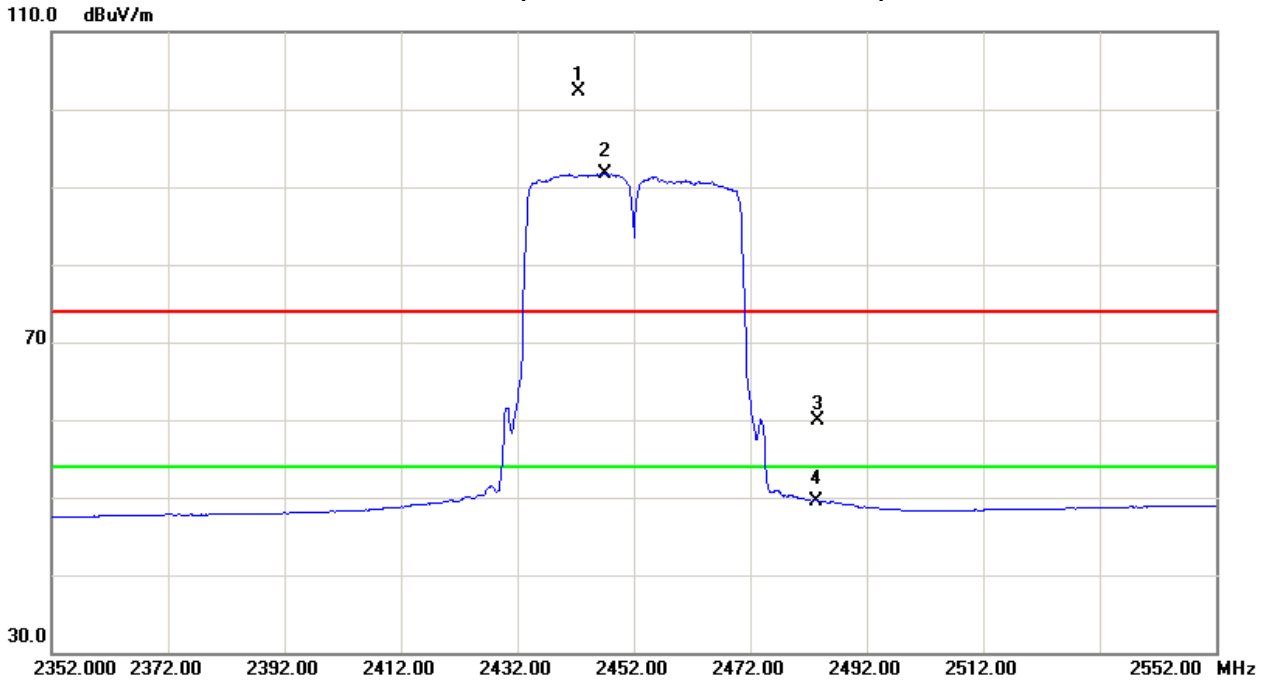



TX CH09 (Above 1000 MHz, Horizontal)

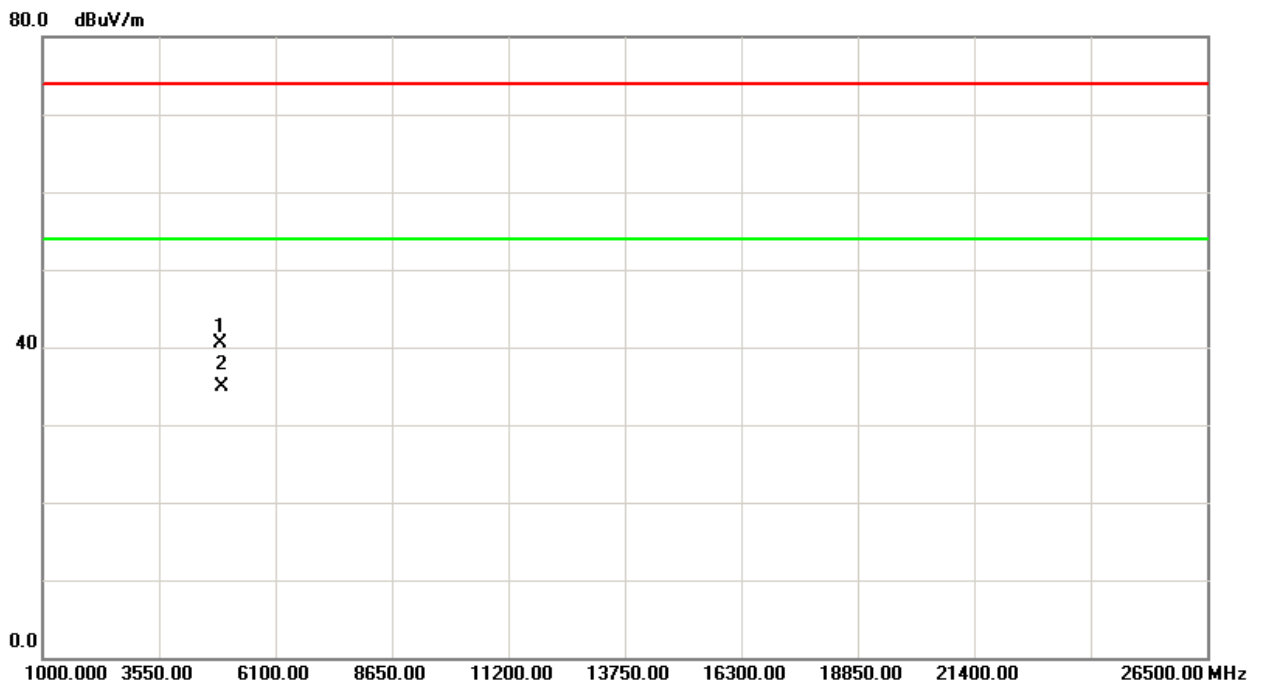
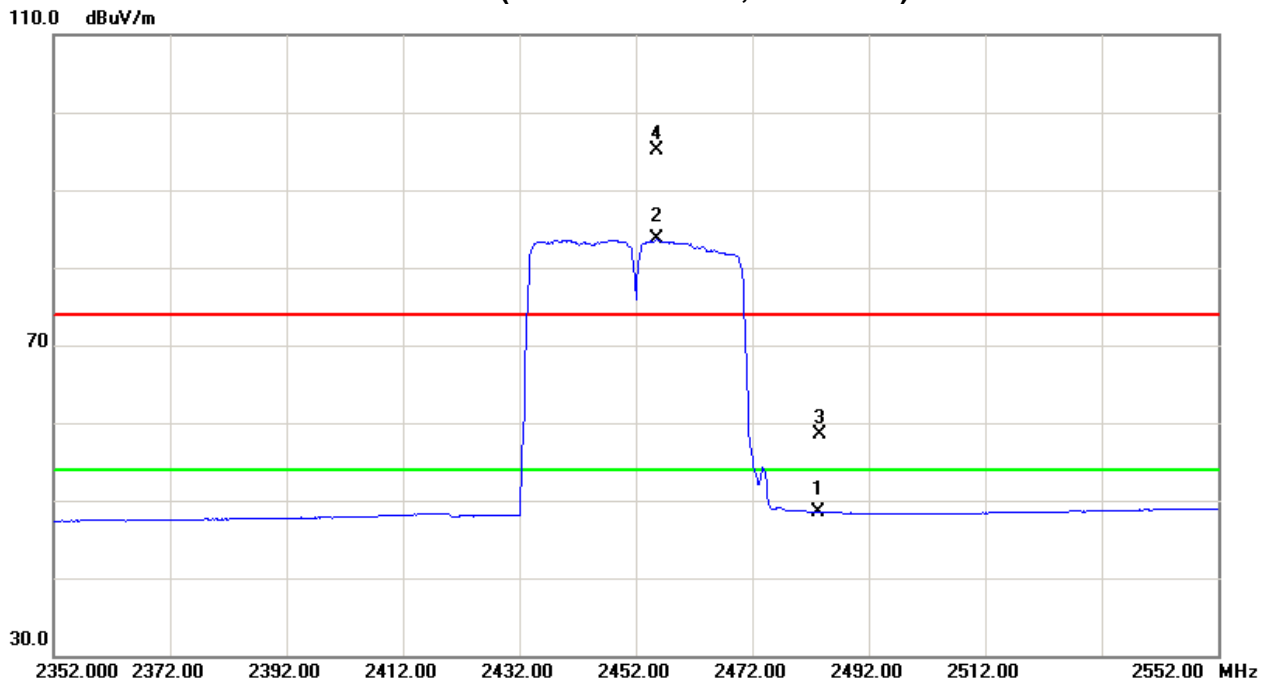



5. BANDWIDTH TEST

5.1 Applied procedures

FCC Part15 (15.247) , Subpart C			
Section	Test Item	Frequency Range (MHz)	Result
15.247(a)(2)	Bandwidth	2400-2483.5	PASS

5.1.1 TEST PROCEDURE

- a. The EUT was directly connected to the spectrum analyzer and antenna output port as show in the block diagram below,
- b. Spectrum Setting : RBW= 100KHz, VBW=300KHz, Sweep time = 2.5 ms.

5.1.2 DEVIATION FROM STANDARD

No deviation.

5.1.3 TEST SETUP

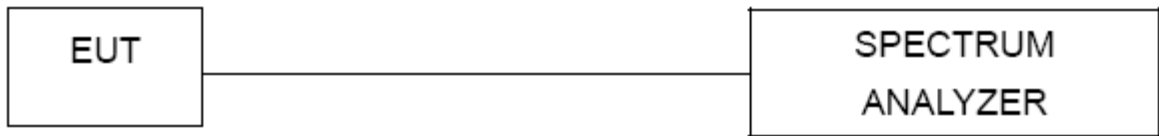

5.1.4 EUT OPERATION CONDITIONS

The EUT tested system was configured as the statements of 4.1.6 Unless otherwise a special operating condition is specified in the follows during the testing.

5.1.5 EUT TEST CONDITIONS

Temperature: 25°C
 Relative Humidity: 55%
 Test Voltage: 120V/60Hz



5.1.6 TEST RESULTS

Test Mode : TX B Mode

Test Channel	Frequency (MHz)	Bandwidth (MHz)	99% Occupied Bandwidth (MHz)	Result
CH01	2412	10.12	15.05	PASS
CH06	2437	10.12	15.05	PASS
CH11	2462	10.12	15.00	PASS

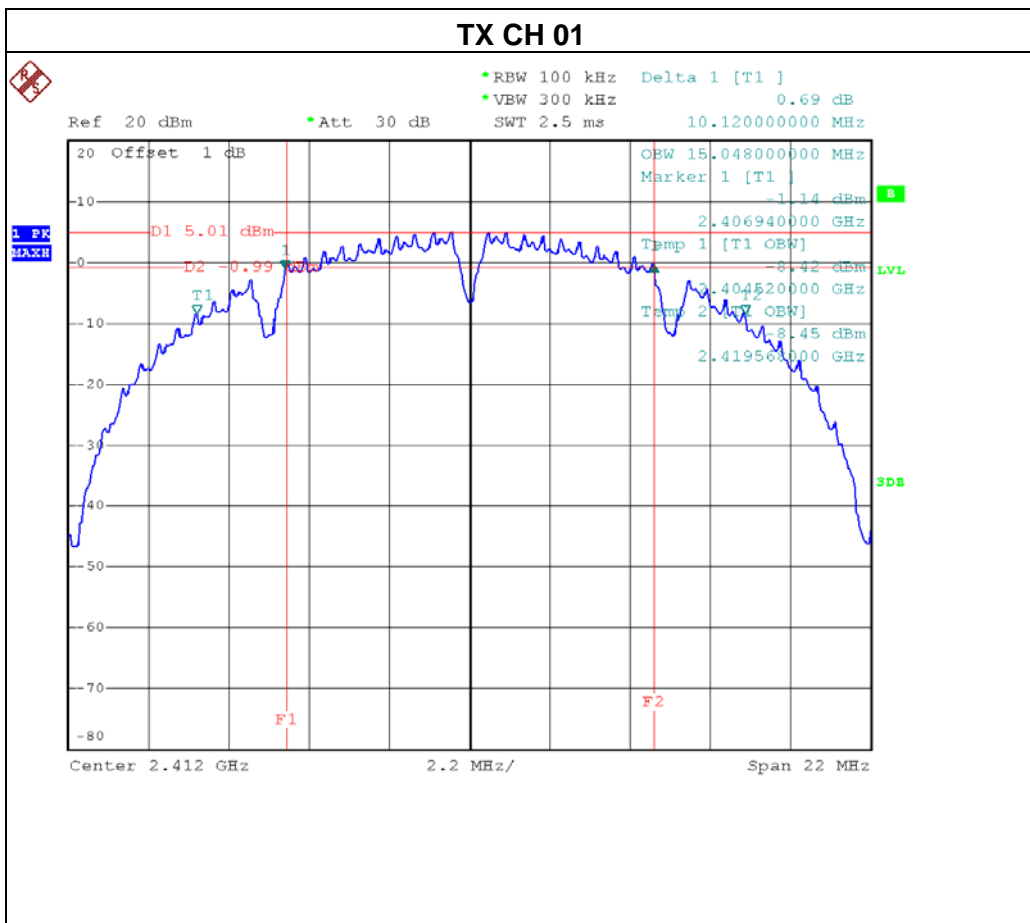

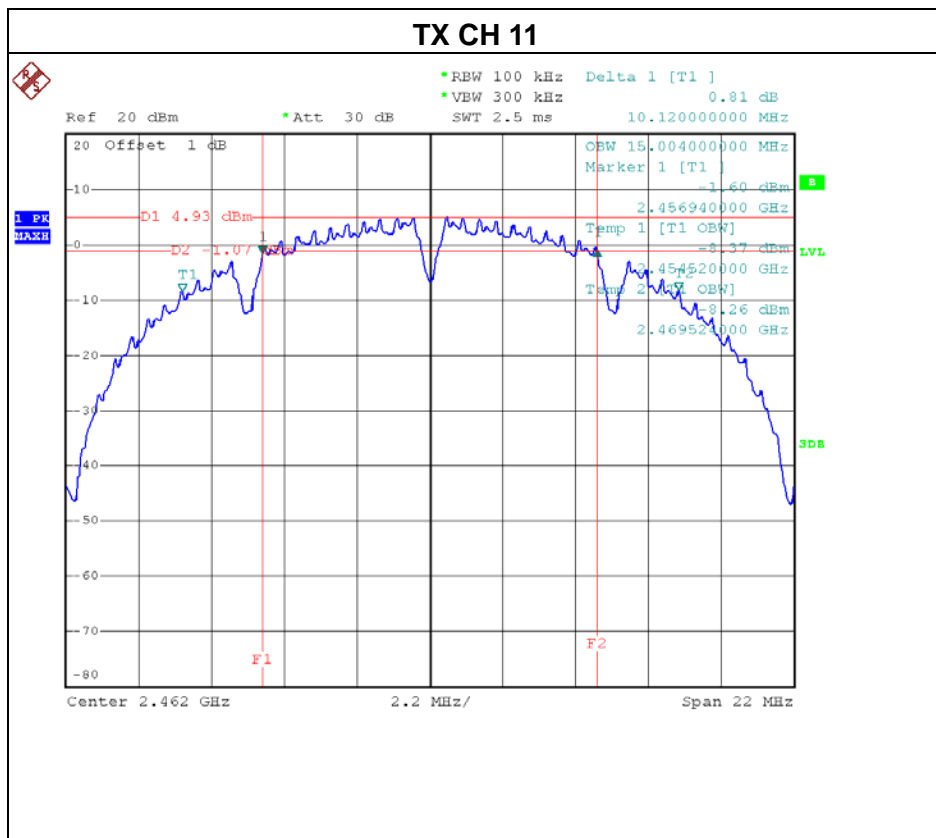
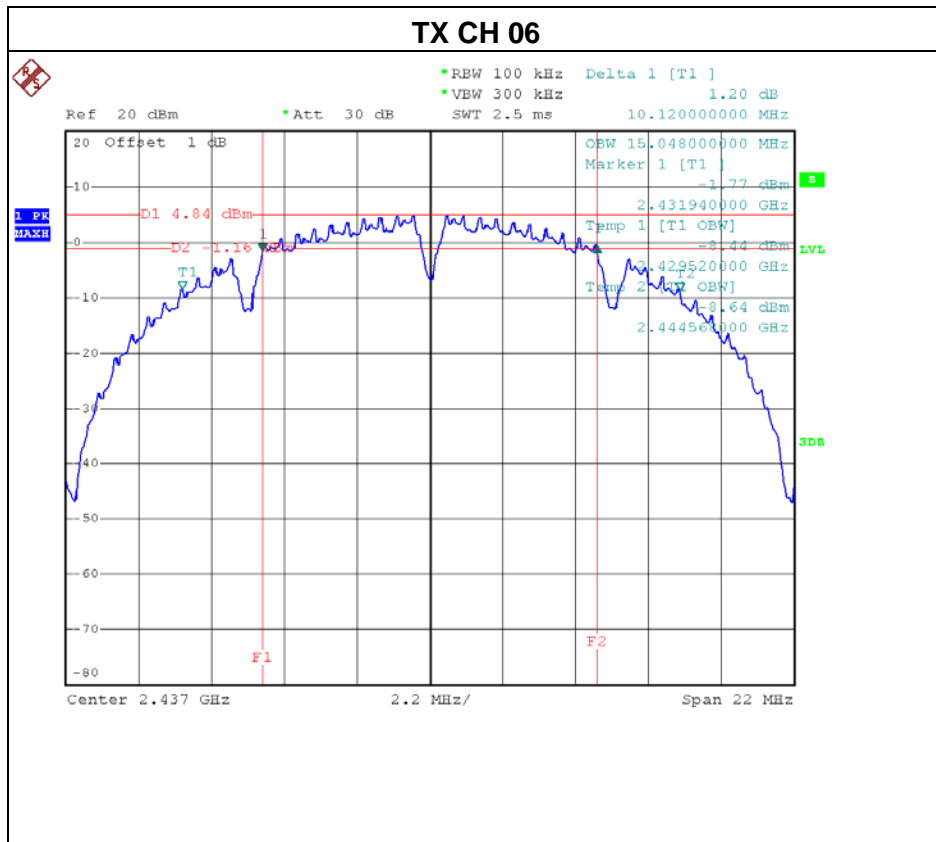



Test Mode: TX G Mode				
Test Channel	Frequency (MHz)	Bandwidth (MHz)	99% Occupied Bandwidth (MHz)	Result
CH01	2412	16.63	16.54	PASS
CH06	2437	16.63	16.54	PASS
CH11	2462	16.59	16.54	PASS

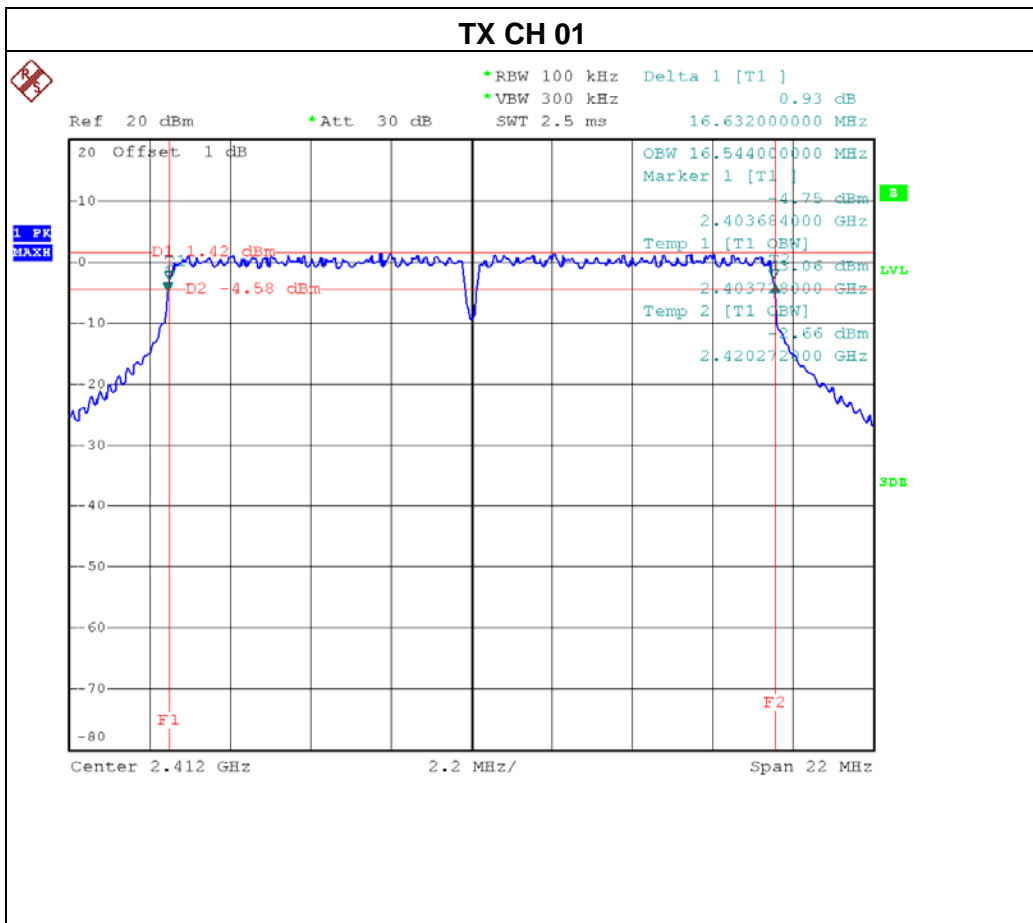

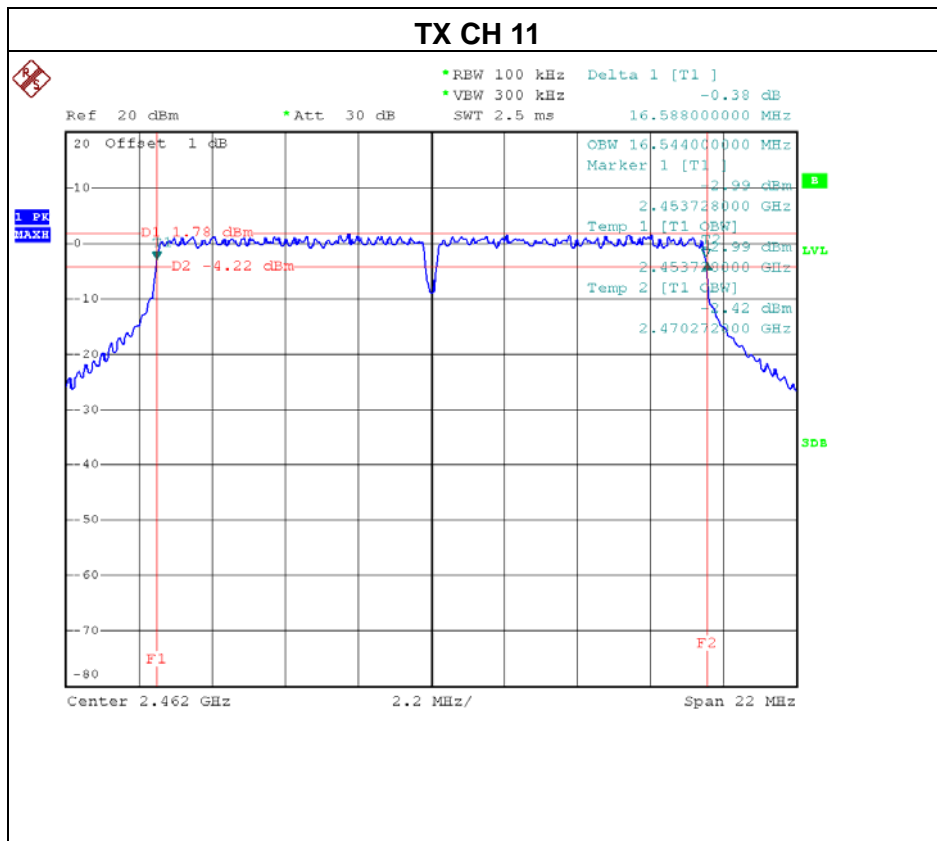
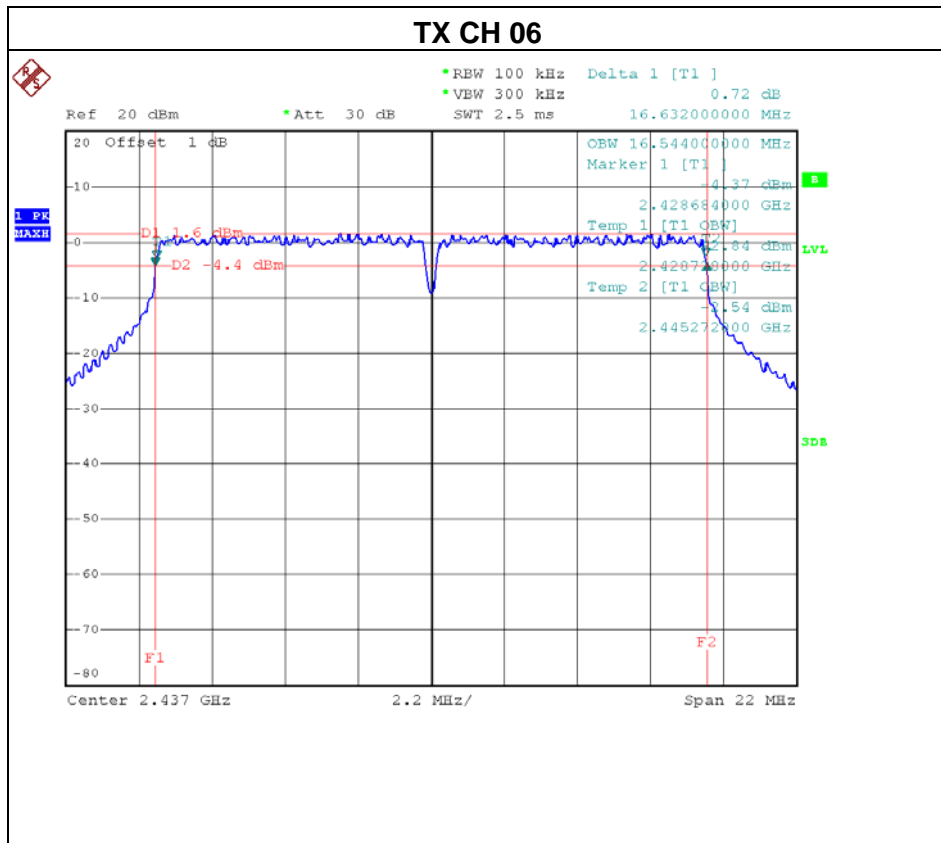



Test Mode : TX N-20MHz Mode-ANT 1				
Test Channel	Frequency (MHz)	Bandwidth (MHz)	99% Occupied Bandwidth (MHz)	Result
CH01	2412	17.91	17.73	PASS
CH06	2437	17.91	17.73	PASS
CH11	2462	17.91	17.73	PASS

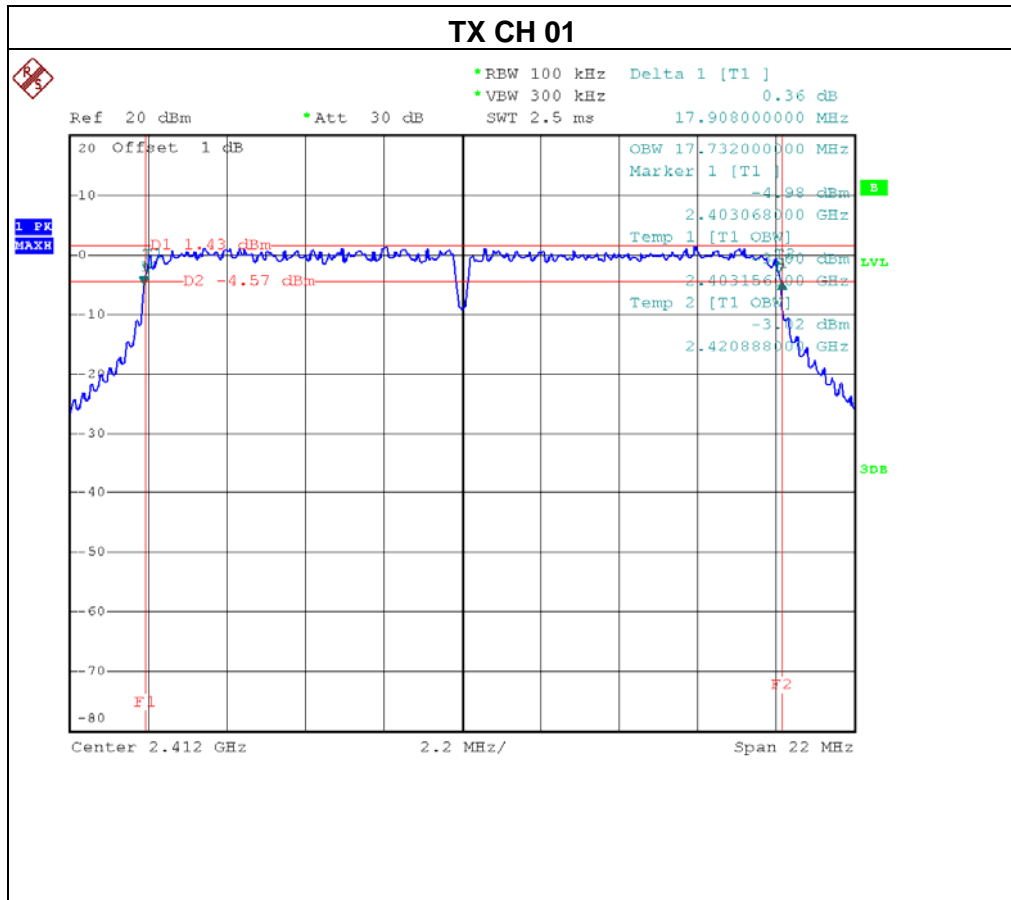

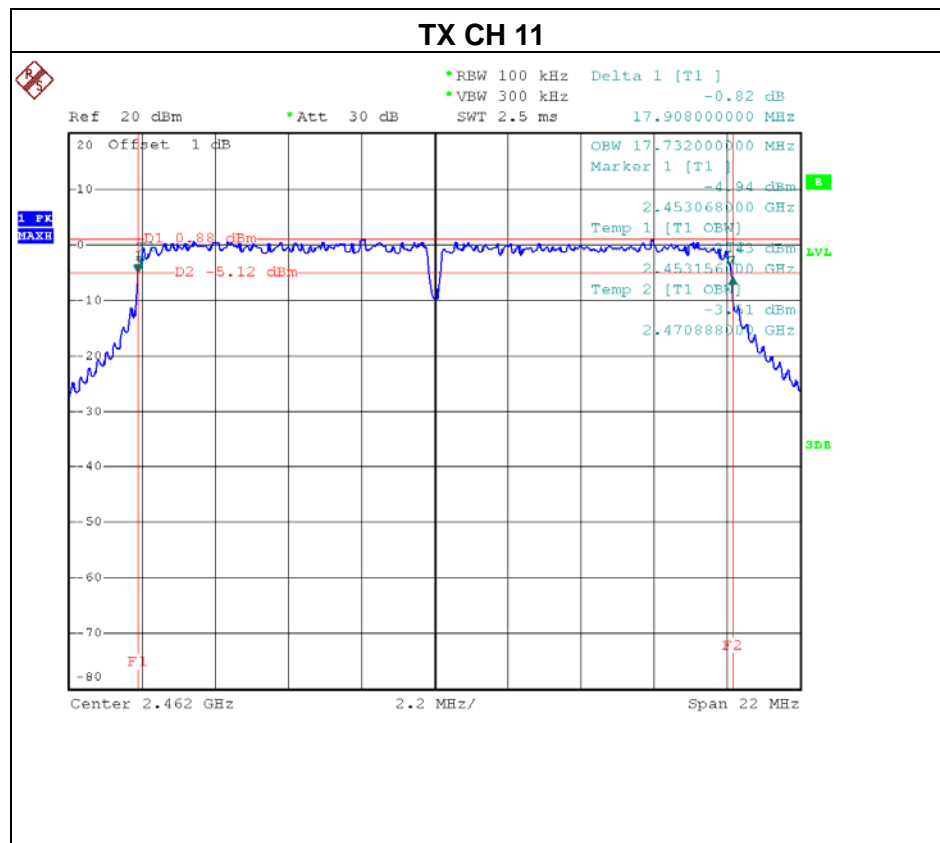
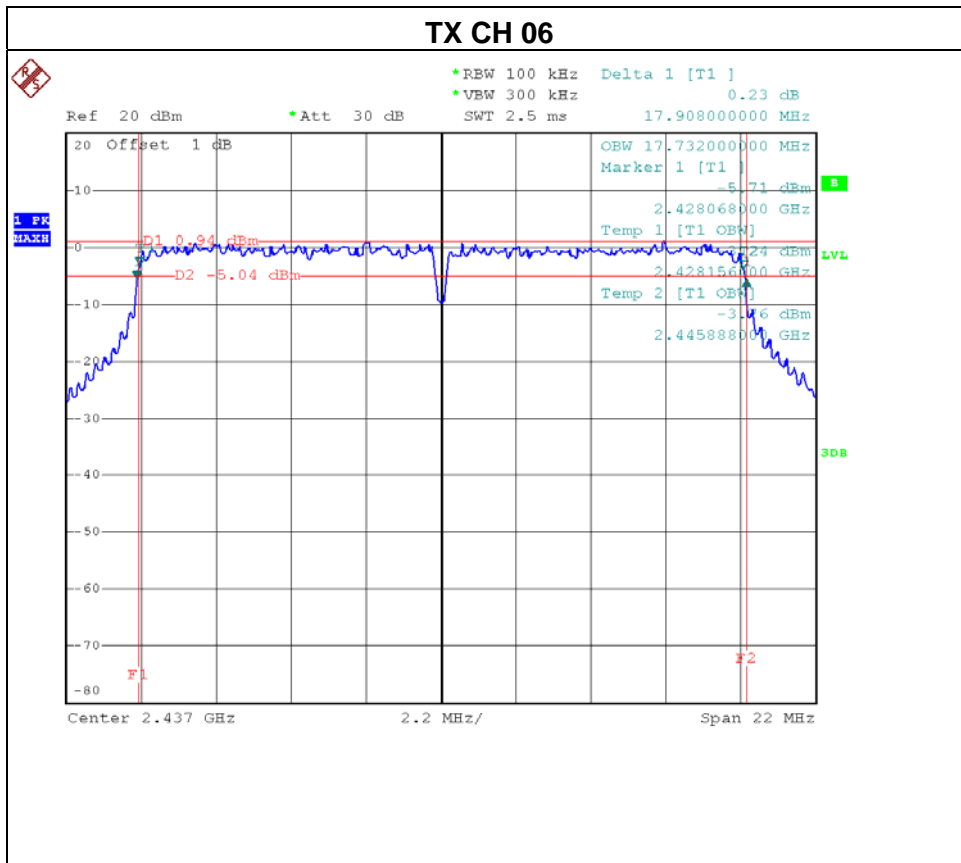



Test Mode : TX N-20MHz Mode-ANT 2				
Test Channel	Frequency (MHz)	Bandwidth (MHz)	99% Occupied Bandwidth (MHz)	Result
CH01	2412	17.82	17.73	PASS
CH06	2437	17.82	17.73	PASS
CH11	2462	17.82	17.73	PASS

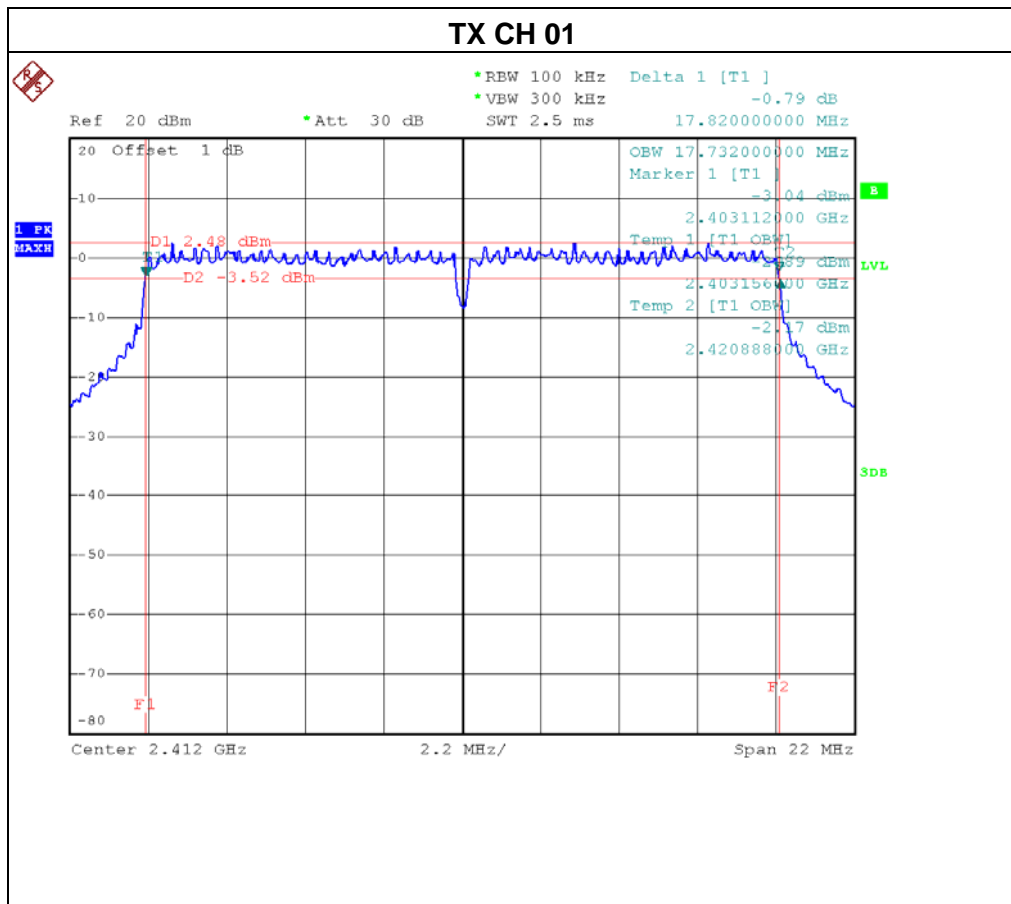

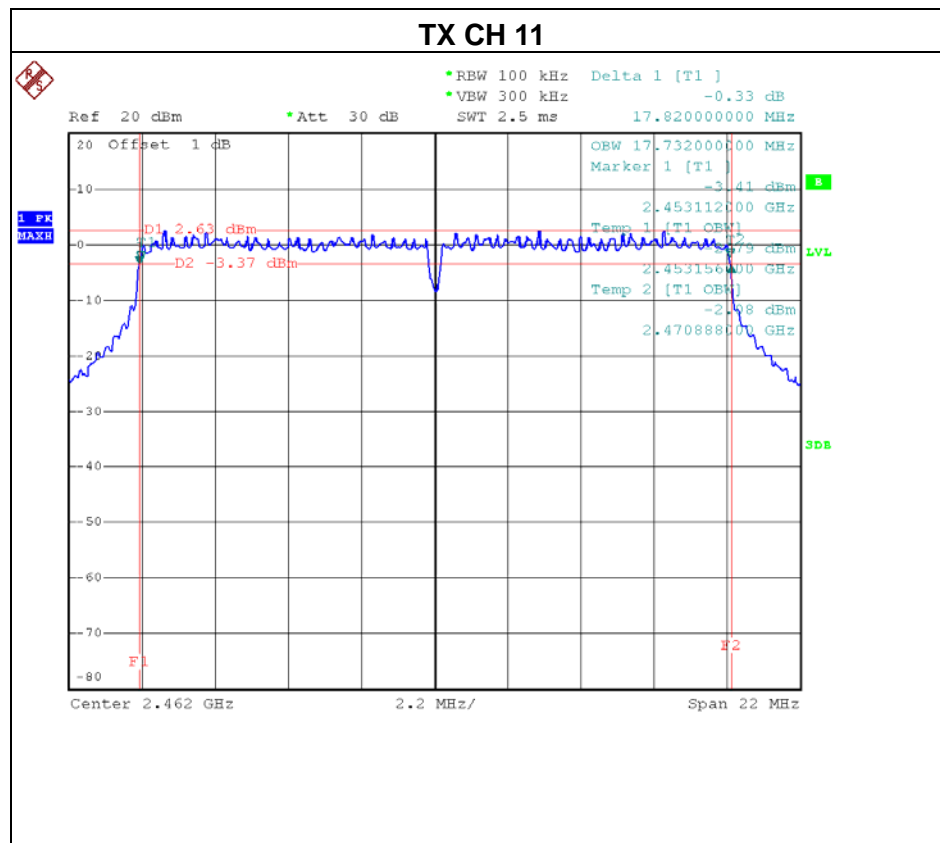
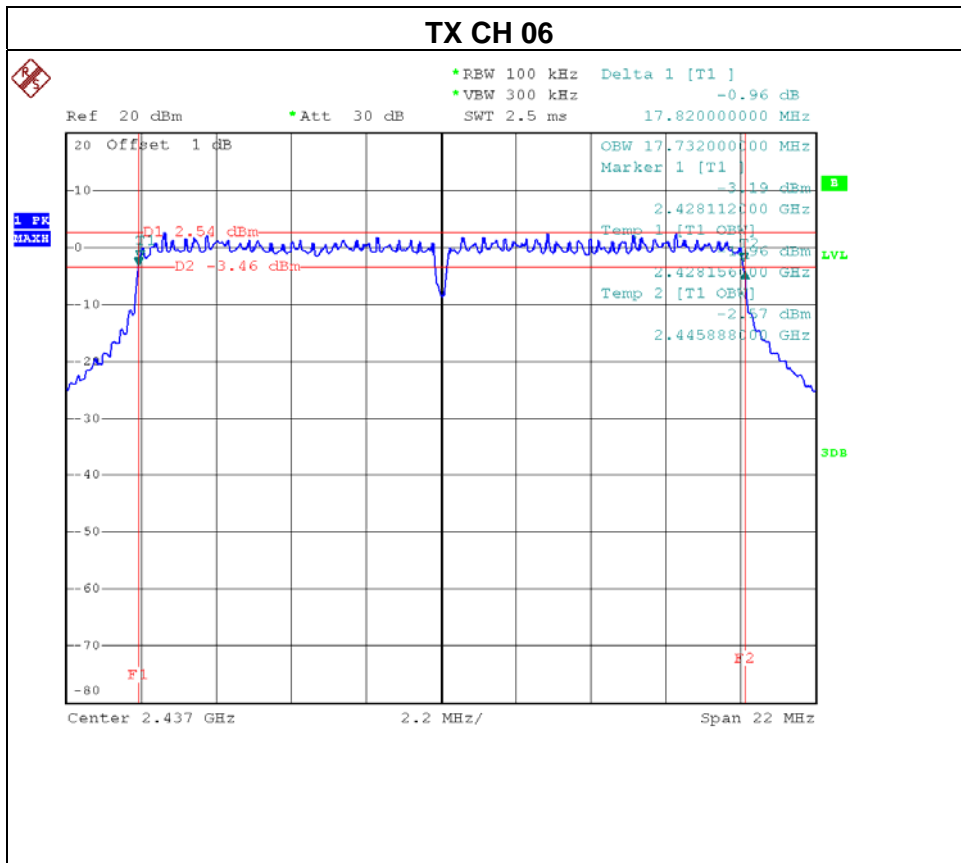



Test Mode : TX N-40MHz Mode-ANT 1				
Test Channel	Frequency (MHz)	Bandwidth (MHz)	99% Occupied Bandwidth (MHz)	Result
CH03	2422	36.60	36.20	PASS
CH06	2437	36.50	36.20	PASS
CH09	2452	36.60	36.20	PASS

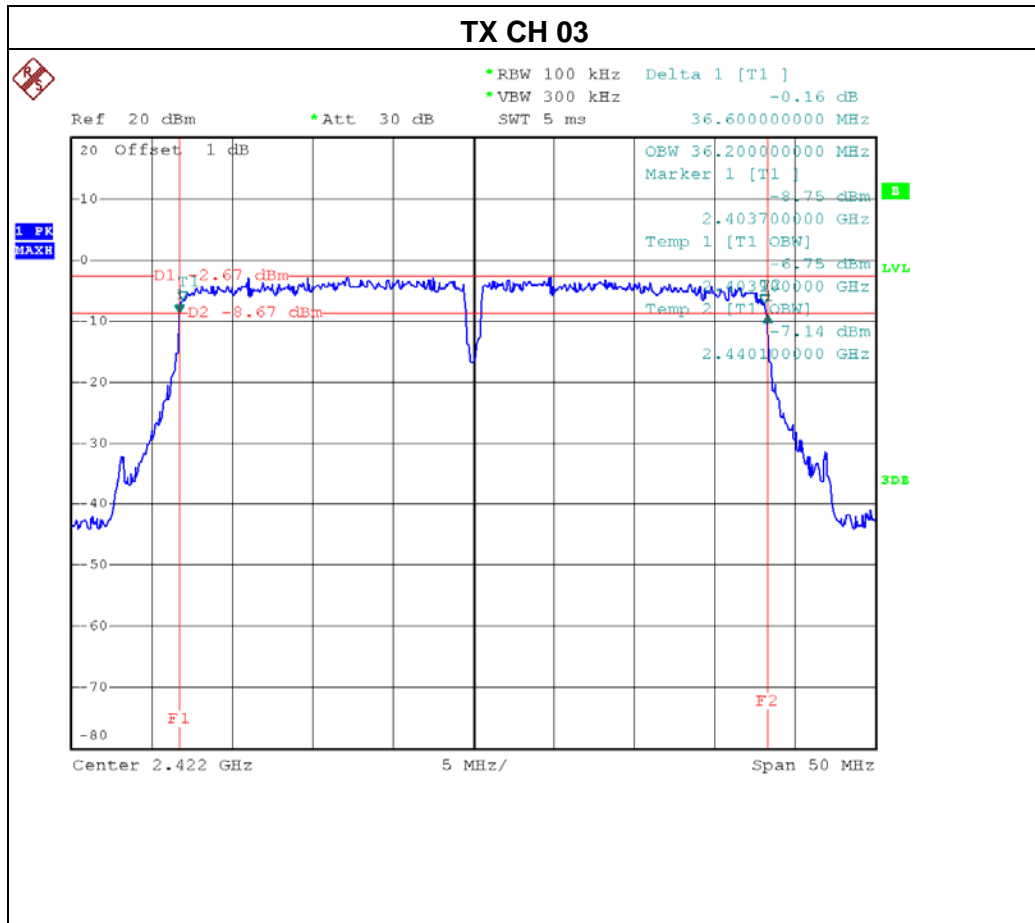

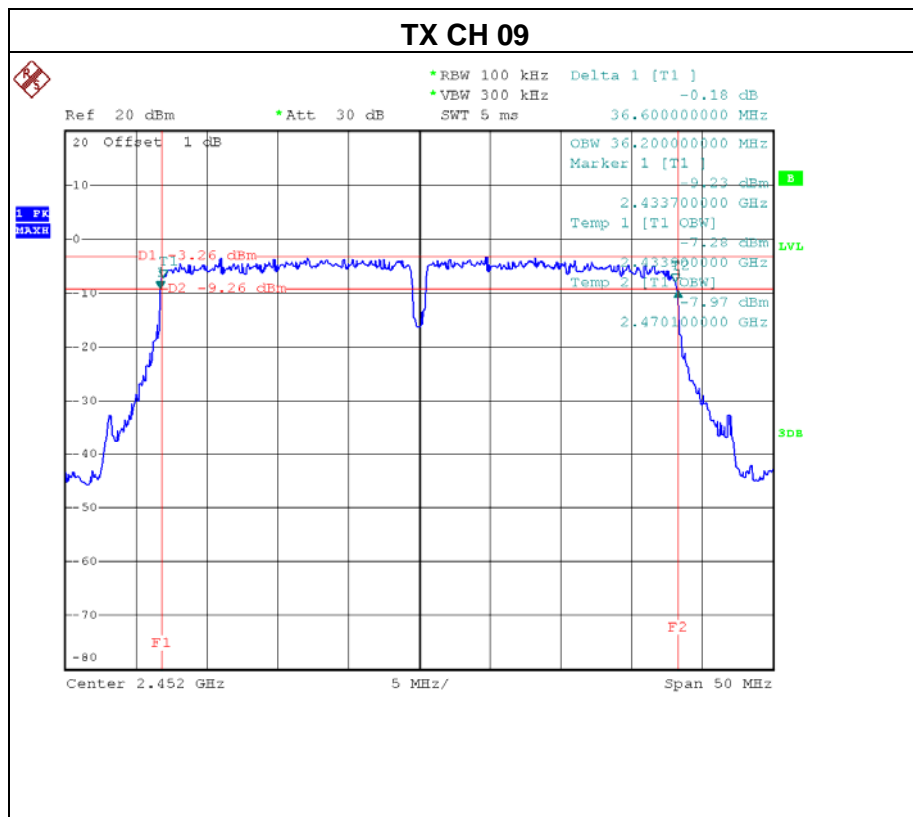
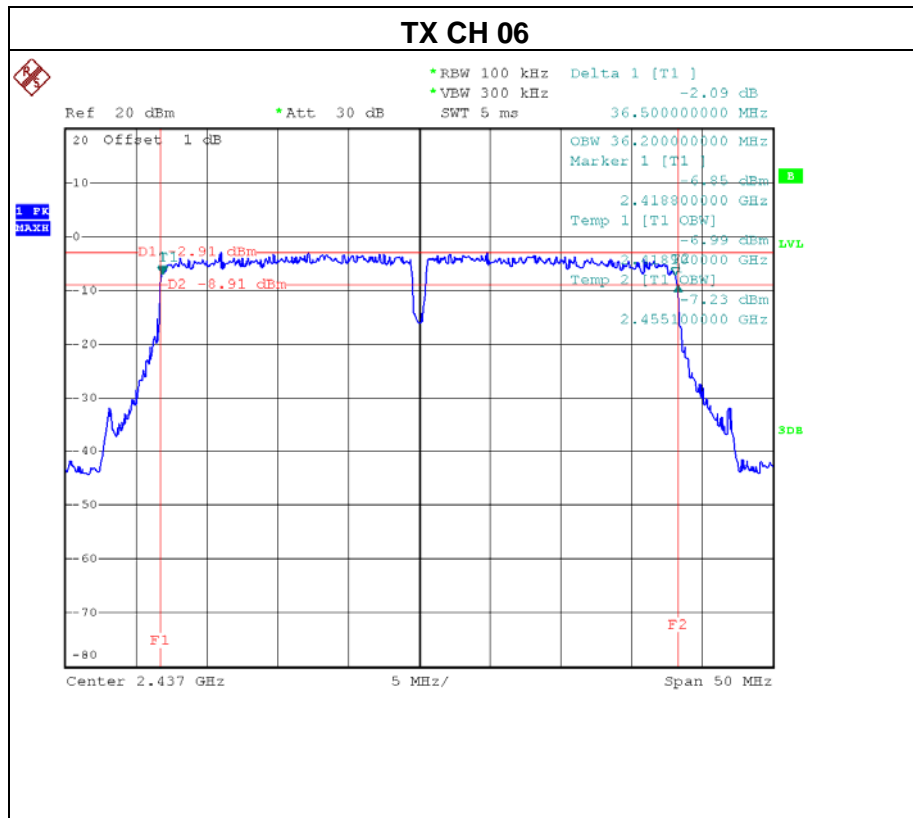



Test Mode : TX N-40MHz Mode-ANT 2				
Test Channel	Frequency (MHz)	Bandwidth (MHz)	99% Occupied Bandwidth (MHz)	Result
CH03	2422	36.50	36.30	PASS
CH06	2437	36.60	36.20	PASS
CH09	2452	36.60	36.30	PASS

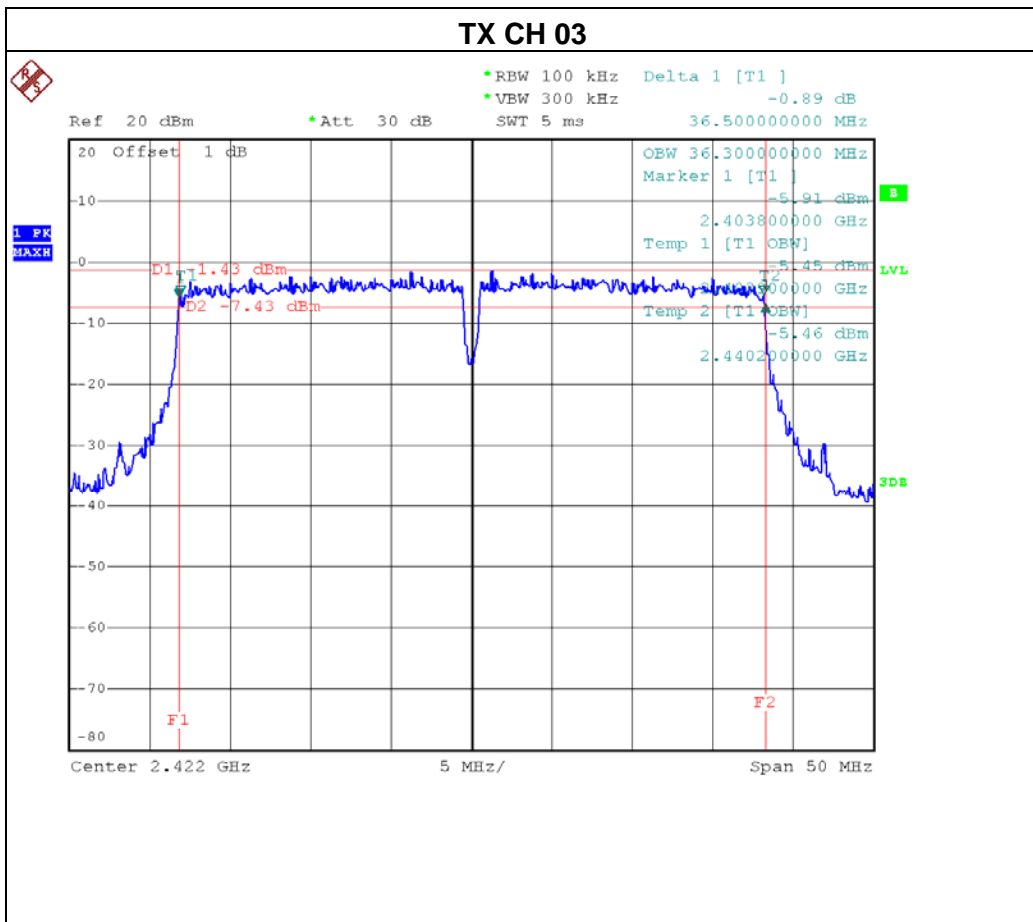

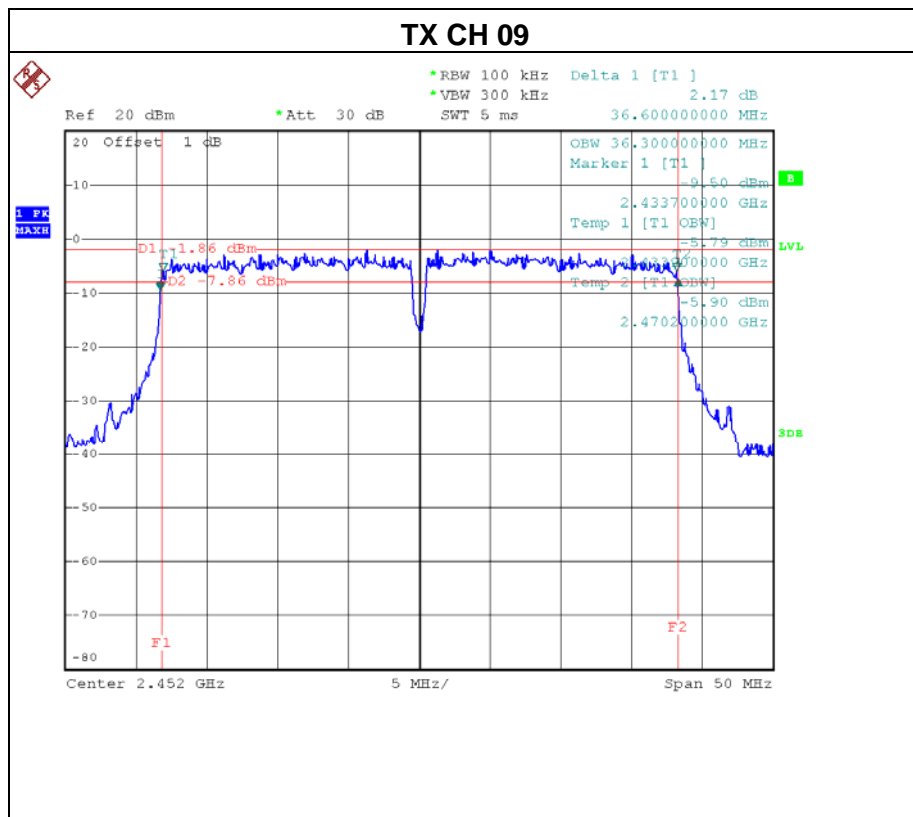
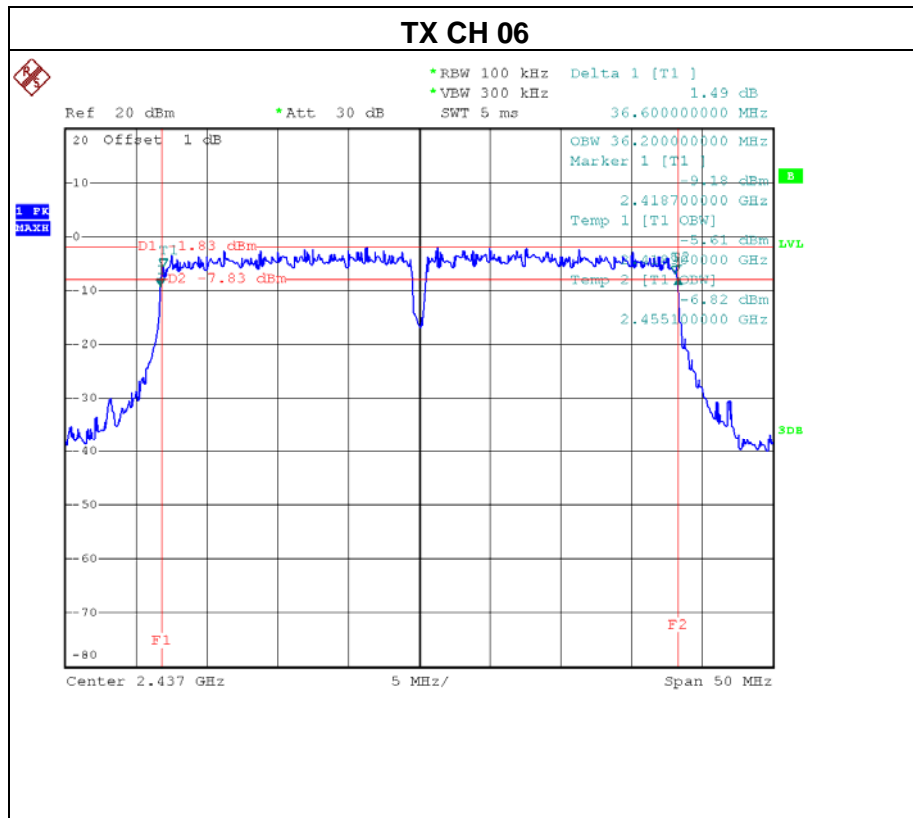



6. MAXIMUM OUTPUT POWER TEST

6.1 Applied procedures / limit

FCC Part15 (15.247) , Subpart C/ RSS-210				
Section	Test Item	Limit	Frequency Range (MHz)	Result
15.247(b)(3) RSS-210 Annex 8.4(4)	Maximum Output Power	1 Watt or 30dBm	2400-2483.5	PASS

6.1.1 TEST PROCEDURE

- a. The EUT was directly connected to the power meter and antenna output port as show in the block diagram below,
- b. The maximum peak conducted output power was performed in accordance with method 9.1.3 of FCC KDB 558074 D01 DTS Meas Guidance v03r01.

6.1.2 DEVIATION FROM STANDARD

No deviation.

6.1.3 TEST SETUP



6.1.4 EUT OPERATION CONDITIONS

The EUT tested system was configured as the statements of 4.1.6 Unless otherwise a special operating condition is specified in the follows during the testing. Transmit output power was measured while the host equipment supply voltage was varied from 85 % to 115 % of the nominal rated supply voltage. No change in transmit output power was observed.

6.1.5 EUT TEST CONDITIONS

Temperature: 25°C
 Relative Humidity: 55%
 Test Voltage: 120V/60Hz



6.1.6 TEST RESULTS

Test Mode : TX B Mode				
Test Channel	Frequency (MHz)	Output Power (dBm)	Limit (dBm)	Limit (Watt)
CH01	2412	16.81	30	1
CH06	2437	16.82	30	1
CH11	2462	16.81	30	1

Test Mode : TX G Mode				
Test Channel	Frequency (MHz)	Output Power (dBm)	Limit (dBm)	Limit (Watt)
CH01	2412	24.12	30	1
CH06	2437	24.32	30	1
CH11	2462	24.41	30	1



Test Mode : TX N-20M Mode-ANT 1

Test Channel	Frequency (MHz)	Output Power (dBm)	Limit (dBm)	Limit (Watt)
CH01	2412	22.84	30	1
CH06	2437	22.92	30	1
CH11	2462	23.19	30	1

Test Mode : TX N-20M Mode-ANT 2

Test Channel	Frequency (MHz)	Output Power (dBm)	Limit (dBm)	Limit (Watt)
CH01	2412	22.85	30	1
CH06	2437	22.91	30	1
CH11	2462	23.12	30	1

Test Mode : TX N-20M Mode-Total

Test Channel	Frequency (MHz)	Output Power (dBm)	Limit (dBm)	Limit (Watt)
CH01	2412	25.86	30	1
CH06	2437	25.93	30	1
CH11	2462	26.17	30	1



Test Mode : TX N-40M Mode-ANT 1				
Test Channel	Frequency (MHz)	Output Power (dBm)	Limit (dBm)	Limit (Watt)
CH03	2422	19.81	30	1
CH06	2437	19.86	30	1
CH09	2452	19.97	30	1

Test Mode : TX N-40M Mode-ANT 2				
Test Channel	Frequency (MHz)	Output Power (dBm)	Limit (dBm)	Limit (Watt)
CH03	2422	19.78	30	1
CH06	2437	19.82	30	1
CH09	2452	19.73	30	1

Test Mode : TX N-40M Mode-Total				
Test Channel	Frequency (MHz)	Output Power (dBm)	Limit (dBm)	Limit (Watt)
CH03	2422	22.81	30	1
CH06	2437	22.85	30	1
CH09	2452	22.86	30	1



7. ANTENNA CONDUCTED SPURIOUS EMISSION

7.1 Applied procedures / limit

20dB in any 100 KHz bandwidth outside the operating frequency band, In case the emission fall within the restricted band specified on 15.205(a) & RSS-210 section 2.2& Annex 8 (A8.5), then the 15.209(a) & RSS-GEN limit in the table below has to be followed.

Frequency (MHz)	Field Strength (microvolts/meter)	Measurement Distance (meters)
0.009~0.490	2400/F(KHz)	300
0.490~1.705	24000/F(KHz)	30
1.705~30.0	30	30
30~88	100	3
88~216	150	3
216~960	200	3
960~1000	500	3

LIMITS OF RADIATED EMISSION MEASUREMENT (Above 1000MHz)

Frequency (MHz)	(dBuV/m) (at 3 meters)	
	Peak	Average
Above 1000	74	54

7.1.1 TEST PROCEDURE

- a. The EUT was directly connected to the spectrum analyzer and antenna output port as show in the block diagram below,
- b. Spectrum Setting: RBW= 100KHz, VBW=300KHz, Sweep time = Auto.

7.1.2 DEVIATION FROM STANDARD

No deviation.

7.1.3 TEST SETUP

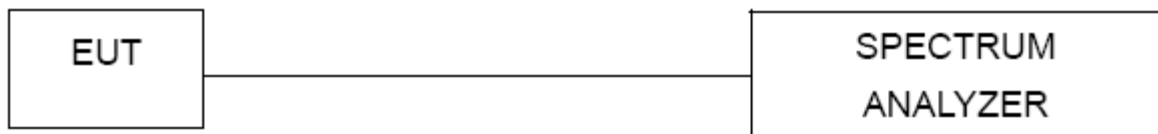

7.1.4 EUT OPERATION CONDITIONS

The EUT tested system was configured as the statements of 4.1.6 Unless otherwise a special operating condition is specified in the follows during the testing.

7.1.5 EUT TEST CONDITIONS

Temperature: 25°C
 Relative Humidity: 55%
 Test Voltage: 120V/60Hz



7.1.6 TEST RESULTS

Test Mode :	TX B Mode
--------------------	------------------

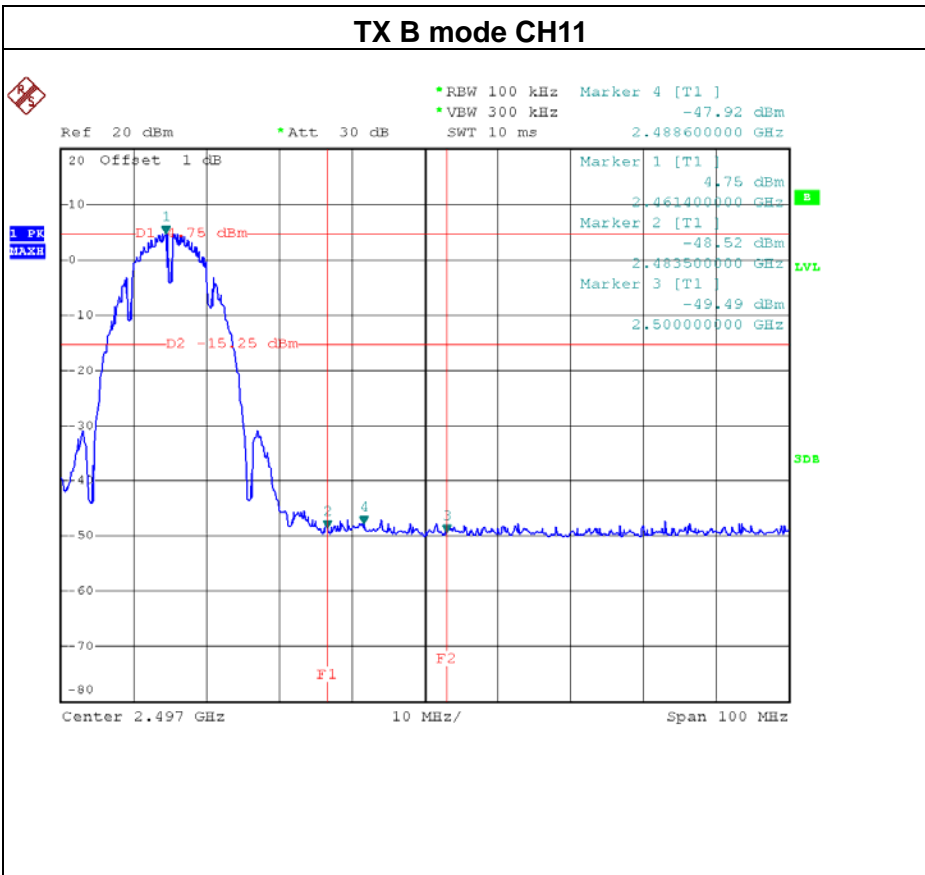
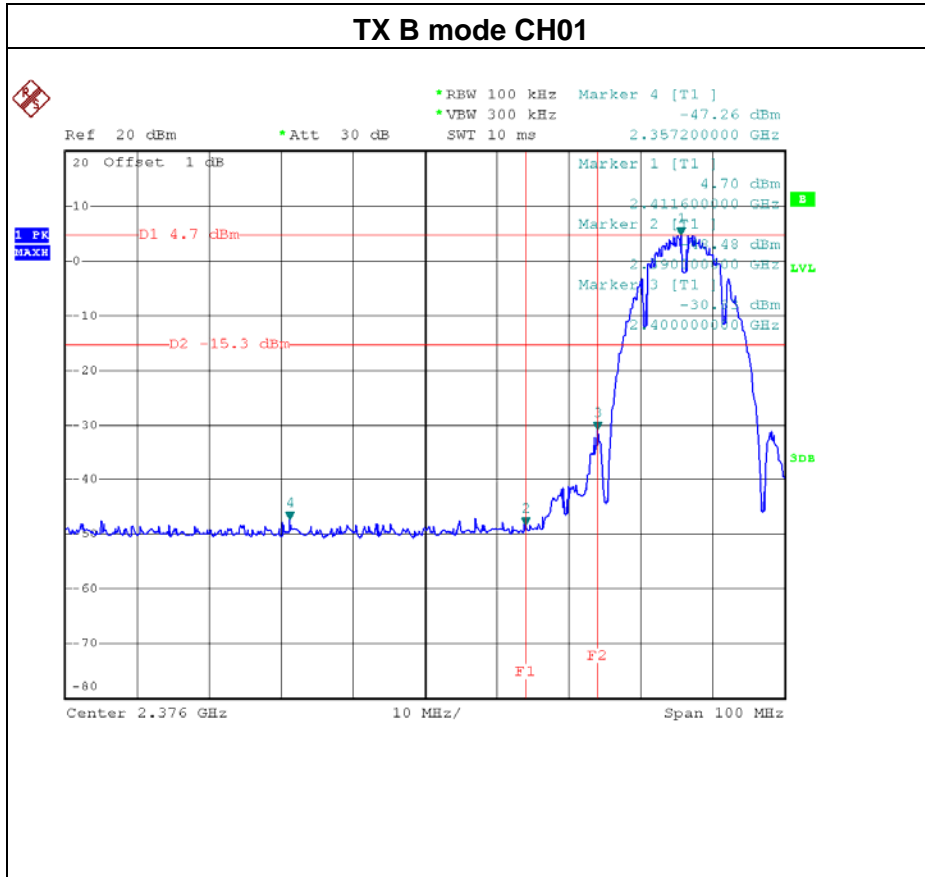

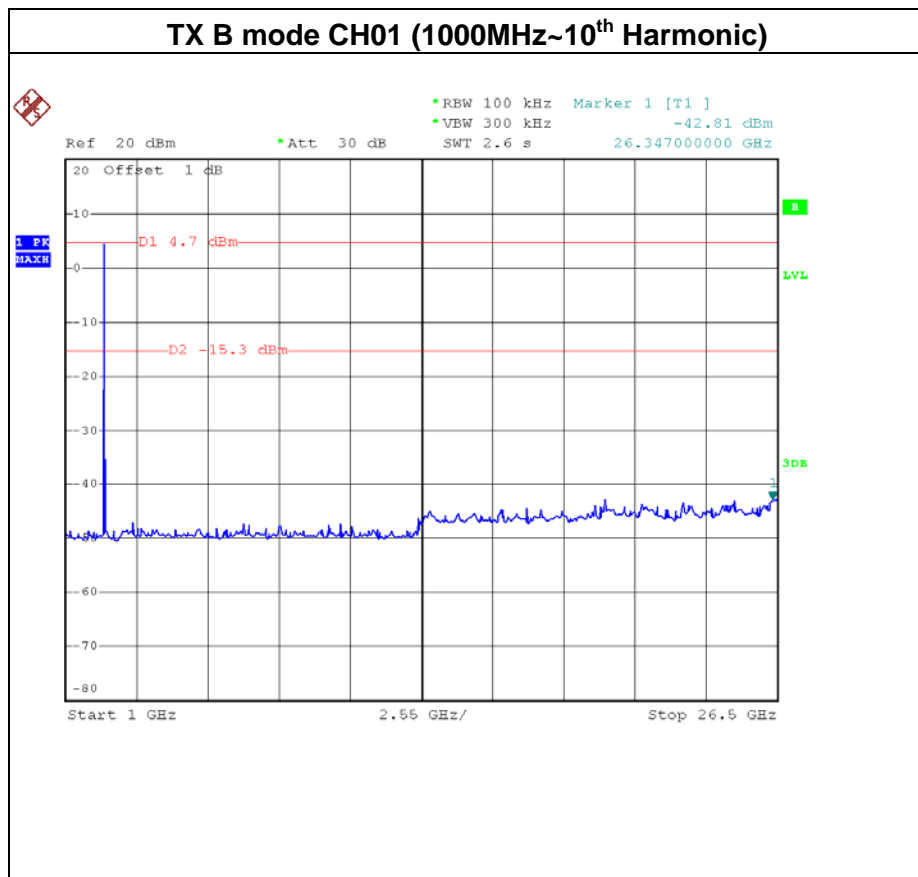
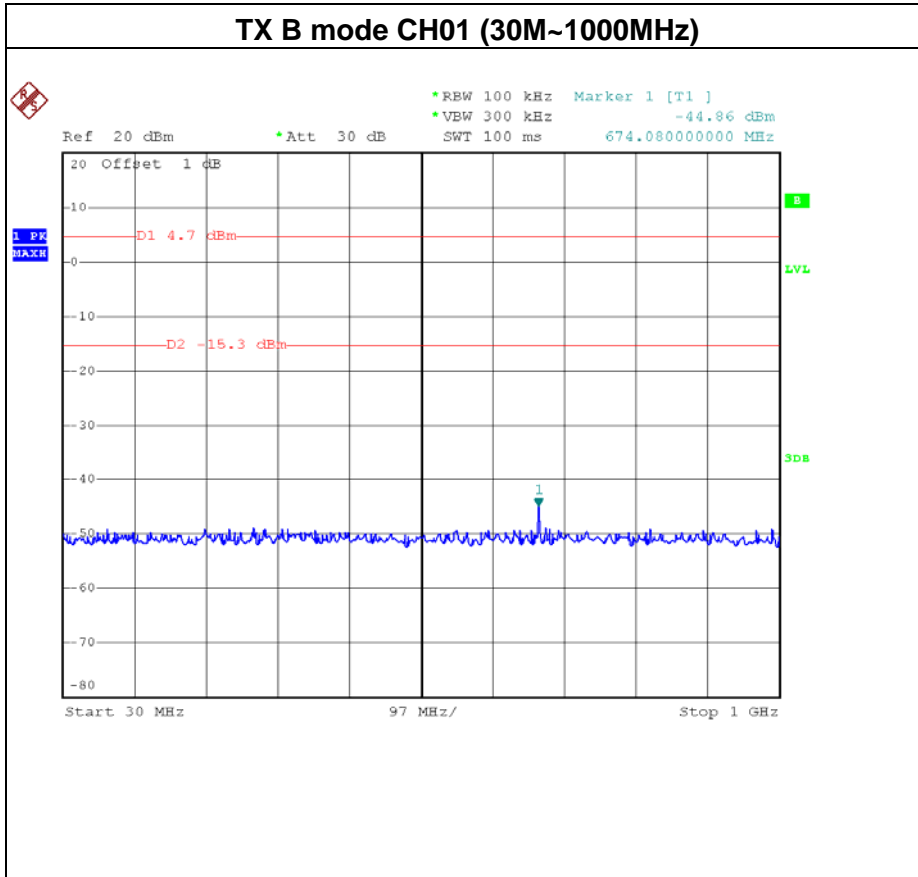

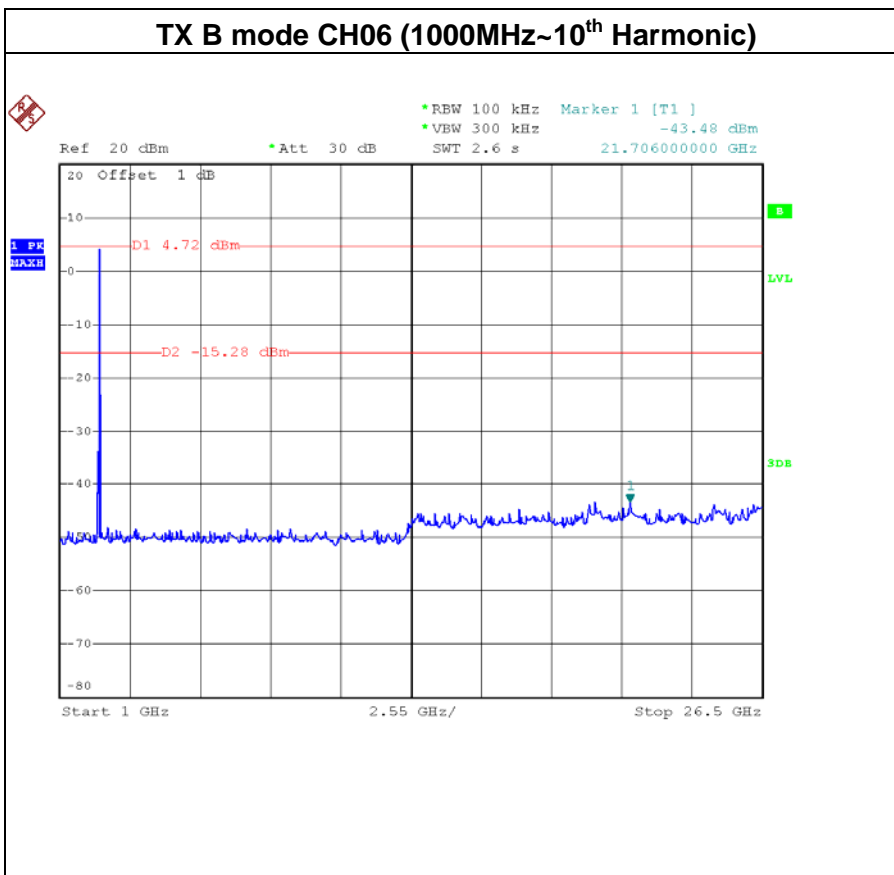
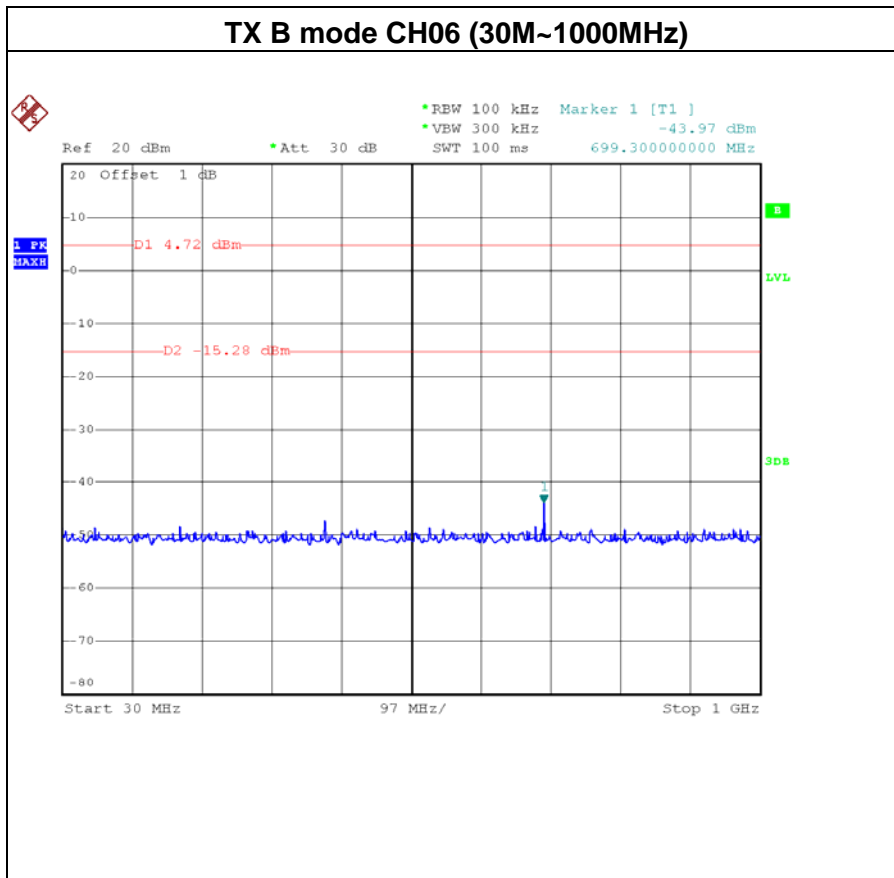

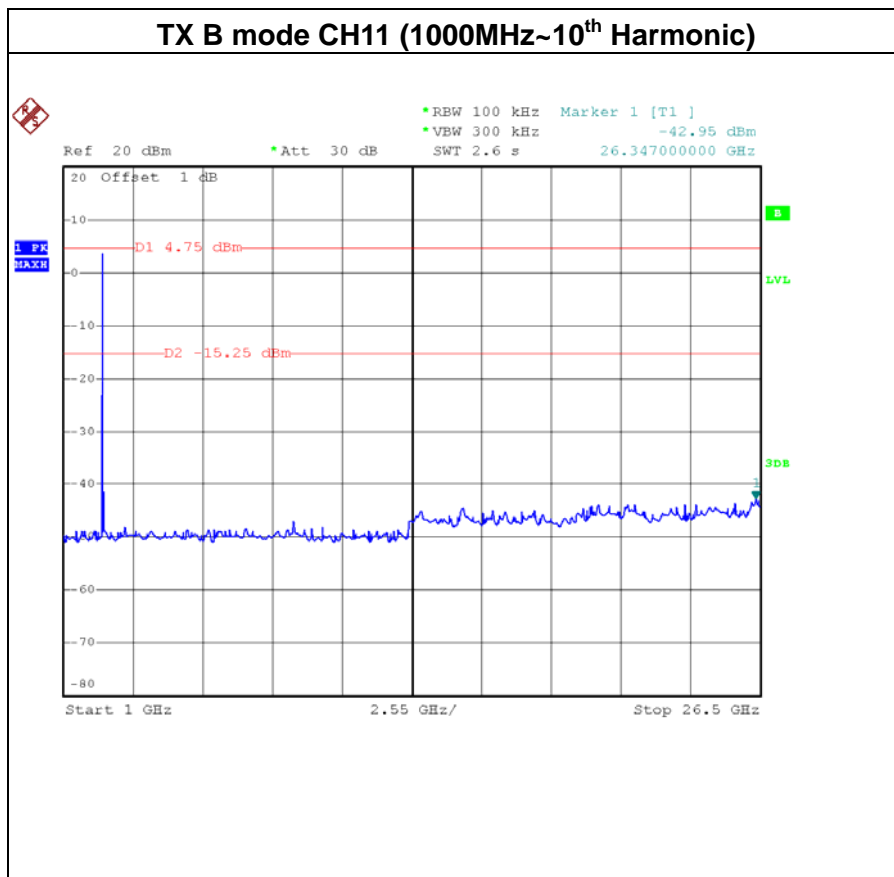
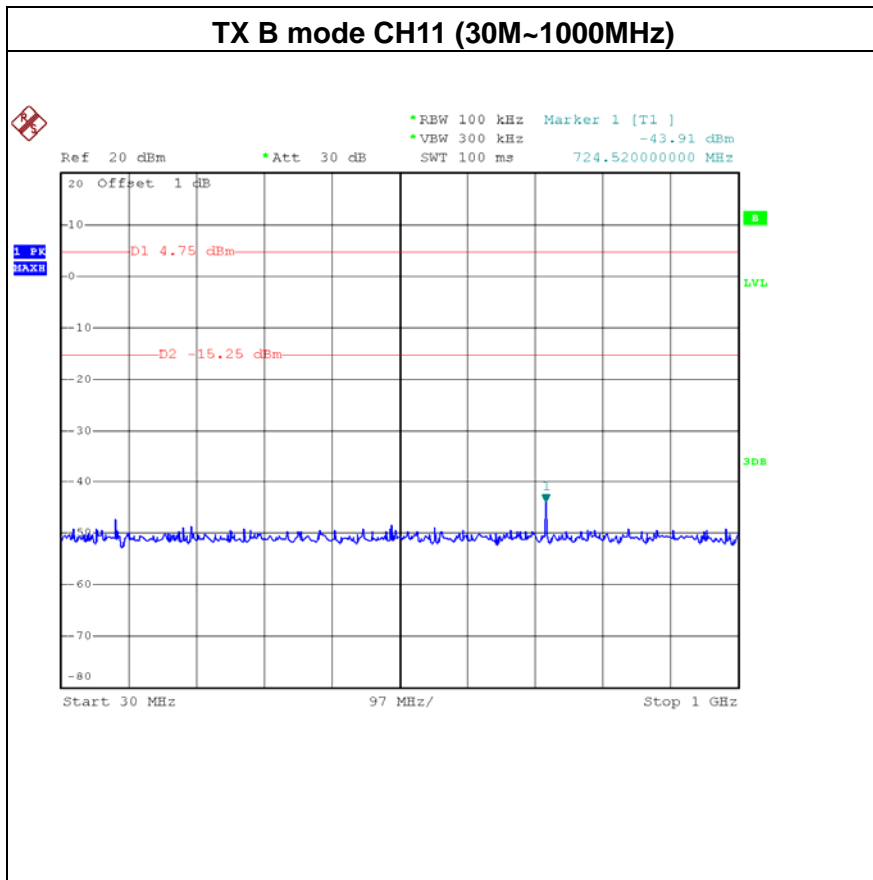



Test Mode :	TX G Mode
-------------	-----------

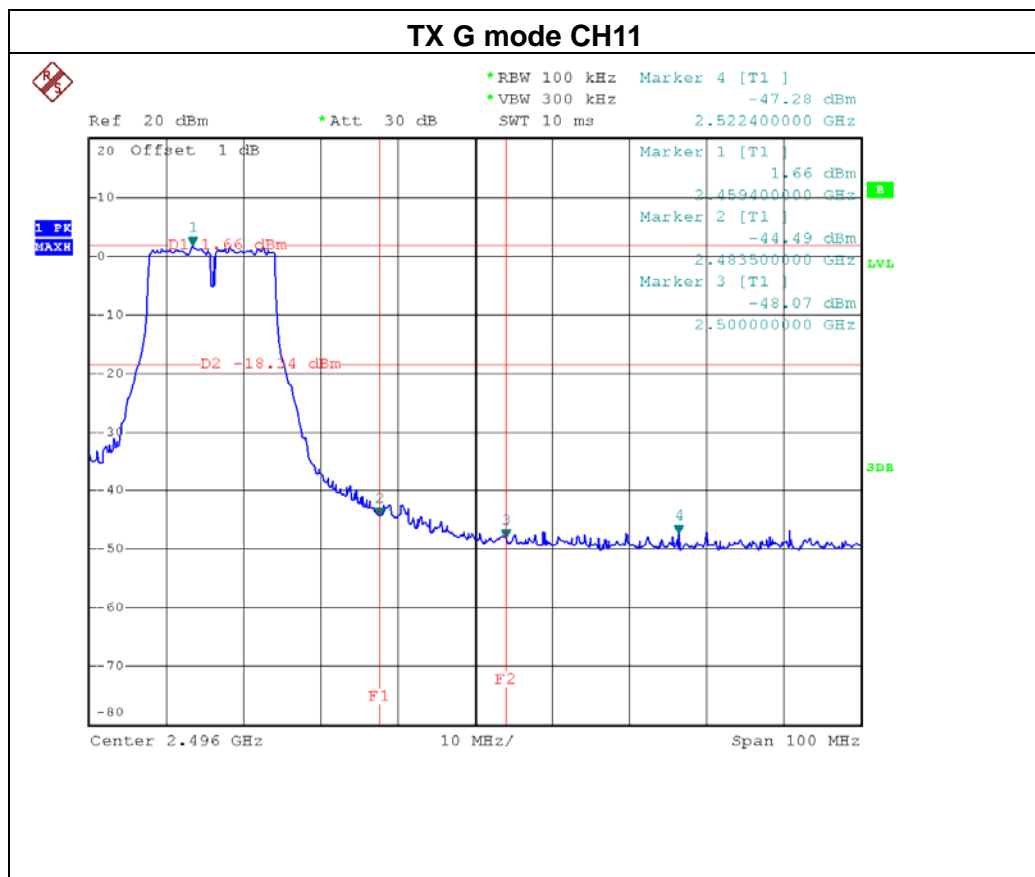
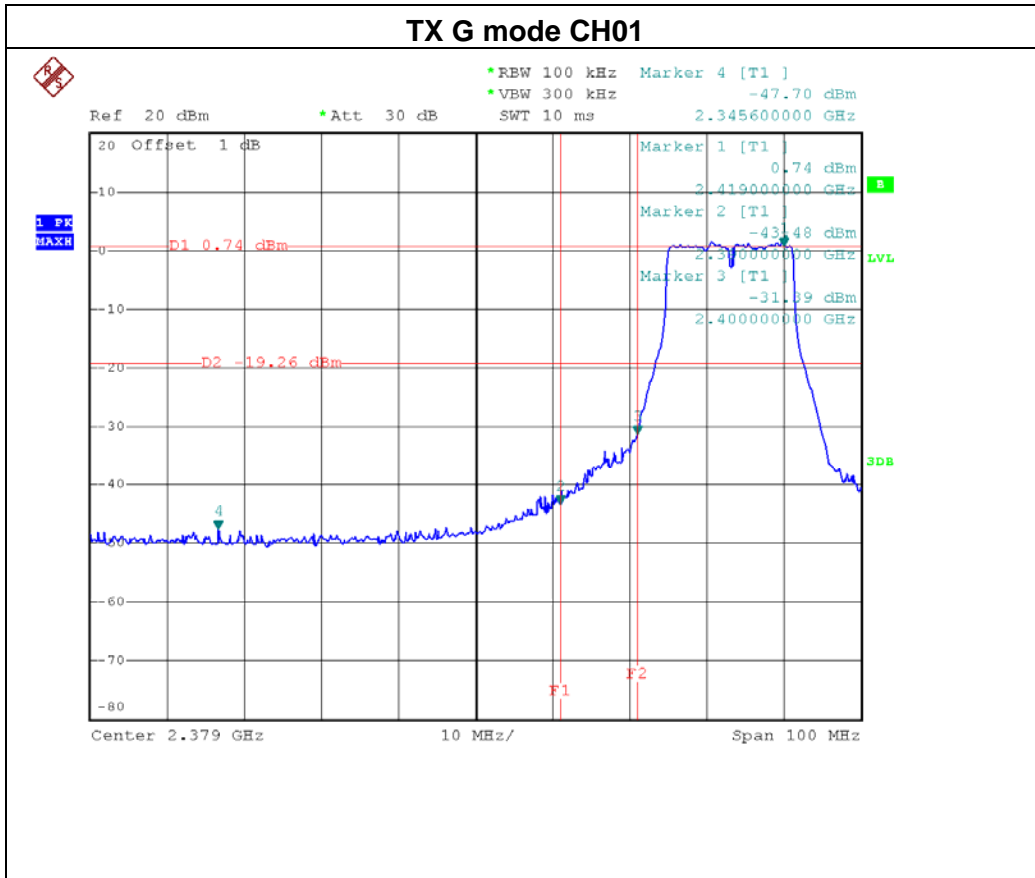

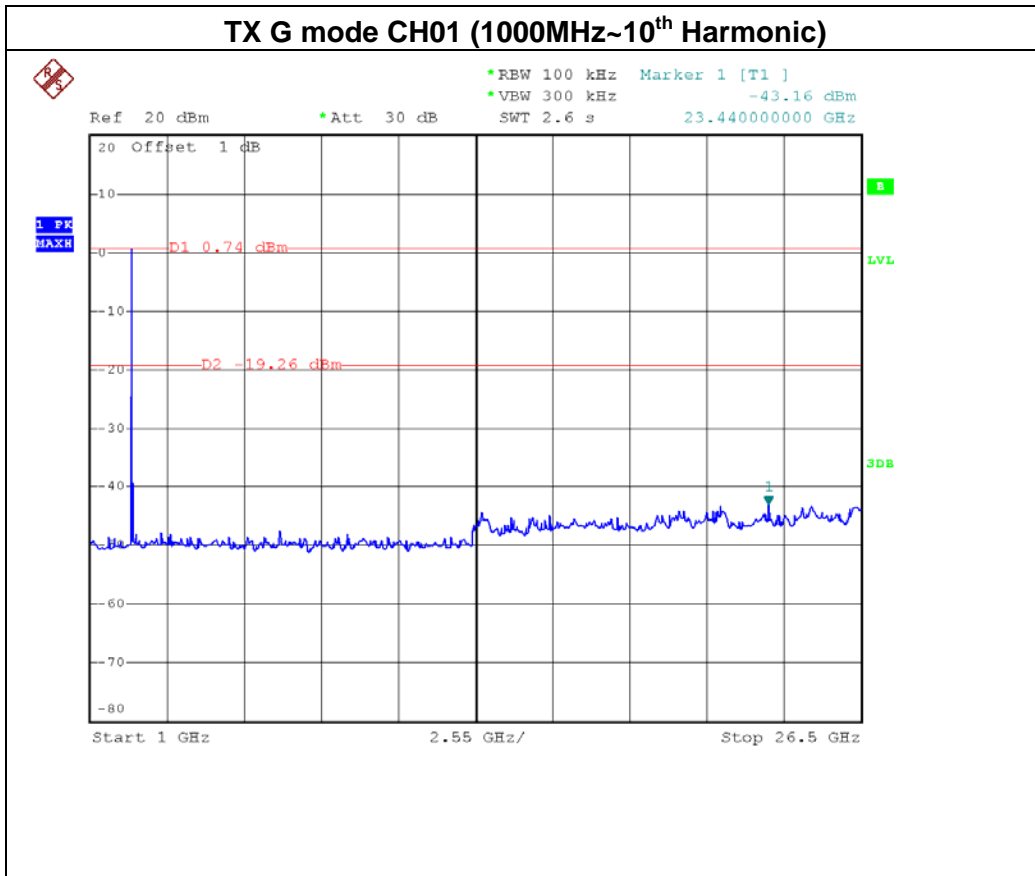
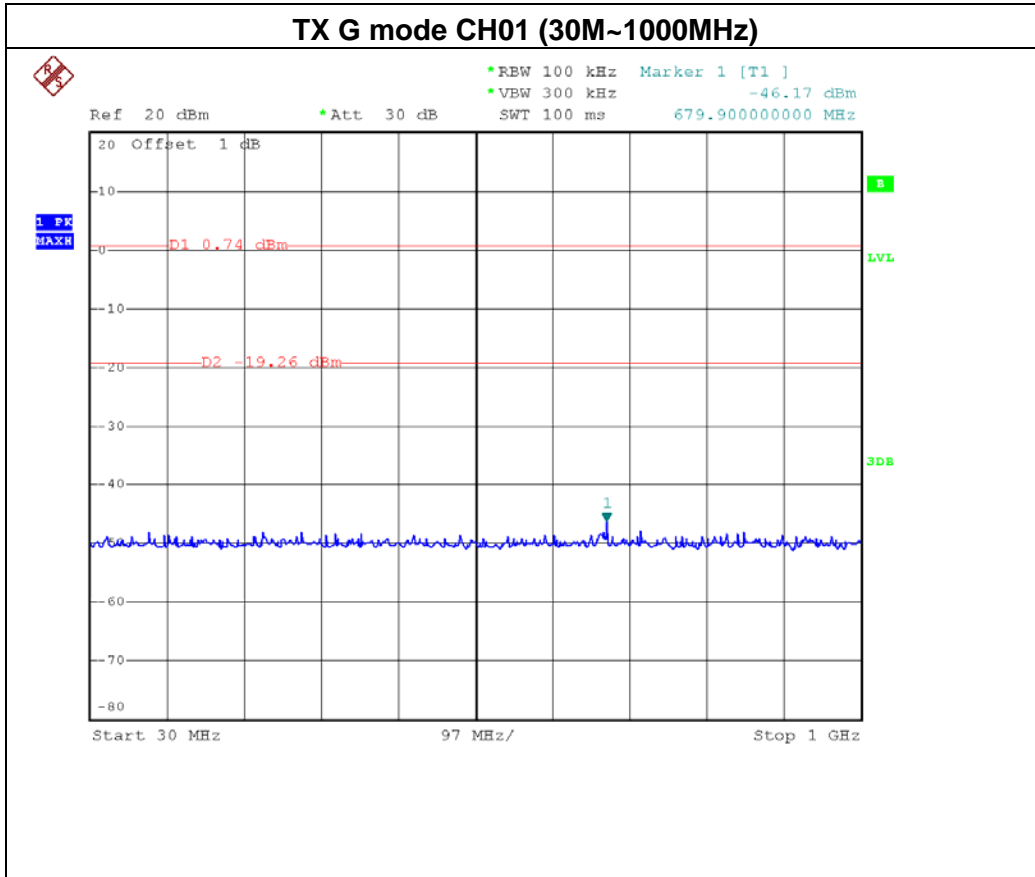

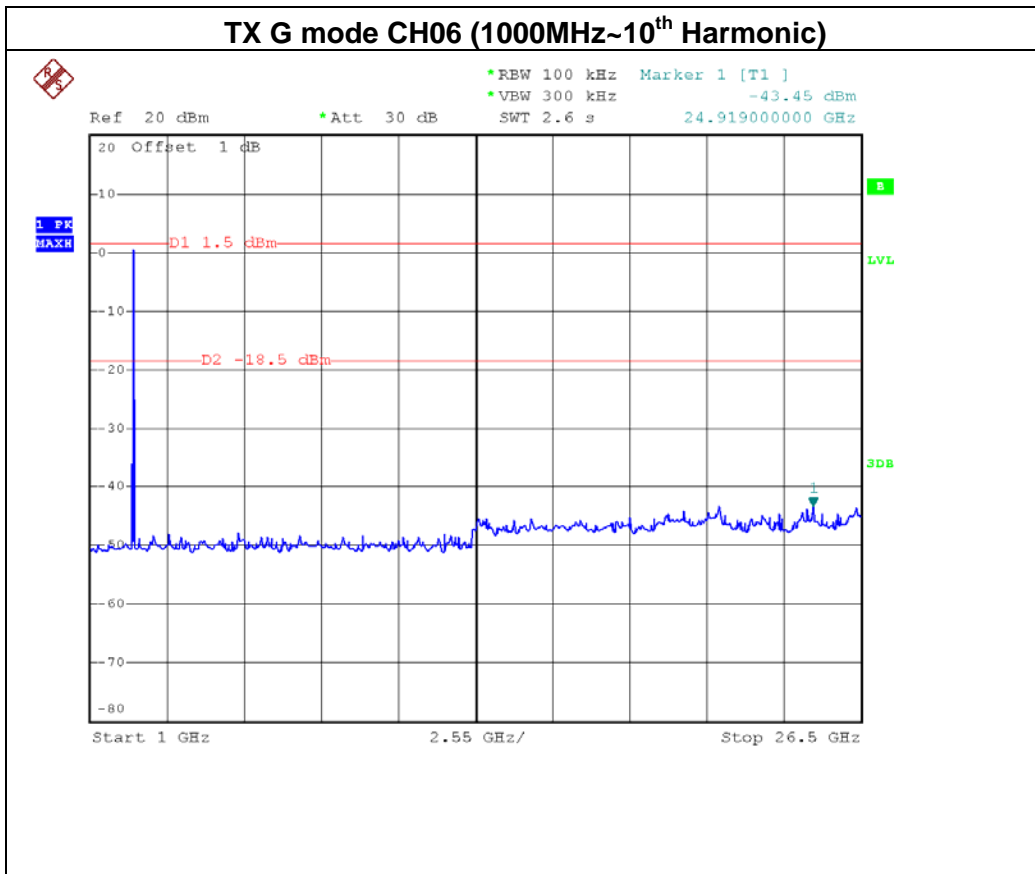
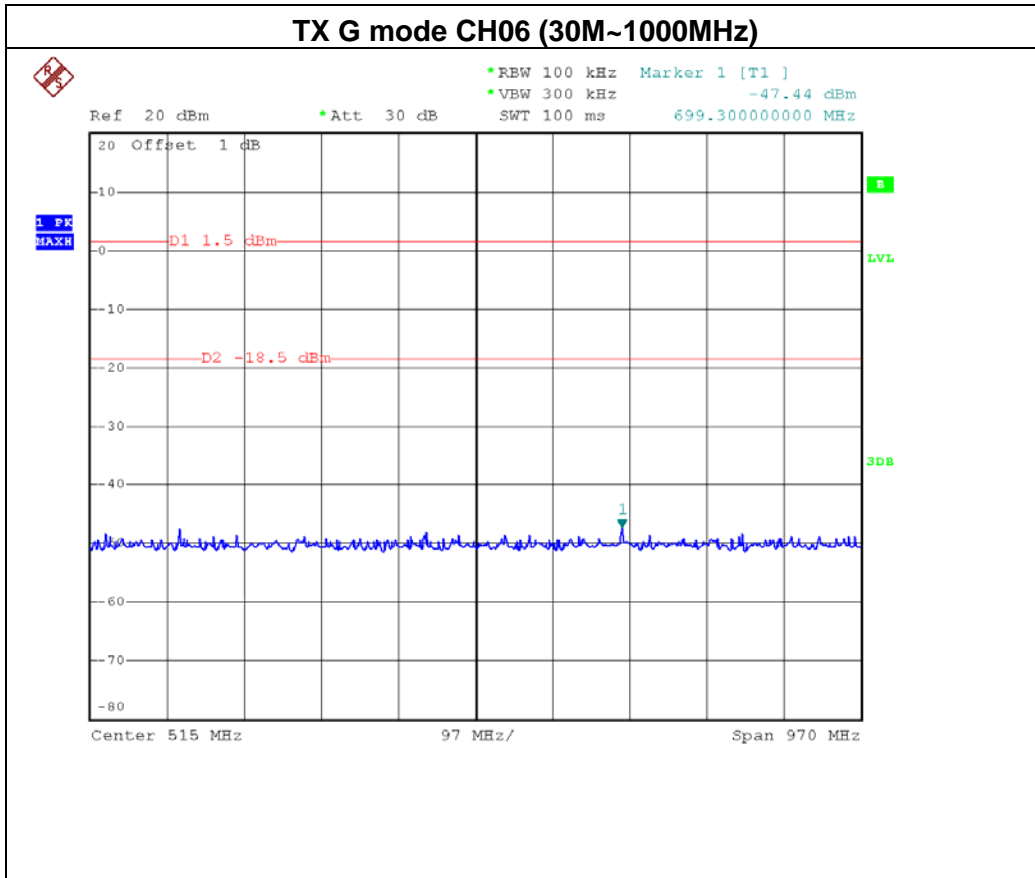

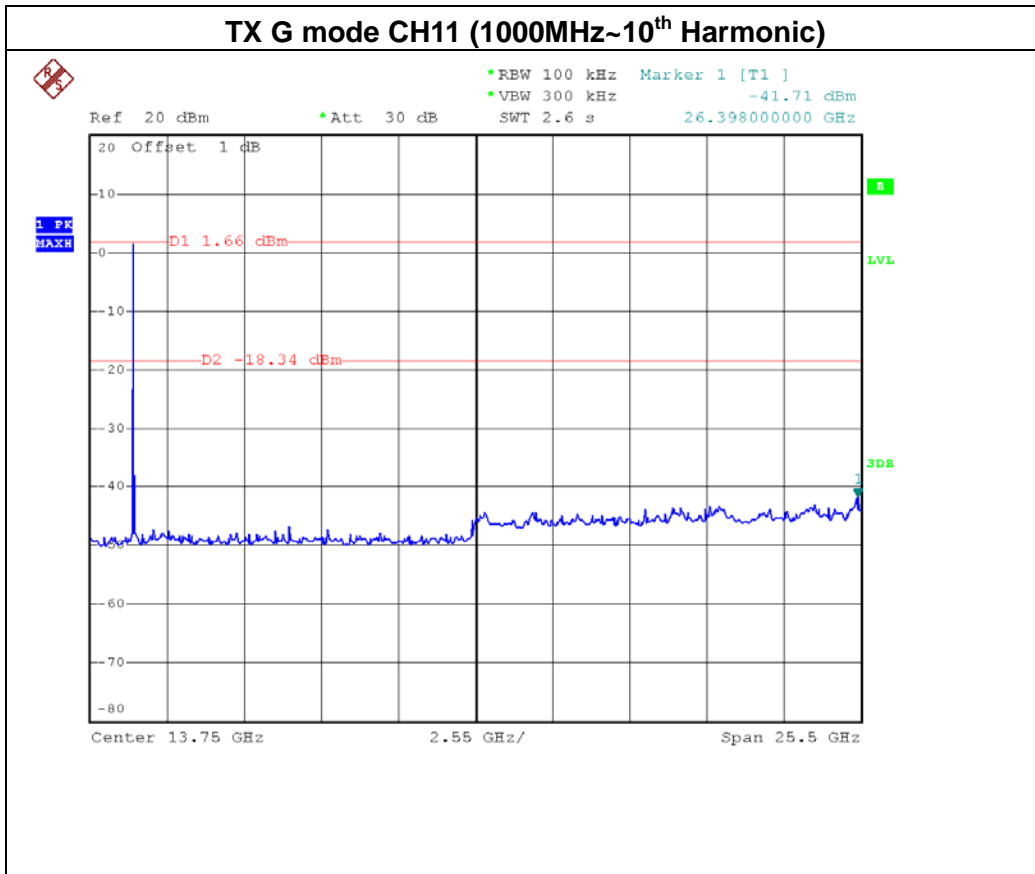
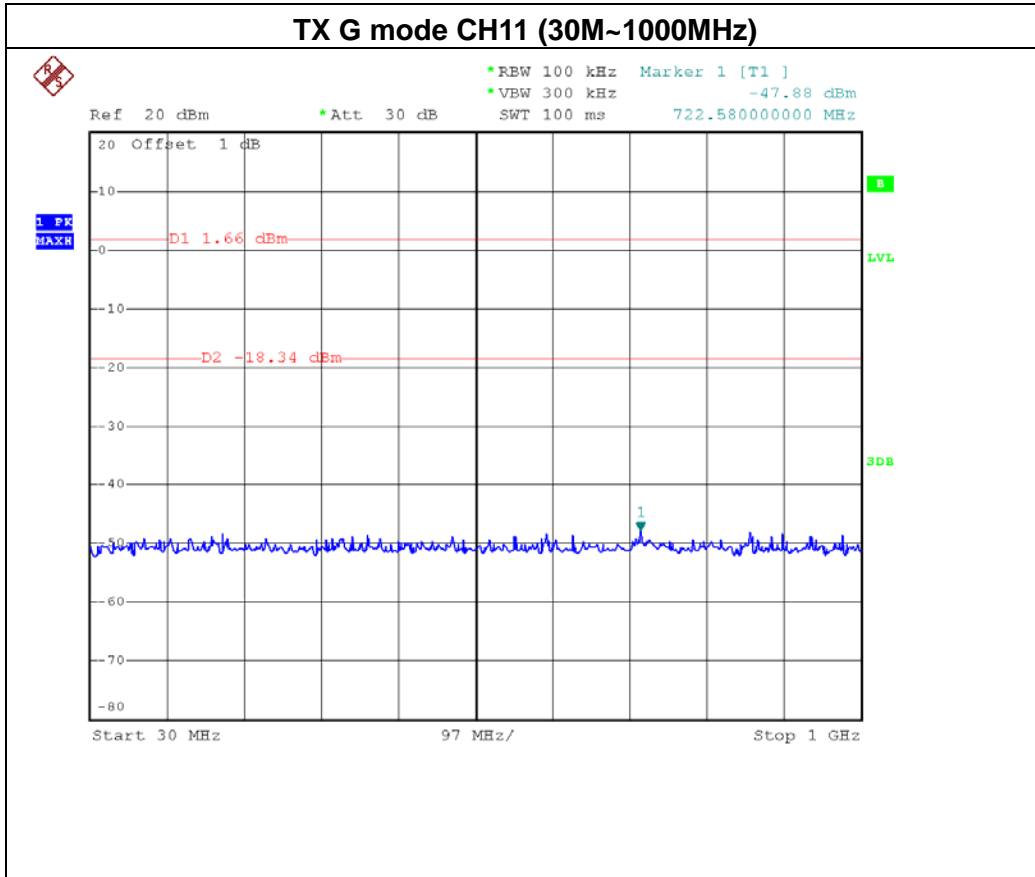



Test Mode :	TX N-20M Mode-ANT 1
--------------------	----------------------------

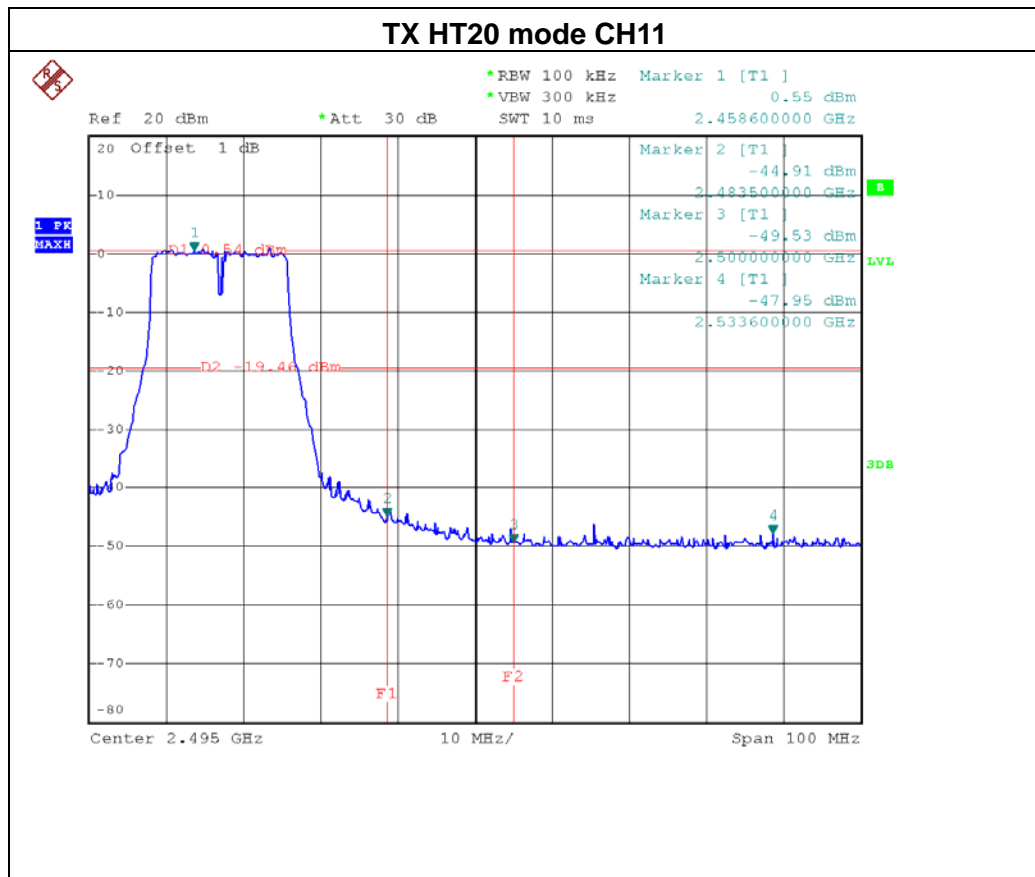
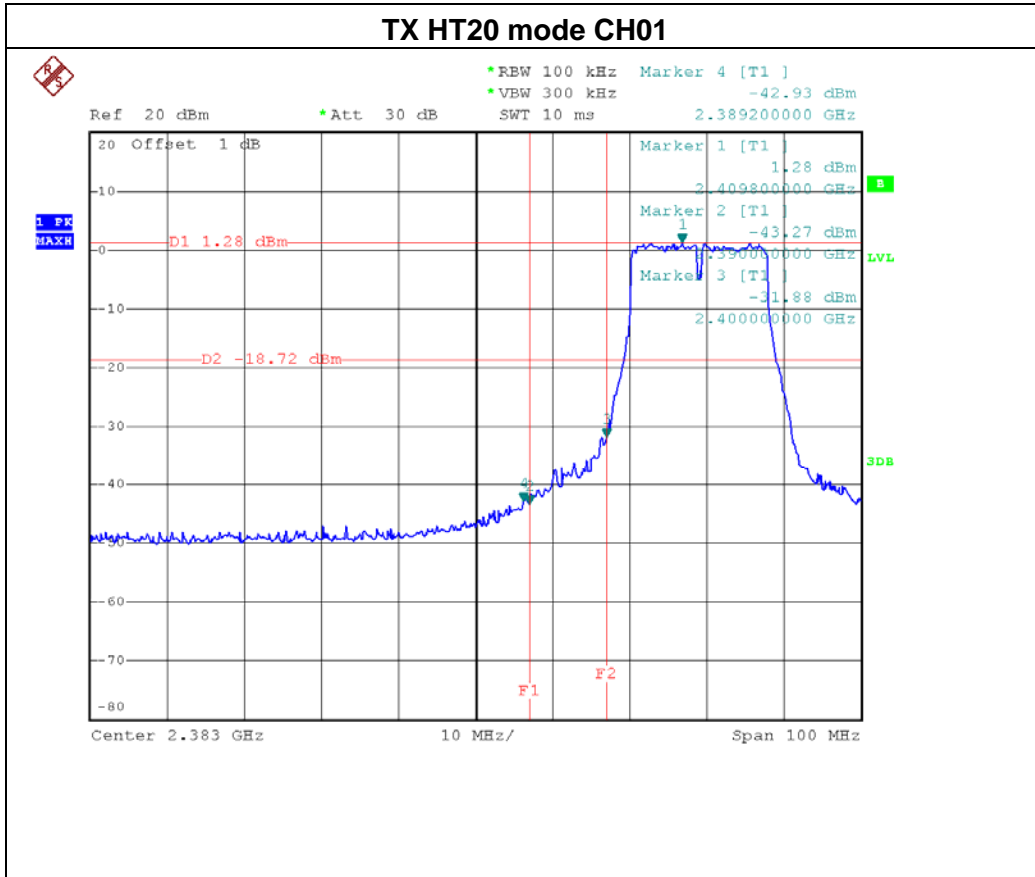

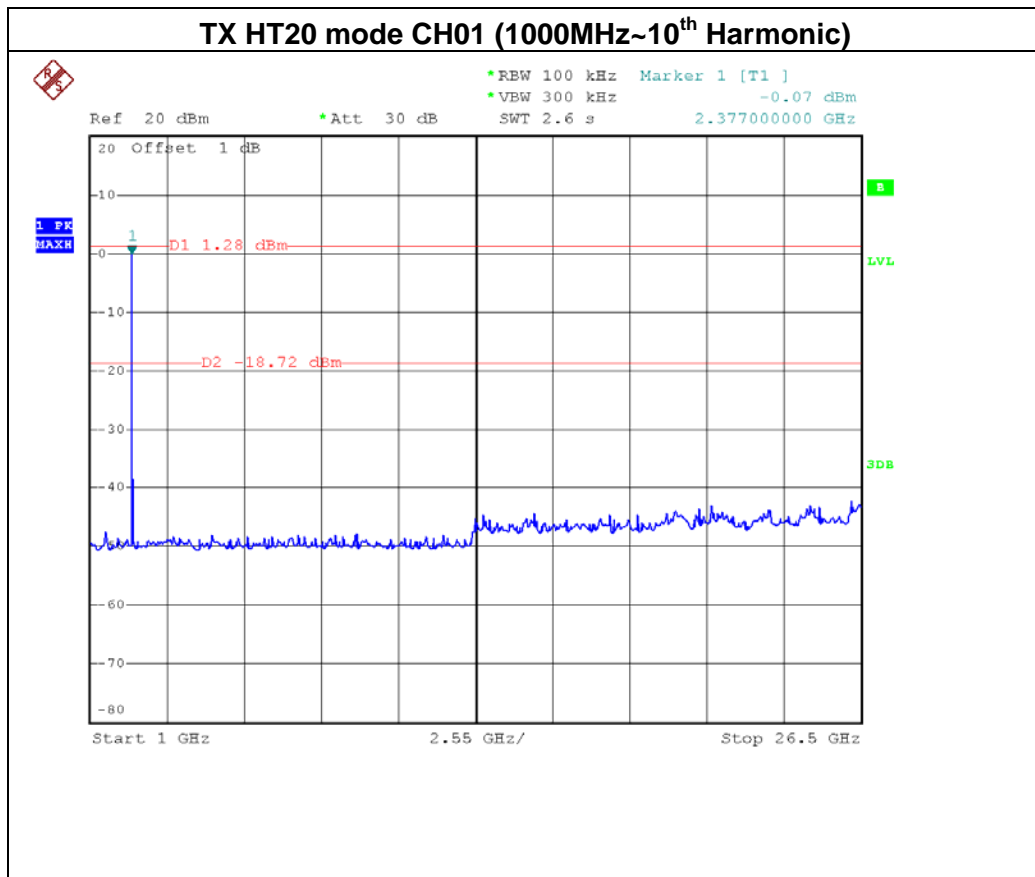
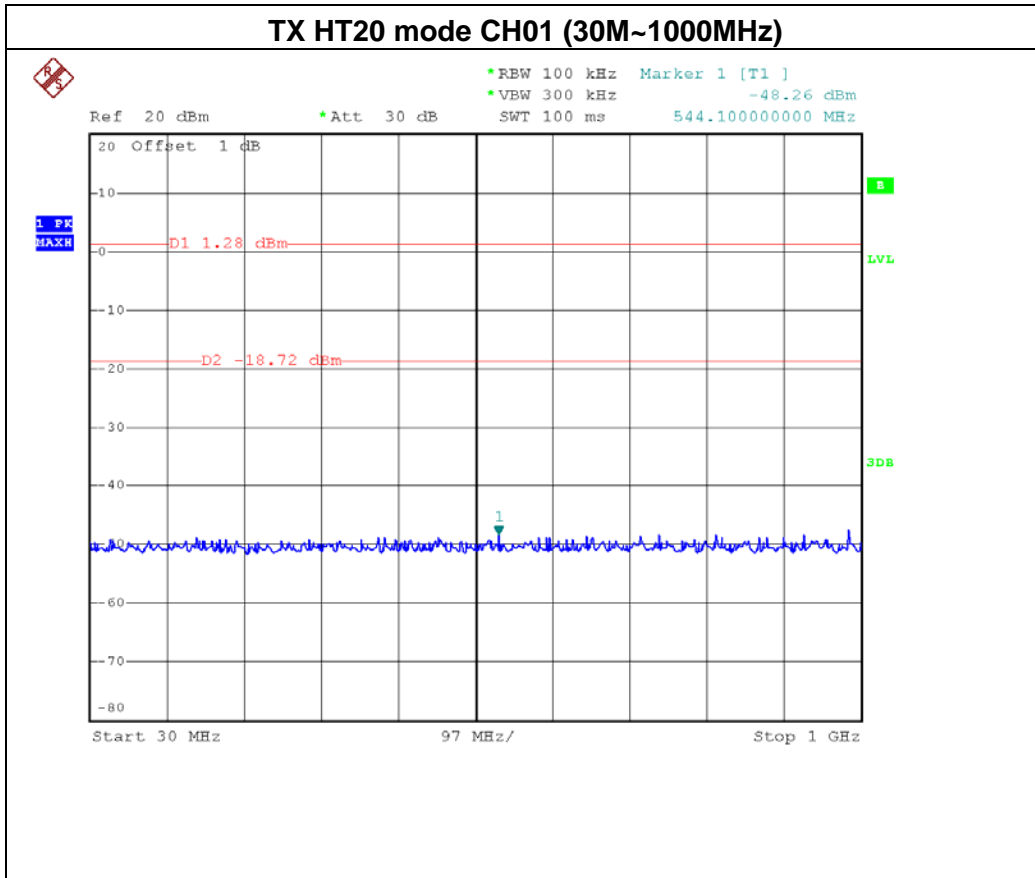

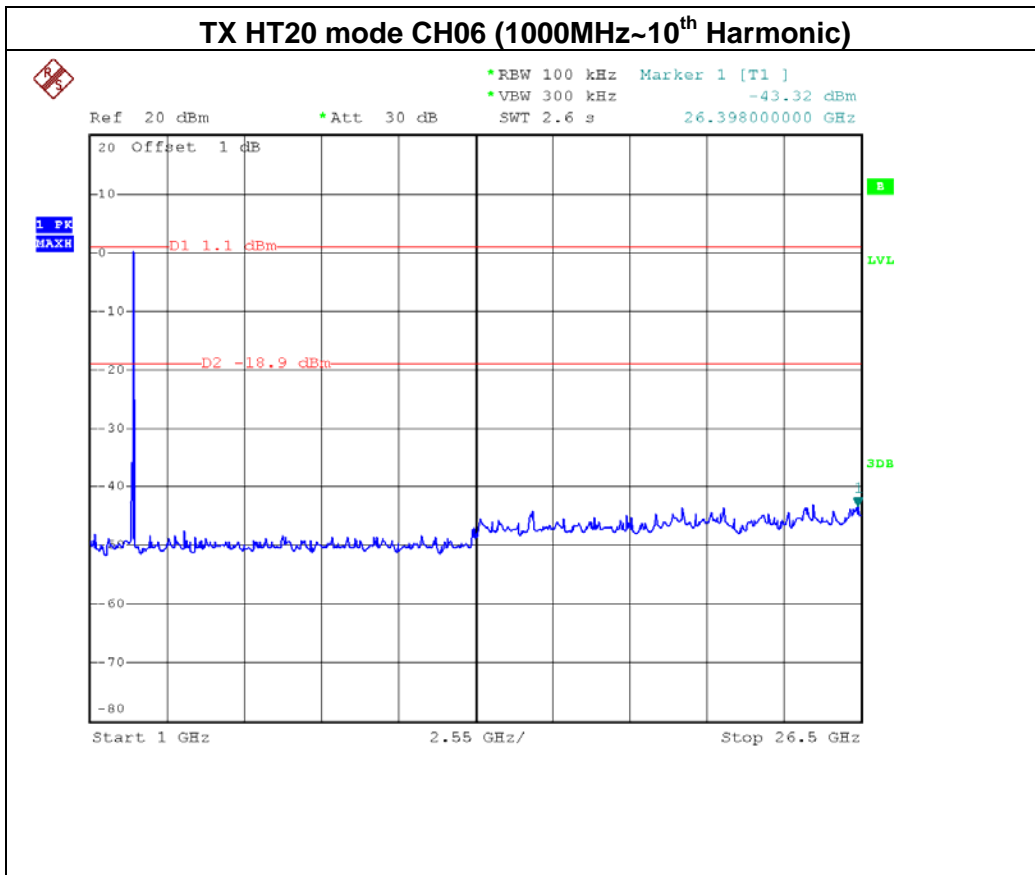
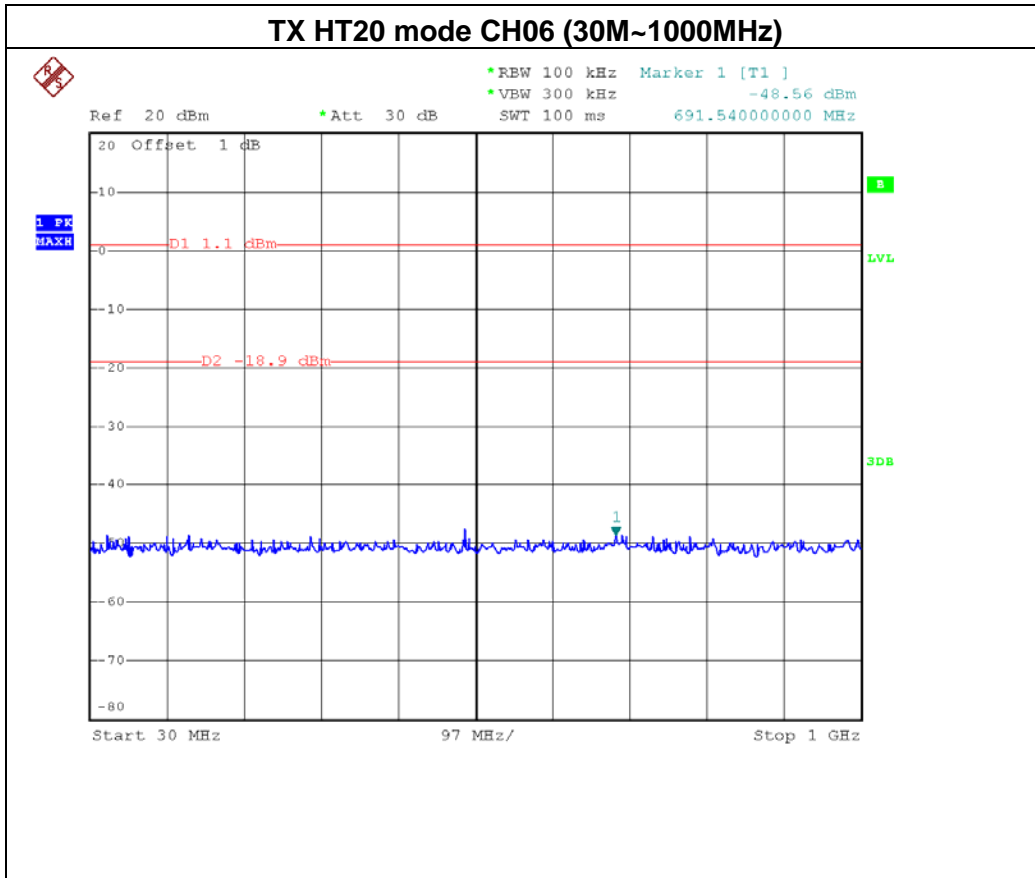

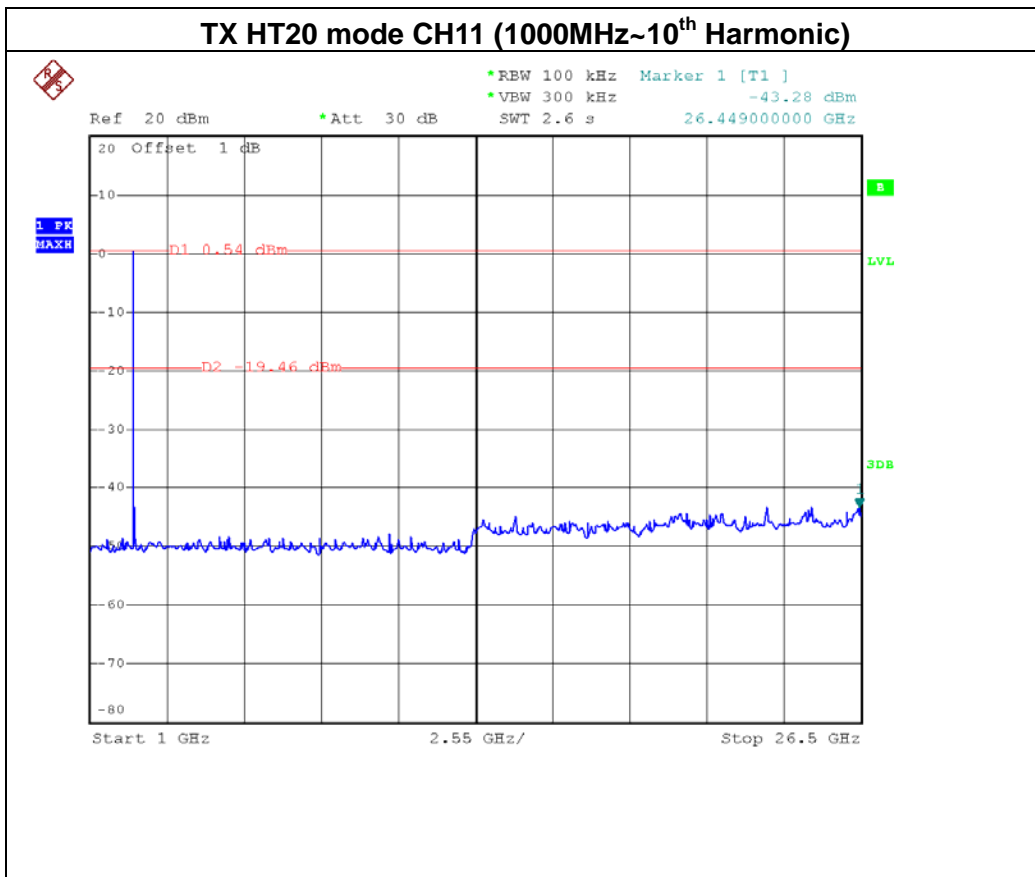
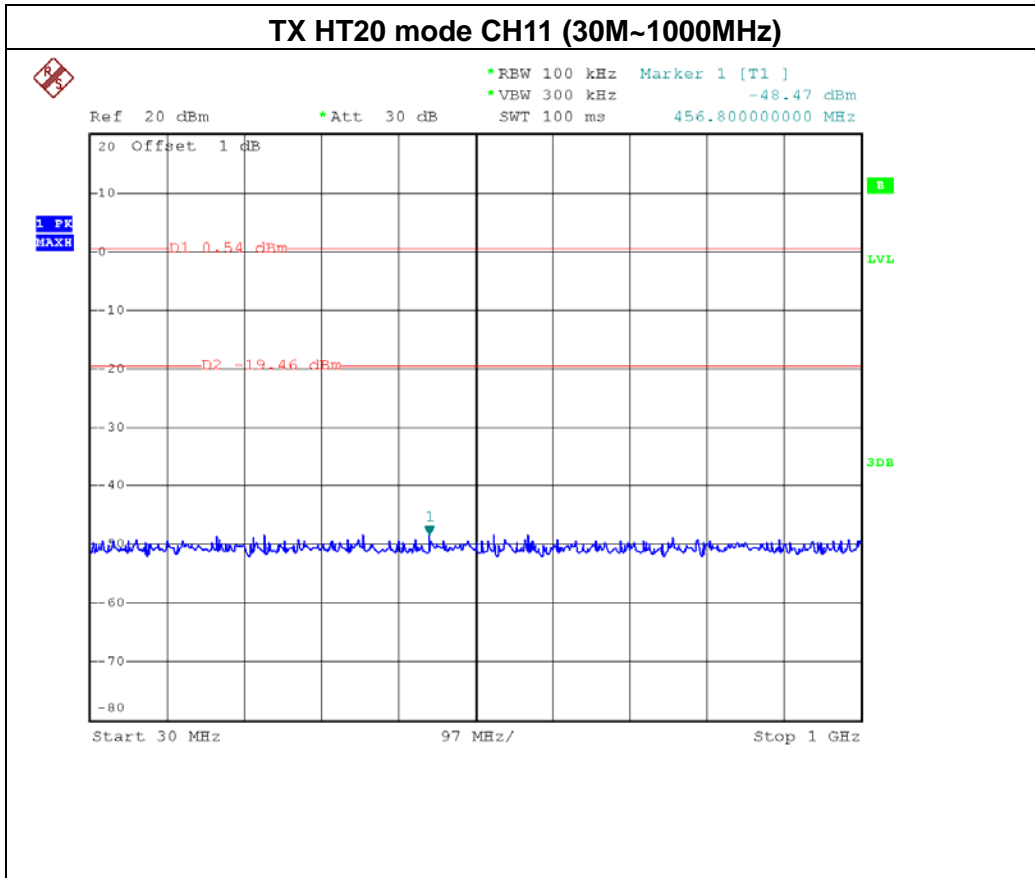



Test Mode :	TX N-20M Mode-ANT 2
-------------	---------------------

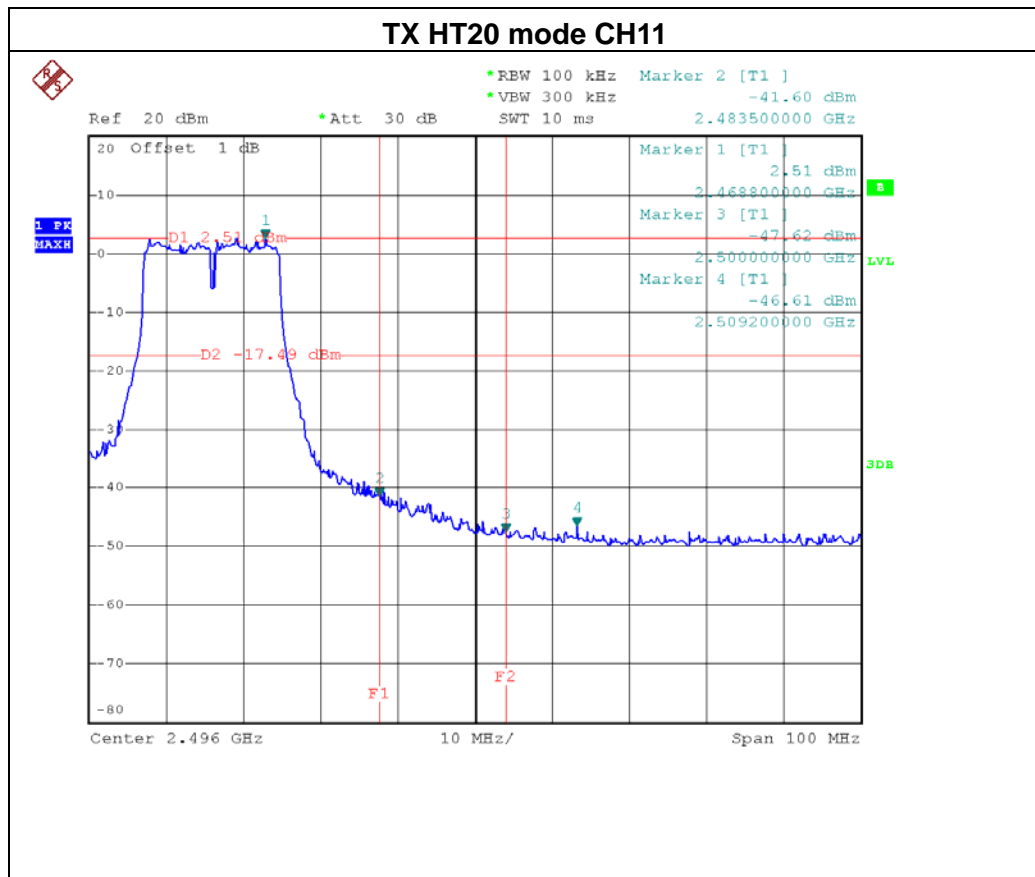
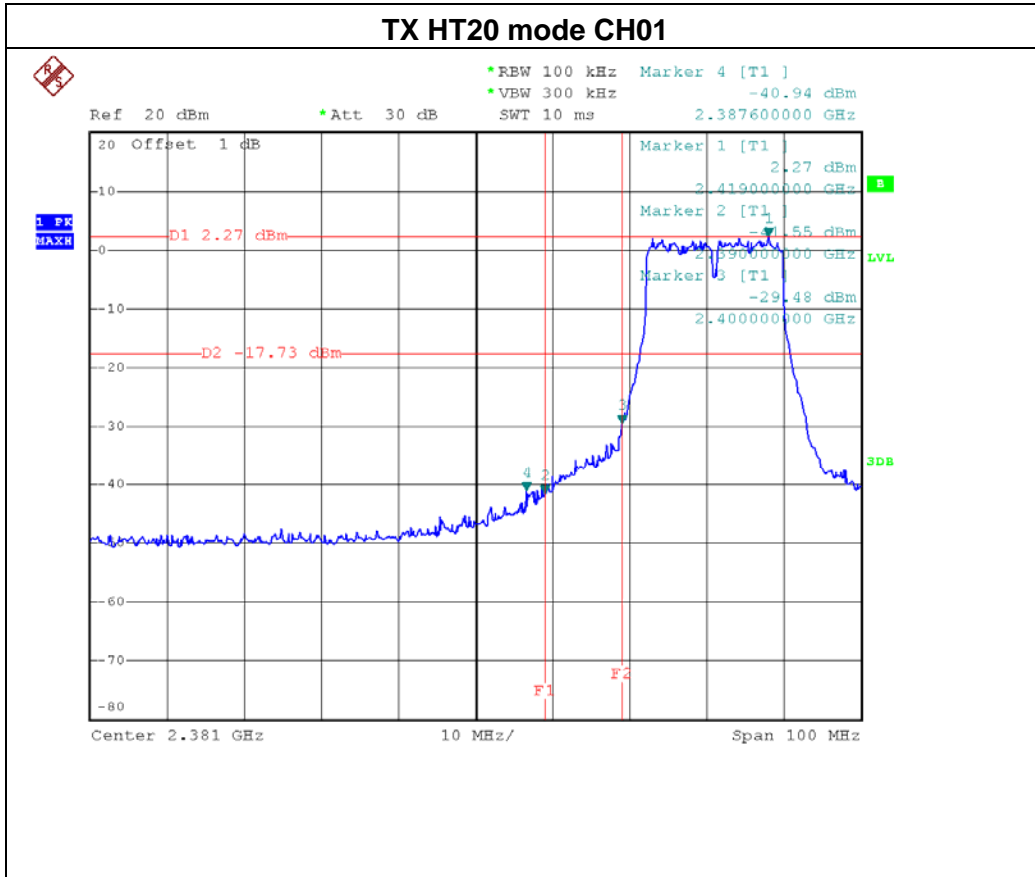

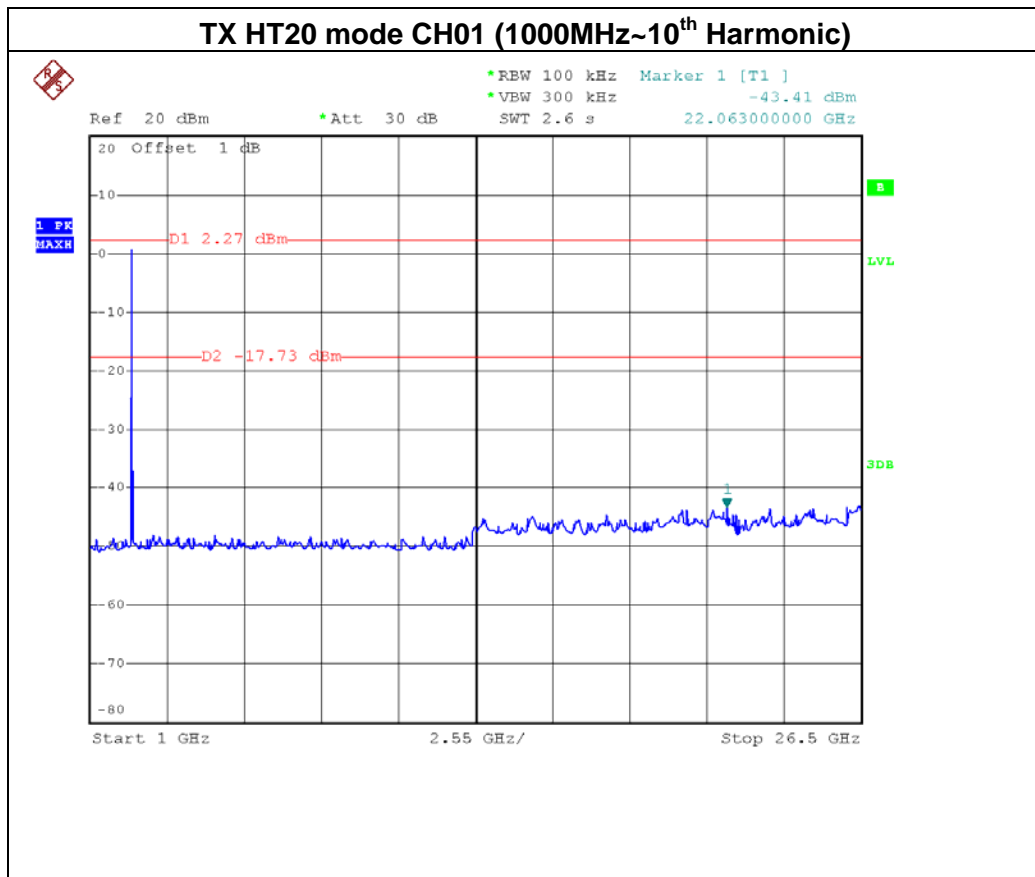
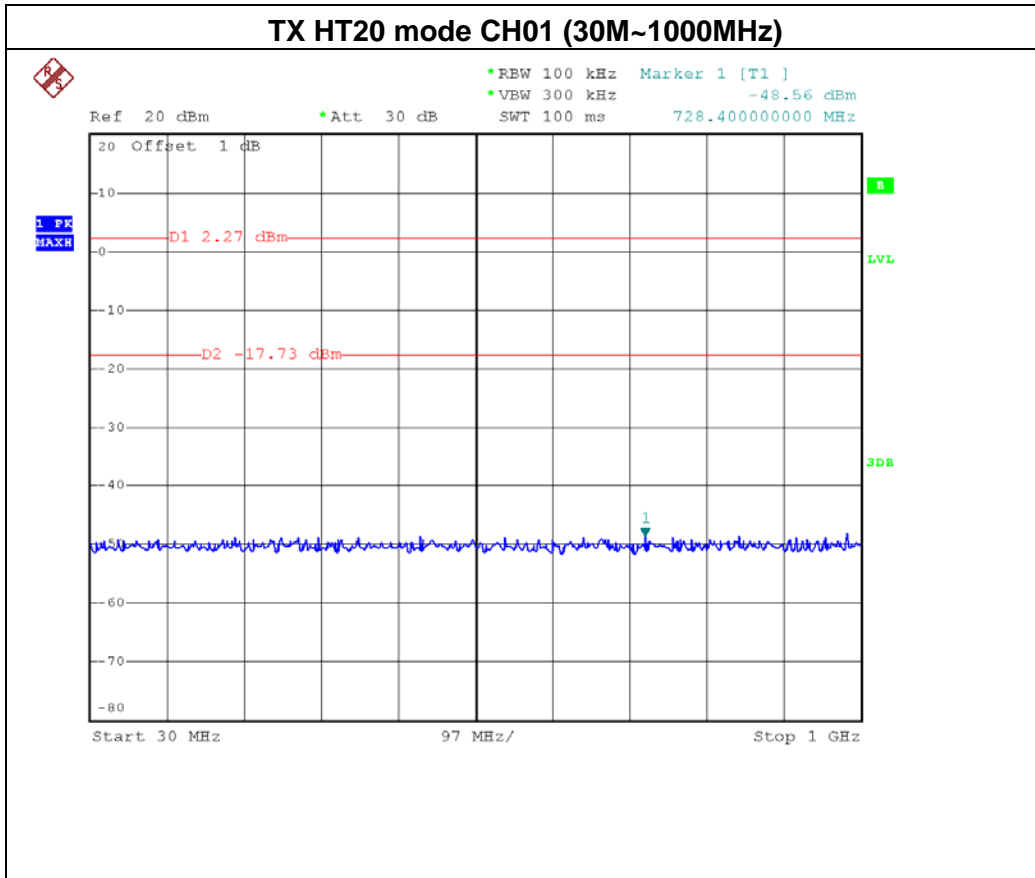

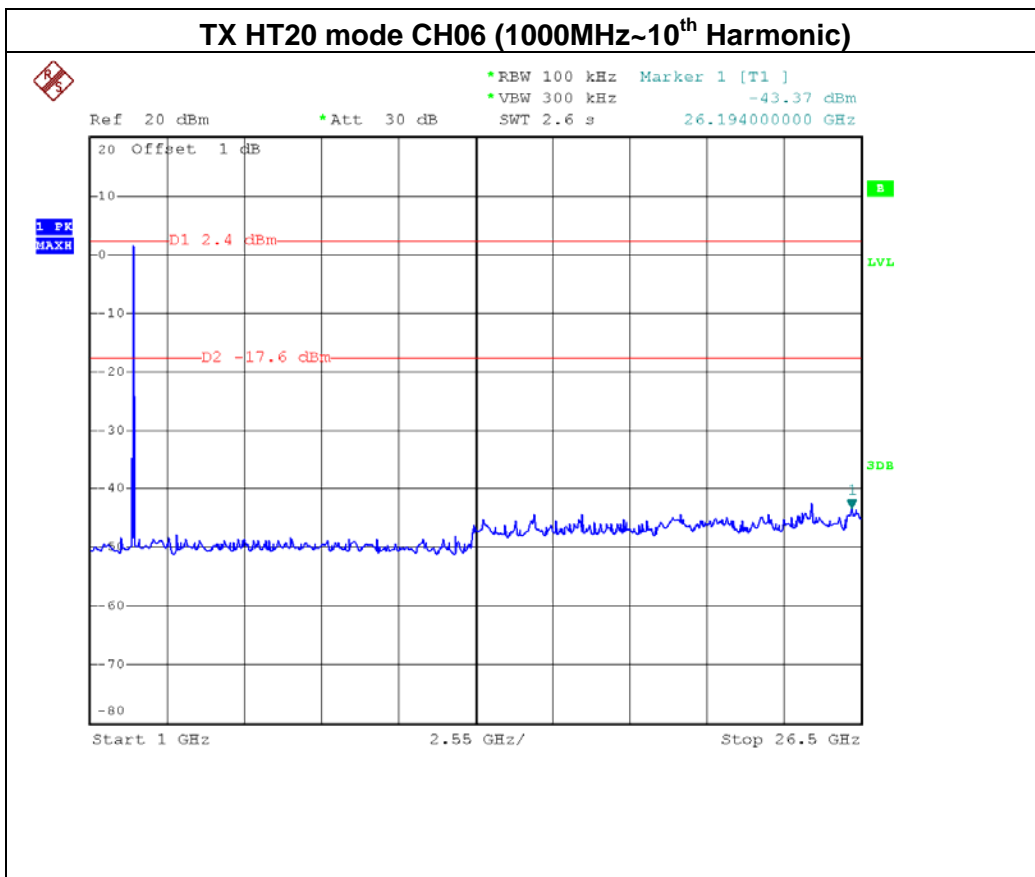
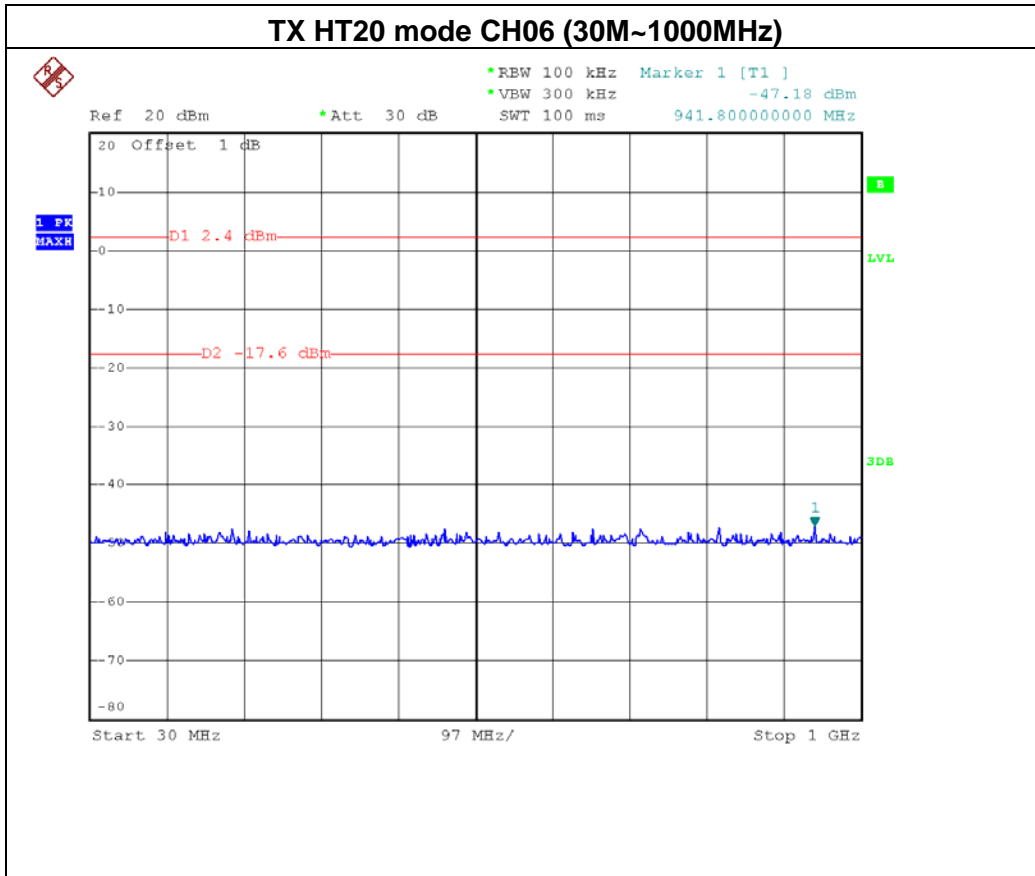

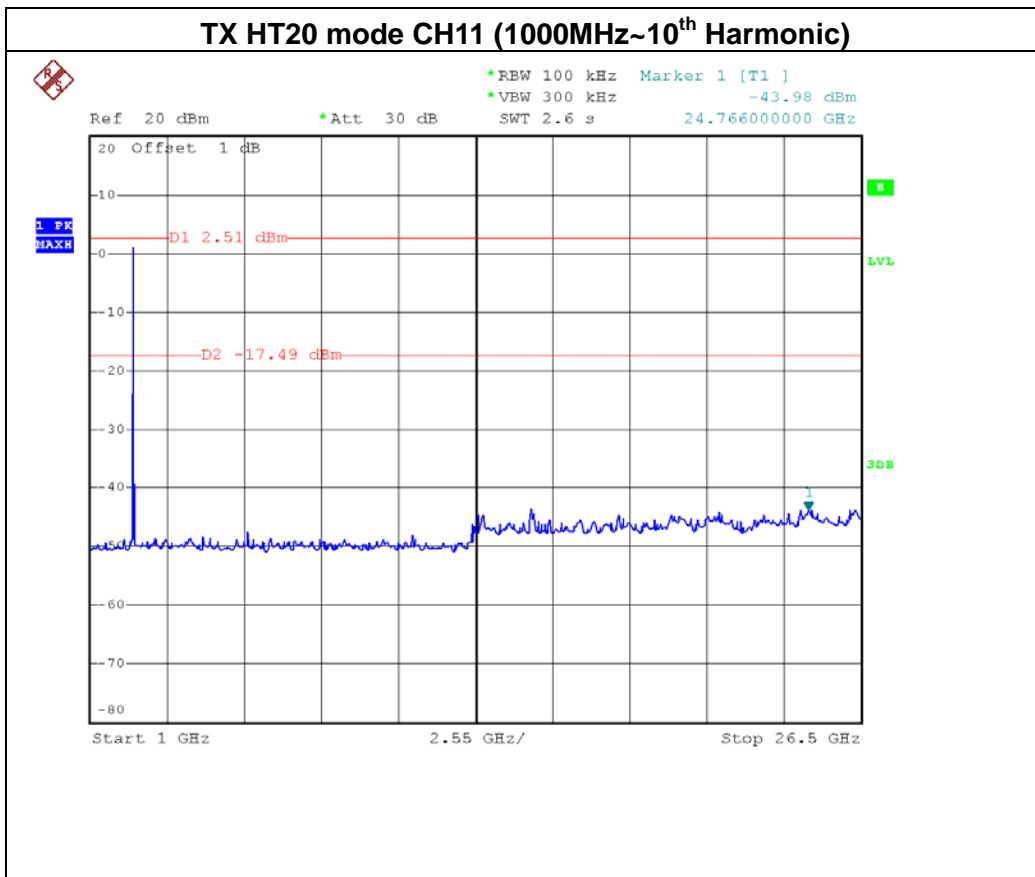
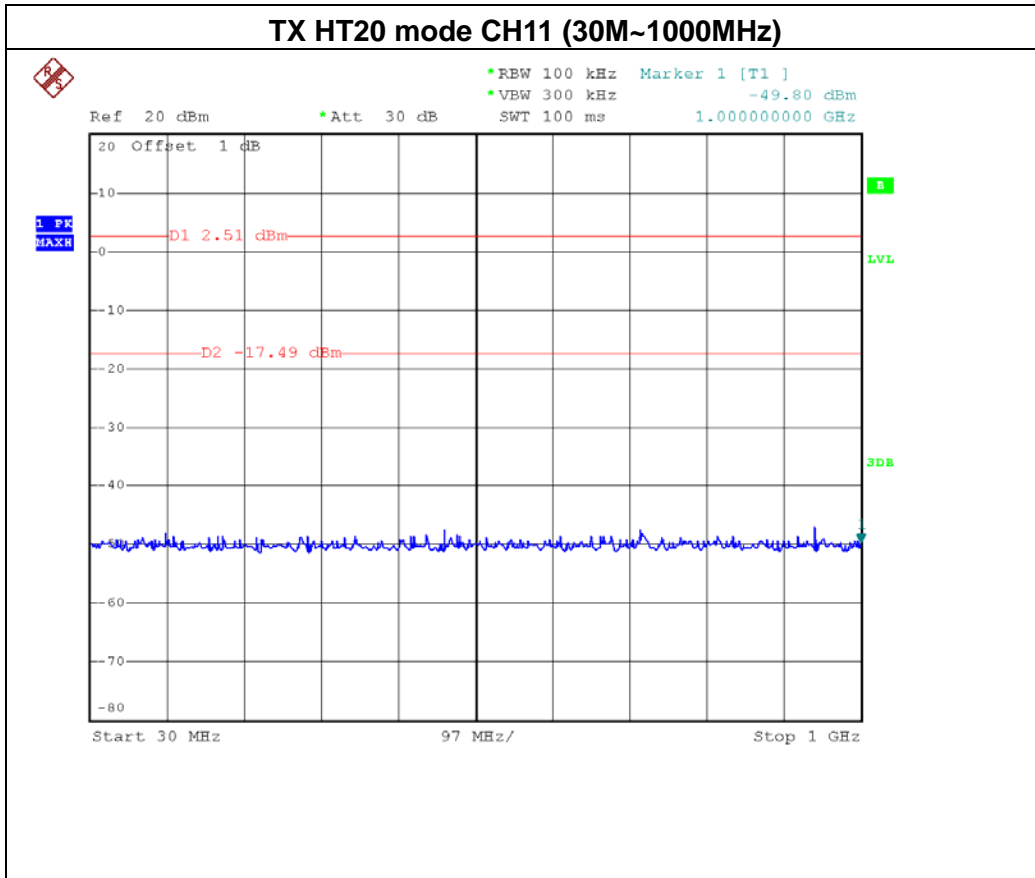



Test Mode :	TX N-40M Mode-ANT 1
-------------	---------------------

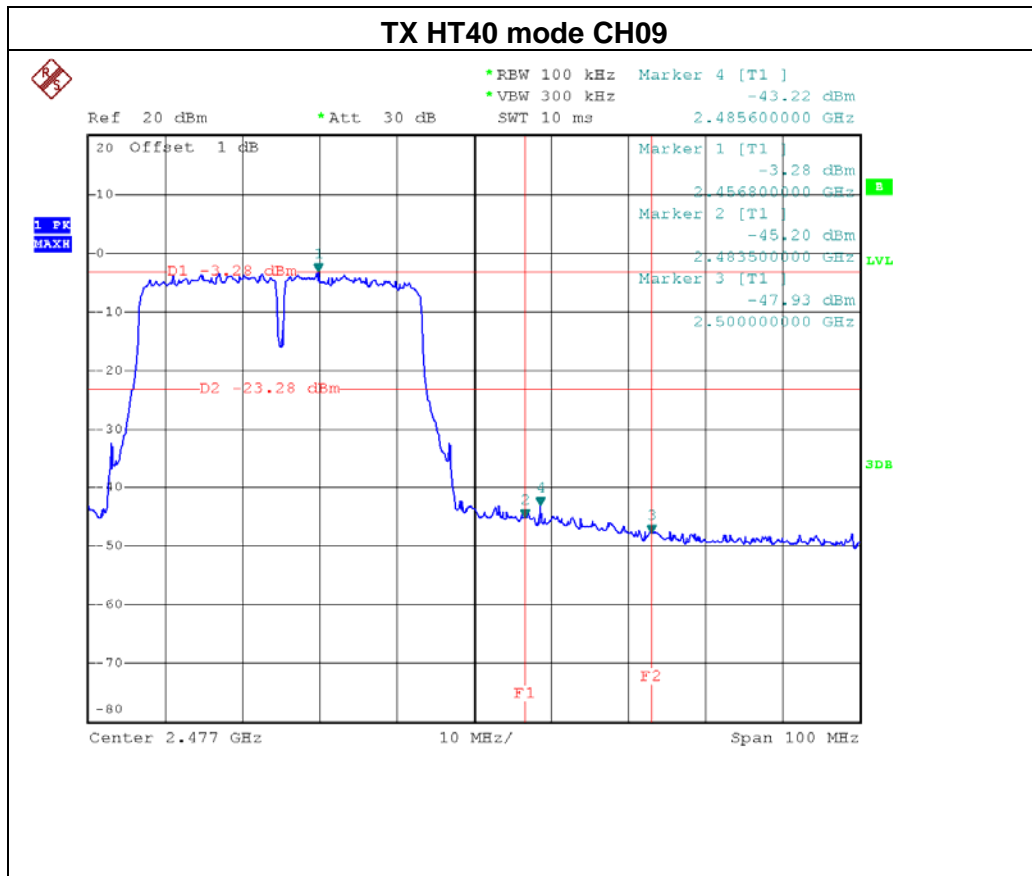
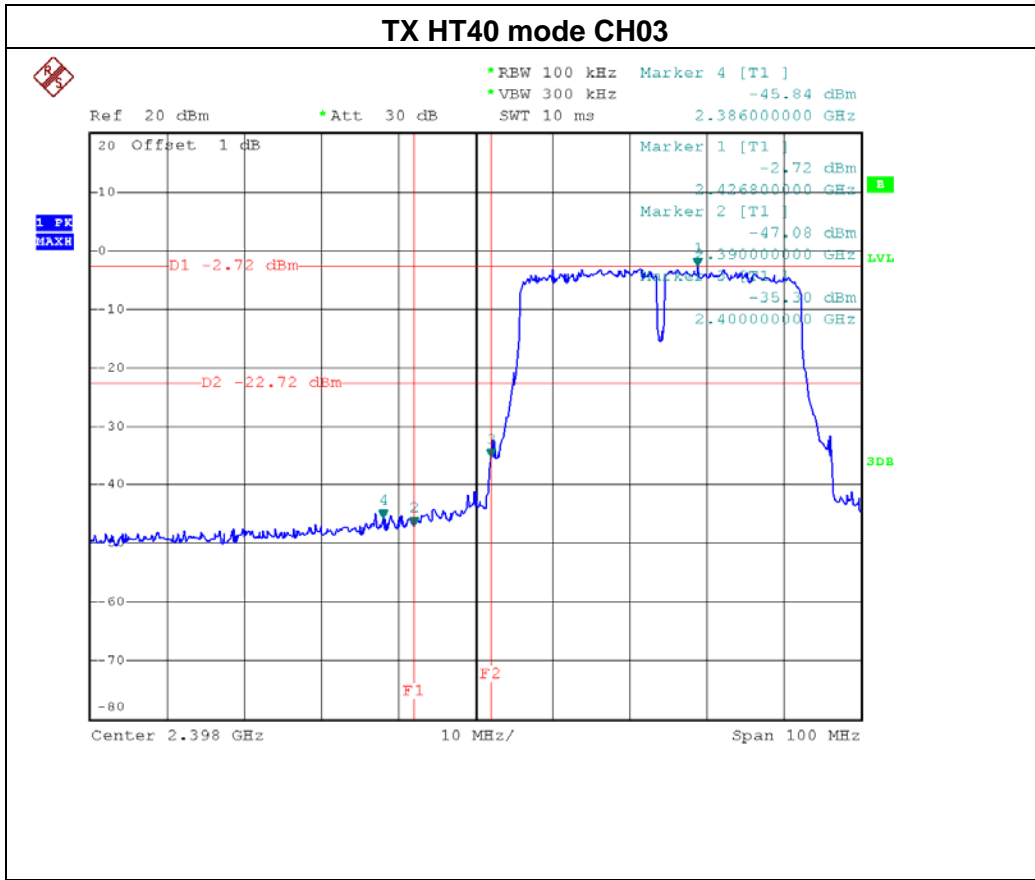

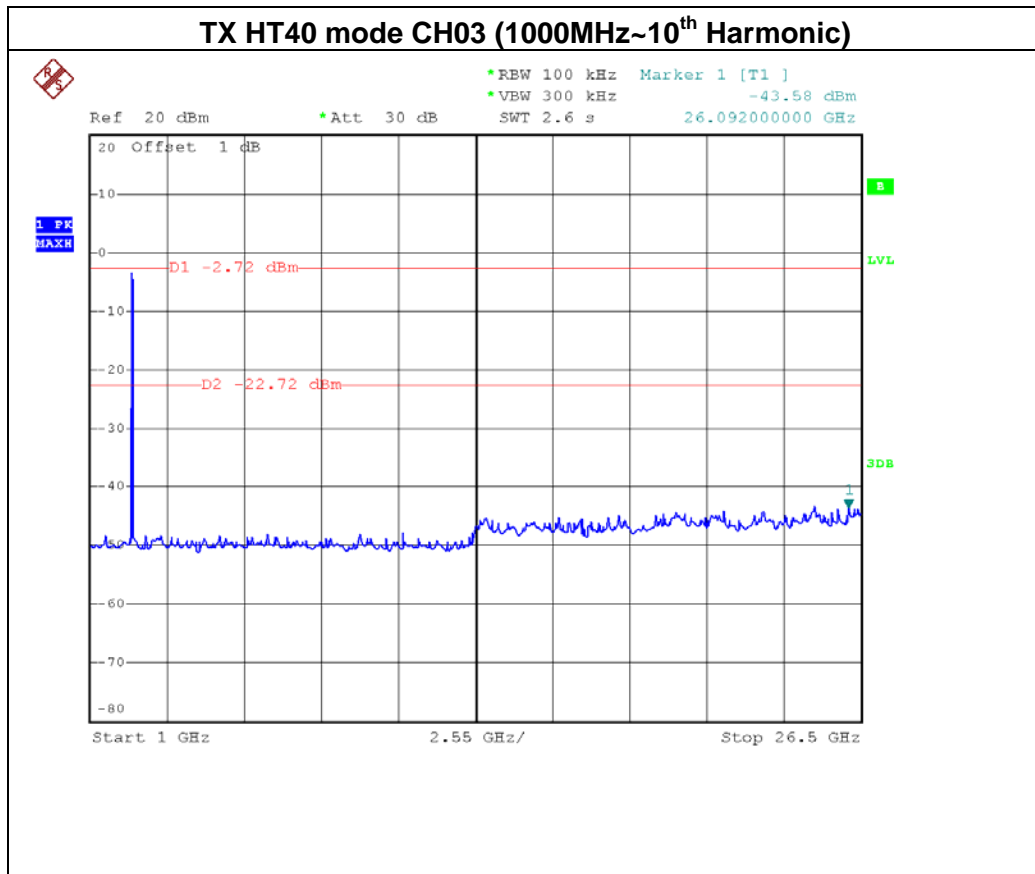
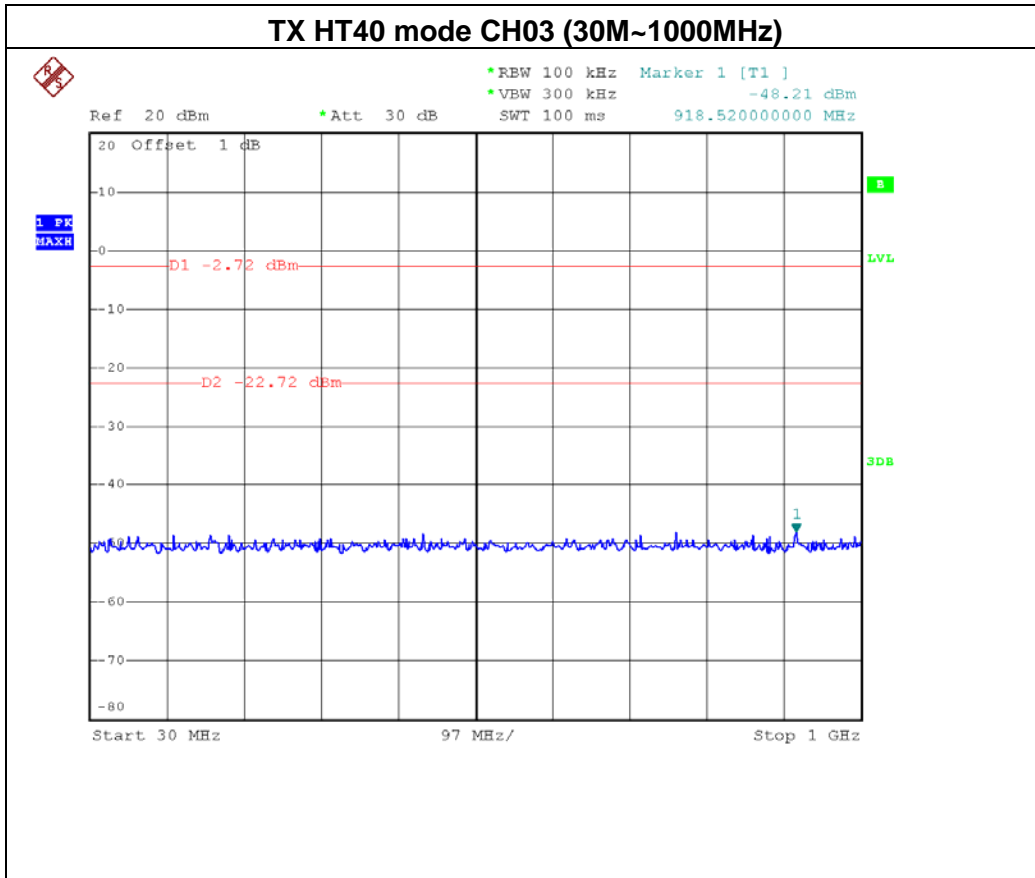

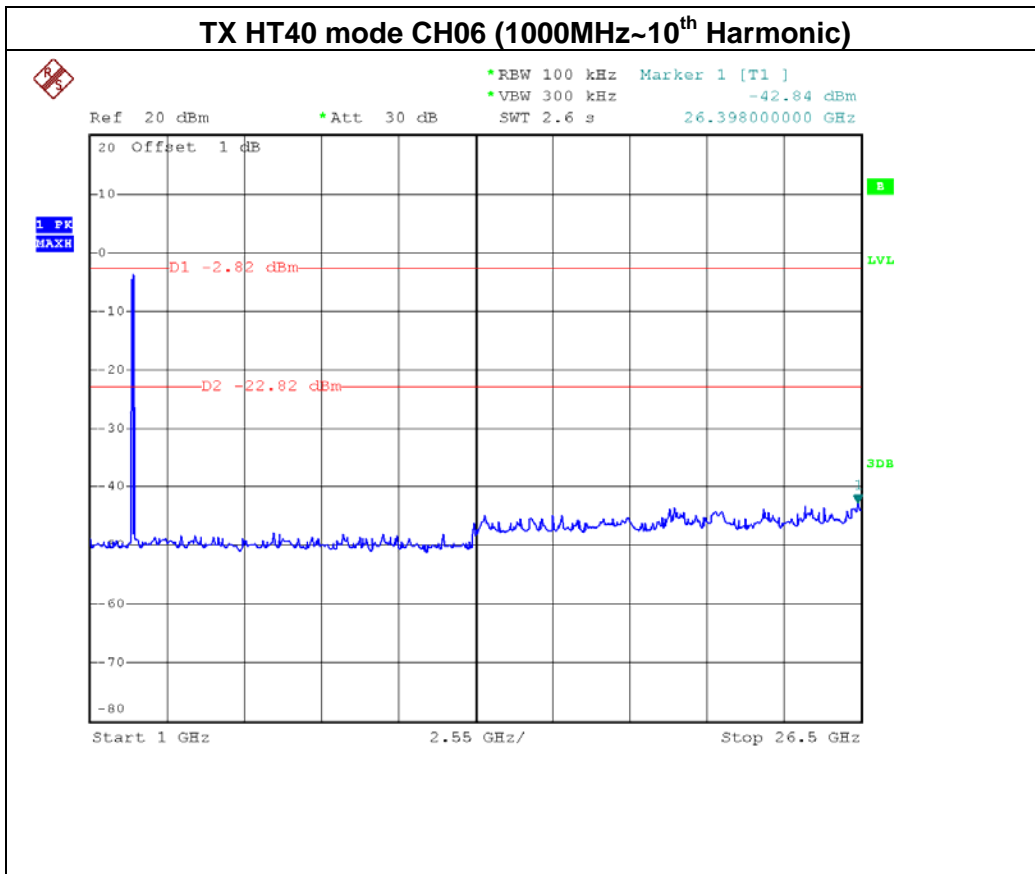
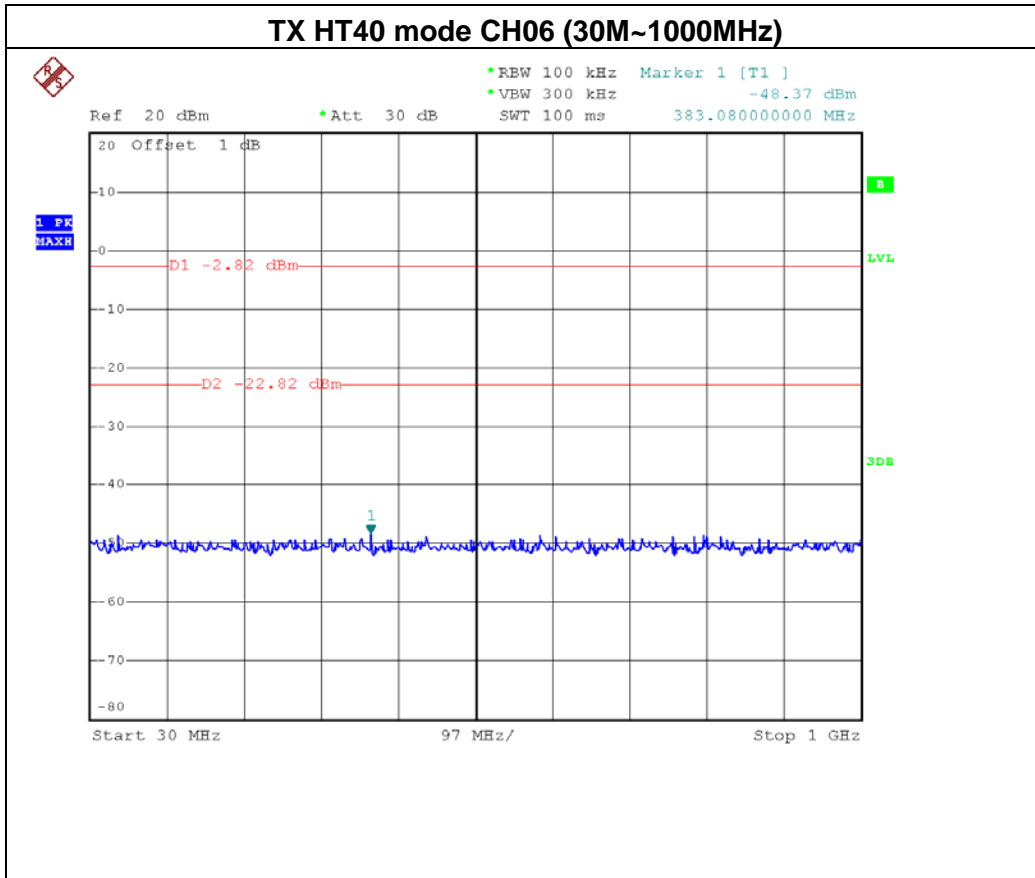

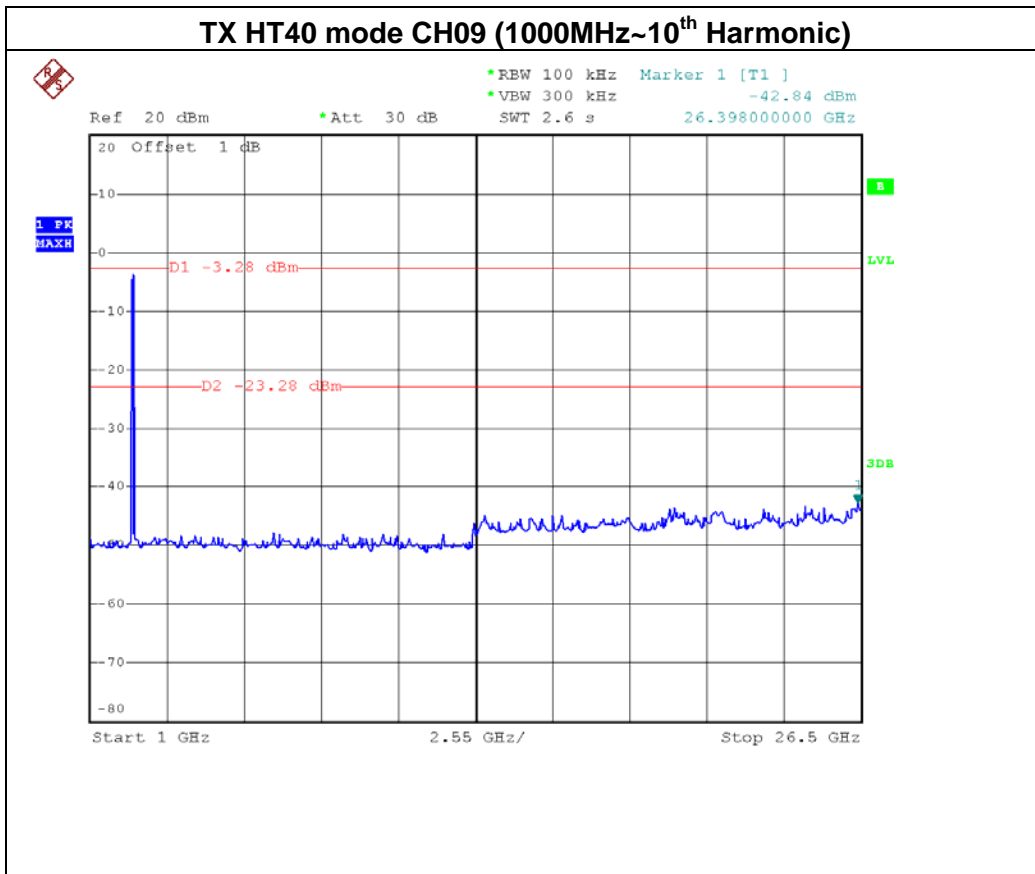
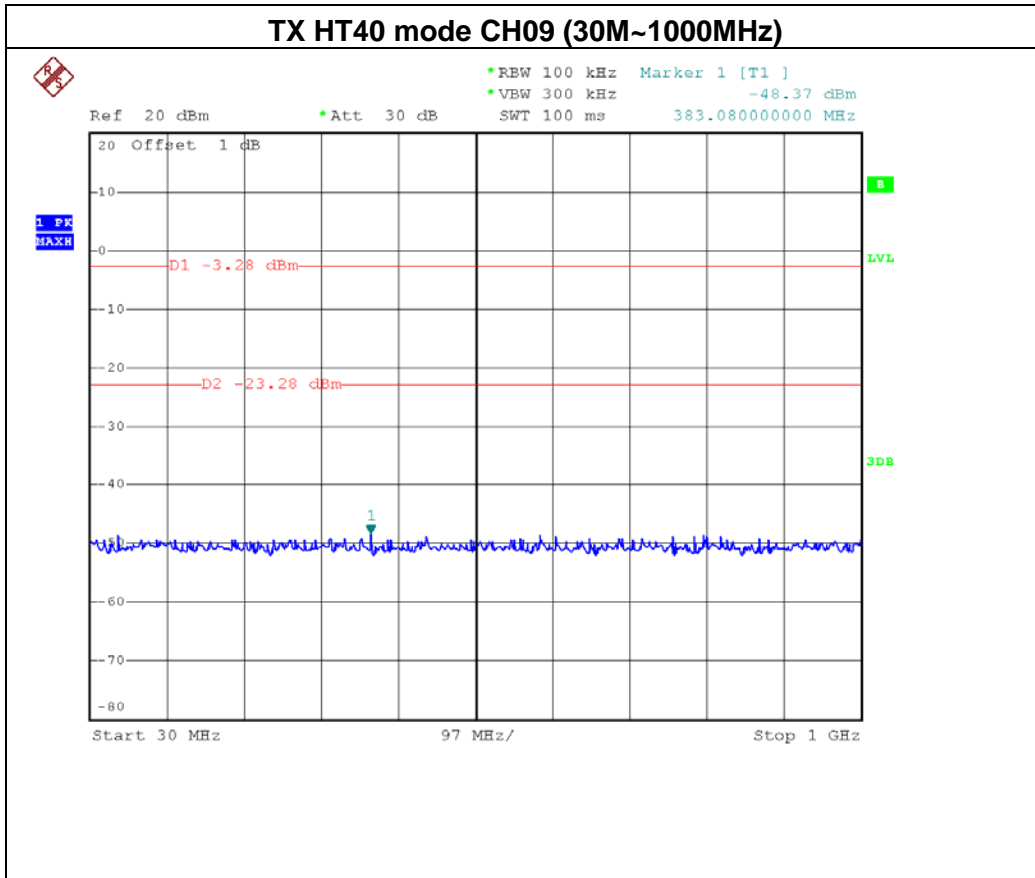



Test Mode :	TX N-40M Mode-ANT 2
-------------	---------------------

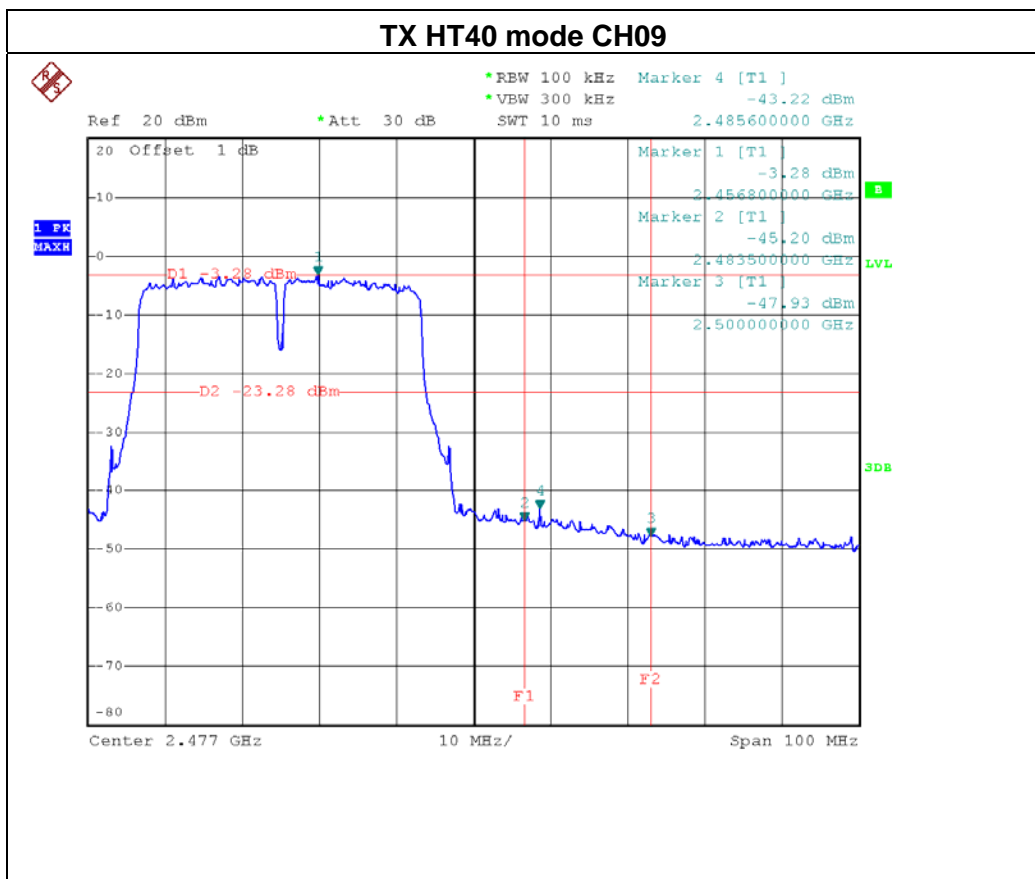
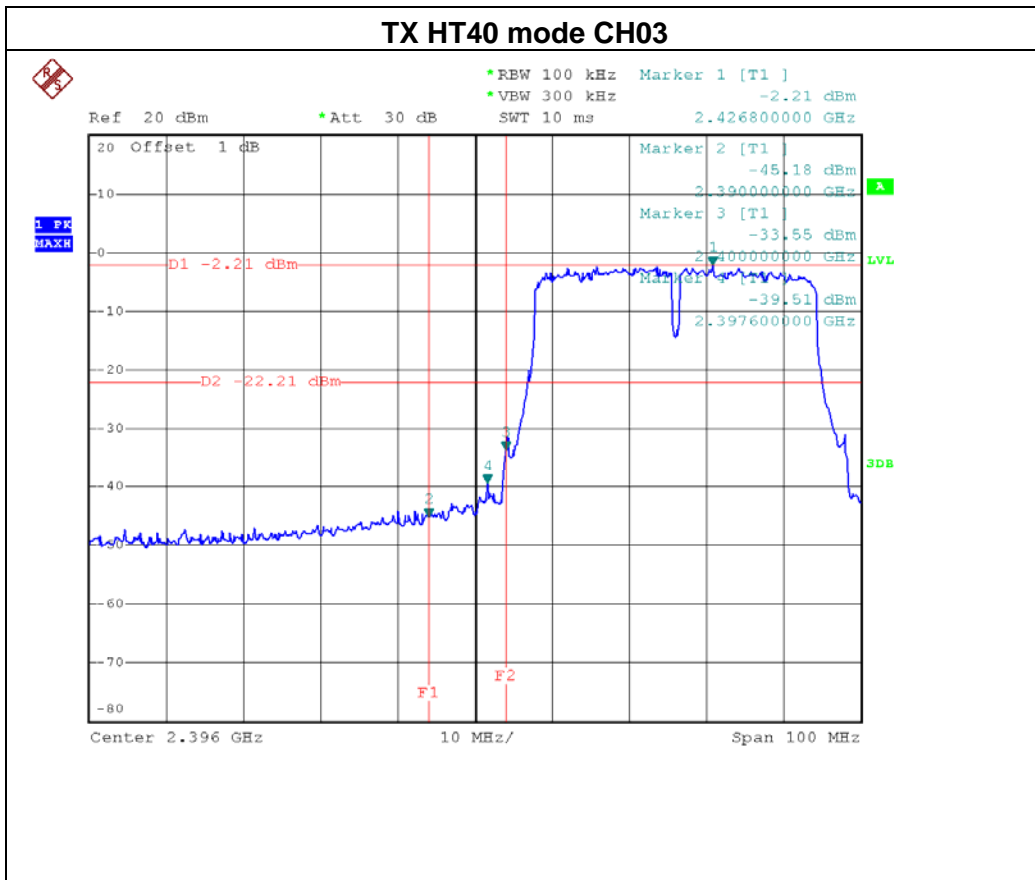

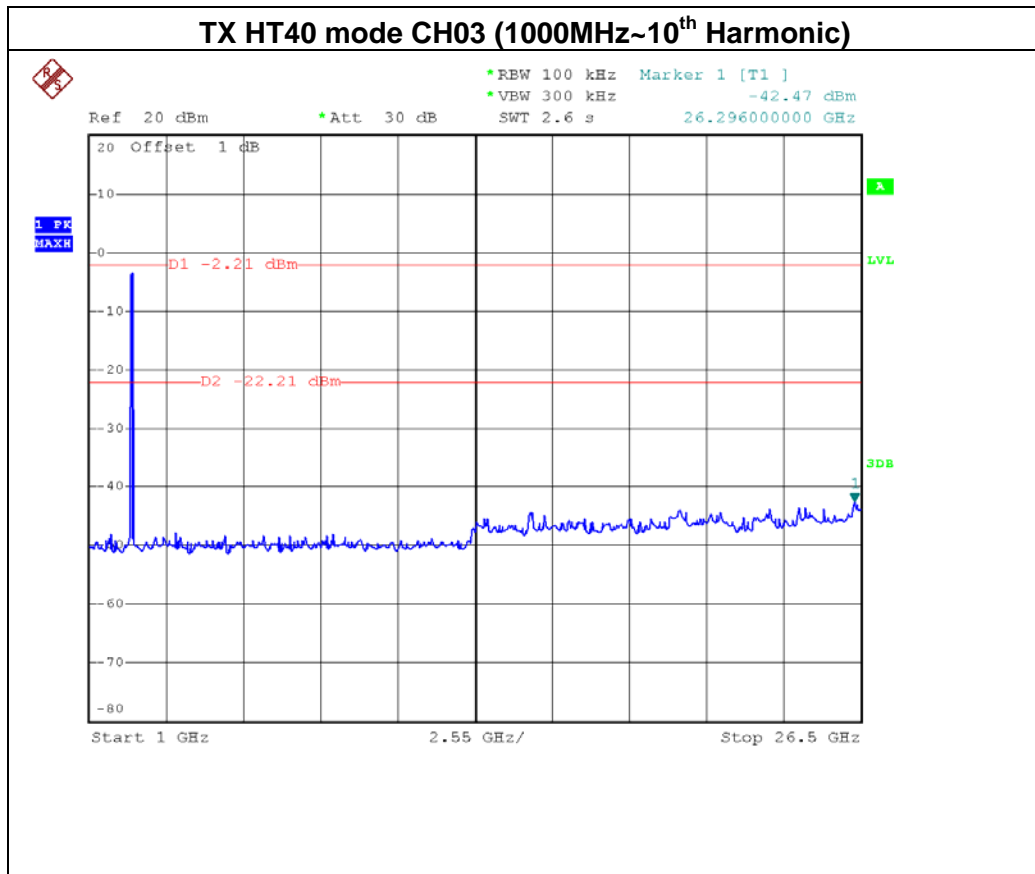
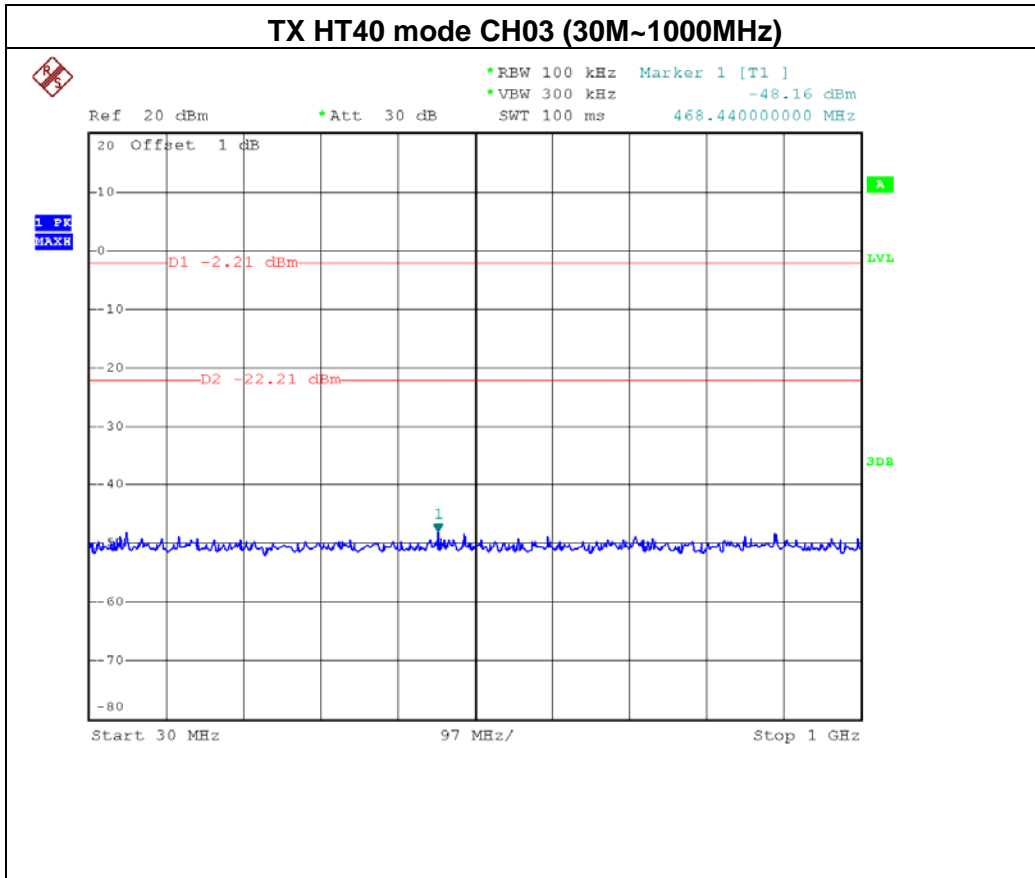

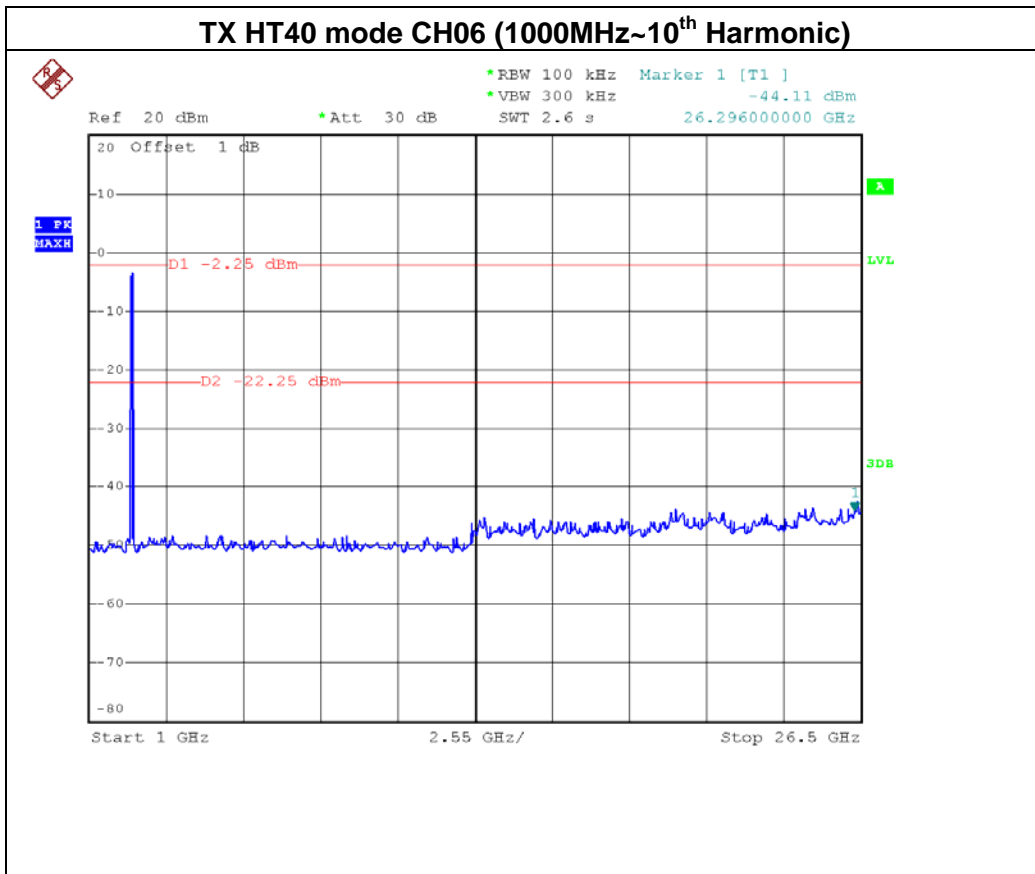
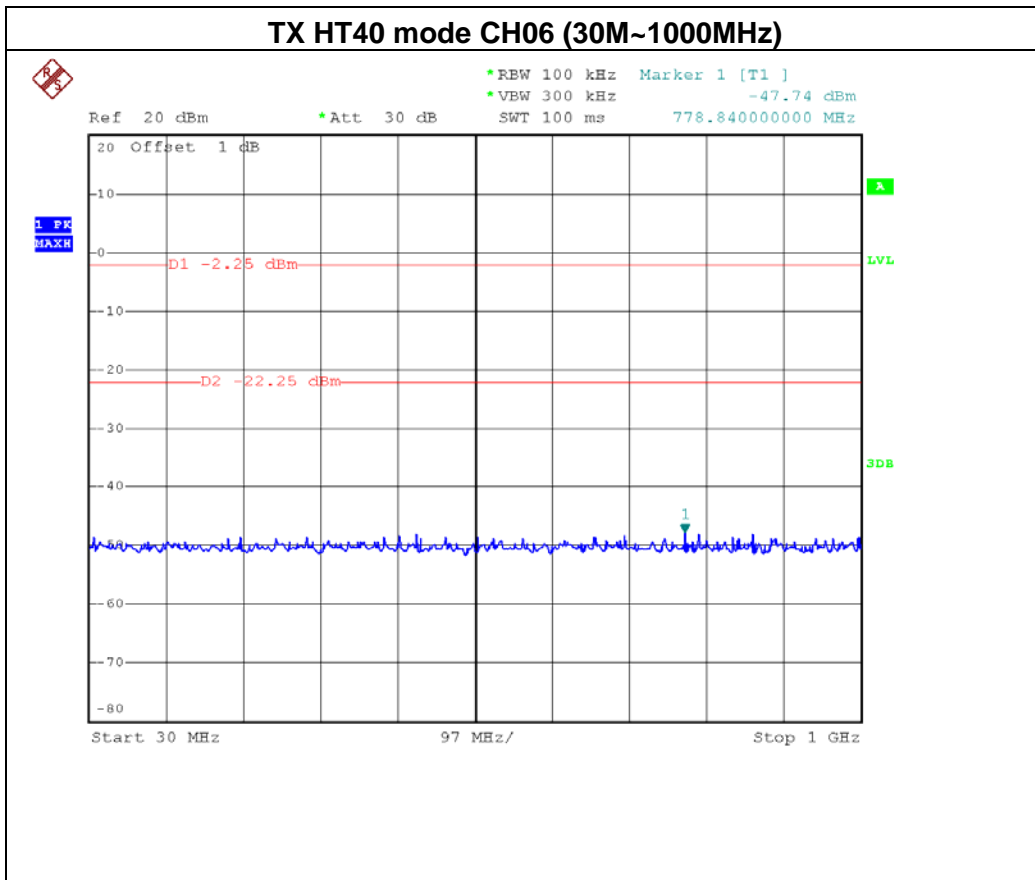

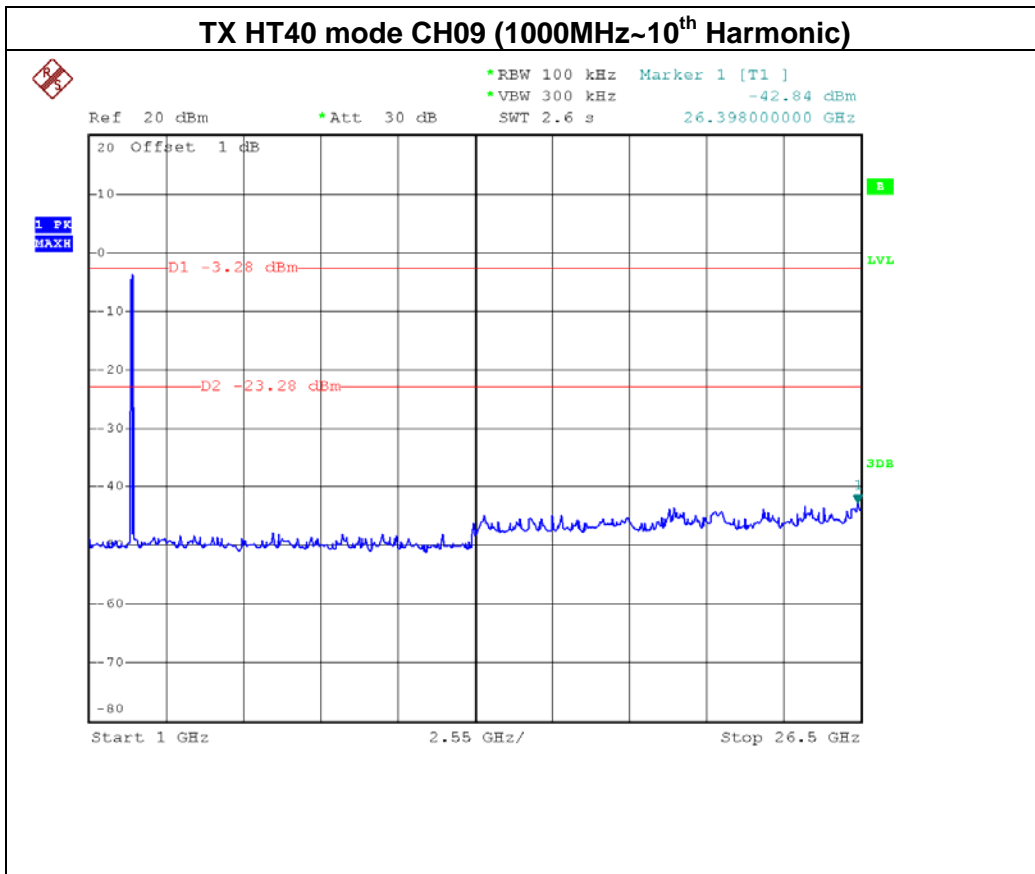
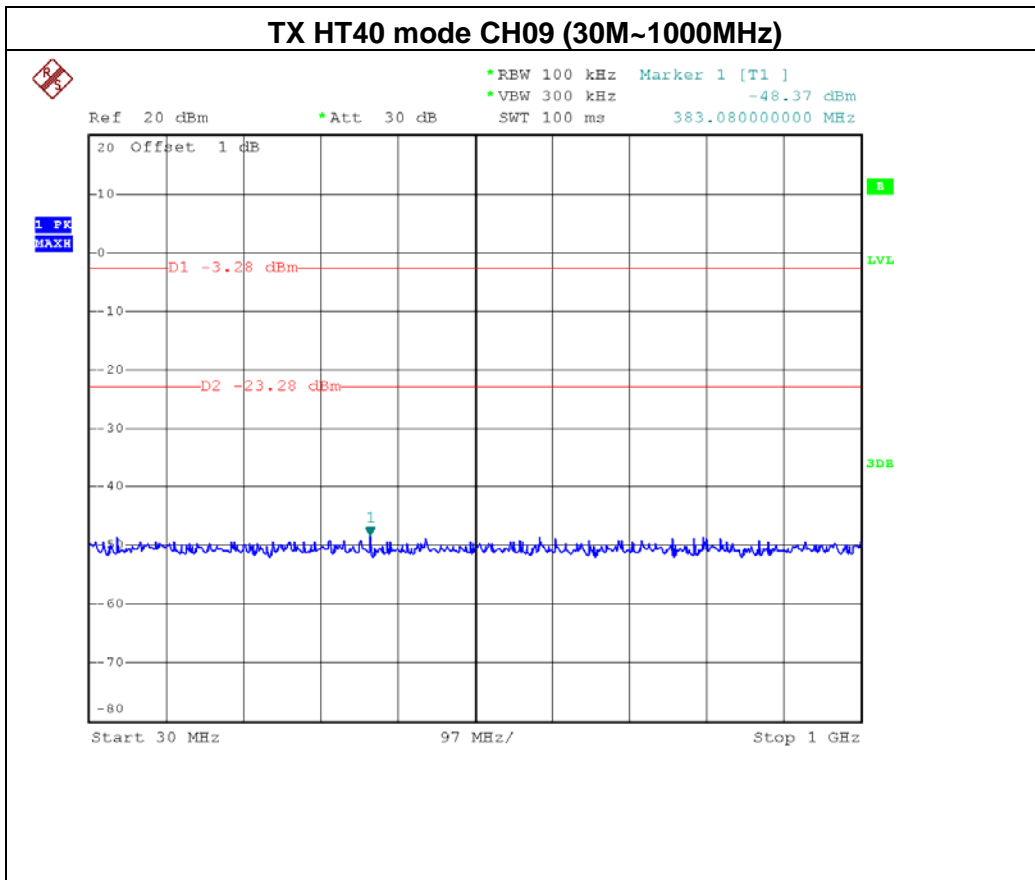



8. POWER SPECTRAL DENSITY TEST

8.1 Applied procedures / limit

FCC Part15 (15.247) , Subpart C / RSS-210				
Section	Test Item	Limit	Frequency Range (MHz)	Result
15.247(e) RSS-210 Annex 8(A8.2(b))	Power Spectral Density	8 dBm (in any 3KHz)	2400-2483.5	PASS

8.1.1 TEST PROCEDURE

- a. The EUT was directly connected to the spectrum analyzer and antenna output port as show in the block diagram below,
- b. Spectrum Setting: RBW=3KHz, VBW=10KHz, Sweep time = Auto.

8.1.2 DEVIATION FROM STANDARD

No deviation.

8.1.3 TEST SETUP



8.1.4 EUT OPERATION CONDITIONS

The EUT tested system was configured as the statements of 4.1.6 Unless otherwise a special operating condition is specified in the follows during the testing.

8.1.5 EUT TEST CONDITIONS

Temperature: 25°C
 Relative Humidity: 55%
 Test Voltage: 120V/60Hz



8.1.6 TEST RESULTS

Test Mode :TX B Mode			
Test Channel	Frequency (MHz)	Power Density (dBm)	Limit (dBm)
CH01	2412	-15.02	8
CH06	2437	-15.07	8
CH11	2462	-15.19	8

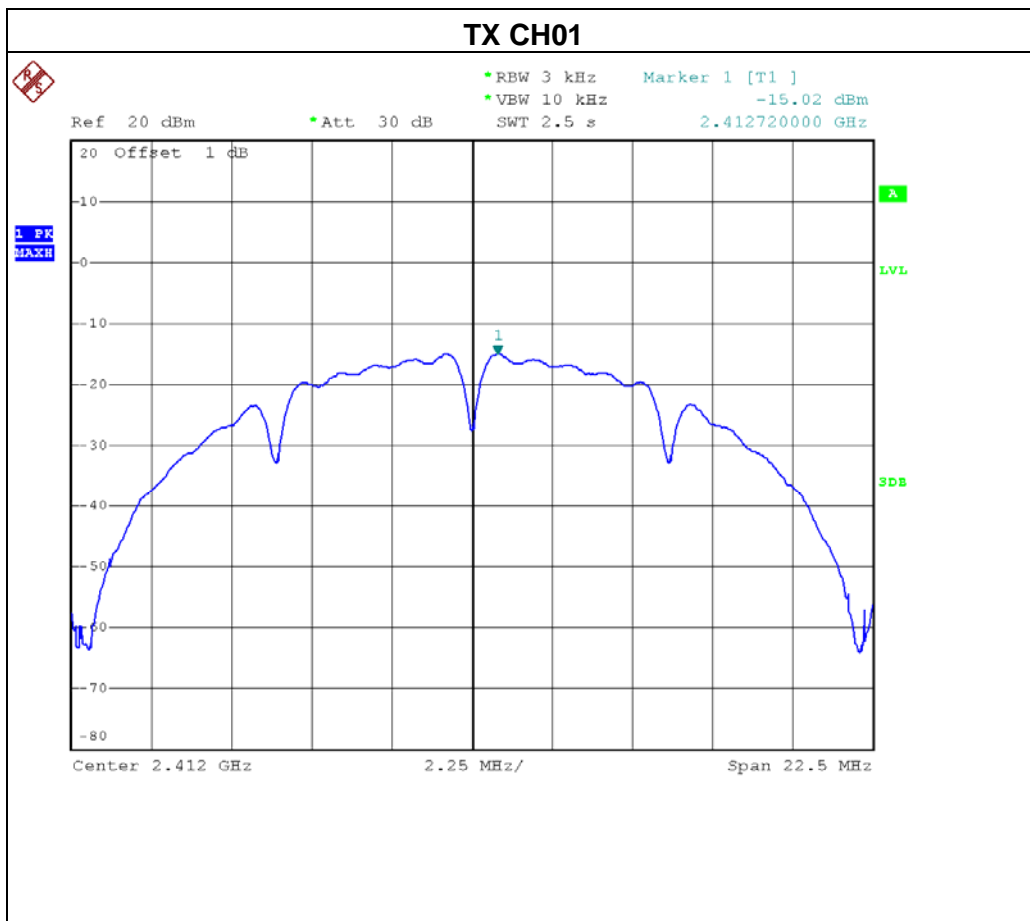

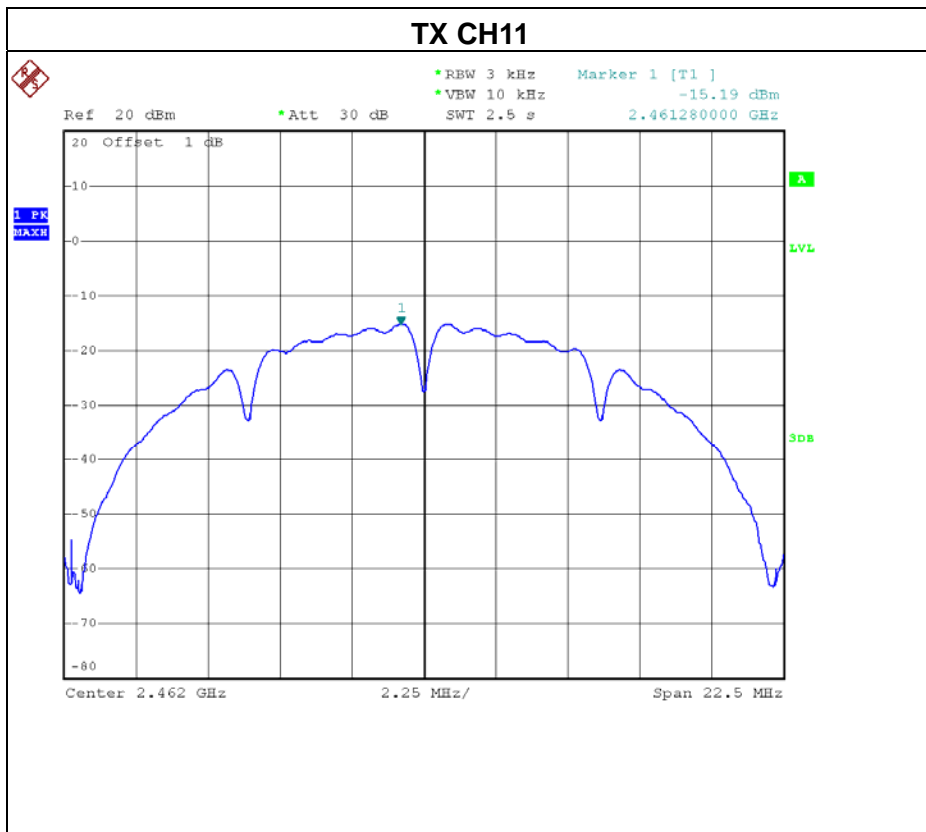
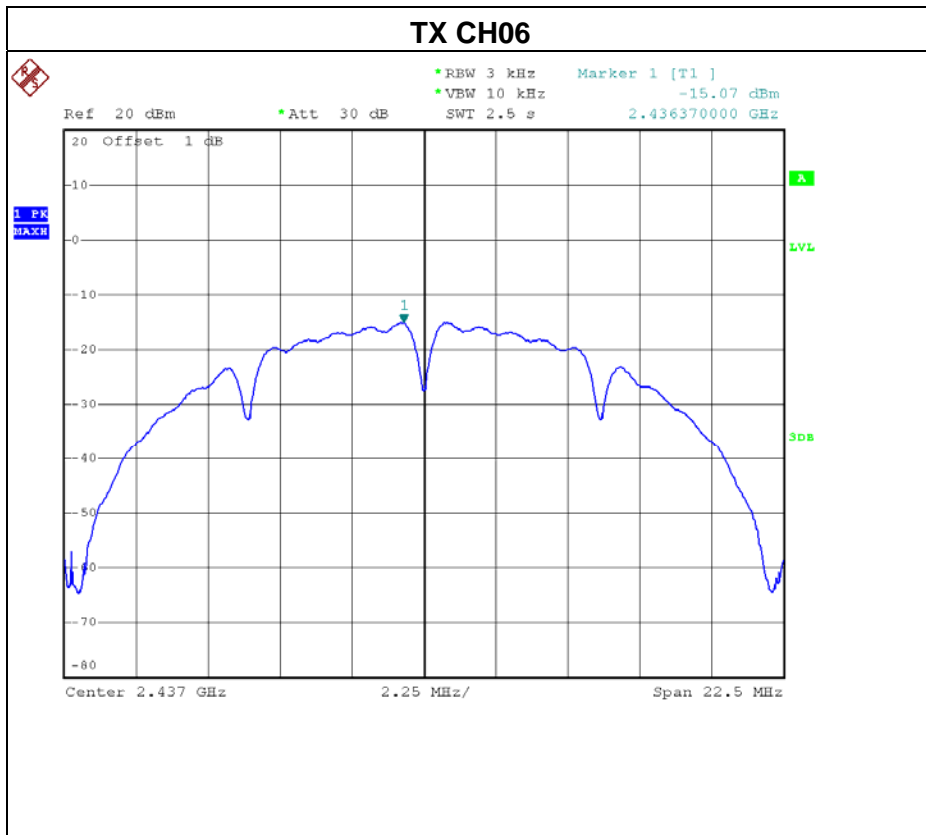

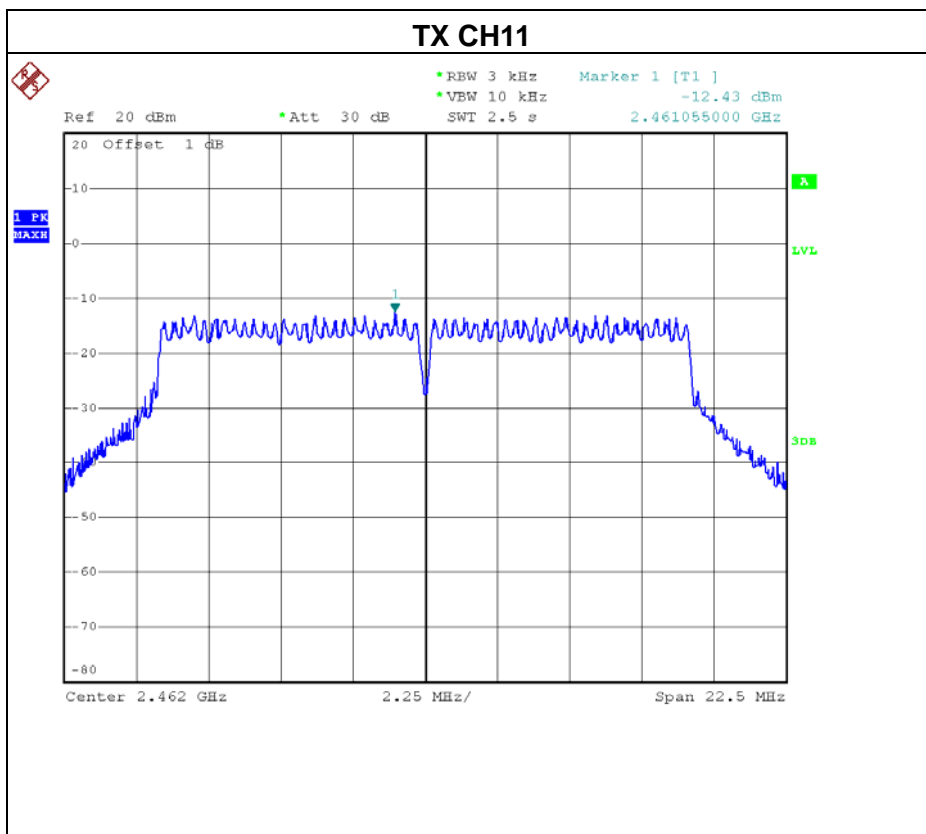
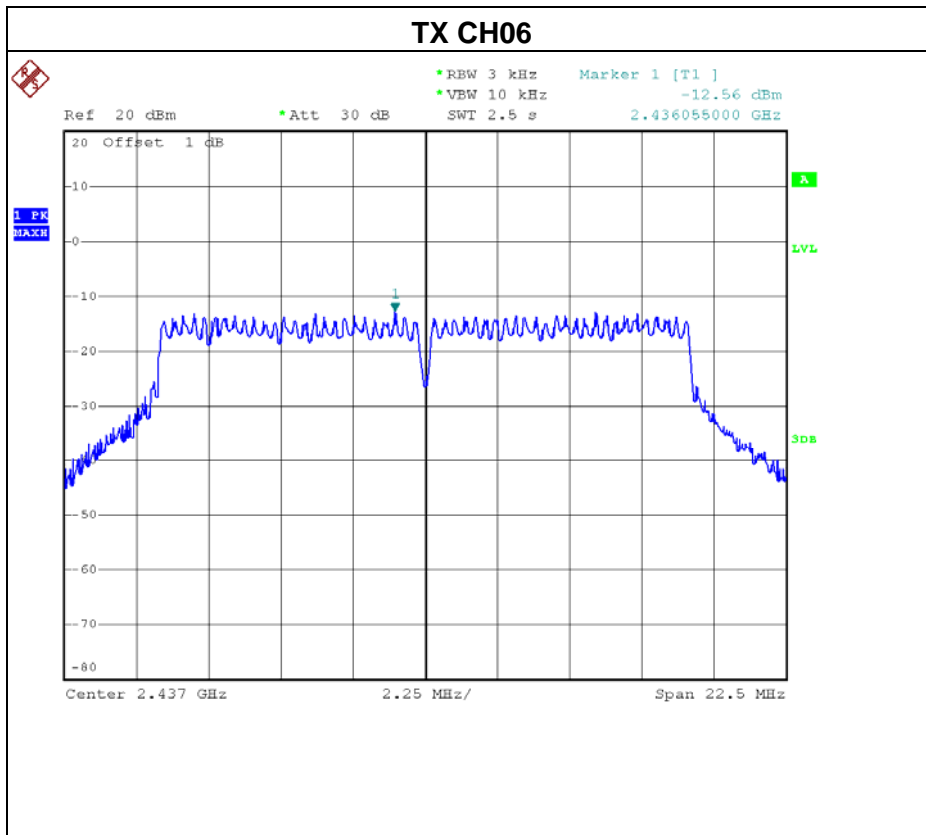



Test Mode : TX N-20M Mode-ANT 1			
Test Channel	Frequency (MHz)	Power Density (dBm)	Limit (dBm)
CH01	2412	-11.08	8
CH06	2437	-12.29	8
CH11	2462	-11.79	8

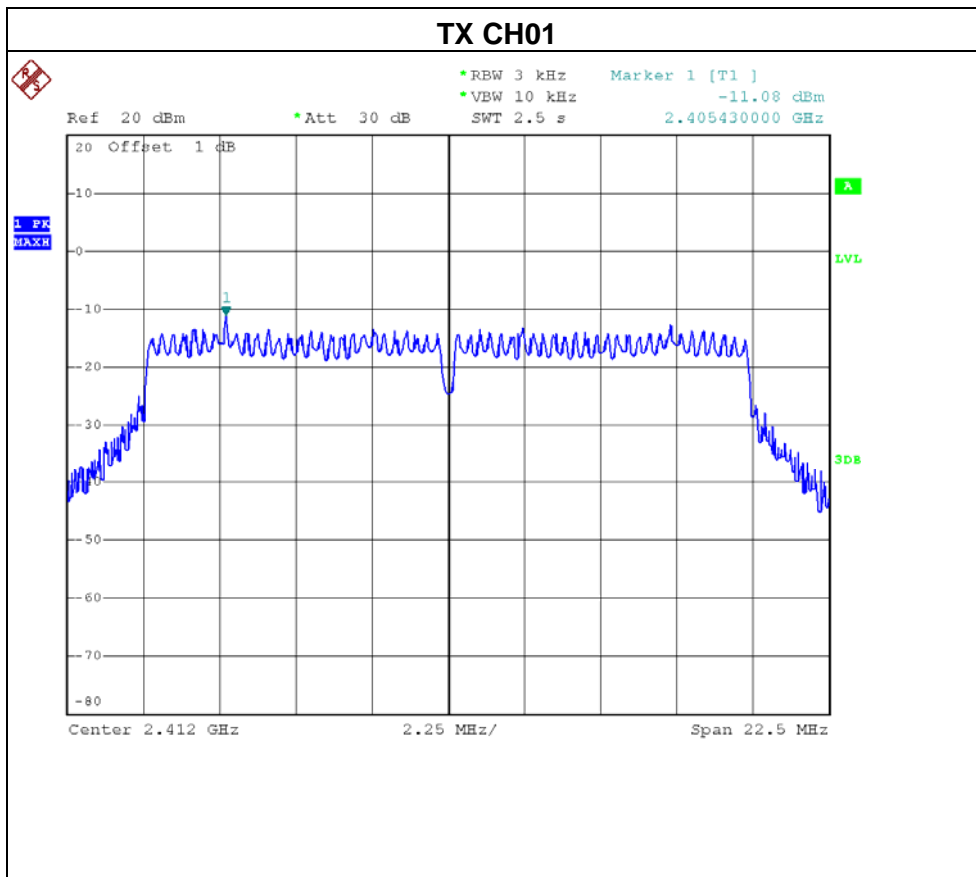

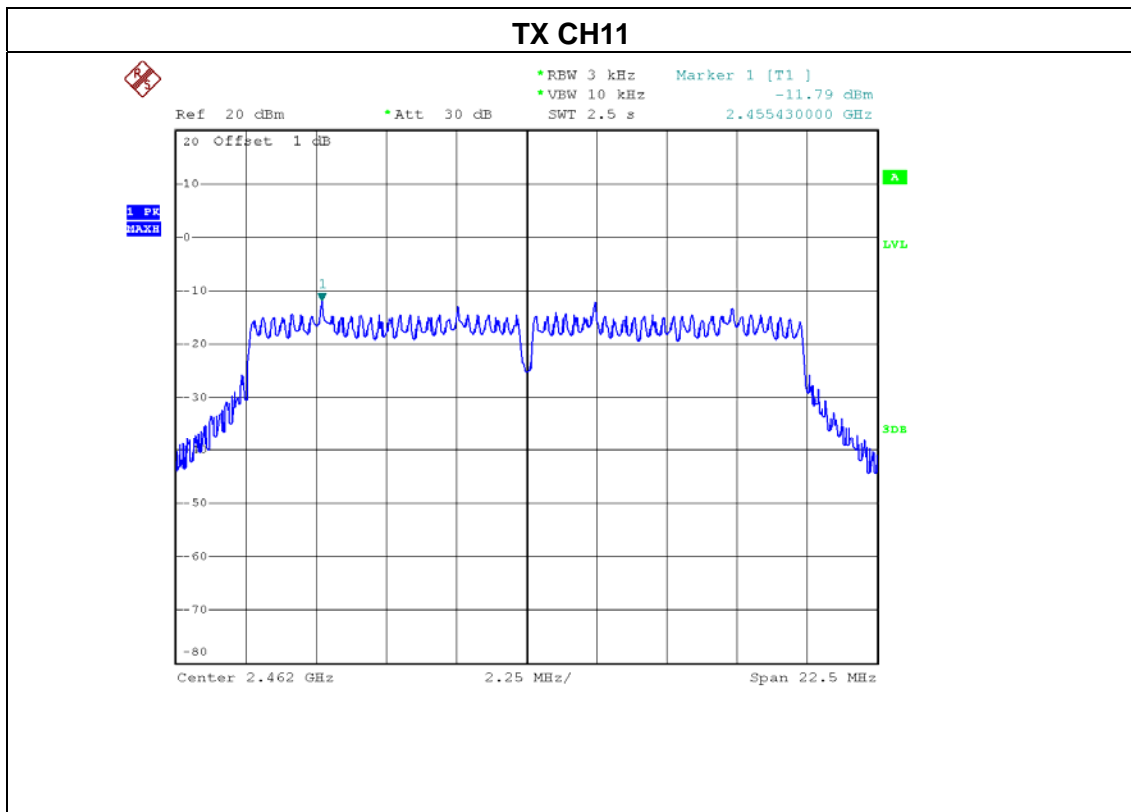
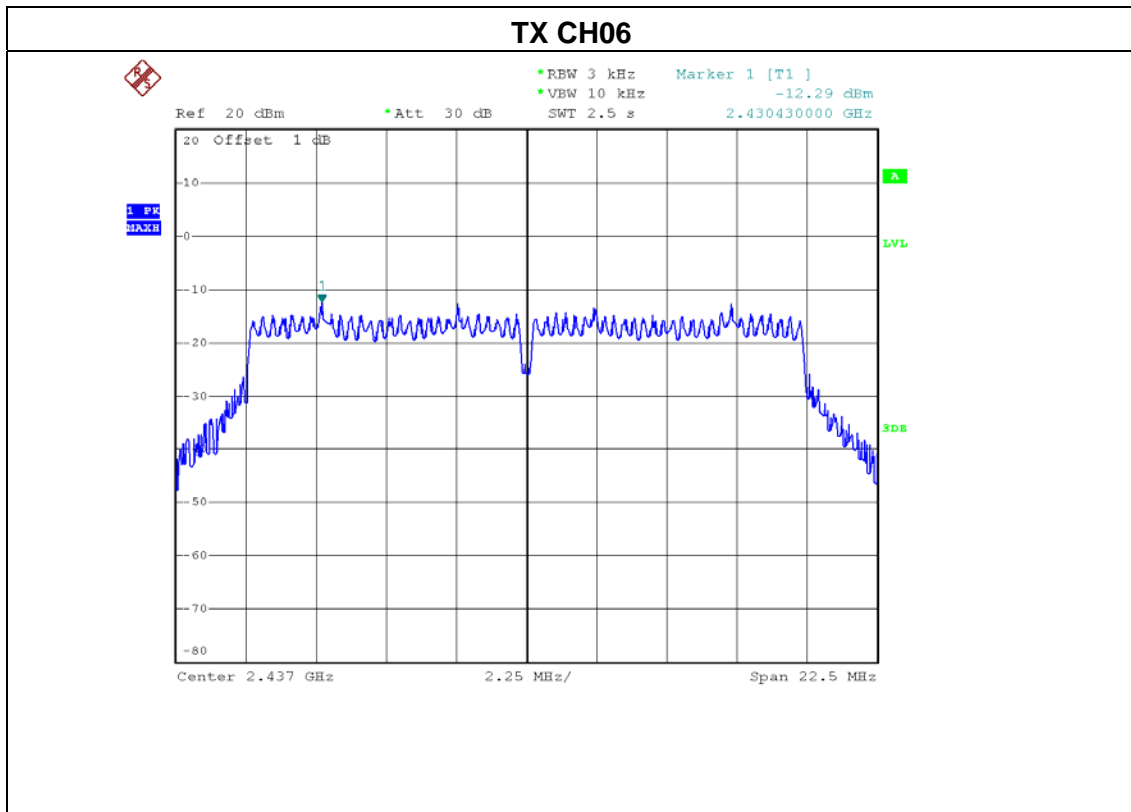



Test Mode : TX N-20M Mode-ANT 2			
Test Channel	Frequency (MHz)	Power Density (dBm)	Limit (dBm)
CH01	2412	-10.89	8
CH06	2437	-11.62	8
CH11	2462	-12.44	8

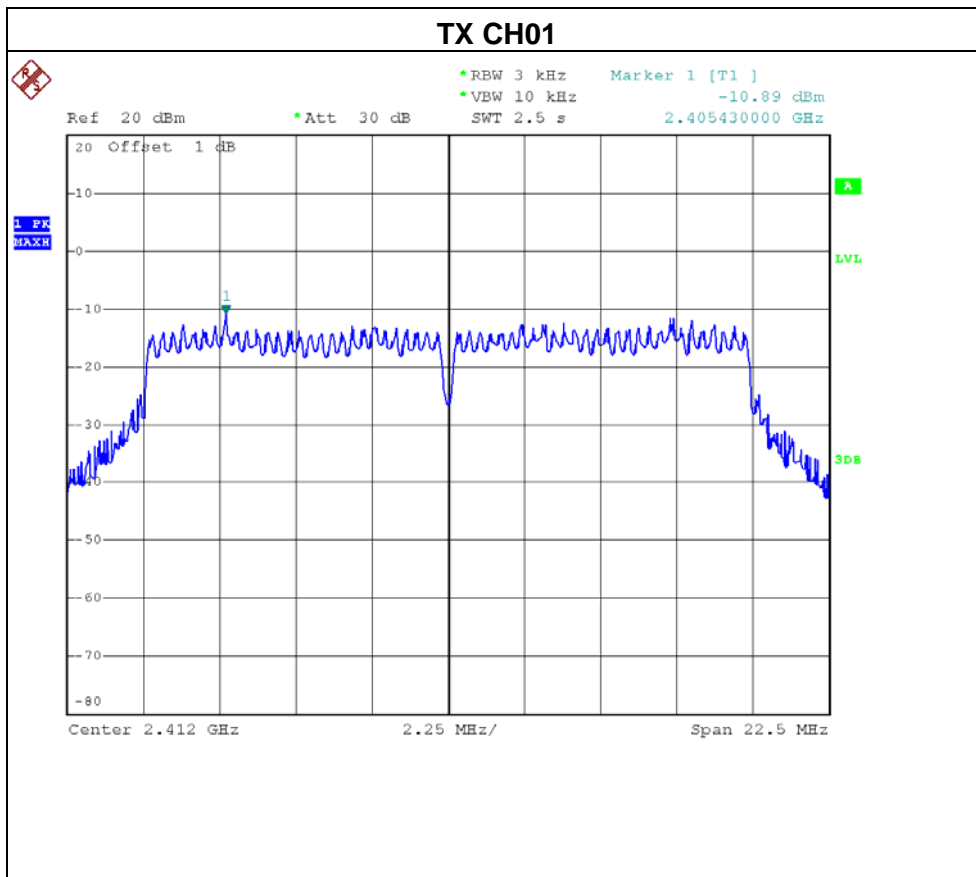

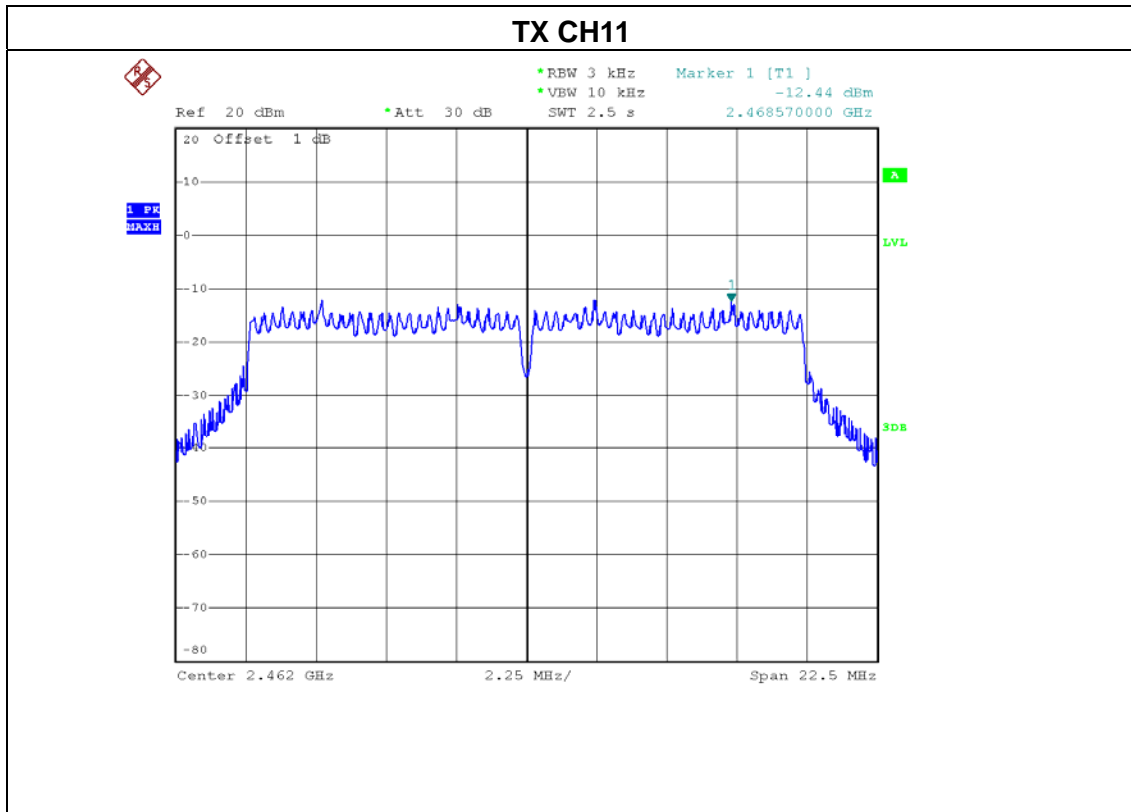
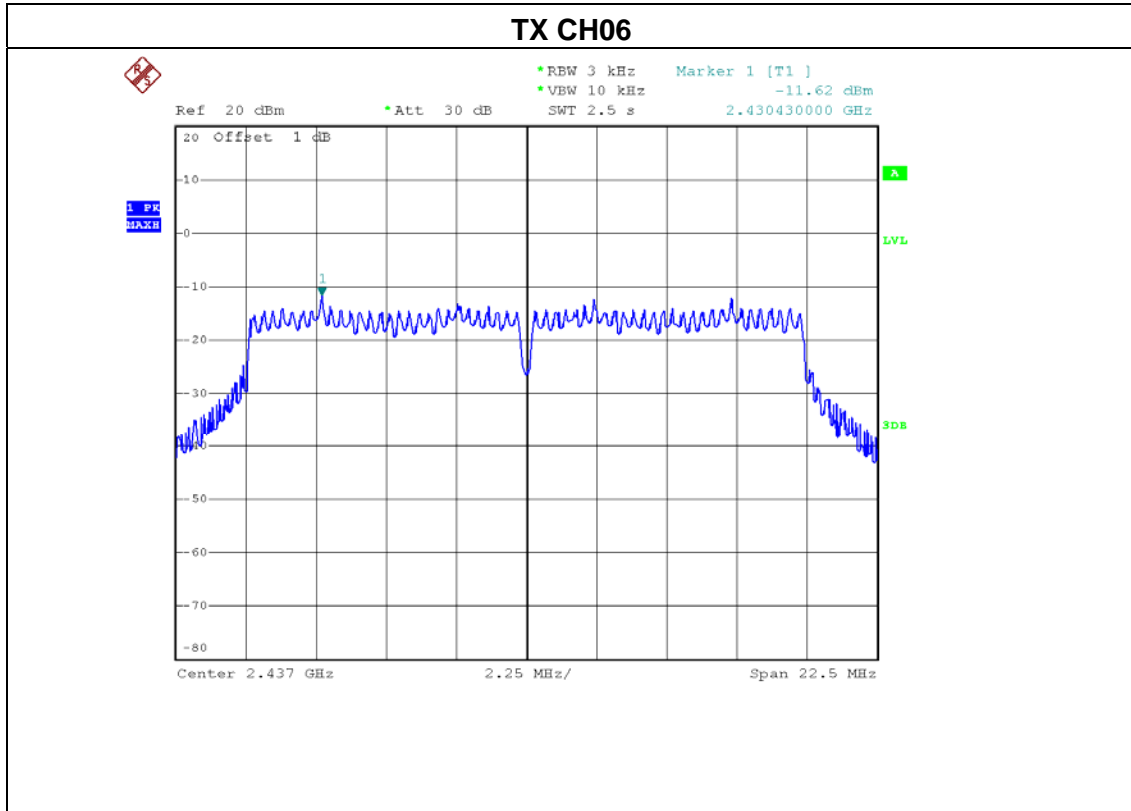



Test Mode : TX N-20M Mode-Total			
Test Channel	Frequency (MHz)	Power Density (dBm)	Limit (dBm)
CH01	2412	-7.97	8
CH07	2437	-8.93	8
CH11	2462	-9.09	8



Test Mode : TX N-40M Mode-ANT 1			
Test Channel	Frequency (MHz)	Power Density (dBm)	Limit (dBm)
CH03	2422	-14.74	8
CH06	2437	-16.18	8
CH09	2452	-15.65	8

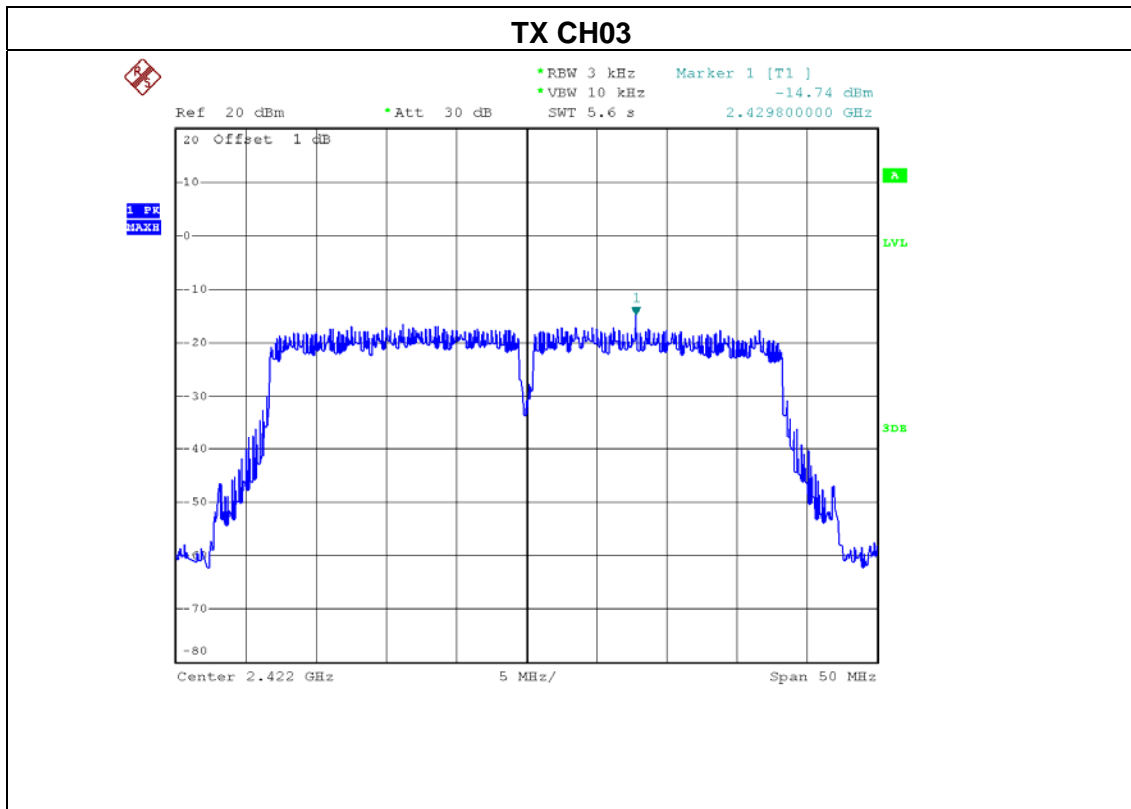

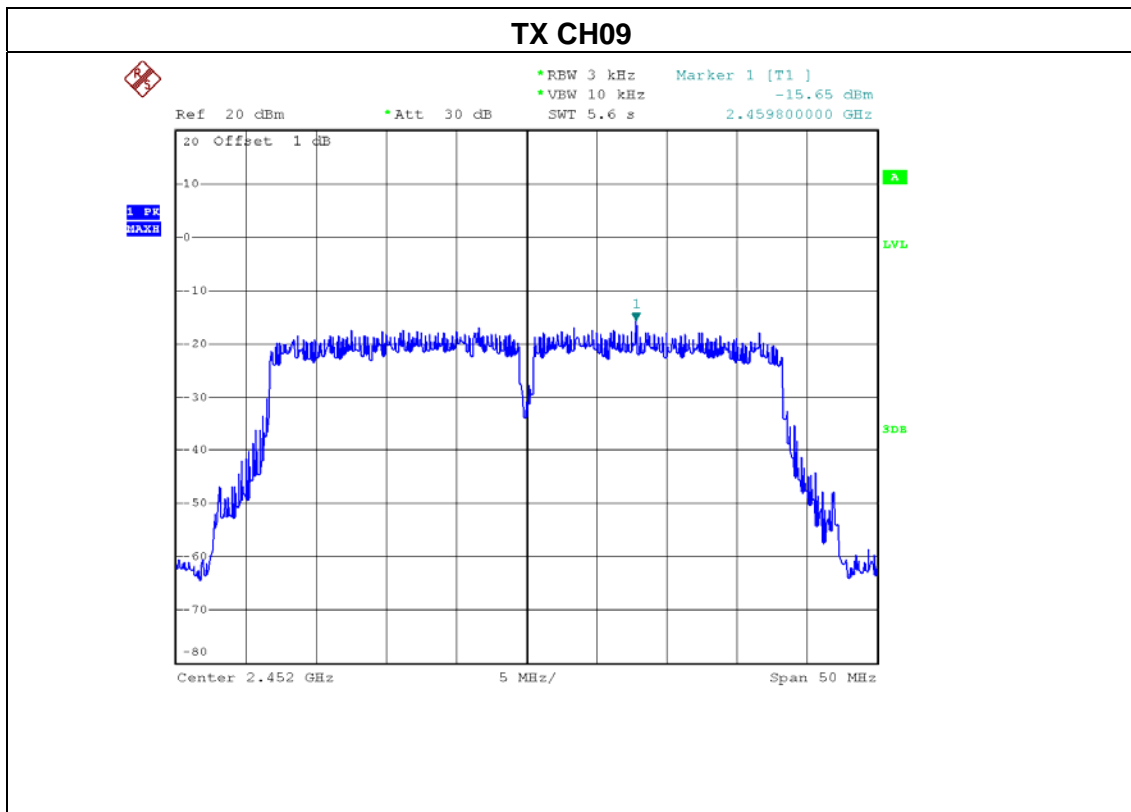
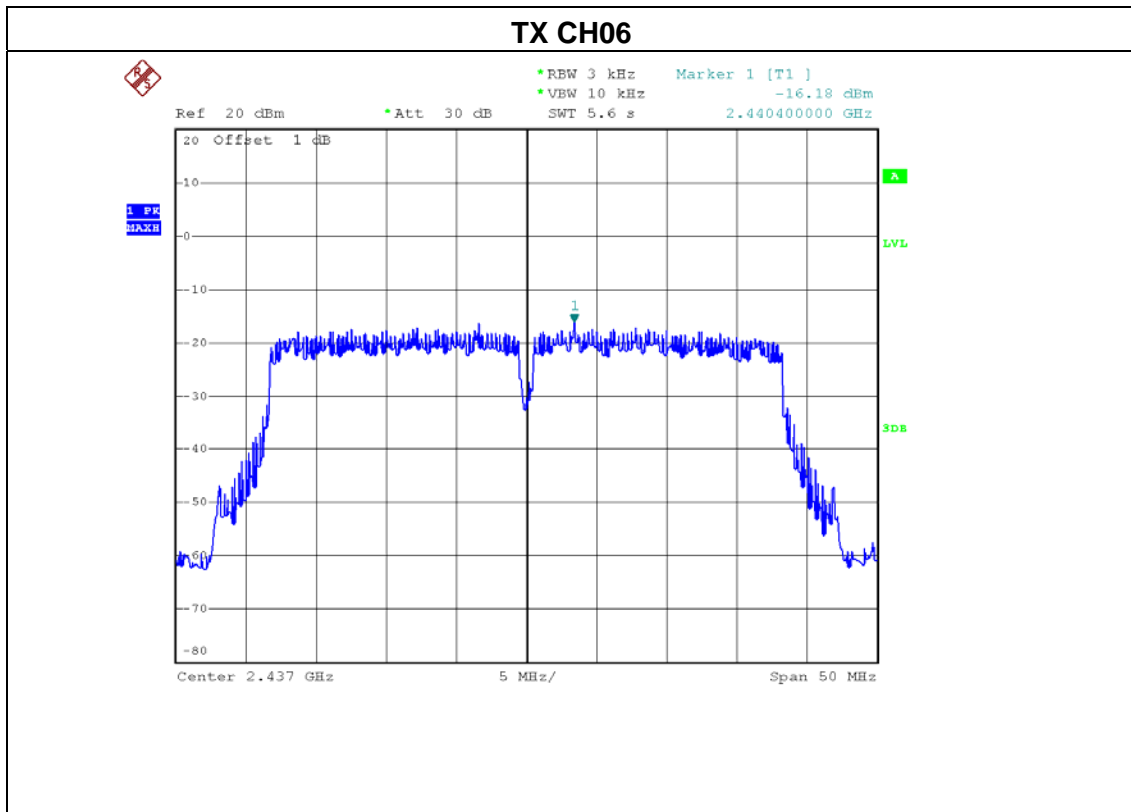



Test Mode : TX N-40M Mode-ANT 2			
Test Channel	Frequency (MHz)	Power Density (dBm)	Limit (dBm)
CH03	2422	-16.30	8
CH06	2437	-17.60	8
CH09	2452	-16.95	8

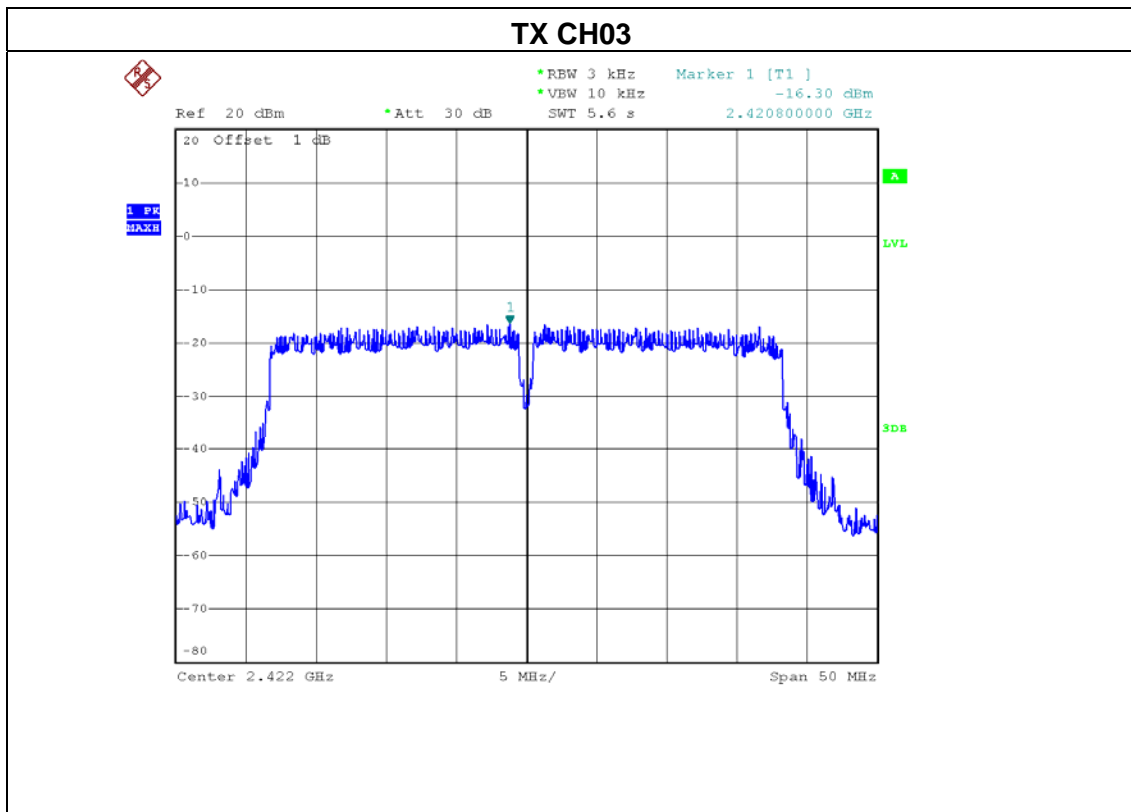

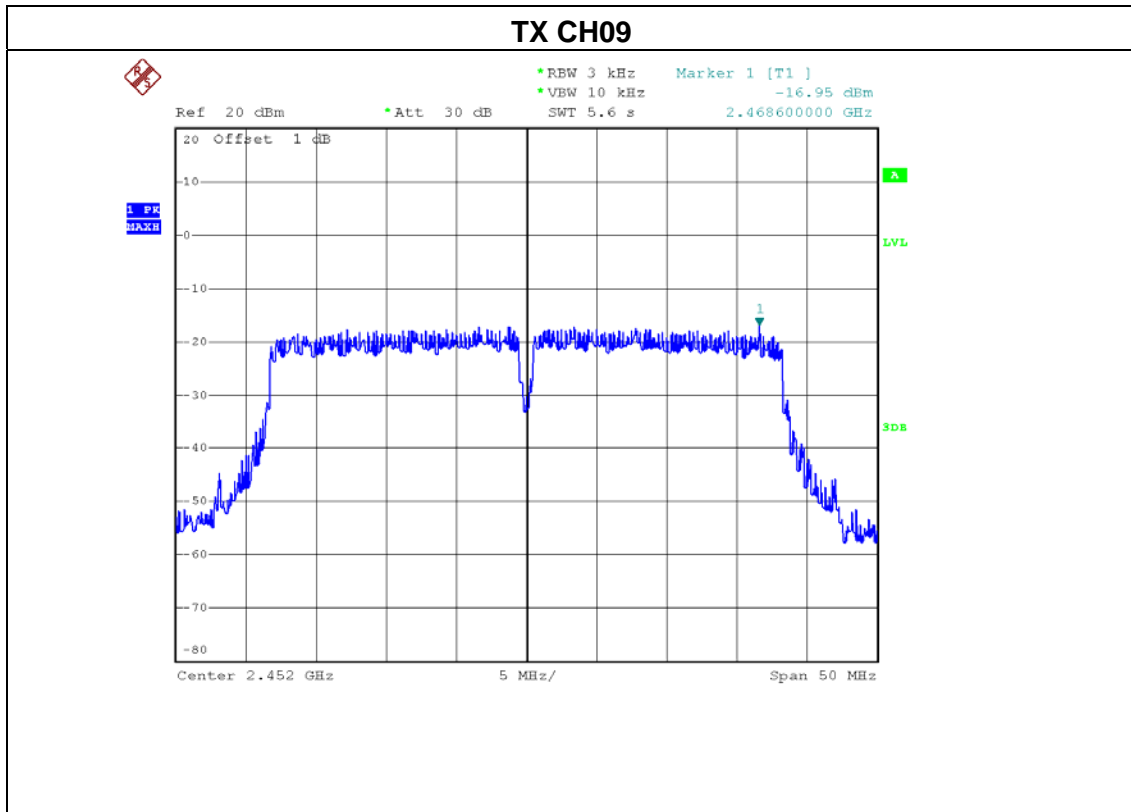
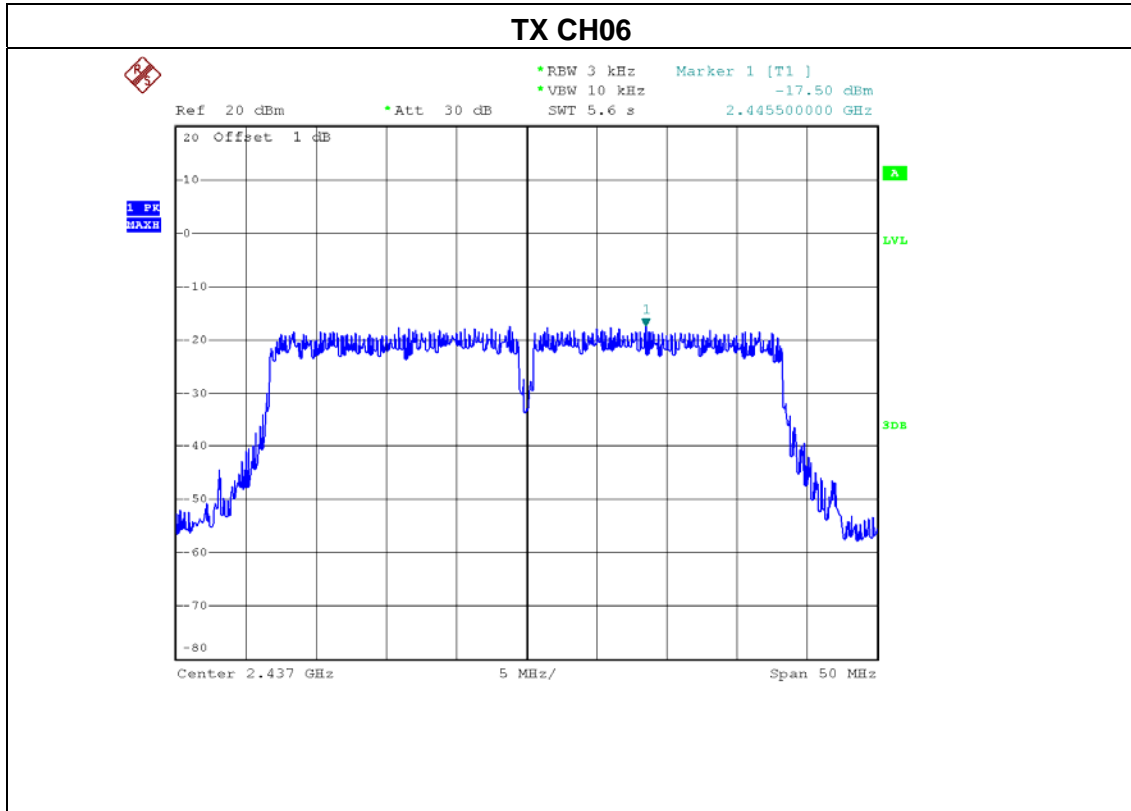



Test Mode : TX N-40M Mode-Total			
Test Channel	Frequency (MHz)	Power Density (dBm)	Limit (dBm)
CH03	2422	-12.44	8
CH06	2437	-13.82	8
CH09	2452	-13.24	8



9. MEASUREMENT INSTRUMENTS LIST

Conducted Emission Measurement					
Item	Kind of Equipment	Manufacturer	Type No.	Serial No.	Calibrated until
1	LISN	EMCO	3816/2	00052765	Apr. 25, 2014
2	LISN	R&S	ENV216	100087	Nov.15, 2014
3	Test Cable	N/A	C_17	N/A	Mar.15, 2014
4	EMI TEST RECEIVER	R&S	ESCS30	826547/022	Apr. 25, 2014
5	50Ω Terminator	SHX	TF2-3G-A	08122902	Apr. 25, 2014

Radiated Emission Measurement					
Item	Kind of Equipment	Manufacturer	Type No.	Serial No.	Calibrated until
1	Antenna	Schwarbeck	VULB9160	9160-3232	Apr. 25, 2014
2	Amplifier	HP	8447D	2944A09673	Apr. 25, 2014
3	Test Receiver	R&S	ESCI	100382	Apr. 25, 2014
4	Test Cable	N/A	C-01_CB03	N/A	Jul. 02, 2014
5	Antenna	ETS	3115	00075789	Apr. 25, 2014
6	Amplifier	Agilent	8449B	3008A02274	Apr. 25, 2014
7	Spectrum	Agilent	E4408B	US39240143	Nov.15, 2014
8	Test Cable	HUBER+SUHNER	C-45	N/A	Apr. 30, 2014
9	Controller	CT	SC100	N/A	N/A
10	Horn Antenna	EMCO	3115	9605-4803	Apr. 25, 2014
11	Active Loop Antenna	R&S	HFH2-Z2	830749/020	Apr. 25, 2014
12	Broad-Band Horn Antenna	Schwarzbeck	BBHA 9170	9170319	Oct. 22, 2014

6dB Bandwidth Measurement					
Item	Kind of Equipment	Manufacturer	Type No.	Serial No.	Calibrated until
1	Spectrum Analyzer	R&S	FSP 40	100185	Nov.15, 2014

Peak Output Power Measurement					
Item	Kind of Equipment	Manufacturer	Type No.	Serial No.	Calibrated until
1	P-series Power meter	Agilent	N1911A	MY45100473	Apr. 25, 2014
2	Wireband Power sensor	Agilent	N1921A	MY51100041	Apr. 25, 2014



Antenna Conducted Spurious Emission Measurement					
Item	Kind of Equipment	Manufacturer	Type No.	Serial No.	Calibrated until
1	Spectrum Analyzer	R&S	FSP 40	100185	Nov.15, 2014

Power Spectral Density Measurement					
Item	Kind of Equipment	Manufacturer	Type No.	Serial No.	Calibrated until
1	Spectrum Analyzer	R&S	FSP 40	100185	Nov.15, 2014

Remark: "N/A" denotes no model name, serial no. or calibration specified.
All calibration period of equipment list is one year.



10. EUT TEST PHOTO

Conducted Measurement Photos





**Radiated Measurement Photos
9K~30MHz**

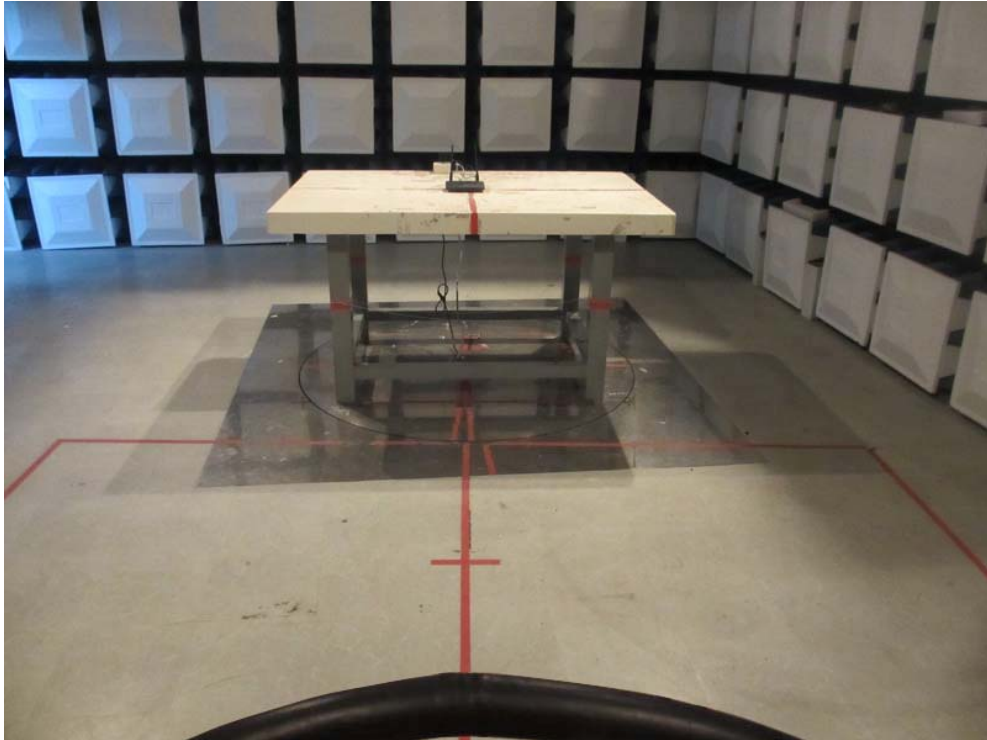



**Radiated Measurement Photos
30~1000MHz**

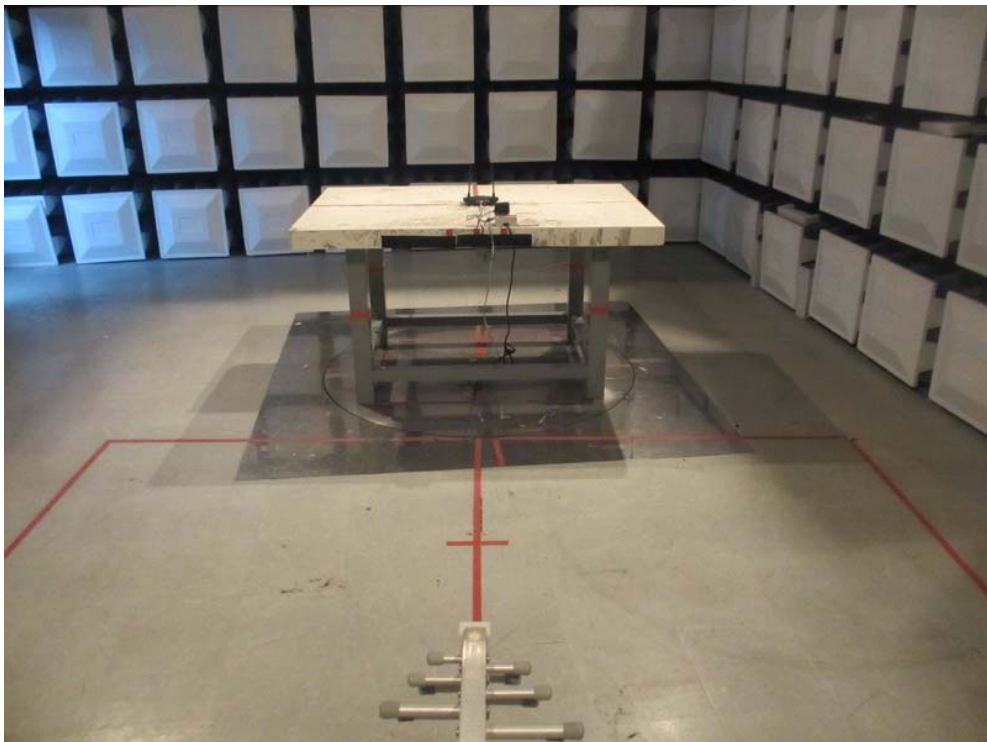
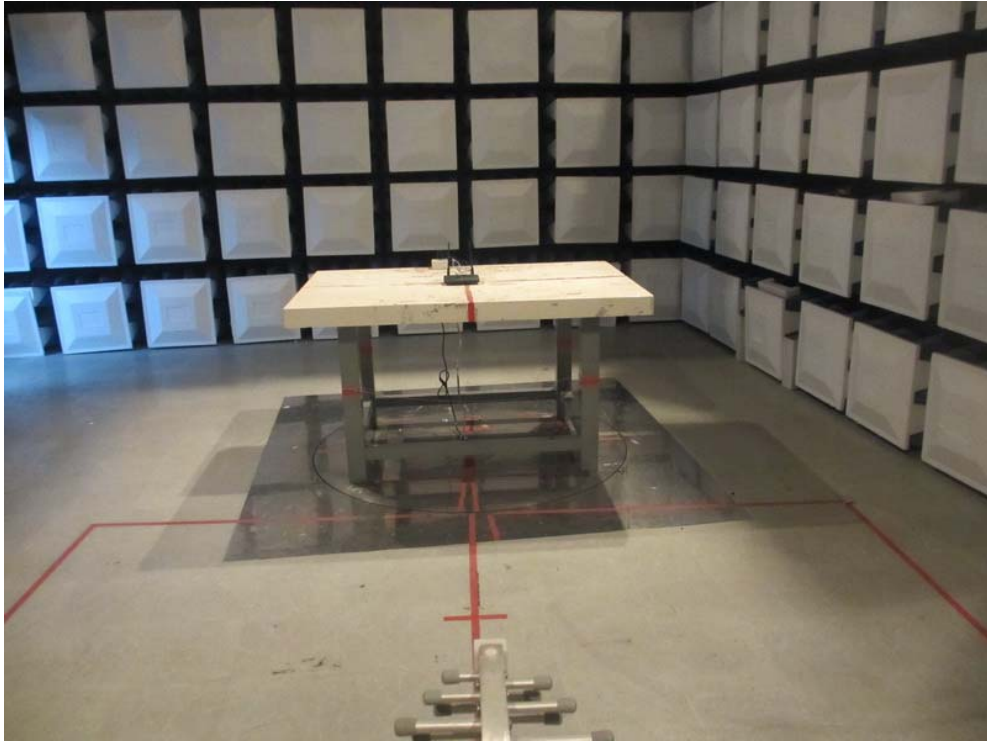



**Radiated Measurement Photos
Above 1000MHz**

