

FCC/ISED
RF
TEST REPORT

ISSUED BY
Shenzhen BALUN Technology Co., Ltd.



FOR
HUAWEI MateBook

ISSUED TO
Huawei Technologies Co., Ltd.

Administration Building, Headquarters of Huawei Technologies Co.,
Ltd., Bantian, Longgang District, Shenzhen, 518129, China



Tested by: Hu Chao
Hu Chao
(Engineer)
Date: Nov. 05, 2018

Approved by: Wei Yanquan
Wei Yanquan
(Chief Engineer)
Date: Nov 05, 2018

Report No.: BL-SZ1880358-605
EUT Name: HUAWEI MateBook
Model Name: WRT-W19, WRT-W29
Brand Name: HUAWEI
Test Standard: 47 CFR Part 15 Subpart E
RSS-247 (Issue 2, February 2017)
FCC ID: QISWRT-WX9
ISED Number: 6369A-WRTWX9
Test Conclusion: Pass
Test Date: Oct. 15, 2018 ~ Oct. 16, 2018
Date of Issue: Nov. 05, 2018

NOTE: This test report of test results only related to testing samples, which can be duplicated completely for the legal use with the approval of the applicant; it shall not be reproduced except in full, without the written approval of Shenzhen BALUN Technology Co., Ltd. Any objections should be raised within thirty days from the date of issue. To validate the report, please contact us.

Revision History

<u>Version</u>	<u>Issue Date</u>	<u>Revisions Content</u>
<u>Rev. 01</u>	<u>Nov. 05, 2018</u>	<u>Initial Issue</u>

TABLE OF CONTENTS

1	ADMINISTRATIVE DATA (GENERAL INFORMATION).....	4
1.1	Identification of the Testing Laboratory.....	4
1.2	Identification of the Responsible Testing Location.....	4
1.3	Laboratory Condition.....	4
1.4	Announce.....	4
2	PRODUCT INFORMATION.....	5
2.1	Applicant Information.....	5
2.2	Manufacturer Information.....	5
2.3	Factory Information.....	5
2.4	General Description for Equipment under Test (EUT).....	5
2.5	Differences Description.....	6
2.6	Ancillary Equipment.....	7
2.7	Technical Information.....	8
3	SUMMARY OF TEST RESULTS.....	9
3.1	Test Standards.....	9
3.2	Verdict.....	9
3.3	Test Uncertainty.....	9
4	GENERAL TEST CONFIGURATIONS.....	10
4.1	Test Environments.....	10
4.2	Test Equipment List.....	10
4.3	Description of Test Setup.....	11
4.3.1	Conducted Test Setup Configuration.....	11
5	Test Type and Test Results.....	12
5.1	DFS.....	12
5.1.1	U-NII DFS Rule Requirements.....	12
5.1.2	Test Limits and Radar Signal Parameters.....	13

ANNEX A TEST RESULT..... 26

 A.1 CHANNEL CLOSING TRANSMISSION AND CHANNEL MOVE TIME..... 26

 A.2 NON- OCCUPANCY PERIOD..... 28

ANNEX B TEST SETUP PHOTOS..... 29

ANNEX C EUT EXTERNAL PHOTOS..... 29

ANNEX D EUT INTERNAL PHOTOS..... 29

1 ADMINISTRATIVE DATA (GENERAL INFORMATION)

1.1 Identification of the Testing Laboratory

Company Name	Shenzhen BALUN Technology Co., Ltd.
Address	Block B, 1st FL, Baisha Science and Technology Park, Shahe Xi Road, Nanshan District, Shenzhen, Guangdong Province, P. R. China
Phone Number	+86 755 6685 0100

1.2 Identification of the Responsible Testing Location

Test Location	Shenzhen BALUN Technology Co., Ltd.
Address	Block B, 1st FL, Baisha Science and Technology Park, Shahe Xi Road, Nanshan District, Shenzhen, Guangdong Province, P. R. China
Accreditation Certificate	<p>The laboratory has been listed by Industry Canada to perform electromagnetic emission measurements. The recognition numbers of test site are 11524A-1.</p> <p>The laboratory is a testing organization accredited by FCC as a accredited testing laboratory. The designation number is CN1196.</p> <p>The laboratory is a testing organization accredited by American Association for Laboratory Accreditation(A2LA) according to ISO/IEC 17025.The accreditation certificate is 4344.01.</p> <p>The laboratory is a testing organization accredited by China National Accreditation Service for Conformity Assessment (CNAS) according to ISO/IEC 17025. The accreditation certificate number is L6791.</p>
Description	All measurement facilities used to collect the measurement data are located at Block B, FL 1, Baisha Science and Technology Park, Shahe Xi Road, Nanshan District, Shenzhen, Guangdong Province, P. R. China 518055

1.3 Laboratory Condition

Ambient Temperature	20°C to 25°C
Ambient Relative Humidity	45% to 55%
Ambient Pressure	100 kPa to 102 kPa

1.4 Announce

- (1) The test report reference to the report template version v4.5.
- (2) The test report is invalid if not marked with the signatures of the persons responsible for preparing and approving the test report.
- (3) The test report is invalid if there is any evidence and/or falsification.
- (4) The results documented in this report apply only to the tested sample, under the conditions and modes of operation as described herein.
- (5) This document may not be altered or revised in any way unless done so by BALUN and all revisions are duly noted in the revisions section.
- (6) Content of the test report, in part or in full, cannot be used for publicity and/or promotional purposes without prior written approval from the laboratory.

2 PRODUCT INFORMATION

2.1 Applicant Information

Applicant	Huawei Technologies Co., Ltd.
Address	Administration Building, Headquarters of Huawei Technologies Co., Ltd., Bantian, Longgang District, Shenzhen, 518129, China

2.2 Manufacturer Information

Manufacturer	Huawei Technologies Co., Ltd.
Address	Administration Building, Headquarters of Huawei Technologies Co., Ltd., Bantian, Longgang District, Shenzhen, 518129, China

2.3 Factory Information

Factory	N/A
Address	N/A

2.4 General Description for Equipment under Test (EUT)

EUT Name	HUAWEI MateBook
Model Name Under Test	WRT-W19, WRT-W29
Series Model Name	WRT-WXXXXX (The "X" in model name can be 0 to 9, A to Z, a to z, "-" or blank, only differences are the appearance and model names for trading purpose)
Description of Model name differentiation	Refer section 2.5
Hardware Version	NX8309_PCB_MB_V5_HF
Software Version	1.4.0.11 (C001)
Dimensions (Approx.)	N/A
Weight (Approx.)	N/A

2.5 Differences Description

	WRT-W29 (with GPU version)	WRT-W19 (with GPU version)	WRT-W29 (without GPU version)	WRT-W19 (without GPU version)
Main board	The same	The same	Delete GPU chip and related components	Delete GPU chip and related components
Frequency bands	The same, support Wi-Fi 2.4G&5G support BT	The same, support Wi-Fi 2.4G&5G support BT	The same, support Wi-Fi 2.4G&5G support BT	The same, support Wi-Fi 2.4G&5G support BT
BT/ Wi-Fi module	The same	The same	The same	The same
BT/ Wi-Fi antenna	The same	The same	The same	The same
Appearance	The same	The same	The same	The same
Dimension	The same	The same	The same	The same
CPU	Intel i7-8565U, Support max4.6GHz	Intel i5-8265U, Support max3.9GHz	Intel i7-8565U, Support max4.6GHz	Intel i5-8265U, Support max3.9GHz
GPU	support	support	Not support	Not support
Memory	16/8G	8G	8G	8G
SSD	512G/256G	256G	512G	512G/256G
Rear camera	Not support	Not support	Not support	Not support
Front camera	The same	The same	The same	The same
Adapter	The same	The same	The same	The same
Battery	The same	The same	The same	The same
Accessories	The same, Docking Station	The same, Docking Station	The same, Docking Station	The same, Docking Station

2.6 Ancillary Equipment

Ancillary Equipment 1	Rechargeable Li-ion Polymer Battery	
	Brand Name	HUAWEI
	Model No.	HB4593J6ECW
	Serial No.	N/A
	Capacity	3660 mAh
	Rated Voltage	11.4 V
	Limit Charge Voltage	13.05 V
Ancillary Equipment 2	Adapter 1	
	Brand Name	HUAWEI
	Model No.	HW-200325BP0 (UK Plug)
	Serial No.	C978Y9J7F00037
	Rated Input	100-240 V~, 1.8 A, 50/60 Hz
	Rated Output	5 V= 2 A / 9 V= 2 A / 12 V= 2 A / 15 V= 3 A / 20 V= 3.25 A
	Manufacturer	Huawei Technologies Co.,Ltd.
Ancillary Equipment 3	Adapter 2	
	Brand Name	HUAWEI
	Model No.	HW-200325UP0 (US Plug)
	Serial No.	C976Y1J8P00106
	Rated Input	100-240 V~, 1.8 A, 50/60 Hz
	Rated Output	5 V= 2 A / 9 V= 2 A / 12 V= 2 A / 15 V= 3 A / 20 V= 3.25 A
	Manufacturer	Huawei Technologies Co.,Ltd.
Ancillary Equipment 4	Adapter 3	
	Brand Name	HUAWEI
	Model No.	HW-200325EP0 (EU Plug)
	Serial No.	C974Y1J8W01182
	Rated Input	100-240 V~, 1.8 A, 50/60 Hz
	Rated Output	5 V= 2 A / 9 V= 2 A / 12 V= 2 A / 15 V= 3 A / 20 V= 3.25 A
	Manufacturer	Huawei Technologies Co.,Ltd.
Ancillary Equipment 5	Adapter 4	
	Brand Name	HUAWEI
	Model No.	HW-200325CP0 (GB Plug)
	Serial No.	C973Y1J5S01577
	Rated Input	100-240 V~, 1.8 A, 50/60 Hz
	Rated Output	5 V= 2 A / 9 V= 2 A / 12 V= 2 A / 15 V= 3 A / 20 V= 3.25 A
	Manufacturer	Huawei Technologies Co.,Ltd.
Ancillary Equipment 6	USB-A to RJ45	
	Model No.	AD70
	Serial No.	48XJU17A18011914
	Manufacturer	Huawei Technologies Co.,Ltd.
Ancillary Equipment 7	Docking Station	

	Model No.	AD11
	Serial No.	N/A
	Manufacturer	Huawei Technologies Co.,Ltd.
Ancillary Equipment 8	USB Cable	
	Length (Approx.)	1.8 m
Ancillary Equipment 9	USB-C to USB-A	
Note: All adapter models only with different plug for marketing purpose. We select HW-200325UP0 (US Plug) during testing.		

2.7 Technical Information

Network and Wireless connectivity	Bluetooth 5.0 (BR+EDR+BLE) 2.4G WIFI: 802.11b, 802.11g, 802.11n(HT20/40) 5G WIFI:802.11a, 802.11n(HT20/40), 802.11ac(VHT20/40/80/160) 5.8G SRD
-----------------------------------	---

The requirement for the following technical information of the EUT was tested in this report:

Frequency Range	Band I: 5150 MHz to 5250 MHz, Band II: 5250 MHz to 5350 MHz, Band III: 5470 MHz to 5725 MHz Band IV: 5725 MHz to 5850 MHz
Product Type	<input type="checkbox"/> Mobile <input checked="" type="checkbox"/> Portable <input type="checkbox"/> Fix Location
Maximum Output Power	Band I: 12.4 dBm Band II: 13.8 dBm Band III: 12.5 dBm Band IV: 12.5 dBm
Antenna Type	PIFA Antenna
Antenna Gain	2 dBi
Note: This device (Client) is without radar detection, then the manufacturer statement confirming that information regarding the parameters of the detected Radar Waveforms is not available to the end user. And the device doesn't have Ad Hoc mode on DFS frequency band.	

3 SUMMARY OF TEST RESULTS

3.1 Test Standards

No.	Identity	Document Title
1	47 CFR Part 15 Subpart E	Unlicensed National Information Infrastructure Devices
2	KDB Publication 905462 D02v02	UNII DFS Compliance Procedures New Rules
3	KDB Publication 905462 D03v01r02	UNII Clients Without Radar Detection New Rules
4	KDB Publication 789033 D02v02r01	Guidelines for Compliance Testing of Unlicensed National Information Infrastructure (U-NII) Devices Part 15, Subpart E
5	RSS-247 (Issue 2, Feb 2017)	Digital Transmission Systems (DTSS), Frequency Hopping Systems(FHSs) and Licence-Exemp Local Area Network (LE-LAN) Devices
6	KDB Publication 905462 D04v01	Operational Modes for DFS Testing New Rules

3.2 Verdict

No.	Description	FCC Part No.	RSS Part No.	Verdict	Remark
1	Channel Move Time	15.407	RSS-247, 6.3	Pass	Applicable
2	Channel Closing Transmission Time	15.407	RSS-247, 6.3	Pass	Applicable
3	Non- Occupancy Period	15.407	RSS-247, 6.3	Pass	Applicable

3.3 Test Uncertainty

The following measurement uncertainty levels have been estimated for tests performed on the EUT as specified in CISPR 16-4-2. This uncertainty represents an expanded uncertainty expressed at approximately the 95% confidence level using a coverage factor of k=2.

Measurement	Value
Occupied Channel Bandwidth	±4%
RF output power, conducted	±1.4 dB
Power Spectral Density, conducted	±2.5 dB
Unwanted Emissions, conducted	±2.8 dB
All emissions, radiated	±5.4 dB
Temperature	±1°C
Humidity	±4%

4 GENERAL TEST CONFIGURATIONS

4.1 Test Environments

During the measurement, the normal environmental conditions were within the listed ranges:

Relative Humidity	45% to 55%	
Atmospheric Pressure	100 kPa to 102 kPa	
Temperature	NT (Normal Temperature)	+22°C to +25°C
	LT (Low Temperature)	0°C
	HT (High Temperature)	+35°C
Working Voltage of the EUT	NV (Normal Voltage)	11.4 V
	LV (Low Voltage)	10.8 V
	HV (High Voltage)	12.0 V

4.2 Test Equipment List

Description	Manufacturer	Model	Serial No.	Cal. Date	Cal. Due
Spectrum Analyzer	ROHDE&SCHWARZ	FSV-30	103118	2018.06.11	2019.06.10
Vector Signal Generator	ROHDE&SCHWARZ	SMBV100A	260592	2018.06.11	2019.06.10
Signal Generator	ROHDE&SCHWARZ	SMB100A	177746	2018.06.11	2019.06.10
Switch Unit with OSP-B157	ROHDE&SCHWARZ	OSP120	101270	2018.06.11	2019.06.10
Spectrum Analyzer	AGILENT	E4440A	MY45304434	2018.06.21	2019.06.20
Power Splitter	KMW	DCPD-LDC	1305003215	--	--
Power Sensor	ROHDE&SCHWARZ	NRP-Z21	103971	2018.06.11	2019.06.10
Attenuator (20 dB)	KMW	ZA-S1-201	110617091	--	--
Attenuator (6 dB)	KMW	ZA-S1-61	1305003189	--	--
DC Power Supply	ITECH	IT6720	600103010717 610007	2018.06.21	2019.06.20
RF cable	Balun	SRD1	N/A	2018.10.09	2019.01.08
RF cable	Balun	SRD2	N/A	2018.10.09	2019.01.08
RF Cable	COM-MW	RFJA360-2.92 mm-J/J3M	N/A	2018.10.09	2019.01.08
laptop	Lenovo	X220	4286A17	N/A	N/A

Master	Access Point	
	Brand Name	Aerohive
	Model No.	AP230
	Serial No.	AH-AP-230-AC-W
	FCC ID	WBV-AP230
	SPEC.	The maximum EIRP is 18.5dBm, Antenna Gain is 6.57dBi

4.3 Description of Test Setup

4.3.1 Conducted Test Setup Configuration

Client without Radar Detection Mode

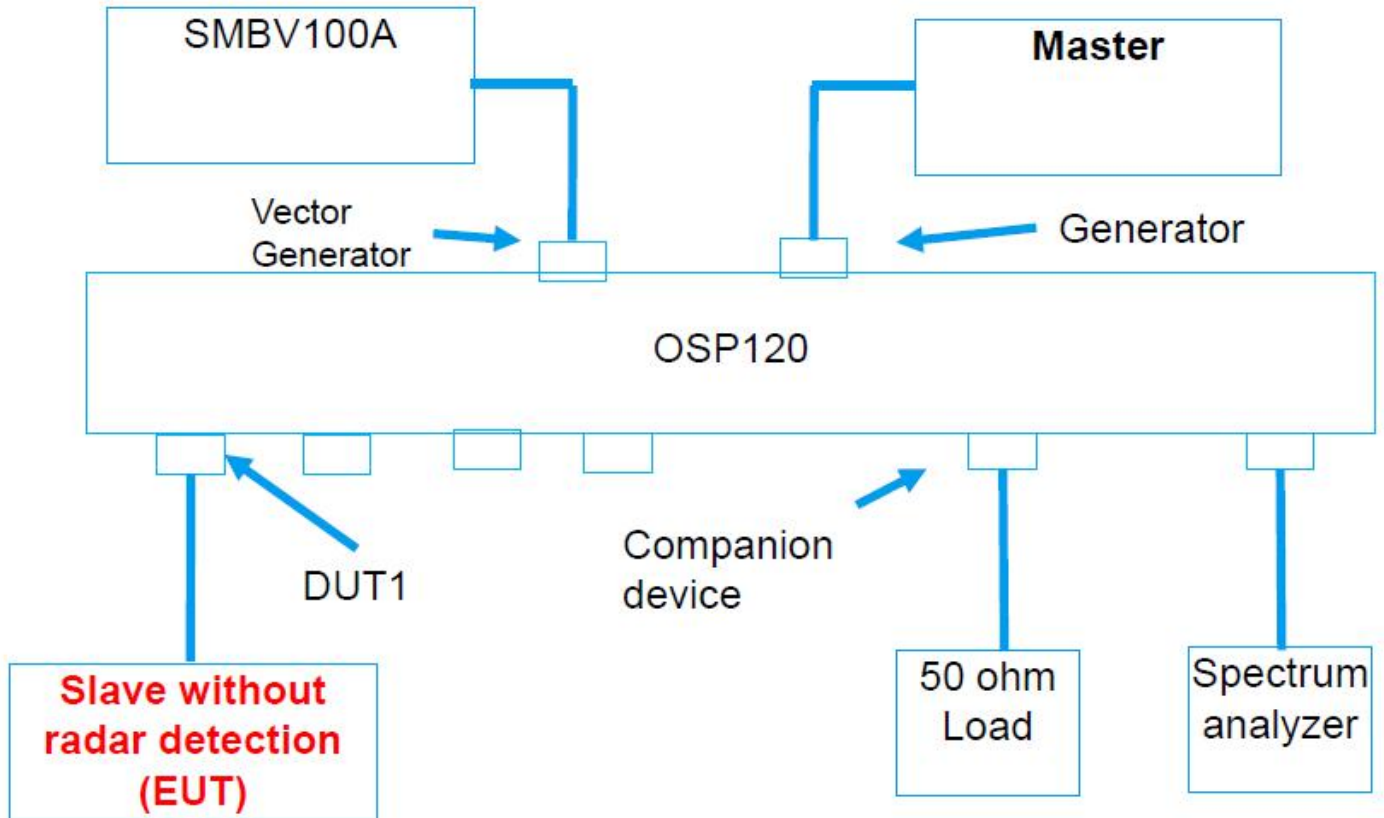

The UUT is a U-NII Device operating in Client mode without radar detection. The radar test signals are injected into the Master Device.

(Diagram 1)

5 Test Type and Test Results

5.1 DFS

5.1.1 U-NII DFS Rule Requirements

5.1.1.1 Working Mode and Required Test Items

The manufacturer shall state whether the UUT is capable of operating as a Master and/or a Client. If the UUT is capable of operating in more than one operating mode then each operating mode shall be tested separately. See tables 1 and 2 for the applicability of DFS requirements for each of the operational modes.

APPLICABILITY OF DFS REQUIREMENTS PRIOR TO USE A CHANNEL

Requirement	Operational Mode		
	Master	Client without radar detection	Client with radar detection
Non-Occupancy Period	✓	✓	✓
DFS Detection Threshold	✓	Not required	✓
Channel Availability Check Time	✓	Not required	Not required
Uniform Spreading	✓	Not required	Not required
U-NII Detection Bandwidth	✓	Not required	✓

APPLICABILITY OF DFS REQUIREMENTS DURING NORMAL OPERATION

Requirement	Operational Mode		
	Master	Client without radar detection	Client with radar detection
DFS Detection Threshold	✓	Not required	✓
Channel Closing Transmission Time	✓	✓	✓
Channel Move Time	✓	✓	✓
U-NII Detection Bandwidth	✓	Not required	✓

5.1.2 Test Limits and Radar Signal Parameters

Detection Threshhold Values

DFS DETECTION THRESHOLDS FOR MASTER DEVICES AND CLIENT DEVICES WITH RADAR DETECTION

Maximum Transmit Power	Value (See Note ¹ & ²)
≥ 200 milliwatt	-64 dBm
< 200 milliwatt	-62 dBm

Note ¹: This is the level at the input of the receiver assuming a 0 dBi receive antenna.

Note ²: Throughout these test procedures an additional 1 dB has been added to the amplitude of the test transmission waveforms to account for variations in measurement equipment. This will ensure that the test signal is at or above the detection threshold level to trigger a DFS response.

DFS RESPONSE REQUIREMENT VALUES

Parameter	Value
Non-occupancy period	Minimum 30 minutes
Channel Availability Check Time	60 seconds
Channel Move Time	10 seconds See Note ¹ .
Channel Closing Transmission Time	200 milliseconds + an aggregate of 60 milliseconds over remaining 10 second period. See Note ^{1&2} .
U-NII Detection Bandwidth	100% of the UNII transmission power bandwidth. See Note ³ .

Note ¹: The instant that the Channel Move Time and the Channel Closing Transmission Time begins is as follows:

- For the Short Pulse Radar Test Signals this instant is the end of the Burst.
- For the Frequency Hopping radar Test Signal, this instant is the end of the last radar Burst generated.
- For the Long Pulse Radar Test Signal this instant is the end of the 12 second period defining the Radar Waveform.

Note ²: The Channel Closing Transmission Time is comprised of 200 milliseconds starting at the beginning of the Channel Move Time plus any additional intermittent control signals required to facilitate a Channel move (an aggregate of 60 milliseconds) during the remainder of the 10 second period. The aggregate duration of control signals will not count quiet periods in between transmissions.

Note ³: During the U-NII Detection Bandwidth detection test, radar type 1 is used and for each frequency step the minimum percentage of detection is 90 percent. Measurements are performed with no data traffic.

Parameters of DFS Test Signals

Step intervals of 0.1 microsecond for Pulse Width, 1 microsecond for PRI, 1 MHz for chirp width and 1 for the number of pulses will be utilized for the random determination of specific test waveforms.

SHORT PULSE RADAR TEST WAVEFORMS

Radar Type	Pulse Width (μsec)	PRI (μsec)	Number of Pulses	Minimum Percentage of Successful Detection	Minimum Number of Trials
0	1	1428	18	See Note	See Note
1	1	Test A: 15 unique PRI values randomly selected from the list of 23 PRI values in Table 5a	$\text{Roundup} \left\{ \left(\frac{1}{360} \right) \cdot \left(\frac{19 \cdot 10^6}{\text{PRI}_{\mu\text{sec}}} \right) \right\}$	60%	30
		Test B: 15 unique PRI values randomly selected within the range of 518-3066 μsec, with a minimum increment of 1 μsec, excluding PRI values selected in Test A			
2	1-5	150-230	23-29	60%	30
3	6-10	200-500	16-18	60%	30
4	11-20	200-500	12-16	60%	30
Aggregate (Radar Types 1-4)				80%	120

Note: Short Pulse Radar Type 0 should be used for the detection bandwidth test, channel move time, and channel closing time tests.

LONG PULSE RADAR TEST WAVEFORM

Radar Type	Pulse Width (μsec)	Chirp Width (MHz)	PRI (μsec)	Number of Pulses per Burst	Number of Bursts	Minimum Percentage of Successful Detection	Minimum Number of Trials
5	50-100	5-20	1000-2000	1-3	8-20	80%	30

FREQUENCY HOPPING RADAR TEST WAVEFORM

Radar Type	Pulse Width (μsec)	PRI (μsec)	Pulses per Hop	Hopping Rate (kHz)	Hopping Sequence Length (msec)	Minimum Percentage of Successful Detection	Minimum Number of Trials
6	1	333	9	0.333	300	70%	30

5.1.2.1 Test Setup

See 4.3 for test setup description for the radiated test. The photo of test setup please refer to ANNEX B.

5.1.2.2 Test Procedure

DFS MEASUREMENT SYSTEM:

A complete DFS Measurement System consists of two subsystems: (1) the Radar Signal Generating Subsystem and (2) the Traffic Monitoring Subsystem. The control PC is necessary for generating the Radar waveforms in Table 6, 7 and 8. The traffic monitoring subsystem is specified to the type of unit under test (UUT).

Conducted setup configuration of ADT DFS Measurement System

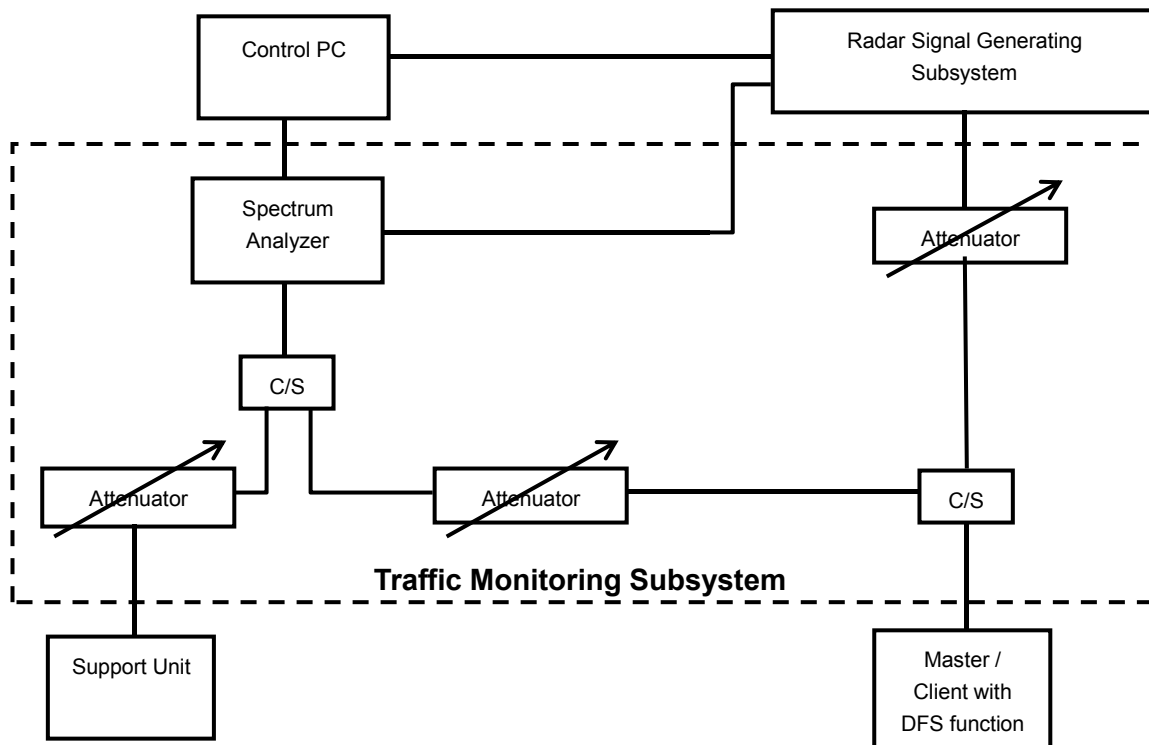

The test transmission will always be from the Master Device to the Client Device. While the Client device is set up to associate with the Master device and play the MPEG file (6 ½ Magic Hours) from Master device, the designated MPEG test file and instructions are located at: <http://ntiacsd.ntia.doc.gov/dfs/>.

CALIBRATION OF DFS DETECTION THRESHOLD LEVEL:

The measured channel is 5500 MHz in 20MHz Bandwidth and 5530MHz in 80MHz Bandwidth. The radar signal was the same as transmitted channels, and injected into the antenna port of AP (master) or Client Device with Radar Detection, measured the channel closing transmission time and channel move time. The Master antenna gain is 6.57dBi and required detection threshold is -54.43dBm (= -62 +1 +6.57)dBm. The calibrated conducted detection threshold level is set to -54.43 dBm.

Conducted setup configuration of Calibration of DFS Detection Threshold Level

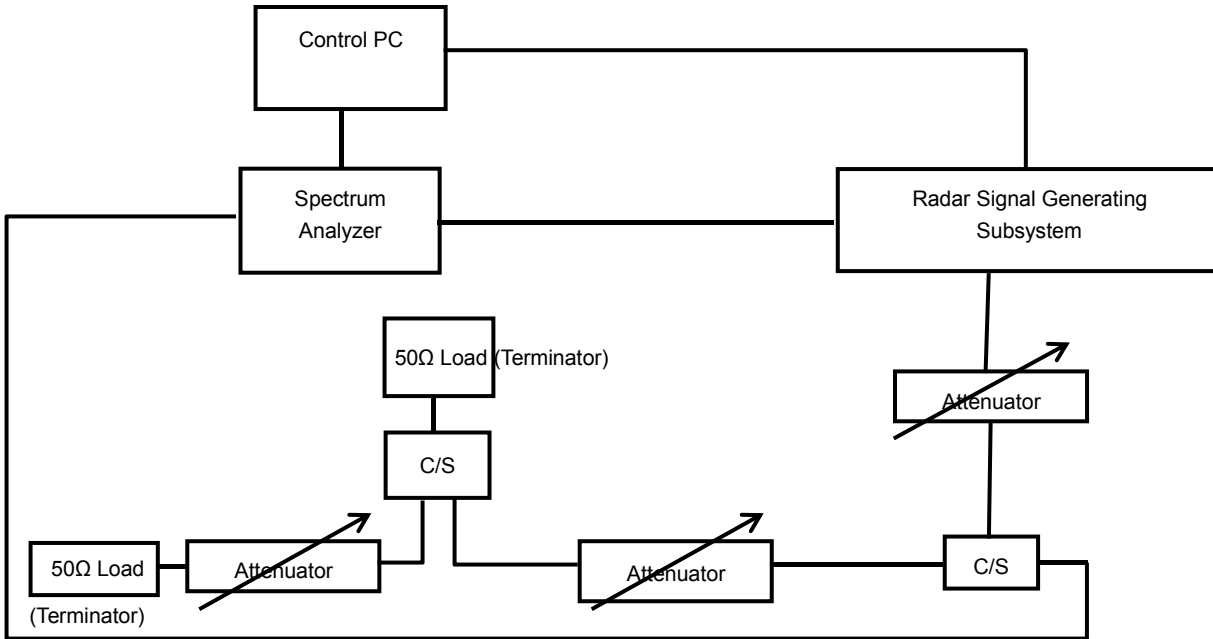

Radar Waveform Calibration Result

Radar Type 0 Calibration Plot (5290MHz)

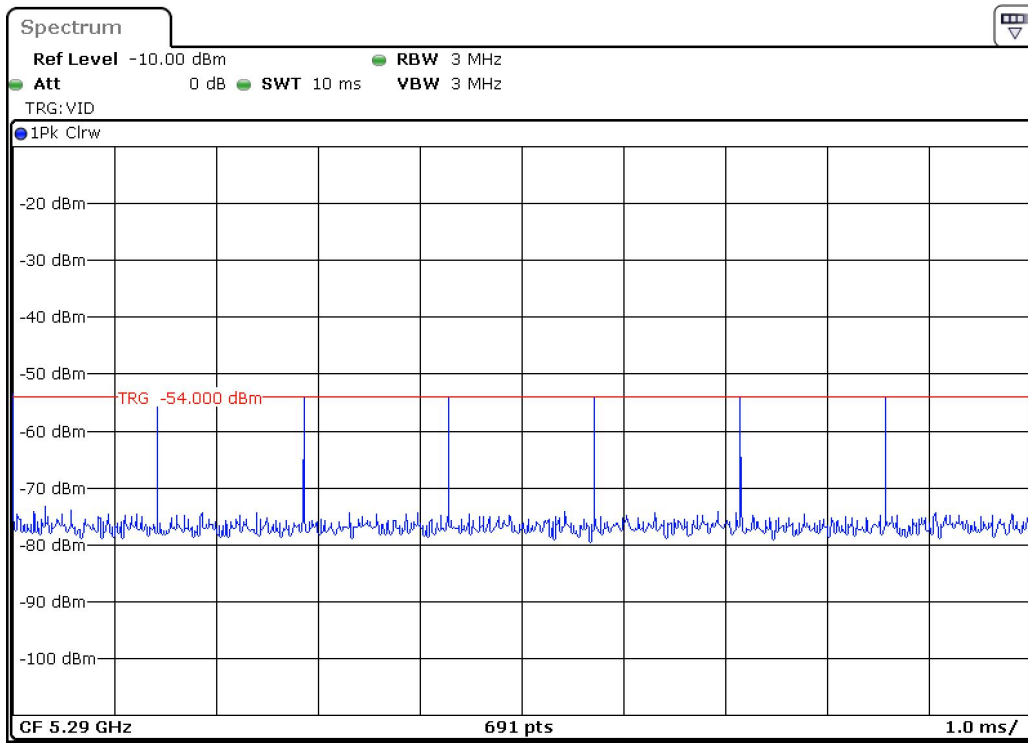

Trial ID	Radar type	Pulse width(us)	PRI(us)	Number of pulse
0	Type 0	1.0	1428	18
1	Type 0	1.0	1428	18
2	Type 0	1.0	1428	18
3	Type 0	1.0	1428	18
4	Type 0	1.0	1428	18
5	Type 0	1.0	1428	18
6	Type 0	1.0	1428	18
7	Type 0	1.0	1428	18
8	Type 0	1.0	1428	18
9	Type 0	1.0	1428	18
10	Type 0	1.0	1428	18
11	Type 0	1.0	1428	18
12	Type 0	1.0	1428	18
13	Type 0	1.0	1428	18
14	Type 0	1.0	1428	18
15	Type 0	1.0	1428	18
16	Type 0	1.0	1428	18
17	Type 0	1.0	1428	18
18	Type 0	1.0	1428	18
19	Type 0	1.0	1428	18
20	Type 0	1.0	1428	18
21	Type 0	1.0	1428	18
22	Type 0	1.0	1428	18

23	Type 0	1.0	1428	18
24	Type 0	1.0	1428	18
25	Type 0	1.0	1428	18
26	Type 0	1.0	1428	18
27	Type 0	1.0	1428	18
28	Type 0	1.0	1428	18
29	Type 0	1.0	1428	18

Radar Type 2 Calibration Plot (5290MHz)

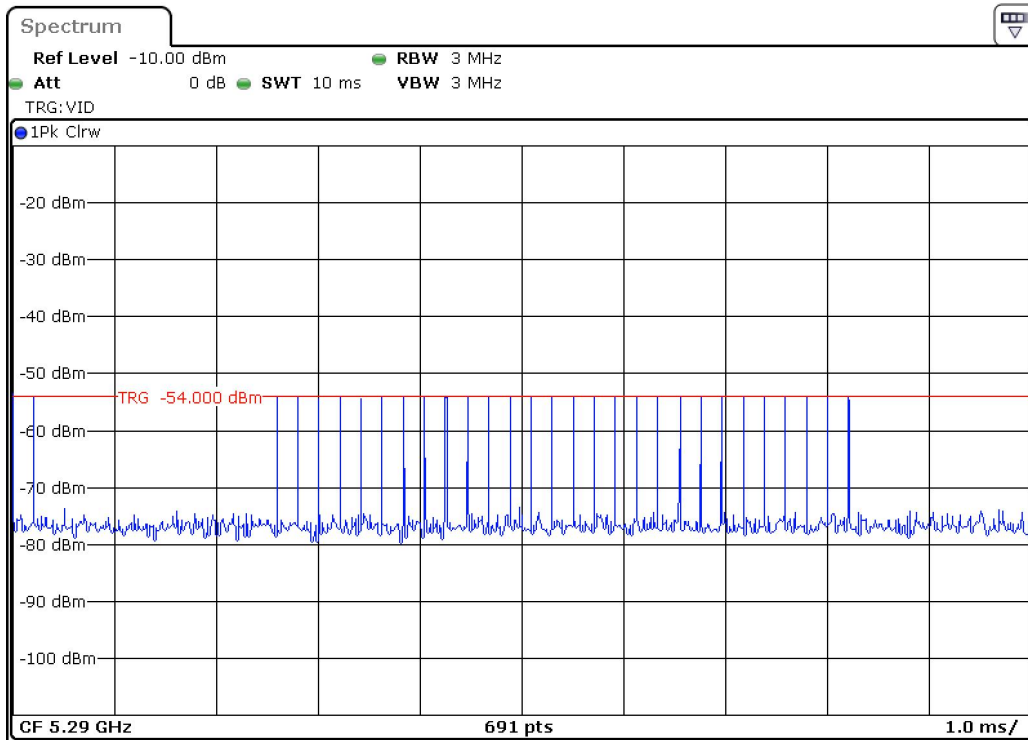

Trial ID	Radar type	Pulse width(us)	PRI(us)	Number of pulse
0	Type 2	2.4	161	27
1	Type 2	1.2	229	28
2	Type 2	3.3	180	23
3	Type 2	3.8	164	25
4	Type 2	4.4	185	24
5	Type 2	2.2	214	27
6	Type 2	4.5	157	28
7	Type 2	2.6	196	26
8	Type 2	2	216	24
9	Type 2	2.2	188	26
10	Type 2	2.8	191	29
11	Type 2	3.4	165	24
12	Type 2	1.6	164	27
13	Type 2	3.2	209	29
14	Type 2	1.4	213	29

15	Type 2	3.3	224	27
16	Type 2	4	217	25
17	Type 2	4.7	178	27
18	Type 2	3.9	183	26
19	Type 2	1.6	174	26
20	Type 2	2.3	182	24
21	Type 2	4.7	185	25
22	Type 2	2.2	199	23
23	Type 2	3.8	165	29
24	Type 2	4.3	227	28
25	Type 2	4.9	152	29
26	Type 2	4.2	220	29
27	Type 2	2.9	176	28
28	Type 2	4.6	159	25
29	Type 2	2	203	28

Radar Type 3 Calibration Plot (5290MHz)

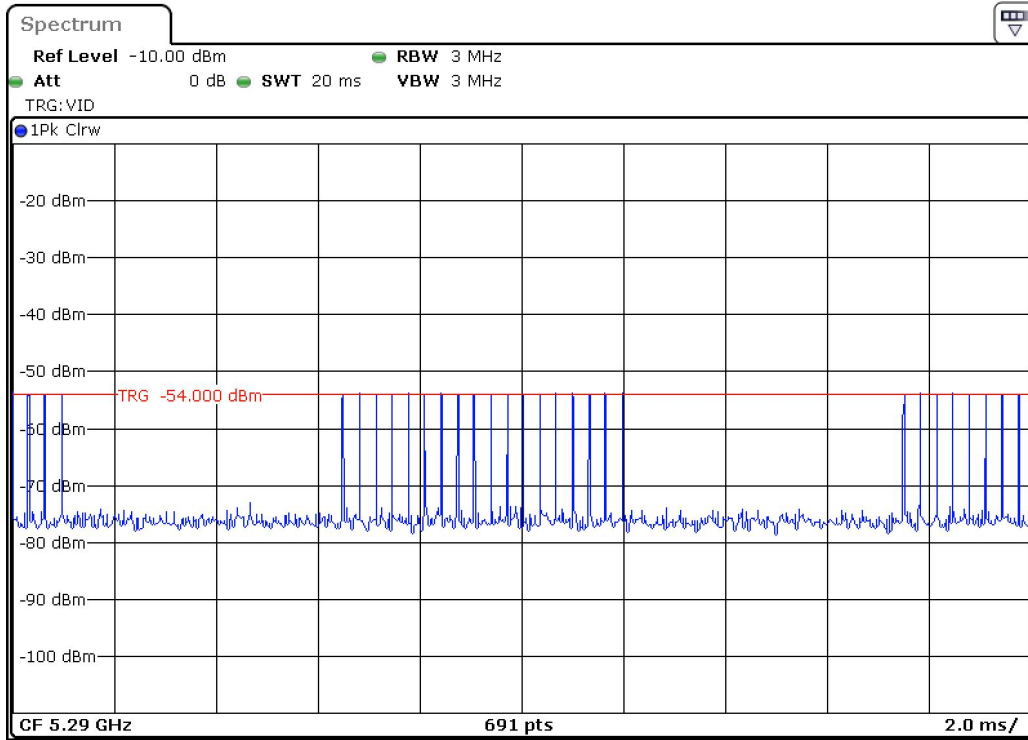

Trial ID	Radar type	Pulse width(us)	PRI(us)	Number of pulse
0	Type 3	9.2	455	17
1	Type 3	7.5	481	18
2	Type 3	8.7	373	16
3	Type 3	9.6	238	18
4	Type 3	8.1	218	18
5	Type 3	6.9	304	16
6	Type 3	7.6	274	18
7	Type 3	7.1	388	17
8	Type 3	6.3	242	17
9	Type 3	6.7	219	17
10	Type 3	8.7	478	17
11	Type 3	7.5	339	17
12	Type 3	7.3	327	16
13	Type 3	7.4	376	17
14	Type 3	9.6	358	16
15	Type 3	7.6	211	17
16	Type 3	9.9	283	17
17	Type 3	9	314	16
18	Type 3	6.2	477	18
19	Type 3	9.3	272	16
20	Type 3	8.1	288	17
21	Type 3	8	327	17
22	Type 3	9.9	255	18

23	Type 3	7.9	272	16
24	Type 3	8.9	494	17
25	Type 3	6.7	242	16
26	Type 3	7.9	262	17
27	Type 3	9.1	426	16
28	Type 3	9.6	346	18
29	Type 3	6.5	329	16

Radar Type 4 Calibration Plot (5290MHz)

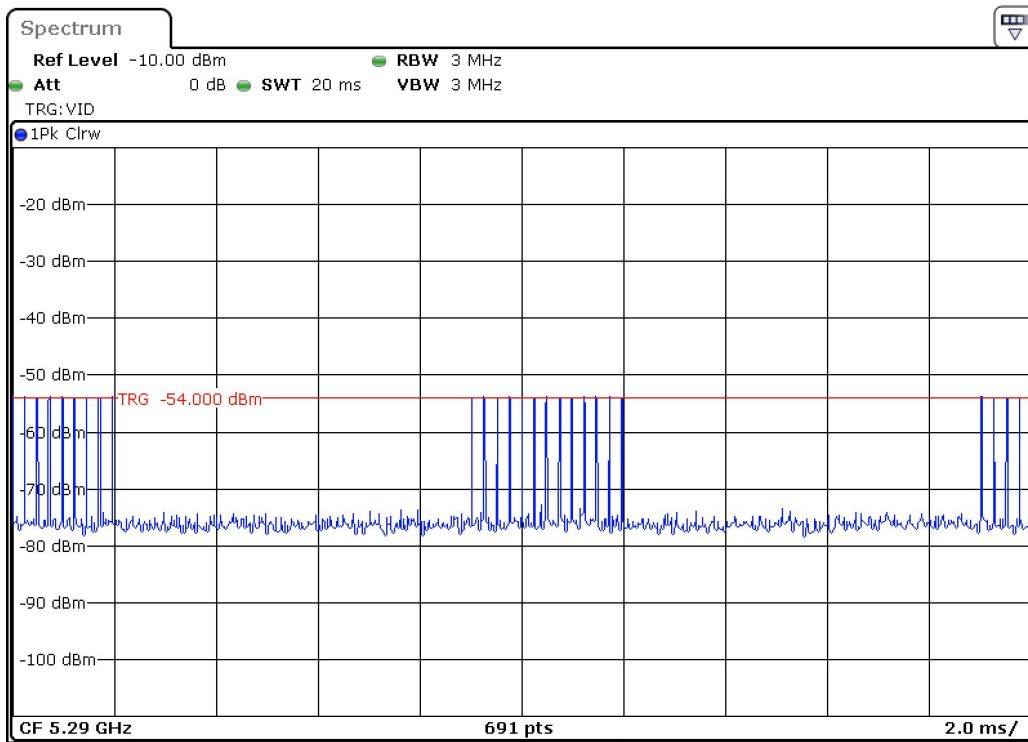

Trial ID	Radar type	Pulse width(us)	PRI(us)	Number of pulse
0	Type 4	20	296	14
1	Type 4	19.3	403	12
2	Type 4	13.4	326	12
3	Type 4	14.9	362	14
4	Type 4	18.7	480	13
5	Type 4	19.1	295	15
6	Type 4	11.2	278	16
7	Type 4	13.2	439	16
8	Type 4	19.5	294	16
9	Type 4	15.1	481	15
10	Type 4	14.2	221	13
11	Type 4	17.7	446	12
12	Type 4	16.5	264	16
13	Type 4	13.1	488	13
14	Type 4	11.5	241	13

15	Type 4	14.9	309	12
16	Type 4	17.6	310	13
17	Type 4	19.2	489	12
18	Type 4	11.7	369	14
19	Type 4	15.9	414	16
20	Type 4	11.1	245	12
21	Type 4	11.2	300	14
22	Type 4	15.1	300	16
23	Type 4	16.3	387	15
24	Type 4	16.4	246	12
25	Type 4	11.3	227	13
26	Type 4	17.8	349	12
27	Type 4	18.4	236	12
28	Type 4	16.4	482	12
29	Type 4	14.9	412	12

Radar Type 5 Calibration Plot (5290MHz)

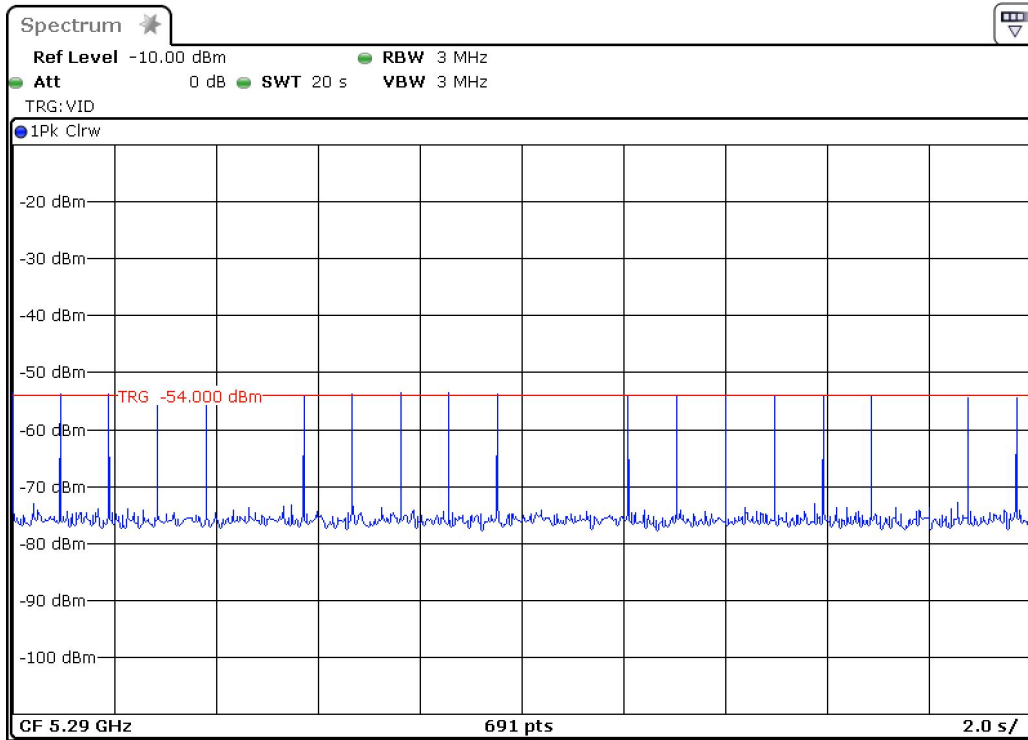

Trial ID	Radar type	Number of bursts	Burst period (S)	Waveform length (S)
0	Type 5	19	0.6315789	12.0000000
1	Type 5	14	0.8571429	12.0000000
2	Type 5	15	0.8000000	12.0000000
3	Type 5	9	1.3333333	12.0000000
4	Type 5	12	1.0000000	12.0000000
5	Type 5	19	0.6315789	12.0000000
6	Type 5	14	0.8571429	12.0000000
7	Type 5	20	0.6000000	12.0000000
8	Type 5	15	0.8000000	12.0000000
9	Type 5	8	1.5000000	12.0000000
10	Type 5	20	0.6000000	12.0000000
11	Type 5	16	0.7500000	12.0000000
12	Type 5	17	0.7058824	12.0000000
13	Type 5	13	0.9230769	12.0000000
14	Type 5	15	0.8000000	12.0000000
15	Type 5	18	0.6666667	12.0000000
16	Type 5	17	0.7058824	12.0000000
17	Type 5	12	1.0000000	12.0000000
18	Type 5	15	0.8000000	12.0000000
19	Type 5	14	0.8571429	12.0000000
20	Type 5	8	1.5000000	12.0000000
21	Type 5	20	0.6000000	12.0000000
22	Type 5	11	1.0909091	12.0000000
23	Type 5	15	0.8000000	12.0000000

24	Type 5	14	0.8571429	12.0000000
25	Type 5	8	1.5000000	12.0000000
26	Type 5	12	1.0000000	12.0000000
27	Type 5	18	0.6666667	12.0000000
28	Type 5	13	0.9230769	12.0000000
29	Type 5	17	0.7058824	12.0000000

Radar Type 6 Calibration Plot (5290MHz)

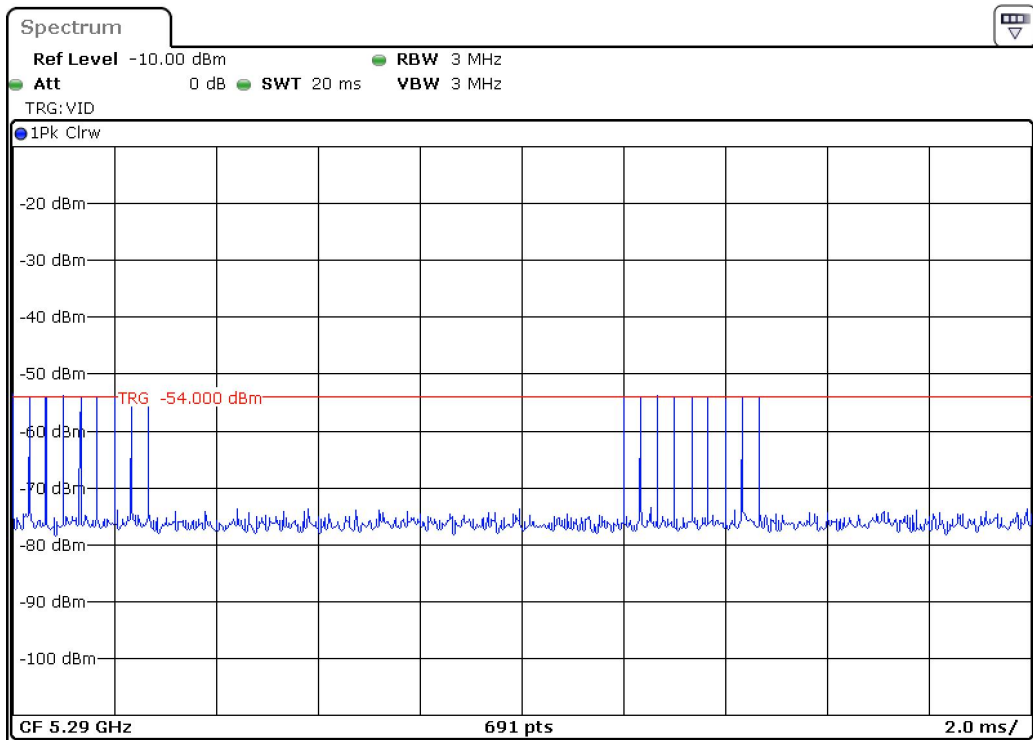

Trial ID	Radar type	Pulse width (us)	PRI (us)	Pulses per Hop	Hopping Rate (KHz)	Hopping sequence length (ms)	Visible frequency number
0	Type 6	1.0	333.3	9	0.3333	300	28
1	Type 6	1.0	333.3	9	0.3333	300	31
2	Type 6	1.0	333.3	9	0.3333	300	38
3	Type 6	1.0	333.3	9	0.3333	300	30
4	Type 6	1.0	333.3	9	0.3333	300	29
5	Type 6	1.0	333.3	9	0.3333	300	34
6	Type 6	1.0	333.3	9	0.3333	300	35
7	Type 6	1.0	333.3	9	0.3333	300	31
8	Type 6	1.0	333.3	9	0.3333	300	38
9	Type 6	1.0	333.3	9	0.3333	300	40
10	Type 6	1.0	333.3	9	0.3333	300	32
11	Type 6	1.0	333.3	9	0.3333	300	27
12	Type 6	1.0	333.3	9	0.3333	300	26
13	Type 6	1.0	333.3	9	0.3333	300	37

14	Type 6	1.0	333.3	9	0.3333	300	34
15	Type 6	1.0	333.3	9	0.3333	300	35
16	Type 6	1.0	333.3	9	0.3333	300	29
17	Type 6	1.0	333.3	9	0.3333	300	31
18	Type 6	1.0	333.3	9	0.3333	300	40
19	Type 6	1.0	333.3	9	0.3333	300	38
20	Type 6	1.0	333.3	9	0.3333	300	34
21	Type 6	1.0	333.3	9	0.3333	300	36
22	Type 6	1.0	333.3	9	0.3333	300	29
23	Type 6	1.0	333.3	9	0.3333	300	34
24	Type 6	1.0	333.3	9	0.3333	300	32
25	Type 6	1.0	333.3	9	0.3333	300	39
26	Type 6	1.0	333.3	9	0.3333	300	37
27	Type 6	1.0	333.3	9	0.3333	300	32
28	Type 6	1.0	333.3	9	0.3333	300	35
29	Type 6	1.0	333.3	9	0.3333	300	30

5.1.2.3 Test Result

Please refer to ANNEX A

ANNEX A TEST RESULT

A.1 CHANNEL CLOSING TRANSMISSION AND CHANNEL MOVE TIME

Result of DFS Channel Shutdown

Note: The radar test signals are injected into the Master Device.

Description	Operation Mode	Operation Channel	Value (s)	Limit
Channel Move Time	802.11ac (80 MHz)	58	0.520	10 s
Channel Closing Transmission Time	802.11ac (80 MHz)	58	0.038	200 milliseconds + an aggregate of 60 milliseconds over remaining 10 second period.
Channel Move Time	802.11ac (160 MHz)	114	0.627	10 s
Channel Closing Transmission Time	802.11ac (160 MHz)	114	0.040	200 milliseconds + an aggregate of 60 milliseconds over remaining 10 second period.
Test Verdict	Pass			

Note: The 802.11ac160 channel 50 test replace by the channel 58(80MHz).

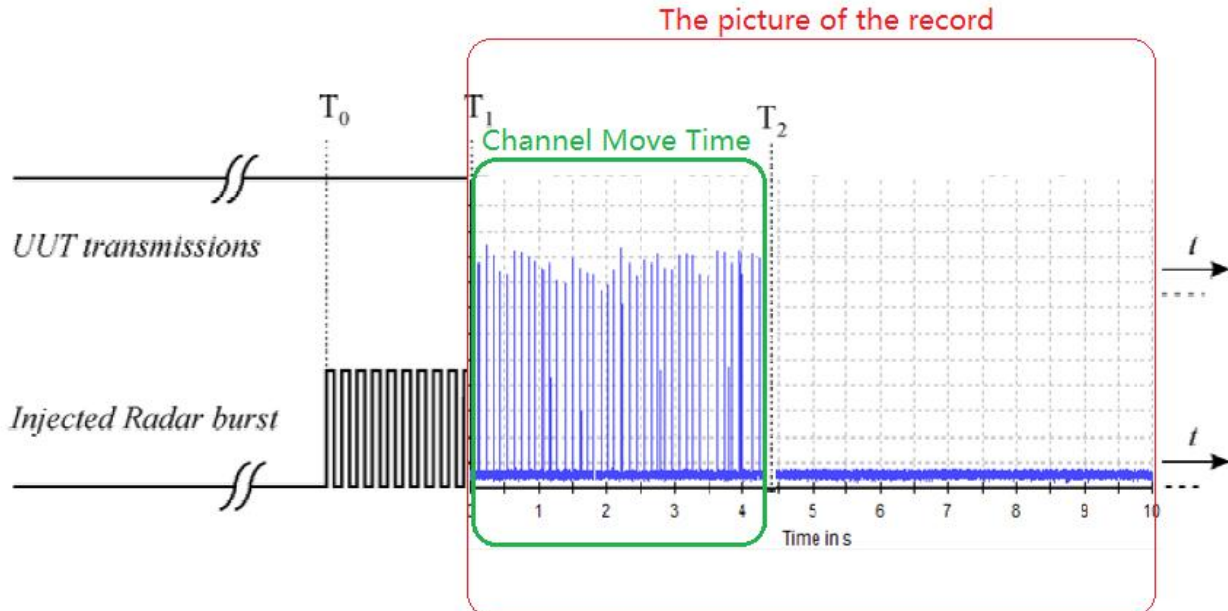

T0 denotes DFS test signal start generated on the channel.

T1 denotes the end of the radar burst.

T2 denotes the instant when the UUT has ceased all transmissions on the channel.

The time difference between T1 and T2 shall be measured. This value (*Channel Move Time*) shall be noted and compared with the limit.

The aggregate duration (*Channel Closing Transmission Time*) of all transmissions from the UUT on Chr during the *Channel Move Time* shall be compared to the limit.

DFS Test schematic graphic

802.11ac (80 MHz) Channel 58

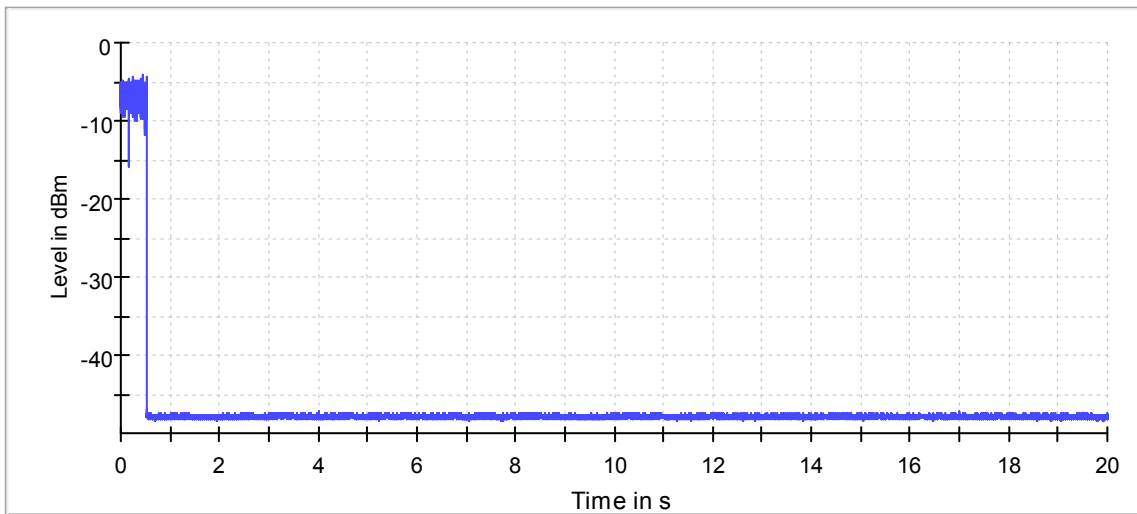

802.11ac (160 MHz) Channel 114

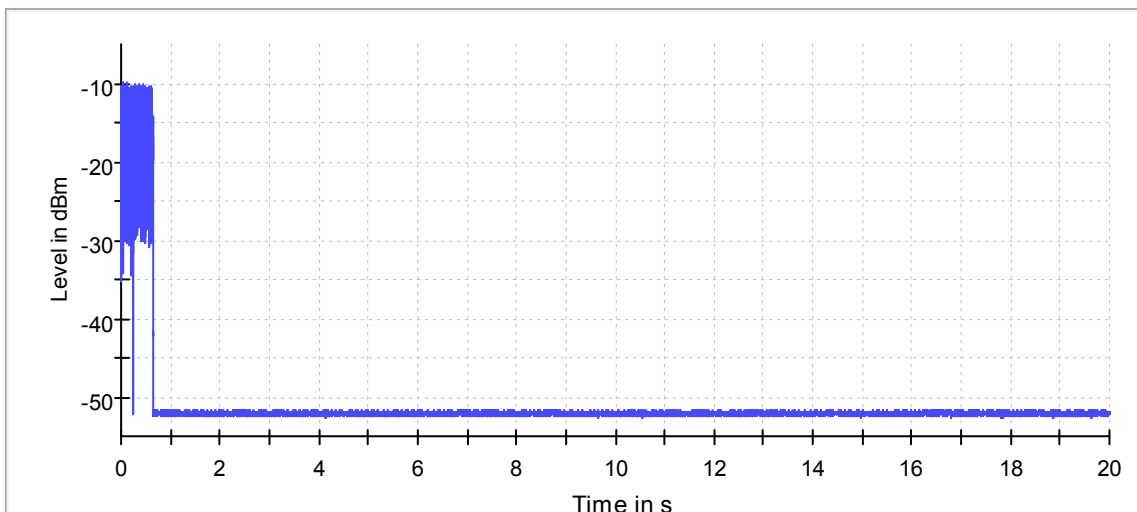

A.2 NON- OCCUPANCY PERIOD

Master was off.

During the 30 minutes observation time, The UUT did not make any transmissions in the DFS band after UUT power up.

802.11ac (80 MHz) Channel 58

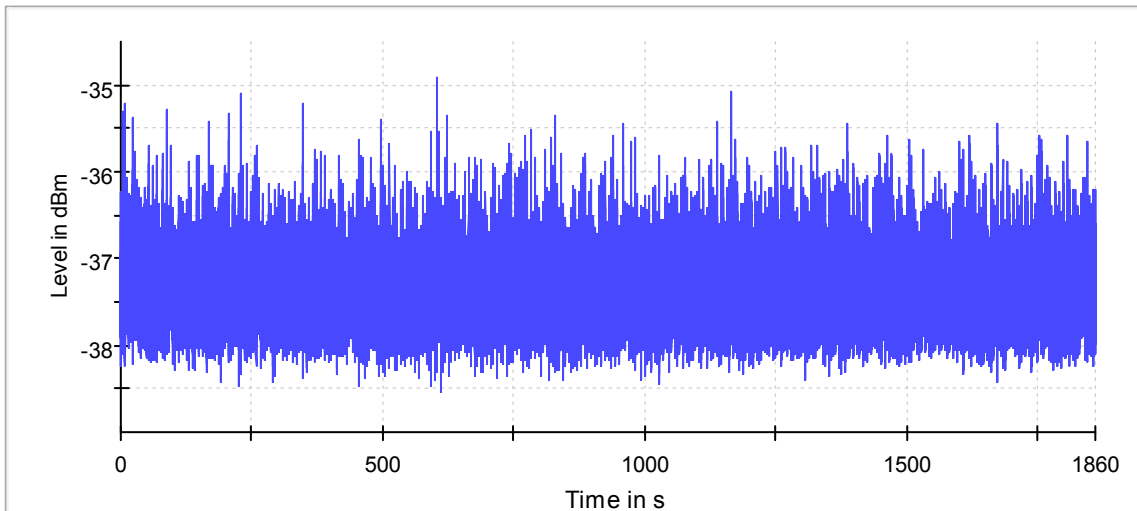

802.11ac (160 MHz) Channel 114

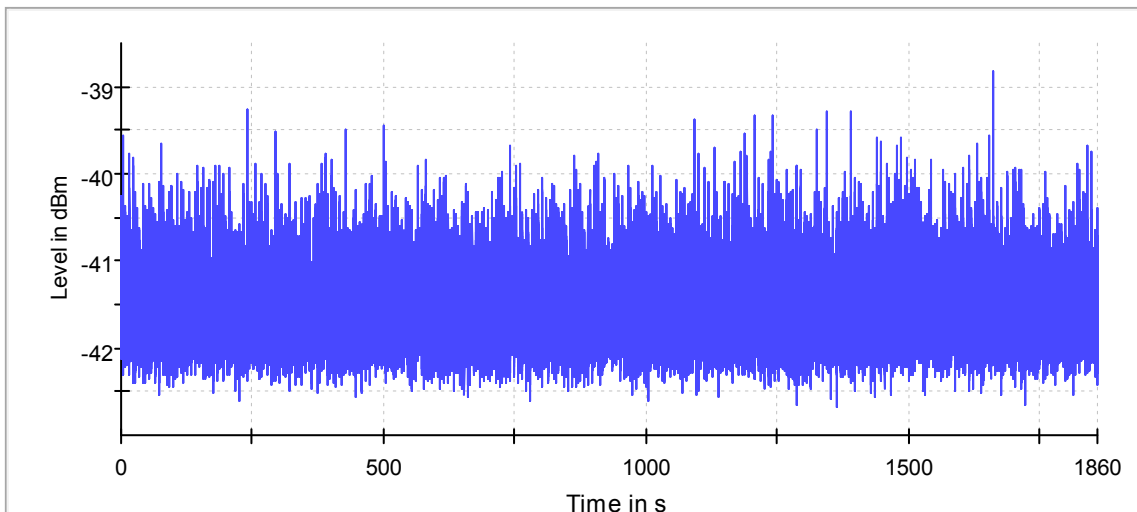

ANNEX B TEST SETUP PHOTOS

Please refer the document "BL-SZ1880358-AR.PDF".

ANNEX C EUT EXTERNAL PHOTOS

Please refer the document "BL-SZ1880358-AW.PDF".

ANNEX D EUT INTERNAL PHOTOS

Please refer the document "BL-SZ1880358-AI.PDF".

--END OF REPORT--