



中国认可  
国际互认  
检测  
TESTING  
CNAS L2264

# EMC TEST REPORT

**Applicant** Huawei Technologies Co., Ltd.  
**FCC ID** QISVKY-L09  
**Product** Smart Phone  
**Model** VKY-L09  
**Report No.** RHA1612-0111EMC01R1  
**Issue Date** January 24, 2017

TA Technology (Shanghai) Co., Ltd. tested the above equipment in accordance with the requirements in **FCC Code CFR47 Part15B (2015)/ ANSI C63.4 (2014)**. The test results show that the equipment tested is capable of demonstrating compliance with the requirements as documented in this report.

*Wei Liu*

*Guangchang Fan*

*Performed by: Wei Liu/ Manager*

*Approved by: Guangchang Fan/ Director*

## TA Technology (Shanghai) Co., Ltd.

No.145, Jintang Rd, Tangzhen Industry Park, Pudong Shanghai, China

TEL: +86-021-50791141/2/3

FAX: +86-021-50791141/2/3-8000

## Table of Contents

1	Test Laboratory.....	4
1.1	Notes of the Test Report.....	4
1.2	Test facility.....	4
1.3	Testing Location.....	5
2	General Description of Equipment under Test.....	6
2.1	Client Information.....	6
2.2	General information.....	6
2.3	Applied Standards.....	9
3	Test Case Results.....	10
3.1	Radiated Emission.....	10
3.2	Conducted Emission.....	17
4	Main Test Equipment.....	20
	ANNEX B: Product Change Description.....	21

### Summary of measurement results

Number	Test Case	Clause in FCC Rules	Conclusion
1	Radiated Emission	15.109, ANSI C63.4-2014	PASS
2	Conducted Emission	15.107, ANSI C63.4-2014	PASS
Test Date: December 3, 2016 and December 15, 2016			

VKY-L09 (RHA1612-0111EMC01R1) is a variant model of VKY-L29 (RHA1611-0091EMC01R1). Test values duplicated from Original for variant. The variant changed SIM card and model name, so there is no test for variant in this report. The detailed product change description please refers to the ANNEX B.

# 1 Test Laboratory

## 1.1 Notes of the Test Report

This report shall not be reproduced in full or partial, without the written approval of **TA technology (shanghai) co., Ltd.** The results documented in this report apply only to the tested sample, under the conditions and modes of operation as described herein .Measurement Uncertainties were not taken into account and are published for informational purposes only. This report is written to support regulatory compliance of the applicable standards stated above. This report must not be used by the client to claim product certification, approval, or endorsement by CNAS or any government agencies.

## 1.2 Test facility

### **CNAS (accreditation number: L2264)**

TA Technology (Shanghai) Co., Ltd. has obtained the accreditation of China National Accreditation Service for Conformity Assessment (CNAS).

### **FCC (recognition number is 428261)**

TA Technology (Shanghai) Co., Ltd. has been listed on the US Federal Communications Commission list of test facilities recognized to perform electromagnetic emissions measurements.

### **IC (recognition number is 8510A)**

TA Technology (Shanghai) Co., Ltd. has been listed by industry Canada to perform electromagnetic emission measurement.

### **VCCI (recognition number is C-4595, T-2154, R-4113, G-766)**

TA Technology (Shanghai) Co., Ltd. has been listed by industry Japan to perform electromagnetic emission measurement.

### **A2LA (Certificate Number: 3857.01)**

TA Technology (Shanghai) Co., Ltd. has been listed by American Association for Laboratory Accreditation to perform electromagnetic emission measurement.

### 1.3 Testing Location

Company: TA Technology (Shanghai) Co., Ltd.  
Address: No.145, Jintang Rd, Tangzhen Industry Park, Pudong Shanghai, China  
City: Shanghai  
Post code: 201201  
Country: P. R. China  
Contact: Xu Kai  
Telephone: +86-021-50791141/2/3  
Fax: +86-021-50791141/2/3-8000  
Website: <http://www.ta-shanghai.com>  
E-mail: [xukai@ta-shanghai.com](mailto:xukai@ta-shanghai.com)

## 2 General Description of Equipment under Test

### 2.1 Client Information

<b>Applicant</b>	Huawei Technologies Co., Ltd.
<b>Applicant address</b>	Administration Building, Headquarters of Huawei Technologies Co., Ltd., Bantian, Longgang District, Shenzhen, 518129, P.R.China.
<b>Manufacturer</b>	Huawei Technologies Co., Ltd.
<b>Manufacturer address</b>	Administration Building, Headquarters of Huawei Technologies Co., Ltd., Bantian, Longgang District, Shenzhen, 518129, P.R.China.

### 2.2 General information

EUT Description	
Device Type:	Portable Device
Product Name:	Smart Phone
Model Number:	VKY-L09
HW Version:	HL1AVICKYM
SW Version:	D189-L09C432B083
IMEI:	862940030039030
Antenna Type:	Internal Antenna
Used Host Product:	PC Manufacturer: lenovo Model: Thinkpad T540p (SN : SL10E37685)
Test Mode:	Transfer Data Mode
EUT Accessory	
Adapter 1	Manufacturer: DONGGUAN PHITEK ELECTRONICS CO., LTD Model: HW-050450U00 Input power: 100V-240V~50/60Hz, 0.75A Output power: 5Vdc, 2A or 5Vdc, 4.5A or 4.5Vdc, 5A
Adapter 2	Manufacturer: SHENZHEN HUNTKEY ELECTRONIC CO., LTD. Model: HW-050450U00 Input power: 100V-240V~50/60Hz, 0.75A Output power: 5Vdc, 2A or 5Vdc, 4.5A or 4.5Vdc, 5A
Adapter 3	Manufacturer: Salcomp (Shenzhen) Co., Ltd

	<p>Model: HW-050450U00  Input power: 100V-240V~50/60Hz, 0.75A  Output power: 5Vdc, 2A or 5Vdc, 4.5A or 4.5Vdc, 5A</p>
Adapter 4	<p>Manufacturer: DONGGUAN PHITEK ELECTRONICS CO., LTD  Model: HW-050450B00  Input power: 100V-240V~50/60Hz, 0.75A  Output power: 5Vdc, 2A or 5Vdc, 4.5A or 4.5Vdc, 5A</p>
Adapter 5	<p>Manufacturer: SHENZHEN HUNTKEY ELECTRONIC CO., LTD.  Model: HW-050450B00  Input power: 100V-240V~50/60Hz, 0.75A  Output power: 5Vdc, 2A or 5Vdc, 4.5A or 4.5Vdc, 5A</p>
Adapter 6	<p>Manufacturer: Salcomp (Shenzhen) Co., Ltd  Model: HW-050450B00  Input power: 100V-240V~50/60Hz, 0.75A  Output power: 5Vdc, 2A or 5Vdc, 4.5A or 4.5Vdc, 5A</p>
Adapter 7	<p>Manufacturer: DONGGUAN PHITEK ELECTRONICS CO., LTD  Model: HW-050450E00  Input power: 100V-240V~50/60Hz, 0.75A  Output power: 5Vdc, 2A or 5Vdc, 4.5A or 4.5Vdc, 5A</p>
Adapter 8	<p>Manufacturer: SHENZHEN HUNTKEY ELECTRONIC CO., LTD.  Model: HW-050450E00  Input power: 100V-240V~50/60Hz, 0.75A  Output power: 5Vdc, 2A or 5Vdc, 4.5A or 4.5Vdc, 5A</p>
Adapter 9	<p>Manufacturer: Salcomp (Shenzhen) Co., Ltd  Model: HW-050450E00  Input power: 100V-240V~50/60Hz, 0.75A  Output power: 5Vdc, 2A or 5Vdc, 4.5A or 4.5Vdc, 5A</p>
Adapter 10	<p>Manufacturer: DONGGUAN PHITEK ELECTRONICS CO., LTD  Model: HW-050450A00  Input power: 100V-240V~50/60Hz, 0.75A  Output power: 5Vdc, 2A or 5Vdc, 4.5A or 4.5Vdc, 5A</p>
Adapter 11	<p>Manufacturer: SHENZHEN HUNTKEY ELECTRONIC CO., LTD.  Model: HW-050450A00  Input power: 100V-240V~50/60Hz, 0.75A  Output power: 5Vdc, 2A or 5Vdc, 4.5A or 4.5Vdc, 5A</p>
Adapter 12	<p>Manufacturer: Salcomp (Shenzhen) Co., Ltd  Model: HW-050450A00  Input power: 100V-240V~50/60Hz, 0.75A  Output power: 5Vdc, 2A or 5Vdc, 4.5A or 4.5Vdc, 5A</p>
Battery 1	<p>Manufacturer: Sunwoda Electronic Co., LTD  Model: HB386589ECW  Power Rating: DC 3.82V, 3650mAh, Li-ion</p>
Battery 2	<p>Manufacturer: SCUD (FUJIAN) Electronics Co., Ltd  Model: HB386589ECW</p>

	Power Rating: DC 3.82V, 3650mAh, Li-ion
Battery 3	Manufacturer: Desay Battery Co., Ltd. Model: HB386589ECW Power Rating: DC 3.82V, 3650mAh, Li-ion
Earphone 1	Manufacturer: JIANGXI LIANCHUANG HONGSHENG ELECTRONIC CO., LTD Model: MEMD1632B580C00
Earphone 2	Manufacturer: BOLUO COUNTY QUANCHENG ELECTRONIC CO., LTD Model: 1311-3291-3.5mm-229
Earphone 3	Manufacturer: Goer Tek Inc Model: NA12
Earphone 4	Manufacturer: MERRY ELECTRONICS (SHENZHEN) CO., LTD. Model: EMC309-001
USB Cable 1	Manufacturer: LUXSHARE-ICT Co., Ltd. Model: L99UC018-CS-H
USB Cable 2	Manufacturer: Chang Shu Honglin Technology Co.,Ltd. Model: 130-27309
Remark: The information of the EUT is declared by the manufacturer. Please refer to the specifications or user manual for details.	

## **2.3 Applied Standards**

According to the specifications of the manufacturer, it must comply with the requirements of the following standards:

### **Test standards**

**FCC Code CFR47 Part15B (2015)**

**ANSI C63.4 (2014)**

### 3 Test Case Results

#### 3.1 Radiated Emission

##### Ambient condition

Temperature	Relative humidity	Pressure
24°C~26°C	45%~50%	102.5kPa

##### Methods of Measurement

The EUT is placed on a non-metallic table 0.8m above the horizontal metal reference ground plane. The distance between EUT and receive antenna should be 3 meters. During the test, the EUT was operating in its typical mode. The test method is according to ANSI C63.4-2014. Sweep the whole frequency band through the range from 30MHz to the 5th harmonic of the carrier. During the test, the height of receive antenna shall be moved from 1 to 4 meters, and the antenna shall be performed under horizontal and vertical polarization. The turn table shall be rotated from 0 to 360 degrees for detecting the maximum of radiated signal level.

The data of cable loss and antenna factor has been calibrated in full testing frequency range before the testing. During the test, the EUT is worked at maximum output power.

Set the spectrum analyzer in the following:

Below 1GHz:

RBW=100 kHz / VBW=300 kHz / Sweep=AUTO

Above 1GHz:

(a) PEAK: RBW=1MHz VBW=3MHz/ Sweep=AUTO

(b) AVERAGE: RBW=1MHz / VBW=3MHz / Sweep=AUTO

During the test, EUT is connected to a laptop via a USB cable in the case of Transfer Data mode. The EUT is used as the peripheral equipment of the PC. The data is transferred from EUT to PC; PC is connected to server via a long LAN cable.

**Test Setup**

**Below 1GHz**

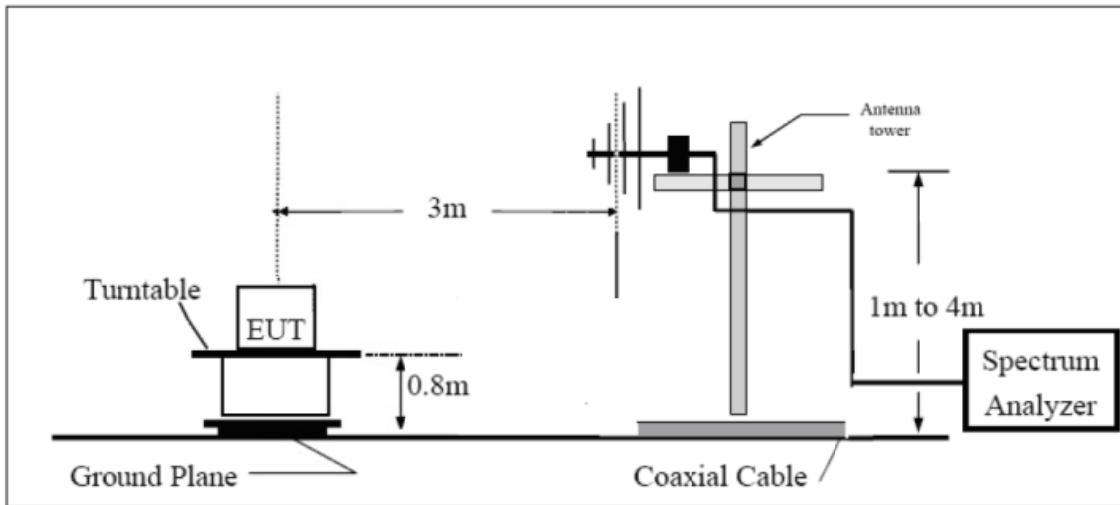

**Above 1GHz**

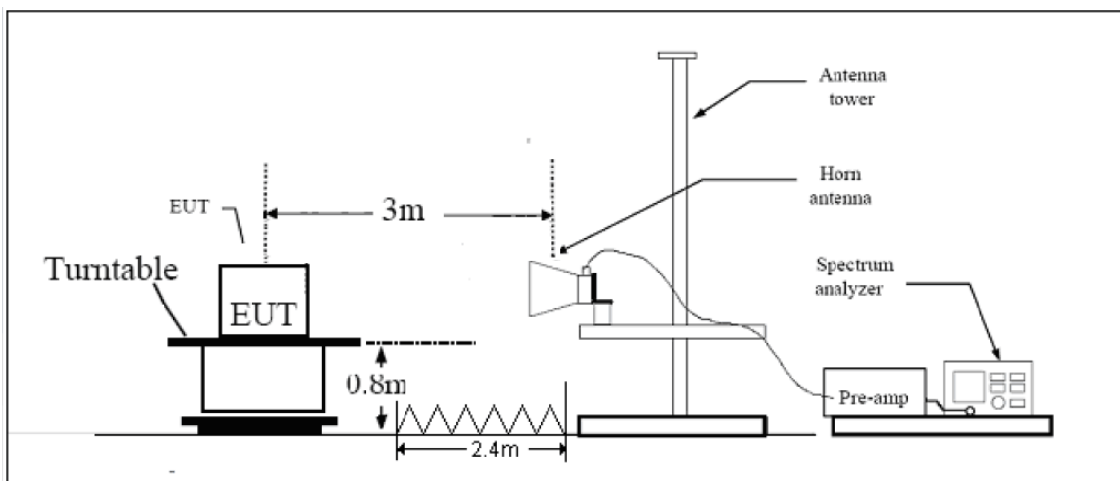

Note: Area side:2.4mX3.6m

Antenna Tower meets ANSI C63.4 requirements for measurements above 1 GHz by keeping the antenna aimed at the EUT during the antenna's ascent/ descent along the antenna mast.

**Limits**

Frequency (MHz)	Field Strength (dB $\mu$ V/m)	Detector
30 -88	40.0	Quasi-peak
88-216	43.5	Quasi-peak
216 – 960	46.0	Quasi-peak
960-1000	54.0	Quasi-peak
1000-5 <sup>th</sup> harmonic of the highest frequency or 40GHz, which is lower	54 74	Average Peak

**Measurement Uncertainty**

The assessed measurement uncertainty to ensure 95% confidence level for the normal distribution is with the coverage factor  $k = 1.96$ .  $U = 3.92$  dB.

**Test Results**

The following graphs display the maximum values of horizontal and vertical by software.  
 For above 1GHz, Blue trace uses the peak detection, Green trace uses the average detection.

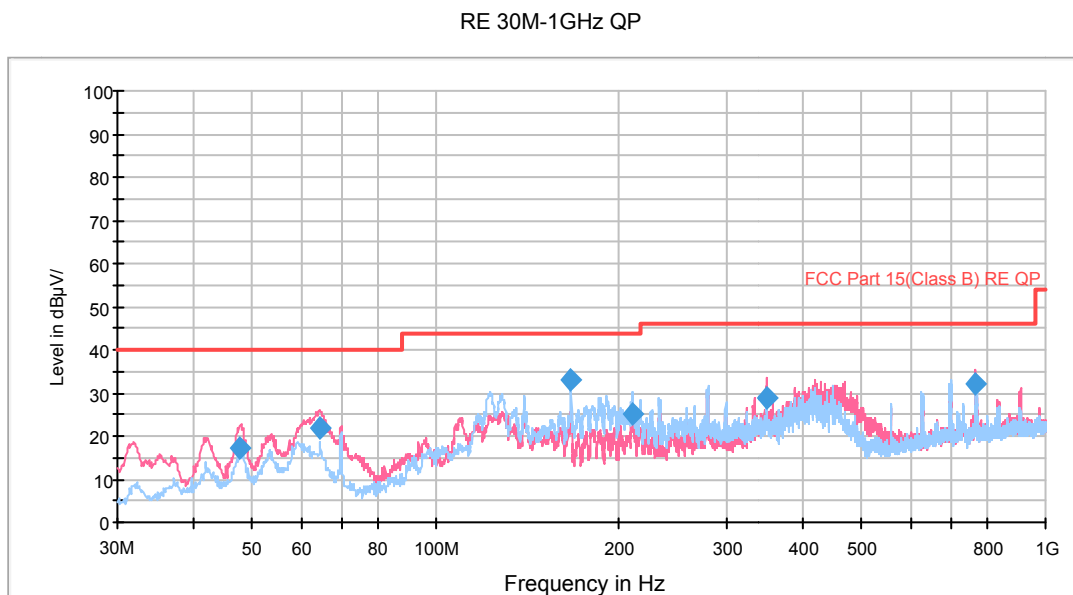

Radiated Emission from 30MHz to 1GHz

Frequency (MHz)	Quasi-Peak (dBuV/m)	Reading value (dBuV/m)	Height (cm)	Polarization	Azimuth (deg)	Correct Factor (dB)	Margin (dB)	Limit (dBuV/m)
47.704190	17.2	37.4	122.0	V	275.0	-20.2	22.8	40.0
64.474535	21.9	45.6	102.0	V	350.0	-23.7	18.1	40.0
166.026447	33.2	61.5	176.0	H	46.0	-28.3	10.3	43.5
209.890000	25.2	51.1	176.0	H	245.0	-25.9	18.3	43.5
349.823000	28.8	51.3	127.0	V	21.0	-22.5	17.2	46.0
766.718000	32.1	47.1	102.0	V	34.0	-15.0	13.9	46.0

- Remark:**
1. Quasi-Peak = Reading value + Correction factor
  2. Correction Factor = Antenna factor+ Insertion loss(cable loss+amplifier gain)
  3. Margin = Limit – Quasi-Peak

RE 1G-3GHz PK+AV

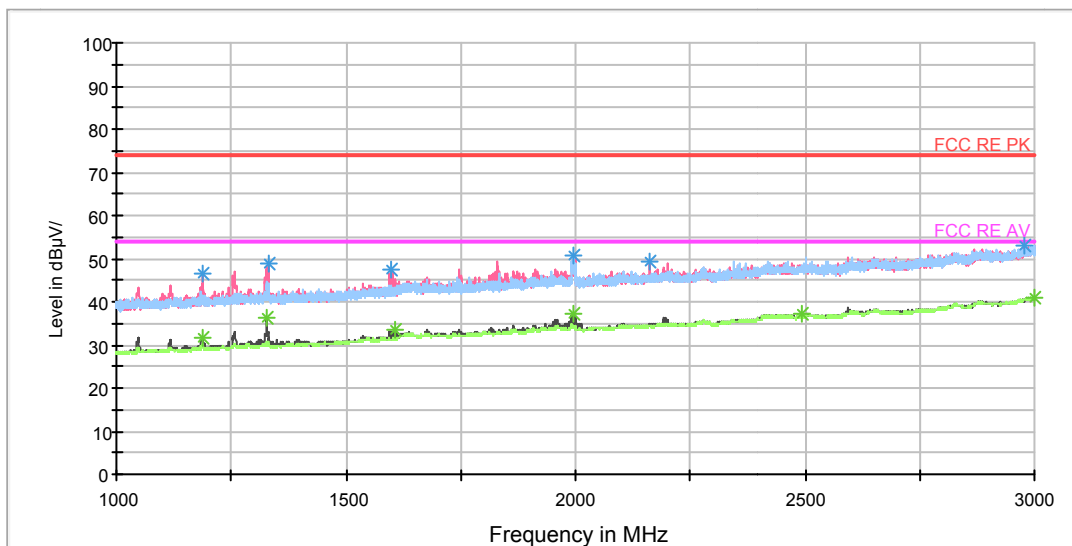

Radiated Emission from 1GHz to 3GHz

Frequency (MHz)	Peak (dBuV/m)	Reading value (dBuV/m)	Height (cm)	Polarization	Azimuth (deg)	Correct Factor (dB)	Margin (dB)	Limit (dBuV/m)
1186.750000	46.5	54.6	103.0	V	51.0	-8.1	27.5	74
1331.250000	48.7	56.1	103.0	V	0.0	-7.4	25.3	74
1598.250000	47.5	53.9	103.0	V	0.0	-6.4	26.5	74
1996.250000	50.7	54.0	202.0	H	308.0	-3.3	23.3	74
2160.250000	49.2	51.4	202.0	V	240.0	-2.2	24.8	74
2978.250000	53.2	55.4	103.0	V	0.0	2.2	20.8	74

Frequency (MHz)	Average (dBuV/m)	Reading value (dBuV/m)	Height (cm)	Polarization	Azimuth (deg)	Correct Factor (dB)	Margin (dB)	Limit (dBuV/m)
1186.750000	31.8	39.9	103.0	V	51.0	-8.1	22.2	54
1328.750000	36.3	43.7	103.0	V	0.0	-7.4	17.7	54
1607.750000	33.4	39.4	103.0	V	25.0	-6.0	20.6	54
1995.000000	37.0	40.2	103.0	V	0.0	-3.2	17.0	54
2492.750000	37.0	37.2	103.0	V	0.0	0.2	17.0	54
2998.000000	41.1	43.4	202.0	V	55.0	2.3	12.9	54

RE 3-18GHz PK+AV

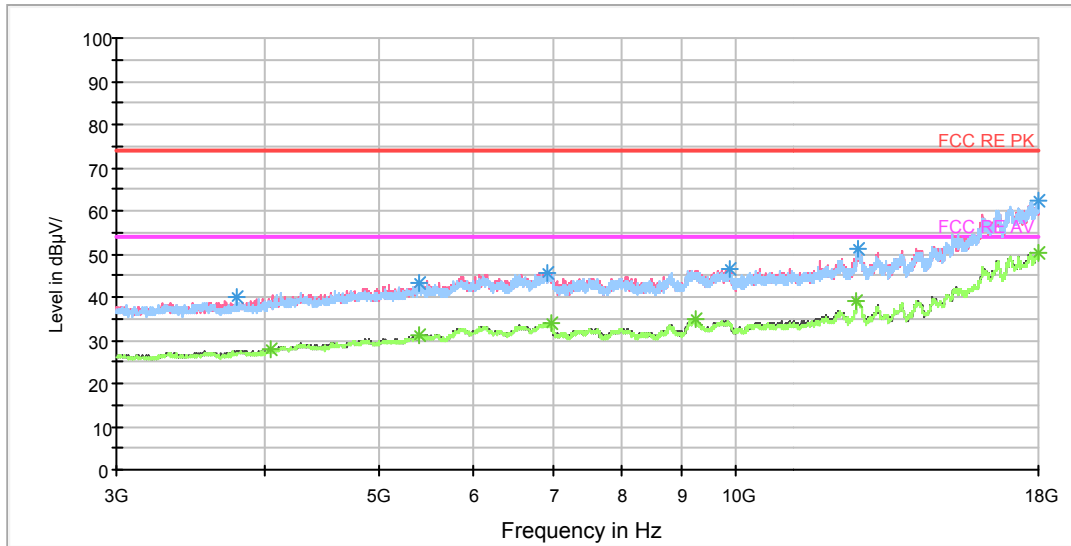

Radiated Emission from 3GHz to 18GHz

Frequency (MHz)	Peak (dBuV/m)	Reading value (dBuV/m)	Height (cm)	Polarization	Azimuth (deg)	Correct Factor (dB)	Margin (dB)	Limit (dBuV/m)
3783.750000	40.0	41.8	202.0	H	108.0	-1.8	34.0	74
5407.500000	43.3	45.9	202.0	H	51.0	2.6	30.7	74
6933.750000	45.6	51.8	202.0	V	0.0	6.2	28.4	74
9875.625000	46.7	57.0	202.0	V	0.0	10.3	27.3	74
12682.500000	51.1	65.3	202.0	H	0.0	14.2	22.9	74
17996.250000	62.4	87.8	103.0	H	8.0	25.4	11.6	74

Frequency (MHz)	Average (dBuV/m)	Reading value (dBuV/m)	Height (cm)	Polarization	Azimuth (deg)	Correct Factor (dB)	Margin (dB)	Limit (dBuV/m)
4042.500000	27.9	28.9	202.0	V	83.0	-1.0	26.1	54
5409.375000	31.4	34.0	202.0	V	0.0	2.6	22.6	54
6991.875000	34.0	40.5	202.0	V	2.0	6.5	20.0	54
9240.000000	34.9	44.8	202.0	V	110.0	9.9	19.1	54
12639.375000	39.3	53.8	103.0	V	140.0	14.5	14.7	54
18000.000000	50.1	75.6	202.0	H	271.0	25.5	3.9	54

RE 18-26.5GHz PK+AV

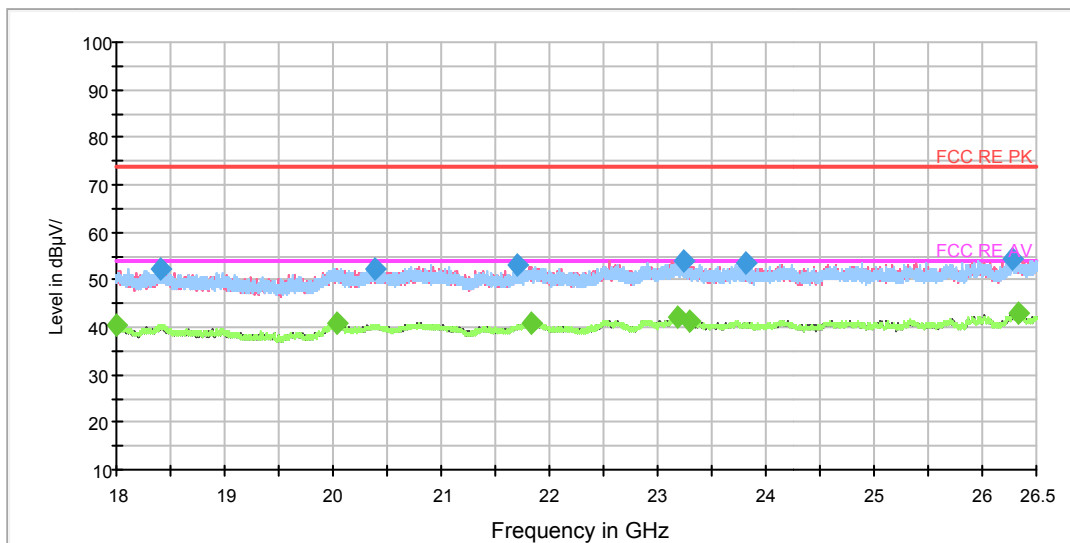

Radiated Emission from 18GHz to 26.5GHz

Frequency (MHz)	Peak (dBuV/m)	Reading value (dBuV/m)	Polarization	Azimuth (deg)	Correct Factor (dB)	Margin (dB)	Limit (dBuV/m)
18400.031250	52.3	55.8	H	0.0	-3.5	21.7	74
20397.000000	52.3	58.4	H	66.0	-6.1	21.7	74
21708.125000	53.1	61.1	V	152.0	-8.0	20.9	74
23245.562500	54.0	60.0	V	134.0	-6.0	20.0	74
23816.125000	53.7	59.6	H	131.0	-5.9	20.3	74
26284.843750	54.3	59.7	V	180.0	-5.4	19.7	74

Frequency (MHz)	Average (dBuV/m)	Reading value (dBuV/m)	Polarization	Azimuth (deg)	Correct Factor (dB)	Margin (dB)	Limit (dBuV/m)
18003.718750	40.4	42.2	V	180.0	-1.8	13.6	54
20033.625000	40.8	46.5	V	180.0	-5.7	13.2	54
21830.312500	41.0	49.0	H	39.0	-8.0	13.0	54
23178.093750	42.2	48.3	V	30.0	-6.1	11.8	54
23302.406250	41.4	47.4	V	161.0	-6.0	12.6	54
26332.656250	42.8	48.2	V	125.0	-5.4	11.2	54

### 3.2 Conducted Emission

#### Ambient condition

Temperature	Relative humidity	Pressure
24°C ~26°C	50%~55%	102.5kPa

#### Methods of Measurement

The EUT is placed on a non-metallic table of 80cm height above the horizontal metal reference ground plane. During the test, the EUT was operating in its typical mode. The test method is according to ANSI C63.4-2014. Connect the AC power line of the EUT to the L.I.S.N. Use EMI receiver to detect the average and Quasi-peak value. RBW is set to 9 kHz, VBW is set to 30kHz. The measurement result should include both L line and N line.

During the test, EUT is connected to a laptop via a USB cable in the case of Transfer Data mode. The EUT is used as the peripheral equipment of the PC. The data is transferred from EUT to PC; PC is connected to server via a long LAN cable.

#### Test Setup

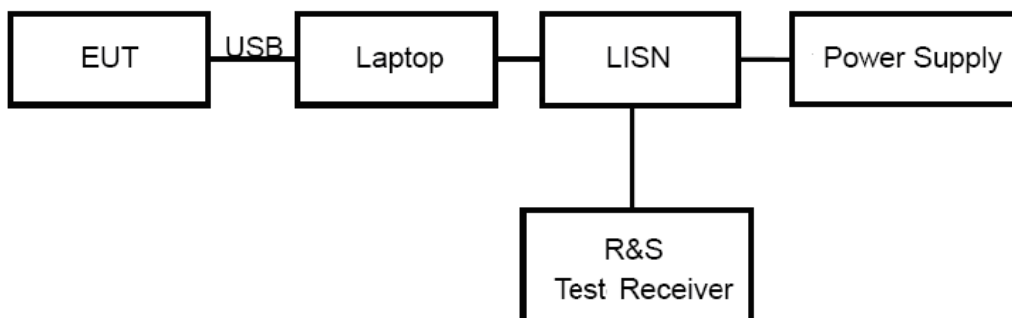

Note: Power Supply is AC Power source and it is used to change the voltage 120V/60Hz.

#### Limits

Frequency (MHz)	Conducted Limits(dBμV)	
	Quasi-peak	Average
0.15 - 0.5	66 to 56 *	56 to 46 *
0.5 - 5	56	46
5 - 30	60	50

\*: Decreases with the logarithm of the frequency.

#### Measurement Uncertainty

The assessed measurement uncertainty to ensure 95% confidence level for the normal distribution is with the coverage factor  $k = 1.96$ .  $U = 2.69$  dB.

**Test Results**

Following plots, Blue trace uses the peak detection; Green trace uses the average detection.

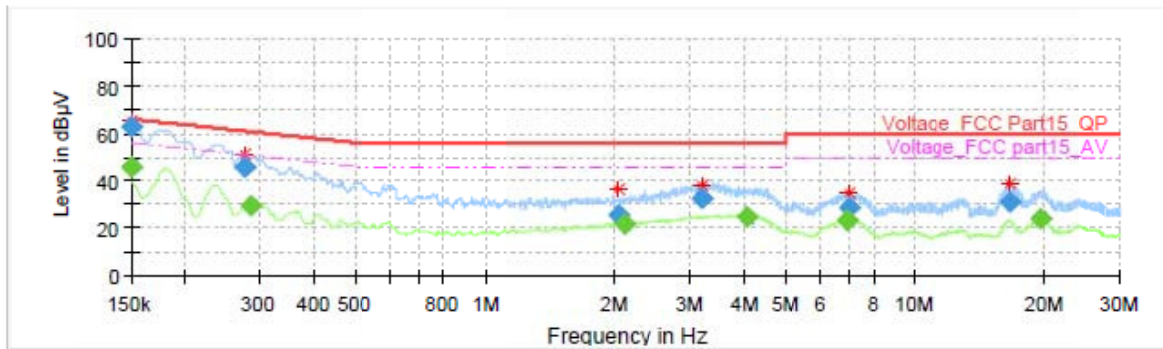

**Final Result**

Frequency (MHz)	QuasiPeak (dBµV)	Average (dBµV)	Limit (dBµV)	Margin (dB)	Meas. Time (ms)	Bandwidth (kHz)	Line	Filter	Corr. (dB)
0.150000	---	45.94	56.00	10.06	1000.0	9.000	L1	ON	19.1
0.150000	62.60	---	66.00	3.40	1000.0	9.000	L1	ON	19.1
0.276000	45.73	---	60.94	15.21	1000.0	9.000	L1	ON	19.2
0.287250	---	29.81	50.60	20.80	1000.0	9.000	L1	ON	19.2
2.042250	25.87	---	56.00	30.13	1000.0	9.000	L1	ON	19.1
2.114250	---	21.40	46.00	24.60	1000.0	9.000	L1	ON	19.1
3.187500	32.65	---	56.00	23.35	1000.0	9.000	L1	ON	19.1
4.044750	---	24.93	46.00	21.07	1000.0	9.000	L1	ON	19.1
6.951750	---	23.62	50.00	26.38	1000.0	9.000	L1	ON	19.2
6.983250	28.65	---	60.00	31.35	1000.0	9.000	L1	ON	19.2
16.689750	31.26	---	60.00	28.74	1000.0	9.000	L1	ON	19.5
19.497750	---	24.40	50.00	25.60	1000.0	9.000	L1	ON	19.6

L line

Conducted Emission from 150 KHz to 30 MHz

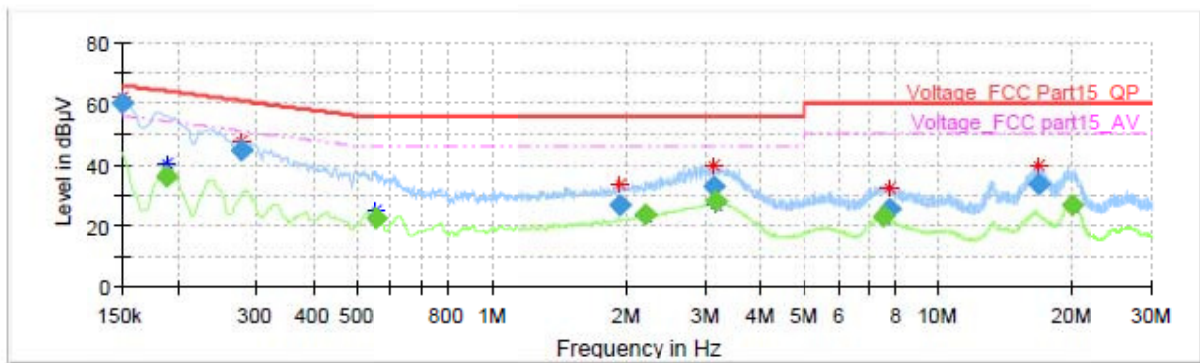

### Final Result

Frequency (MHz)	QuasiPeak (dBµV)	Average (dBµV)	Limit (dBµV)	Margin (dB)	Meas. Time (ms)	Bandwidth (kHz)	Line	Filter	Corr. (dB)
0.150000	60.13	---	66.00	5.87	1000.0	9.000	N	ON	19.1
0.188250	---	36.00	54.11	18.11	1000.0	9.000	N	ON	19.2
0.276000	44.36	---	60.94	16.57	1000.0	9.000	N	ON	19.2
0.555000	---	22.17	46.00	23.83	1000.0	9.000	N	ON	19.3
1.925250	26.36	---	56.00	29.64	1000.0	9.000	N	ON	19.2
2.193000	---	23.77	46.00	22.23	1000.0	9.000	N	ON	19.1
3.129000	32.92	---	56.00	23.08	1000.0	9.000	N	ON	19.1
3.174000	---	27.81	46.00	18.19	1000.0	9.000	N	ON	19.1
7.514250	---	23.21	50.00	26.79	1000.0	9.000	N	ON	19.2
7.775250	25.46	---	60.00	34.54	1000.0	9.000	N	ON	19.2
16.761750	33.25	---	60.00	26.75	1000.0	9.000	N	ON	19.5
19.934250	---	26.60	50.00	23.40	1000.0	9.000	N	ON	19.5

N line  
Conducted Emission from 150 KHz to 30 MHz

## 4 Main Test Equipment

Name	Type	Manufacturer	Serial Number	Last Cal.	Cal. Due Date
EMI Test Receiver	ESC13	R&S	100948	2016-06-01	2017-05-31
Signal Analyzer	FSV30	R&S	100815	2015-12-17	2016-12-16
Trilog Antenna	VULB 9163	SCHWARZBECK	9163-201	2014-12-06	2017-12-05
Horn Antenna	HF907	R&S	100126	2014-12-06	2017-12-05
Horn Antenna	3160-09	ETS-Lindgren	00102643	2015-01-30	2018-01-29
EMI Test Receiver	ESCS30	R&S	100138	2015-12-17	2016-12-16
LISN	ENV216	R&S	101171	2013-12-18	2016-12-17
Bore Sight Antenna mast	2171B	ETS	00058752	NA	NA

## ANNEX B: Product Change Description

<b>Model</b>	<b>VKY-L29</b>	<b>VKY-L09</b>
<b>Trade mark</b>	<b>HUAWEI</b>	<b>HUAWEI</b>
Frequency-GSM	the same	the same
Frequency-WCDMA	the same	the same
Frequency-LTE	the same	the same
Frequency-LTE	the same	the same
<b>SIM Card</b>	<b>Dual</b>	<b>Single</b>
Hardware Version	the same	the same
<b>Software Version</b>	<b>different</b>	<b>different</b>
Dimensions	the same	the same
Appearance	the same	the same
main antenna	the same	the same
BT/Wi-Fi antenna	the same	the same
DIV antenna	the same	the same
<b>Supported CA configurations for Inter-band CA</b>	<b>CA_3A-8A, CA_3A-20A, CA_3A-7A-8A, CA_3A-7A-20A, CA_3A-7A-28A Unsupported</b>	<b>CA_3A-8A, CA_3A-20A, CA_3A-7A-8A, CA_3A-7A-20A, CA_3A-7A-28A Supported</b>
Others	the same	the same

\*\*\*\*\*END OF REPORT \*\*\*\*\*