

Full SAR Test Report

Applicant Name: Huawei Technologies Co., Ltd.

Applicant Address: Administration Building, Headquarters of Huawei Technologies Co., Ltd., Bantian, Longgang District, Shenzhen, 518129, P.R.C

The following samples were submitted and identified on behalf of the client as:

Sample Description	Vodafone Mobile Wi-Fi
Model Number	R208
Market Name	R208
Final Software Version Tested	21.136.05.00.11
Final Hardware Version Tested	CH1E5756SM
FCC ID	QISR208
Date Initial Sample Received	07-30, 2012
Testing Start Date	08-06, 2012
Testing End Date	08-14, 2012

According to:

FCC 47CFR § 2.1093, IEEE Std C95.1-1991, IEEE Std C95.3-2005

OET Bulletin 65 Supplement C

Comments/ Conclusion:

The configuration tested complied to the certification requirements specified in this report.

Signed for on behalf of SGS

Prepared	approved

This document is issued by the Company subject to its General Conditions of Service printed overleaf, available on request or accessible at http://www.sgs.com/terms_and_conditions.htm. And, for electronic format documents to Terms and Conditions for Electronic Documents at www.sgs.com/terms_e-document.htm. Attention is drawn to the limitation of liability, indemnification and jurisdiction issues defined therein. Any holder of this document is advised that information contained hereon reflects the company's findings at the time of its intervention only and within the limits of Client's instructions, if any. The Company's sole responsibility is to its Client and this document does not exonerate parties to a transaction from exercising all their rights and obligation under the transaction documents. This document cannot be reproduced except in full, without prior written approval of the Company. Any unauthorized alteration, forgery or falsification of the content or appearance of this document is unlawful and offenders may be prosecuted to the fullest extent of the law. Unless otherwise stated the results shown in this test report refer only to the sample(s) tested and such sample(s) are retained for 30 days only

SHEMC

Table of Contents

Change History	3
1. Report Overview	4
2. Test Lab Declaration or Comments.....	4
3. Applicant Declaration or Comments.....	4
4. Full Test Report.....	4
5. Partial Test Report.....	4
6. Measurement Uncertainty.....	4
7. Testing Environment	6
8. Primary Test Laboratory	6
9. Details of Applicant	6
10. Details of Manufacturer	6
11. Other testing Locations	7
12. Referenced Documents.....	7
13. Primary Laboratory Accreditation Details	8
14. Test Equipment Information	9
14.1 SPEAG DASY4	9
14.2 The SAR Measurement System	10
14.3 Isotropic E-field Probe ES3DV3.....	12
14.4 RAM Twin Phantom	13
14.5 Device Holder for Transmitters	14
15. Detailed Test Results.....	15
15.1 Summary of Results	15
15.2 Maximum Results	21
15.3 Operation Configurations	21
15.4 Measurement procedure	27
15.5 Detailed Test Results	28
16. Identification of Samples	84
Annex A Photographs of Test Setup	85
Annex B Tissue Simulant Liquid.....	87
Annex B.1 Recipes for Tissue Simulant Liquid	87
Annex B.2 Measurement for Tissue Simulant Liquid	88
Annex C SAR System Validation.....	89
Annex D Calibration certificate	94
END OF REPORT	133

Change History

Version	Change Contents	Author	Date
V1.0	First edition	willam_wang	08-15, 2012

1. Report Overview

This report details the results of testing carried out on the samples listed in section 17, the results contained in this test report do not relate to other samples of the same product. The manufacturer should ensure that all products in series production are in conformity with the product sample detailed in this report.

This report may only be reproduced and distributed in full. If the product in this test report is used in any configuration other than that detailed in the test report, the manufacturer must ensure the new configuration complies with all relevant standards and certification requirements. Any mention of SGS Shanghai EMC lab or testing done by SGS Shanghai EMC lab made in connection with the distribution or use of the tested product must be approved in writing by SGS Shanghai EMC lab.

2. Test Lab Declaration or Comments

None

3. Applicant Declaration or Comments

None

4. Full Test Report

A full test report contains, within the results section, all the applicable test cases from the certification requirements of the permanent reference documents of the listed certification bodies.

5. Partial Test Report

A partial test report contains within the results section a sub-set of all the applicable test cases from the certification requirements of the permanent reference documents of the listed certification bodies.

6. Measurement Uncertainty

Measurements and results are all in compliance with the standards listed in section 12 of this report. All measurements and results are recorded and maintained at the laboratory performing the tests and measurement uncertainties are taken into account when comparing measurements to pass/ fail criteria.

A	b1	c	d	e = f(d,k)	g	i = cxg/e	k
Uncertainty Component	Section	Tol	Prob .	Div.	Ci	1g	Vi
	in P1528	(%)	Dist.		(1g)	ui (%)	(Veff)
Probe calibration	E.2.1	6.3	N	1	1	6.0	∞
Axial isotropy	E.2.2	0.5	R	$\sqrt{3}$	$(1-c_p)^{1/2}$	0.20	∞
hemispherical isotropy	E.2.2	2.6	R	$\sqrt{3}$	$\sqrt{c_p}$	1.06	∞
Boundary effect	E.2.3	0.8	R	$\sqrt{3}$	1	0.46	∞
Linearity	E.2.4	0.6	R	$\sqrt{3}$	1	0.35	∞
System detection limit	E.2.5	0.25	R	$\sqrt{3}$	1	0.15	∞
Readout electronics	E.2.6	0.3	N	1	1	0.3	∞
Response time	E.2.7	0	R	$\sqrt{3}$	1	0	∞
Integration time	E.2.8	2.6	R	$\sqrt{3}$	1	1.5	∞
RF ambient Condition –Noise	E.6.1	3	R	$\sqrt{3}$	1	1.73	∞
RF ambient Condition - reflections	E.6.1	3	R	$\sqrt{3}$	1	1.73	∞
Probe positioning- mechanical tolerance	E.6.2	1.5	R	$\sqrt{3}$	1	0.87	∞
Probe positioning- with respect to phantom	E.6.3	2.9	R	$\sqrt{3}$	1	1.67	∞
Max. SAR evaluation	E.5.2	1	R	$\sqrt{3}$	1	0.58	∞
Test sample positioning	E.4.2	4	N	1	1	3.7	9
Device holder uncertainty	E.4.1	3.6	N	1	1	3.6	∞
Output power variation –SAR drift measurement	6.62	5	R	$\sqrt{3}$	1	2.89	∞
Phantom uncertainty (shape and thickness tolerances)	E.3.1	4	R	$\sqrt{3}$	1	2.31	∞
Liquid conductivity - deviation from target values	E.3.2	5	R	$\sqrt{3}$	0.64	1.85	∞
Liquid conductivity - measurement uncertainty	E.3.2	4	N	1	0.64	2.56	5
Liquid permittivity - deviation from target values	E.3.3	5	R	$\sqrt{3}$	0.6	1.73	∞
Liquid permittivity - measurement uncertainty	E.3.3	4	N	1	0.6	2.40	5
Combined standard uncertainty	RSS					10.43	430

Expanded uncertainty (95% CONFIDENCE INTERVAL)	K=2	20.86
---	-----	-------

7. Testing Environment

Normal Temperature	+20 to +24 °C
Relative Humidity	35 to 60 %

8. Primary Test Laboratory

Name:	SGS-CSTC Standards Technical Services(Shanghai) Co., Ltd
Address:	No.588, West Jindu Road, Songjiang District, Shanghai, China 201612
Telephone:	+86 (0) 21 6191 5664
Fax:	+86 (0) 21 6191 5678
Internet:	http://www.cn.sgs.com
Contact:	Mr. David.Lee
Email:	David-jc.lee@sgs.com

9. Details of Applicant

Name:	Huawei Technologies Co., Ltd.
Address:	Administration Building, Headquarters of Huawei Technologies Co., Ltd., Bantian, Longgang District, Shenzhen, 518129, P.R.C
Telephone:	+86 755 28780808
Fax:	+86 755 89652518
Contact:	Xiaoru Ma
Email:	mxiaoru.ma@huawei.com

10. Details of Manufacturer

Name:	Huawei Technologies Co., Ltd
Address:	Administration Building, Huawei Base, Bantian, Longgang District, Shenzhen 518129 P.R.C
Telephone:	86-755-2878-0808
Fax:	86-755-8965-2518
Contact:	Ringchang Wang

Email:	wangrichang@huawei.com
---------------	--

11. Other testing Locations

Name:	Not Required
Address:	--
Telephone:	--
Contact:	--
Email:	--

12. Referenced Documents

The Equipment under Test (EUT) has been tested at SGS's (own or subcontracted) laboratories according to FCC 47CFR § 2.1093, IEEE Std C95.1-2005, IEEE1528-2003, IEEE Std1528a-2005, OET Bulletin 65 Supplement C,

The following table summarizes the specific reference documents such as harmonized standards or test specifications which were used for testing at SGS's (own or subcontracted) laboratories.

Identity	Document Title	Version
FCC 47CFR § 2.1093	Radiofrequency radiation exposure evaluation: portable devices	2001
IEEE Std C95.1-1991	IEEE Standard for Safety Levels with Respect to Human Exposure to Radio Frequency Electromagnetic Fields, 3 kHz to 300 GHz.	1991
IEEE Std1528-2003	IEEE Recommended Practice for Determining the Peak Spatial-Average Specific Absorption Rate (SAR) in the Human Head from Wireless Communications Devices: Measurement Techniques	2003
IEEE Std1528a-2005	IEEE Recommended Practice for Determining the Peak Spatial-Average Specific Absorption Rate (SAR) in the Human Head from Wireless Communications Devices: Measurement Techniques Amendment 1: CAD File for Human Head Model (SAM Phantom)	2005
OET Bulletin 65 Supplement C	Additional Information for Evaluating Compliance of Mobile and Portable Devices with FCC Limits for Human Exposure to Radiofrequency Emissions	2001
KDB 447498 D01	Mobile and Portable Device RF Exposure Procedures and Equipment Authorization Policies	--
KDB 248227 D01	SAR Measurement Procedures for 802.11a/b/g Transmitters	--
KDB 648474 D01	SAR Evaluation Considerations for Handsets with Multiple Transmitters and Antennas	--

SHEMC

KDB 941225 D01	SAR Measurement procedure for 3G devices	--
KDB 941225 D03	Recommended SAR Test Reduction Procedures for GSM/GPRS/EDGE	--
KDB 941225 D06	SAR Evaluation Procedures for Portable Devices with Wireless Router Capabilities	--

Human Exposure	Uncontrolled Environment General Population
Spatial Peak SAR	1.60 W/kg (averaged over a mass of 1g)

Table 12-1 RF Exposure Limits

Notes:

Uncontrolled environments are defined as locations where there is potential exposure of individuals who have no knowledge or control of their potential exposure.

13. Primary Laboratory Accreditation Details

The test facility is recognized, certified, or accredited by the following organizations:

- **CNAS (No. CNAS L0599)**

CNAS has accredited SGS-CSTC Standards Technical Services (Shanghai) Co., Ltd. to ISO/IEC 17025:2005 General Requirements for the Competence of Testing and Calibration Laboratories (CNAS-CL01 Accreditation Criteria for the Competence of Testing and Calibration Laboratories) for the competence in the field of testing. Date of expiry: 2014-07-26.

14. Test Equipment Information

14.1 SPEAG DASY4

Test Platform	SPEAG DASY4 Professional			
Location	SGS SH Lab #8			
Manufacture	SPEAG			
Description	SAR Test System (Frequency range 300MHz-3GHz) 835, 900, 1800, 1900, 2000, 2450 frequency band HAC Extension			
Software Reference	DASY4: V4.7 Build 80 SEMCAD: V1.8 Build 186			
Hardware Reference				
Equipment	Model	Serial Number	Calibration Date	Due date of calibration
Robot	RX90L	F03/5V32A1/A01	n/a	n/a
Phantom	SAM 12	TP-1283	n/a	n/a
DAE	DAE3	569	2011-11-16	2012-11-15
E-Field Probe	ES3DV3	3088	2011-11-23	2012-11-22
Validation Kits	D835V2	4d105	2011-11-11	2012-11-10
Validation Kits	D1900V2	5d028	2011-11-10	2012-11-09
Validation Kits	D2450V2	733	2011-11-09	2012-11-08
Agilent Network Analyzer	E5071B	MY42100549	2011-11-01	2012-10-31
RF Bi-Directional Coupler	ZABDC20-252H	n/a	2012-05-18	2013-05-17
Agilent Signal Generator	E4438C	14438CATO-1971 9	2011-11-01	2012-10-31
Mini-Circuits Preamplifier	ZHL-42	D041905	2011-11-01	2012-10-31
Agilent Power Meter	E4416A	GB41292095	2011-11-01	2012-10-31
Agilent Power Sensor	8481H	MY41091234	2011-11-01	2012-10-31
R&S Power Sensor	NRP-Z92	100025	2012-04-13	2013-04-12
R&S Universal Radio Communication Tester	CMU200	103633	2011-11-01	2012-10-31

14.2 The SAR Measurement System

A photograph of the SAR measurement System is given in Fig. 15-1.

This SAR Measurement System uses a Computer-controlled 3-D stepper motor system (Speag Dasy 4 professional system). A Model ES3DV3 3088 E-field probe is used to determine the internal electric fields. The SAR can be obtained from the equation $SAR = \sigma (|E|^2) / \rho$ where σ and ρ are the conductivity and mass density of the tissue-stimulant.

The DASY4 system for performing compliance tests consists of the following items:

A standard high precision 6-axis robot (Stabile RX family) with controller, teach pendant and software. An arm extension is for accommodation the data acquisition electronics (DAE).

A dissymmetric probe, i.e., an isotropic E-field probe optimized and calibrated for usage in tissue simulating liquid. The probe is equipped with an optical surface detector system.

Data acquisition electronics (DAE) which performs the signal amplification signal multiplexing, AD-conversion, offset measurements, mechanical surface detection, collision detection, etc. The unit is battery powered with standard or rechargeable batteries. The signal is optically transmitted to the EOC.

The Electro-optical converter (EOC) performs the conversion between optical and electrical of the signals for the digital communication to DAE and for the analog signal from the optical surface detection. The EOC is connected to the measurement server.

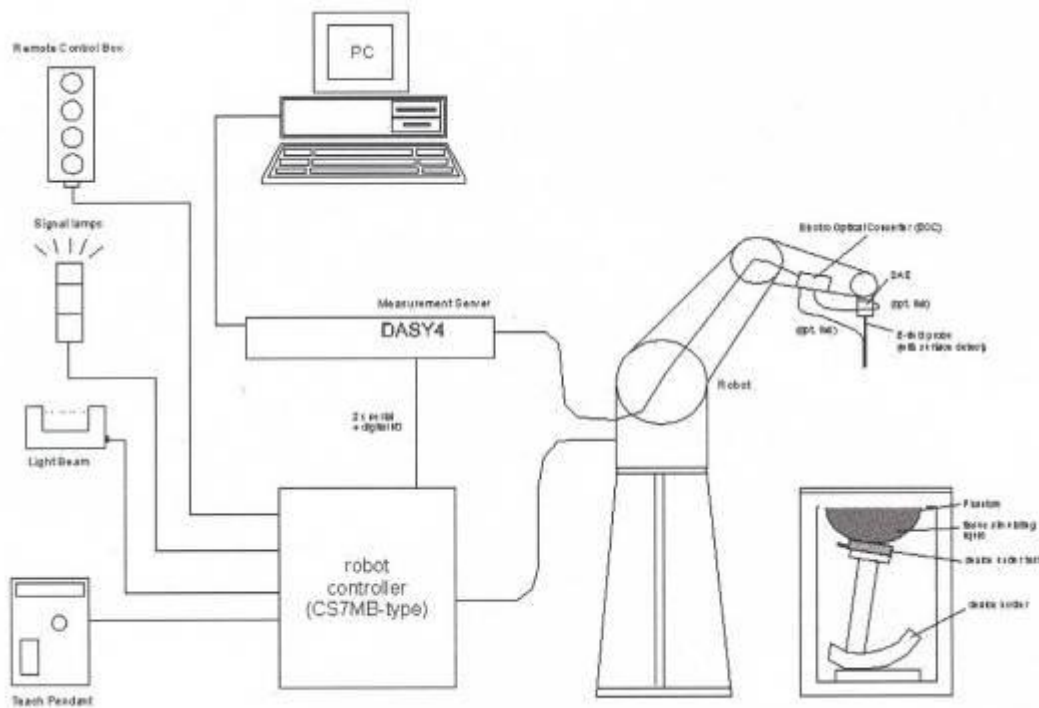


Fig. 14-1 SAR System Configuration

- Y The function of the measurement server is to perform the time critical tasks such as signal filtering, control of the robot operation and fast movement interrupts.
- Y A probe alignment unit which improves the (absolute) accuracy of the probe positioning.
- Y A computer operating Windows 2000.
- Y DASY4 software.
- Y Remote control with teach pendant and additional circuitry for robot safety such as warning lamps, etc.
- Y The SAM twin phantom enabling testing left-hand, right-hand and Hotspot body usage.
- Y The device holder for handheld mobile phones.
- Y Tissue simulating liquid mixed according to the given recipes.
- Y Validation dipole kits allowing to validating the proper functioning of the system.

14.3 Isotropic E-field Probe ES3DV3

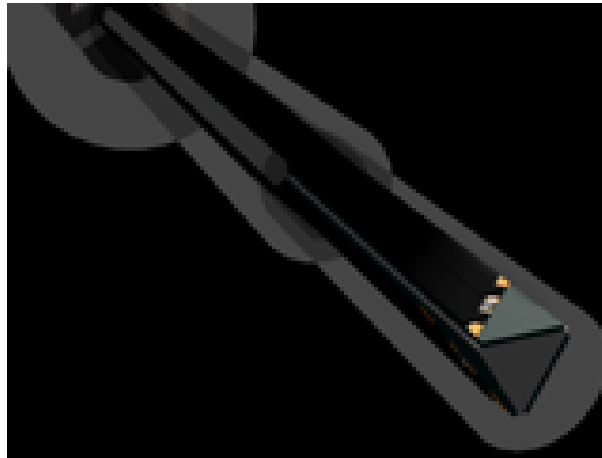


Fig. 14-2 E-field Probe

Construction	Symmetrical design with triangular core Interleaved sensors Built-in shielding against static charges PEEK enclosure material (resistant to organic solvents, e.g., DGBE)
Calibration	Basic Broad Band Calibration in air Conversion Factors (CF) for HSL 900 and HSL 1810 Additional CF for other liquids and frequencies upon request
Frequency	10 MHz to 4 GHz; Linearity: ± 0.2 dB (30 MHz to 4 GHz)
Directivity	± 0.2 dB in HSL (rotation around probe axis) ± 0.3 dB in tissue material (rotation normal to probe axis)
Dynamic Range	5 μ W/g to > 100 mW/g; Linearity: ± 0.2 dB
Dimensions	Overall length: 330 mm (Tip: 20 mm) Tip diameter: 3.9 mm (Body: 12 mm) Distance from probe tip to dipole centers: 2.0 mm
Application	General dosimetry up to 4 GHz Dosimetry in strong gradient fields Compliance tests of mobile phones

14.4 RAM Twin Phantom



Fig. 14-3 SAM Twin Phantom

The SAM twin phantom is a fiberglass shell phantom with 2mm shell thickness (except the ear region where shell thickness increases to 6mm). It has three measurement areas:

- Left hand
- Right hand
- Flat phantom

A white cover is provided to tap the phantom during off-periods to prevent water evaporation and changes in the liquid parameters. Free space scans of devices on the cover are possible.

On the phantom top, three reference markers are provided to identify the phantom position with respect to the robot.

Phantom specification:

Description	The shell corresponds to the specifications of the Specific Anthropomorphic Mannequin (SAM) phantom defined in IEEE 1528-2003, CENELEC 50361 and IEC 62209. It enables the dosimetric evaluation of left and right hand phone usage as well as body mounted usage at the flat phantom region. A cover prevents evaporation of the liquid. Reference markings on the phantom allow the complete setup of all predefined phantom positions and measurement grids by teaching three points with the robot.
Shell Thickness	2+0.2mm, Center ear point: 6+0.2mm
Filling Volume	Approx.25 liters
Dimensions	Length: 1000mm, Width: 500mm, Height: 850mm

14.5 Device Holder for Transmitters



Fig. 14-4 Device Holder for Transmitters

The SAR in the phantom is approximately inversely proportional to the square of the distance between the source and the liquid surface. For a source in 5mm distance, a positioning uncertainty of $\pm 0.5\text{mm}$ would produce a SAR uncertainty of $\pm 20\%$. An accurate device positioning is therefore crucial for accurate and repeatable measurements. The positions, in which the devices must be measured, are defined by the standards.

The DASY device holder is designed to cope with different positions given in the standard. It has two scales for the device rotation (with respect to the body axis) and the device inclination (with respect to the line between the ear reference points). The rotation centers for both scales are the ear reference point (ERP). Thus the device needs no repositioning when changing the angles.

The DASY device holder has been made out of low-loss POM material having the following dielectric parameters: relative permittivity $\epsilon_r=3$ and loss tangent $\tan \delta=0.02$. The amount of dielectric material has been reduced in the closest vicinity of the device, since measurements have suggested that the influence of the clamp on the test results could thus be lowered.

15. Detailed Test Results

15.1 Summary of Results

15.1.1 Measurement of RF conducted Power (dBm)

GSM 850&1900

Mode		GPRS							
Slot (Uplink)		1		2		3		4	
/		burst	averaged	burst	averaged	burst	averaged	burst	averaged
Band	Channel	GMSK							
850	128	32.93	23.74	30.94	24.76	28.97	24.55	27	23.83
	190	33.01	23.82	31.05	24.87	29.06	24.64	27.05	23.88
	251	33.02	23.83	31.11	24.93	29.11	24.69	27.11	23.94
1900	512	30.42	21.23	28.34	22.16	26.29	21.87	24.33	21.16
	661	30.29	21.1	28.25	22.07	26.23	21.81	24.26	21.09
	810	30.18	20.99	28.15	21.97	26.12	21.7	24.17	21

Mode		EGPRS							
Slot (Uplink)		1		2		3		4	
/		burst	averaged	burst	averaged	burst	averaged	burst	averaged
Band	Channel	GMSK							
850	128	32.95	23.76	30.92	24.74	28.99	24.57	27.01	23.84
	190	33.02	23.83	31.06	24.88	29.08	24.66	27.04	23.87
	251	33.02	23.83	31.15	24.97	29.14	24.72	27.15	23.98
1900	512	30.45	21.26	28.31	22.13	26.3	21.88	24.32	21.15
	661	30.28	21.09	28.26	22.08	26.25	21.83	24.28	21.11
	810	30.18	20.99	28.12	21.94	26.13	21.71	24.15	20.98

Mode		EGPRS							
Slot (Uplink)		1		2		3		4	
/		burst	averaged	burst	averaged	burst	averaged	burst	averaged
Band	Channel	8PSK							
850	128	26.26	17.07	24.01	17.83	21.73	17.31	19.53	16.36
	190	26.12	16.93	23.91	17.73	21.69	17.27	19.42	16.25
	251	26.05	16.86	23.88	17.7	21.57	17.15	19.38	16.21
1900	512	25.21	16.02	23.02	16.84	20.92	16.5	18.64	15.47
	661	25.15	15.96	22.97	16.79	20.89	16.47	18.68	15.51
	810	24.91	15.72	22.79	16.61	20.71	16.29	18.64	15.47

WCDMA Band V

WCDMA		RMC			
		12.2kbps	64kbps	144kbps	384kbps
Band	Channel	QPSK			
Band V	4132	22.77	22.69	22.74	22.68
	4182	22.78	22.85	22.83	22.86
	4233	22.61	22.62	22.59	22.58

HSDPA		SUBTEST			
		1	2	3	4
Band	Channel	QPSK			
Band V	4132	22.79	22.66	22.34	22.42
	4182	22.82	22.74	22.46	22.39
	4233	22.64	22.66	22.34	22.28

HSUPA		SUBTEST				
		1	2	3	4	5
Band	Channel	QPSK				
Band V	4132	21.43	20.57	20.48	20.3	21.46
	4182	21.39	20.59	20.5	20.38	21.5
	4233	21.34	20.51	20.39	20.21	21.37

DC-HSDPA		SUBTEST			
		1	2	3	4
Band	Channel	QPSK			
Band V	4132	22.78	22.79	22.48	22.58
	4182	22.82	22.85	22.61	22.49
	4233	22.67	22.63	22.45	22.40

WIFI

	Channel	Average Power (dBm) for Data Rates (Mbps)							
		1	2	5.5	11	/	/	/	/
802.11b	1	15.04	14.97	14.89	15.02				
	6	14.48	14.46	14.47	14.56				
	11	13.87	13.91	13.76	13.81				
	Channel	6	9	12	18	24	36	48	54
802.11g	1	12.34	12.31	12.32	12.29	12.33	12.27	12.35	12.28
	6	11.89	11.82	11.84	11.78	11.79	11.82	11.86	11.84
	11	11.34	11.46	11.57	11.67	11.58	11.49	11.53	11.43
	Channel	6.5	13	19.5	26	39	52	58.5	65
802.11n	1	10.23	10.21	10.22	10.14	10.19	10.16	10.13	10.04
	6	9.89	9.81	9.79	9.75	9.69	9.81	9.64	9.75
	11	9.34	9.51	9.67	9.37	9.78	9.64	9.43	9.37

15.1.2 Measurement of SAR average value

GSM 850

Band	EUT Position	Mode	Test Configuration	Averaged SAR over 1g (W/kg)			SAR limit 1g (W/kg)	Verdict	
				CH128	CH190	CH251			
				824.2MHz	836.6MHz	848.8MHz			
GSM850	Hotspot body	GPRS 1TS	Front of EUT facing phantom	0.913	0.964	0.983	1.6	Passed	
		GPRS 2TS	Front of EUT facing phantom	--	0.796	--	1.6	Passed	
		GPRS 3TS	Front of EUT facing phantom	0.818	0.849	0.835	1.6	Passed	
		GPRS 4TS	Front of EUT facing phantom	0.852	0.887	0.880	1.6	Passed	
		GPRS 1TS	Back of EUT facing phantom	0.769	0.933	0.879	1.6	Passed	
		GPRS 1TS	Top of EUT facing phantom	--	0.444	--	1.6	Passed	
		GPRS 1TS	Bottom of EUT facing phantom	--	0.539	--	1.6	Passed	
		GPRS 1TS	Right of EUT facing phantom	--	0.137	--	1.6	Passed	
		Worst case of GPRS in EGPRS 1TS			--	--	0.969	1.6	Passed
		Worst case of GPRS in EGPRS 2TS			--	--	0.780	1.6	Passed
		Worst case of GPRS in EGPRS 3TS			--	--	0.863	1.6	Passed
		Worst case of GPRS in EGPRS 4TS			--	--	0.902	1.6	Passed

GSM 1900

Band	EUT Position	Mode	Test Configuration	Averaged SAR over 1g (W/kg)			SAR limit 1g (W/kg)	Verdict	
				CH512	CH661	CH810			
				1850.2MHz	1880MHz	1909.8MHz			
GSM1900	Hotspot body	GPRS 1TS	Front of EUT facing phantom	--	0.720	--	1.6	Passed	
		GPRS 2TS	Front of EUT facing phantom	--	0.717	--	1.6	Passed	
		GPRS 3TS	Front of EUT facing phantom	--	0.759	--	1.6	Passed	
		GPRS 4TS	Front of EUT facing phantom	--	0.797	--	1.6	Passed	
		GPRS 4TS	Back of EUT facing phantom	--	0.471	--	1.6	Passed	
		GPRS 4TS	Top of EUT facing phantom	--	0.135	--	1.6	Passed	
		GPRS 4TS	Bottom of EUT facing phantom	--	0.084	--	1.6	Passed	
		GPRS 4TS	Right of EUT facing phantom	1.01	1.11	1.19	1.6	Passed	
		Worst case of GPRS in EGPRS 1TS			--	--	1.04	1.6	Passed
		Worst case of GPRS in EGPRS 2TS			--	--	1.05	1.6	Passed
		Worst case of GPRS in EGPRS 3TS			--	--	1.1	1.6	Passed
		Worst case of GPRS in EGPRS 4TS			--	--	1.16	1.6	Passed

WCDMA Band V

Band	EUT Position	Mode	Test Configuration	Averaged SAR over 1g (W/kg)			SAR limit 1g (W/kg))	Verdict
				CH4132	CH4182	CH4233		
				826.4MHz	836.4MHz	846.6MHz		
WCDMA Band V	Hotspot body	12.2 kbps RMC	Front of EUT facing phantom	0.927	0.912	0.870	1.6	Passed
			Back of EUT facing phantom	0.871	0.911	0.885	1.6	Passed
			Top of EUT facing phantom	--	0.417	--	1.6	Passed
			Bottom of EUT facing phantom	--	0.535	--	1.6	Passed
			Right of EUT facing phantom	--	0.137	--	1.6	Passed
		Worst case of WCDMA in HSDPA	0.936	--	--	1.6	Passed	
		Worst case of WCDMA in HSUPA	0.741	--	--	1.6	Passed	

WIFI

Band	EUT Position	Mode	Test Configuration	Averaged SAR over 10g (W/kg)			SAR limit 10g (W/kg))	Verdict
				CH1	CH6	CH11		
				2412MHz	2437MHz	2462MHz		
WIFI	Hotspot body	802.11b	Front of EUT facing phantom	0.123	0.139	0.111	1.6	Passed
			Back of EUT facing phantom	--	0.029	--	1.6	Passed
			Top of EUT facing phantom	--	0.086	--	1.6	Passed
		Worst case of 802.11b in 802.11g	--	0.079	--	1.6	Passed	
		Worst case of 802.11b in 802.11n	--	0.064	--	1.6	Passed	

15.2 Maximum Results

The maximum measured SAR values for Hotspot body configuration are given in section 15.2.1.

15.2.1 Hotspot body Configuration

Frequency Band	EUT Position	Conducted Power (dBm)	SAR, Averaged over 1g (W/kg)	Power Drift (dB)	SAR limit (W/kg)	Verdict
GSM850	GPRS 1TS/Front of EUT facing phantom/High	23.83	0.983	-0.185	1.6	Passed
GSM 1900	GPRS 4TS/Right of EUT facing phantom/High	21	1.19	-0.111	1.6	Passed
WCDMA Band V	HSDPA/Front of EUT facing phantom/Low	22.79	0.936	-0.173	1.6	Passed
WIFI	802.11b/Front of EUT facing phantom/Middle	14.48	0.139	0.200	1.6	Passed

According to 15.2.1 The Max Add WIFI SAR value and other SAR value together is Right Side High Condition. SAR value is 0w/kg and 1.19 w/kg Separately . so the sum of them is $0+1.19=1.19\text{w/kg} < 1.6\text{w/kg}$. According to KDB 648474 D01 the simultaneous transmission SAR are not required.

15.2.2 Maximum Drift

Maximum Drift during measurement	-0.201dB
----------------------------------	----------

15.2.3 Measurement Uncertainty

Extended Uncertainty (k=2) 95%	20.86%
--------------------------------	--------

15.3 Operation Configurations

15.3.1

The EUT is controlled by using a radio communication tester (CMU200) with air link, and the EUT is set to maximum output power by CMU200 during all tests.

1. Testing SAR at GSM/WCDMA mode for all bands at positions 15.3.3 shows.
2. SAR with accessories should be done at worstcase to identify maximum SAR value.
3. Testing Body SAR at WCDMA mode for all bands. HSDPA, HSUPA modes are selectively confirmed
4. Test reduction has been adopted according to conducted output power and produced SAR level:

Low and High channel SAR are optional if SAR value produced in the middle channel is 3dB lower than the applicable SAR limit;

SHEMC

In GPRS mode, the multislot configuration which produces highest SAR value is regard as the worst case to be measured, other multislot configurations are selectively confirmed;

5. The (max.cube) labeling indicates that during the grid scanning an additional peak was found which within 2dB of the highest peak

6. WCDMA was tested in 12.2kbps RMC Mode and HSDPA was tested in subtest 1, HSUPA was tested in subtest 5 according the power of the EUT.

7. DC-HSDPA

In DC-HSDPA implementation of this device,the uplink parameters are the same as HSDPA.No additional channels and modulations(16 QAM,and 64 QAM) are supported in uplink.The difference is only in the downlink parameters,where two carriers are supported.HSDPA settings were used on uplink.

According to the KDB Inquiry ,for Rel.8 DC-HSDPA apply the four subtests from HSDPA Release 5 except use fixed reference channel H-Set 12 for DC-HSDPA.And we can apply the same SAR test exclusion criteria used for Rel.6 HSPA for Rel.7 HSPA+ and Rel.8 DC-HSDPA.That is,if the HSPA,HSPA+,or the DC-HSDPA maximum output is not more than 0.25 dB higher than WCDMA,SAR measurement for those modes is not required.

The following tests were completed according to procedures in section 7.3.13 of 3GPP TS 34.108 v9.5.0.A summary of these settings are illustrated below:

Downlink Physical Channels are set as per 3GPP TS 34.121-1 v9.0.0 E.5.0

Table E.5.0: Levels for HSDPA connection setup

Parameter During Connection setup	Unit	Value
P-CPICH_Ec/Ior	dB	-10
P-CCPCH and SCH_Ec/Ior	dB	-12
PICH_Ec/Ior	dB	-15
HS-PDSCH	dB	off
HS-SCCH_1	dB	off
DPCH_Ec/Ior	dB	-5
OCNS_Ec/Ior	dB	-3.1

Call is set up as per 3GPP TS 34.108 v9.5.0 sub clause 7.3.13

The configurations of the fixed reference channels for HSDPA RF tests are described in 3GPP TS 34.121,annex C for FDD and 3GPP TS 34.122.

The measurements were performed with a Fixed Reference Channel(FRC) H-Set 12 with QPSK

Parameter	Value
Nominal average inf.bit rate	60 kbit/s
Inter-TTI Distance	1 TTI's
Number of HARQ Processes	6 Processes
Information Bit Payload	120 Bits
Binary Channel Bits Per TTI	960 Bits
Total Available SMLs in UE	19200 SMLs
Number of SMLs per HARQ Process	3200SMLs
Coding Rate	0.15
Number of Physical Channel Codes	1

Table 15:settings of required H-Set 12 QPSK acc.to 3GPP 34.121

Note:

1. The RMC is intended to be used for DC-HSDPA mode and both cells shall transmit with identical parameters as listed in the table above.
2. Maximum number of transmission is limited to 1,i.e.,retransmission is not allowed.The redundancy and constellation version 0 shall be used.

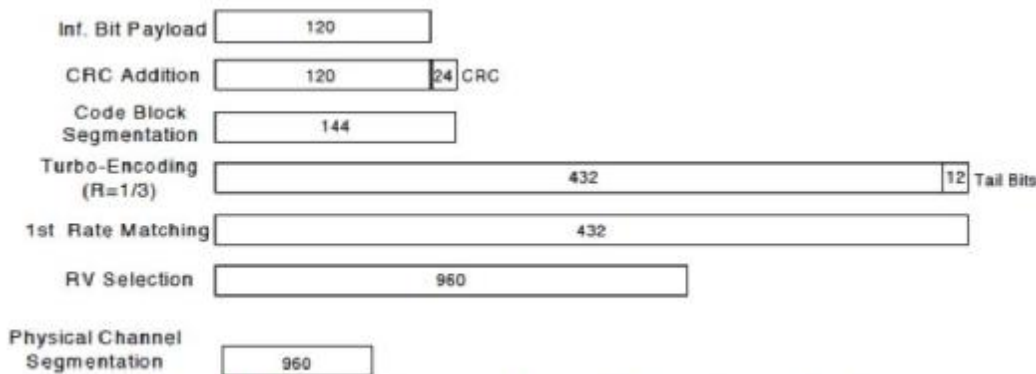


Figure C.8.19: Coding rate for Fixed reference Channel H-Set 12 (QPSK)

The following 4 Sub-tests for HSDPA were completed according to Release 5 procedures.A summary of subtest settings are illustrated below:

Sub-test ¹	β_c ²	β_d ²	β_d (SF) ²	β_c/β_d ²	$\beta_{tr}(1)$ ²	CM(dB)(2) ²	MPR (dB) ²
1 ²	2/15 ²	15/15 ²	64 ²	2/15 ²	4/15 ²	0.0 ²	0 ²
2 ²	12/15(3) ²	15/15(3) ²	64 ²	12/15(3) ²	24/15 ²	1.0 ²	0 ²
3 ²	15/15 ²	8/15 ²	64 ²	15/8 ²	30/15 ²	1.5 ²	0.5 ²
4 ²	15/15 ²	4/15 ²	64 ²	15/4 ²	30/15 ²	1.5 ²	0.5 ²

Note 1: Δ ACK, Δ NACK and Δ CQI=8 $A_{tr} = \beta_{tr}/\beta_c = 30/15$ $\beta_{tr} = 30/15 * \beta_c$
 Note 2: CM=1 for $\beta_c/\beta_d=12/15$, $\beta_{tr}/\beta_c = 24/15$. For all other combinations of DPDCH,DPCCH and HS-DPCCH the MPR is based on the relative CM difference. This is applicable for only UEs that support HSDPA in release 6 and later releases.
 Note 3: For subtest 2 the β_c/β_d ratio of 12/15 for the TFC during the measurement period (TF1, TF0) is achieved by setting the signalled gain factors for the reference TFC (TF1, TF1) to $\beta_c = 11/15$ and $\beta_d = 15/15$

Up commands are set continuously to set the UE to Max power.

Note:

1. The Dual Carriers transmission only applies to HSDPA physical channels
2. The Dual Carriers belong to the same Node and are on adjacent carriers.
3. The Dual Carriers do not support MIMO to serve UEs configured for dual cell operation
4. The Dual Carriers operate in the same frequency band.
5. The device doesn't support the modulation of 16QAM in uplink but 64QAM in down link for DC-HSDPA mode.
6. The device doesn't support carriers aggregation for its release version is Release 8.

15.3.2

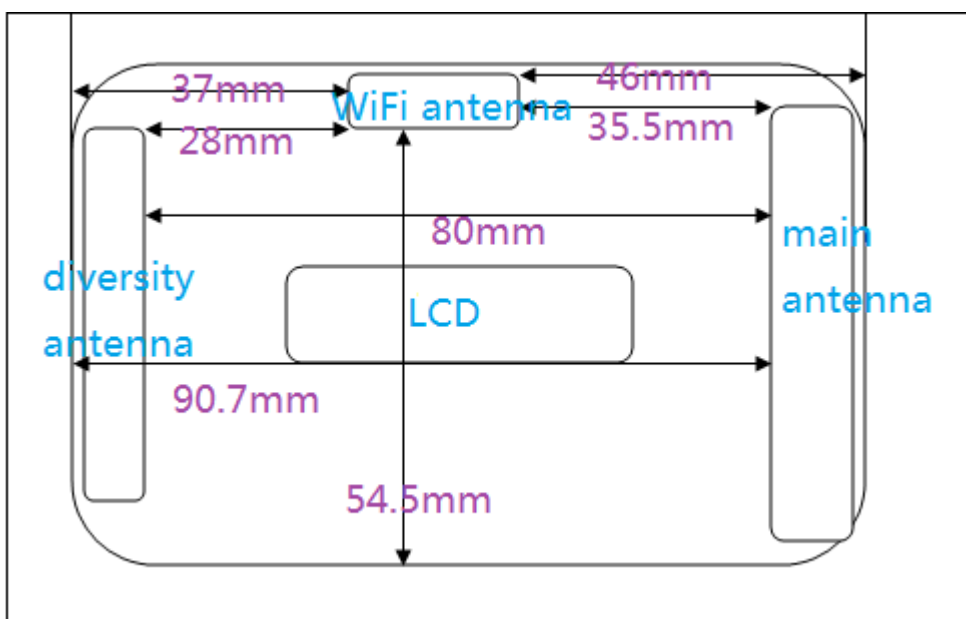
The EUT is measured using chipset based test mode software to ensure the results are consistent and reliable, during the 802.11b/g/n mode tests.

1. The 802.11b mode is tested at 1,6,11 channels.
2. The 802.11g/n mode is checked at worst case of 802.11b mode.
3. The EUT is at the lowest data rate during test according the power of the EUT.
4. Test reduction has been adopted according to conducted output power and produced SAR level:

Low and High channel SAR are optional if SAR value produced in the middle channel is 3dB lower than the applicable SAR limit;

5. The (max. cube) labeling indicates that during the grid scanning an additional peak was found which within 2dB of the highest peak

15.3.3 The test positions



SHEMC

Fig 15-1

15.3.3.1 As the Fig 15-1 shows the closest distance between the left side and the Tx antenna is 90.7mm>25mm

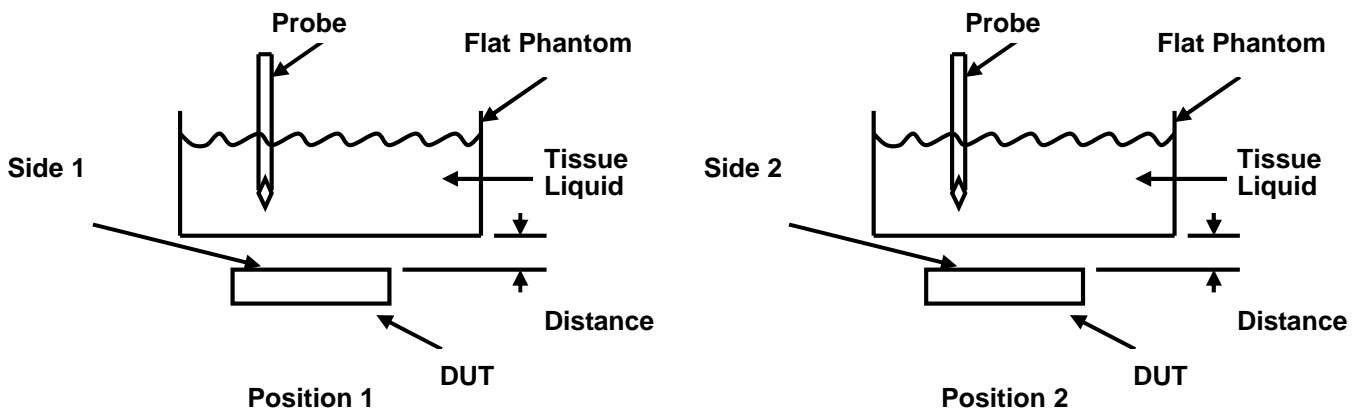
15.3.3.2 As the Fig 15-1 shows the closest distance between the left side and the WiFi antenna is 37mm>25mm and the closest distance between the Right side and the WiFi antenna is 46mm>25mm ,the closest distance between the Bottom side and the WiFi antenna is 54.5mm>25mm.According to KDB 941225 D06 the left side SAR is not required .

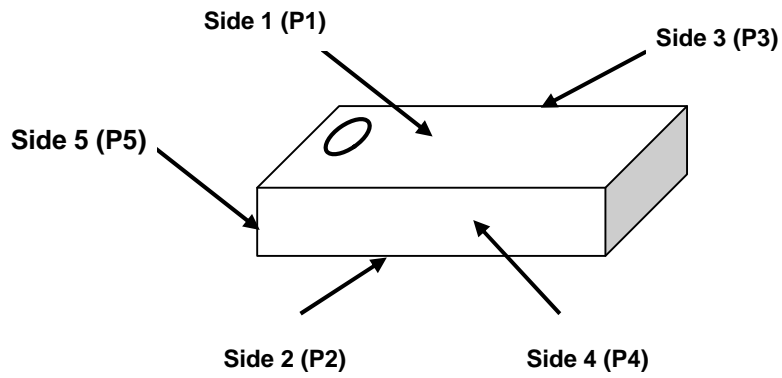
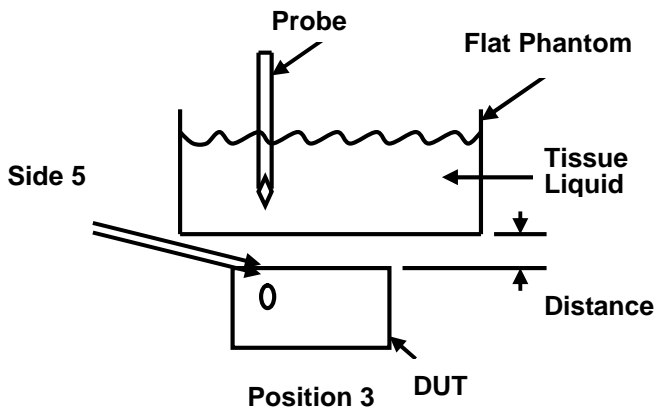


Fig 15-2

15.3.3.3 As Fig 15-2 shows the form factor of EUT is 10.5cm*5.5cm>9cm*5cm.According to KDB 941225 D06 the test distance would be 10mm.

15.3.3.4 Test positions of EUT (the distance between the EUT and the phantom is 10mm for the three sides)





15.4 Measurement procedure

Step 1: Power reference measurement

The SAR measurement was taken at a selected spatial reference point to monitor power variations during testing. This fixed location point was measured and used as a reference value.

Step 2: Area scan

The SAR distribution at the exposed side of the head was measured at a distance of 4mm from the inner surface of the shell. The area covered the entire dimension of the head and the horizontal grid spacing was 15mm*15mm or 10mm*10mm. Based on the area scan data, the area of the maximum absorption was determined by spline interpolation.

Step 3: Zoom scan

Around this point, a volume of 30mm*30mm*30mm (fine resolution volume scan, zoom scan) was assessed by measuring 7*7*7 points. On this basis of this data set, the spatial peak SAR value was evaluated with the following procedure:

The data at the surface was extrapolated, since the center of the dipoles is 2.0mm away from the tip of the probe and the distance between the surface and the lowest measuring point is 1.2mm. (This can be variable. Refer to the probe specification) the extrapolation was based on a least square algorithm. A polynomial of the fourth order was calculated through the points in z-axes. This polynomial was then used to evaluate the points between the surface and the probe tip. The maximum interpolated value was searched with a straight-forward algorithm. Around this maximum the SAR values averaged over the spatial volumes (1g or 10g) were computed using the 3D-Spline interpolation algorithm. The volume was integrated with the trapezoidal algorithm. One thousand points (10*10*10) were interpolated to calculate the average. All neighboring volumes were evaluated until no neighboring volume with a higher average value was found.

Step 4: Power reference measurement (drift)

The SAR value at the same location as in step 1 was again measured. (If the value changed by more than 5%, the evaluation should be done repeatedly)

15.5 Detailed Test Results

16.5.1 GSM 850+GPRS 1TS-Hotspot body-FrontSide-Middle

Date/Time: 2012-8-7 14:57:21

Test Laboratory: SGS-GSM

R208 GSM 850+GPRS 1TS Hotspot body Front Middle

DUT: R208; Type: GSM/WCDMA/WIFI; Serial: 866322010006055

Communication System: GSM850-GPRS Mode(1up); Frequency: 836.6 MHz;Duty Cycle: 1:8.3

Medium: HSL835_Body Medium parameters used: f = 836.6 MHz; σ = 0.99 mho/m; ϵ_r = 56.5; ρ = 1000 kg/m³

Phantom section: Flat Section

DASY4 Configuration:

- Probe: ES3DV3 - SN3088; ConvF(6.13, 6.13, 6.13); Calibrated: 2011-11-23
- Sensor-Surface: 4mm (Mechanical Surface Detection)
- Electronics: DAE3 Sn569; Calibrated: 2011-11-16
- Phantom: SAM 12; Type: SAM V4.0; Serial: TP-1283
- Measurement SW: DASY4, V4.7 Build 80; Postprocessing SW: SEMCAD, V1.8 Build 186

Middle/Area Scan (51x101x1): **Measurement grid: dx=15mm, dy=15mm**

Maximum value of SAR (interpolated) = 1.01 mW/g

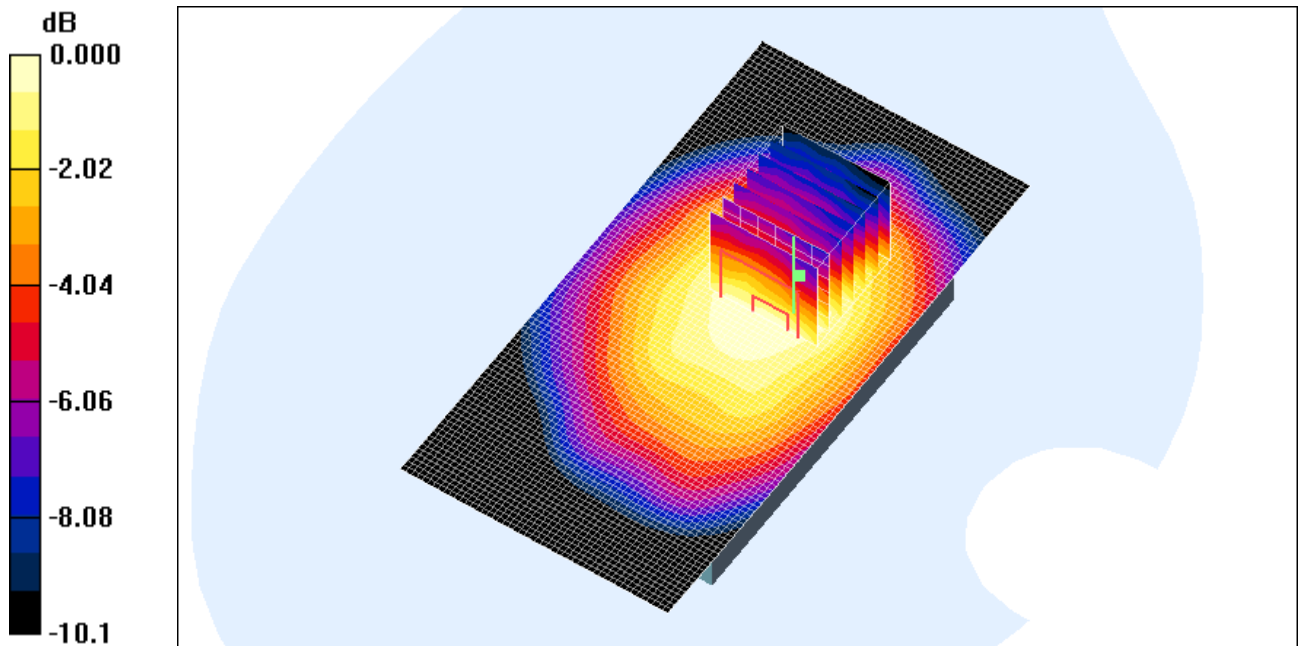
Middle/Zoom Scan (7x7x7)/Cube 0: **Measurement grid: dx=5mm, dy=5mm, dz=5mm**

Reference Value = 30.3 V/m; Power Drift = -0.0488 dB

Peak SAR (extrapolated) = 1.15 W/kg

SAR(1 g) = 0.964 mW/g; SAR(10 g) = 0.713 mW/g

Maximum value of SAR (measured) = 1.05 mW/g



0 dB = 1.05mW/g

16.5.2 GSM 850+GPRS 1TS-Hotspot body-FrontSide-High

Date/Time: 2012-8-7 15:22:08

Test Laboratory: SGS-GSM

R208 GSM 850+GPRS 1TS Hotspot body Front High

DUT: R208; Type: GSM/WCDMA/WIFI; Serial: 866322010006055

Communication System: GSM850-GPRS Mode(1up); Frequency: 848.8 MHz;Duty Cycle: 1:8.3

Medium: HSL835_Body Medium parameters used: f = 848.8 MHz; $\sigma = 1$ mho/m; $\epsilon_r = 56.4$; $\rho = 1000$ kg/m³

Phantom section: Flat Section

DASY4 Configuration:

- Probe: ES3DV3 - SN3088; ConvF(6.13, 6.13, 6.13); Calibrated: 2011-11-23
- Sensor-Surface: 4mm (Mechanical Surface Detection)
- Electronics: DAE3 Sn569; Calibrated: 2011-11-16
- Phantom: SAM 12; Type: SAM V4.0; Serial: TP-1283
- Measurement SW: DASY4, V4.7 Build 80; Postprocessing SW: SEMCAD, V1.8 Build 186

High/Area Scan (51x101x1): **Measurement grid: dx=15mm, dy=15mm**

Maximum value of SAR (interpolated) = 1.26 mW/g

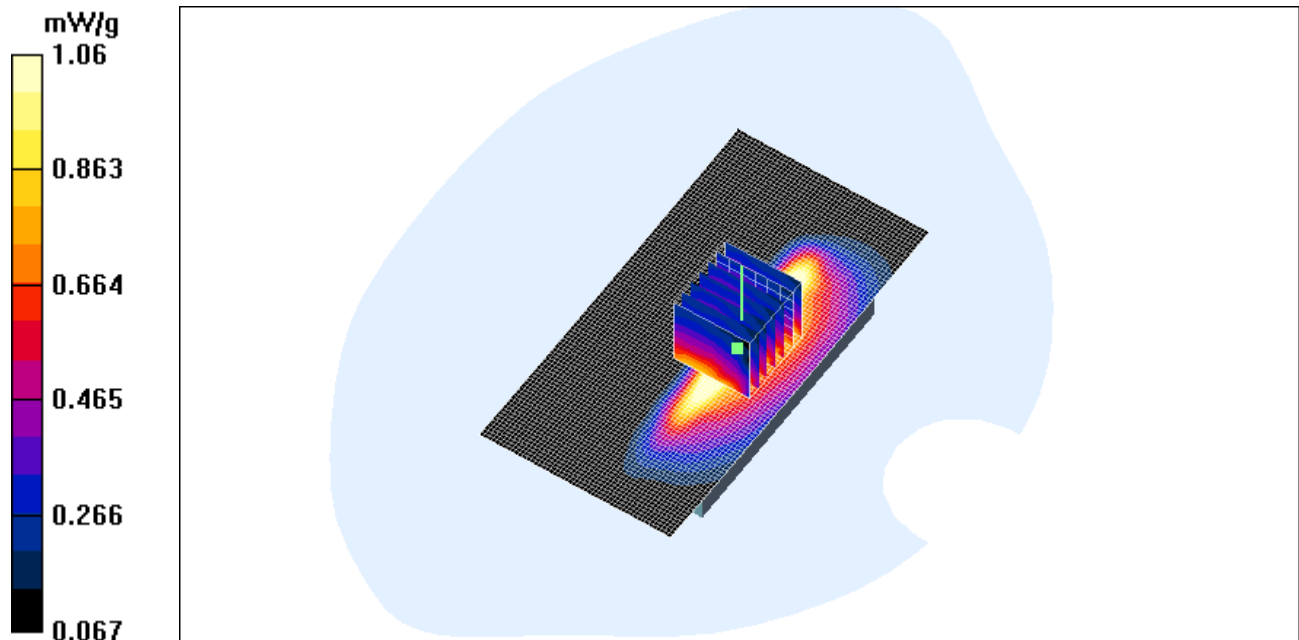
High/Zoom Scan (7x7x7)/Cube 0: **Measurement grid: dx=5mm, dy=5mm, dz=5mm**

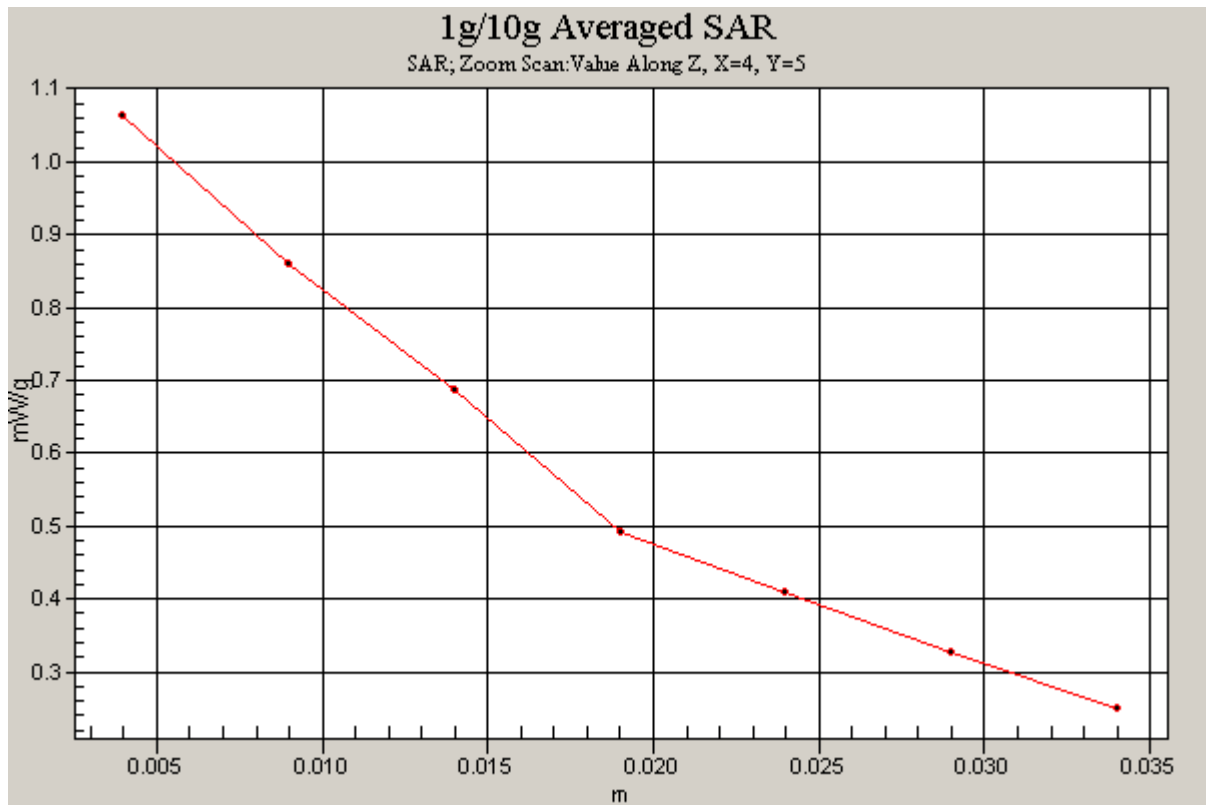
Reference Value = 30.4 V/m; Power Drift = -0.185 dB

Peak SAR (extrapolated) = 1.20 W/kg

SAR(1 g) = 0.983 mW/g; SAR(10 g) = 0.746 mW/g

Maximum value of SAR (measured) = 1.06 mW/g





16.5.3 GSM 850+GPRS 1TS-Hotspot body-FrontSide-Low

Date/Time: 2012-8-7 15:46:45

Test Laboratory: SGS-GSM

R208 GSM 850+GPRS 1TS Hotspot body Front Low

DUT: R208; Type: GSM/WCDMA/WIFI; Serial: 866322010006055

Communication System: GSM850-GPRS Mode(1up); Frequency: 824.2 MHz;Duty Cycle: 1:8.3

Medium: HSL835_Body Medium parameters used: f = 824.2 MHz; $\sigma = 0.978$ mho/m; $\epsilon_r = 56.6$; $\rho = 1000$ kg/m³

Phantom section: Flat Section

DASY4 Configuration:

- Probe: ES3DV3 - SN3088; ConvF(6.13, 6.13, 6.13); Calibrated: 2011-11-23
- Sensor-Surface: 4mm (Mechanical Surface Detection)
- Electronics: DAE3 Sn569; Calibrated: 2011-11-16
- Phantom: SAM 12; Type: SAM V4.0; Serial: TP-1283
- Measurement SW: DASY4, V4.7 Build 80; Postprocessing SW: SEMCAD, V1.8 Build 186

Low/Area Scan (51x101x1): **Measurement grid: dx=15mm, dy=15mm**

Maximum value of SAR (interpolated) = 0.992 mW/g

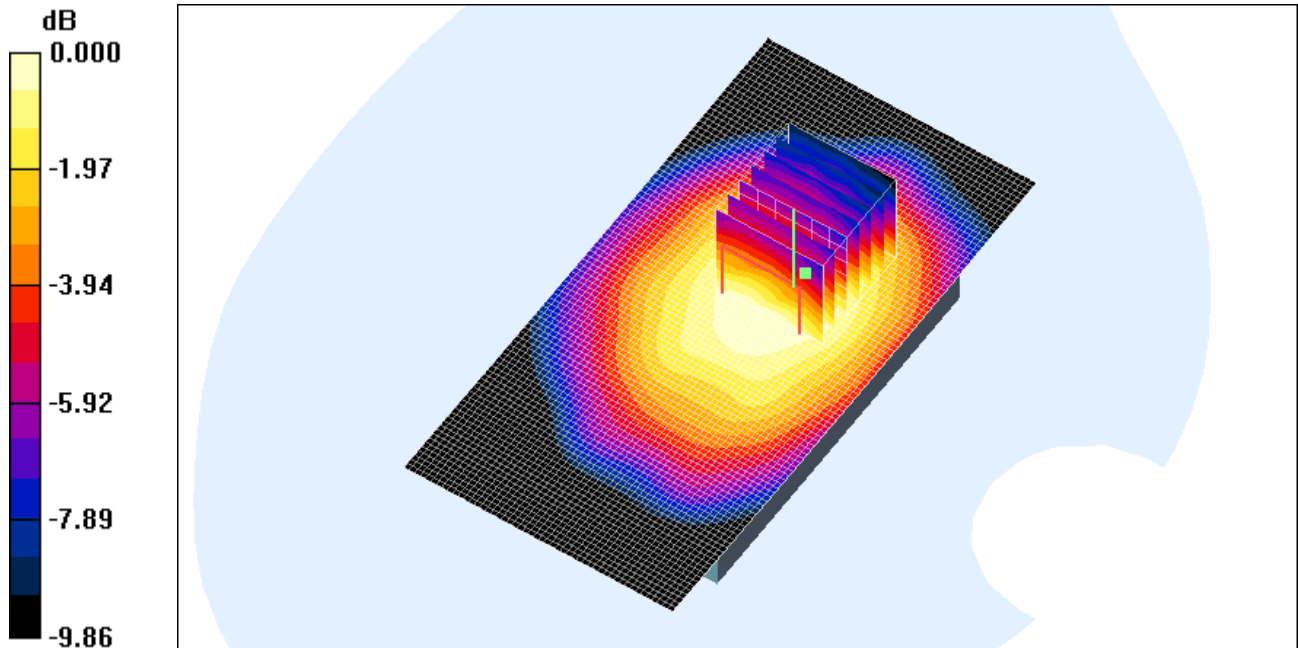
Low/Zoom Scan (7x7x7)/Cube 0: **Measurement grid: dx=5mm, dy=5mm, dz=5mm**

Reference Value = 29.9 V/m; Power Drift = -0.0616 dB

Peak SAR (extrapolated) = 1.14 W/kg

SAR(1 g) = 0.913 mW/g; SAR(10 g) = 0.689 mW/g

Maximum value of SAR (measured) = 0.988 mW/g



0 dB = 0.988mW/g

16.5.4 GSM 850+GPRS 2TS-Hotspot body-FrontSide-Middle

Date/Time: 2012-8-7 16:12:14

Test Laboratory: SGS-GSM

R208 GSM 850+GPRS 2TS Hotspot body Front Middle

DUT: R208; Type: GSM/WCDMA/WIFI; Serial: 866322010006055

Communication System: GSM850-GPRS Mode(2up); Frequency: 836.6 MHz; Duty Cycle: 1:4.15

Medium: HSL835_Body Medium parameters used: f = 836.6 MHz; $\sigma = 0.99$ mho/m; $\epsilon_r = 56.5$; $\rho = 1000$ kg/m³

Phantom section: Flat Section

DASY4 Configuration:

- Probe: ES3DV3 - SN3088; ConvF(6.13, 6.13, 6.13); Calibrated: 2011-11-23
- Sensor-Surface: 4mm (Mechanical Surface Detection)
- Electronics: DAE3 Sn569; Calibrated: 2011-11-16
- Phantom: SAM 12; Type: SAM V4.0; Serial: TP-1283
- Measurement SW: DASY4, V4.7 Build 80; Postprocessing SW: SEMCAD, V1.8 Build 186

Middle 2/Area Scan (51x101x1): **Measurement grid: dx=15mm, dy=15mm**

Maximum value of SAR (interpolated) = 0.843 mW/g

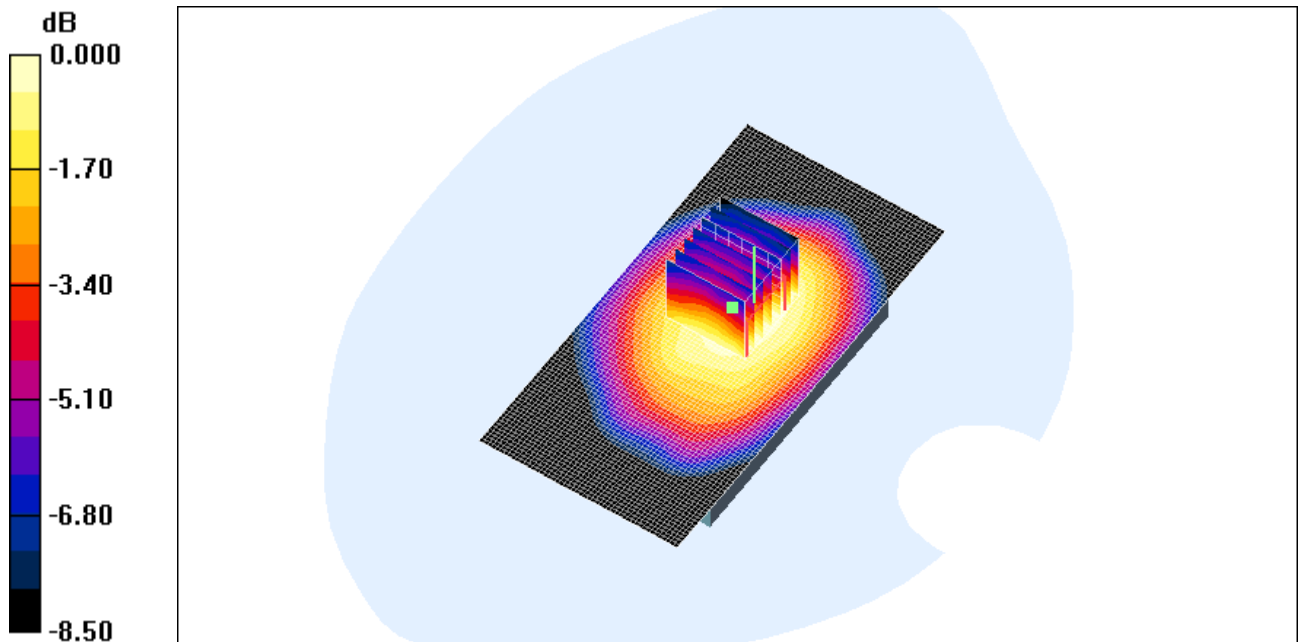
Middle 2/Zoom Scan (7x7x7)/Cube 0: **Measurement grid: dx=5mm, dy=5mm, dz=5mm**

Reference Value = 27.6 V/m; Power Drift = -0.158 dB

Peak SAR (extrapolated) = 1.02 W/kg

SAR(1 g) = 0.796 mW/g; SAR(10 g) = 0.609 mW/g

Maximum value of SAR (measured) = 0.849 mW/g



0 dB = 0.849mW/g

16.5.5 GSM 850+GPRS 3TS-Hotspot body-FrontSide-Middle

Date/Time: 2012-8-7 16:36:57

Test Laboratory: SGS-GSM

R208 GSM 850+GPRS 3TS Hotspot body Front Middle

DUT: R208; Type: GSM/WCDMA/WIFI; Serial: 866322010006055

Communication System: GSM850-GPRS Mode(3up); Frequency: 836.6 MHz;Duty Cycle: 1:2.77

Medium: HSL835_Body Medium parameters used: f = 836.6 MHz; $\sigma = 0.99$ mho/m; $\epsilon_r = 56.5$; $\rho = 1000$ kg/m³

Phantom section: Flat Section

DASY4 Configuration:

- Probe: ES3DV3 - SN3088; ConvF(6.13, 6.13, 6.13); Calibrated: 2011-11-23
- Sensor-Surface: 4mm (Mechanical Surface Detection)
- Electronics: DAE3 Sn569; Calibrated: 2011-11-16
- Phantom: SAM 12; Type: SAM V4.0; Serial: TP-1283
- Measurement SW: DASY4, V4.7 Build 80; Postprocessing SW: SEMCAD, V1.8 Build 186

Middle/Area Scan (51x101x1): **Measurement grid: dx=15mm, dy=15mm**

Maximum value of SAR (interpolated) = 0.906 mW/g

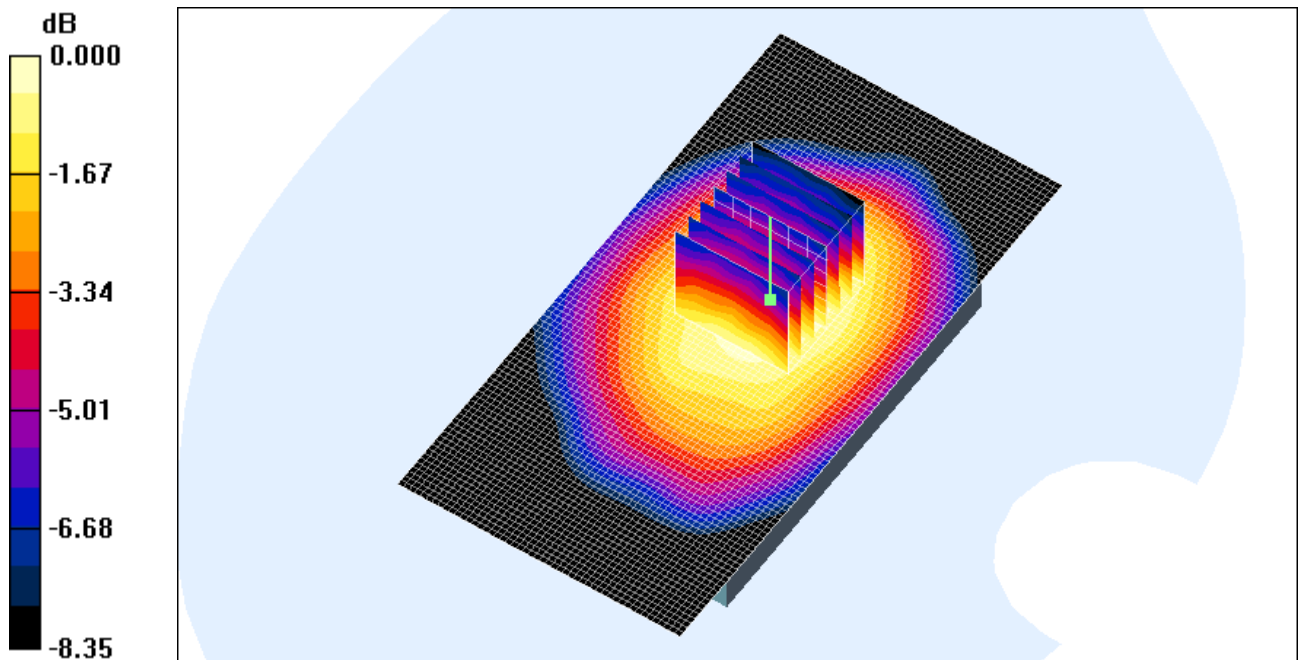
Middle/Zoom Scan (7x7x7)/Cube 0: **Measurement grid: dx=5mm, dy=5mm, dz=5mm**

Reference Value = 29.1 V/m; Power Drift = -0.140 dB

Peak SAR (extrapolated) = 1.05 W/kg

SAR(1 g) = 0.849 mW/g; SAR(10 g) = 0.653 mW/g

Maximum value of SAR (measured) = 0.914 mW/g



0 dB = 0.914mW/g

16.5.6 GSM 850+GPRS 3TS-Hotspot body-FrontSide-High

Date/Time: 2012-8-7 17:02:54

Test Laboratory: SGS-GSM

R208 GSM 850+GPRS 3TS Hotspot body Front High

DUT: R208; Type: GSM/WCDMA/WIFI; Serial: 866322010006055

Communication System: GSM850-GPRS Mode(3up); Frequency: 848.8 MHz;Duty Cycle: 1:2.77

Medium: HSL835_Body Medium parameters used: f = 848.8 MHz; $\sigma = 1$ mho/m; $\epsilon_r = 56.4$; $\rho = 1000$ kg/m³

Phantom section: Flat Section

DASY4 Configuration:

- Probe: ES3DV3 - SN3088; ConvF(6.13, 6.13, 6.13); Calibrated: 2011-11-23
- Sensor-Surface: 4mm (Mechanical Surface Detection)
- Electronics: DAE3 Sn569; Calibrated: 2011-11-16
- Phantom: SAM 12; Type: SAM V4.0; Serial: TP-1283
- Measurement SW: DASY4, V4.7 Build 80; Postprocessing SW: SEMCAD, V1.8 Build 186

High/Area Scan (51x101x1): **Measurement grid: dx=15mm, dy=15mm**

Maximum value of SAR (interpolated) = 0.888 mW/g

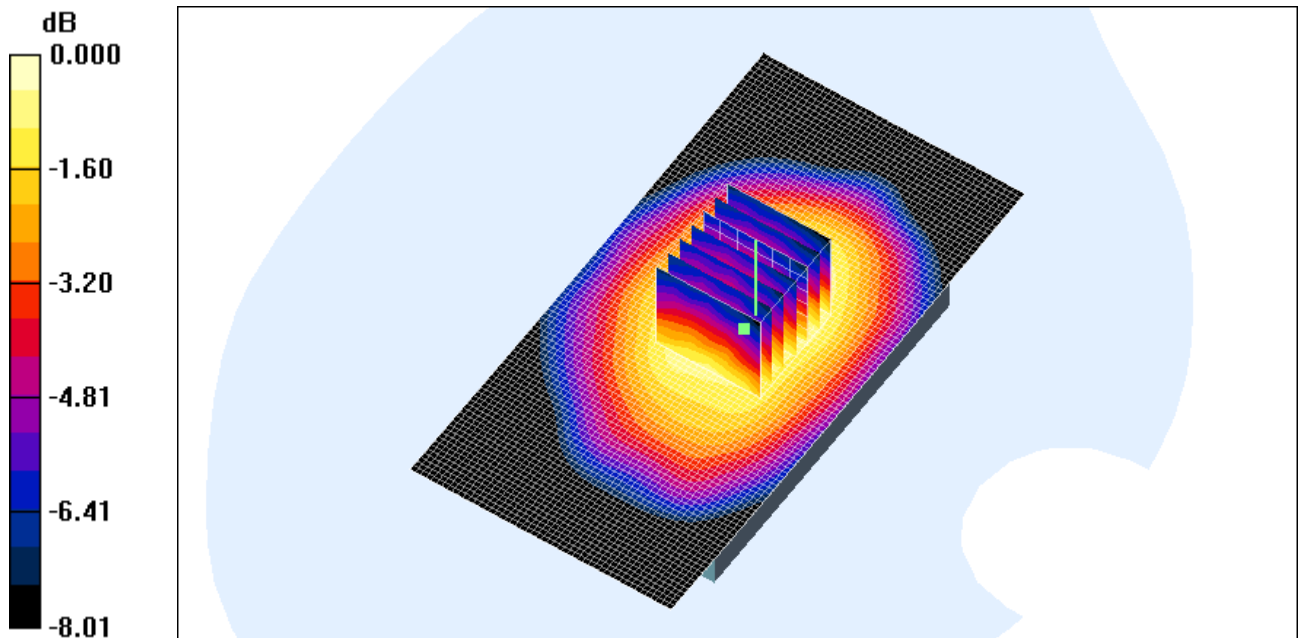
High/Zoom Scan (7x7x7)/Cube 0: **Measurement grid: dx=5mm, dy=5mm, dz=5mm**

Reference Value = 29.1 V/m; Power Drift = -0.0504 dB

Peak SAR (extrapolated) = 1.01 W/kg

SAR(1 g) = 0.835 mW/g; SAR(10 g) = 0.638 mW/g

Maximum value of SAR (measured) = 0.897 mW/g



0 dB = 0.897mW/g

16.5.7 GSM 850+GPRS 3TS-Hotspot body-FrontSide-Low

Date/Time: 2012-8-7 17:26:20

Test Laboratory: SGS-GSM

R208 GSM 850+GPRS 3TS Hotspot body Front Low

DUT: R208; Type: GSM/WCDMA/WIFI; Serial: 866322010006055

Communication System: GSM850-GPRS Mode(3up); Frequency: 824.2 MHz;Duty Cycle: 1:2.77

Medium: HSL835_Body Medium parameters used: f = 824.2 MHz; $\sigma = 0.978$ mho/m; $\epsilon_r = 56.6$; $\rho = 1000$ kg/m³

Phantom section: Flat Section

DASY4 Configuration:

- Probe: ES3DV3 - SN3088; ConvF(6.13, 6.13, 6.13); Calibrated: 2011-11-23
- Sensor-Surface: 4mm (Mechanical Surface Detection)
- Electronics: DAE3 Sn569; Calibrated: 2011-11-16
- Phantom: SAM 12; Type: SAM V4.0; Serial: TP-1283
- Measurement SW: DASY4, V4.7 Build 80; Postprocessing SW: SEMCAD, V1.8 Build 186

Low/Area Scan (51x101x1): **Measurement grid: dx=15mm, dy=15mm**

Maximum value of SAR (interpolated) = 0.869 mW/g

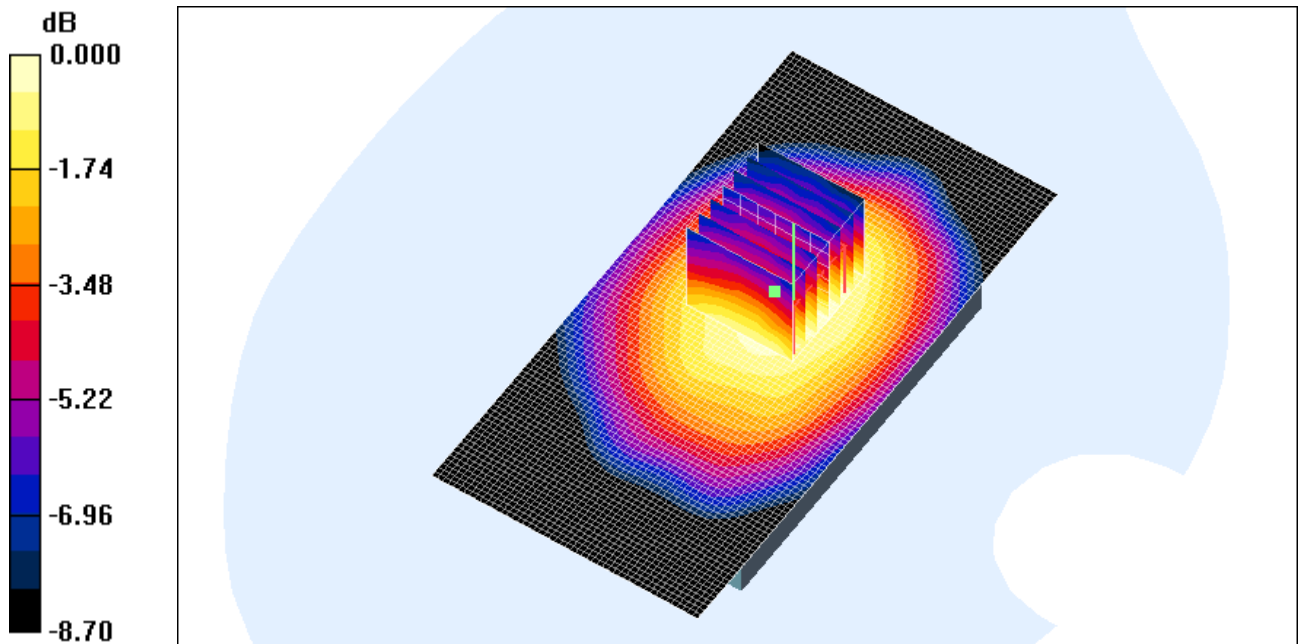
Low/Zoom Scan (7x7x7)/Cube 0: **Measurement grid: dx=5mm, dy=5mm, dz=5mm**

Reference Value = 28.4 V/m; Power Drift = -0.0479 dB

Peak SAR (extrapolated) = 1.01 W/kg

SAR(1 g) = 0.818 mW/g; SAR(10 g) = 0.625 mW/g

Maximum value of SAR (measured) = 0.875 mW/g



0 dB = 0.875mW/g

16.5.8 GSM 850+GPRS 4TS-Hotspot body-FrontSide-Middle

Date/Time: 2012-8-7 17:51:17

Test Laboratory: SGS-GSM

R208 GSM 850+GPRS 4TS Hotspot body Front Middle

DUT: R208; Type: GSM/WCDMA/WIFI; Serial: 866322010006055

Communication System: GSM850-GPRS Mode(4UP); Frequency: 836.6 MHz;Duty Cycle: 1:2.075

Medium: HSL835_Body Medium parameters used: f = 836.6 MHz; $\sigma = 0.99$ mho/m; $\epsilon_r = 56.5$; $\rho = 1000$ kg/m³

Phantom section: Flat Section

DASY4 Configuration:

- Probe: ES3DV3 - SN3088; ConvF(6.13, 6.13, 6.13); Calibrated: 2011-11-23
- Sensor-Surface: 4mm (Mechanical Surface Detection)
- Electronics: DAE3 Sn569; Calibrated: 2011-11-16
- Phantom: SAM 12; Type: SAM V4.0; Serial: TP-1283
- Measurement SW: DASY4, V4.7 Build 80; Postprocessing SW: SEMCAD, V1.8 Build 186

Middle/Area Scan (51x101x1): **Measurement grid: dx=15mm, dy=15mm**

Maximum value of SAR (interpolated) = 0.946 mW/g

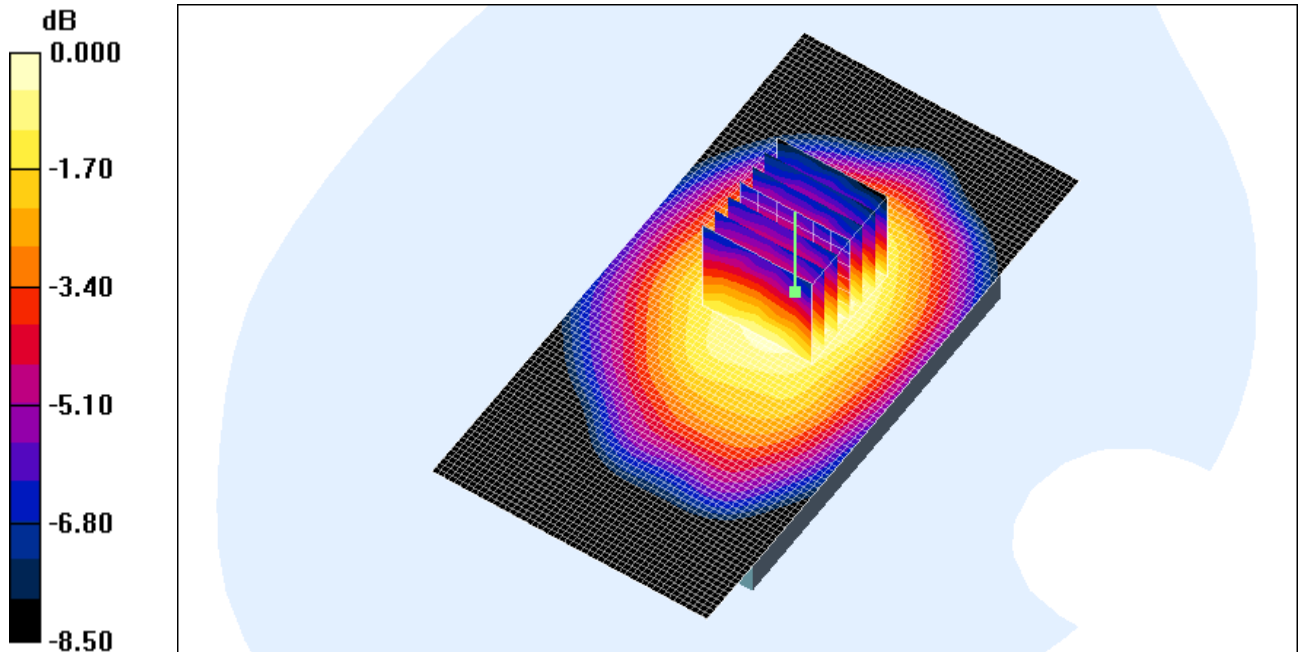
Middle/Zoom Scan (7x7x7)/Cube 0: **Measurement grid: dx=5mm, dy=5mm, dz=5mm**

Reference Value = 29.1 V/m; Power Drift = -0.167 dB

Peak SAR (extrapolated) = 1.13 W/kg

SAR(1 g) = 0.887 mW/g; SAR(10 g) = 0.681 mW/g

Maximum value of SAR (measured) = 0.953 mW/g



0 dB = 0.953mW/g

16.5.9 GSM 850+GPRS 4TS-Hotspot body-FrontSide-High

Date/Time: 2012-8-7 18:15:14

Test Laboratory: SGS-GSM

R208 GSM 850+GPRS 4TS Hotspot body Front High

DUT: R208; Type: GSM/WCDMA/WIFI; Serial: 866322010006055

Communication System: GSM850-GPRS Mode(4UP); Frequency: 848.8 MHz;Duty Cycle: 1:2.075

Medium: HSL835_Body Medium parameters used: f = 848.8 MHz; $\sigma = 1$ mho/m; $\epsilon_r = 56.4$; $\rho = 1000$ kg/m³

Phantom section: Flat Section

DASY4 Configuration:

- Probe: ES3DV3 - SN3088; ConvF(6.13, 6.13, 6.13); Calibrated: 2011-11-23
- Sensor-Surface: 4mm (Mechanical Surface Detection)
- Electronics: DAE3 Sn569; Calibrated: 2011-11-16
- Phantom: SAM 12; Type: SAM V4.0; Serial: TP-1283
- Measurement SW: DASY4, V4.7 Build 80; Postprocessing SW: SEMCAD, V1.8 Build 186

High/Area Scan (51x101x1): **Measurement grid: dx=15mm, dy=15mm**

Maximum value of SAR (interpolated) = 0.934 mW/g

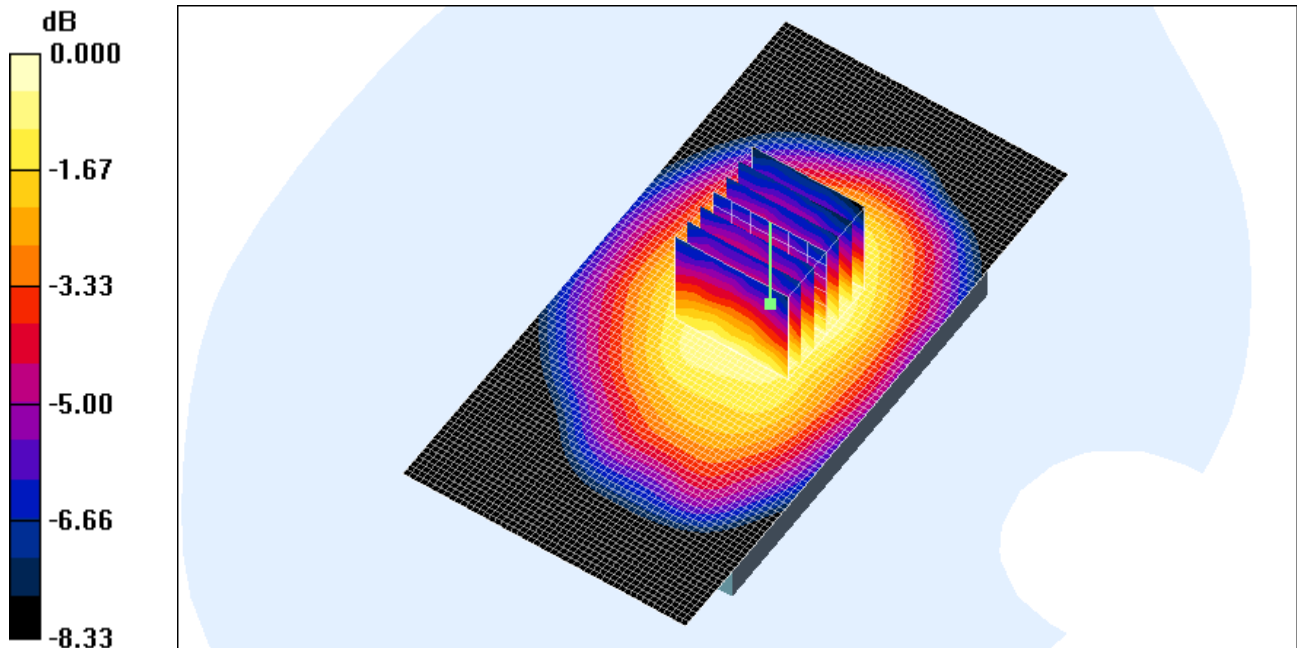
High/Zoom Scan (7x7x7)/Cube 0: **Measurement grid: dx=5mm, dy=5mm, dz=5mm**

Reference Value = 29.7 V/m; Power Drift = -0.0453 dB

Peak SAR (extrapolated) = 1.11 W/kg

SAR(1 g) = 0.880 mW/g; SAR(10 g) = 0.673 mW/g

Maximum value of SAR (measured) = 0.954 mW/g



0 dB = 0.954mW/g

16.5.10 GSM 850+GPRS 4TS-Hotspot body-FrontSide-Low

Date/Time: 2012-8-7 18:39:30

Test Laboratory: SGS-GSM

R208 GSM 850+GPRS 4TS Hotspot body Front Low

DUT: R208; Type: GSM/WCDMA/WIFI; Serial: 866322010006055

Communication System: GSM850-GPRS Mode(4UP); Frequency: 824.2 MHz;Duty Cycle: 1:2.075

Medium: HSL835_Body Medium parameters used: f = 824.2 MHz; $\sigma = 0.978$ mho/m; $\epsilon_r = 56.6$; $\rho = 1000$ kg/m³

Phantom section: Flat Section

DASY4 Configuration:

- Probe: ES3DV3 - SN3088; ConvF(6.13, 6.13, 6.13); Calibrated: 2011-11-23
- Sensor-Surface: 4mm (Mechanical Surface Detection)
- Electronics: DAE3 Sn569; Calibrated: 2011-11-16
- Phantom: SAM 12; Type: SAM V4.0; Serial: TP-1283
- Measurement SW: DASY4, V4.7 Build 80; Postprocessing SW: SEMCAD, V1.8 Build 186

Low/Area Scan (51x101x1): **Measurement grid: dx=15mm, dy=15mm**

Maximum value of SAR (interpolated) = 0.907 mW/g

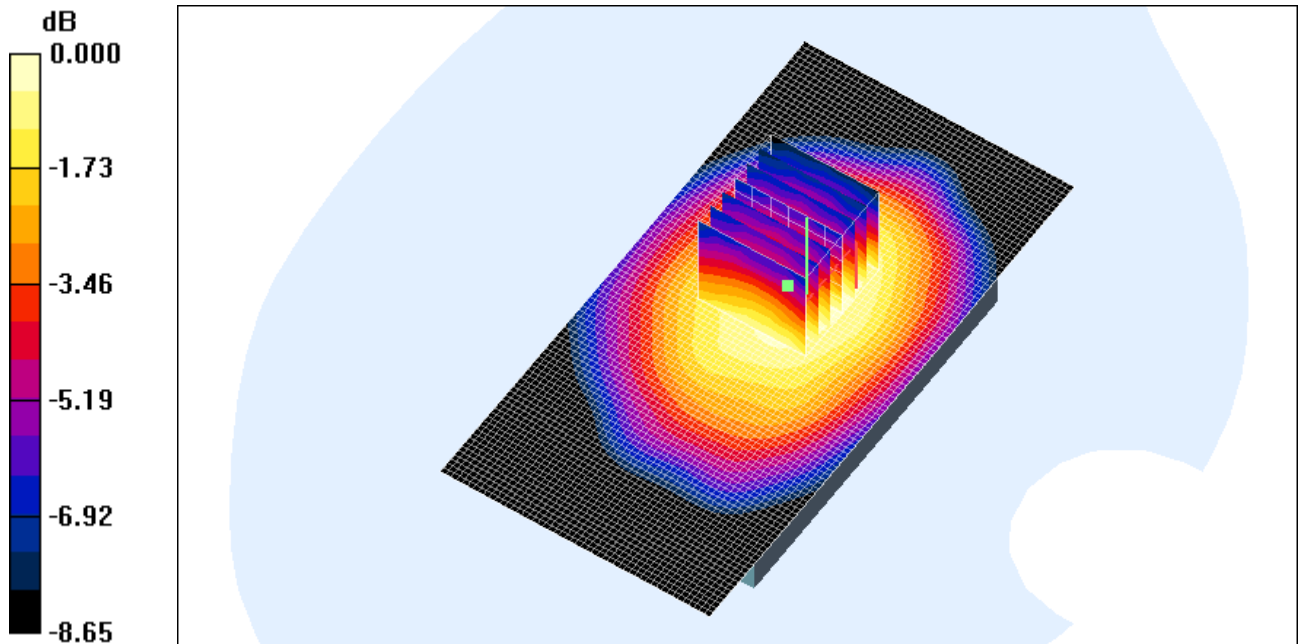
Low/Zoom Scan (7x7x7)/Cube 0: **Measurement grid: dx=5mm, dy=5mm, dz=5mm**

Reference Value = 28.9 V/m; Power Drift = -0.0409 dB

Peak SAR (extrapolated) = 1.03 W/kg

SAR(1 g) = 0.852 mW/g; SAR(10 g) = 0.654 mW/g

Maximum value of SAR (measured) = 0.925 mW/g



0 dB = 0.925mW/g

16.5.11 GSM 850+GPRS 1TS-Hotspot body-BackSide-Middle

Date/Time: 2012-8-7 19:03:21

Test Laboratory: SGS-GSM

R208 GSM 850+GPRS 1TS Hotspot body Back Middle

DUT: R208; Type: GSM/WCDMA/WIFI; Serial: 866322010006055

Communication System: GSM850-GPRS Mode(1up); Frequency: 836.6 MHz;Duty Cycle: 1:8.3

Medium: HSL835_Body Medium parameters used: f = 836.6 MHz; σ = 0.99 mho/m; ϵ_r = 56.5; ρ = 1000 kg/m³

Phantom section: Flat Section

DASY4 Configuration:

- Probe: ES3DV3 - SN3088; ConvF(6.13, 6.13, 6.13); Calibrated: 2011-11-23
- Sensor-Surface: 4mm (Mechanical Surface Detection)
- Electronics: DAE3 Sn569; Calibrated: 2011-11-16
- Phantom: SAM 12; Type: SAM V4.0; Serial: TP-1283
- Measurement SW: DASY4, V4.7 Build 80; Postprocessing SW: SEMCAD, V1.8 Build 186

Middle/Area Scan (51x101x1): **Measurement grid: dx=15mm, dy=15mm**

Maximum value of SAR (interpolated) = 0.986 mW/g

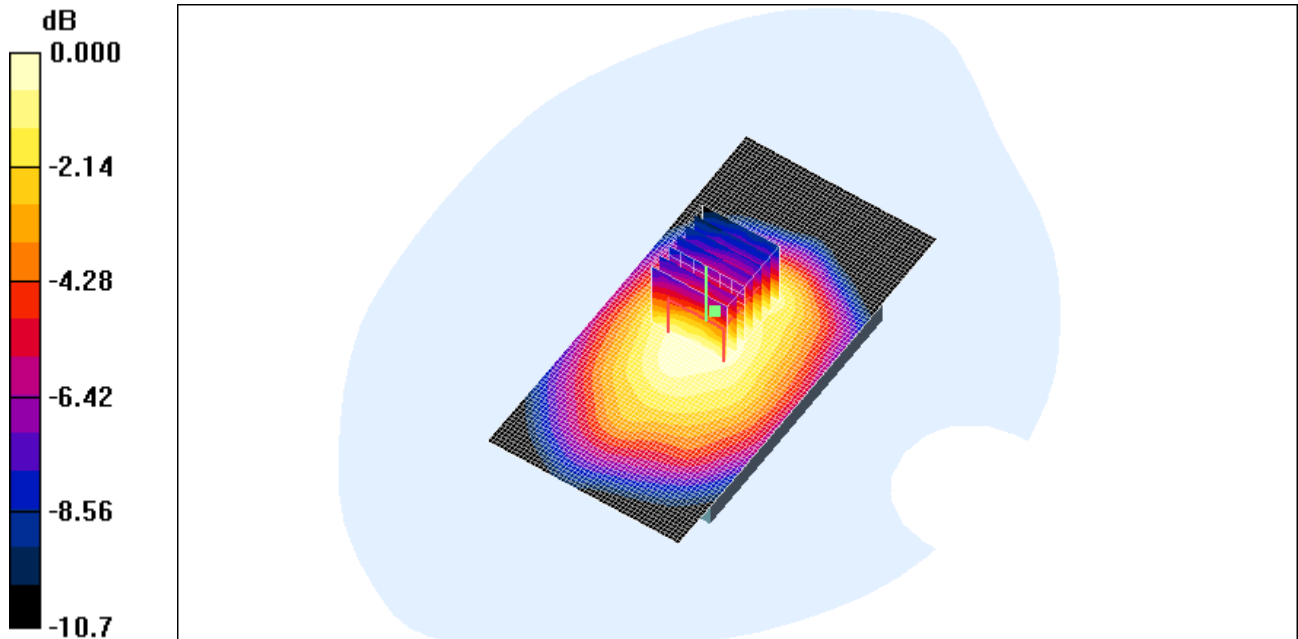
Middle/Zoom Scan (7x7x7)/Cube 0: **Measurement grid: dx=5mm, dy=5mm, dz=5mm**

Reference Value = 31.3 V/m; Power Drift = -0.194 dB

Peak SAR (extrapolated) = 1.23 W/kg

SAR(1 g) = 0.933 mW/g; SAR(10 g) = 0.664 mW/g

Maximum value of SAR (measured) = 1.00 mW/g



0 dB = 1.00mW/g

16.5.12 GSM 850+GPRS 1TS-Hotspot body-BackSide-High

Date/Time: 2012-8-7 19:27:11

Test Laboratory: SGS-GSM

R208 GSM 850+GPRS 1TS Hotspot body Back High

DUT: R208; Type: GSM/WCDMA/WIFI; Serial: 866322010006055

Communication System: GSM850-GPRS Mode(1up); Frequency: 848.8 MHz; Duty Cycle: 1:8.3

Medium: HSL835_Body Medium parameters used: f = 848.8 MHz; $\sigma = 1$ mho/m; $\epsilon_r = 56.4$; $\rho = 1000$ kg/m³

Phantom section: Flat Section

DASY4 Configuration:

- Probe: ES3DV3 - SN3088; ConvF(6.13, 6.13, 6.13); Calibrated: 2011-11-23
- Sensor-Surface: 4mm (Mechanical Surface Detection)
- Electronics: DAE3 Sn569; Calibrated: 2011-11-16
- Phantom: SAM 12; Type: SAM V4.0; Serial: TP-1283
- Measurement SW: DASY4, V4.7 Build 80; Postprocessing SW: SEMCAD, V1.8 Build 186

High/Area Scan (51x101x1): **Measurement grid: dx=15mm, dy=15mm**

Maximum value of SAR (interpolated) = 1.01 mW/g

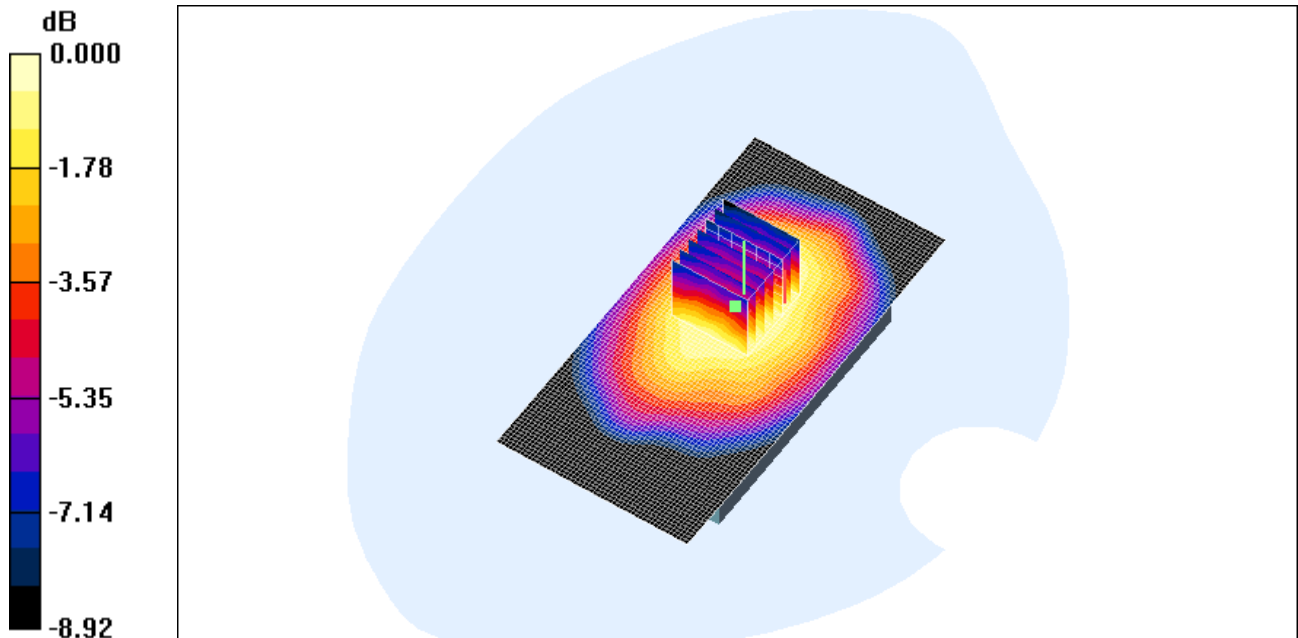
High/Zoom Scan (7x7x7)/Cube 0: **Measurement grid: dx=5mm, dy=5mm, dz=5mm**

Reference Value = 28.5 V/m; Power Drift = -0.121 dB

Peak SAR (extrapolated) = 1.07 W/kg

SAR(1 g) = 0.879 mW/g; SAR(10 g) = 0.670 mW/g

Maximum value of SAR (measured) = 0.958 mW/g



0 dB = 0.958mW/g

16.5.13 GSM 850+GPRS 1TS-Hotspot body-BackSide-Low

Date/Time: 2012-8-7 19:51:55

Test Laboratory: SGS-GSM

R208 GSM 850+GPRS 1TS Hotspot body Back Low

DUT: R208; Type: GSM/WCDMA/WIFI; Serial: 866322010006055

Communication System: GSM850-GPRS Mode(1up); Frequency: 824.2 MHz;Duty Cycle: 1:8.3

Medium: HSL835_Body Medium parameters used: f = 824.2 MHz; $\sigma = 0.978$ mho/m; $\epsilon_r = 56.6$; $\rho = 1000$ kg/m³

Phantom section: Flat Section

DASY4 Configuration:

- Probe: ES3DV3 - SN3088; ConvF(6.13, 6.13, 6.13); Calibrated: 2011-11-23
- Sensor-Surface: 4mm (Mechanical Surface Detection)
- Electronics: DAE3 Sn569; Calibrated: 2011-11-16
- Phantom: SAM 12; Type: SAM V4.0; Serial: TP-1283
- Measurement SW: DASY4, V4.7 Build 80; Postprocessing SW: SEMCAD, V1.8 Build 186

Low/Area Scan (51x101x1): **Measurement grid: dx=15mm, dy=15mm**

Maximum value of SAR (interpolated) = 0.873 mW/g

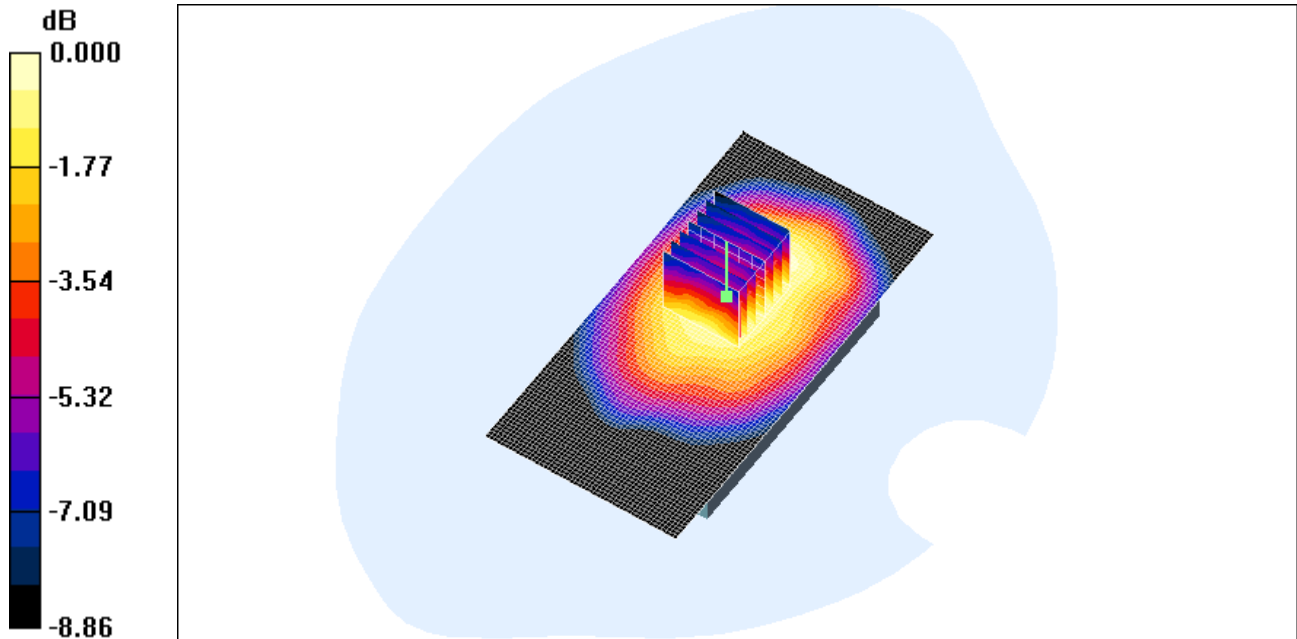
Low/Zoom Scan (7x7x7)/Cube 0: **Measurement grid: dx=5mm, dy=5mm, dz=5mm**

Reference Value = 26.7 V/m; Power Drift = -0.185 dB

Peak SAR (extrapolated) = 0.979 W/kg

SAR(1 g) = 0.769 mW/g; SAR(10 g) = 0.580 mW/g

Maximum value of SAR (measured) = 0.839 mW/g



0 dB = 0.839mW/g

16.5.14 GSM 850+GPRS 1TS-Hotspot body-TopSide-Middle

Date/Time: 2012-8-7 20:15:25

Test Laboratory: SGS-GSM

R208 GSM 850 +GPRS 1TS Hotspot body Top Middle

DUT: R208; Type: GSM/WCDMA/WIFI; Serial: 866322010006055

Communication System: GSM850-GPRS Mode(1up); Frequency: 836.6 MHz; Duty Cycle: 1:8.3

Medium: HSL835_Body Medium parameters used: f = 836.6 MHz; σ = 0.99 mho/m; ϵ_r = 56.5; ρ = 1000 kg/m³

Phantom section: Flat Section

DASY4 Configuration:

- Probe: ES3DV3 - SN3088; ConvF(6.13, 6.13, 6.13); Calibrated: 2011-11-23
- Sensor-Surface: 4mm (Mechanical Surface Detection)
- Electronics: DAE3 Sn569; Calibrated: 2011-11-16
- Phantom: SAM 12; Type: SAM V4.0; Serial: TP-1283
- Measurement SW: DASY4, V4.7 Build 80; Postprocessing SW: SEMCAD, V1.8 Build 186

Middle/Area Scan (51x101x1): **Measurement grid: dx=15mm, dy=15mm**

Maximum value of SAR (interpolated) = 0.487 mW/g

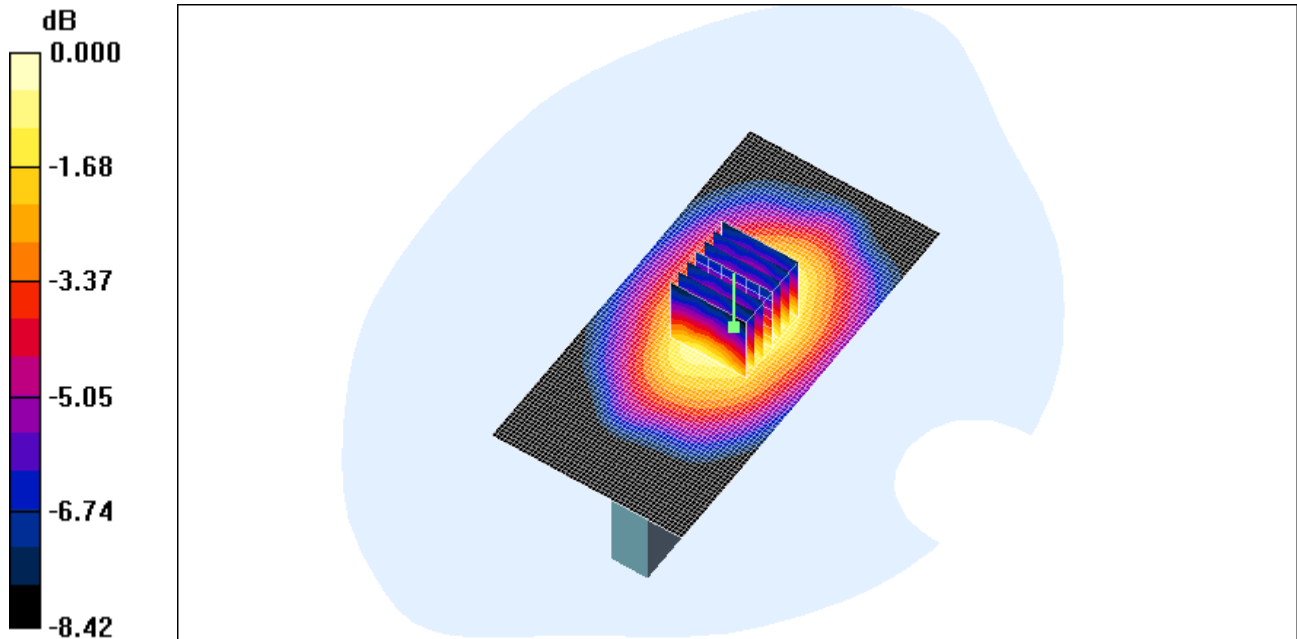
Middle/Zoom Scan (7x7x7)/Cube 0: **Measurement grid: dx=5mm, dy=5mm, dz=5mm**

Reference Value = 21.5 V/m; Power Drift = -0.152 dB

Peak SAR (extrapolated) = 0.528 W/kg

SAR(1 g) = 0.444 mW/g; SAR(10 g) = 0.329 mW/g

Maximum value of SAR (measured) = 0.489 mW/g



0 dB = 0.489mW/g

16.5.15GSM 850+GPRS 1TS-Hotspot body-BottomSide-Middle

Date/Time: 2012-8-7 20:40:41

Test Laboratory: SGS-GSM

R208 GSM 850 +GPRS 1TS Hotspot body Bottom Middle

DUT: R208; Type: GSM/WCDMA/WIFI; Serial: 866322010006055

Communication System: GSM850-GPRS Mode(1up); Frequency: 836.6 MHz;Duty Cycle: 1:8.3

Medium: HSL835_Body Medium parameters used: f = 836.6 MHz; σ = 0.99 mho/m; ϵ_r = 56.5; ρ = 1000 kg/m³

Phantom section: Flat Section

DASY4 Configuration:

- Probe: ES3DV3 - SN3088; ConvF(6.13, 6.13, 6.13); Calibrated: 2011-11-23
- Sensor-Surface: 4mm (Mechanical Surface Detection)
- Electronics: DAE3 Sn569; Calibrated: 2011-11-16
- Phantom: SAM 12; Type: SAM V4.0; Serial: TP-1283
- Measurement SW: DASY4, V4.7 Build 80; Postprocessing SW: SEMCAD, V1.8 Build 186

Middle/Area Scan (51x101x1): **Measurement grid: dx=15mm, dy=15mm**

Maximum value of SAR (interpolated) = 0.595 mW/g

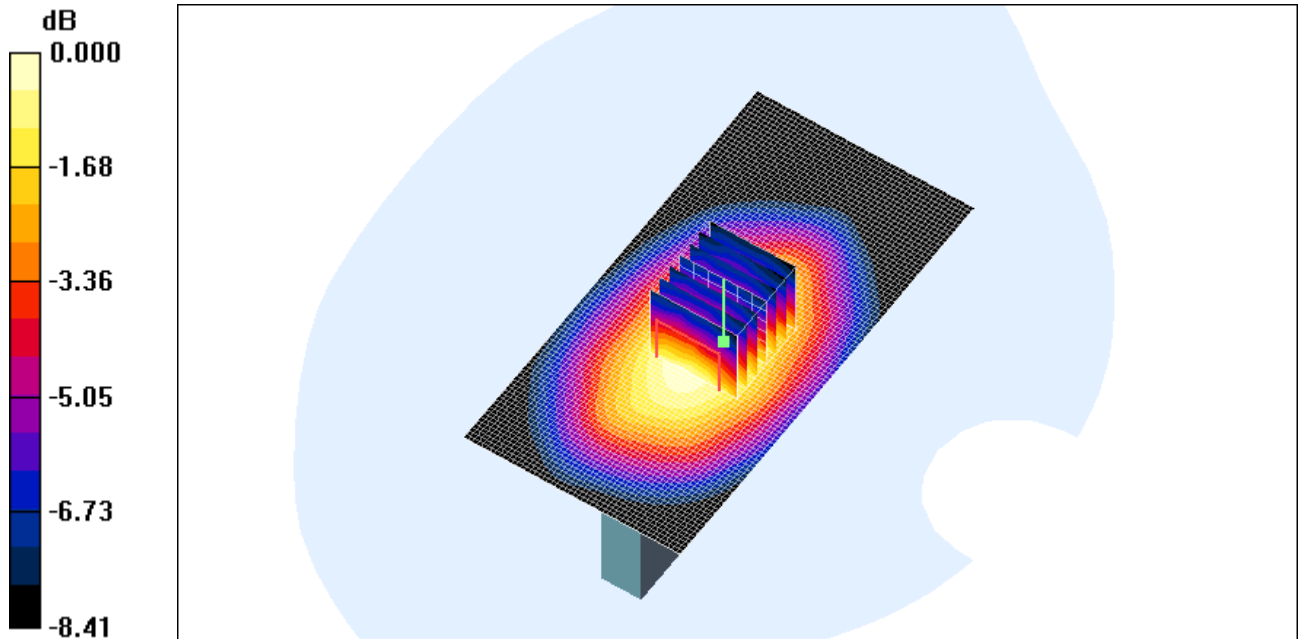
Middle/Zoom Scan (7x7x7)/Cube 0: **Measurement grid: dx=5mm, dy=5mm, dz=5mm**

Reference Value = 23.7 V/m; Power Drift = -0.103 dB

Peak SAR (extrapolated) = 0.694 W/kg

SAR(1 g) = 0.539 mW/g; SAR(10 g) = 0.396 mW/g

Maximum value of SAR (measured) = 0.585 mW/g



0 dB = 0.585mW/g

16.5.16 GSM 850+GPRS 1TS-Hotspot body-RightSide-Middle

Date/Time: 2012-8-7 21:04:38

Test Laboratory: SGS-GSM

R208 GSM 850 +GPRS 1TS Hotspot body Right Middle

DUT: R208; Type: GSM/WCDMA/WIFI; Serial: 866322010006055

Communication System: GSM850-GPRS Mode(1up); Frequency: 836.6 MHz;Duty Cycle: 1:8.3

Medium: HSL835_Body Medium parameters used: f = 836.6 MHz; σ = 0.99 mho/m; ϵ_r = 56.5; ρ = 1000 kg/m³

Phantom section: Flat Section

DASY4 Configuration:

- Probe: ES3DV3 - SN3088; ConvF(6.13, 6.13, 6.13); Calibrated: 2011-11-23
- Sensor-Surface: 4mm (Mechanical Surface Detection)
- Electronics: DAE3 Sn569; Calibrated: 2011-11-16
- Phantom: SAM 12; Type: SAM V4.0; Serial: TP-1283
- Measurement SW: DASY4, V4.7 Build 80; Postprocessing SW: SEMCAD, V1.8 Build 186

Middle/Area Scan (51x101x1): **Measurement grid: dx=15mm, dy=15mm**

Maximum value of SAR (interpolated) = 0.160 mW/g

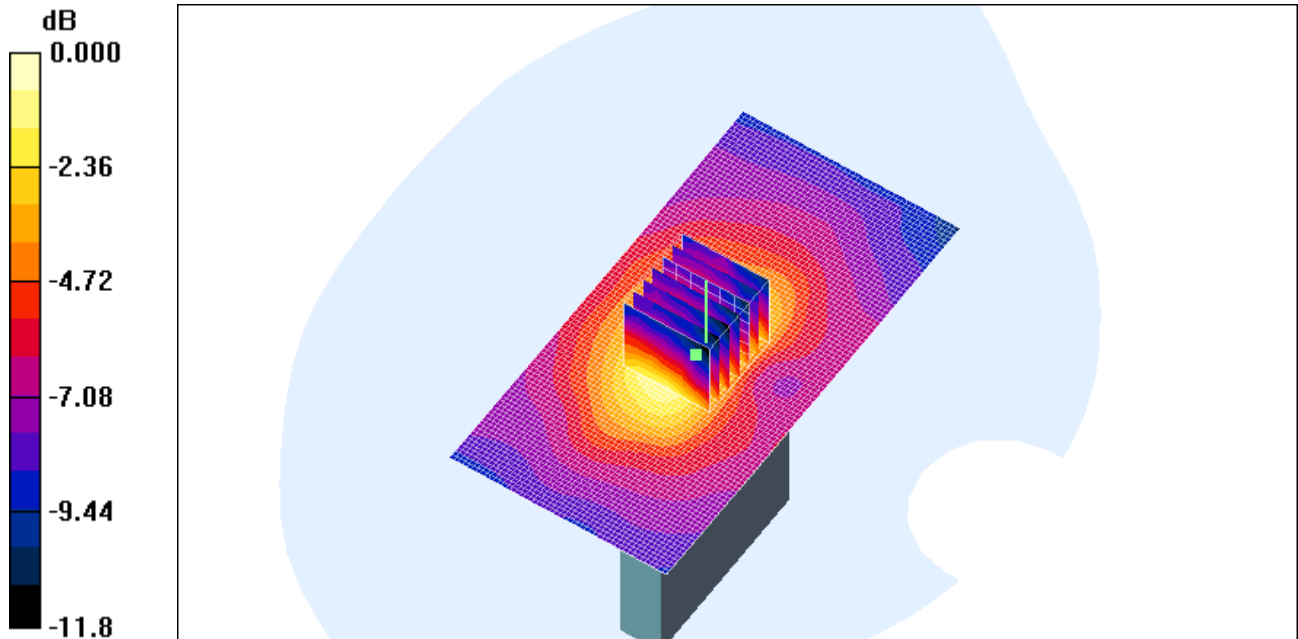
Middle/Zoom Scan (7x7x7)/Cube 0: **Measurement grid: dx=5mm, dy=5mm, dz=5mm**

Reference Value = 13.0 V/m; Power Drift = -0.172 dB

Peak SAR (extrapolated) = 0.189 W/kg

SAR(1 g) = 0.137 mW/g; SAR(10 g) = 0.091 mW/g

Maximum value of SAR (measured) = 0.155 mW/g



0 dB = 0.155mW/g

16.5.17 GSM 850+EGPRS 1TS-Hotspot body-FrontSide-High

Date/Time: 2012-8-7 21:28:25

Test Laboratory: SGS-GSM

R208 GSM 850+EGPRS 1TS Hotspot body Front High

DUT: R208; Type: GSM/WCDMA/WIFI; Serial: 866322010006055

Communication System: GSM850-EGPRS Mode(1up); Frequency: 848.8 MHz;Duty Cycle: 1:8.3

Medium: HSL835_Body Medium parameters used: f = 848.8 MHz; $\sigma = 1$ mho/m; $\epsilon_r = 56.4$; $\rho = 1000$ kg/m³

Phantom section: Flat Section

DASY4 Configuration:

- Probe: ES3DV3 - SN3088; ConvF(6.13, 6.13, 6.13); Calibrated: 2011-11-23
- Sensor-Surface: 4mm (Mechanical Surface Detection)
- Electronics: DAE3 Sn569; Calibrated: 2011-11-16
- Phantom: SAM 12; Type: SAM V4.0; Serial: TP-1283
- Measurement SW: DASY4, V4.7 Build 80; Postprocessing SW: SEMCAD, V1.8 Build 186

High/Area Scan (51x101x1): **Measurement grid: dx=15mm, dy=15mm**

Maximum value of SAR (interpolated) = 1.04 mW/g

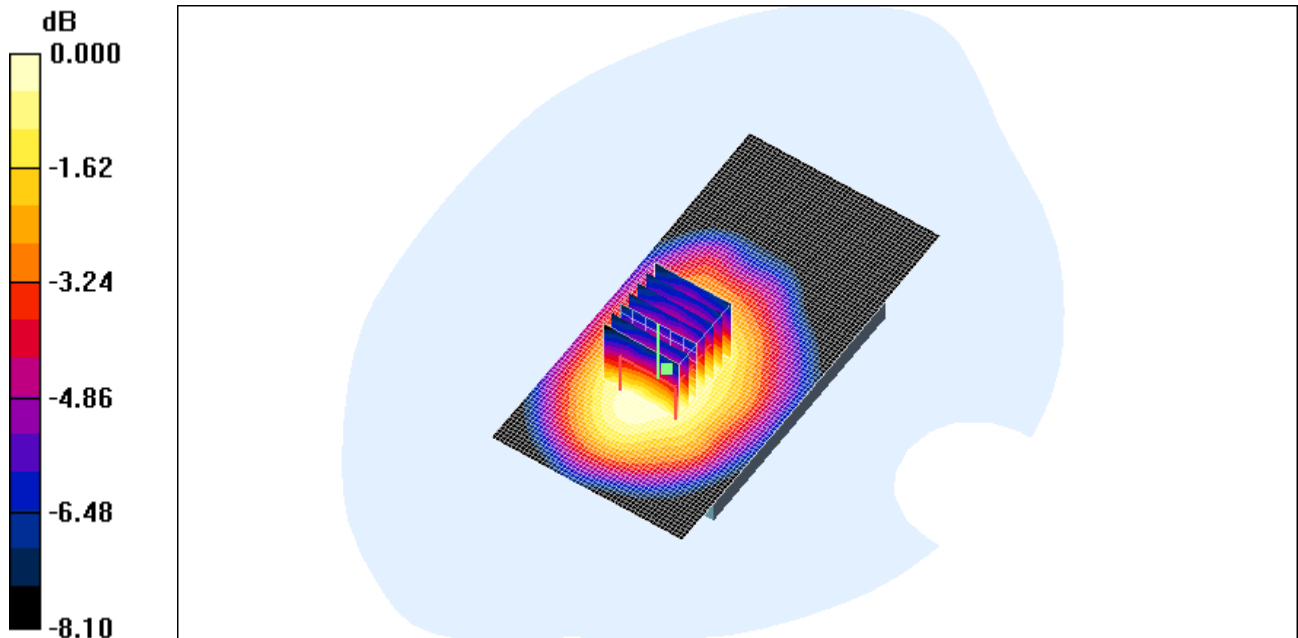
High/Zoom Scan (7x7x7)/Cube 0: **Measurement grid: dx=5mm, dy=5mm, dz=5mm**

Reference Value = 27.8 V/m; Power Drift = -0.136 dB

Peak SAR (extrapolated) = 1.40 W/kg

SAR(1 g) = 0.969 mW/g; SAR(10 g) = 0.729 mW/g

Maximum value of SAR (measured) = 1.05 mW/g



0 dB = 1.05mW/g

16.5.18 GSM 850+EGPRS 2TS-Hotspot body-FrontSide-High

Date/Time: 2012-8-7 21:52:09

Test Laboratory: SGS-GSM

R208 GSM 850+EGPRS 2TS Hotspot body Front High

DUT: R208; Type: GSM/WCDMA/WIFI; Serial: 866322010006055

Communication System: GSM850-EGPRS Mode(2up); Frequency: 848.8 MHz;Duty Cycle: 1:4.15

Medium: HSL835_Body Medium parameters used: f = 848.8 MHz; $\sigma = 1$ mho/m; $\epsilon_r = 56.4$; $\rho = 1000$ kg/m³

Phantom section: Flat Section

DASY4 Configuration:

- Probe: ES3DV3 - SN3088; ConvF(6.13, 6.13, 6.13); Calibrated: 2011-11-23
- Sensor-Surface: 4mm (Mechanical Surface Detection)
- Electronics: DAE3 Sn569; Calibrated: 2011-11-16
- Phantom: SAM 12; Type: SAM V4.0; Serial: TP-1283
- Measurement SW: DASY4, V4.7 Build 80; Postprocessing SW: SEMCAD, V1.8 Build 186

High/Area Scan (51x101x1): **Measurement grid: dx=15mm, dy=15mm**

Maximum value of SAR (interpolated) = 0.827 mW/g

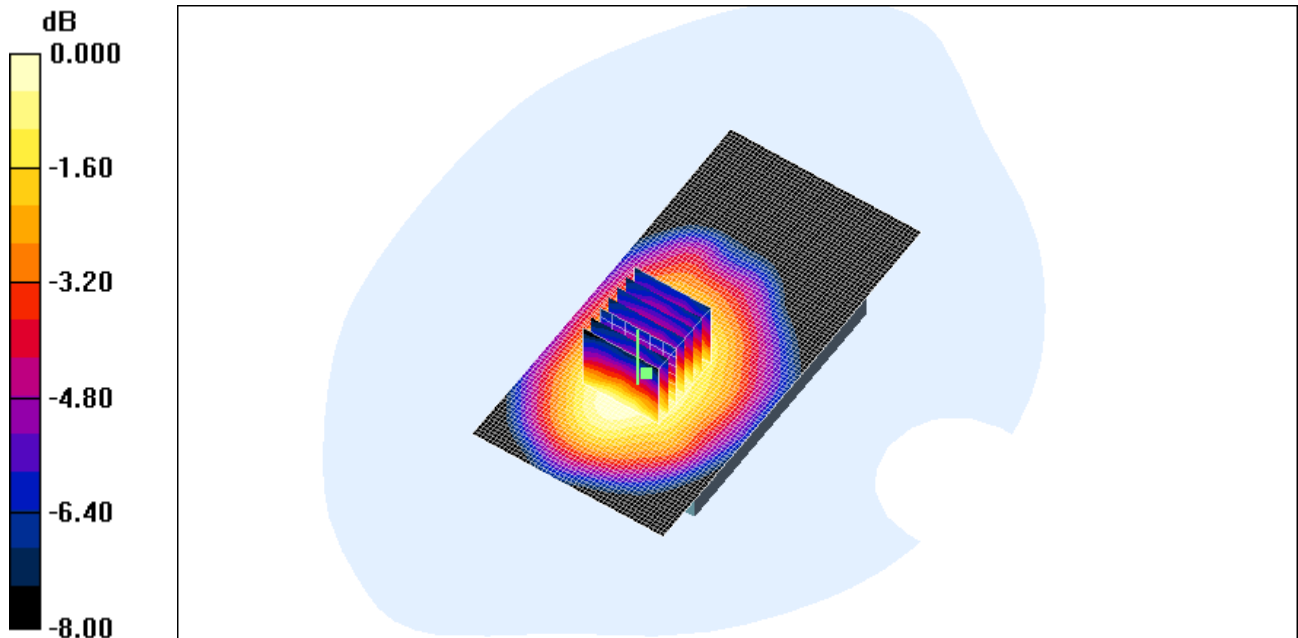
High/Zoom Scan (7x7x7)/Cube 0: **Measurement grid: dx=5mm, dy=5mm, dz=5mm**

Reference Value = 25.1 V/m; Power Drift = -0.169 dB

Peak SAR (extrapolated) = 0.986 W/kg

SAR(1 g) = 0.780 mW/g; SAR(10 g) = 0.596 mW/g

Maximum value of SAR (measured) = 0.844 mW/g



0 dB = 0.844mW/g

16.5.19 GSM 850+EGPRS 3TS-Hotspot body-FrontSide-High

Date/Time: 2012-8-7 22:16:43

Test Laboratory: SGS-GSM

R208 GSM 850+EGPRS 3TS Hotspot body Front High

DUT: R208; Type: GSM/WCDMA/WIFI; Serial: 866322010006055

Communication System: GSM850-EGPRS Mode(3up); Frequency: 848.8 MHz;Duty Cycle: 1:2.77

Medium: HSL835_Body Medium parameters used: f = 848.8 MHz; $\sigma = 1$ mho/m; $\epsilon_r = 56.4$; $\rho = 1000$ kg/m³

Phantom section: Flat Section

DASY4 Configuration:

- Probe: ES3DV3 - SN3088; ConvF(6.13, 6.13, 6.13); Calibrated: 2011-11-23
- Sensor-Surface: 4mm (Mechanical Surface Detection)
- Electronics: DAE3 Sn569; Calibrated: 2011-11-16
- Phantom: SAM 12; Type: SAM V4.0; Serial: TP-1283
- Measurement SW: DASY4, V4.7 Build 80; Postprocessing SW: SEMCAD, V1.8 Build 186

High/Area Scan (51x101x1): **Measurement grid: dx=15mm, dy=15mm**

Maximum value of SAR (interpolated) = 0.896 mW/g

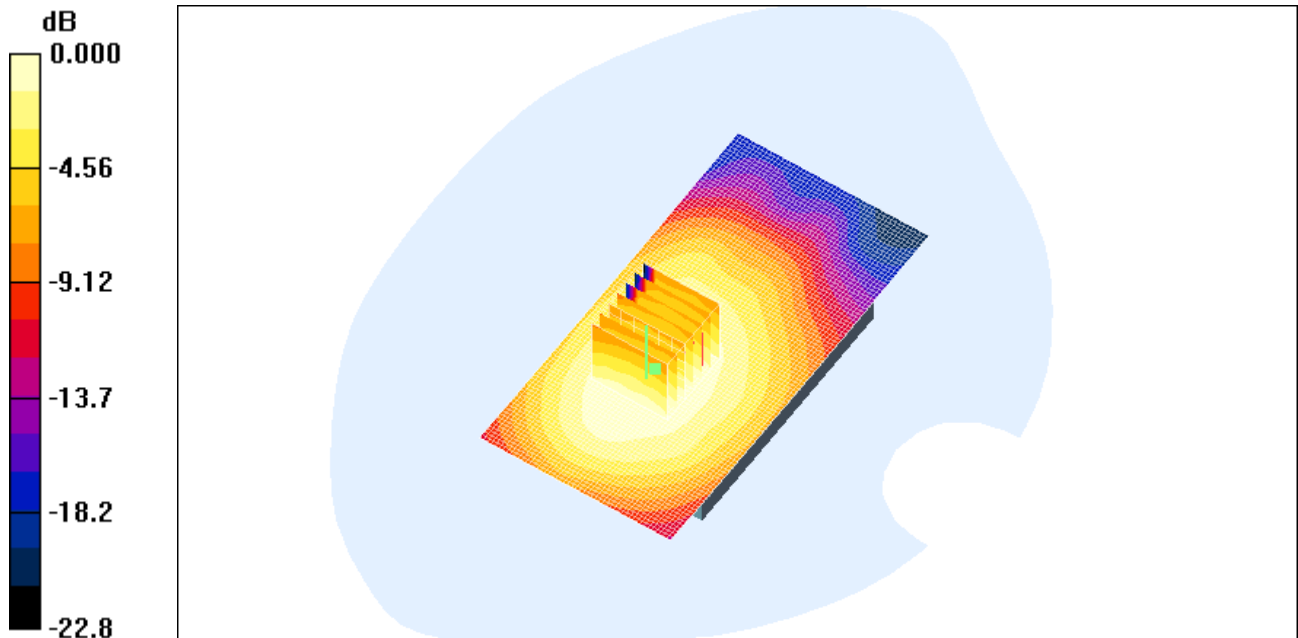
High/Zoom Scan (7x7x7)/Cube 0: **Measurement grid: dx=5mm, dy=5mm, dz=5mm**

Reference Value = 26.1 V/m; Power Drift = 0.102 dB

Peak SAR (extrapolated) = 1.39 W/kg

SAR(1 g) = 0.863 mW/g; SAR(10 g) = 0.654 mW/g

Maximum value of SAR (measured) = 0.909 mW/g



0 dB = 0.909mW/g

16.5.20 GSM 850+EGPRS 4TS-Hotspot body-FrontSide-High

Date/Time: 2012-8-7 22:45:08

Test Laboratory: SGS-GSM

R208 GSM 850+EGPRS 4TS Hotspot body Front High

DUT: R208; Type: GSM/WCDMA/WIFI; Serial: 866322010006055

Communication System: GSM850-EGPRS Mode(4UP); Frequency: 848.8 MHz;Duty Cycle: 1:2.075

Medium: HSL835_Body Medium parameters used: f = 848.8 MHz; $\sigma = 1$ mho/m; $\epsilon_r = 56.4$; $\rho = 1000$ kg/m³

Phantom section: Flat Section

DASY4 Configuration:

- Probe: ES3DV3 - SN3088; ConvF(6.13, 6.13, 6.13); Calibrated: 2011-11-23
- Sensor-Surface: 4mm (Mechanical Surface Detection)
- Electronics: DAE3 Sn569; Calibrated: 2011-11-16
- Phantom: SAM 12; Type: SAM V4.0; Serial: TP-1283
- Measurement SW: DASY4, V4.7 Build 80; Postprocessing SW: SEMCAD, V1.8 Build 186

High/Area Scan (51x101x1): **Measurement grid: dx=15mm, dy=15mm**

Maximum value of SAR (interpolated) = 0.983 mW/g

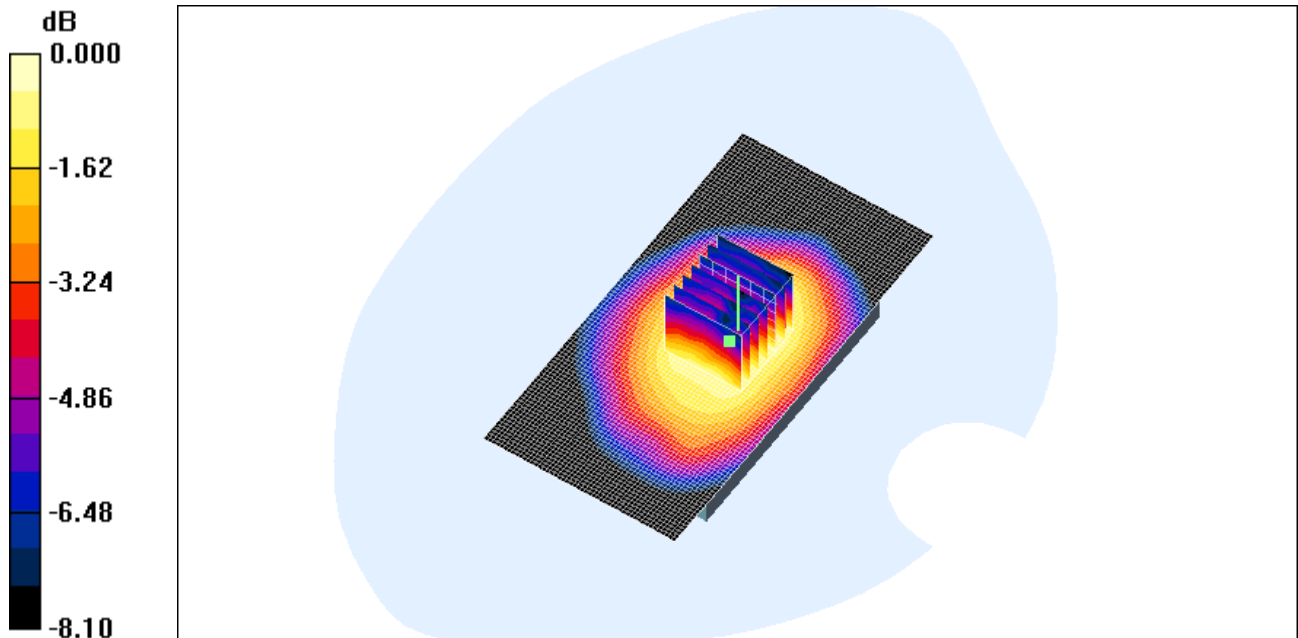
High/Zoom Scan (7x7x7)/Cube 0: **Measurement grid: dx=5mm, dy=5mm, dz=5mm**

Reference Value = 27.0 V/m; Power Drift = 0.162 dB

Peak SAR (extrapolated) = 1.15 W/kg

SAR(1 g) = 0.902 mW/g; SAR(10 g) = 0.679 mW/g

Maximum value of SAR (measured) = 0.974 mW/g



0 dB = 0.974mW/g

16.5.21 GSM 1900+GPRS 1TS-Hotspot body-FrontSide-Middle

Date/Time: 2012-8-6 20:02:29

Test Laboratory: SGS-GSM

R208 GSM 1900-GPRS Mode(1 ts) Hotspot body Front Middle

DUT: R208; Type: GSM/WCDMA/WIFI; Serial: 866322010006055

Communication System: PCS1900-GPRS Mode; Frequency: 1880 MHz;Duty Cycle: 1:8.3

Medium: HSL1900-Body Medium parameters used: $f = 1880$ MHz; $\sigma = 1.58$ mho/m; $\epsilon_r = 50.1$; $\rho = 1000$ kg/m³

Phantom section: Flat Section

DASY4 Configuration:

- Probe: ES3DV3 - SN3088; ConvF(4.8, 4.8, 4.8); Calibrated: 2011-11-23
- Sensor-Surface: 4mm (Mechanical Surface Detection)
- Electronics: DAE3 Sn569; Calibrated: 2011-11-16
- Phantom: SAM 12; Type: SAM V4.0; Serial: TP-1283
- Measurement SW: DASY4, V4.7 Build 80; Postprocessing SW: SEMCAD, V1.8 Build 186

Middle/Area Scan (61x81x1): **Measurement grid: dx=15mm, dy=15mm**

Maximum value of SAR (interpolated) = 0.804 mW/g

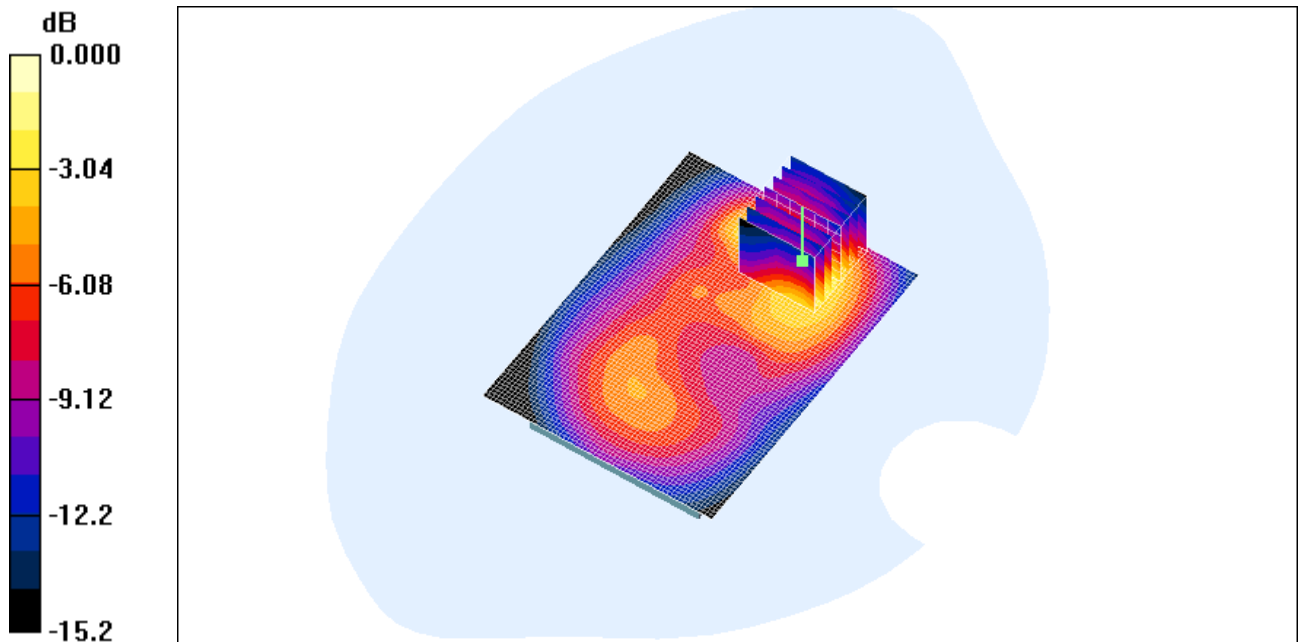
Middle/Zoom Scan (7x7x7)/Cube 0: **Measurement grid: dx=5mm, dy=5mm, dz=5mm**

Reference Value = 9.10 V/m; Power Drift = -0.174 dB

Peak SAR (extrapolated) = 1.05 W/kg

SAR(1 g) = 0.720 mW/g; SAR(10 g) = 0.416 mW/g

Maximum value of SAR (measured) = 0.823 mW/g



0 dB = 0.823mW/g

16.5.22 GSM 1900+GPRS 2TS-Hotspot body-FrontSide-Middle

Date/Time: 2012-8-6 19:43:17

Test Laboratory: SGS-GSM

R208 GSM 1900-GPRS Mode(2 ts) Hotspot body Front Middle

DUT: R208; Type: GSM/WCDMA/WIFI; Serial: 866322010006055

Communication System: PCS1900-GPRS Mode(2 ts); Frequency: 1880 MHz;Duty Cycle: 1:4.15

Medium: HSL1900-Body Medium parameters used: $f = 1880 \text{ MHz}$; $\sigma = 1.58 \text{ mho/m}$; $\epsilon_r = 50.1$; $\rho = 1000 \text{ kg/m}^3$

Phantom section: Flat Section

DASY4 Configuration:

- Probe: ES3DV3 - SN3088; ConvF(4.8, 4.8, 4.8); Calibrated: 2011-11-23
- Sensor-Surface: 4mm (Mechanical Surface Detection)
- Electronics: DAE3 Sn569; Calibrated: 2011-11-16
- Phantom: SAM 12; Type: SAM V4.0; Serial: TP-1283
- Measurement SW: DASY4, V4.7 Build 80; Postprocessing SW: SEMCAD, V1.8 Build 186

Middle/Area Scan (61x81x1): **Measurement grid: $dx=15\text{mm}$, $dy=15\text{mm}$**

Maximum value of SAR (interpolated) = 0.798 mW/g

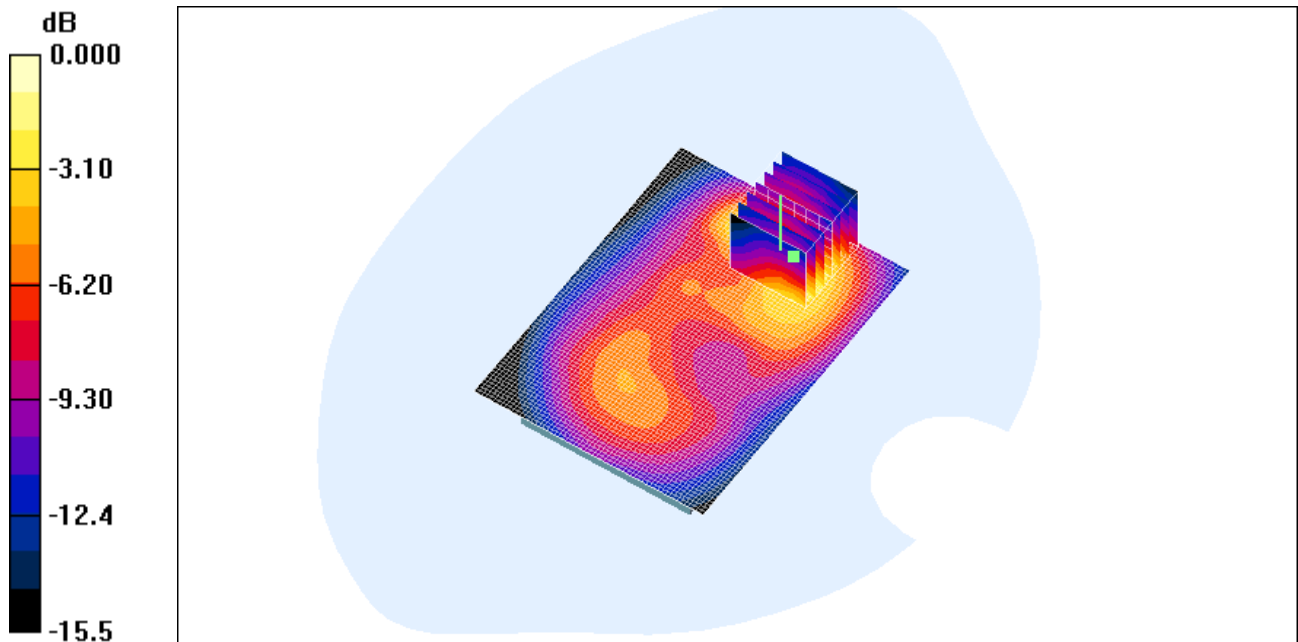
Middle/Zoom Scan (7x7x7)/Cube 0: **Measurement grid: $dx=5\text{mm}$, $dy=5\text{mm}$, $dz=5\text{mm}$**

Reference Value = 9.25 V/m; Power Drift = -0.129 dB

Peak SAR (extrapolated) = 1.03 W/kg

SAR(1 g) = 0.717 mW/g; SAR(10 g) = 0.413 mW/g

Maximum value of SAR (measured) = 0.832 mW/g



0 dB = 0.832mW/g

16.5.23 GSM 1900+GPRS 3TS-Hotspot body-FrontSide-Middle

Date/Time: 2012-8-6 19:24:00

Test Laboratory: SGS-GSM

R208 GSM 1900-GPRS Mode(3 ts) Hotspot body Front Middle

DUT: R208; Type: GSM/WCDMA/WIFI; Serial: 866322010006055

Communication System: PCS1900-GPRS Mode; Frequency: 1880 MHz;Duty Cycle: 1:2.77

Medium: HSL1900-Body Medium parameters used: $f = 1880 \text{ MHz}$; $\sigma = 1.58 \text{ mho/m}$; $\epsilon_r = 50.1$; $\rho = 1000 \text{ kg/m}^3$

Phantom section: Flat Section

DASY4 Configuration:

- Probe: ES3DV3 - SN3088; ConvF(4.8, 4.8, 4.8); Calibrated: 2011-11-23
- Sensor-Surface: 4mm (Mechanical Surface Detection)
- Electronics: DAE3 Sn569; Calibrated: 2011-11-16
- Phantom: SAM 12; Type: SAM V4.0; Serial: TP-1283
- Measurement SW: DASY4, V4.7 Build 80; Postprocessing SW: SEMCAD, V1.8 Build 186

Middle/Area Scan (61x81x1): **Measurement grid: $dx=15\text{mm}$, $dy=15\text{mm}$**

Maximum value of SAR (interpolated) = 0.854 mW/g

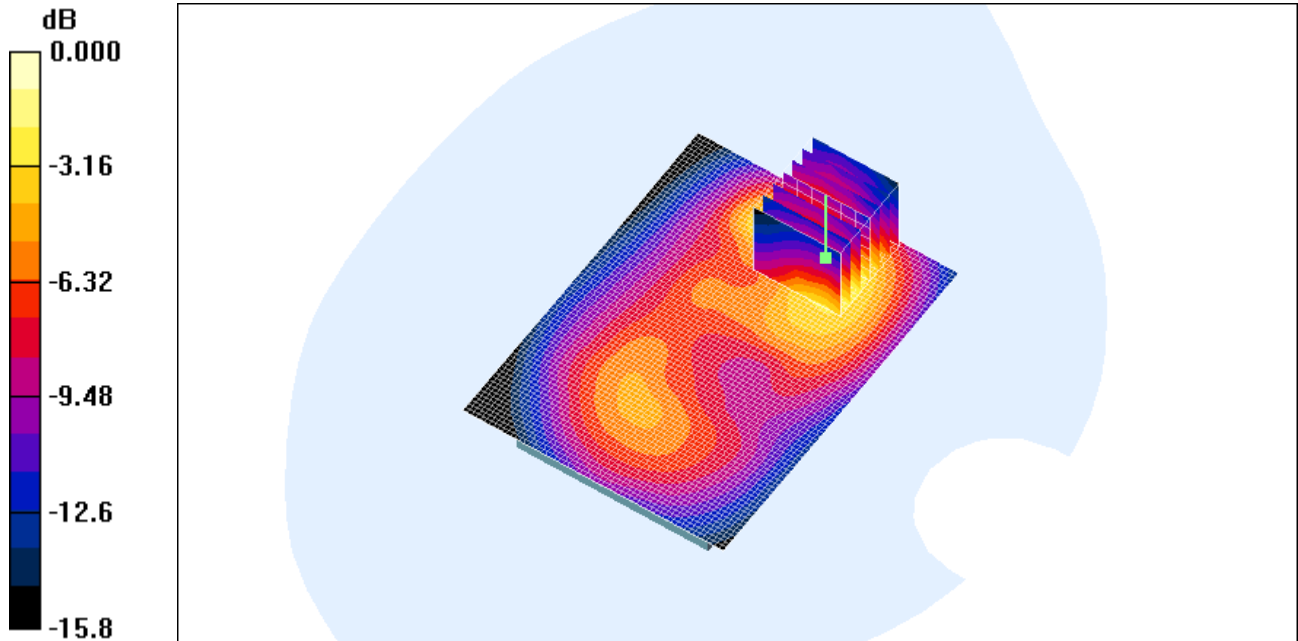
Middle/Zoom Scan (7x7x7)/Cube 0: **Measurement grid: $dx=5\text{mm}$, $dy=5\text{mm}$, $dz=5\text{mm}$**

Reference Value = 9.43 V/m; Power Drift = -0.160 dB

Peak SAR (extrapolated) = 1.17 W/kg

SAR(1 g) = 0.759 mW/g; SAR(10 g) = 0.438 mW/g

Maximum value of SAR (measured) = 0.874 mW/g



0 dB = 0.874mW/g

16.5.24 GSM 1900+GPRS 4TS-Hotspot body-FrontSide-Middle

Date/Time: 2012-8-6 19:01:32

Test Laboratory: SGS-GSM

R208 GSM 1900-GPRS Mode(4 ts) Hotspot body Front Middle

DUT: R208; Type: GSM/WCDMA/WIFI; Serial: 866322010006055

Communication System: PCS1900-GPRS Mode(4 ts); Frequency: 1880 MHz;Duty Cycle: 1:2.075

Medium: HSL1900-Body Medium parameters used: $f = 1880 \text{ MHz}$; $\sigma = 1.58 \text{ mho/m}$; $\epsilon_r = 50.1$; $\rho = 1000 \text{ kg/m}^3$

Phantom section: Flat Section

DASY4 Configuration:

- Probe: ES3DV3 - SN3088; ConvF(4.8, 4.8, 4.8); Calibrated: 2011-11-23
- Sensor-Surface: 4mm (Mechanical Surface Detection)
- Electronics: DAE3 Sn569; Calibrated: 2011-11-16
- Phantom: SAM 12; Type: SAM V4.0; Serial: TP-1283
- Measurement SW: DASY4, V4.7 Build 80; Postprocessing SW: SEMCAD, V1.8 Build 186

Middle/Area Scan (61x81x1): **Measurement grid: $dx=15\text{mm}$, $dy=15\text{mm}$**

Maximum value of SAR (interpolated) = 0.889 mW/g

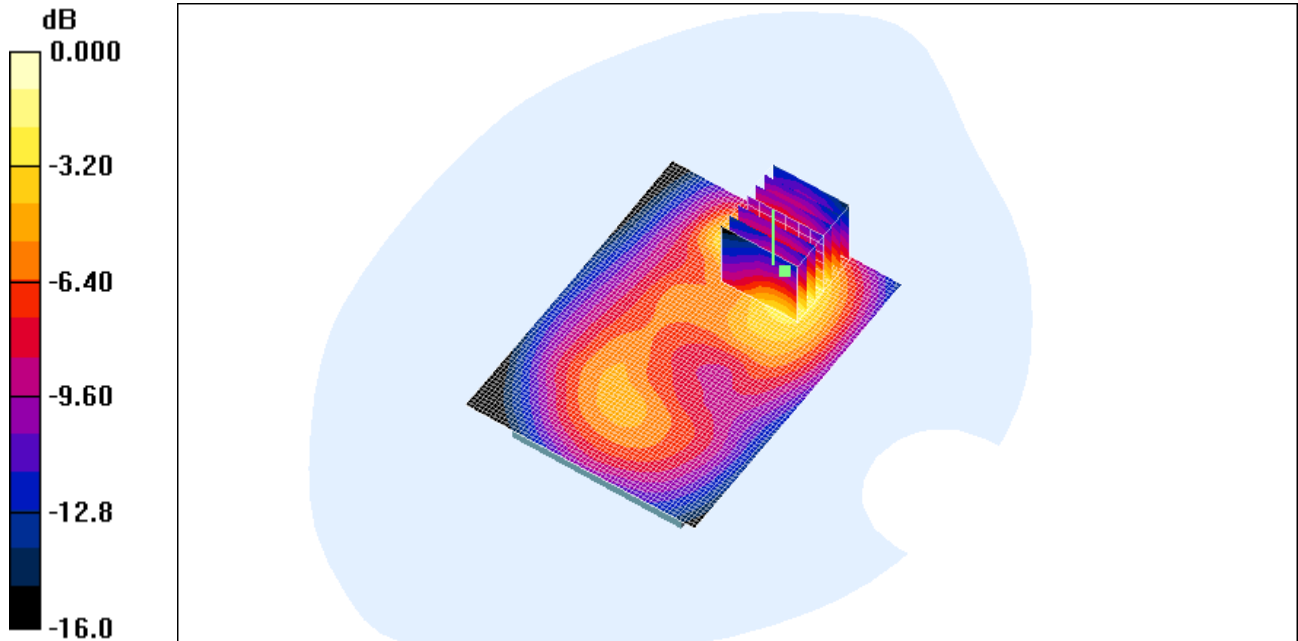
Middle/Zoom Scan (7x7x7)/Cube 0: **Measurement grid: $dx=5\text{mm}$, $dy=5\text{mm}$, $dz=5\text{mm}$**

Reference Value = 9.31 V/m; Power Drift = -0.080 dB

Peak SAR (extrapolated) = 1.12 W/kg

SAR(1 g) = 0.797 mW/g; SAR(10 g) = 0.462 mW/g

Maximum value of SAR (measured) = 0.885 mW/g



0 dB = 0.885mW/g

16.5.25GSM 1900+GPRS 4TS-Hotspot body-BackSide-Middle

Date/Time: 2012-8-6 20:23:26

Test Laboratory: SGS-GSM

R208 GSM 1900-GPRS Mode(4 ts) Hotspot body Back Middle

DUT: R208; Type: GSM/WCDMA/WIFI; Serial: 866322010006055

Communication System: PCS1900-GPRS Mode(4 ts); Frequency: 1880 MHz;Duty Cycle: 1:2.075

Medium: HSL1900-Body Medium parameters used: $f = 1880 \text{ MHz}$; $\sigma = 1.58 \text{ mho/m}$; $\epsilon_r = 50.1$; $\rho = 1000 \text{ kg/m}^3$

Phantom section: Flat Section

DASY4 Configuration:

- Probe: ES3DV3 - SN3088; ConvF(4.8, 4.8, 4.8); Calibrated: 2011-11-23
- Sensor-Surface: 4mm (Mechanical Surface Detection)
- Electronics: DAE3 Sn569; Calibrated: 2011-11-16
- Phantom: SAM 12; Type: SAM V4.0; Serial: TP-1283
- Measurement SW: DASY4, V4.7 Build 80; Postprocessing SW: SEMCAD, V1.8 Build 186

Middle/Area Scan (61x81x1): **Measurement grid: $dx=15\text{mm}$, $dy=15\text{mm}$**

Maximum value of SAR (interpolated) = 0.514 mW/g

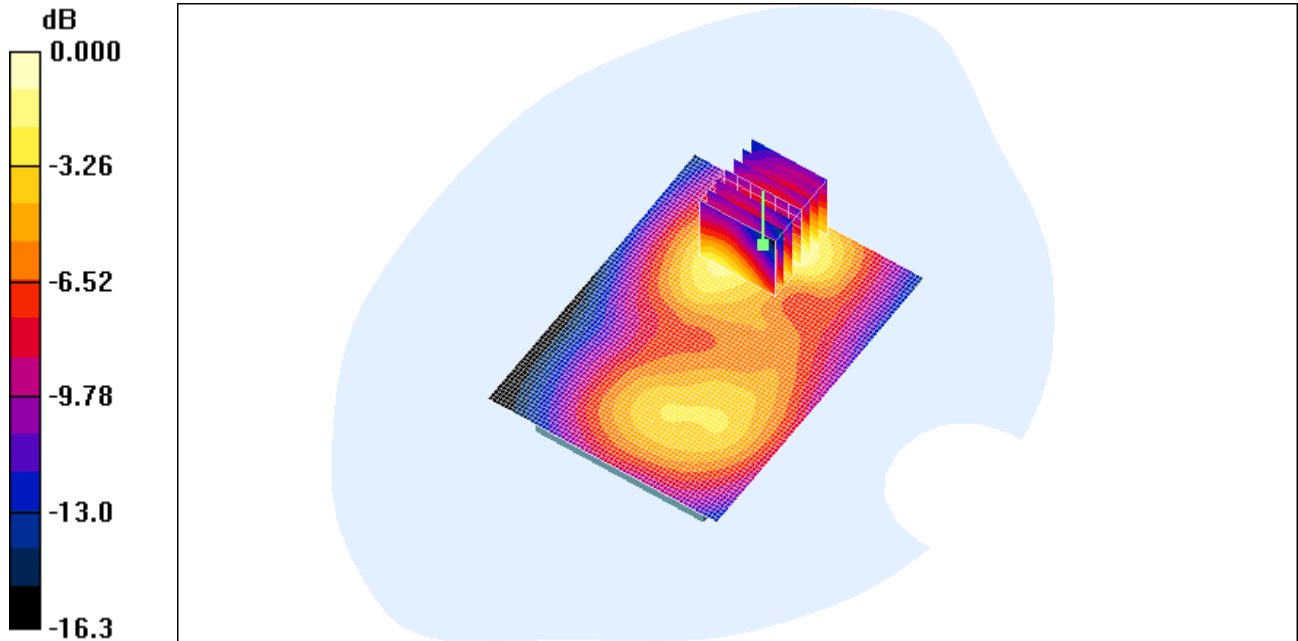
Middle/Zoom Scan (7x7x7)/Cube 0: **Measurement grid: $dx=5\text{mm}$, $dy=5\text{mm}$, $dz=5\text{mm}$**

Reference Value = 8.14 V/m; Power Drift = -0.121 dB

Peak SAR (extrapolated) = 0.701 W/kg

SAR(1 g) = 0.471 mW/g; SAR(10 g) = 0.282 mW/g

Maximum value of SAR (measured) = 0.537 mW/g



0 dB = 0.537mW/g

16.5.26GSM 1900+GPRS 4TS-Hotspot body-TopSide-Middle

Date/Time: 2012-8-6 20:44:21

Test Laboratory: SGS-GSM

R208 GSM 1900 +GPRS 4TS Hotspot body Top Middle

DUT: R208; Type: GSM/WCDMA/WIFI; Serial: 866322010006055

Communication System: PCS1900-GPRS Mode(4 ts); Frequency: 1880 MHz;Duty Cycle: 1:2.075

Medium: HSL1900-Body Medium parameters used: $f = 1880 \text{ MHz}$; $\sigma = 1.58 \text{ mho/m}$; $\epsilon_r = 50.1$; $\rho = 1000 \text{ kg/m}^3$

Phantom section: Flat Section

DASY4 Configuration:

- Probe: ES3DV3 - SN3088; ConvF(4.8, 4.8, 4.8); Calibrated: 2011-11-23
- Sensor-Surface: 4mm (Mechanical Surface Detection)
- Electronics: DAE3 Sn569; Calibrated: 2011-11-16
- Phantom: SAM 12; Type: SAM V4.0; Serial: TP-1283
- Measurement SW: DASY4, V4.7 Build 80; Postprocessing SW: SEMCAD, V1.8 Build 186

Middle/Area Scan (51x101x1): **Measurement grid: $dx=15\text{mm}$, $dy=15\text{mm}$**

Maximum value of SAR (interpolated) = 0.157 mW/g

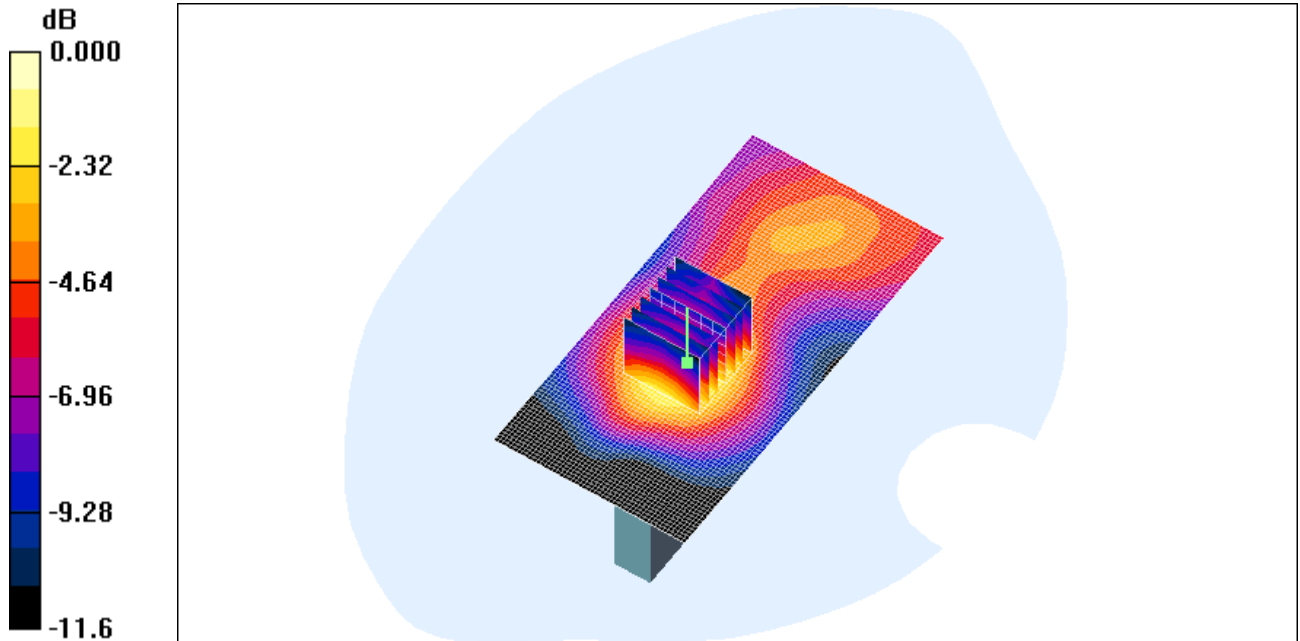
Middle/Zoom Scan (7x7x7)/Cube 0: **Measurement grid: $dx=5\text{mm}$, $dy=5\text{mm}$, $dz=5\text{mm}$**

Reference Value = 8.58 V/m; Power Drift = -0.136 dB

Peak SAR (extrapolated) = 0.183 W/kg

SAR(1 g) = 0.135 mW/g; SAR(10 g) = 0.088 mW/g

Maximum value of SAR (measured) = 0.152 mW/g



0 dB = 0.152mW/g

16.5.27 GSM 1900+GPRS 4TS-Hotspot body-BottomSide-Middle

Date/Time: 2012-8-6 21:05:00

Test Laboratory: SGS-GSM

R208 GSM 1900 +GPRS 4TS Hotspot body Bottom Middle

DUT: R208; Type: GSM/WCDMA/WIFI; Serial: 866322010006055

Communication System: PCS1900-GPRS Mode(4 ts); Frequency: 1880 MHz;Duty Cycle: 1:2.075

Medium: HSL1900-Body Medium parameters used: $f = 1880$ MHz; $\sigma = 1.58$ mho/m; $\epsilon_r = 50.1$; $\rho = 1000$ kg/m³

Phantom section: Flat Section

DASY4 Configuration:

- Probe: ES3DV3 - SN3088; ConvF(4.8, 4.8, 4.8); Calibrated: 2011-11-23
- Sensor-Surface: 4mm (Mechanical Surface Detection)
- Electronics: DAE3 Sn569; Calibrated: 2011-11-16
- Phantom: SAM 12; Type: SAM V4.0; Serial: TP-1283
- Measurement SW: DASY4, V4.7 Build 80; Postprocessing SW: SEMCAD, V1.8 Build 186

Middle/Area Scan (51x101x1): **Measurement grid: dx=15mm, dy=15mm**

Maximum value of SAR (interpolated) = 0.097 mW/g

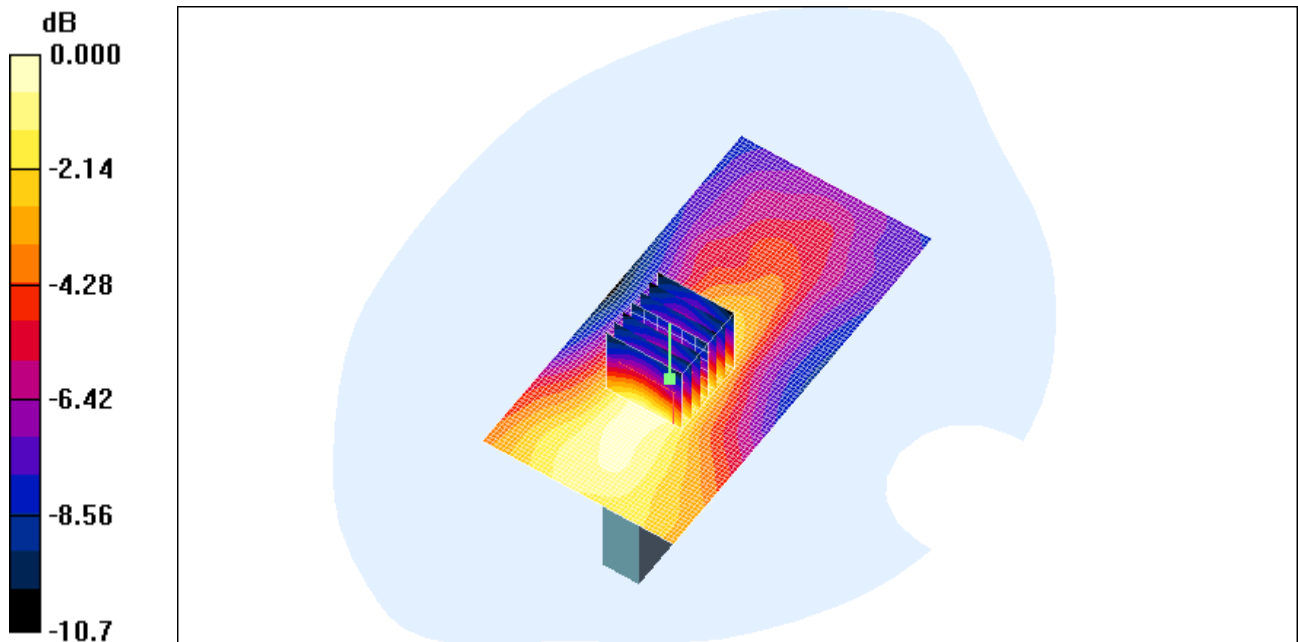
Middle/Zoom Scan (7x7x7)/Cube 0: **Measurement grid: dx=5mm, dy=5mm, dz=5mm**

Reference Value = 6.75 V/m; Power Drift = -0.192 dB

Peak SAR (extrapolated) = 0.121 W/kg

SAR(1 g) = 0.084 mW/g; SAR(10 g) = 0.056 mW/g

Maximum value of SAR (measured) = 0.093 mW/g



0 dB = 0.093mW/g

16.5.28 GSM 1900+GPRS 4TS-Hotspot body-RightSide-Middle

Date/Time: 2012-8-7 8:35:02

Test Laboratory: SGS-GSM

R208 GSM 1900 +GPRS 4TS Hotspot body Right Middle

DUT: R208; Type: GSM/WCDMA/WIFI; Serial: 866322010006055

Communication System: PCS1900-GPRS Mode(4 ts); Frequency: 1880 MHz;Duty Cycle: 1:2.075

Medium: HSL1900-Body Medium parameters used: $f = 1880 \text{ MHz}$; $\sigma = 1.58 \text{ mho/m}$; $\epsilon_r = 50.1$; $\rho = 1000 \text{ kg/m}^3$

Phantom section: Flat Section

DASY4 Configuration:

- Probe: ES3DV3 - SN3088; ConvF(4.8, 4.8, 4.8); Calibrated: 2011-11-23
- Sensor-Surface: 4mm (Mechanical Surface Detection)
- Electronics: DAE3 Sn569; Calibrated: 2011-11-16
- Phantom: SAM 12; Type: SAM V4.0; Serial: TP-1283
- Measurement SW: DASY4, V4.7 Build 80; Postprocessing SW: SEMCAD, V1.8 Build 186

Middle/Area Scan (51x101x1): **Measurement grid: $dx=15\text{mm}$, $dy=15\text{mm}$**

Maximum value of SAR (interpolated) = 1.26 mW/g

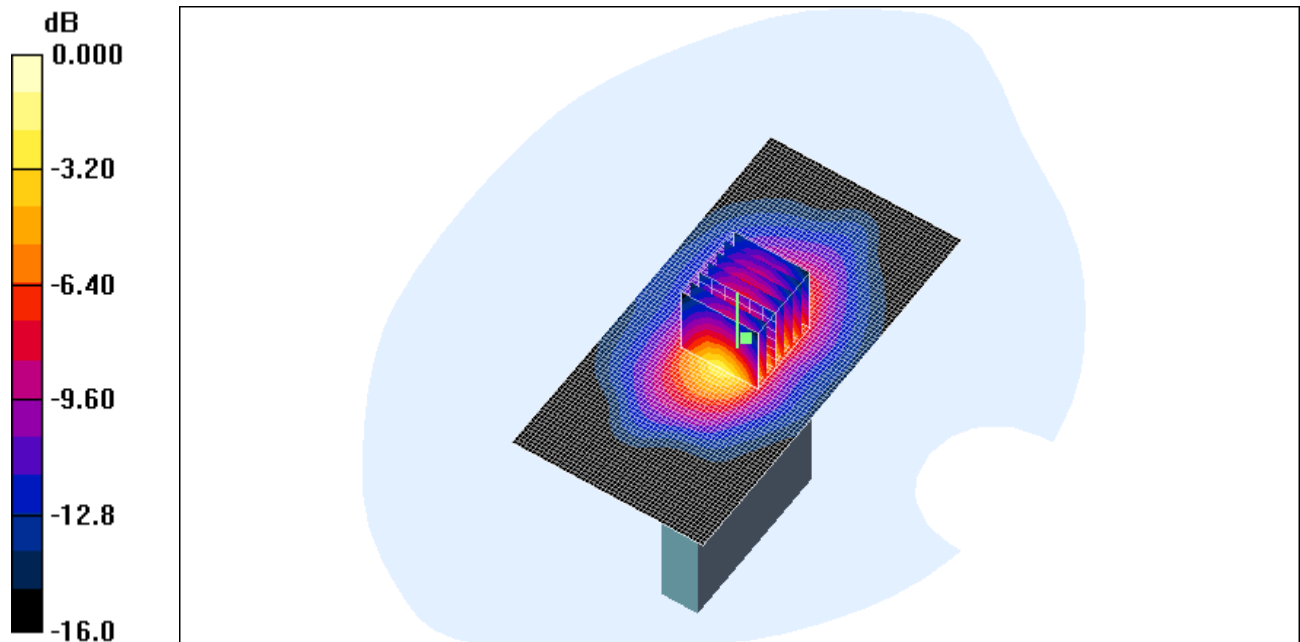
Middle/Zoom Scan (7x7x7)/Cube 0: **Measurement grid: $dx=5\text{mm}$, $dy=5\text{mm}$, $dz=5\text{mm}$**

Reference Value = 28.6 V/m; Power Drift = -0.118 dB

Peak SAR (extrapolated) = 1.68 W/kg

SAR(1 g) = 1.11 mW/g; SAR(10 g) = 0.601 mW/g

Maximum value of SAR (measured) = 1.26 mW/g



0 dB = 1.26mW/g

16.5.29 GSM 1900+GPRS 4TS-Hotspot body-RightSide-High

Date/Time: 2012-8-7 8:58:41

Test Laboratory: SGS-GSM

R208 GSM 1900 +GPRS 4TS Hotspot body Right High

DUT: R208; Type: GSM/WCDMA/WIFI; Serial: 866322010006055

Communication System: PCS1900-GPRS Mode(4 ts); Frequency: 1909.8 MHz;Duty Cycle: 1:2.075

Medium: HSL1900-Body Medium parameters used (interpolated): $f = 1909.8 \text{ MHz}$; $\sigma = 1.61 \text{ mho/m}$; $\epsilon_r = 50$; $\rho = 1000 \text{ kg/m}^3$

Phantom section: Flat Section

DASY4 Configuration:

- Probe: ES3DV3 - SN3088; ConvF(4.8, 4.8, 4.8); Calibrated: 2011-11-23
- Sensor-Surface: 4mm (Mechanical Surface Detection)
- Electronics: DAE3 Sn569; Calibrated: 2011-11-16
- Phantom: SAM 12; Type: SAM V4.0; Serial: TP-1283
- Measurement SW: DASY4, V4.7 Build 80; Postprocessing SW: SEMCAD, V1.8 Build 186

High/Area Scan (51x101x1): **Measurement grid: $dx=15\text{mm}$, $dy=15\text{mm}$**

Maximum value of SAR (interpolated) = 1.36 mW/g

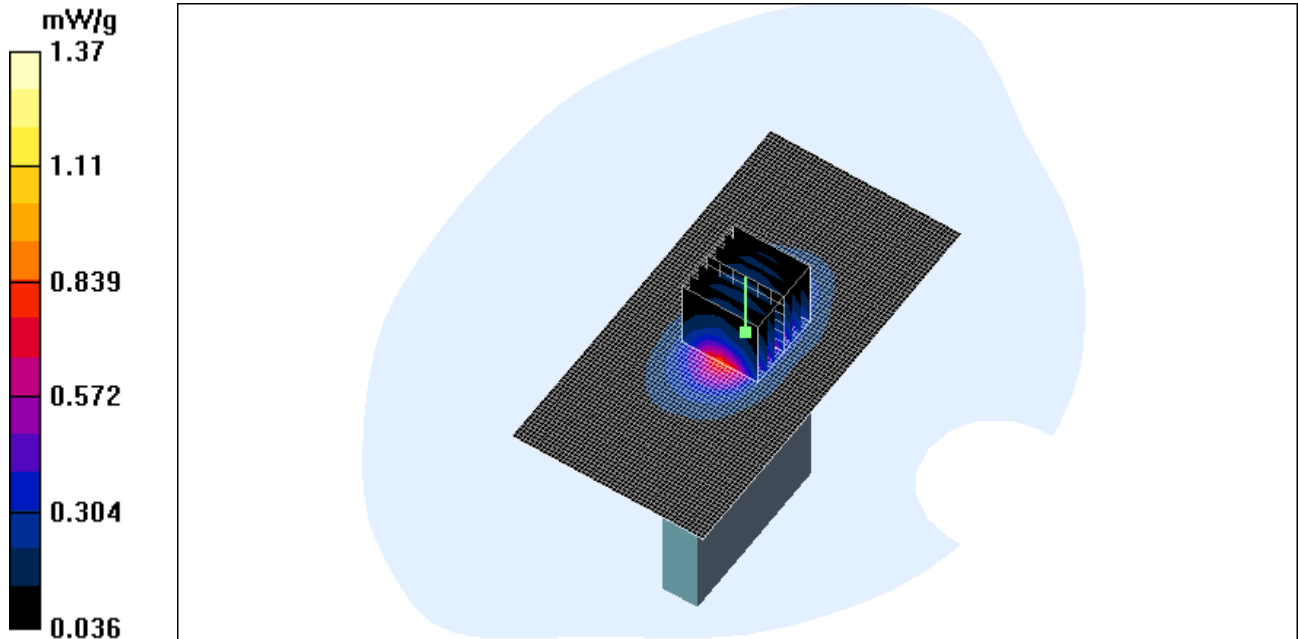
High/Zoom Scan (7x7x7)/Cube 0: **Measurement grid: $dx=5\text{mm}$, $dy=5\text{mm}$, $dz=5\text{mm}$**

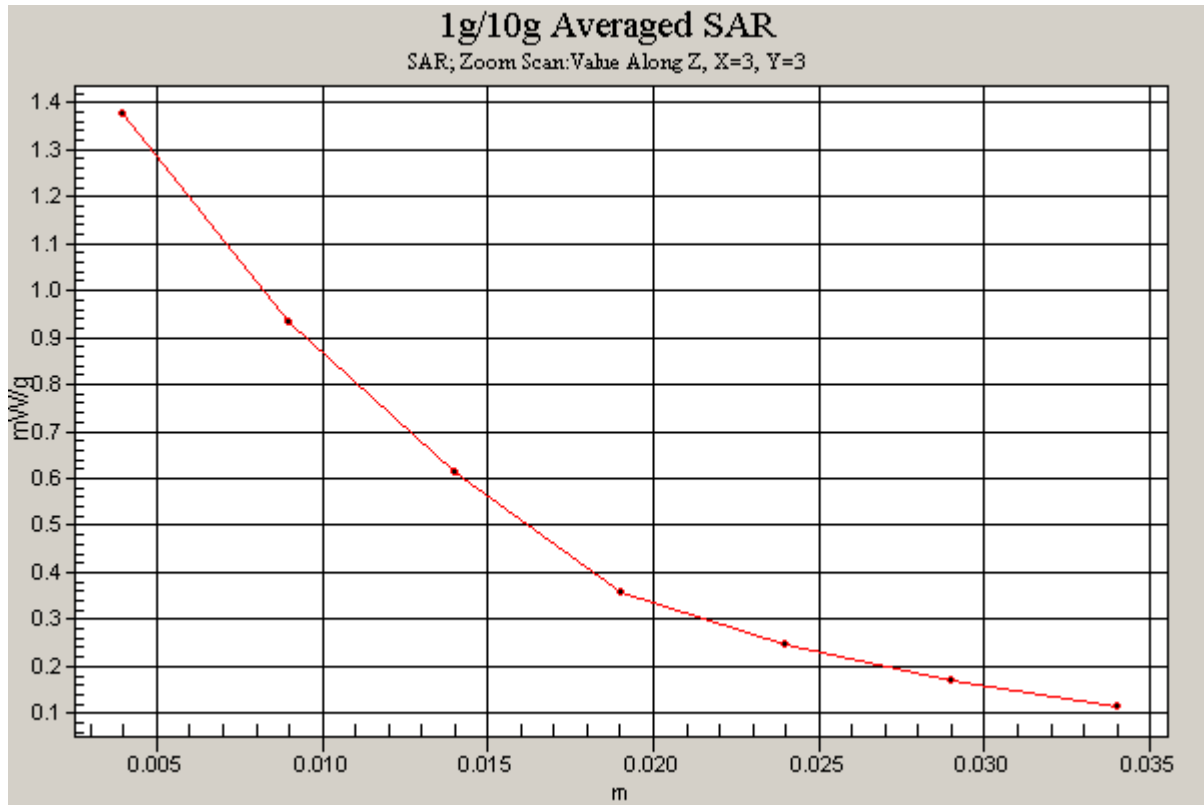
Reference Value = 29.8 V/m; Power Drift = -0.111 dB

Peak SAR (extrapolated) = 1.78 W/kg

SAR(1 g) = 1.19 mW/g; SAR(10 g) = 0.647 mW/g

Maximum value of SAR (measured) = 1.37 mW/g





16.5.30 GSM 1900+GPRS 4TS-Hotspot body-RightSide-Low

Date/Time: 2012-8-7 9:19:37

Test Laboratory: SGS-GSM

R208 GSM 1900 +GPRS 4TS Hotspot body Right Low

DUT: R208; Type: GSM/WCDMA/WIFI; Serial: 866322010006055

Communication System: PCS1900-GPRS Mode(4 ts); Frequency: 1850.2 MHz;Duty Cycle: 1:2.075

Medium: HSL1900-Body Medium parameters used (interpolated): $f = 1850.2 \text{ MHz}$; $\sigma = 1.55 \text{ mho/m}$; $\epsilon_r = 50.2$; $\rho = 1000 \text{ kg/m}^3$

Phantom section: Flat Section

DASY4 Configuration:

- Probe: ES3DV3 - SN3088; ConvF(4.8, 4.8, 4.8); Calibrated: 2011-11-23
- Sensor-Surface: 4mm (Mechanical Surface Detection)
- Electronics: DAE3 Sn569; Calibrated: 2011-11-16
- Phantom: SAM 12; Type: SAM V4.0; Serial: TP-1283
- Measurement SW: DASY4, V4.7 Build 80; Postprocessing SW: SEMCAD, V1.8 Build 186

Low/Area Scan (51x101x1): **Measurement grid: dx=15mm, dy=15mm**

Maximum value of SAR (interpolated) = 1.16 mW/g

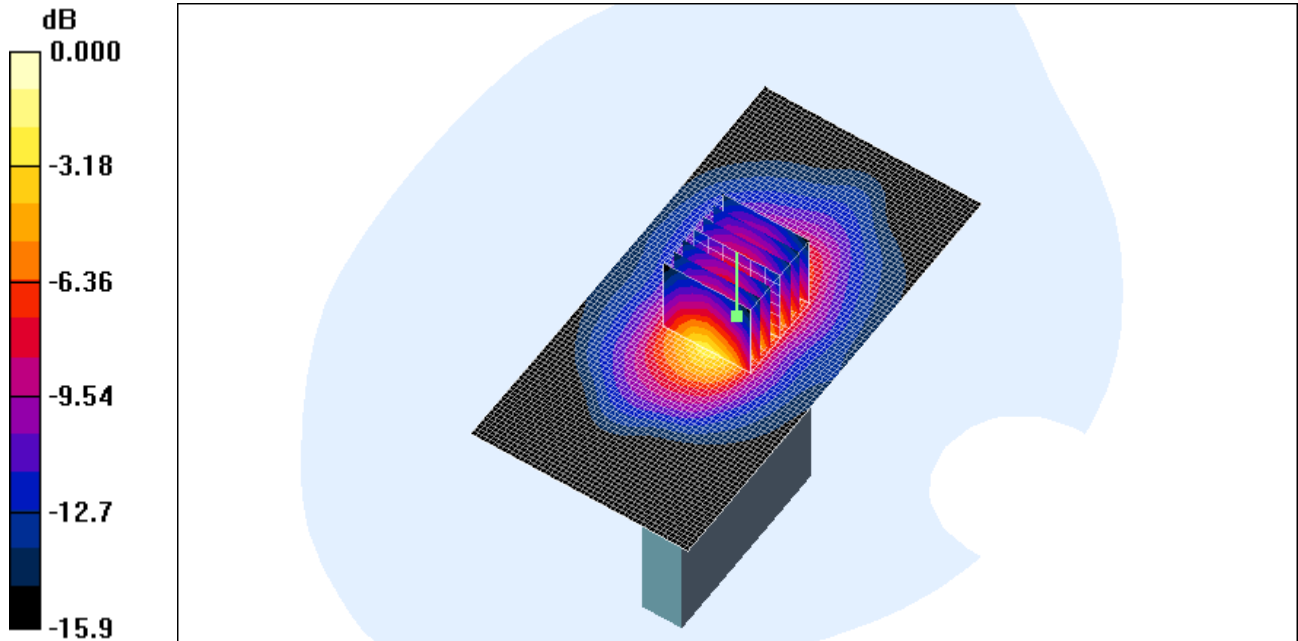
Low/Zoom Scan (7x7x7)/Cube 0: **Measurement grid: dx=5mm, dy=5mm, dz=5mm**

Reference Value = 27.8 V/m; Power Drift = -0.142 dB

Peak SAR (extrapolated) = 1.52 W/kg

SAR(1 g) = 1.01 mW/g; SAR(10 g) = 0.554 mW/g

Maximum value of SAR (measured) = 1.19 mW/g



0 dB = 1.19mW/g

16.5.31 GSM 1900+EGPRS 1TS-Hotspot body-RightSide-High

Date/Time: 2012-8-7 12:03:33

Test Laboratory: SGS-GSM

R208 GSM 1900 +EGPRS 1TS Hotspot body Right High

DUT: R208; Type: GSM/WCDMA/WIFI; Serial: 866322010006055

Communication System: PCS1900-EGPRS Mode; Frequency: 1909.8 MHz;Duty Cycle: 1:8.3

Medium: HSL1900-Body Medium parameters used (interpolated): $f = 1909.8$ MHz; $\sigma = 1.61$ mho/m; $\epsilon_r = 50$; $\rho = 1000$ kg/m³

Phantom section: Flat Section

DASY4 Configuration:

- Probe: ES3DV3 - SN3088; ConvF(4.8, 4.8, 4.8); Calibrated: 2011-11-23
- Sensor-Surface: 4mm (Mechanical Surface Detection)
- Electronics: DAE3 Sn569; Calibrated: 2011-11-16
- Phantom: SAM 12; Type: SAM V4.0; Serial: TP-1283
- Measurement SW: DASY4, V4.7 Build 80; Postprocessing SW: SEMCAD, V1.8 Build 186

High/Area Scan (51x101x1): **Measurement grid: dx=15mm, dy=15mm**

Maximum value of SAR (interpolated) = 1.21 mW/g

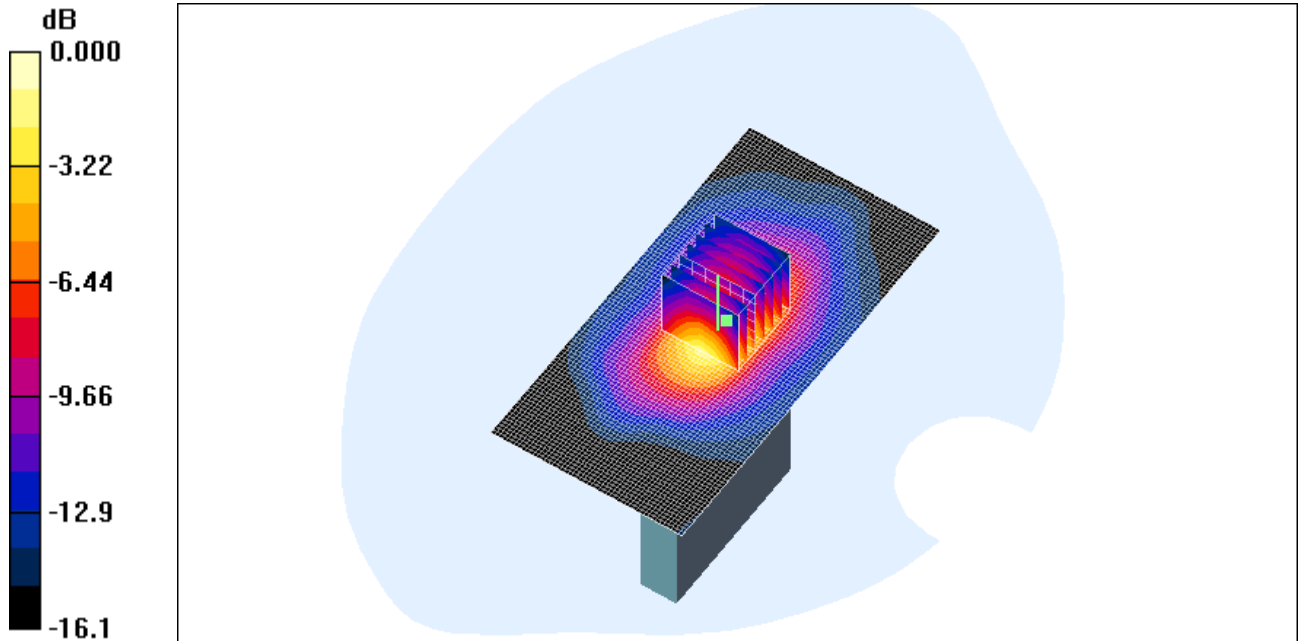
High/Zoom Scan (7x7x7)/Cube 0: **Measurement grid: dx=5mm, dy=5mm, dz=5mm**

Reference Value = 27.6 V/m; Power Drift = -0.177 dB

Peak SAR (extrapolated) = 1.50 W/kg

SAR(1 g) = 1.04 mW/g; SAR(10 g) = 0.570 mW/g

Maximum value of SAR (measured) = 1.16 mW/g



0 dB = 1.16mW/g

16.5.32 GSM 1900+EGPRS 2TS-Hotspot body-RightSide-High

Date/Time: 2012-8-7 11:42:10

Test Laboratory: SGS-GSM

R208 GSM 1900 +EGPRS 2TS Hotspot body Right High

DUT: R208; Type: GSM/WCDMA/WIFI; Serial: 866322010006055

Communication System: PCS1900-EGPRS Mode(2 ts); Frequency: 1909.8 MHz;Duty Cycle: 1:4.15

Medium: HSL1900-Body Medium parameters used (interpolated): $f = 1909.8$ MHz; $\sigma = 1.61$ mho/m; $\epsilon_r = 50$; $\rho = 1000$ kg/m³

Phantom section: Flat Section

DASY4 Configuration:

- Probe: ES3DV3 - SN3088; ConvF(4.8, 4.8, 4.8); Calibrated: 2011-11-23
- Sensor-Surface: 4mm (Mechanical Surface Detection)
- Electronics: DAE3 Sn569; Calibrated: 2011-11-16
- Phantom: SAM 12; Type: SAM V4.0; Serial: TP-1283
- Measurement SW: DASY4, V4.7 Build 80; Postprocessing SW: SEMCAD, V1.8 Build 186

High/Area Scan (51x101x1): **Measurement grid: dx=15mm, dy=15mm**

Maximum value of SAR (interpolated) = 1.21 mW/g

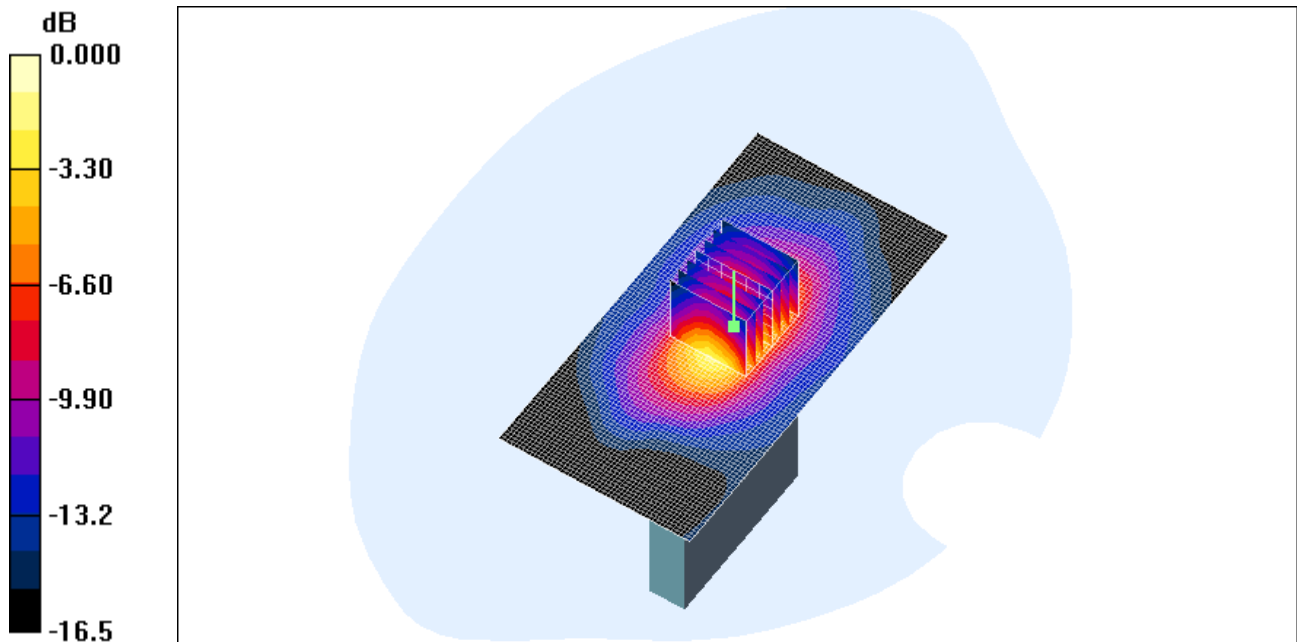
High/Zoom Scan (7x7x7)/Cube 0: **Measurement grid: dx=5mm, dy=5mm, dz=5mm**

Reference Value = 27.5 V/m; Power Drift = -0.120 dB

Peak SAR (extrapolated) = 1.68 W/kg

SAR(1 g) = 1.05 mW/g; SAR(10 g) = 0.568 mW/g

Maximum value of SAR (measured) = 1.22 mW/g



0 dB = 1.22mW/g

16.5.33 GSM 1900+EGPRS 3TS-Hotspot body-RightSide-High

Date/Time: 2012-8-7 11:21:14

Test Laboratory: SGS-GSM

R208 GSM 1900 +EGPRS 3TS Hotspot body Right High

DUT: R208; Type: GSM/WCDMA/WIFI; Serial: 866322010006055

Communication System: PCS1900-EGPRS Mode; Frequency: 1909.8 MHz;Duty Cycle: 1:2.77

Medium: HSL1900-Body Medium parameters used (interpolated): $f = 1909.8$ MHz; $\sigma = 1.61$ mho/m; $\epsilon_r = 50$; $\rho = 1000$ kg/m³

Phantom section: Flat Section

DASY4 Configuration:

- Probe: ES3DV3 - SN3088; ConvF(4.8, 4.8, 4.8); Calibrated: 2011-11-23
- Sensor-Surface: 4mm (Mechanical Surface Detection)
- Electronics: DAE3 Sn569; Calibrated: 2011-11-16
- Phantom: SAM 12; Type: SAM V4.0; Serial: TP-1283
- Measurement SW: DASY4, V4.7 Build 80; Postprocessing SW: SEMCAD, V1.8 Build 186

High/Area Scan (51x101x1): **Measurement grid: dx=15mm, dy=15mm**

Maximum value of SAR (interpolated) = 1.29 mW/g

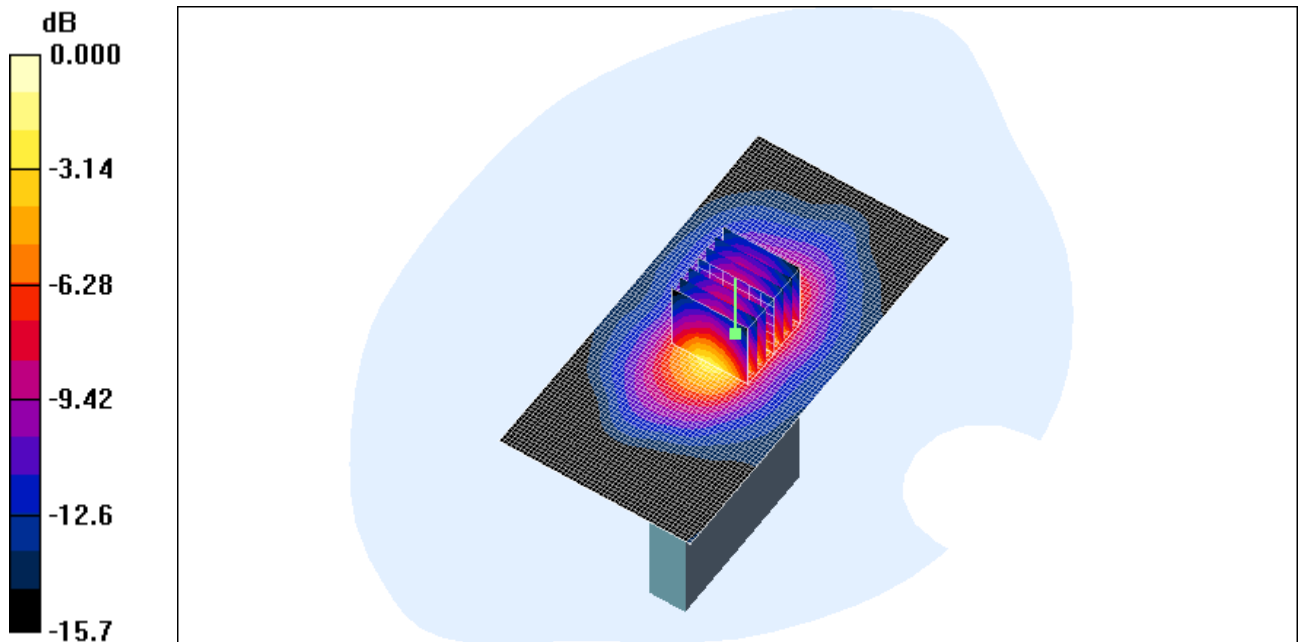
High/Zoom Scan (7x7x7)/Cube 0: **Measurement grid: dx=5mm, dy=5mm, dz=5mm**

Reference Value = 28.4 V/m; Power Drift = -0.145 dB

Peak SAR (extrapolated) = 1.65 W/kg

SAR(1 g) = 1.1 mW/g; SAR(10 g) = 0.604 mW/g

Maximum value of SAR (measured) = 1.30 mW/g



0 dB = 1.30mW/g

16.5.34 GSM 1900+EGPRS 4TS-Hotspot body-RightSide-High

Date/Time: 2012-8-7 10:54:22

Test Laboratory: SGS-GSM

R208 GSM 1900 +EGPRS 4TS Hotspot body Right High

DUT: R208; Type: GSM/WCDMA/WIFI; Serial: 866322010006055

Communication System: PCS1900-EGPRS Mode(4 ts); Frequency: 1909.8 MHz;Duty Cycle: 1:2.075

Medium: HSL1900-Body Medium parameters used (interpolated): $f = 1909.8$ MHz; $\sigma = 1.61$ mho/m; $\epsilon_r = 50$; $\rho = 1000$ kg/m³

Phantom section: Flat Section

DASY4 Configuration:

- Probe: ES3DV3 - SN3088; ConvF(4.8, 4.8, 4.8); Calibrated: 2011-11-23
- Sensor-Surface: 4mm (Mechanical Surface Detection)
- Electronics: DAE3 Sn569; Calibrated: 2011-11-16
- Phantom: SAM 12; Type: SAM V4.0; Serial: TP-1283
- Measurement SW: DASY4, V4.7 Build 80; Postprocessing SW: SEMCAD, V1.8 Build 186

High 2 2/Area Scan (51x101x1): **Measurement grid: dx=15mm, dy=15mm**

Maximum value of SAR (interpolated) = 1.33 mW/g

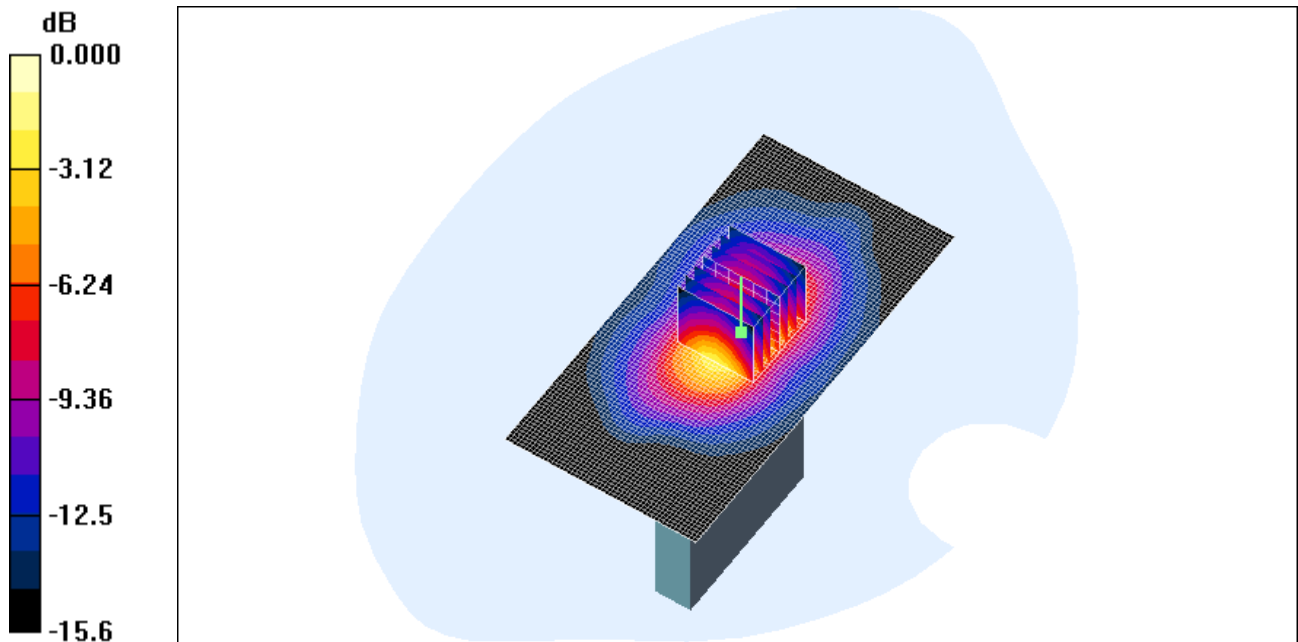
High 2 2/Zoom Scan (7x7x7)/Cube 0: **Measurement grid: dx=5mm, dy=5mm, dz=5mm**

Reference Value = 29.0 V/m; Power Drift = -0.118 dB

Peak SAR (extrapolated) = 1.79 W/kg

SAR(1 g) = 1.16 mW/g; SAR(10 g) = 0.628 mW/g

Maximum value of SAR (measured) = 1.28 mW/g



0 dB = 1.28mW/g

16.5.35 WCDMA Band V-Hotspot body-FrontSide-Middle

Date/Time: 2012-8-7 23:11:20

Test Laboratory: SGS-GSM

R208 WCDMA Band V Hotspot body Front Middle

DUT: R208; Type: GSM/WCDMA/WIFI; Serial: 866322010006055

Communication System: WCDMA Band V ; Frequency: 836.4 MHz;Duty Cycle: 1:1

Medium: HSL835_Body Medium parameters used: f = 836.4 MHz; $\sigma = 0.989$ mho/m; $\epsilon_r = 56.5$; $\rho = 1000$ kg/m³

Phantom section: Flat Section

DASY4 Configuration:

- Probe: ES3DV3 - SN3088; ConvF(6.13, 6.13, 6.13); Calibrated: 2011-11-23
- Sensor-Surface: 4mm (Mechanical Surface Detection)
- Electronics: DAE3 Sn569; Calibrated: 2011-11-16
- Phantom: SAM 12; Type: SAM V4.0; Serial: TP-1283
- Measurement SW: DASY4, V4.7 Build 80; Postprocessing SW: SEMCAD, V1.8 Build 186

Middle/Area Scan (51x101x1): **Measurement grid: dx=15mm, dy=15mm**

Maximum value of SAR (interpolated) = 1.01 mW/g

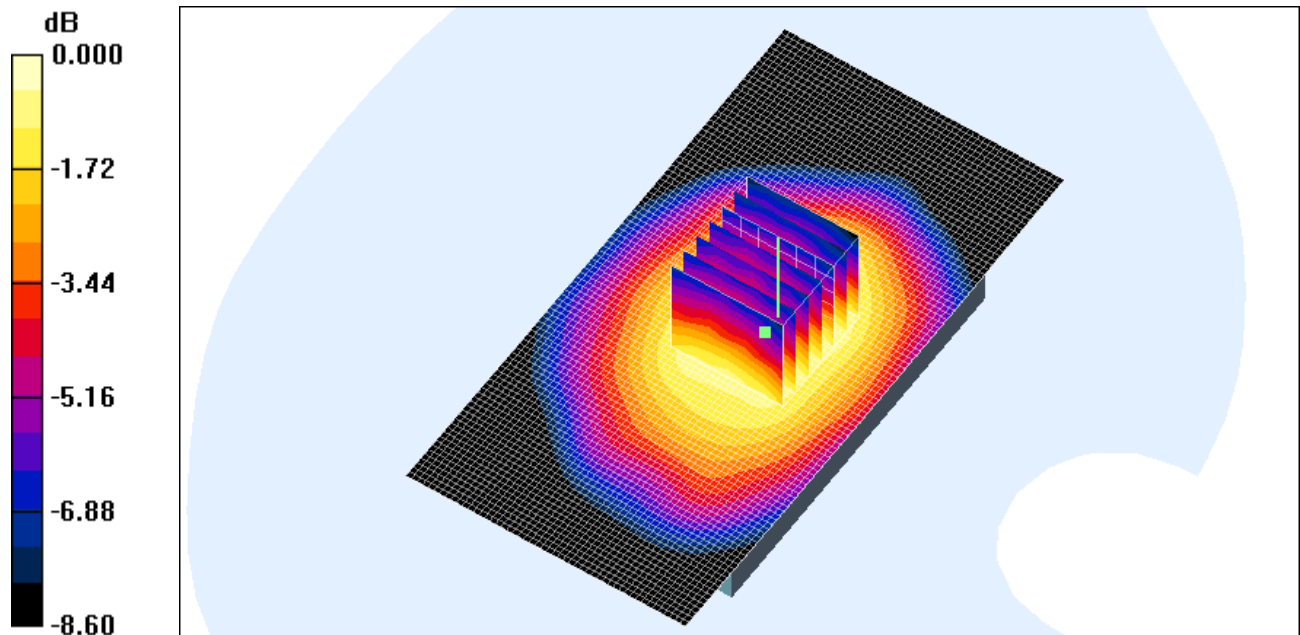
Middle/Zoom Scan (7x7x7)/Cube 0: **Measurement grid: dx=5mm, dy=5mm, dz=5mm**

Reference Value = 30.5 V/m; Power Drift = -0.186 dB

Peak SAR (extrapolated) = 1.08 W/kg

SAR(1 g) = 0.912 mW/g; SAR(10 g) = 0.698 mW/g

Maximum value of SAR (measured) = 0.996 mW/g



0 dB = 0.996mW/g

16.5.36 WCDMA Band V-Hotspot body-FrontSide-High

Date/Time: 2012-8-7 23:39:18

Test Laboratory: SGS-GSM

R208 WCDMA Band V Hotspot body Front High

DUT: R208; Type: GSM/WCDMA/WIFI; Serial: 866322010006055

Communication System: WCDMA Band V ; Frequency: 846.6 MHz;Duty Cycle: 1:1

Medium: HSL835_Body Medium parameters used: f = 846.6 MHz; $\sigma = 0.999$ mho/m; $\epsilon_r = 56.4$; $\rho = 1000$ kg/m³

Phantom section: Flat Section

DASY4 Configuration:

- Probe: ES3DV3 - SN3088; ConvF(6.13, 6.13, 6.13); Calibrated: 2011-11-23
- Sensor-Surface: 4mm (Mechanical Surface Detection)
- Electronics: DAE3 Sn569; Calibrated: 2011-11-16
- Phantom: SAM 12; Type: SAM V4.0; Serial: TP-1283
- Measurement SW: DASY4, V4.7 Build 80; Postprocessing SW: SEMCAD, V1.8 Build 186

High/Area Scan (51x101x1): **Measurement grid: dx=15mm, dy=15mm**

Maximum value of SAR (interpolated) = 0.955 mW/g

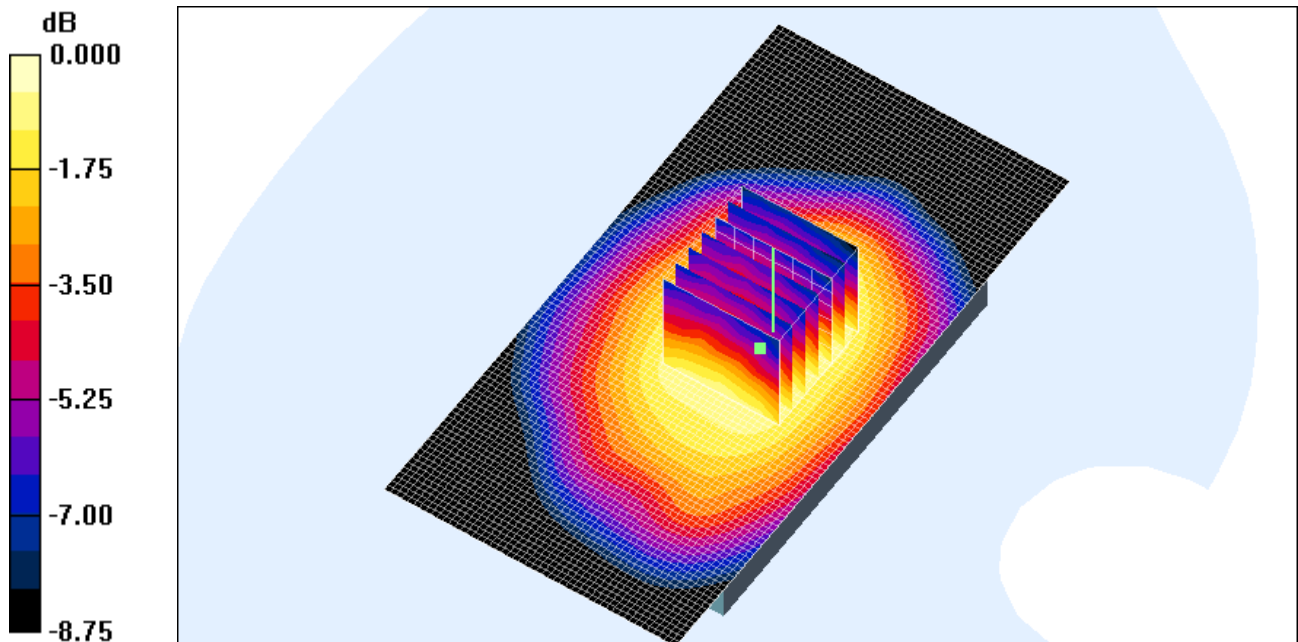
High/Zoom Scan (7x7x7)/Cube 0: **Measurement grid: dx=5mm, dy=5mm, dz=5mm**

Reference Value = 29.9 V/m; Power Drift = -0.0504 dB

Peak SAR (extrapolated) = 1.03 W/kg

SAR(1 g) = 0.870 mW/g; SAR(10 g) = 0.666 mW/g

Maximum value of SAR (measured) = 0.938 mW/g



0 dB = 0.938mW/g

16.5.37 WCDMA Band V-Hotspot body-FrontSide-Low

Date/Time: 2012-8-8 8:12:39

Test Laboratory: SGS-GSM

R208 WCDMA Band V Hotspot body Front Low

DUT: R208; Type: GSM/WCDMA/WIFI; Serial: 866322010006055

Communication System: WCDMA Band V ; Frequency: 826.4 MHz;Duty Cycle: 1:1

Medium: HSL835_Body Medium parameters used: f = 826.4 MHz; $\sigma = 0.98$ mho/m; $\epsilon_r = 56.6$; $\rho = 1000$ kg/m³

Phantom section: Flat Section

DASY4 Configuration:

- Probe: ES3DV3 - SN3088; ConvF(6.13, 6.13, 6.13); Calibrated: 2011-11-23
- Sensor-Surface: 4mm (Mechanical Surface Detection)
- Electronics: DAE3 Sn569; Calibrated: 2011-11-16
- Phantom: SAM 12; Type: SAM V4.0; Serial: TP-1283
- Measurement SW: DASY4, V4.7 Build 80; Postprocessing SW: SEMCAD, V1.8 Build 186

Low/Area Scan (51x101x1): **Measurement grid: dx=15mm, dy=15mm**

Maximum value of SAR (interpolated) = 1.01 mW/g

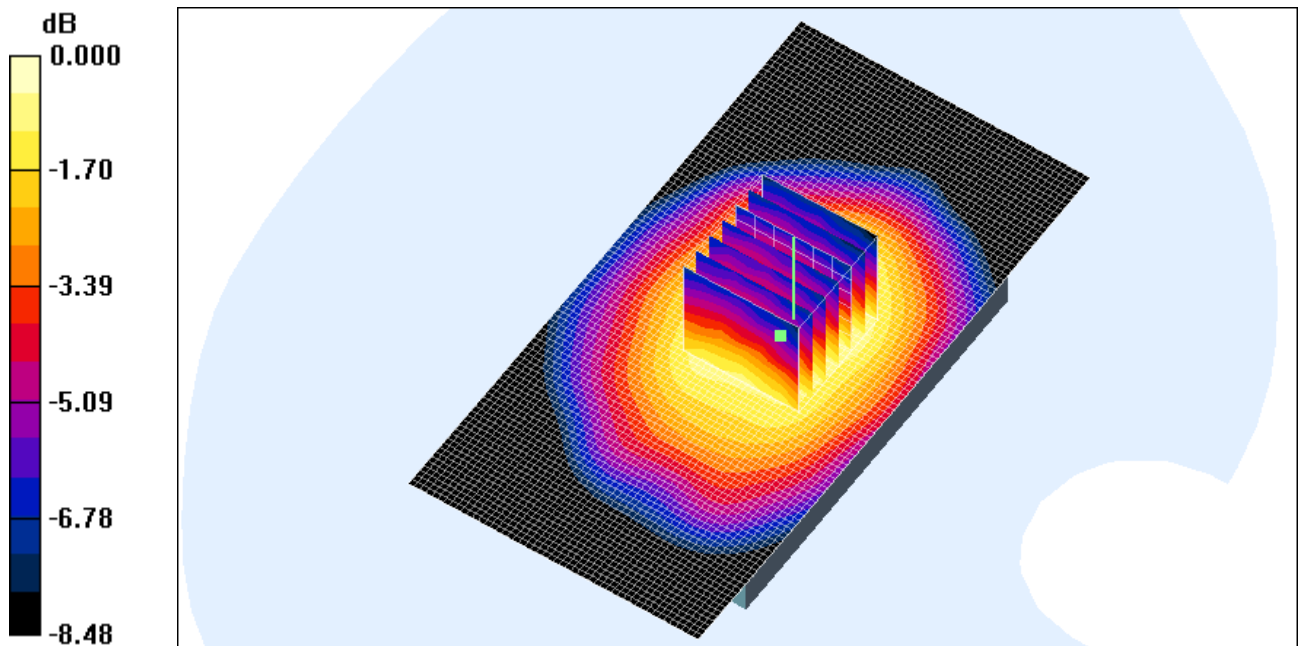
Low/Zoom Scan (7x7x7)/Cube 0: **Measurement grid: dx=5mm, dy=5mm, dz=5mm**

Reference Value = 31.2 V/m; Power Drift = -0.0481 dB

Peak SAR (extrapolated) = 1.07 W/kg

SAR(1 g) = 0.927 mW/g; SAR(10 g) = 0.711 mW/g

Maximum value of SAR (measured) = 1.00 mW/g



0 dB = 1.00mW/g

16.5.38 WCDMA Band V-Hotspot body-BackSide-Middle

Date/Time: 2012-8-8 8:36:48

Test Laboratory: SGS-GSM

R208 WCDMA Band V Hotspot body Back Middle

DUT: R208; Type: GSM/WCDMA/WIFI; Serial: 866322010006055

Communication System: WCDMA Band V ; Frequency: 836.4 MHz;Duty Cycle: 1:1

Medium: HSL835_Body Medium parameters used: f = 836.4 MHz; $\sigma = 0.989$ mho/m; $\epsilon_r = 56.5$; $\rho = 1000$ kg/m³

Phantom section: Flat Section

DASY4 Configuration:

- Probe: ES3DV3 - SN3088; ConvF(6.13, 6.13, 6.13); Calibrated: 2011-11-23
- Sensor-Surface: 4mm (Mechanical Surface Detection)
- Electronics: DAE3 Sn569; Calibrated: 2011-11-16
- Phantom: SAM 12; Type: SAM V4.0; Serial: TP-1283
- Measurement SW: DASY4, V4.7 Build 80; Postprocessing SW: SEMCAD, V1.8 Build 186

Middle/Area Scan (51x101x1): **Measurement grid: dx=15mm, dy=15mm**

Maximum value of SAR (interpolated) = 0.935 mW/g

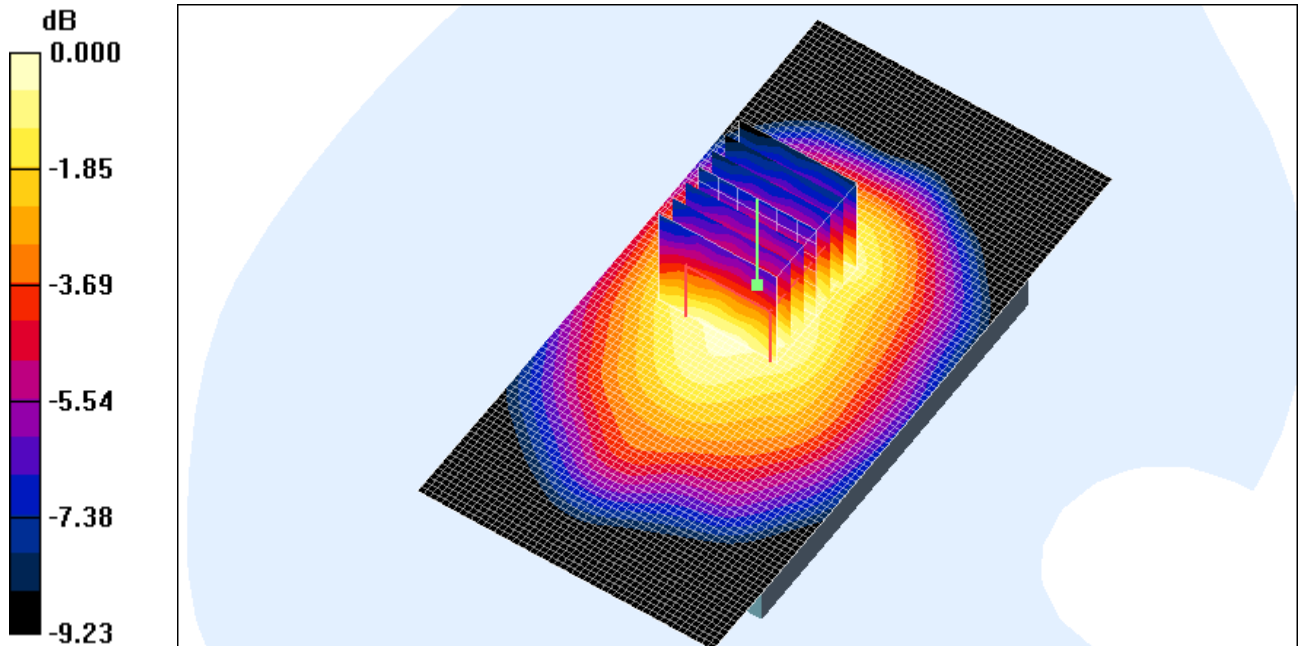
Middle/Zoom Scan (7x7x7)/Cube 0: **Measurement grid: dx=5mm, dy=5mm, dz=5mm**

Reference Value = 29.9 V/m; Power Drift = -0.129 dB

Peak SAR (extrapolated) = 1.09 W/kg

SAR(1 g) = 0.911 mW/g; SAR(10 g) = 0.684 mW/g

Maximum value of SAR (measured) = 0.984 mW/g



0 dB = 0.984mW/g

16.5.39 WCDMA Band V-Hotspot body-BackSide-High

Date/Time: 2012-8-8 9:03:48

Test Laboratory: SGS-GSM

R208 WCDMA Band V Hotspot body Back High

DUT: R208; Type: GSM/WCDMA/WIFI; Serial: 866322010006055

Communication System: WCDMA Band V ; Frequency: 846.6 MHz;Duty Cycle: 1:1

Medium: HSL835_Body Medium parameters used: f = 846.6 MHz; $\sigma = 0.999$ mho/m; $\epsilon_r = 56.4$; $\rho = 1000$ kg/m³

Phantom section: Flat Section

DASY4 Configuration:

- Probe: ES3DV3 - SN3088; ConvF(6.13, 6.13, 6.13); Calibrated: 2011-11-23
- Sensor-Surface: 4mm (Mechanical Surface Detection)
- Electronics: DAE3 Sn569; Calibrated: 2011-11-16
- Phantom: SAM 12; Type: SAM V4.0; Serial: TP-1283
- Measurement SW: DASY4, V4.7 Build 80; Postprocessing SW: SEMCAD, V1.8 Build 186

High/Area Scan (51x101x1): **Measurement grid: dx=15mm, dy=15mm**

Maximum value of SAR (interpolated) = 0.943 mW/g

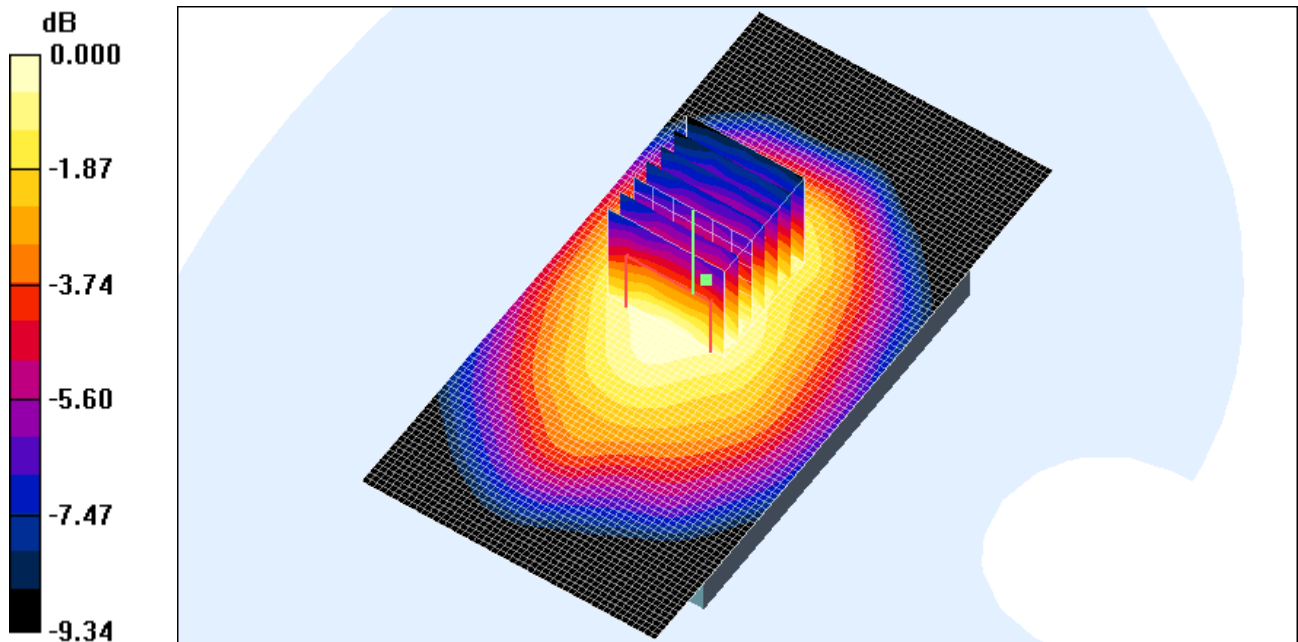
High/Zoom Scan (7x7x7)/Cube 0: **Measurement grid: dx=5mm, dy=5mm, dz=5mm**

Reference Value = 30.1 V/m; Power Drift = -0.0416 dB

Peak SAR (extrapolated) = 1.02 W/kg

SAR(1 g) = 0.885 mW/g; SAR(10 g) = 0.664 mW/g

Maximum value of SAR (measured) = 0.966 mW/g



0 dB = 0.966mW/g

16.5.40 WCDMA Band V-Hotspot body-BackSide-Low

Date/Time: 2012-8-8 9:27:55

Test Laboratory: SGS-GSM

R208 WCDMA Band V Hotspot body Back Low

DUT: R208; Type: GSM/WCDMA/WIFI; Serial: 866322010006055

Communication System: WCDMA Band V ; Frequency: 826.4 MHz;Duty Cycle: 1:1

Medium: HSL835_Body Medium parameters used: f = 826.4 MHz; $\sigma = 0.98$ mho/m; $\epsilon_r = 56.6$; $\rho = 1000$ kg/m³

Phantom section: Flat Section

DASY4 Configuration:

- Probe: ES3DV3 - SN3088; ConvF(6.13, 6.13, 6.13); Calibrated: 2011-11-23
- Sensor-Surface: 4mm (Mechanical Surface Detection)
- Electronics: DAE3 Sn569; Calibrated: 2011-11-16
- Phantom: SAM 12; Type: SAM V4.0; Serial: TP-1283
- Measurement SW: DASY4, V4.7 Build 80; Postprocessing SW: SEMCAD, V1.8 Build 186

Low/Area Scan (51x101x1): **Measurement grid: dx=15mm, dy=15mm**

Maximum value of SAR (interpolated) = 0.927 mW/g

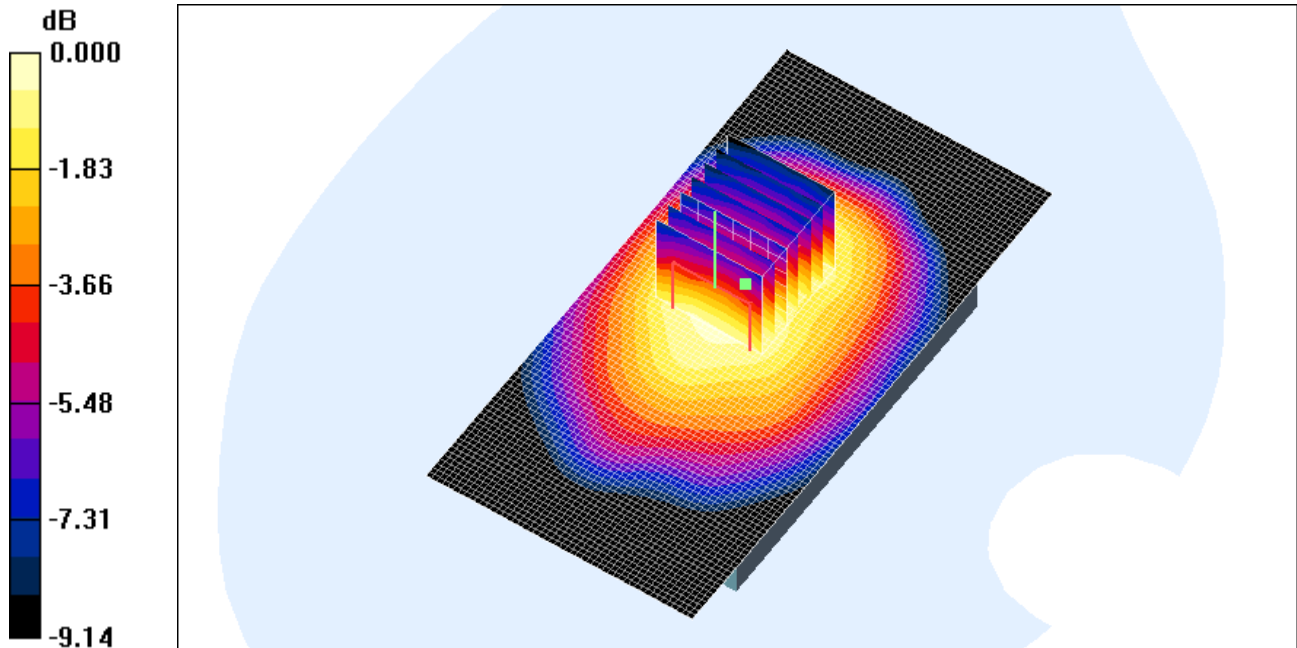
Low/Zoom Scan (7x7x7)/Cube 0: **Measurement grid: dx=5mm, dy=5mm, dz=5mm**

Reference Value = 28.7 V/m; Power Drift = -0.121 dB

Peak SAR (extrapolated) = 1.17 W/kg

SAR(1 g) = 0.871 mW/g; SAR(10 g) = 0.654 mW/g

Maximum value of SAR (measured) = 0.937 mW/g



0 dB = 0.937mW/g

16.5.41 WCDMA Band V-Hotspot body-TopSide-Middle

Date/Time: 2012-8-8 9:51:03

Test Laboratory: SGS-GSM

R208 WCDMA Band V Hotspot body Top Middle

DUT: R208; Type: GSM/WCDMA/WIFI; Serial: 866322010006055

Communication System: WCDMA Band V ; Frequency: 836.4 MHz;Duty Cycle: 1:1

Medium: HSL835_Body Medium parameters used: f = 836.4 MHz; $\sigma = 0.989$ mho/m; $\epsilon_r = 56.5$; $\rho = 1000$ kg/m³

Phantom section: Flat Section

DASY4 Configuration:

- Probe: ES3DV3 - SN3088; ConvF(6.13, 6.13, 6.13); Calibrated: 2011-11-23
- Sensor-Surface: 4mm (Mechanical Surface Detection)
- Electronics: DAE3 Sn569; Calibrated: 2011-11-16
- Phantom: SAM 12; Type: SAM V4.0; Serial: TP-1283
- Measurement SW: DASY4, V4.7 Build 80; Postprocessing SW: SEMCAD, V1.8 Build 186

Middle/Area Scan (51x101x1): **Measurement grid: dx=15mm, dy=15mm**

Maximum value of SAR (interpolated) = 0.456 mW/g

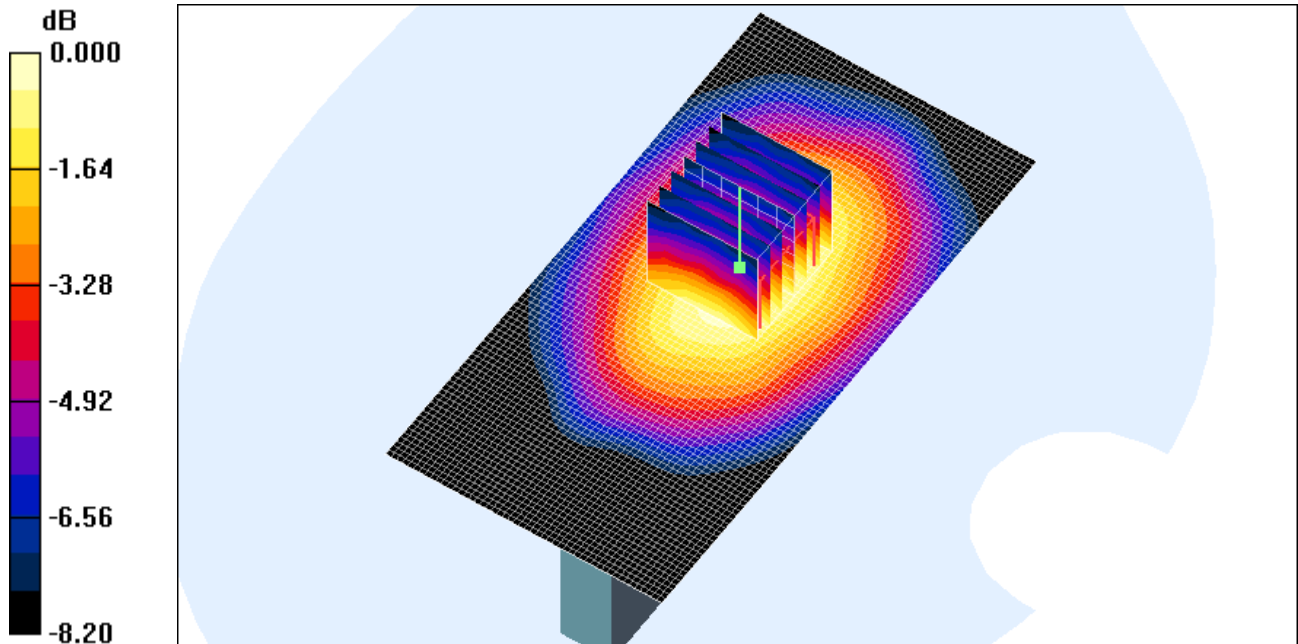
Middle/Zoom Scan (7x7x7)/Cube 0: **Measurement grid: dx=5mm, dy=5mm, dz=5mm**

Reference Value = 20.6 V/m; Power Drift = -0.0485 dB

Peak SAR (extrapolated) = 0.524 W/kg

SAR(1 g) = 0.417 mW/g; SAR(10 g) = 0.308 mW/g

Maximum value of SAR (measured) = 0.451 mW/g



0 dB = 0.451mW/g

16.5.42 WCDMA Band V-Hotspot body-BottomSide-Middle

Date/Time: 2012-8-8 10:15:23

Test Laboratory: SGS-GSM

R208 WCDMA Band V Hotspot body Bottom Middle

DUT: R208; Type: GSM/WCDMA/WIFI; Serial: 866322010006055

Communication System: WCDMA Band V ; Frequency: 836.4 MHz;Duty Cycle: 1:1

Medium: HSL835_Body Medium parameters used: f = 836.4 MHz; $\sigma = 0.989$ mho/m; $\epsilon_r = 56.5$; $\rho = 1000$ kg/m³

Phantom section: Flat Section

DASY4 Configuration:

- Probe: ES3DV3 - SN3088; ConvF(6.13, 6.13, 6.13); Calibrated: 2011-11-23
- Sensor-Surface: 4mm (Mechanical Surface Detection)
- Electronics: DAE3 Sn569; Calibrated: 2011-11-16
- Phantom: SAM 12; Type: SAM V4.0; Serial: TP-1283
- Measurement SW: DASY4, V4.7 Build 80; Postprocessing SW: SEMCAD, V1.8 Build 186

Middle/Area Scan (51x101x1): **Measurement grid: dx=15mm, dy=15mm**

Maximum value of SAR (interpolated) = 0.580 mW/g

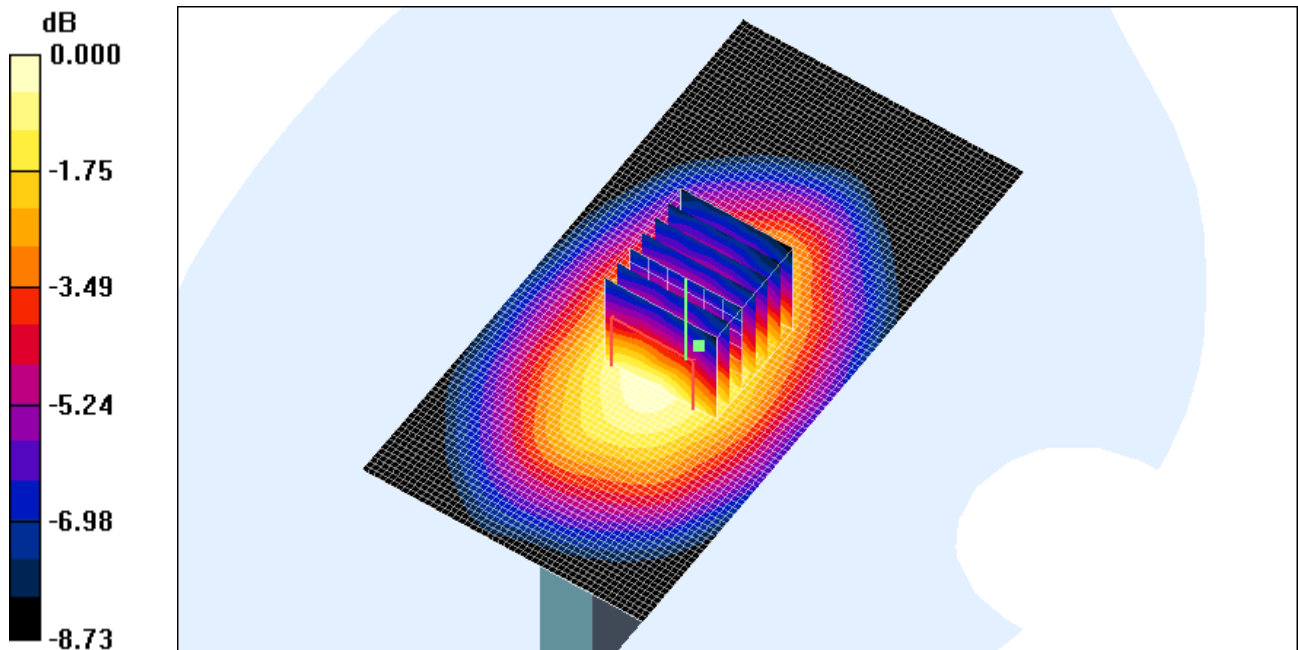
Middle/Zoom Scan (7x7x7)/Cube 0: **Measurement grid: dx=5mm, dy=5mm, dz=5mm**

Reference Value = 23.4 V/m; Power Drift = -0.0415 dB

Peak SAR (extrapolated) = 0.668 W/kg

SAR(1 g) = 0.535 mW/g; SAR(10 g) = 0.390 mW/g

Maximum value of SAR (measured) = 0.577 mW/g



0 dB = 0.577mW/g

16.5.43 WCDMA Band V-Hotspot body-RightSide-Middle

Date/Time: 2012-8-8 10:39:52

Test Laboratory: SGS-GSM

R208 WCDMA Band V Hotspot body Right Middle

DUT: R208; Type: GSM/WCDMA/WIFI; Serial: 866322010006055

Communication System: WCDMA Band V ; Frequency: 836.4 MHz;Duty Cycle: 1:1

Medium: HSL835_Body Medium parameters used: f = 836.4 MHz; $\sigma = 0.989$ mho/m; $\epsilon_r = 56.5$; $\rho = 1000$ kg/m³

Phantom section: Flat Section

DASY4 Configuration:

- Probe: ES3DV3 - SN3088; ConvF(6.13, 6.13, 6.13); Calibrated: 2011-11-23
- Sensor-Surface: 4mm (Mechanical Surface Detection)
- Electronics: DAE3 Sn569; Calibrated: 2011-11-16
- Phantom: SAM 12; Type: SAM V4.0; Serial: TP-1283
- Measurement SW: DASY4, V4.7 Build 80; Postprocessing SW: SEMCAD, V1.8 Build 186

Middle/Area Scan (51x101x1): **Measurement grid: dx=15mm, dy=15mm**

Maximum value of SAR (interpolated) = 0.158 mW/g

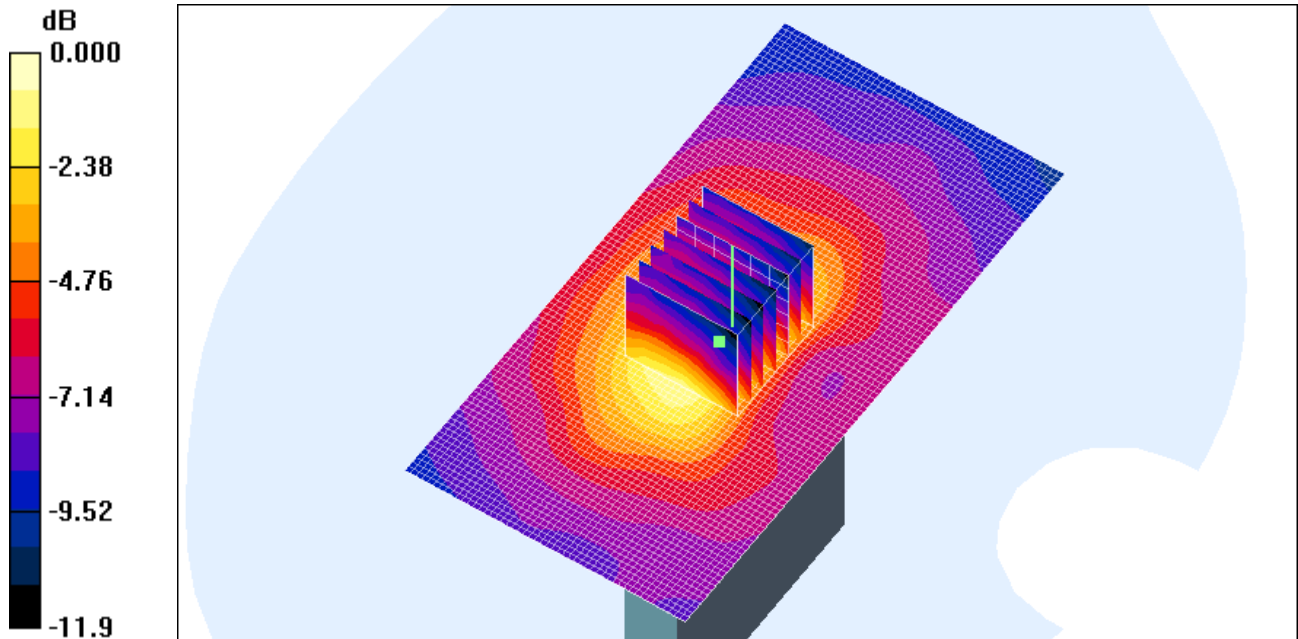
Middle/Zoom Scan (7x7x7)/Cube 0: **Measurement grid: dx=5mm, dy=5mm, dz=5mm**

Reference Value = 12.4 V/m; Power Drift = -0.0501 dB

Peak SAR (extrapolated) = 0.194 W/kg

SAR(1 g) = 0.137 mW/g; SAR(10 g) = 0.090 mW/g

Maximum value of SAR (measured) = 0.152 mW/g



0 dB = 0.152mW/g

16.5.44 HSDPA Band V-Hotspot body-FrontSide-Low

Date/Time: 2012-8-8 11:03:38

Test Laboratory: SGS-GSM

R208 WCDMA Band V+HSDPA Hotspot body Front Low

DUT: R208; Type: GSM/WCDMA/WIFI; Serial: 866322010006055

Communication System: WCDMA Band V +HSDPA; Frequency: 826.4 MHz;Duty Cycle: 1:1

Medium: HSL835_Body Medium parameters used: f = 826.4 MHz; $\sigma = 0.98$ mho/m; $\epsilon_r = 56.6$; $\rho = 1000$ kg/m³

Phantom section: Flat Section

DASY4 Configuration:

- Probe: ES3DV3 - SN3088; ConvF(6.13, 6.13, 6.13); Calibrated: 2011-11-23
- Sensor-Surface: 4mm (Mechanical Surface Detection)
- Electronics: DAE3 Sn569; Calibrated: 2011-11-16
- Phantom: SAM 12; Type: SAM V4.0; Serial: TP-1283
- Measurement SW: DASY4, V4.7 Build 80; Postprocessing SW: SEMCAD, V1.8 Build 186

Low/Area Scan (51x101x1): **Measurement grid: dx=15mm, dy=15mm**

Maximum value of SAR (interpolated) = 1.00 mW/g

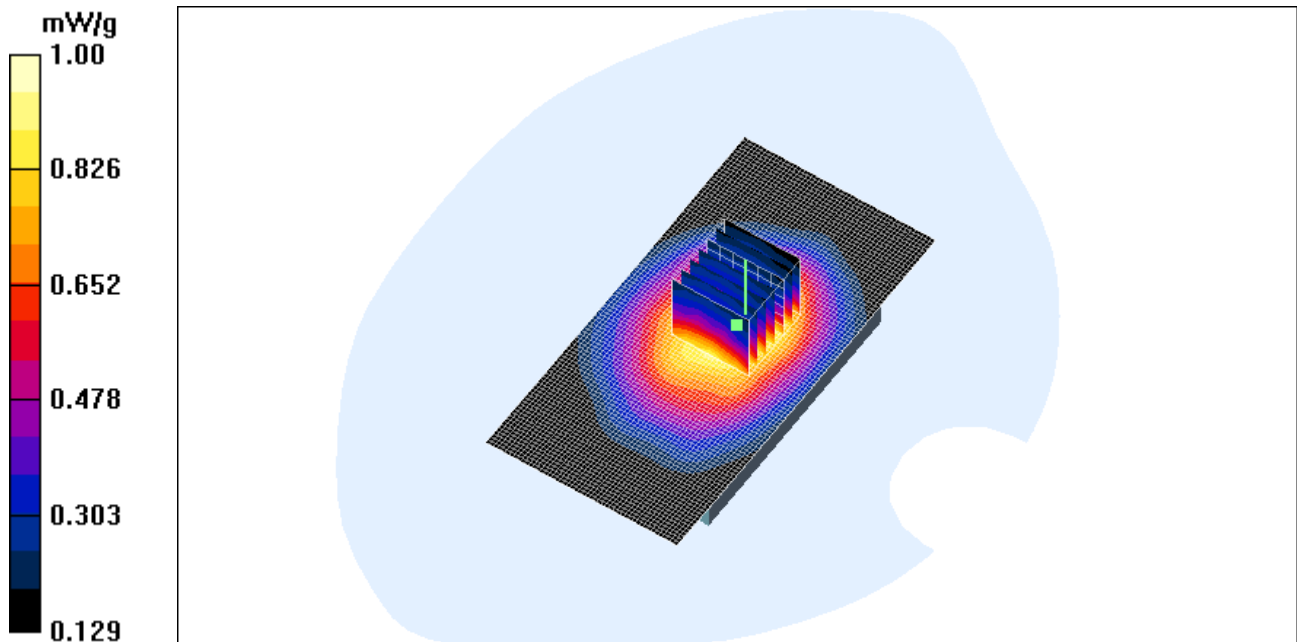
Low/Zoom Scan (7x7x7)/Cube 0: **Measurement grid: dx=5mm, dy=5mm, dz=5mm**

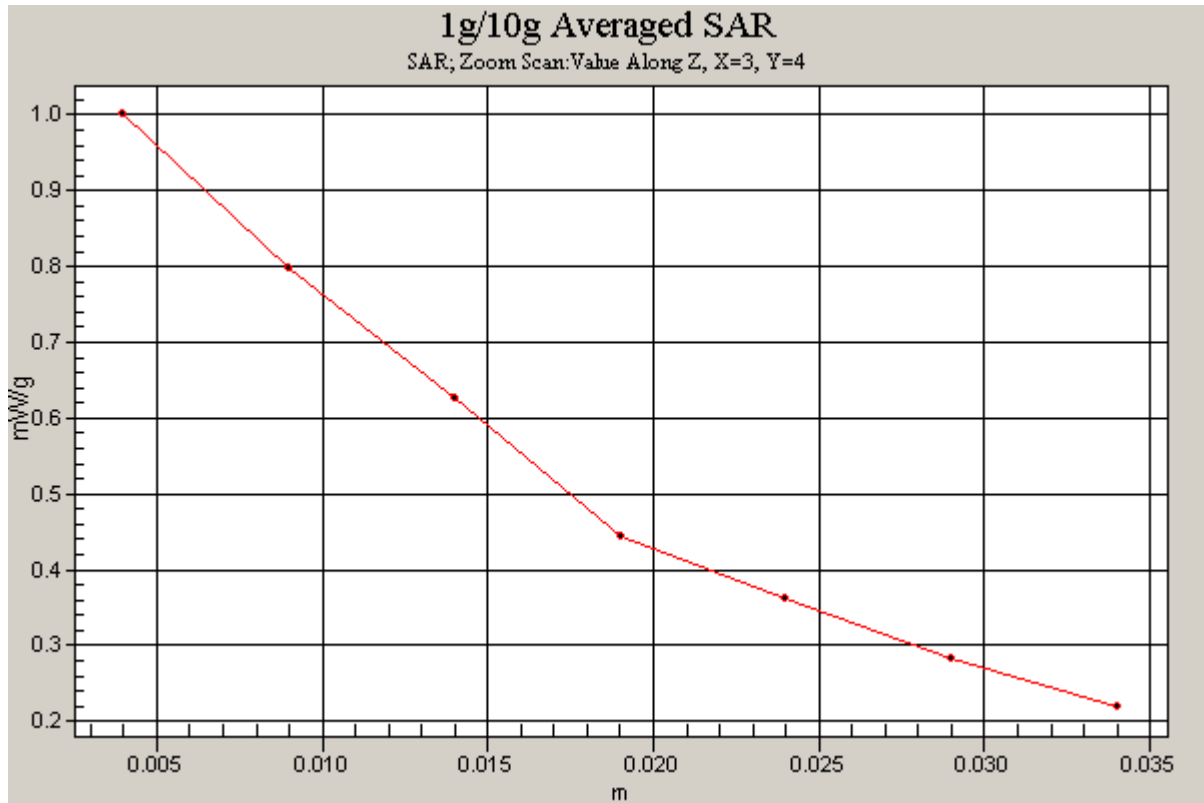
Reference Value = 30.7 V/m; Power Drift = -0.173 dB

Peak SAR (extrapolated) = 1.11 W/kg

SAR(1 g) = 0.936 mW/g; SAR(10 g) = 0.716 mW/g

Maximum value of SAR (measured) = 1.00 mW/g





16.5.45 HSUPA Band V-Hotspot body-FrontSide-Low

Date/Time: 2012-8-8 11:28:40

Test Laboratory: SGS-GSM

R208 WCDMA Band V+HSUPA Hotspot body Front Low

DUT: R208; Type: GSM/WCDMA/WIFI; Serial: 866322010006055

Communication System: WCDMA Band V +HSUPA; Frequency: 826.4 MHz; Duty Cycle: 1:1

Medium: HSL835_Body Medium parameters used: f = 826.4 MHz; $\sigma = 0.98$ mho/m; $\epsilon_r = 56.6$; $\rho = 1000$ kg/m³

Phantom section: Flat Section

DASY4 Configuration:

- Probe: ES3DV3 - SN3088; ConvF(6.13, 6.13, 6.13); Calibrated: 2011-11-23
- Sensor-Surface: 4mm (Mechanical Surface Detection)
- Electronics: DAE3 Sn569; Calibrated: 2011-11-16
- Phantom: SAM 12; Type: SAM V4.0; Serial: TP-1283
- Measurement SW: DASY4, V4.7 Build 80; Postprocessing SW: SEMCAD, V1.8 Build 186

Low/Area Scan (51x101x1): **Measurement grid: dx=15mm, dy=15mm**

Maximum value of SAR (interpolated) = 0.790 mW/g

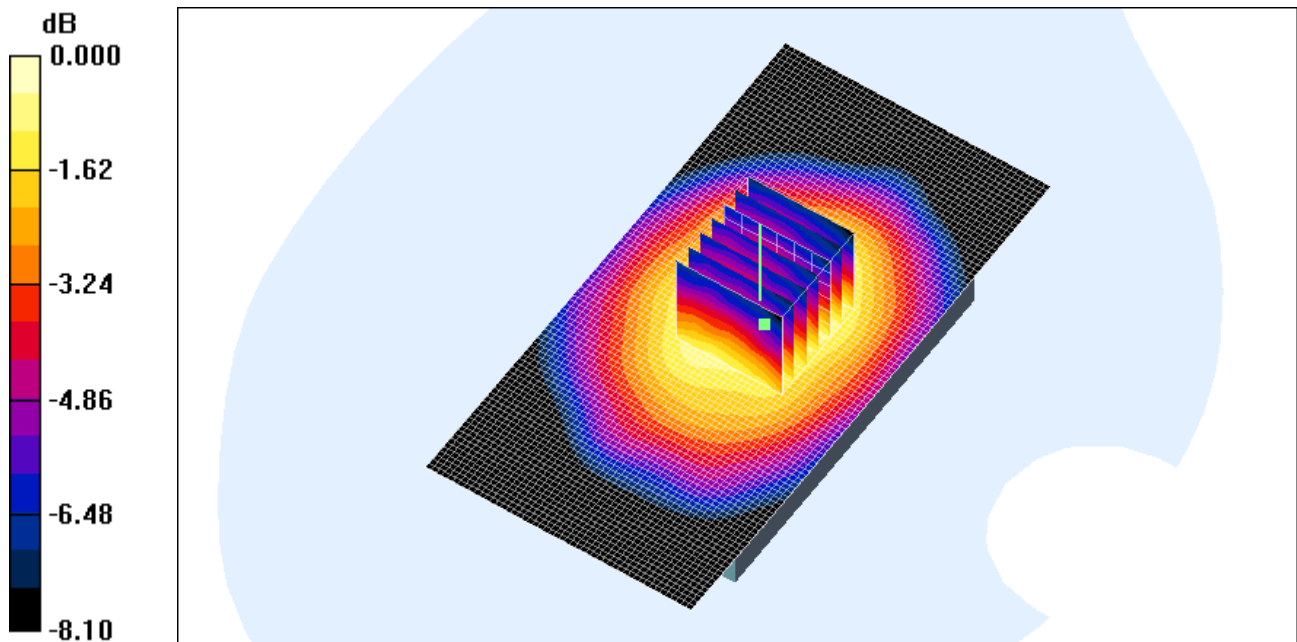
Low/Zoom Scan (7x7x7)/Cube 0: **Measurement grid: dx=5mm, dy=5mm, dz=5mm**

Reference Value = 27.6 V/m; Power Drift = -0.0420 dB

Peak SAR (extrapolated) = 0.916 W/kg

SAR(1 g) = 0.741 mW/g; SAR(10 g) = 0.565 mW/g

Maximum value of SAR (measured) = 0.798 mW/g



0 dB = 0.798mW/g

16.5.46 802.11b-Hotspot body-FrontSide-Middle

Date/Time: 2012-8-14 8:57:27

Test Laboratory: SGS-GSM

R208 802.11b Hotspot body Front Middle

DUT: R208; Type: GSM/WCDMA/WIFI; Serial: 866322010006055

Communication System: 802.11b; Frequency: 2437 MHz; Duty Cycle: 1:1

Medium: HSL2450-Body Medium parameters used: $f = 2437$ MHz; $\sigma = 1.99$ mho/m; $\epsilon_r = 51.4$; $\rho = 1000$ kg/m³

Phantom section: Flat Section

DASY4 Configuration:

- Probe: ES3DV3 - SN3088; ConvF(4.35, 4.35, 4.35); Calibrated: 2011-11-23
- Sensor-Surface: 4mm (Mechanical Surface Detection)
- Electronics: DAE3 Sn569; Calibrated: 2011-11-16
- Phantom: SAM 12; Type: SAM V4.0; Serial: TP-1283
- Measurement SW: DASY4, V4.7 Build 80; Postprocessing SW: SEMCAD, V1.8 Build 186

Middle/Area Scan (61x81x1): **Measurement grid: dx=15mm, dy=15mm**

Maximum value of SAR (interpolated) = 0.163 mW/g

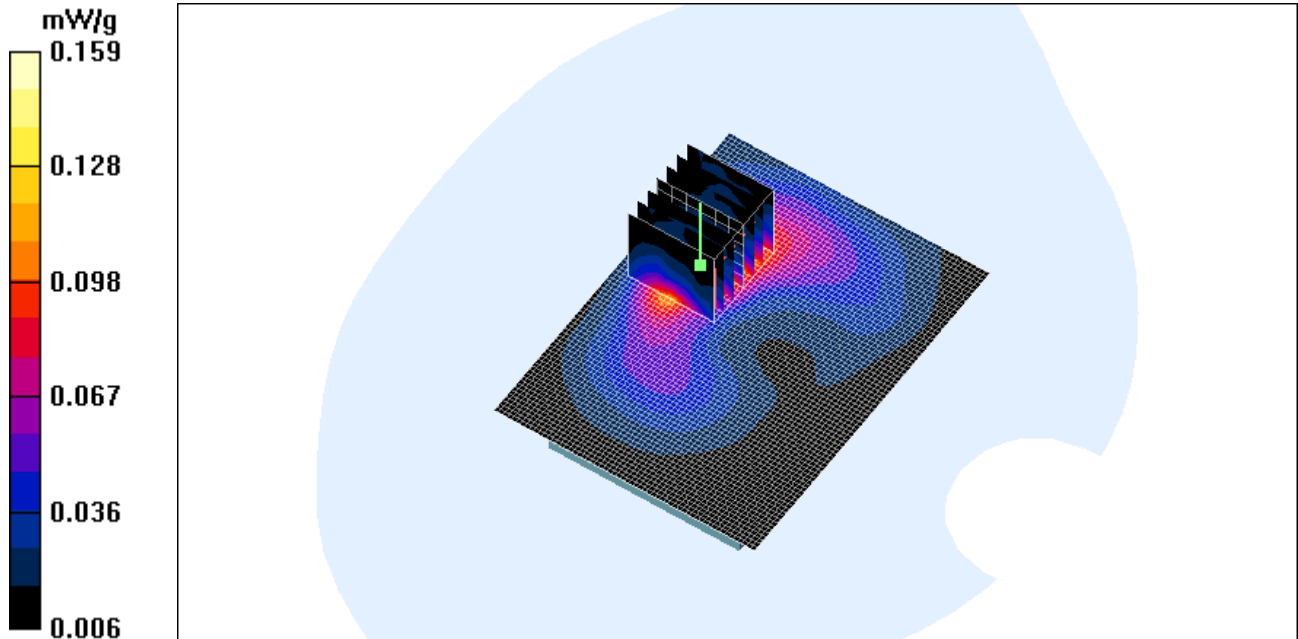
Middle/Zoom Scan (7x7x7)/Cube 0: **Measurement grid: dx=5mm, dy=5mm, dz=5mm**

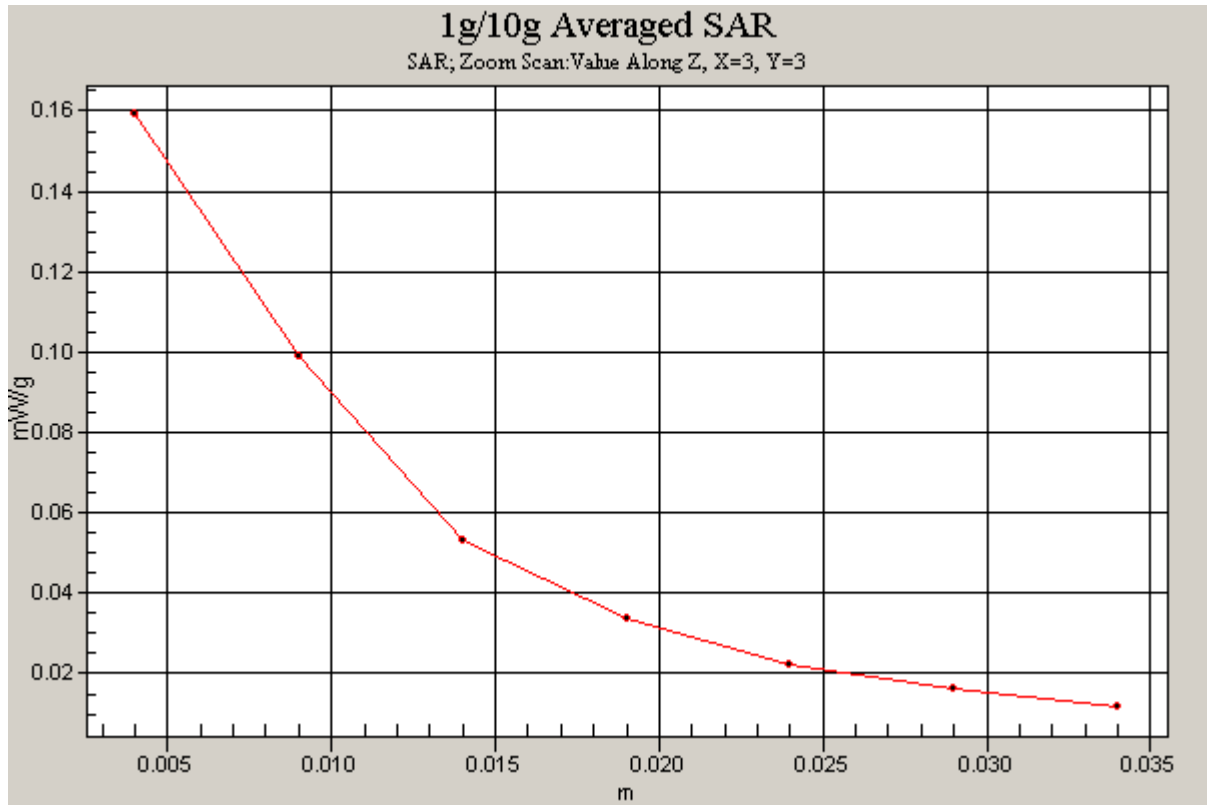
Reference Value = 3.17 V/m; Power Drift = -0.200 dB

Peak SAR (extrapolated) = 0.230 W/kg

SAR(1 g) = 0.139 mW/g; SAR(10 g) = 0.078 mW/g

Maximum value of SAR (measured) = 0.159 mW/g





16.5.47 802.11b-Hotspot body-BackSide-Middle

Date/Time: 2012-8-14 9:40:12

Test Laboratory: SGS-GSM

R208 802.11b Hotspot body Back Middle

DUT: R208; Type: GSM/WCDMA/WIFI; Serial: 866322010006055

Communication System: 802.11b; Frequency: 2437 MHz; Duty Cycle: 1:1

Medium: HSL2450-Body Medium parameters used: $f = 2437$ MHz; $\sigma = 1.99$ mho/m; $\epsilon_r = 51.4$; $\rho = 1000$ kg/m³

Phantom section: Flat Section

DASY4 Configuration:

- Probe: ES3DV3 - SN3088; ConvF(4.35, 4.35, 4.35); Calibrated: 2011-11-23
- Sensor-Surface: 4mm (Mechanical Surface Detection)
- Electronics: DAE3 Sn569; Calibrated: 2011-11-16
- Phantom: SAM 12; Type: SAM V4.0; Serial: TP-1283
- Measurement SW: DASY4, V4.7 Build 80; Postprocessing SW: SEMCAD, V1.8 Build 186

Middle/Area Scan (61x81x1): **Measurement grid: dx=15mm, dy=15mm**

Maximum value of SAR (interpolated) = 0.029 mW/g

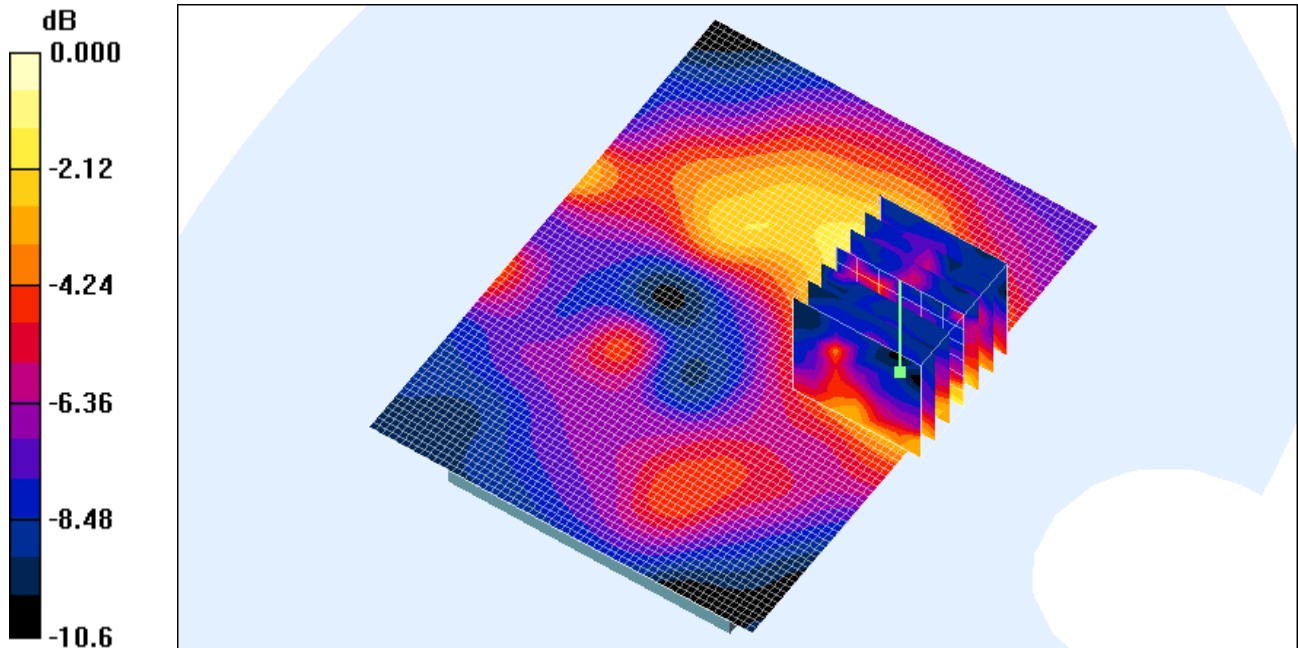
Middle/Zoom Scan (7x7x7)/Cube 0: **Measurement grid: dx=5mm, dy=5mm, dz=5mm**

Reference Value = 2.15 V/m; Power Drift = -0.083 dB

Peak SAR (extrapolated) = 0.062 W/kg

SAR(1 g) = 0.029 mW/g; SAR(10 g) = 0.018 mW/g

Maximum value of SAR (measured) = 0.035 mW/g



0 dB = 0.035mW/g

16.5.48 802.11b-Hotspot body-TopSide-Middle

Date/Time: 2012-8-14 10:05:13

Test Laboratory: SGS-GSM

R208 802.11b Hotspot body Top Middle

DUT: R208; Type: GSM/WCDMA/WIFI; Serial: 866322010006055

Communication System: 802.11b; Frequency: 2437 MHz; Duty Cycle: 1:1

Medium: HSL2450-Body Medium parameters used: $f = 2437$ MHz; $\sigma = 1.99$ mho/m; $\epsilon_r = 51.4$; $\rho = 1000$ kg/m³

Phantom section: Flat Section

DASY4 Configuration:

- Probe: ES3DV3 - SN3088; ConvF(4.35, 4.35, 4.35); Calibrated: 2011-11-23
- Sensor-Surface: 4mm (Mechanical Surface Detection)
- Electronics: DAE3 Sn569; Calibrated: 2011-11-16
- Phantom: SAM 12; Type: SAM V4.0; Serial: TP-1283
- Measurement SW: DASY4, V4.7 Build 80; Postprocessing SW: SEMCAD, V1.8 Build 186

Middle/Area Scan (51x91x1): **Measurement grid: dx=15mm, dy=15mm**

Maximum value of SAR (interpolated) = 0.100 mW/g

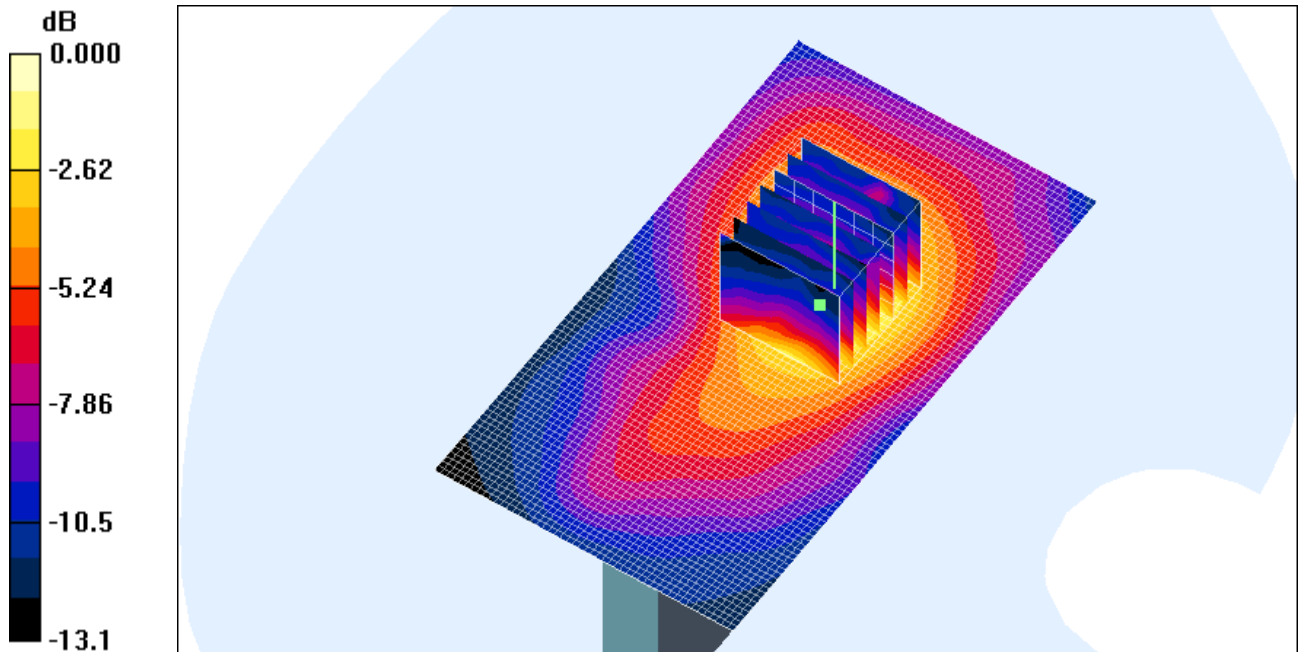
Middle/Zoom Scan (7x7x7)/Cube 0: **Measurement grid: dx=5mm, dy=5mm, dz=5mm**

Reference Value = 5.13 V/m; Power Drift = -0.0420 dB

Peak SAR (extrapolated) = 0.141 W/kg

SAR(1 g) = 0.086 mW/g; SAR(10 g) = 0.051 mW/g

Maximum value of SAR (measured) = 0.098 mW/g



0 dB = 0.098mW/g

16.5.49 802.11b-Hotspot body-FrontSide-High

Date/Time: 2012-8-14 13:20:56

Test Laboratory: SGS-GSM

R208 802.11b Hotspot body Front High

DUT: R208; Type: GSM/WCDMA/WIFI; Serial: 866322010006055

Communication System: 802.11b; Frequency: 2462 MHz; Duty Cycle: 1:1

Medium: HSL2450-Body Medium parameters used: $f = 2462$ MHz; $\sigma = 2.01$ mho/m; $\epsilon_r = 51.1$; $\rho = 1000$ kg/m³

Phantom section: Flat Section

DASY4 Configuration:

- Probe: ES3DV3 - SN3088; ConvF(4.35, 4.35, 4.35); Calibrated: 2011-11-23
- Sensor-Surface: 4mm (Mechanical Surface Detection)
- Electronics: DAE3 Sn569; Calibrated: 2011-11-16
- Phantom: SAM 12; Type: SAM V4.0; Serial: TP-1283
- Measurement SW: DASY4, V4.7 Build 80; Postprocessing SW: SEMCAD, V1.8 Build 186

High/Area Scan (61x81x1): **Measurement grid: dx=15mm, dy=15mm**

Maximum value of SAR (interpolated) = 0.117 mW/g

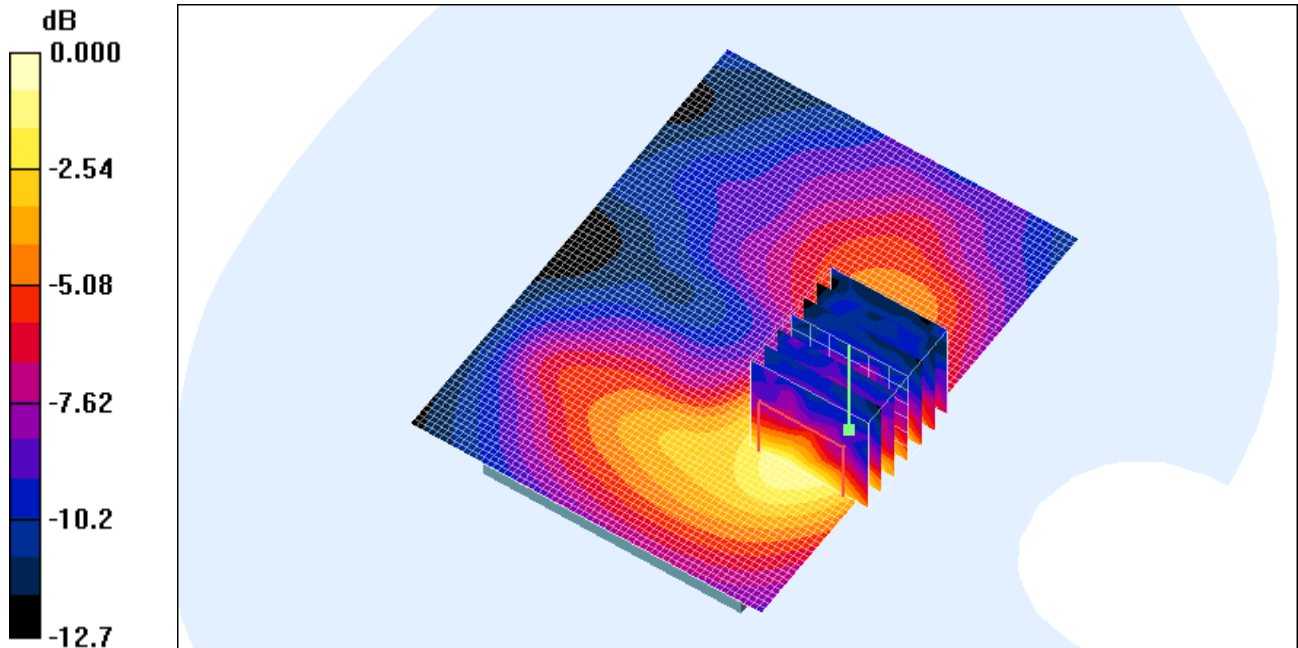
High/Zoom Scan (7x7x7)/Cube 0: **Measurement grid: dx=5mm, dy=5mm, dz=5mm**

Reference Value = 2.56 V/m; Power Drift = 0.0898 dB

Peak SAR (extrapolated) = 0.184 W/kg

SAR(1 g) = 0.111 mW/g; SAR(10 g) = 0.064 mW/g

Maximum value of SAR (measured) = 0.126 mW/g



0 dB = 0.126mW/g

16.5.50 802.11b-Hotspot body-FrontSide-Low

Date/Time: 2012-8-14 13:44:37

Test Laboratory: SGS-GSM

R208 802.11b Hotspot body Front Low

DUT: R208; Type: GSM/WCDMA/WIFI; Serial: 866322010006055

Communication System: 802.11b; Frequency: 2412 MHz; Duty Cycle: 1:1

Medium: HSL2450-Body Medium parameters used: $f = 2412$ MHz; $\sigma = 1.96$ mho/m; $\epsilon_r = 51.6$; $\rho = 1000$ kg/m³

Phantom section: Flat Section

DASY4 Configuration:

- Probe: ES3DV3 - SN3088; ConvF(4.35, 4.35, 4.35); Calibrated: 2011-11-23
- Sensor-Surface: 4mm (Mechanical Surface Detection)
- Electronics: DAE3 Sn569; Calibrated: 2011-11-16
- Phantom: SAM 12; Type: SAM V4.0; Serial: TP-1283
- Measurement SW: DASY4, V4.7 Build 80; Postprocessing SW: SEMCAD, V1.8 Build 186

Low/Area Scan (61x81x1): **Measurement grid: dx=15mm, dy=15mm**

Maximum value of SAR (interpolated) = 0.135 mW/g

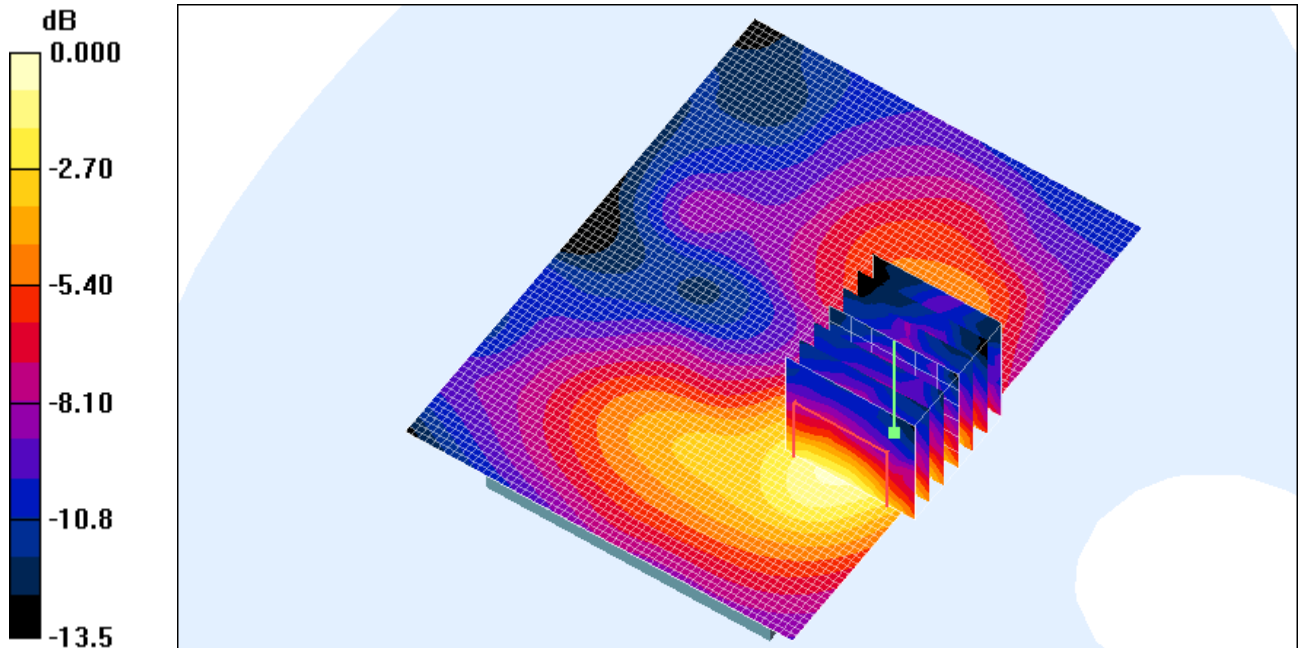
Low/Zoom Scan (7x7x7)/Cube 0: **Measurement grid: dx=5mm, dy=5mm, dz=5mm**

Reference Value = 2.66 V/m; Power Drift = -0.133 dB

Peak SAR (extrapolated) = 0.211 W/kg

SAR(1 g) = 0.123 mW/g; SAR(10 g) = 0.069 mW/g

Maximum value of SAR (measured) = 0.140 mW/g



0 dB = 0.140mW/g

16.5.51 802.11g-Hotspot body-FrontSide-Middle

Date/Time: 2012-8-14 14:10:13

Test Laboratory: SGS-GSM

R208 802.11g Hotspot body Front Middle

DUT: R208; Type: GSM/WCDMA/WIFI; Serial: 866322010006055

Communication System: 802.11g; Frequency: 2437 MHz; Duty Cycle: 1:1

Medium: HSL2450-Body Medium parameters used: $f = 2437$ MHz; $\sigma = 1.99$ mho/m; $\epsilon_r = 51.4$; $\rho = 1000$ kg/m³

Phantom section: Flat Section

DASY4 Configuration:

- Probe: ES3DV3 - SN3088; ConvF(4.35, 4.35, 4.35); Calibrated: 2011-11-23
- Sensor-Surface: 4mm (Mechanical Surface Detection)
- Electronics: DAE3 Sn569; Calibrated: 2011-11-16
- Phantom: SAM 12; Type: SAM V4.0; Serial: TP-1283
- Measurement SW: DASY4, V4.7 Build 80; Postprocessing SW: SEMCAD, V1.8 Build 186

Middle/Area Scan (61x81x1): **Measurement grid: dx=15mm, dy=15mm**

Maximum value of SAR (interpolated) = 0.085 mW/g

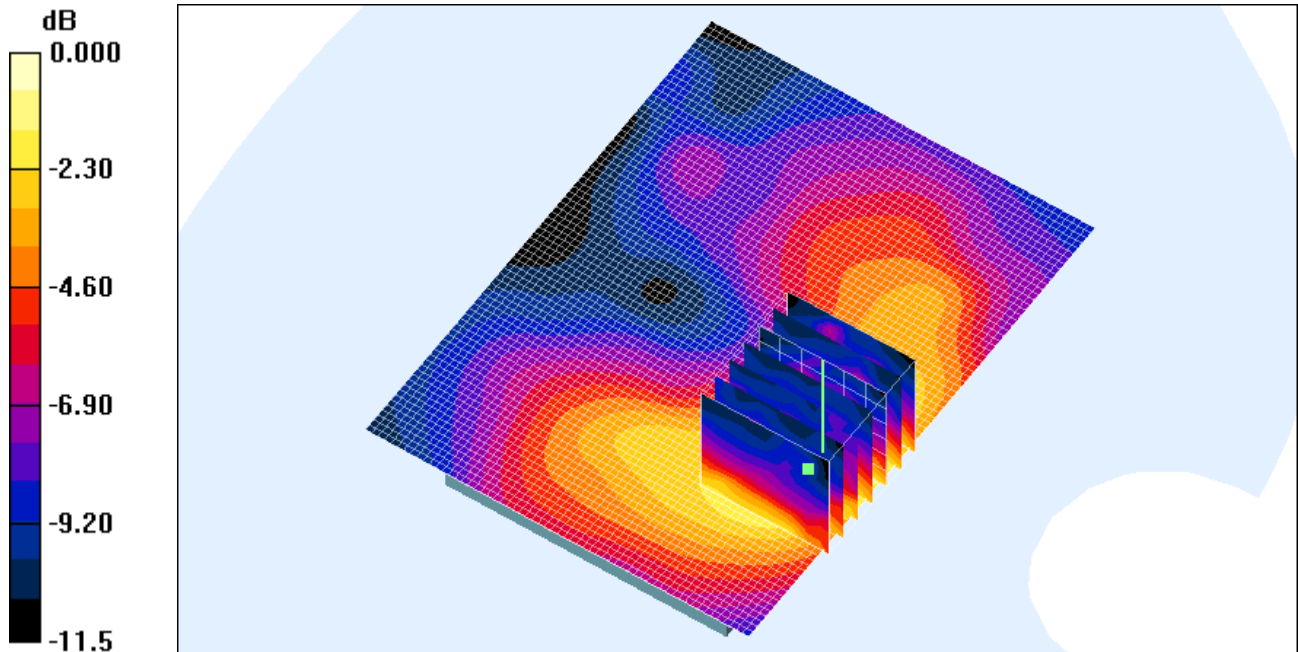
Middle/Zoom Scan (7x7x7)/Cube 0: **Measurement grid: dx=5mm, dy=5mm, dz=5mm**

Reference Value = 2.39 V/m; Power Drift = 0.166 dB

Peak SAR (extrapolated) = 0.124 W/kg

SAR(1 g) = 0.079 mW/g; SAR(10 g) = 0.047 mW/g

Maximum value of SAR (measured) = 0.088 mW/g



0 dB = 0.088mW/g

16.5.52 802.11n-Hotspot body-FrontSide-Middle

Date/Time: 2012-8-14 14:34:06

Test Laboratory: SGS-GSM

R208 802.11n Hotspot body Front Middle

DUT: R208; Type: GSM/WCDMA/WIFI; Serial: 866322010006055

Communication System: 802.11n; Frequency: 2437 MHz; Duty Cycle: 1:1

Medium: HSL2450-Body Medium parameters used: $f = 2437$ MHz; $\sigma = 1.99$ mho/m; $\epsilon_r = 51.4$; $\rho = 1000$ kg/m³

Phantom section: Flat Section

DASY4 Configuration:

- Probe: ES3DV3 - SN3088; ConvF(4.35, 4.35, 4.35); Calibrated: 2011-11-23
- Sensor-Surface: 4mm (Mechanical Surface Detection)
- Electronics: DAE3 Sn569; Calibrated: 2011-11-16
- Phantom: SAM 12; Type: SAM V4.0; Serial: TP-1283
- Measurement SW: DASY4, V4.7 Build 80; Postprocessing SW: SEMCAD, V1.8 Build 186

Middle/Area Scan (61x81x1): **Measurement grid: dx=15mm, dy=15mm**

Maximum value of SAR (interpolated) = 0.067 mW/g

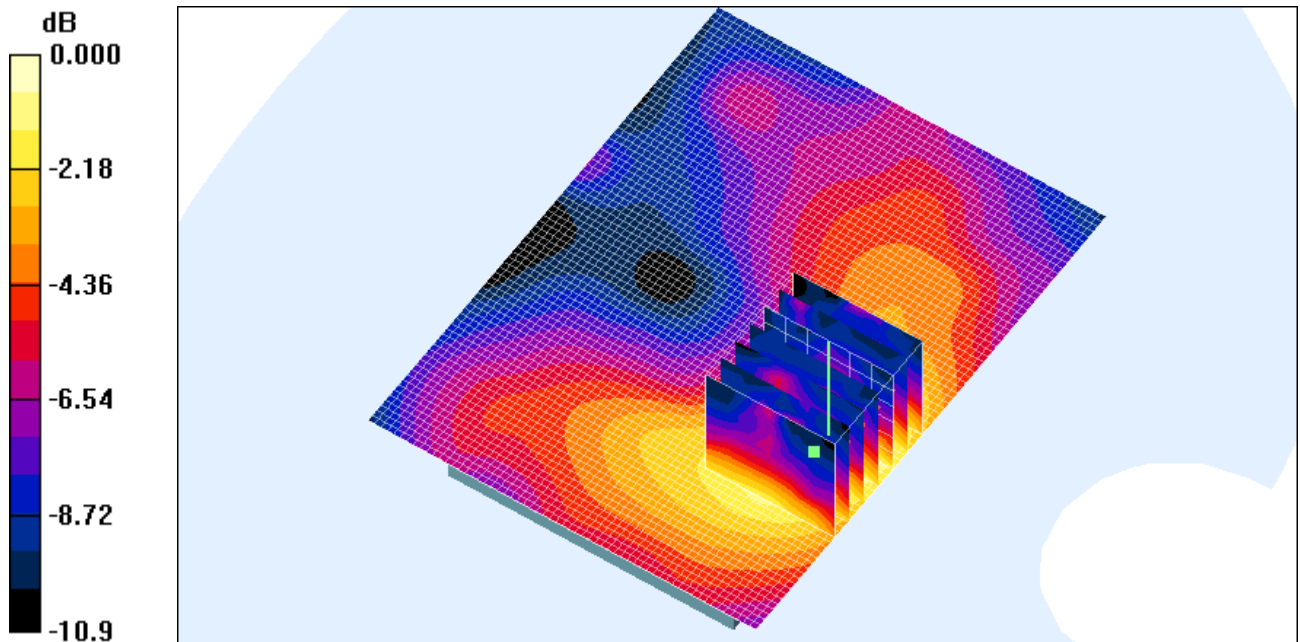
Middle/Zoom Scan (7x7x7)/Cube 0: **Measurement grid: dx=5mm, dy=5mm, dz=5mm**

Reference Value = 2.46 V/m; Power Drift = 0.121 dB

Peak SAR (extrapolated) = 0.095 W/kg

SAR(1 g) = 0.064 mW/g; SAR(10 g) = 0.040 mW/g

Maximum value of SAR (measured) = 0.071 mW/g



0 dB = 0.071mW/g

16. Identification of Samples

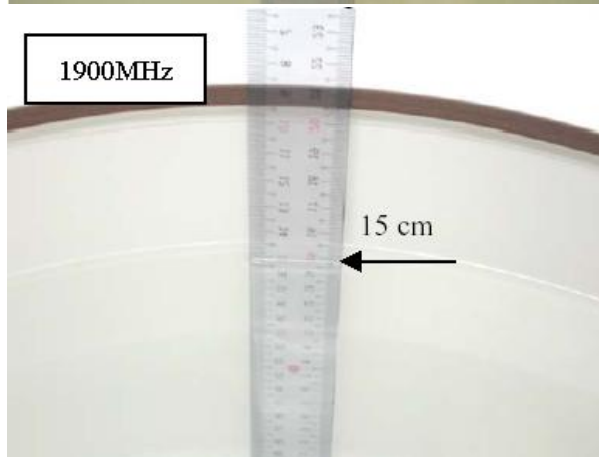
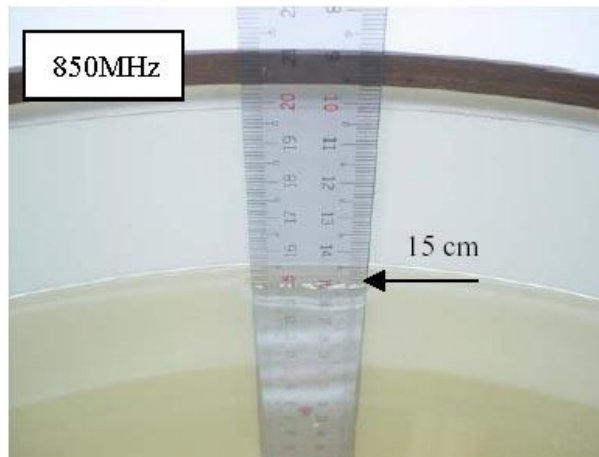
Product Definition	Production Unit	
Device Type	Portable	
Limit Type	General Population/Uncontrolled	
Product Name	Vodafone Mobile Wi-Fi	
Brand Name	Vodafone	
Marketing Name	R208	
Model Name	R208	
Final Software Version Tested	21.136.05.00.11	
Final Hardware Version Tested	CH1E5756SM	
Battery Type	N/A	
	N/A	
Antenna Type	Inner antenna	
WCDMA Frequency Bands	Band V	Tx: 826~847MHz
		Rx: 871~892MHz
GSM Frequency Bands	GSM850	Tx: 824~849MHz
		Rx: 869~894MHz
	PCS1900	Tx:1850~1910MHz
		Rx:1930~1990MHz
WIFI Frequency Bands	802.11b	Tx/Rx: 2.412~2.462GHz
	802.11g	Tx/Rx: 2.412~2.462GHz
	802.11n	Tx/Rx: 2.412~2.462GHz
Modulation Mode	GMSK/QPSK	
Power Class	GSM 850	4
	PCS 1900	1
GPRS Multislot class	12	
EGPRS Multislot class	12	
WCDMA Power Class	3	
HSDPA UE Category	14	
HSUPA UE Category	6	
DC-HSDPA UE Category	24	
IMEI	866322010006055	
Date of receipt	07-30, 2012	
Date of Testing Start	08-06, 2012	

Date of Testing End	08-14, 2012
---------------------	-------------

Annex A Photographs of Test Setup



Fig.A-1 Photograph of the SAR measurement System



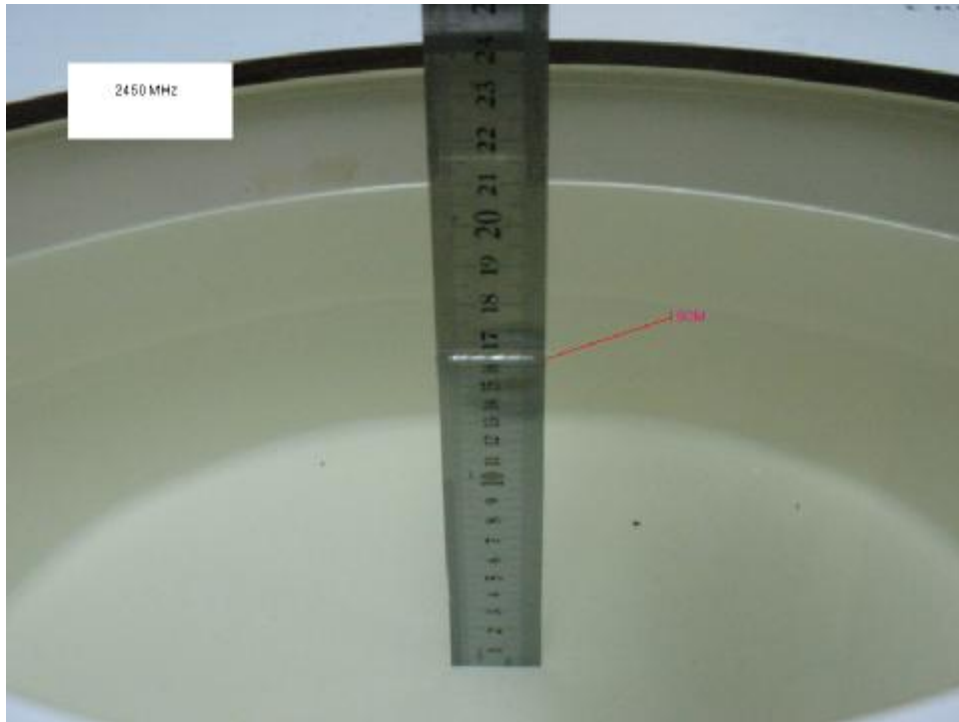


Fig.A-2 Photograph of the Tissue Simulant Liquid depth 15cm for Body Worn

Annex B

Tissue Simulant Liquid

**Annex B.1
Liquid**

Recipes for Tissue Simulant

The following tables give the recipes for tissue simulating liquids to be used in different frequency bands.

Frequency (MHz)	835		900		1800-2000		2450	
Tissue Type	Head	Body	Head	Body	Head	Body	Head	Body
Ingredient (% by weight)								
Water	40.30	50.75	40.30	50.75	55.24	70.17	62.7	73.26
Salt (NaCl)	1.38	0.94	1.38	0.94	0.31	0.39	0.5	0.04
Sucrose	57.90	48.21	57.90	48.21	0	0	0	0
HEC	0.24	0	0.24	0	0	0	0	0
Bactericide	0.18	0.10	0.10	0.10	0	0	0	0
DGBE	0	0	0	0	44.45	29.44	36.8	26.7
Measurement dielectric parameters								
Dielectric Constant	41.9	55.0	41.1	54.5	39.2	53.2	39.8	52.5
Conductivity (S/m)	0.93	0.97	1.04	1.06	1.45	1.59	1.88	1.78
Target values								
Dielectric Constant	41.5	55.2	41.5	55.0	40.0	53.3	39.2	52.7
Conductivity (S/m)	0.90	0.97	0.97	1.05	1.40	1.52	1.80	1.95
Salt: 99+% Pure Sodium Chloride					Sucrose: 98+% Pure Sucrose			
Water: De-ionized, 16 MΩ ⁺ resistivity					HEC: Hydroxyethyl Cellulose			
DGBE: 99+% Di(ethylene glycol) butyl ether, [2-(2-butoxyethoxy)ethanol]								

Table B-1 Recipe of Tissue Simulat Liquid

**Annex B.2
Simulant Liquid**

Measurement for Tissue

The dielectric properties for this Tissue Simulant Liquids were measured by using the Agilent Model 85070D Dielectric Probe (rates frequency band 200 MHz to 20 GHz) in conjunction with Agilent E5071B Network Analyzer (300 KHz-8500 MHz). The Conductivity (σ) and Permittivity (ρ) are listed in Table 1. For the SAR measurement given in this report. The temperature variation of the Tissue Simulant Liquids was $22\pm 2^\circ\text{C}$.

Frequency (MHz)	Tissue Type	Limit/Measured	Permittivity (ρ)	Conductivity (σ)	Temp ($^\circ\text{C}$)
835	Body	Recommended Limit	55.2 \pm 5% (52.44~57.96)	0.97 \pm 5% (0.922~1.02)	22 \pm 2
		Measured, 08-07,2012	56.5	0.988	21.5
1900	Body	Recommended Limit	53.3 \pm 5% (50.64~55.97)	1.52 \pm 5% (1.44~1.60)	22 \pm 2
		Measured, 08-06,2012	53.4	1.52	21.6
2450	Body	Recommended Limit	52.7 \pm 5% (50.07~55.34)	1.95 \pm 5% (1.85~2.05)	22 \pm 2
		Measured, 08-14,2012	51.3	2.01	21.5

Table B-2 Measurement result of Tissue electric parameters

Annex C

SAR System Validation

The microwave circuit arrangement for system verification is sketched in Fig. C-1. The daily system accuracy verification occurs within the flat section of the SAM phantom. A SAR measurement was performed to see if the measured SAR was within +/- 10% from the target SAR values. These tests were done at 835&1900MHz. The tests were conducted on the same days as the measurement of the EUT. The obtained results from the system accuracy verification are displayed in the table C-1 (A power level of 250mw was input to the dipole antenna). During the tests, the ambient temperature of the laboratory was in the range 22°C, the relative humidity was in the range 60% and the liquid depth above the ear reference points was above 15 cm in all the cases. It is seen that the system is operating within its specification, as the results are within acceptable tolerance of the reference values.

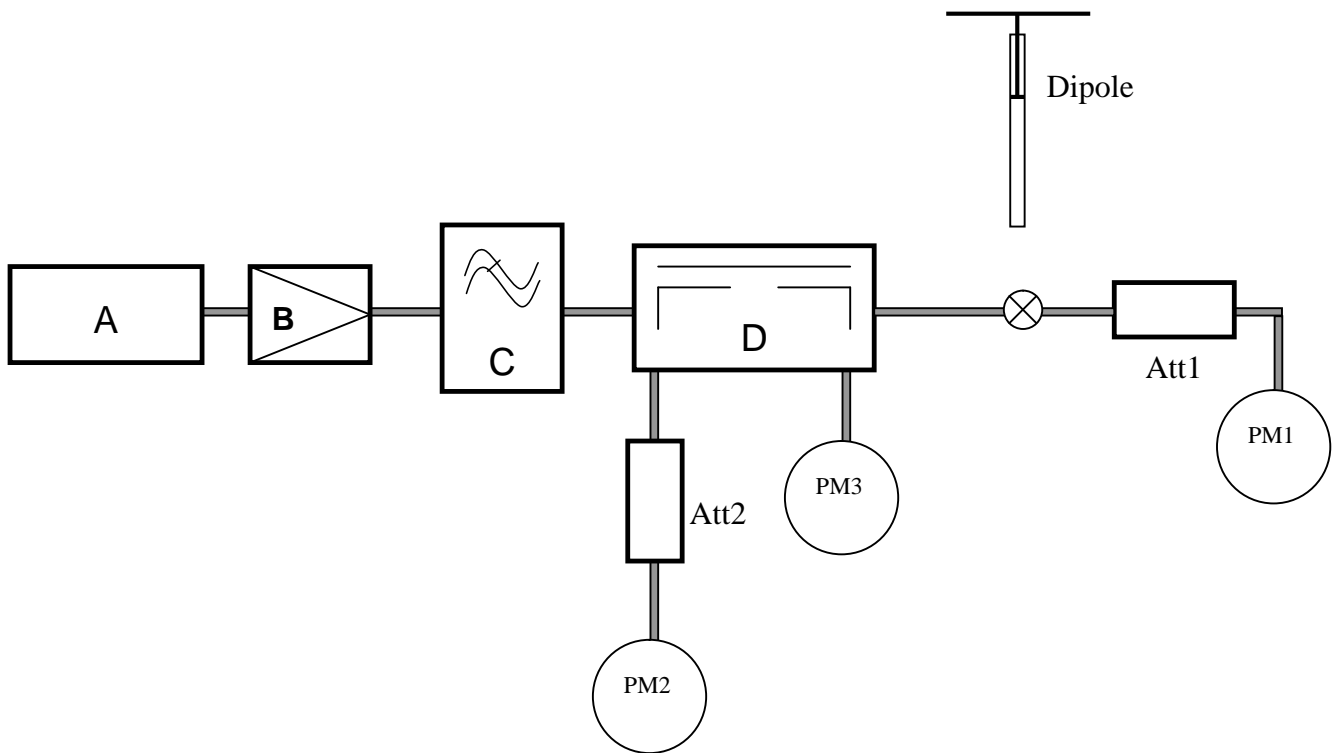


Fig. C-1 the microwave circuit arrangement used for SAR system verification

- A. Agilent E4438C Signal Generator
- B. Mini-Circuit ZHL-42 Preamplifier
- C. Mini-Circuit VLF-2500+ Low Pass Filter
- D. Mini-Circuits ZABDC20-252H-N+ Bi-DIR Coupling
- PM1. Power Sensor NRP-Z92
- PM2. Agilent Model E4416A Power Meter

PM3. Power Sensor NRP-Z92

Validation Kit	Frequency (MHz)	Tissue Type	Limit/Measurement		
			Condition	Recommended/Measured	1g
D835V2	835	Body	Calibration data		2.43
			Nomalized to 1mW(for nominal Head TSL parameters)	Recommended Limit	9.72±10% (8.75~10.69)
			Nomalized to 1W(for nominal Head TSL parameters)	-	9.8
			250mW input power	Measured, 08-07, 2012	2.45
D1900V2	1900	Body	Calibration data		10.6
			Nomalized to 1mW(for nominal Head TSL parameters)	Recommended Limit	42.4±10% (38.16~46.64)
			Nomalized to 1W(for nominal Head TSL parameters)	-	42
			250mW input power	Measured, 08-06, 2012	10.5
D2450V2	2450	Body	Calibration data		13.2
			Nomalized to 1mW(for nominal Head TSL parameters)	Recommended Limit	52.8±10% (47.52~58.08)
			Nomalized to 1W(for nominal Head TSL parameters)	-	49.2
			250mW input power	Measured, 08-14, 2012	12.3

Table C-1 SAR System Validation Result

System Validation for 835MHz-Body

Date/Time: 2012-8-7 13:56:03

Test Laboratory: SGS-GSM

System Performance Check at 835MHz Body

DUT: Dipole 835MHz; Type: D835V2; Serial: D835V2 - SN:4d105

Communication System: CW; Frequency: 835 MHz; Duty Cycle: 1:1

Medium: HSL835_Body Medium parameters used: f = 835 MHz; $\sigma = 0.988$ mho/m; $\epsilon_r = 56.5$; $\rho = 1000$ kg/m³

Phantom section: Flat Section

DASY4 Configuration:

- Probe: ES3DV3 - SN3088; ConvF(6.13, 6.13, 6.13); Calibrated: 2011-11-23
- Sensor-Surface: 4mm (Mechanical Surface Detection)
- Electronics: DAE3 Sn569; Calibrated: 2011-11-16
- Phantom: SAM 12; Type: SAM V4.0; Serial: TP-1283
- Measurement SW: DASY4, V4.7 Build 80; Postprocessing SW: SEMCAD, V1.8 Build 186

d=15mm, Pin=250mW 2/Area Scan (61x121x1): **Measurement grid: dx=15mm, dy=15mm**

Maximum value of SAR (interpolated) = 2.68 mW/g

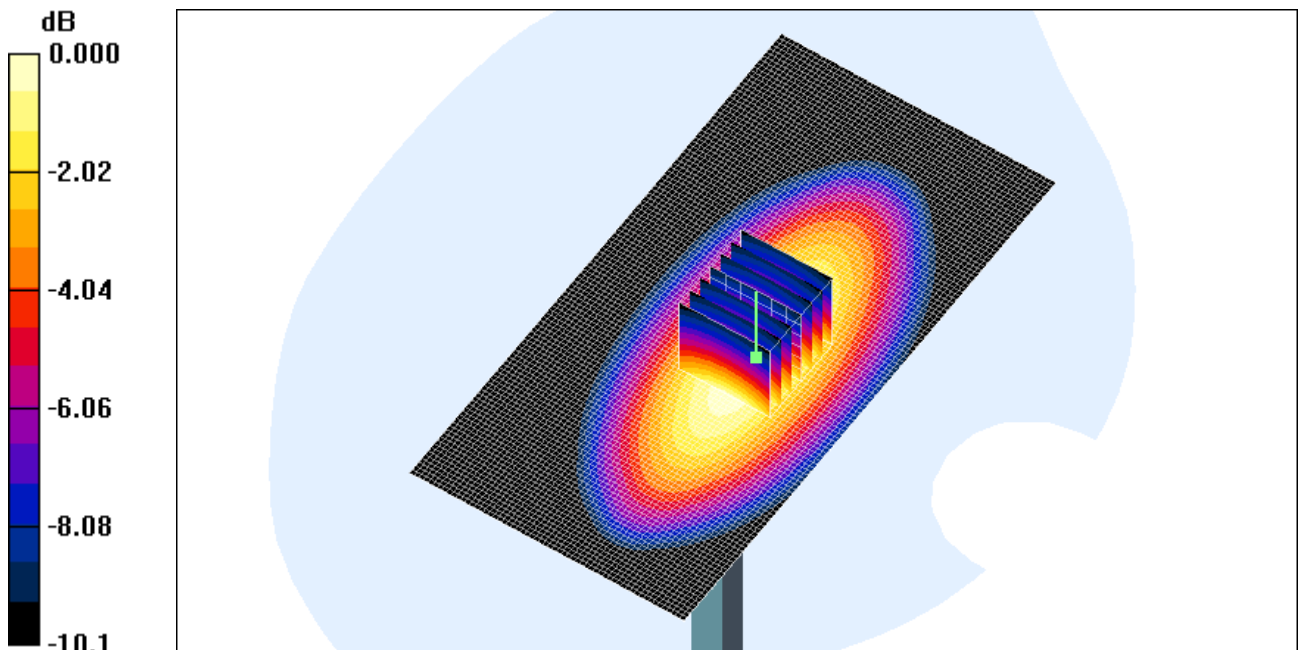
d=15mm, Pin=250mW /Zoom Scan (7x7x7) (7x7x7)/Cube 0: **Measurement grid: dx=5mm, dy=5mm, dz=5mm**

Reference Value = 52.1 V/m; Power Drift = 0.175 dB

Peak SAR (extrapolated) = 3.66 W/kg

SAR(1 g) = 2.45 mW/g; SAR(10 g) = 1.56 mW/g

Maximum value of SAR (measured) = 2.63 mW/g



0 dB = 2.63mW/g

System Validation for 1900MHz-Body

Date/Time: 2012-8-6 17:35:24

Test Laboratory: SGS-GSM

System Performance Check at 1900 MHz Body

DUT: Dipole 1900 MHz; Type: D1900V2; Serial: D1900V2 - SN:5d028

Communication System: CW; Frequency: 1900 MHz; Duty Cycle: 1:1

Medium: HSL1900-Body Medium parameters used: $f = 1900$ MHz; $\sigma = 1.52$ mho/m; $\epsilon_r = 53.4$; $\rho = 1000$ kg/m³

Phantom section: Flat Section

DASY4 Configuration:

- Probe: ES3DV3 - SN3088; ConvF(4.8, 4.8, 4.8); Calibrated: 2011-11-23
- Sensor-Surface: 4mm (Mechanical Surface Detection)
- Electronics: DAE3 Sn569; Calibrated: 2011-11-16
- Phantom: SAM 12; Type: SAM V4.0; Serial: TP-1283
- Measurement SW: DASY4, V4.7 Build 80; Postprocessing SW: SEMCAD, V1.8 Build 186

d=10mm, Pin=250mW/Area Scan (61x101x1): **Measurement grid: dx=15mm, dy=15mm**

Maximum value of SAR (interpolated) = 12.7 mW/g

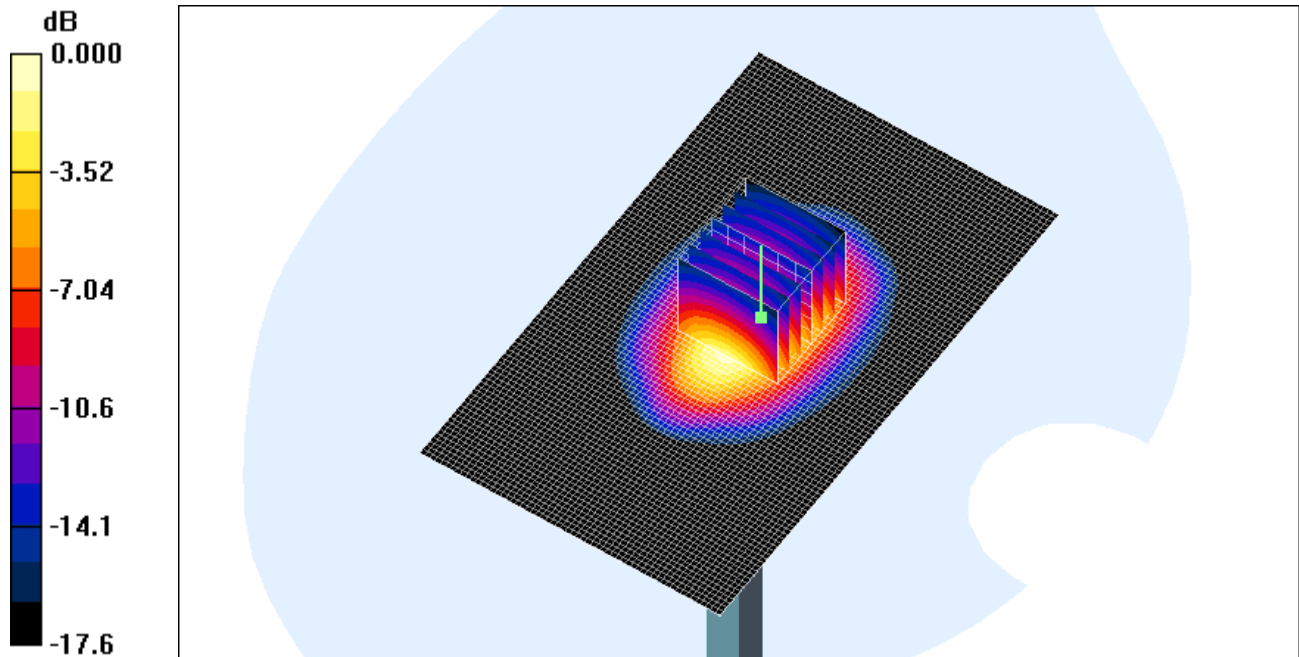
d=10mm, Pin=250mW/Zoom Scan (7x7x7) (7x7x7)/Cube 0: **Measurement grid: dx=5mm, dy=5mm, dz=5mm**

Reference Value = 77.1 V/m; Power Drift = 0.169 dB

Peak SAR (extrapolated) = 19.2 W/kg

SAR(1 g) = 10.5 mW/g; SAR(10 g) = 5.44 mW/g

Maximum value of SAR (measured) = 12.8 mW/g



0 dB = 12.8mW/g

System Performance Check at 2450MHzBody

Date/Time: 2012-8-14 8:04:40

Test Laboratory: SGS-GSM

System Performance Check at 2450MHzBody

DUT: Dipole 2450 MHz; Type: D2450V2; Serial: D2450V2 - SN:733

Communication System: CW; Frequency: 2450 MHz;Duty Cycle: 1:1

Medium: HSL2450-Body Medium parameters used: $f = 2450$ MHz; $\sigma = 2.01$ mho/m; $\epsilon_r = 51.3$; $\rho = 1000$ kg/m³

Phantom section: Flat Section

DASY4 Configuration:

- Probe: ES3DV3 - SN3088; ConvF(4.35, 4.35, 4.35); Calibrated: 2011-11-23
- Sensor-Surface: 4mm (Mechanical Surface Detection)
- Electronics: DAE3 Sn569; Calibrated: 2011-11-16
- Phantom: ELI 4.0; Type: QDOVA001BA; Serial: xxxx
- Measurement SW: DASY4, V4.7 Build 80; Postprocessing SW: SEMCAD, V1.8 Build 186

d=10mm, Pin=250mW /Area Scan (61x101x1): **Measurement grid: dx=15mm, dy=15mm**

Maximum value of SAR (interpolated) = 15.2 mW/g

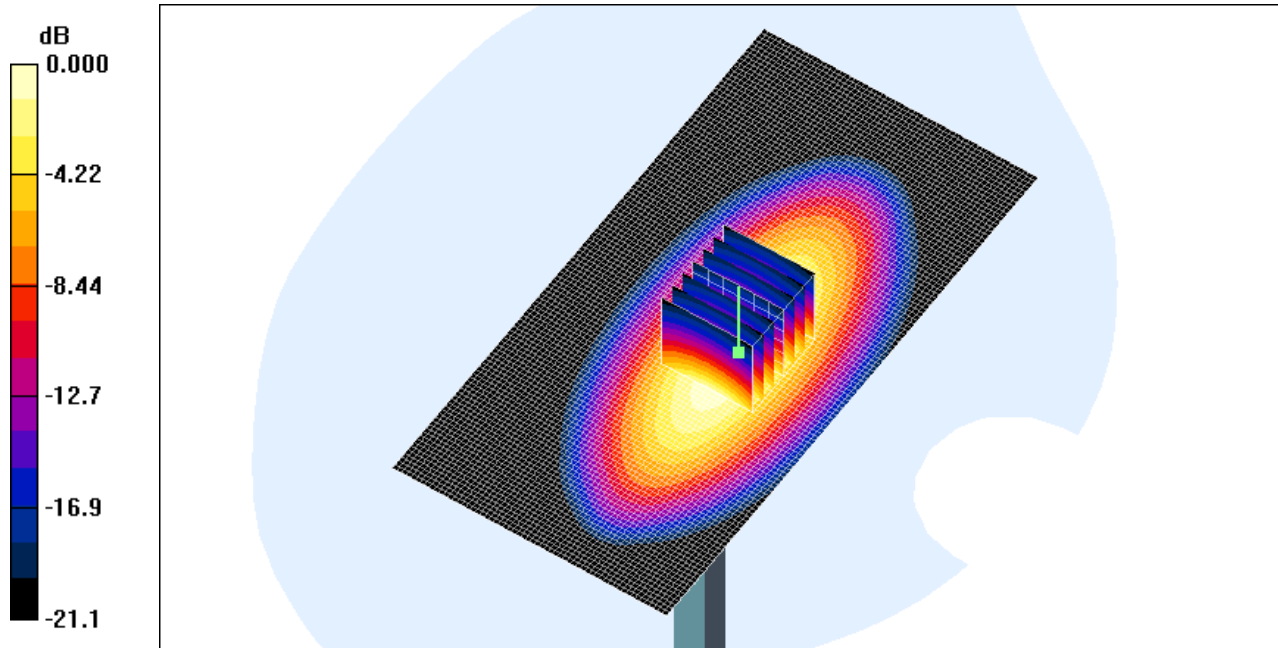
d=10mm, Pin=250mW /Zoom Scan (7x7x7) (7x7x7)/Cube 0: **Measurement grid: dx=5mm, dy=5mm, dz=5mm**

Reference Value = 83.8 V/m; Power Drift = -0.181 dB

Peak SAR (extrapolated) = 23.5W/kg

SAR(1 g) = 12.3 mW/g; SAR(10 g) = 5.75 mW/g

Maximum value of SAR (measured) = 14.1 mW/g



0 dB = 14.1mW/g