



中国认可  
国际互认  
检测  
TESTING  
CNAS L0310



# FCC&ISED RF Test Report

**Product Name: HSPA+ Module**

**Model Number: MU709s-6**

**Report No.: SYBH(Z-RF)20180824007001-2001**

**FCC ID: QISMU709S-6**

**ISED: 6369A-MU709S6**

**Reliability Laboratory of Huawei Technologies Co., Ltd.**

**(Global Compliance and Testing Center of Huawei Technologies Co., Ltd)**

Administration Building, Headquarters of Huawei Technologies Co., Ltd., Bantian, Longgang District,  
Shenzhen, 518129, P.R.C

Tel: +86 755 28780808 Fax: +86 755 89652518



## Notice

1. The laboratory has passed the accreditation by China National Accreditation Service for Conformity Assessment (CNAS). The accreditation number is L0310.
2. The laboratory has passed the accreditation by The American Association for Laboratory Accreditation (A2LA). The accreditation number is 2174.01
3. The laboratory has been recognized by the US Federal Communications Commission (FCC) to perform compliance testing subject to the Commission's Certification rules. The Designation Number is CN1173, and the Test Firm Registration Number is 294140.
4. The laboratory has been listed by Industry Canada to perform electromagnetic emission measurements. The recognition numbers of test site are 6369A-1.
5. The laboratory (Reliability Lab of Huawei Technologies Co., Ltd) is also named "Global Compliance and Testing Center of Huawei Technologies Co., Ltd", the both names have coexisted since 2009.
6. The test report is invalid if not marked with the signatures of the persons responsible for preparing and approving the test report.
7. The test report is invalid if there is any evidence of erasure and/or falsification.
8. The test report is only valid for the test samples.
9. Content of the test report, in part or in full, cannot be used for publicity and/or promotional purposes without prior written approval from the laboratory.



**Applicant:** Huawei Technologies Co., Ltd.  
**Address:** Administration Building, Headquarters of Huawei Technologies Co., Ltd.,  
 Bantian, Longgang District, Shenzhen, 518129, P.R.C

**Date of Receipt Sample:** 2018-08-30  
**Start Date of Test:** 2018-09-06  
**End Date of Test:** 2018-09-14

**Test Result:** Pass

<b>Approved by Senior Engineer:</b>	2018-09-14	He Hao	<i>He Hao</i>
	Date	Name	Signature

<b>Prepared by:</b>	2018-09-14	Mao Wenli	<i>Mao wenli</i>
	Date	Name	Signature



**CONTENT**

1 General Information .....5  
1.1 Applied Standard.....5  
1.2 Test Location.....5  
1.3 Test Environment Condition .....5  
2 Test Summary .....6  
2.1 Cellular Band (824-849 MHz paired with 869-894 MHz) .....6  
2.2 PCS Band (1850-1910 MHz paired with 1930-1990 MHz) .....8  
3 Description of the Equipment under Test (EUT) .....10  
3.1 General Description .....10  
3.2 EUT Identity .....11  
3.3 Technical Specification .....12  
4 General Test Conditions / Configurations .....13  
4.1 Test Modes .....13  
4.2 Test Environment.....13  
4.3 Test Frequency .....14  
4.4 DESCRIPTION OF TESTS .....15  
4.5 Test Setups .....21  
4.6 Test Conditions .....24  
5 Main Test Instruments .....26  
6 Measurement Uncertainty.....27  
7 Appendixes.....28



## 1 General Information

### 1.1 Applied Standard

Applied Rules: 47 CFR FCC Part 02  
47 CFR FCC Part 22  
47 CFR FCC Part 24  
ISED RSS-Gen Issue 5,  
ISED RSS-132 Issue 3,  
ISED RSS-133 Issue 6,

Test Method: FCC KDB 971168 D01 Power Meas License Digital Systems v03r01

### 1.2 Test Location

Test Location : Reliability Laboratory of Huawei Technologies Co., Ltd.  
Address: No.2 New City Avenue Songshan Lake Sci. &Tech. Industry Park, Dongguan,  
Guangdong, P.R.C

### 1.3 Test Environment Condition

Ambient Temperature: 19.5 to 25 °C  
Ambient Relative Humidity: 40 to 55 %  
Atmospheric Pressure: Not applicable



## 2 Test Summary

### 2.1 Cellular Band (824-849 MHz paired with 869-894 MHz)

Test Item	FCC Rule No.	ISED Rule No.	Requirements	Test Result	Verdict (Note1)
Effective (Isotropic) Radiated Power Output Data	§2.1046, §22.913	RSS-Gen, §6.12; RSS-132, §5.4	FCC: ERP ≤ 7 W. ISED: EIRP ≤ 11.5 W.	Appendix A	PASS
Peak-Average Ratio	---	RSS-132, §5.4	Limit ≤ 13 dB	Appendix B	PASS
Modulation Characteristics	§2.1047	RSS-132, §5.2	Digital modulation	Appendix C	PASS
Bandwidth	§2.1049	RSS-Gen, §6.7	OBW: No limit. EBW: No limit.	Appendix D	PASS
Band Edges Compliance	§2.1051, §22.917	RSS-Gen, §6.13; RSS-132, §5.5	FCC: ≤ -13 dBm/1%*EBW, in 1 MHz bands immediately outside and adjacent to the frequency block.  Note 1): EBW is -26 dBc EBW.  ISED: ≤ -13 dBm/1%*OBW, in 1 MHz bands immediately outside and adjacent to the sub-bands.	Appendix E	PASS
Spurious Emission at Antenna Terminals	§2.1051, §22.917	RSS-Gen, §6.13; RSS-132, §5.5	FCC: ≤ -13 dBm/RefBW, from max( lowest internal frequency, 9 kHz ) to min( 10 * highest fundamental frequency, 40 GHz), after 1 MHz bands immediately outside and adjacent to the frequency block. (RefBW: ≥100 kHz for frequency below 1 GHz, and =1 MHz above 1 GHz) ISED: ≤ -13 dBm/100 kHz, from max( min( lowest internal frequency, 30 MHz ), 9 kHz ) to min( 10 * highest fundamental frequency, 40 GHz), after first 1.0 MHz immediately outside and adjacent to each of the sub-bands.	Appendix F	PASS
Field Strength of	§2.1053,	RSS-Gen,	FCC: ≤ -13 dBm/RefBW, from	Appendix G	PASS



Test Item	FCC Rule No.	ISED Rule No.	Requirements	Test Result	Verdict (Note1)
Spurious Radiation	§22.917	§6.13; RSS-132, §5.5	max( lowest internal frequency, 9 kHz ) to min( 10 * highest fundamental frequency, 40 GHz), after 1 MHz bands immediately outside and adjacent to the frequency block. (RefBW: ≥100 kHz for frequency below 1 GHz, and =1 MHz above 1 GHz) ISED: ≤ -13 dBm/100 kHz, from max( min( lowest internal frequency, 30 MHz ), 9 kHz ) to min( 10 * highest fundamental frequency, 40 GHz), after first 1.0 MHz immediately outside and adjacent to each of the sub-bands.		
Frequency Stability	§2.1055, §22.355	RSS-Gen, §6.11 RSS-132, §5.3	≤ ±2.5ppm	Appendix H	PASS

**2.2 PCS Band (1850-1910 MHz paired with 1930-1990 MHz)**

Test Item	FCC Rule No.	ISED Rule No.	Requirements	Test Result	Verdict (Note1)
Effective (Isotropic) Radiated Power Output Data	§2.1046, §24.232	RSS-Gen, §6.12; RSS-133, §6.4	EIRP ≤ 2 W	Appendix A	PASS
Peak-Average Ratio	§2.1046, §24.232	RSS-133, §6.4	Limit≤13 dB	Appendix B	PASS
Modulation Characteristics	§2.1047	RSS-133, §6.2	Digital modulation	Appendix C	PASS
Bandwidth	§2.1049	RSS-Gen, §6.7	OBW: No limit. EBW: No limit.	Appendix D	PASS
Band Edges Compliance	§2.1051, §24.238	RSS-Gen, §6.13; RSS-133, §6.5	FCC: ≤ -13 dBm/1%*EBW, in 1 MHz bands immediately outside and adjacent to the frequency block.  Note 1): EBW is -26 dBc EBW.  ISED: ≤ -13 dBm/1%*EBW, in 1 MHz bands immediately outside and adjacent to the frequency block.  Note 1): EBW is -20 dBc EBW, or OBW.	Appendix E	PASS
Spurious Emission at Antenna Terminals	§2.1051, §24.238	RSS-Gen, §6.13; RSS-133, §6.5	FCC: ≤ -13 dBm/1 MHz, from max( lowest internal frequency, 9 kHz ) to min( 10 * highest fundamental frequency, 40 GHz ) but outside authorized operating frequency blocks. ISED: ≤ -13 dBm/1 MHz, from max( min( lowest internal frequency, 30 MHz ), 9 kHz ) to min( 10 * highest fundamental frequency, 40 GHz ) but outside authorized operating frequency blocks.	Appendix F	PASS
Field Strength of Spurious	§2.1053, §24.238	RSS-Gen, §6.13;	FCC: ≤ -13 dBm/1 MHz, from max( lowest internal frequency, 9	Appendix G	PASS





Test Item	FCC Rule No.	ISED Rule No.	Requirements	Test Result	Verdict (Note1)
Radiation		RSS-133, §6.5	kHz ) to min( 10 * highest fundamental frequency, 40 GHz) but outside authorized operating frequency blocks.  ISED: $\leq -13$ dBm/1 MHz, from max( min( lowest internal frequency, 30 MHz ), 9 kHz ) to min( 10 * highest fundamental frequency, 40 GHz) but outside authorized operating frequency blocks.		
Frequency Stability	§2.1055, §24.235	RSS-Gen, §6.11 RSS-133, §6.3	FCC: Within authorized bands of operation/frequency block.  ISED $\leq \pm 2.5$ ppm	Appendix H	PASS

### 3 Description of the Equipment under Test (EUT)

#### 3.1 General Description

MU709s-6 WCDMA/HSDPA/HSUPA/HSPA+/GSM/GPRS/EDGE mode Wireless Module is subscriber equipment in the system. MU709s-6 implement such functions as RF signal receiving/transmitting,WCDMA/HSDPA/HSUPA/HSPA/GSM/GPRS/EDGE protocol processing, data service etc.

MU709s-6, there are two interface that is PCIE and LGA

The following table shows the differences between the PCIE and LGA, There is only interface different from LGA interface and PCIE interface for MU709s-6.

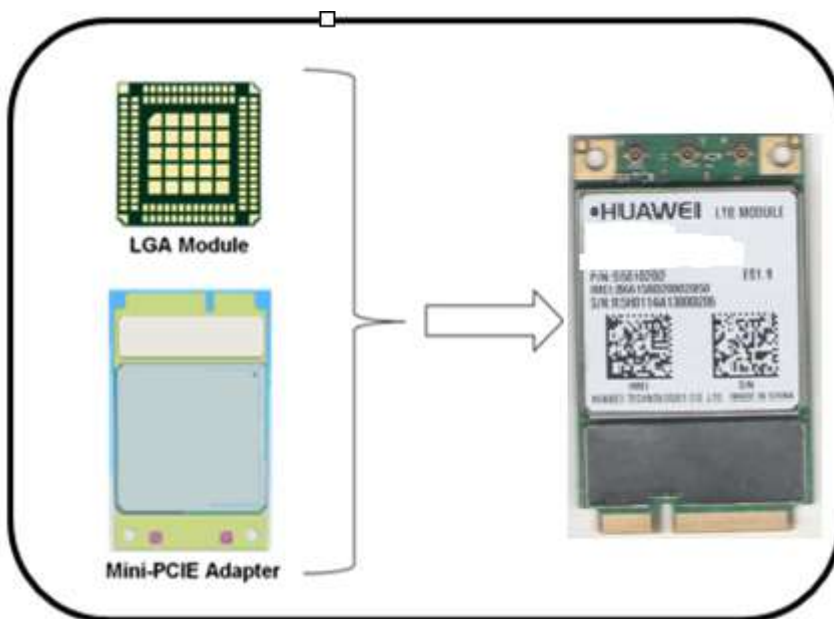

Items	PCIE	LGA	Difference points
Working bands	The same	The same	No Differences
Power Voltage	3.0V-3.6V(Typical value 3.3V)	3.3V-4.2V(Typical 3.8V)	The power supply voltage is different ,Actually the voltage to LGA chip is the same
Interface	PCie interfaces	145-pin LGA interface	The interface is different
Working temperature	The same(-20~+70°C)	The same(-20~+70°C)	No Differences

NOTE: For PCIE, we didn't test it except Field Strength of Spurious Radiation , all test data except Field Strength of Spurious Radiation refer to No. SYBH(Z-RF)20180810006001-2001 of MU709s-6 of LGA.



### 3.2 EUT Identity

NOTE: Unless otherwise noted in the report, the functional boards installed in the units shall be selected from the below list, but not means all the functional boards listed below shall be installed in one unit.

#### 3.2.1 Board

Board		
Description	Hardware Version	Software Version
Main Board	MD1MU709M01	11.652.75.00.00



### 3.3 Technical Specification

Characteristics	Description	
Radio System Type	<input checked="" type="checkbox"/> UMTS	
Supported Frequency Range	WCDMA850	Transmission (TX): 824 to 849 MHz
		Receiving (RX): 869 to 894 MHz
	WCDMA1900	Transmission (TX): 1850 to 1910 MHz
		Receiving (RX): 1930 to 1990 MHz
TX and RX Antenna Ports	TX & RX port:	1
	TX-only port:	0
	RX-only port:	1
Target TX Output Power	UMTS850 23.5dBm UMTS1900: 23.5dBm	
	UMTS system:	<input checked="" type="checkbox"/> 5 MHz
Designation of Emissions (Note: the necessary bandwidth of which is the worst value from the measured occupied bandwidths for each type of channel bandwidth configuration.)	UMTS850:	4M16F9W
	UMTS1900:	4M16F9W



## 4 General Test Conditions / Configurations

### 4.1 Test Modes

NOTE: The test mode(s) are selected according to relevant radio technology specifications.

Test Mode	Test Modes Description
UMTS/TM1	WCDMA system, QPSK modulation

### 4.2 Test Environment

Environment Parameter	Selected Values During Tests	
Relative Humidity	Ambient	
Temperature	TN	Ambient
Voltage	VL	3.0V
	VN	3.3V
	VH	3.6V

NOTE: VL= lower extreme test voltage  
VN= nominal voltage  
VH= upper extreme test voltage  
TN= normal temperature



### 4.3 Test Frequency

Test Mode	TX / RX	RF Channel		
		Low (L)	Middle (M)	High (H)
WCDMA850	TX	Channel 4132	Channel 4182	Channel 4233
		826.4MHz	836.4MHz	846.6MHz
	RX	Channel 4357	Channel 4407	Channel 4458
		871.4MHz	881.4MHz	891.6MHz
Test Mode	TX / RX	RF Channel		
		Low (L)	Middle (M)	High (H)
WCDMA1900	TX	Channel 9262	Channel9400	Channel9538
		1852.4MHz	1880.0MHz	1907.6MHz
	RX	Channel 9662	Channel 9800	Channel 9938
		1932.4 MHz	1960.0 MHz	1987.6 MHz



## 4.4 DESCRIPTION OF TESTS

### 4.4.1 Radiated Power and Radiated Spurious Emissions

Radiated spurious emissions are investigated indoors in a full-anechoic chamber to determine the frequencies producing the worst case emissions. Final measurements for radiated power and radiated spurious emissions are performed on the 3 meter OATS per the guidelines of ANSI/TIA-603-E-2016. The equipment under test was transmitting while connected to its integral antenna and is placed on a wooden turntable 150cm above the ground plane and 3 meters from the receive antenna. The spectrum is scanned from the lowest frequency generated in the equipment up to a frequency including its 10th harmonic. The receive antenna height is adjusted between 1 and 4 meter height, the turntable is rotated through 360 degrees, and the EUT is manipulated through all orthogonal planes representative of its typical use to achieve the highest reading on the receive spectrum analyzer. Emissions are also investigated with the receive antenna horizontally and vertically polarized.

A portable or small unlicensed wireless device shall be placed on a non-metallic test fixture or other non-metallic support during testing. The supporting fixture shall permit orientation of the EUT in each of three orthogonal (x, y, z) axis positions such that emissions from the EUT are maximized. Measure the EUT maximum RF power and record the result.

A half-wave dipole is then substituted in place of the EUT. For emissions above 3GHz, a horn antenna is substituted in place of the EUT. The substitute antenna is driven by a signal generator with the level of the signal generator being adjusted to obtain the same receive spectrum analyzer level previously recorded from the spurious emission from the EUT.

The power of the emission is calculated using the following formula:

$$P_d [\text{dBm}] = P_g [\text{dBm}] - \text{cable loss} [\text{dB}] + \text{antenna gain} [\text{dBd/dBi}]$$

Where,  $P_d$  is the dipole equivalent power,  $P_g$  is the generator output into the substitution antenna, and the antenna gain is the gain of the substitute antenna used relative to either a half-wave dipole (dBd) or an isotropic source (dBi). The substitute level is equal to  $P_g [\text{dBm}] - \text{cable loss} [\text{dB}]$ .

The calculated  $P_d$  levels are then compared to the absolute spurious emission limit of -13dBm which is equivalent to the required minimum attenuation of  $43 + 10\log_{10}(\text{Power} [\text{Watts}])$ .

### Test Procedures Used

KDB 971168 D01-Section 5.2.2 / KDB 971168 D01-Section 5.8

ANSI/TIA-603-E-2016-Section 2.2.17 / ANSI/TIA-603-E-2016-Section 2.2.12

Note: Reference test setup 3



#### 4.4.2 Peak-Average Ratio

A peak to average ratio measurement is performed at the conducted port of the EUT. The spectrum analyzers Complementary Cumulative Distribution Function (CCDF) measurement profile is used to determine the largest deviation between the average and the peak power of the EUT in a given bandwidth.

##### Test Procedures Used

KDB 971168 D01-Section 5.7.2

##### Test Settings

- 1、 The signal analyzer's CCDF measurement profile enabled
- 2、 Frequency= carrier center frequency
- 3、 Measurement BW > EBW of signal
- 4、 for continuous transmissions, set to 1ms
- 5、 Record the maximum PAPR level associated with a probability of 0.1%.

Note: Reference test setup 1





### 4.4.3 Occupied Bandwidth

The occupied bandwidth, that is the frequency bandwidth such that, below its lower and above its upper frequency limits, the mean powers radiated are each equal to 0.5 percent of the total mean power radiated by a given emission shall be measured. The span of the analyzer shall be set to capture all products of the modulation process, including the emission skirts. The resolution bandwidth shall be set to as close to 1 percent of the selected span as is possible without being below 1 percent. The video bandwidth shall be set to 3 times the resolution bandwidth. Video averaging is not permitted. Where practical, a sampling detector shall be used since a peak or, peak hold, may produce a wider bandwidth than actual. The trace data points are recovered and are directly summed in linear terms. The recovered amplitude data points, beginning at the lowest frequency, are placed in a running sum until 0.5 percent of the total is reached and that frequency recorded. The process is repeated for the highest frequency data points. This frequency is recorded. The span between the two recorded frequencies is the occupied bandwidth.

#### Test Procedures Used

KDB 971168 D01-Section 4.3

#### Test Settings

- 1、 SET RBW=1-5% of OBW
- 2、 SET VBW  $\geq$  3\*RBW
- 3、 Detector: Peak
- 4、 Trace mode= max hold.
- 5、 Sweep= auto couple
- 6、 Steps 1-5 were repeated after it is stable

Note: Reference test setup 1.



#### **4.4.4 Band Edge Compliance**

The test complies with the requirements in clause 2 of the present report according to test procedures in KDB 971168 D01-Section 6 with corresponding test settings.

Note: Reference test setup 1.



#### **4.4.5 Spurious and Harmonic Emissions at Antenna Terminal**

The test complies with the requirements in clause 2 of the present report according to test procedures in KDB 971168 D01-Section 6 with corresponding test settings.

Note: Reference test setup 1.



#### 4.4.6 Frequency Stability / Temperature Variation

Frequency stability testing is performed in accordance with the guidelines of ANSI/TIA-603-E-2016. The frequency stability of the transmitter is measured by:

- a.) **Temperature:** The temperature is varied from -30°C to +50°C in 10°C increments using an environmental chamber.
- b.) **Primary Supply Voltage:** The primary supply voltage is varied from 85% to 115% of the nominal value for non hand-carried battery and AC powered equipment. For hand-carried, battery-powered equipment, primary supply voltage is reduced to the battery operating end point which shall be specified by the manufacturer.

Specification – The frequency stability shall be sufficient to ensure that the fundamental emission stays within the authorized frequency block. The frequency stability of the transmitter shall be maintained within  $\pm 0.00025\%$  ( $\pm 2.5$  ppm) of the center frequency.

**Time Period and Procedure:**

1. The carrier frequency of the transmitter is measured at room temperature (20°C to provide a reference).
2. The equipment is turned on in a “standby” condition for fifteen minutes before applying power to the transmitter. Measurement of the carrier frequency of the transmitter is made within one minute after applying power to the transmitter.
3. Frequency measurements are made at 10°C intervals ranging from -30°C to +50°C. A period of at least one half-hour is provided to allow stabilization of the equipment at each temperature level.

**Test Procedures Used**

ANSI/TIA-603-E-2016

Note: Reference test setup 2.

## 4.5 Test Setups

### 4.5.1 Test Setup 1

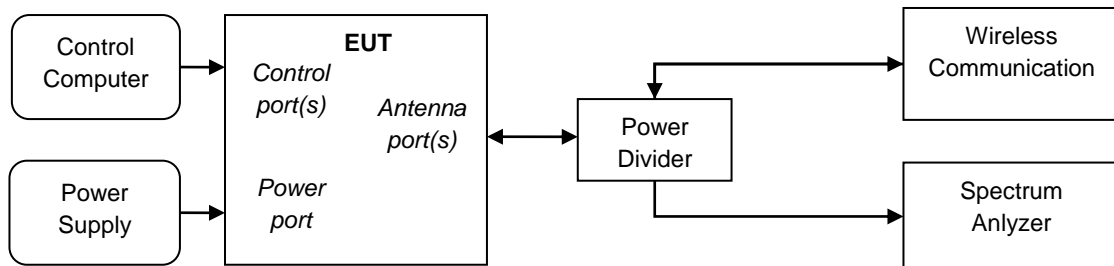

#### 4.5.2 Test Setup 2

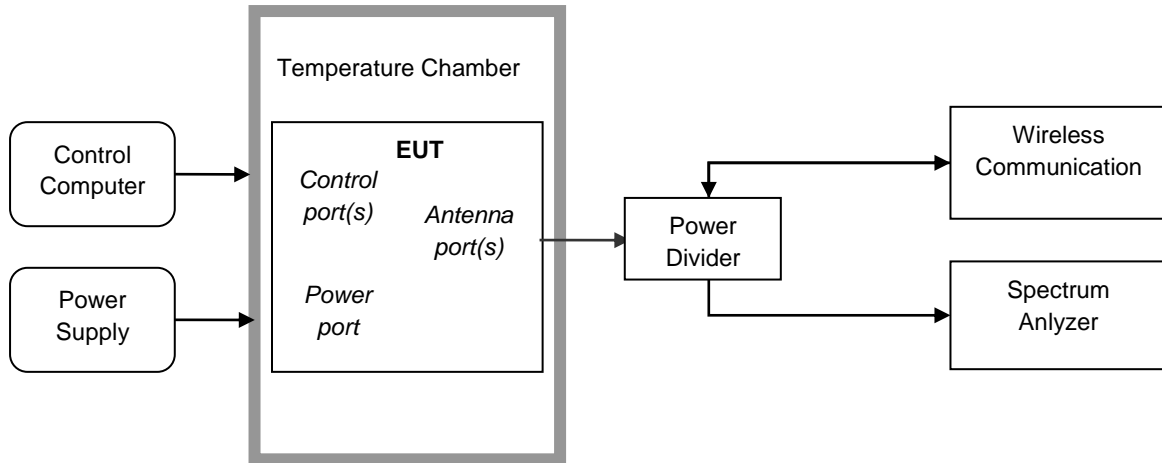

### 4.5.3 Test Setup 3

NOTE: Effective radiated power (ERP) and Equivalent Isotropic Radiated Power(EIRP) refers to the radiation power output of the EUT, assuming all emissions are radiated from half-wave dipole antennas.

#### 4.5.3.1 Step 1: Pre-test

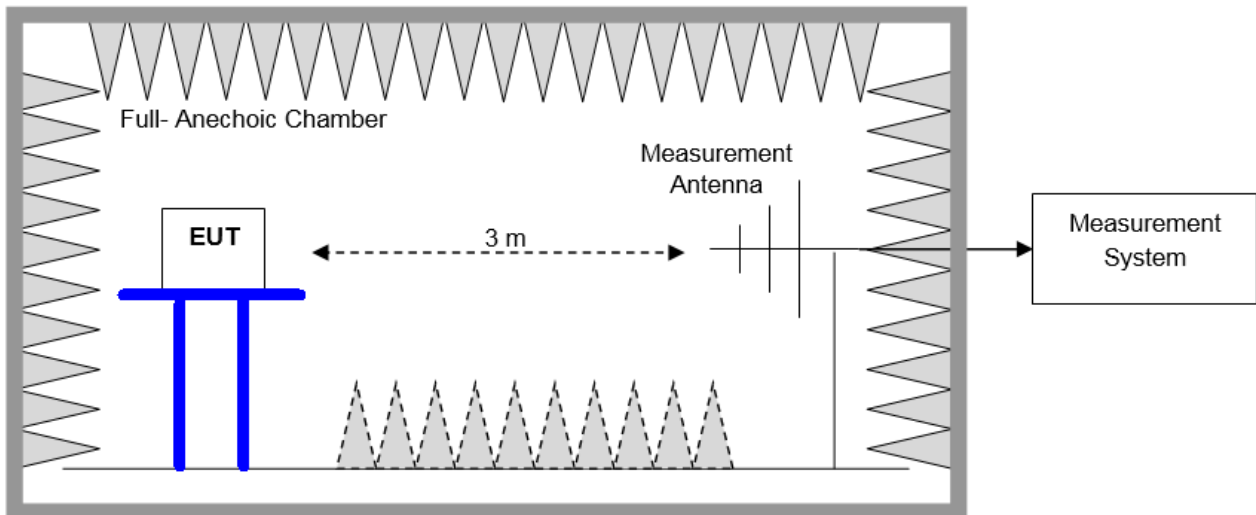

#### 4.5.3.2 Step 2: Substitution method to verify the maximum ERP/EIRP

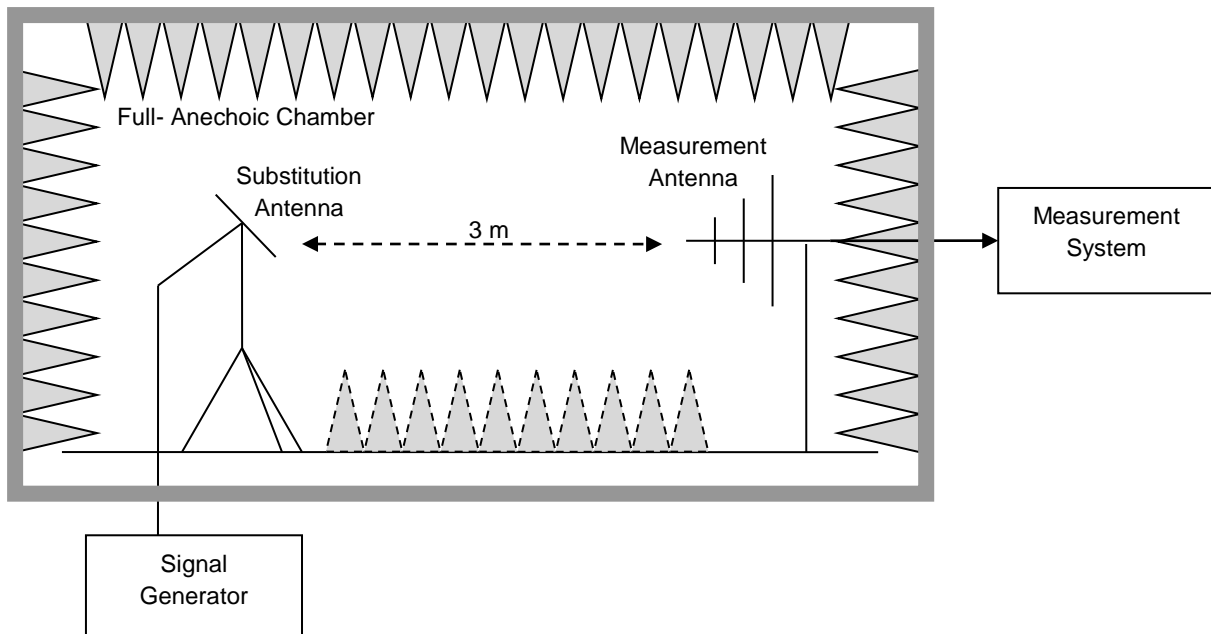



## 4.6 Test Conditions

Test Case		Test Conditions	
Transmit Output Power Data	Average Power, Total	Test Env.	Ambient Climate & Rated Voltage
		Test Setup	Test Setup 1
		RF Channels (TX)	L, M, H (L= low channel, M= middle channel, H= high channel )
		Test Mode	UMTS/TM1
	Average Power, Spectral Density (if required)	Test Env.	Ambient Climate & Rated Voltage
		Test Setup	Test Setup 1
		RF Channels (TX)	L, M, H (L= low channel, M= middle channel, H= high channel )
		Test Mode	UMTS/TM1
Peak-to-Average Ratio (if required)		Test Env.	Ambient Climate & Rated Voltage
		Test Setup	Test Setup 1
		RF Channels (TX)	L, M, H (L= low channel, M= middle channel, H= high channel )
		Test Mode	UMTS/TM1
Modulation Characteristics		Test Env.	Ambient Climate & Rated Voltage
		Test Setup	Test Setup 1
		RF Channels (TX)	M (L= low channel, M= middle channel, H= high channel )
		Test Mode	UMTS/TM1
Bandwidth	Occupied Bandwidth	Test Env.	Ambient Climate & Rated Voltage
		Test Setup	Test Setup 1
		RF Channels (TX)	L, M, H (L= low channel, M= middle channel, H= high channel )
		Test Mode	UMTS/TM1
	Emission Bandwidth (if required)	Test Env.	Ambient Climate & Rated Voltage
		Test Setup	Test Setup 1
		RF Channels (TX)	L, M, H (L= low channel, M= middle channel, H= high channel )
		Test Mode	UMTS/TM1
Band Edges Compliance		Test Env.	Ambient Climate & Rated Voltage
		Test Setup	Test Setup 1
		RF Channels (TX)	L, H (L= low channel, M= middle channel, H= high channel )
		Test Mode	UMTS/TM1
Spurious Emission at Antenna Terminals		Test Env.	Ambient Climate & Rated Voltage
		Test Setup	Test Setup 1
		RF Channels (TX)	L, M, H (L= low channel, M= middle channel, H= high channel )





Test Case	Test Conditions	
	Test Mode	UMTS/TM1
Field Strength of Spurious Radiation	Test Env.	Ambient Climate & Rated Voltage
	Test Setup	Test Setup 3
	Test Mode	UMTS/TM1 NOTE: If applicable, the EUT conf. that has maximum power density (based on the equivalent power level) is selected.
	RF Channels (TX)	L, M, H (L= low channel, M= middle channel, H= high channel )
Frequency Stability	Test Env.	(1) -30 °C to +50 °C with step 10 °C at Rated Voltage; (2) VL, VN and VH of Rated Voltage at Ambient Climate.
	Test Setup	Test Setup 2
	RF Channels (TX)	L, M, H (L= low channel, M= middle channel, H= high channel )
	Test Mode	UMTS/TM1

**5 Main Test Instruments****Conducted:**

Main Test Equipments					
Equipment Name	Manufacturer	Model	Serial Number	Cal Date	Cal- Due
Power supply	KEITHLEY	2303	000500E	2018/05/21	2019/05/20
Universal Radio Communication Tester	R&S	CMU200	117341	2018/4/27	2019/4/26
Spectrum Analyzer	Agilent	N9030A	MY49431698	2018/7/23	2019/7/23

**Radiation:**

Main Test Equipments					
Equipment Name	Manufacturer	Model	Serial Number	Cal Date	Cal- Due
Universal Radio Communication Tester	R&S	CMU200	117385	2018/05/08	2019/05/07
Universal Radio Communication Tester	R&S	MT8821C	6261760791	2017/10/06	2018/10/05
Test receiver	R&S	ESU26	100387	2018/1/20	2019/1/19
Test receiver	R&S	ESCI	101163	2018/1/20	2019/1/19
Test receiver	R&S	ESU26	100150	2018/1/20	2019/1/19
Spectrum analyzer	R&S	FSU3	200474	2018/1/20	2019/1/19
Spectrum analyzer	R&S	FSU43	100144	2018/1/20	2019/1/19
LOOP Antennas(9kHz-30MHz)	R&S	HFH2-Z2	100262	2017/6/15	2019/6/14
LOOP Antennas(9kHz-30MHz)	R&S	HFH2-Z2	100263	2017/8/21	2019/8/20
Trilog Broadband Antenna (30M~3GHz)	SCHWARZBECK	VULB 9163	9163-490	2017/3/29	2019/3/28
Trilog Broadband Antenna (30M~3GHz)	SCHWARZBECK	VULB 9163	9163-521	2018/4/9	2020/4/8
Trilog Broadband Antenna (30M~3GHz)	SCHWARZBECK	VULB 9163	9163-357	2017/4/21	2019/4/20
Double-Ridged Waveguide Horn Antenna (1G~18GHz)	R&S	HF907	100304	2017/5/27	2019/5/26
double ridged horn antenna (0.8G-18GHz)	R&S	HF907	100305	2017/4/21	2019/4/20
Pyramidal Horn Antenna(18GHz-26.5GHz)	ETS-Lindgren	3160-09	5140299	2017/7/20	2019/7/19
Pyramidal Horn Antenna(26.5GHz-40GHz)	ETS-Lindgren	3160-10	00205695	2018/4/20	2020/4/19
Pyramidal Horn Antenna(26.5GHz-40GHz)	ETS-Lindgren	3160-10	LM5947	2017/7/20	2019/7/19
Artificial Main Network	R&S	ENV4200	100134	2018/5/8	2019/5/7
Line Impedance Stabilization Network	R&S	ENV216	100382	2018/5/8	2019/5/7

**Software Information**



Test Item	Software Name	Manufacturer	Version
RSE	EMC32	R&S	V8.40.0

## 6 Measurement Uncertainty

For a 95% confidence level ( $k = 2$ ), the measurement expanded uncertainties for defined systems, in accordance with the recommendations of ISO 17025 as following:

Test Item		Extended Uncertainty
Transmit Output Power Conducted	Power [dBm]	U = 0.64 dB
RF Power Density, Conducted	Power [dBm]	U = 0.64 dB
Bandwidth	Magnitude [kHz]	200kHz: U=9.06kHz 1.4MHz: U=9.48kHz 3MHz: U=10.86kHz 5MHz: U=13.84kHz 10MHz: U=22.32kHz 15MHz: U=31.9kHz 20MHz: U=41.78kHz
Band Edge Compliance	Disturbance Power [dBm]	U = 0.9 dB
Spurious Emissions, Conducted	Disturbance Power [dBm]	20MHz~3.6GHz: U=0.88dB 3.6GHz~8.4GHz: U=1.08dB 8.4GHz~13.6GHz: U=1.24dB 13.6GHz~22GHz: U=1.34dB 22GHz~26.5GHz: U=1.36dB
Field Strength of Spurious Radiation	ERP/EIRP [dBm]	For 3 m Chamber: U = 5.94 dB (30 MHz to 3GHz) U = 5.54 dB (3GHz to 18GHz) U = 4.94 dB (18GHz to 26.5GHz)
Frequency Stability	Frequency Accuracy [Hz]	800MHz: U=24.08Hz 900MHz: U=24.54Hz 1900MHz: U=34.7Hz 2100MHz: U=36.96Hz 2300MHz: U=39.24Hz 2500MHz: U=41.58Hz 2600MHz: U=42.74Hz



## 7 Appendixes

Appendix No.	Description
SYBH(Z-RF)20180824007001-2001-A	Appendix for WCDMA

Appendix	Description
Appendix A	Effective (Isotropic) Radiated Power Output Data
Appendix B	Peak-Average Ratio
Appendix C	Modulation Characteristics
Appendix D	Bandwidth
Appendix E	Band Edges Compliance
Appendix F	Spurious Emission at Antenna Terminals
Appendix G	Field Strength of Spurious Radiation
Appendix H	Frequency Stability

---

END