

BB SCHEMATICS

1. Contents
2. PM7540 Charging and Power Supply
3. PM7540 OTHER FUNCTIONS
4. MSM7625 GPIO Data UI and Other Interface
5. MSM7625 POWER and GROUND
6. MSM7625 Memory Interface
7. Memory
8. MSM7625 GPIOs and All Peripheral Interface
9. LCD interface
10. Camera
11. Acoustic Part Include MIC/Vibrator/Speaker
12. SIM/TF Card
13. Jog-ball and Array of Keypad
14. USB, Headset circuit
15. Test Points & Shield Covers
16. ACCELERATOR & FM
17. GPIO Mapping 1
18. GPIO Mapping 2
19. POWER TREE
20. SPECIAL

RF SCHEMATICS

- 1 RF INPUT OUPUT PORTS
- 22 19.2MHz VCTCXO
23. PRX CIRCUIT
24. TX CELL DUPLEXER & PA
25. NC
26. NC
27. GPS FRONT-END
28. RTR 6500
29. RTR6500 POWER DISTRIBUTION
30. NC
31. RX INTERSTAGE SAW FILTER
32. Bluetooth
33. AR6002 POWER AND CONTROL
34. RF TRANSCEIVER_WIFI
35. TX PA_WIFI

The type and specification of the components refer to the BOM

				NA	2009-04-26
				ECA NO	DATE
DESIGNED	JI JIANGHUI 66114	HC1M860M		00597618	
REVIEWED	XU XUESONG 57251	VER	PART_NUMBER	SHEET 1 OF 34	
			03020VQA	HUAWEI TECH CO.,LTD.	

2. PM7540 Charging and Power Supply

PM7540 Power Interface

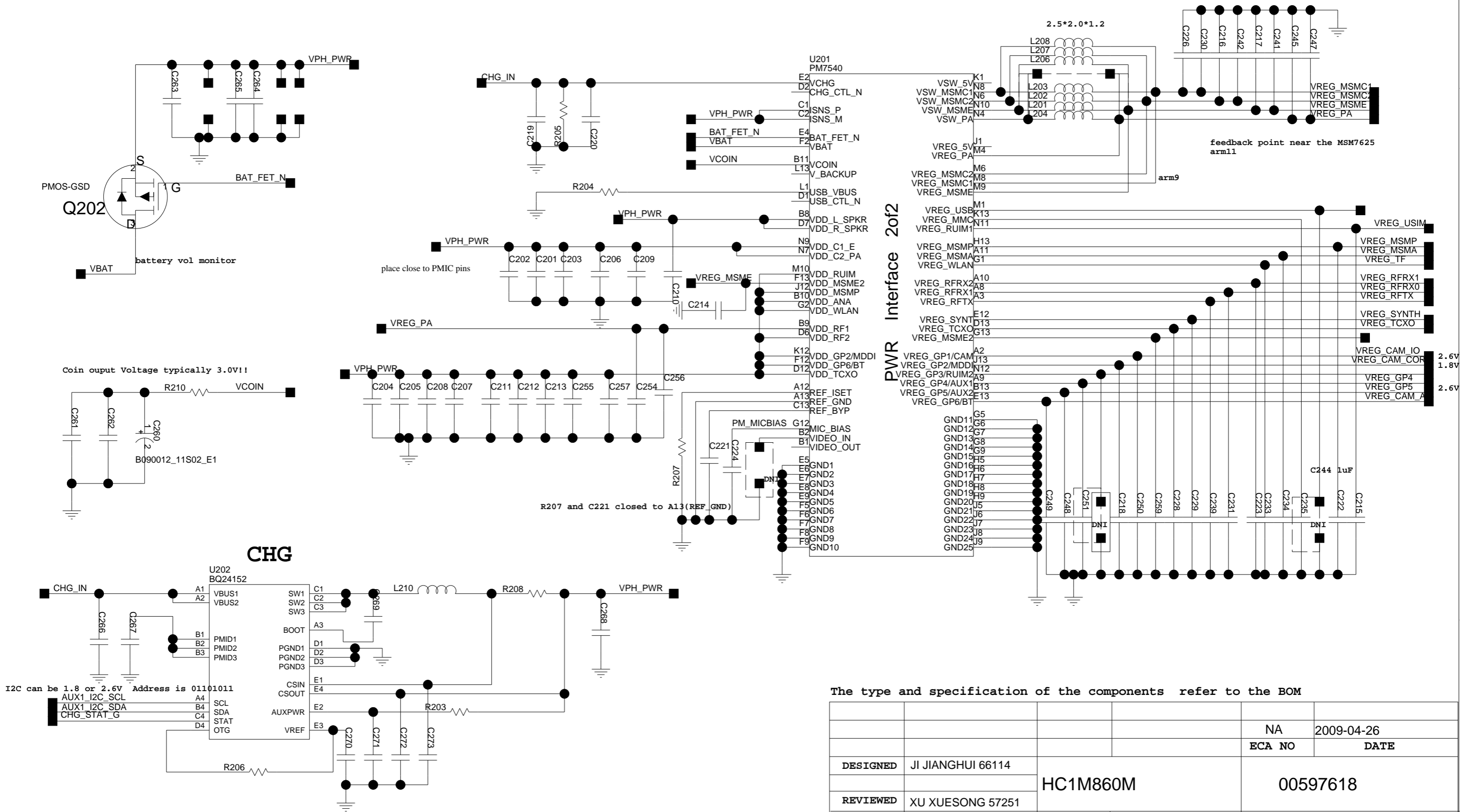

The type and specification of the components refer to the BOM

				NA	2009-04-26
				ECA NO	DATE
DESIGNED	JI JIANGHUI 66114	HC1M860M		00597618	
REVIEWED	XU XUESONG 57251	VER	PART_NUMBER	SHEET 2 OF 34	
			03020VQA	HUAWEI TECH CO.,LTD.	

3. PM7540 OTHER FUNCTIONS

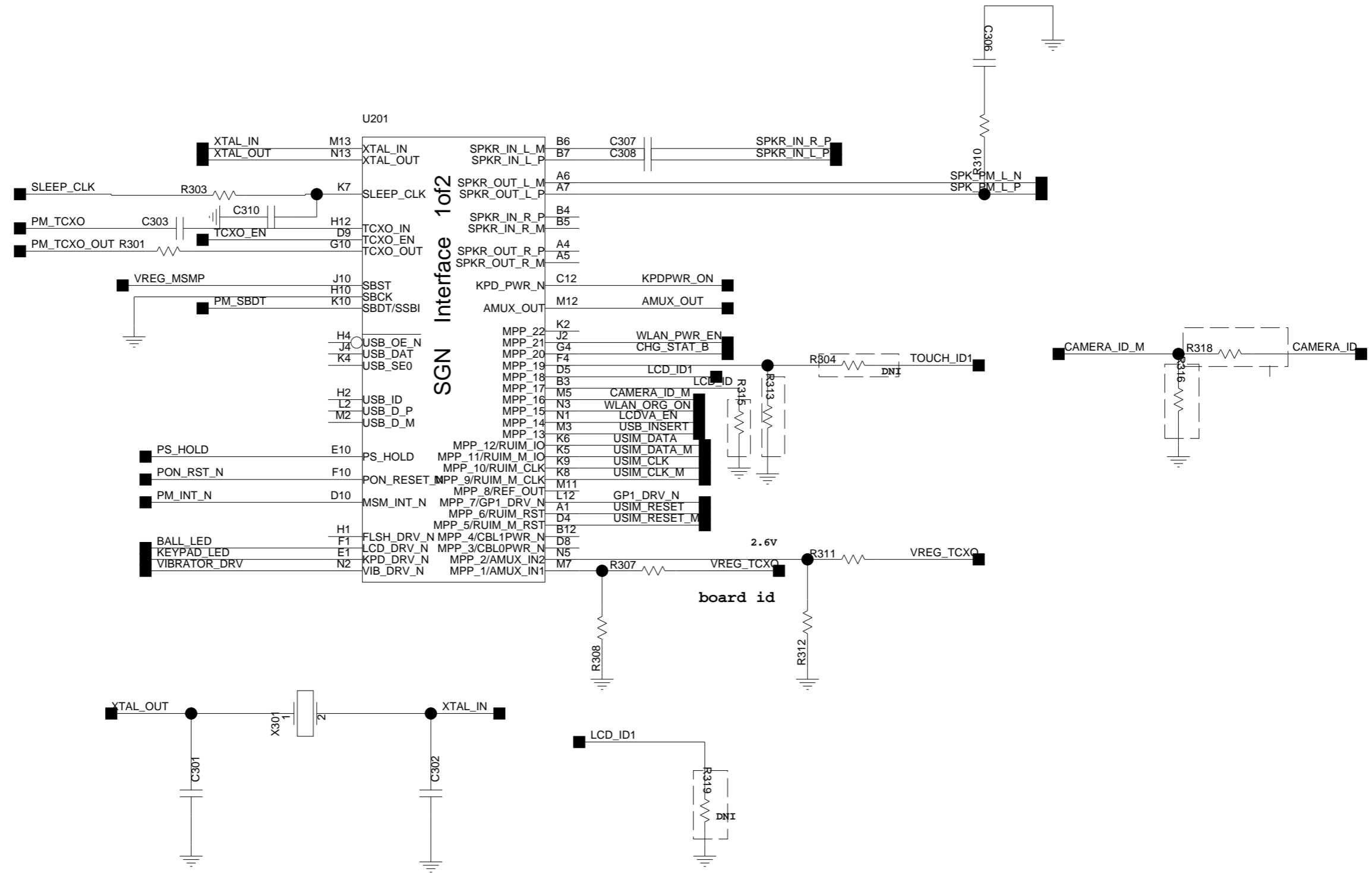

The type and specification of the components refer to the BOM

				NA	2009-04-26
				ECA NO	DATE
DESIGNED	JI JIANGHUI 66114	HC1M860M		00597618	
REVIEWED	XU XUESONG 57251	VER	PART_NUMBER	SHEET 3 OF 34	
			03020VQA	HUAWEI TECH CO.,LTD.	

4. MSM7625 ANANLOG AND RF INTERFACE

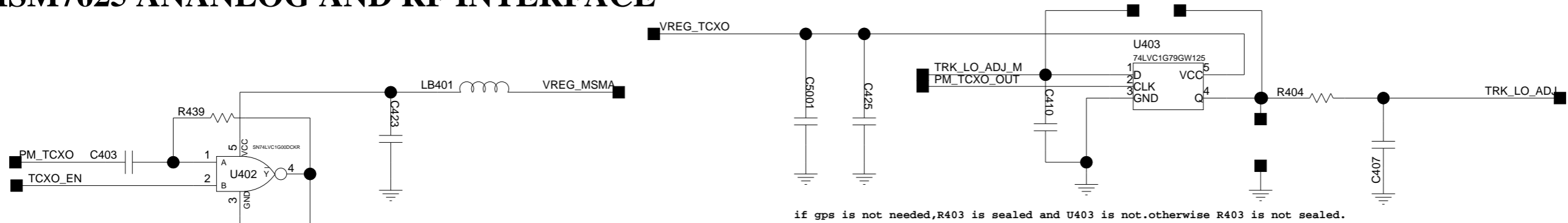

if gps is not needed,R403 is sealed and U403 is not.otherwise R403 is not sealed.

NOTE:C408 should be place to the MSM7625

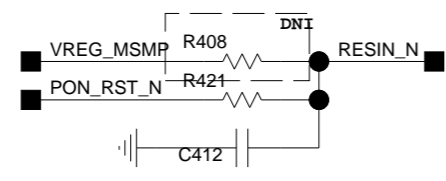
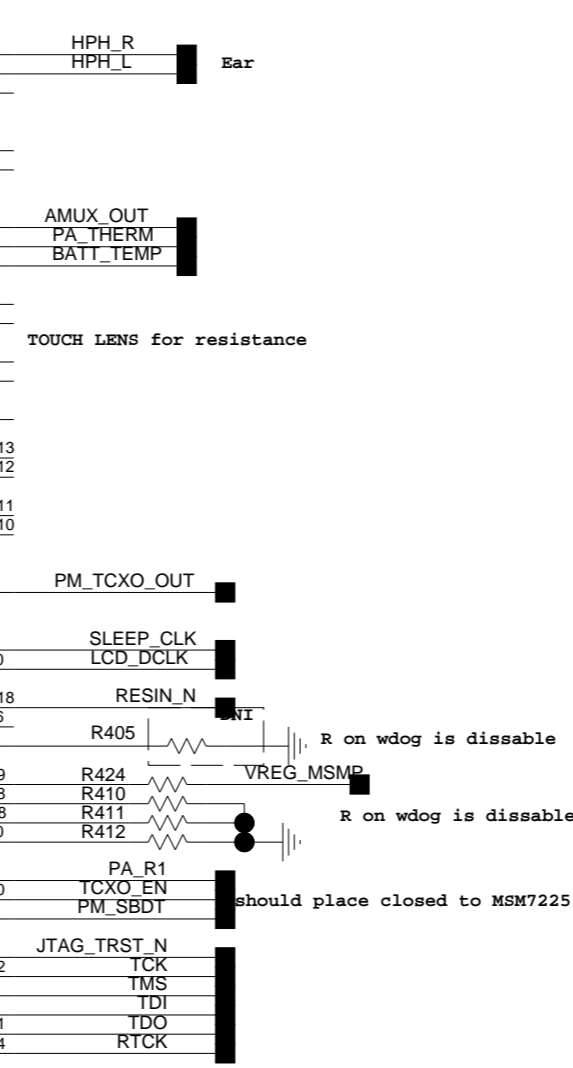
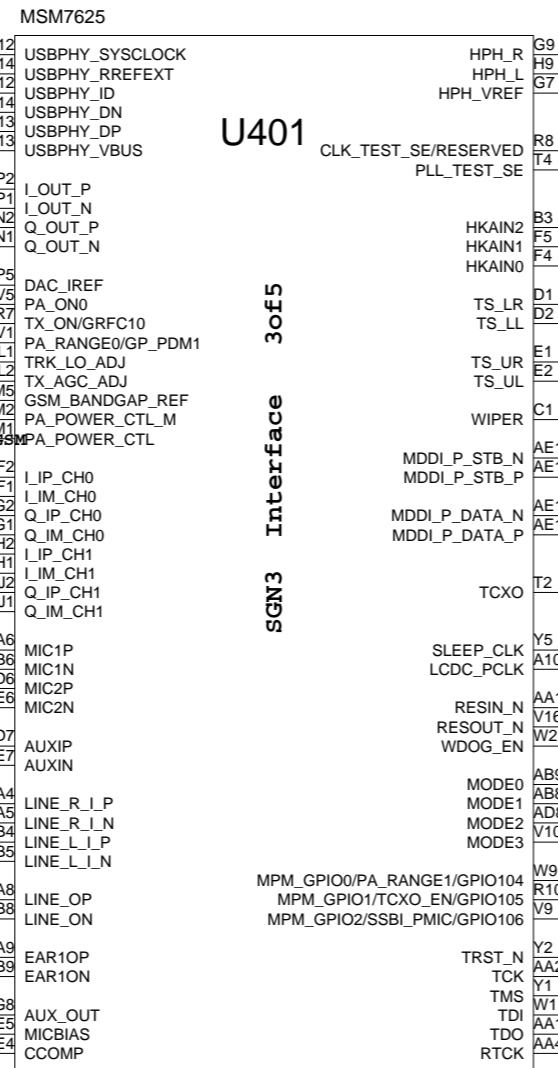
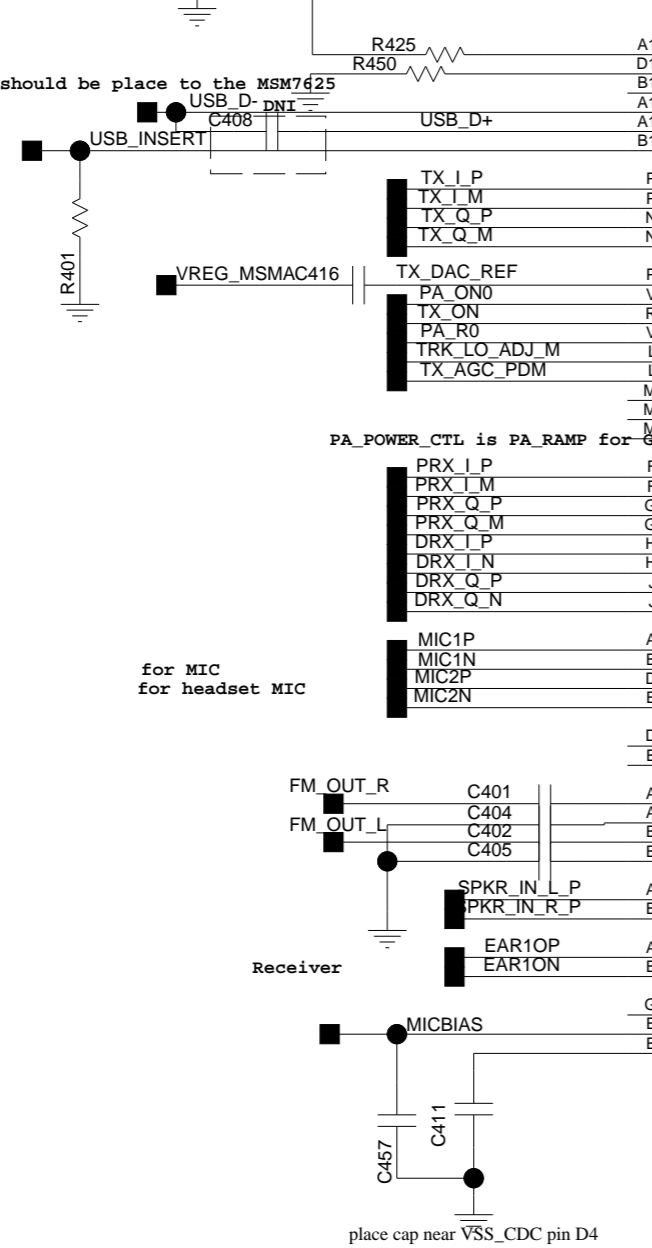

The type and specification of the components refer to the BOM

				NA	2009-04-26
				ECA NO	DATE
DESIGNED	JI JIANGHUI 66114	HC1M860M		00597618	
REVIEWED	XU XUESONG 57251	VER	PART_NUMBER	SHEET 4 OF 34	
			03020VQA	HUAWEI TECH CO.,LTD.	

EST1	Mode
1	Normal
0	Test

5. MSM7625 POWER and GROUND

MSM7625 GROUND

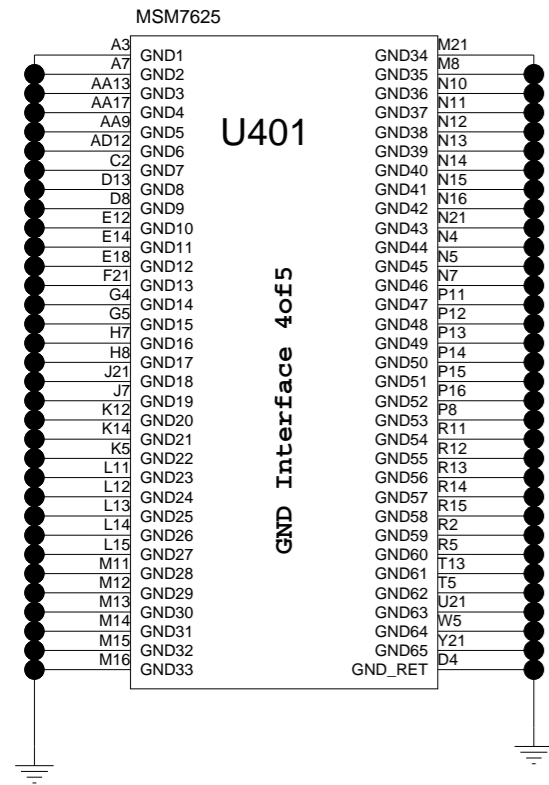

MSM7625 POWER

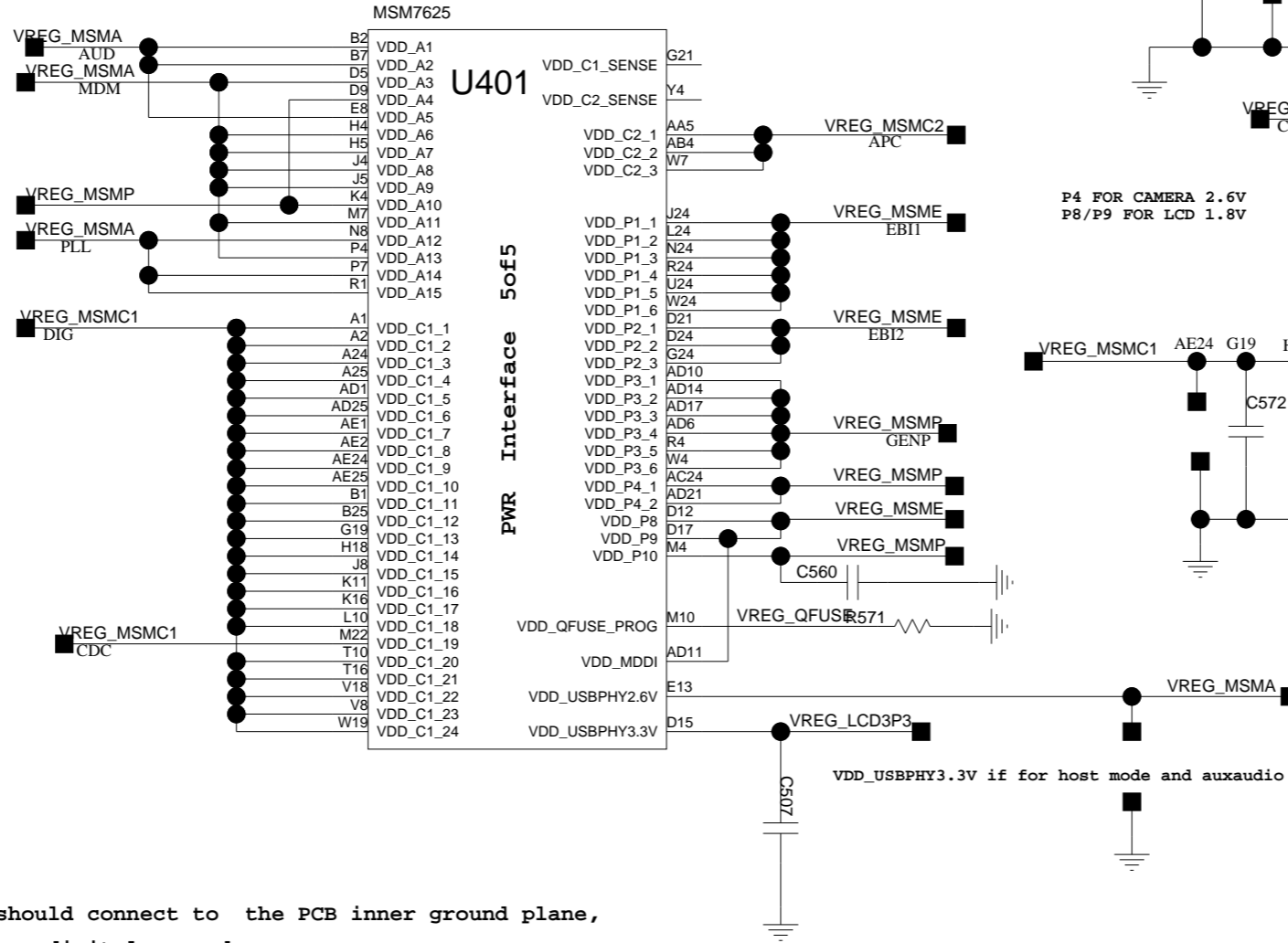

all VREG_MSMA caps should connect to the PCB inner ground plane, NOT to the first layer digital ground

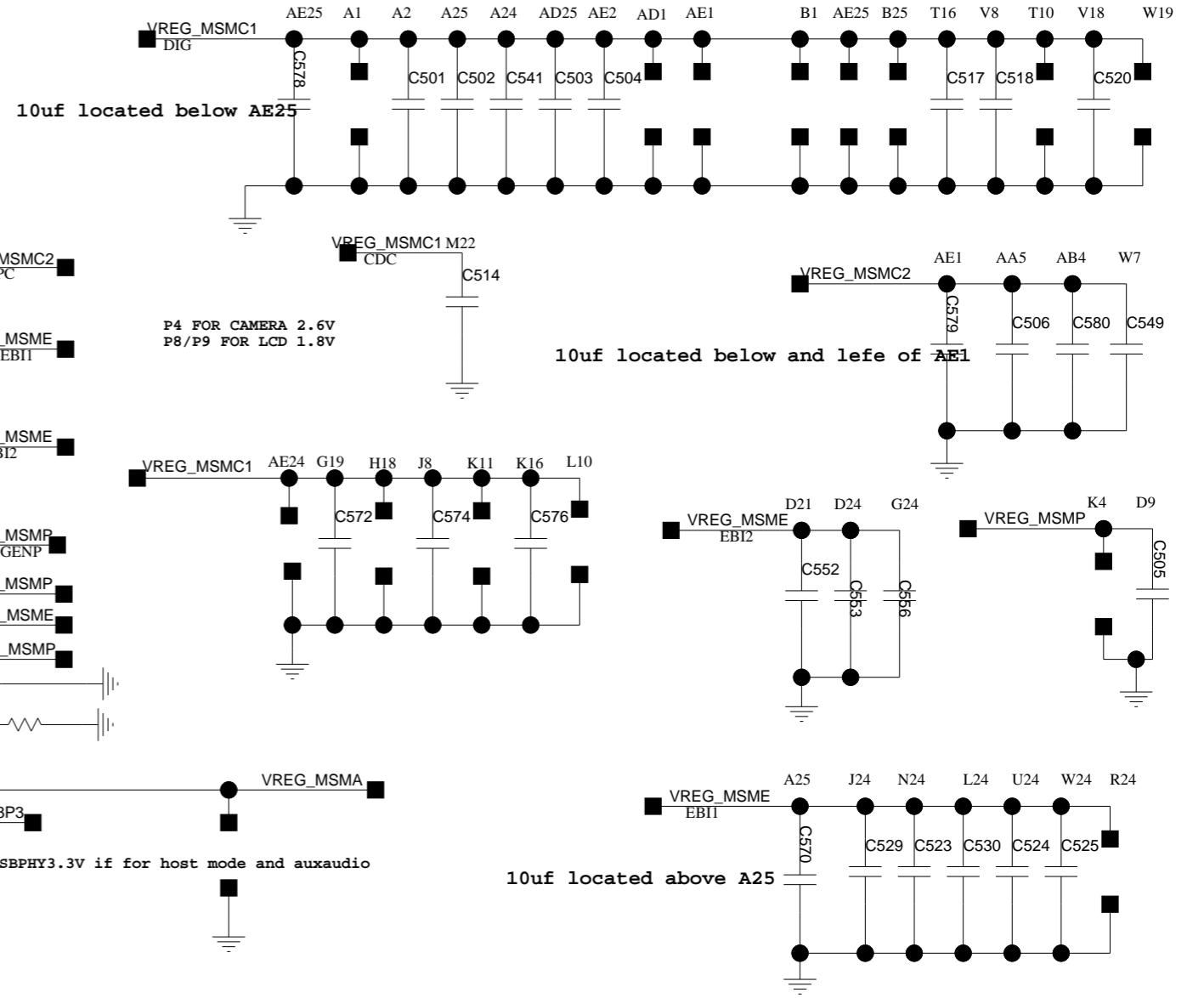
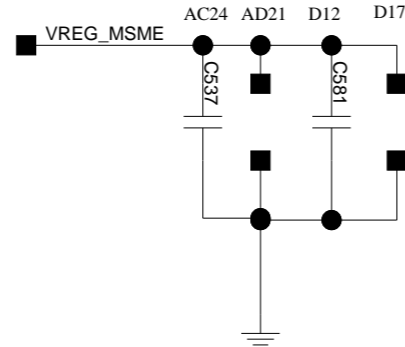
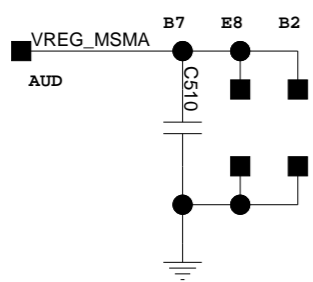
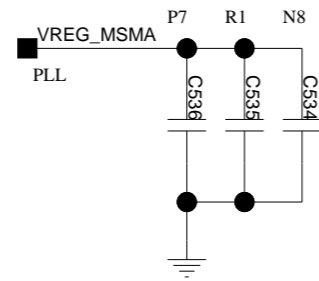
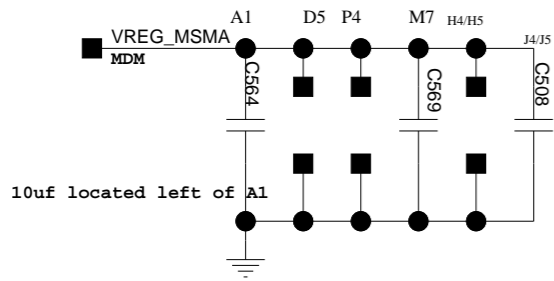

The type and specification of the components refer to the BOM

				NA	2009-04-26
				ECA NO	DATE
DESIGNED	JI JIANGHUI 66114	HC1M860M		00597618	
REVIEWED	XU XUESONG 57251	VER	PART_NUMBER	SHEET 5 OF 34	
			03020VQA	HUAWEI TECH CO.,LTD.	

6. MSM7625 Memory Interface

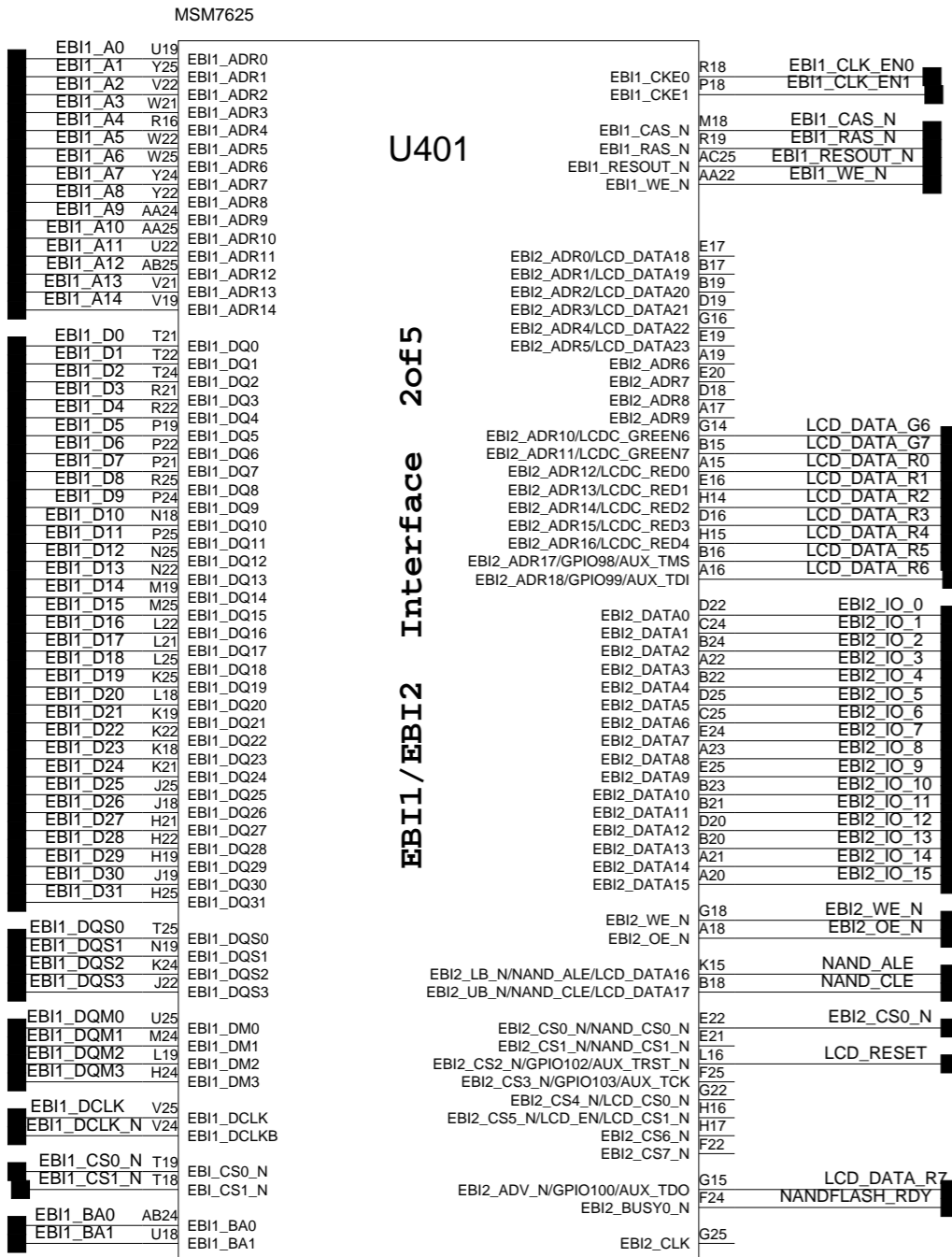

The type and specification of the components refer to the BOM

				NA	2009-04-26
				ECA NO	DATE
DESIGNED	JI JIANGHUI 66114	HC1M860M		00597618	
REVIEWED	XU XUESONG 57251				
		VER	PART_NUMBER	SHEET 6 OF 34	
			03020VQA	HUAWEI TECH CO.,LTD.	

7. Memory

DDR2 SDRAM & NAND FLASH

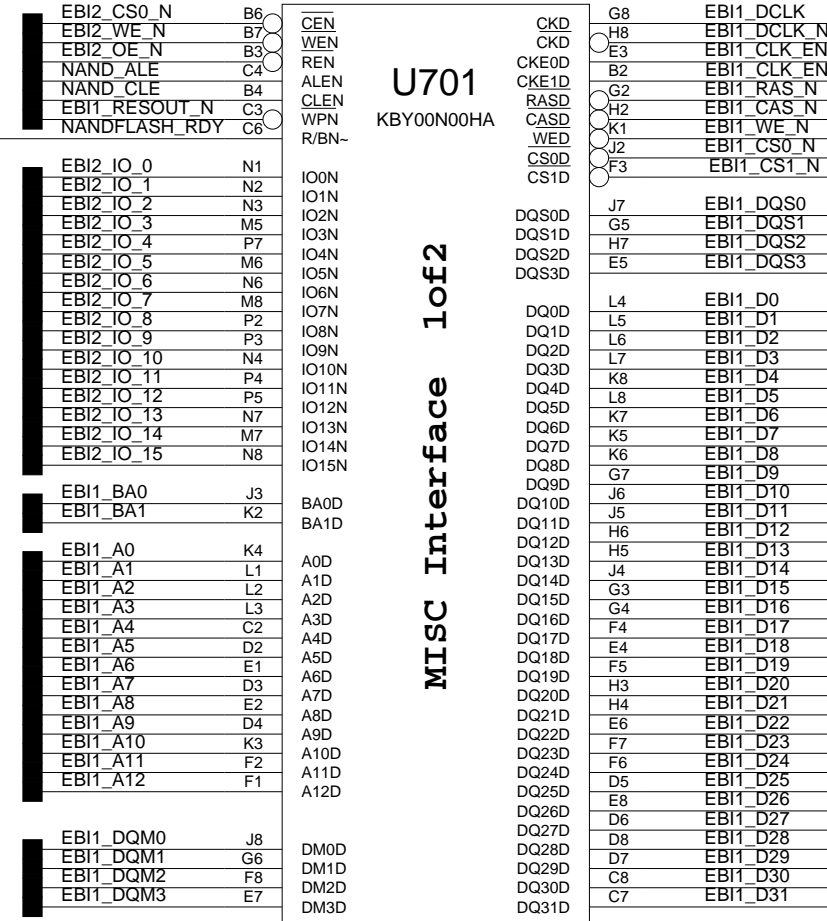
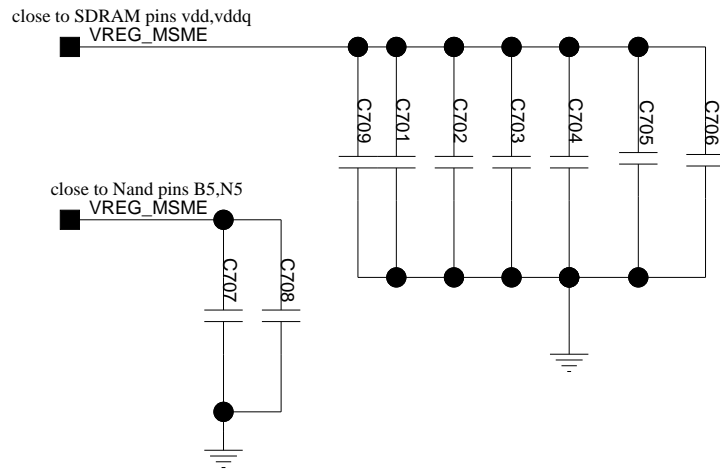
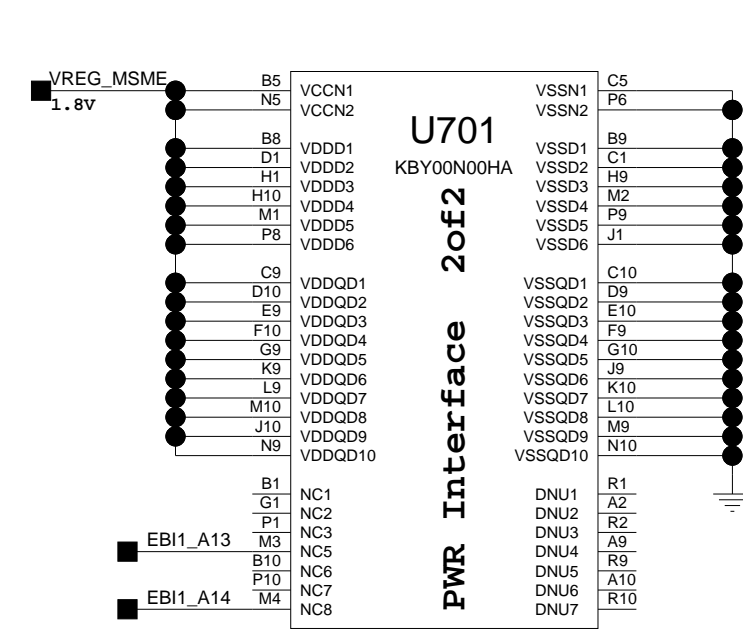

SDRAM DQS singles and EBI1_Dx must be matched length
Trace Length diff between EBI1_DCLK and EBI1_DCLKB less than 100 mil

The type and specification of the components refer to the BOM

				NA	2009-04-26
				ECA NO	DATE
DESIGNED	JI JIANGHUI 66114	HC1M860M		00597618	
REVIEWED	XU XUESONG 57251				
		VER	PART_NUMBER	SHEET 7 OF 34	
			03020VQA	HUAWEI TECH CO.,LTD.	

8. MSM7625 GPIOs and All Peripheral Interface

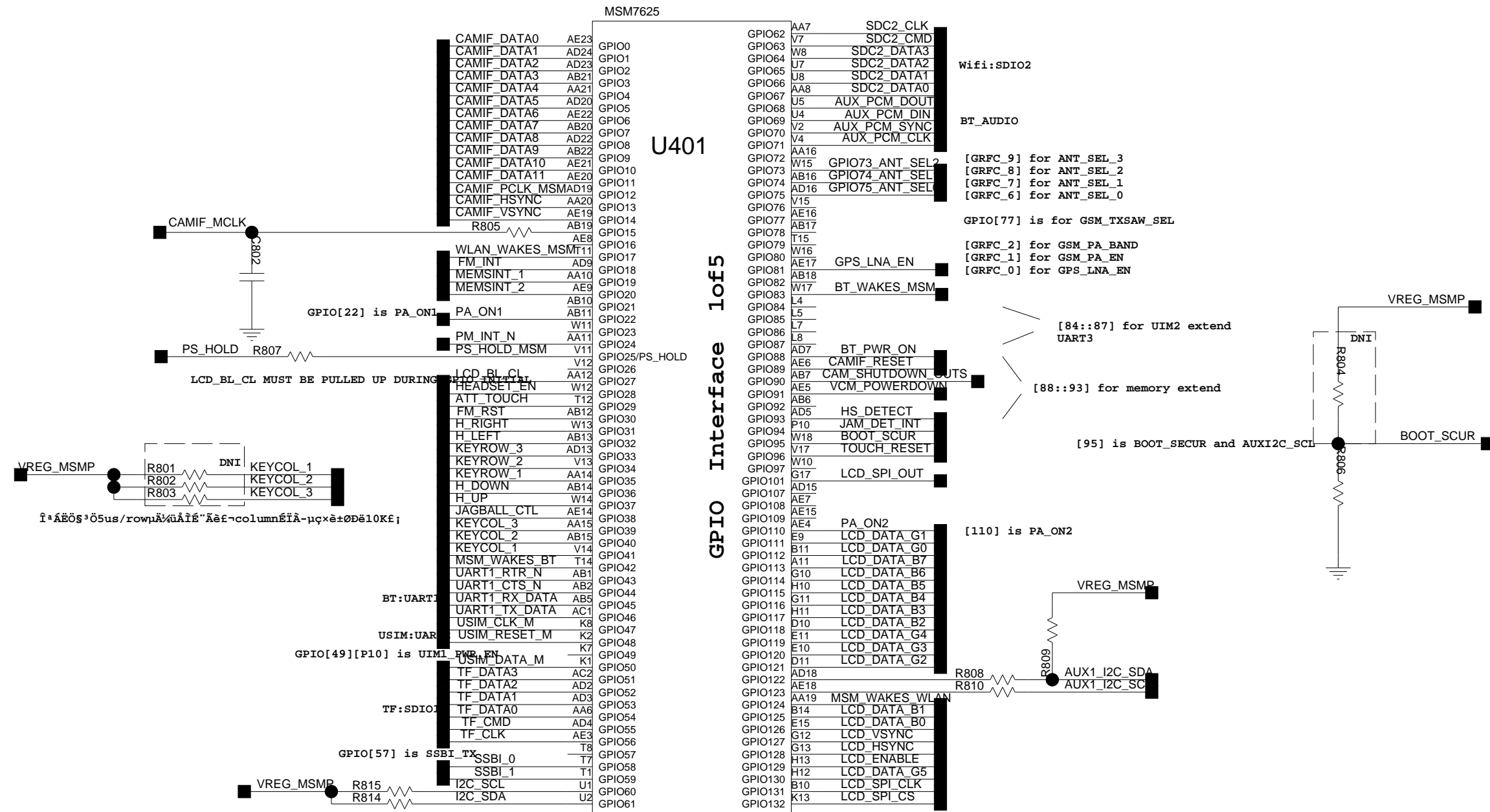

The type and specification of the components refer to the BOM

VER2 NC	VER1 GPIO104	VER0 GPIO35	VER DEFAULT UP
0	0	0	A
0	0	1	B
0	1	0	C

				NA	2009-04-26
				ECA NO	DATE
DESIGNED	JI JIANGHUI 66114	HC1M860M		00597618	
REVIEWED	XU XUESONG 57251	VER	PART_NUMBER	SHEET 8 OF 34	
			03020VQA	HUAWAI TECH CO.,LTD.	

9. LCD interface

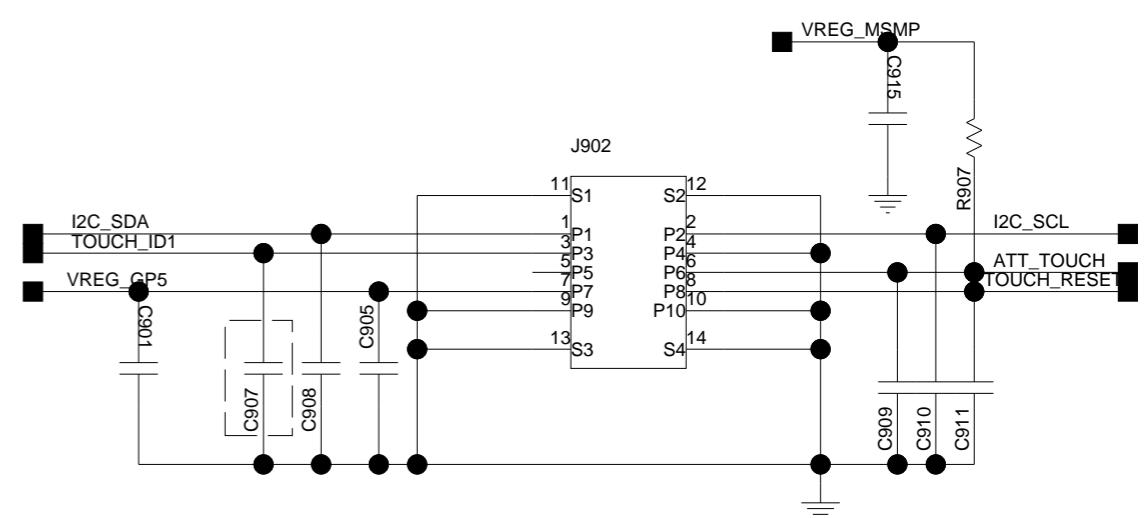
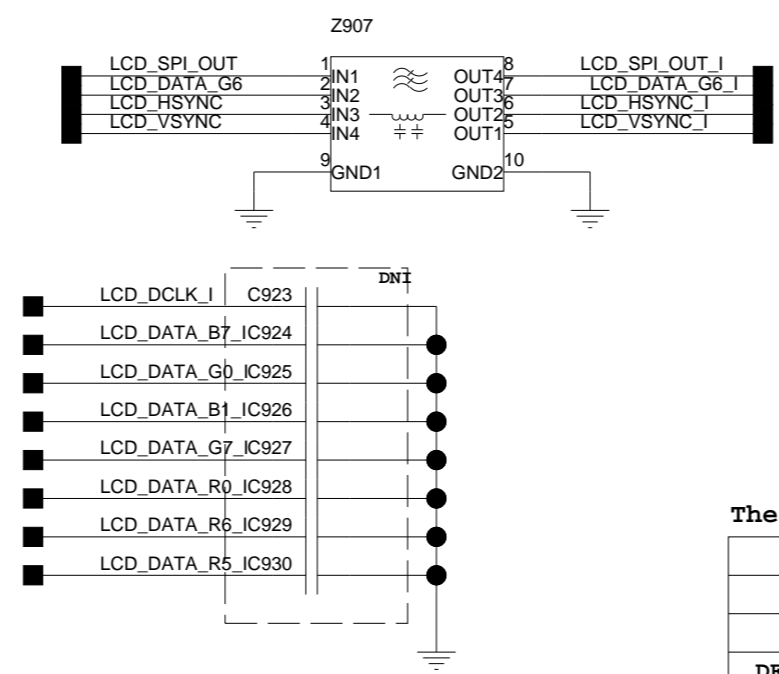
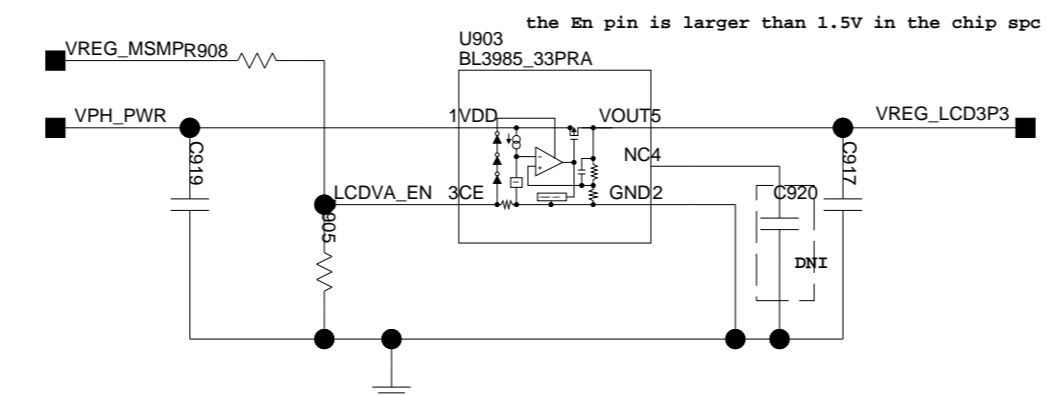
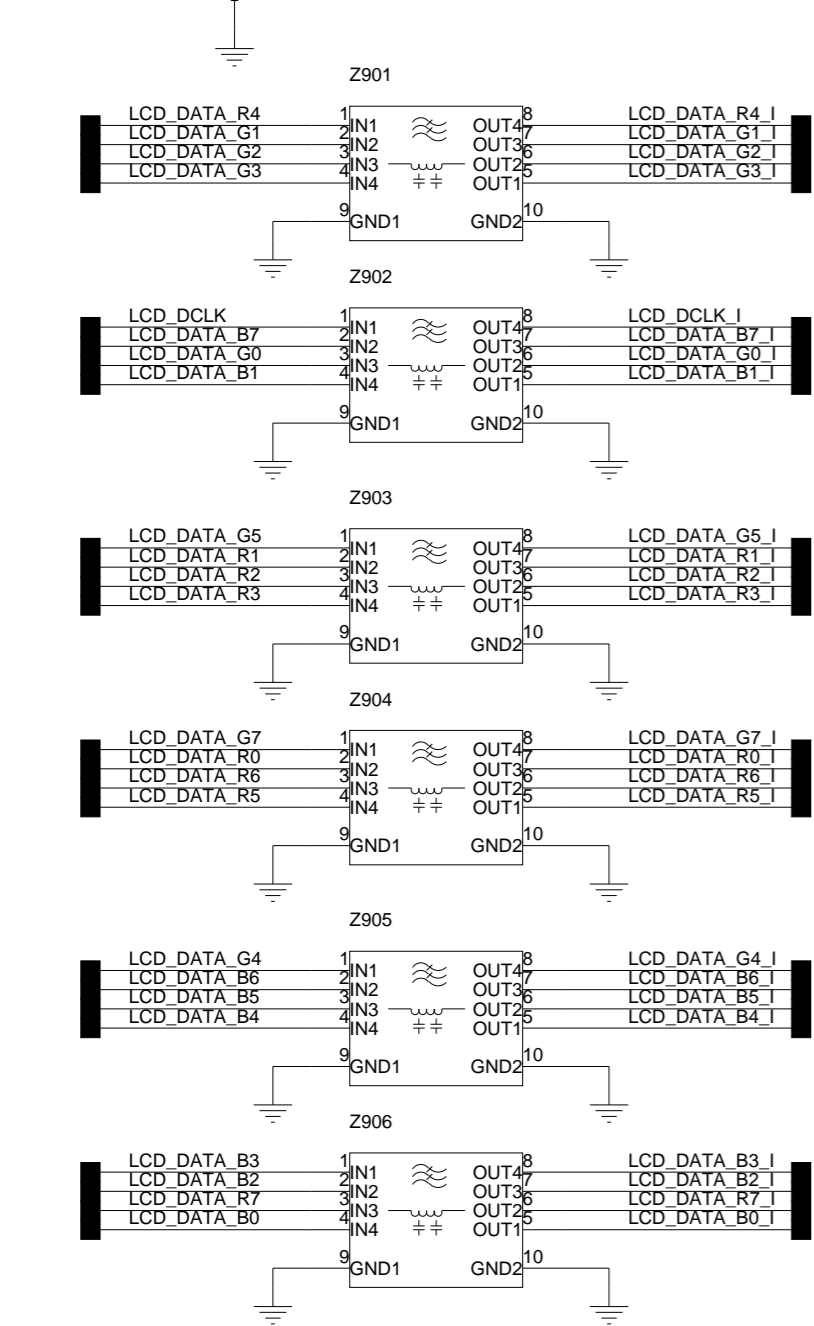
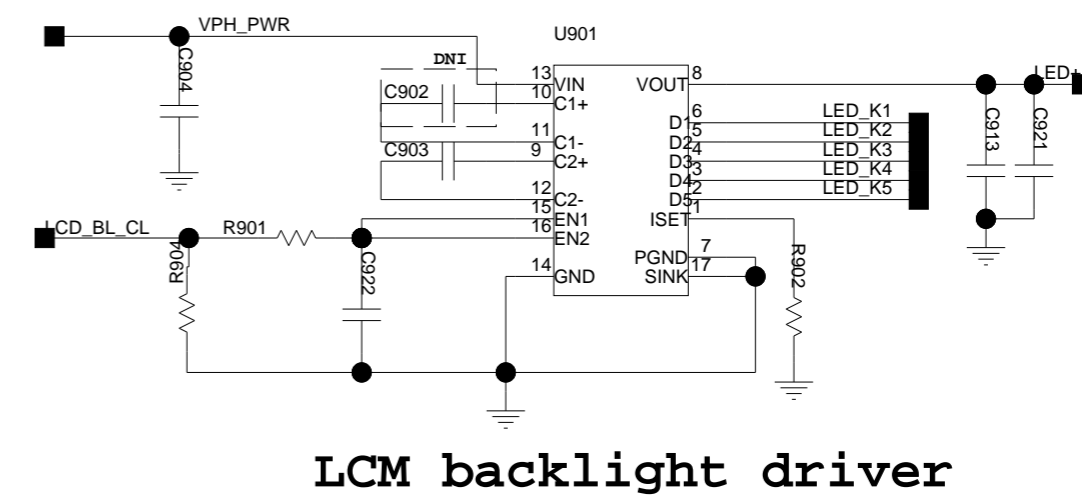
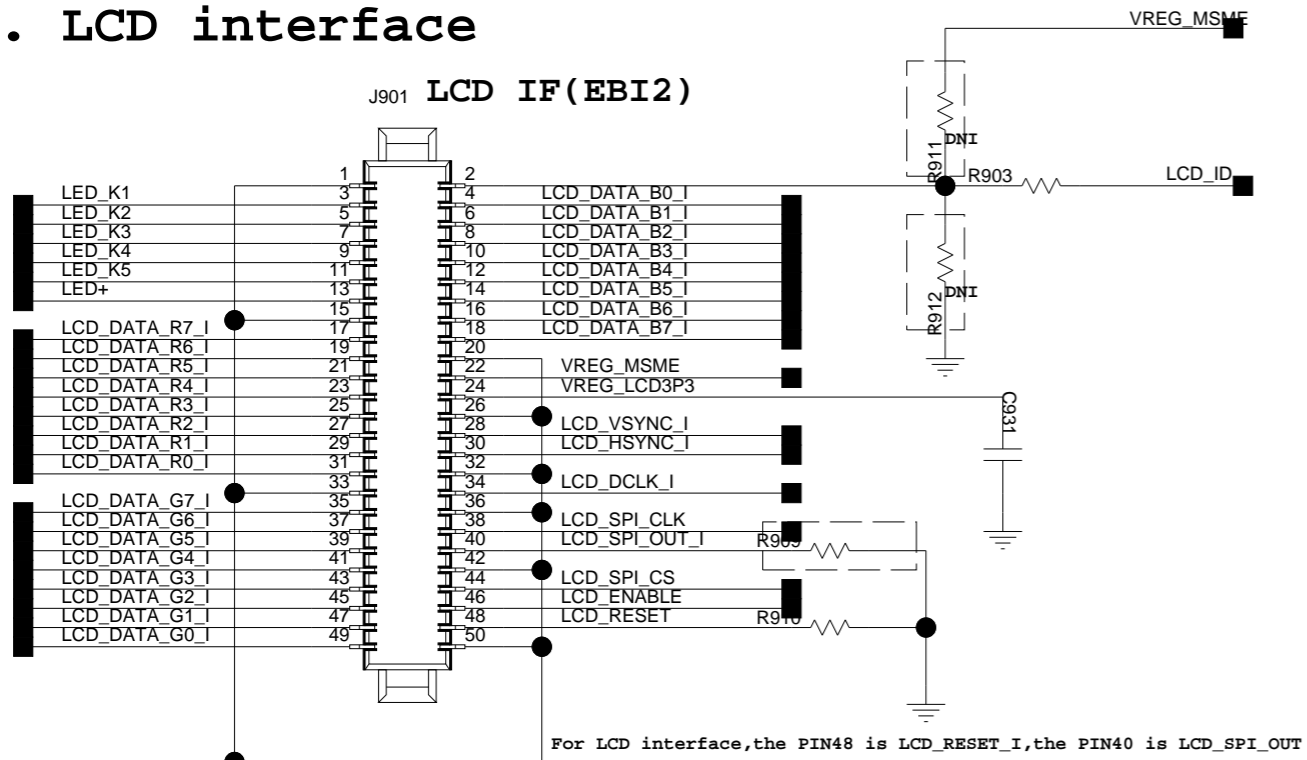

The type and specification of the components refer to the BOM

DESIGNED	JI JIANGHUI 66114	HC1M860M	NA	2009-04-26
REVIEWED	XU XUESONG 57251	03020VQA	ECA NO	DATE
		VER	PART_NUMBER	SHEET 9 OF 34
				HUAWEI TECH CO.,LTD.

10 Camera IF and Compass

500W CAMERA IF define

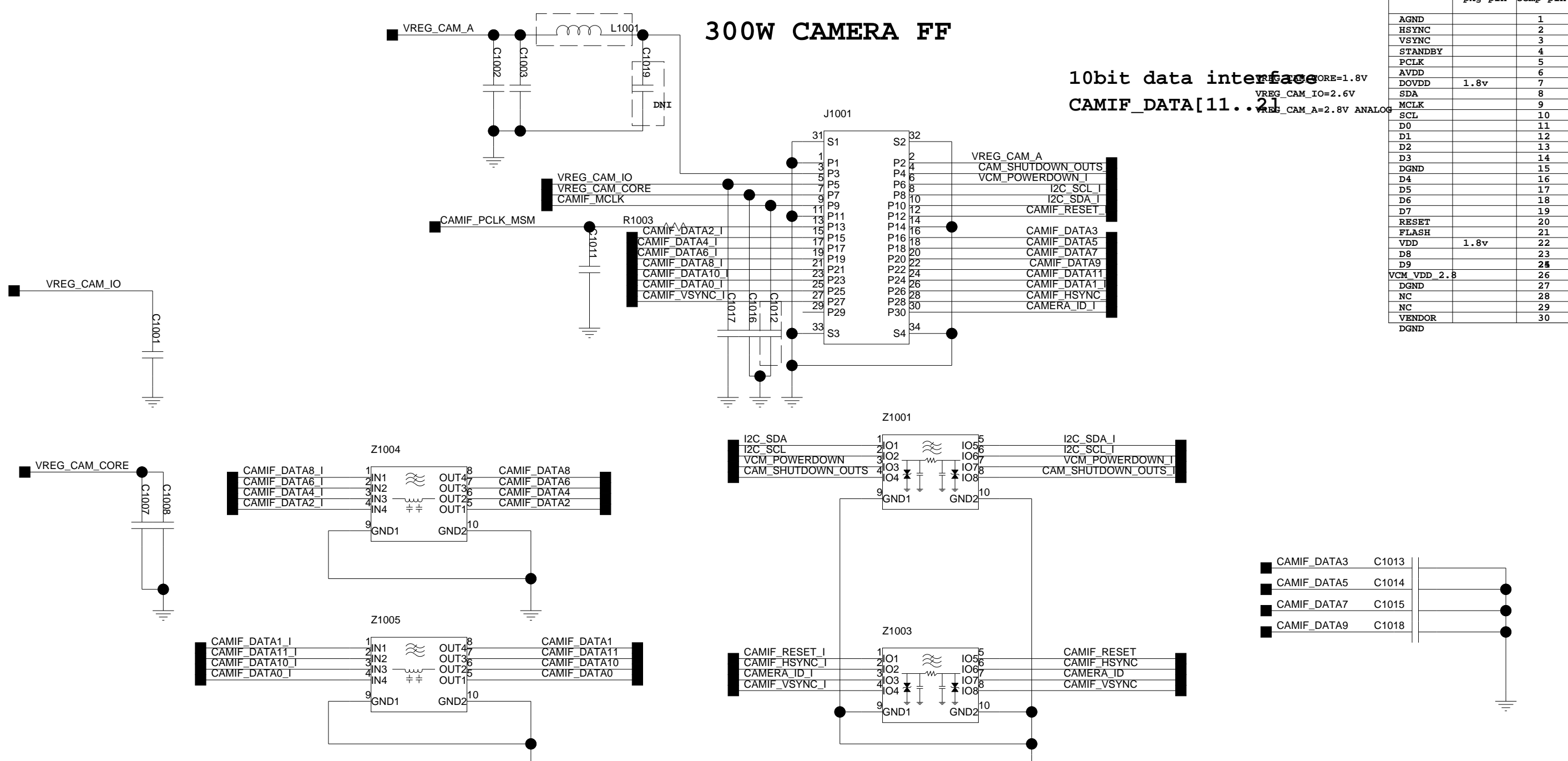

notice: For OV9655, the 14240099's package & symbol are default.
For ST, the 14240099's package is CMC24-1010,
the symbol is jack_plcc32_b.1 in document 00360049

The type and specification of the components refer to the BOM

				NA	2009-04-26
				ECA NO	DATE
DESIGNED	JI JIANGHUI 66114	HC1M860M		00597618	
REVIEWED	XU XUESONG 57251	VER	PART_NUMBER	SHEET 10 OF 34	
			03020VQA	HUAWEI TECH CO.,LTD.	

11.Acoustic Part Include MIC/Vibrator/Speaker

CAD Note: Place right components close to MSM

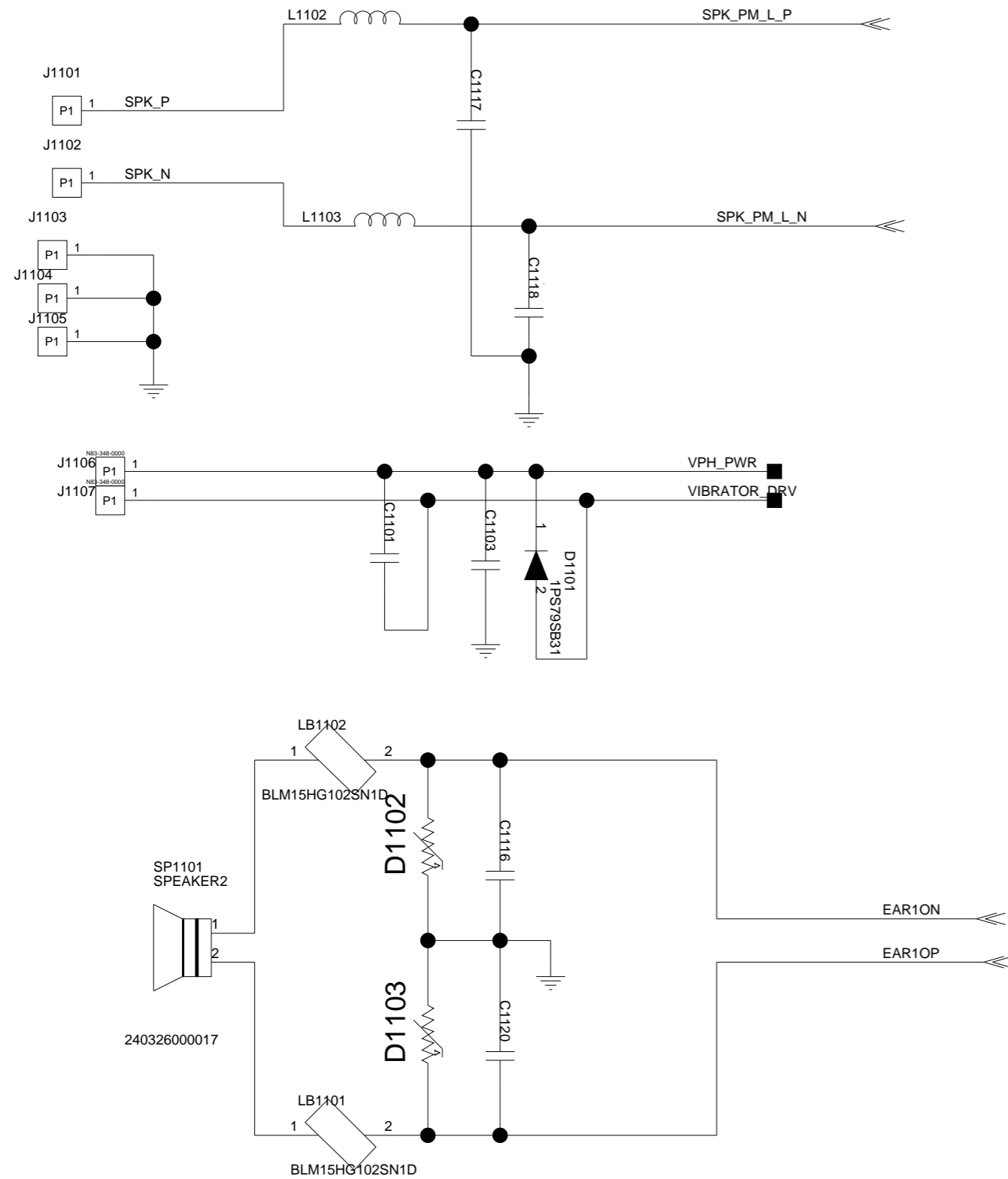

Handset MIC

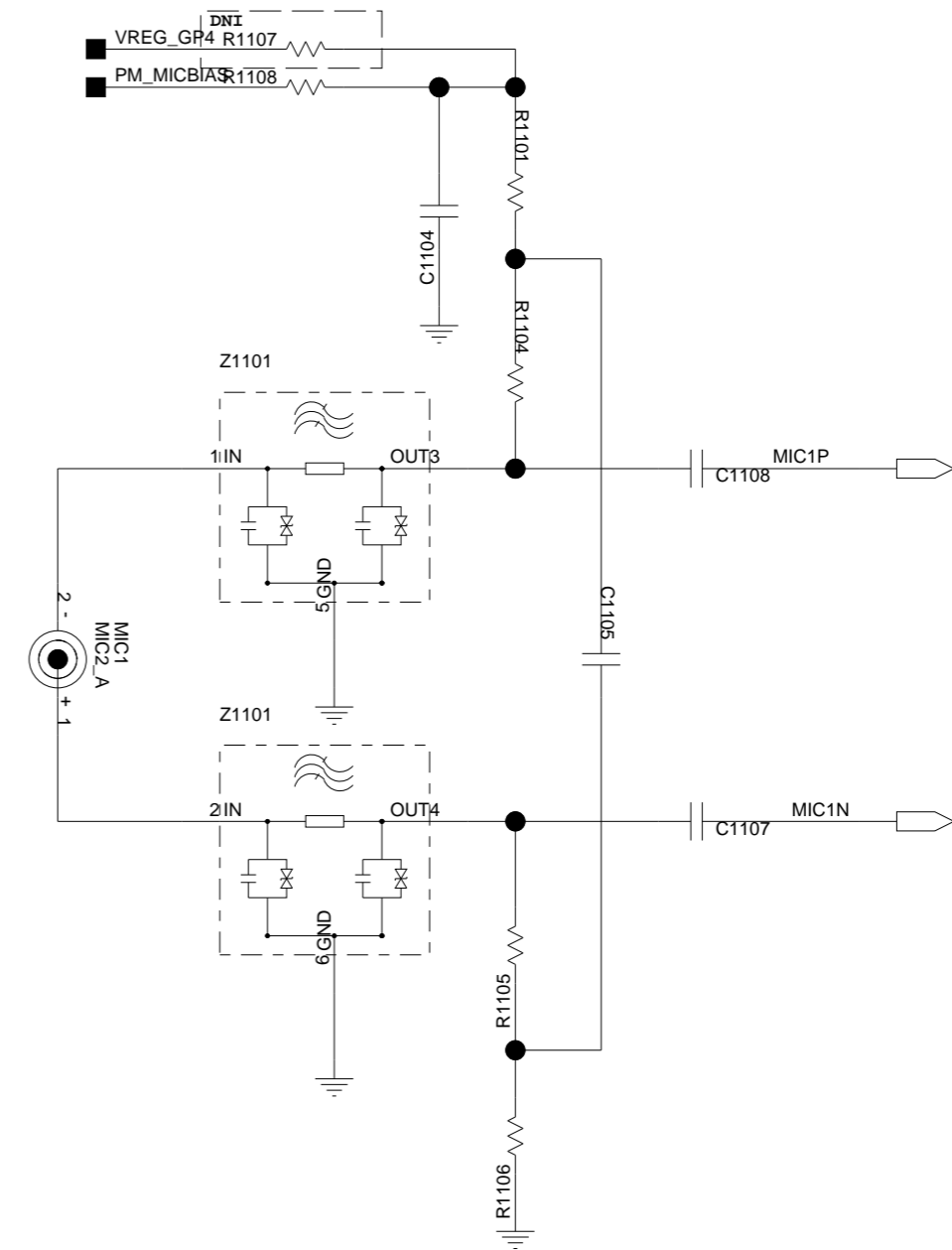

the circuit here do not change

try to use this mic's code to reduce the price

				NA	2009-04-26
				ECA NO	DATE
DESIGNED	JI JIANGHUI 66114	HC1M860M		00597618	
REVIEWED	XU XUESONG 57251	VER	PART_NUMBER	SHEET 11 OF 34	
			03020VQA	HUAWEI TECH CO.,LTD.	

12. SIM/TF Card

T-FLASH CARD

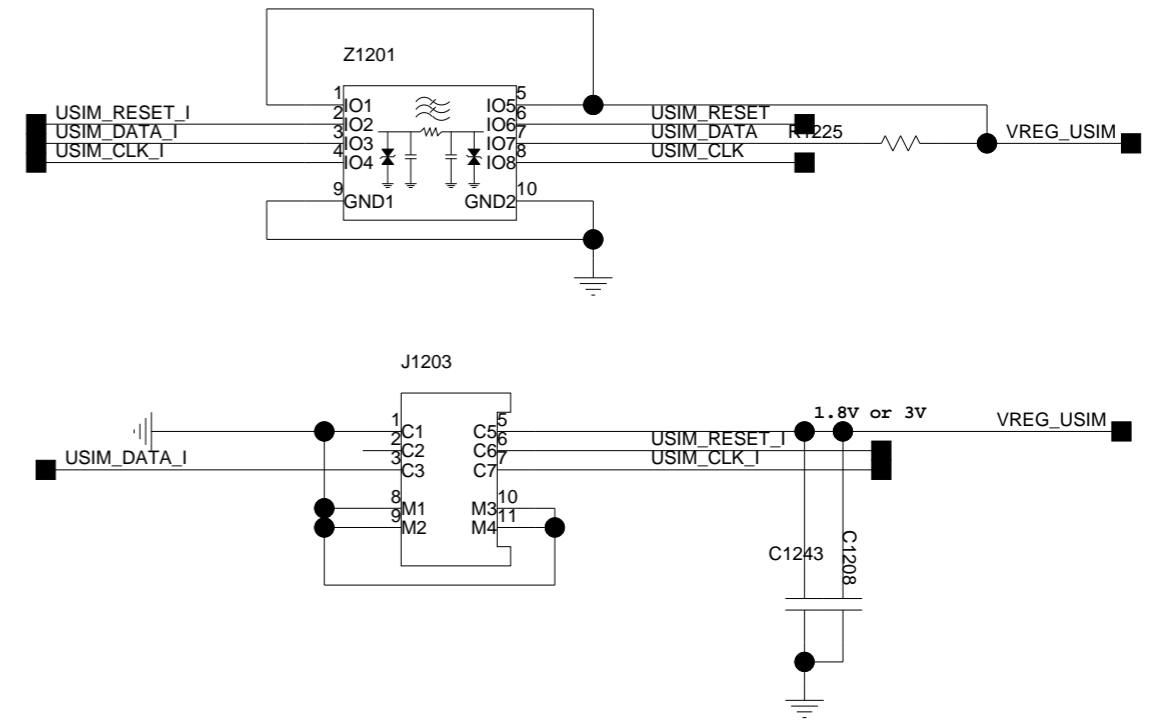
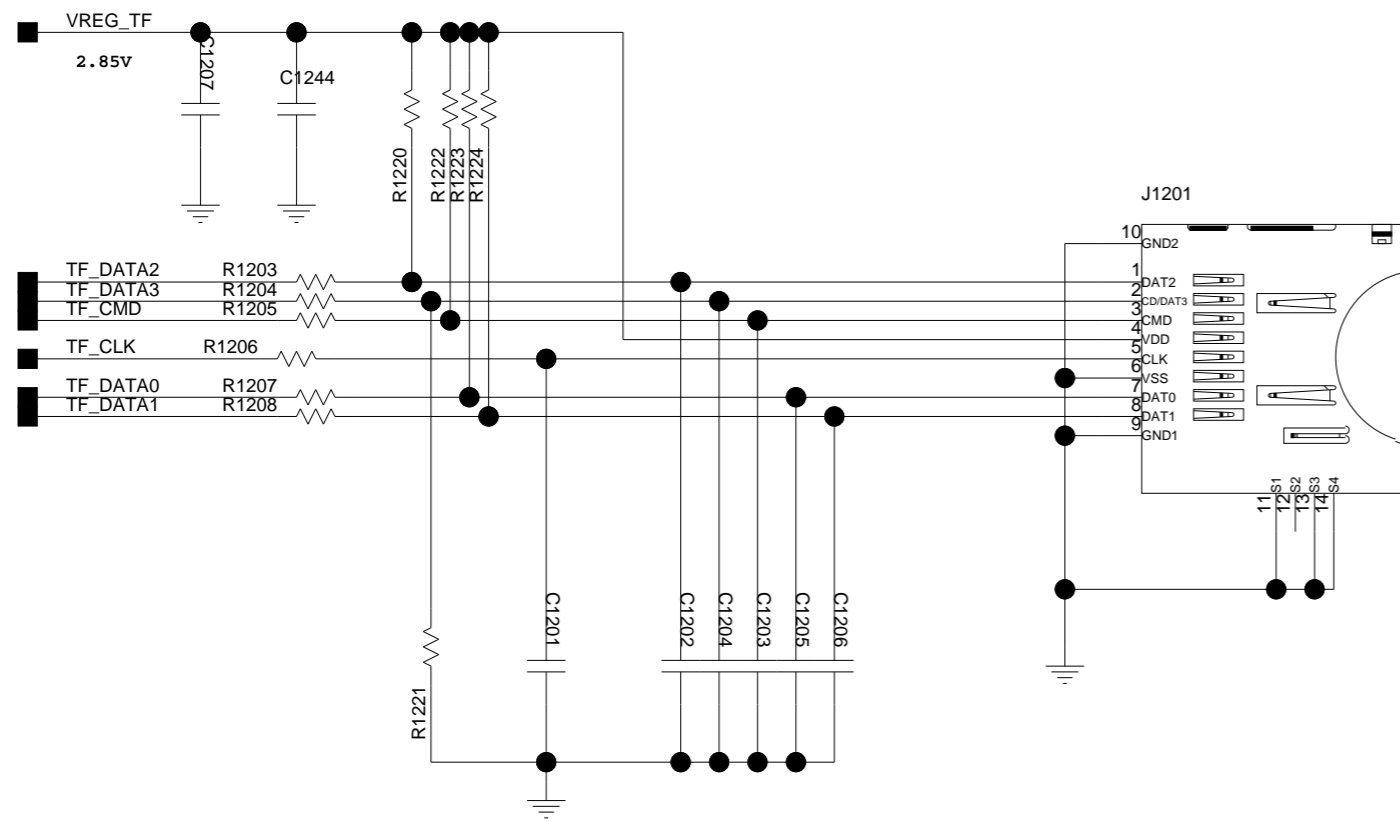

The type and specification of the components refer to the BOM

				NA	2009-04-26
				ECA NO	DATE
DESIGNED	JI JIANGHUI 66114	HC1M860M		00597618	
REVIEWED	XU XUESONG 57251	VER	PART_NUMBER	SHEET 12 OF 34	
			03020VQA	HUAWEI TECH CO.,LTD.	

13. Jog-ball and Array of Keypad

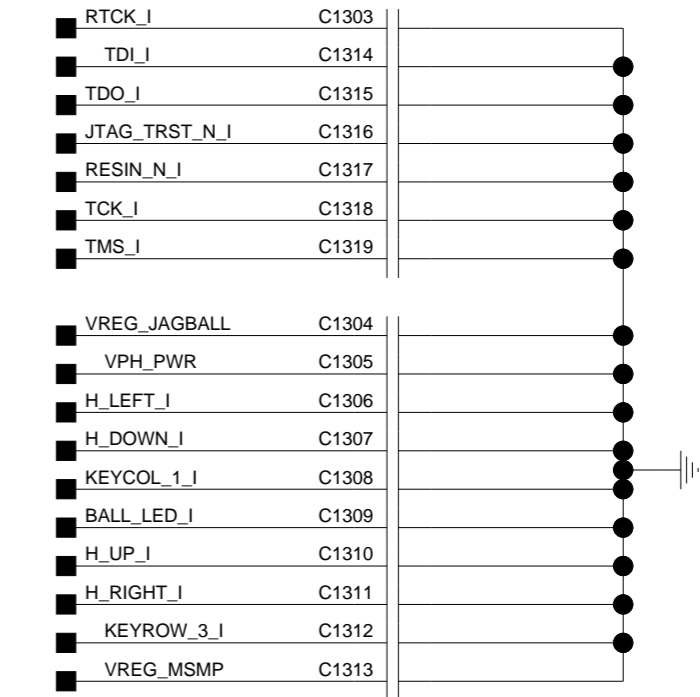
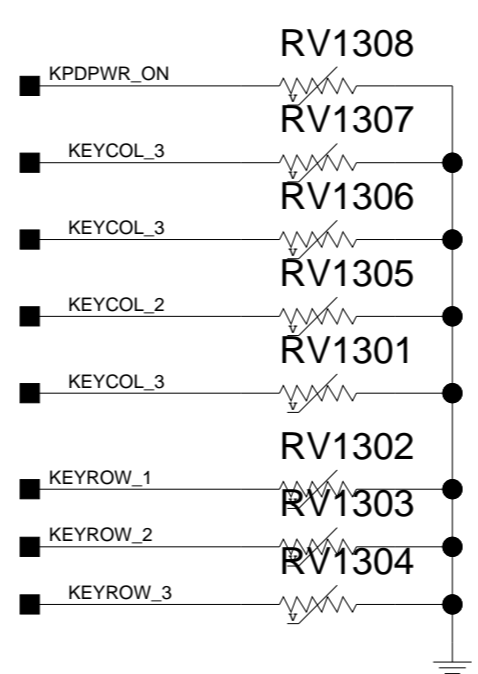
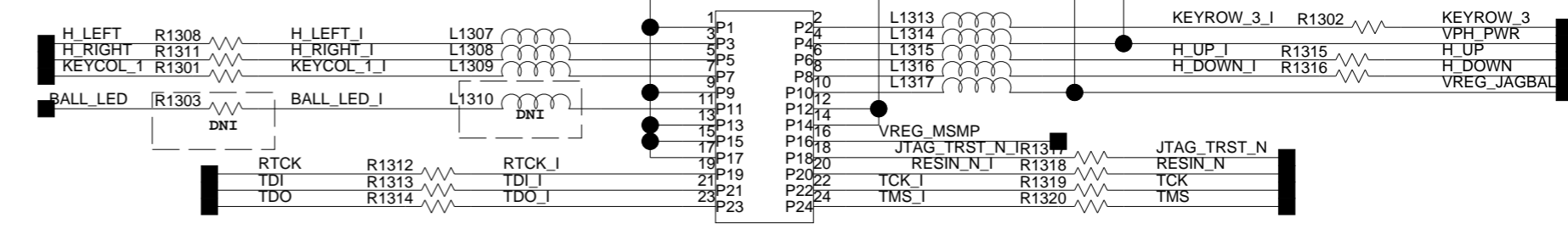
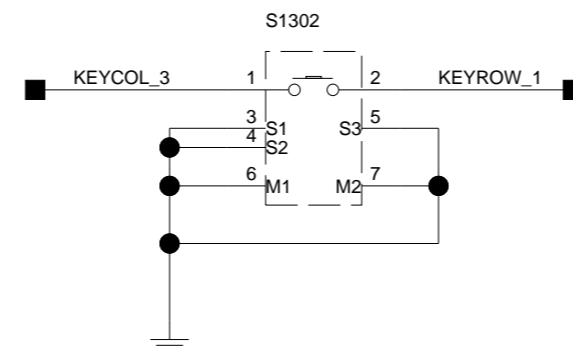
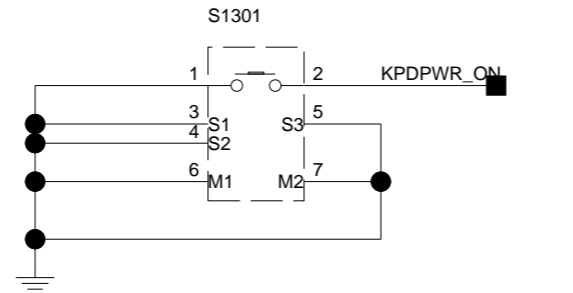
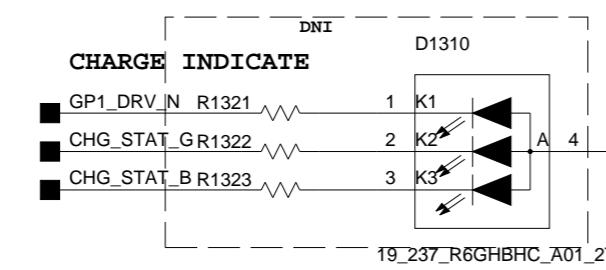
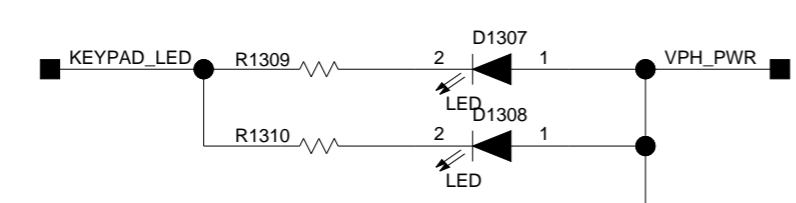
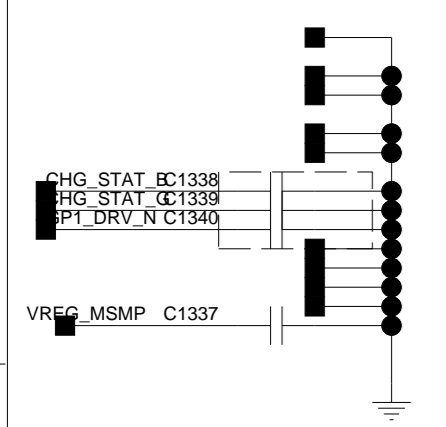
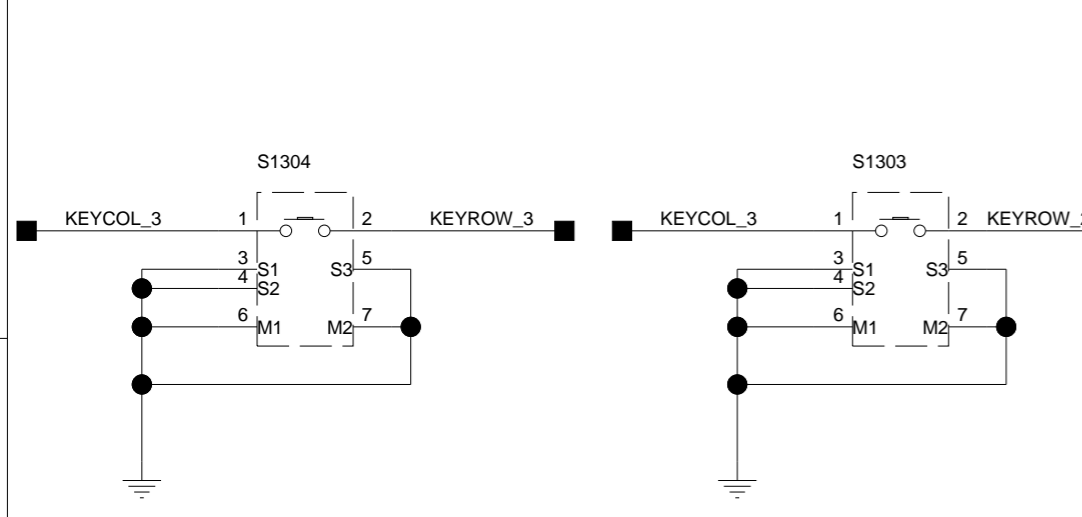
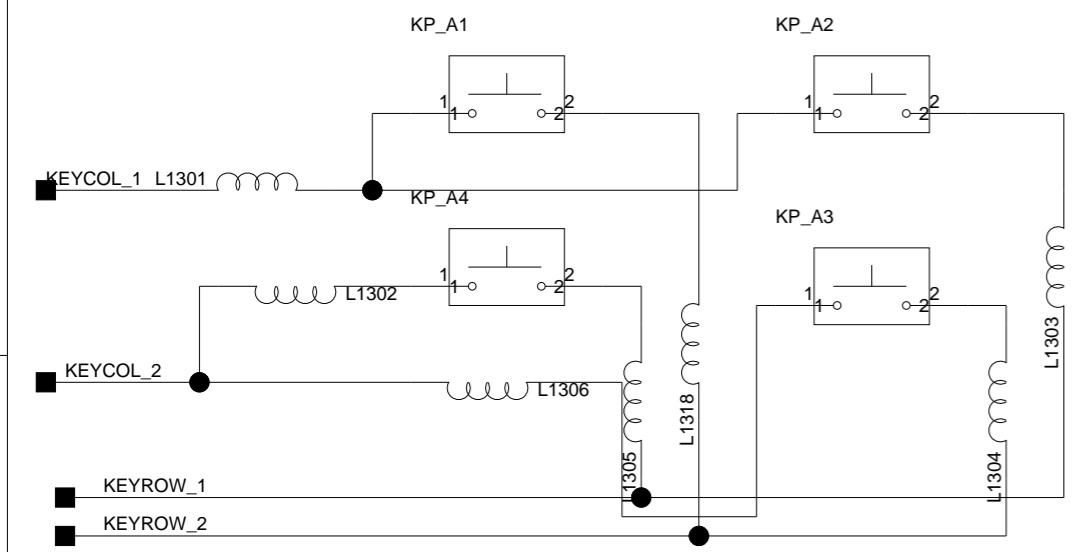

The type and specification of the components refer to the BOM

				NA	2009-04-26
				ECA NO	DATE
DESIGNED	JI JIANGHUI 66114	HC1M860M		00597618	
REVIEWED	XU XUESONG 57251	VER	PART_NUMBER	SHEET 13 OF 34	
			03020VQA	HUAWEI TECH CO.,LTD.	

14.USB,Headset circuit

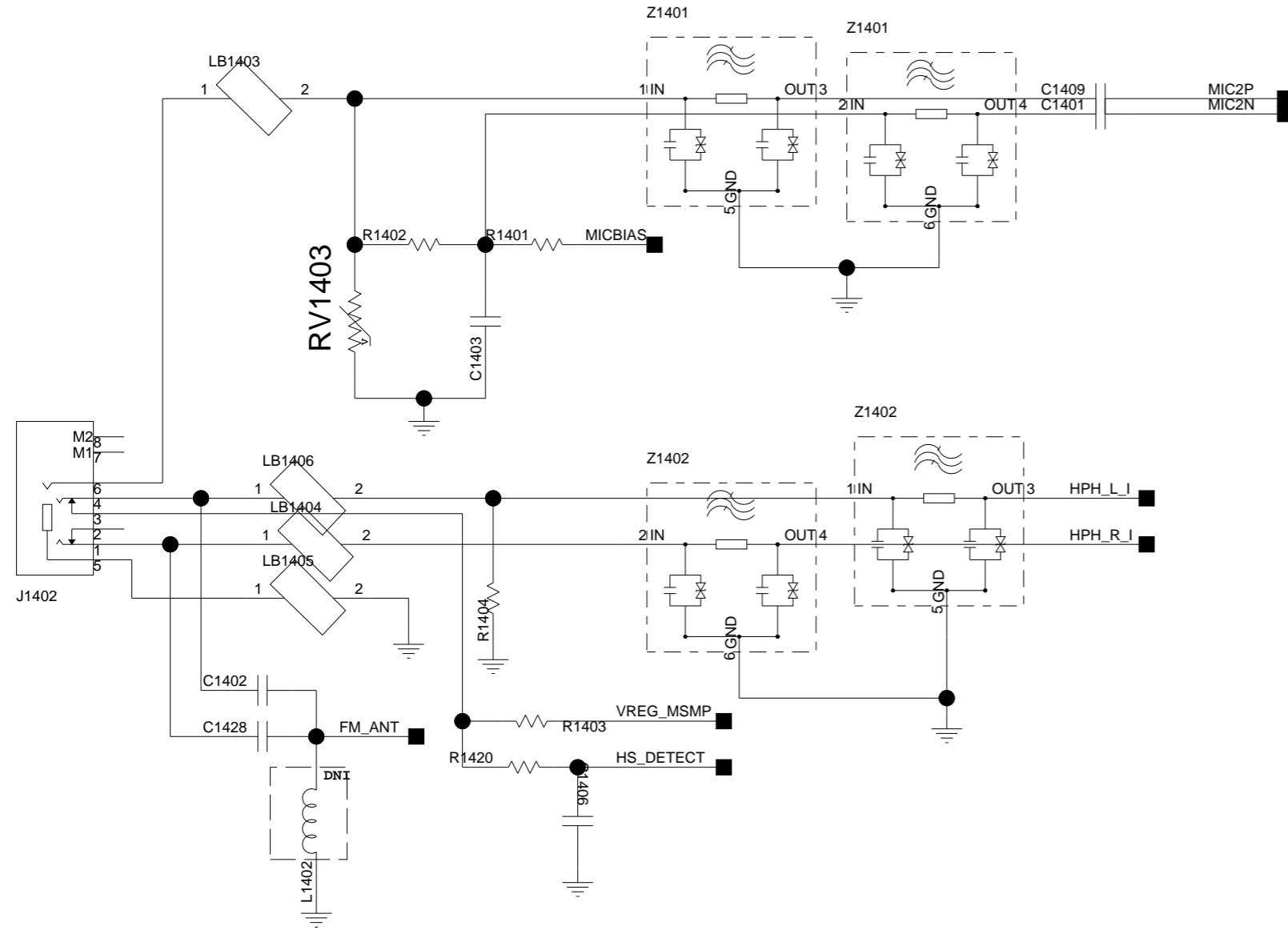

MicroUSB

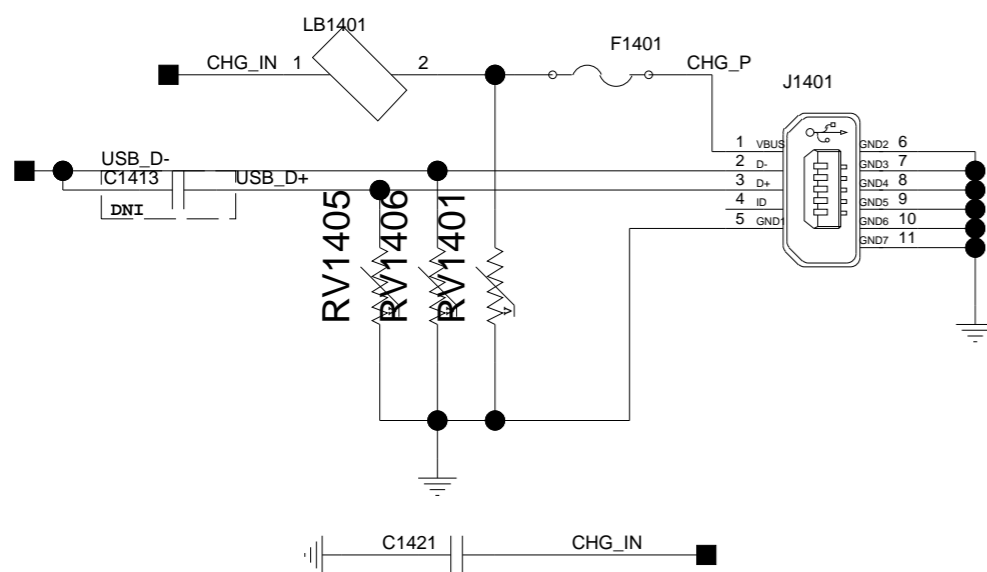

Stereo Headphone Amplifier

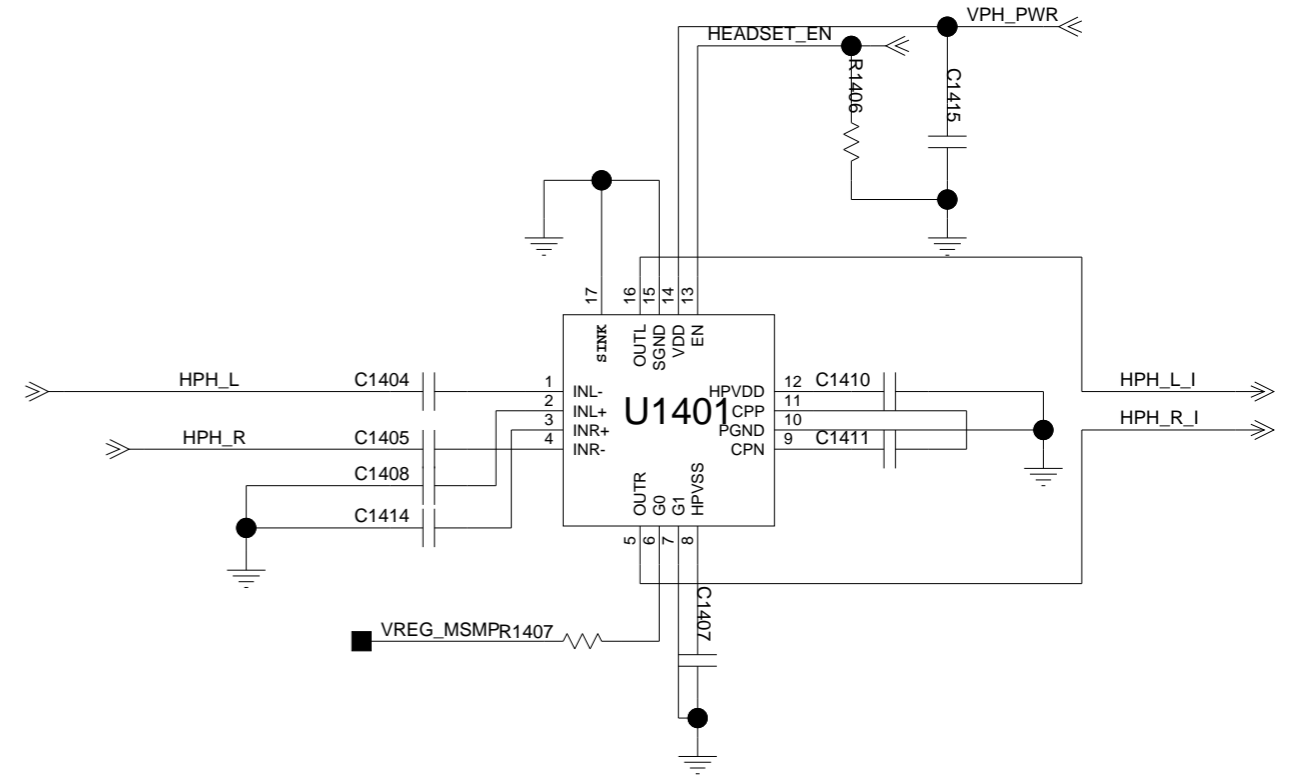

Connect SINK to the GND plane with a via array under the expo

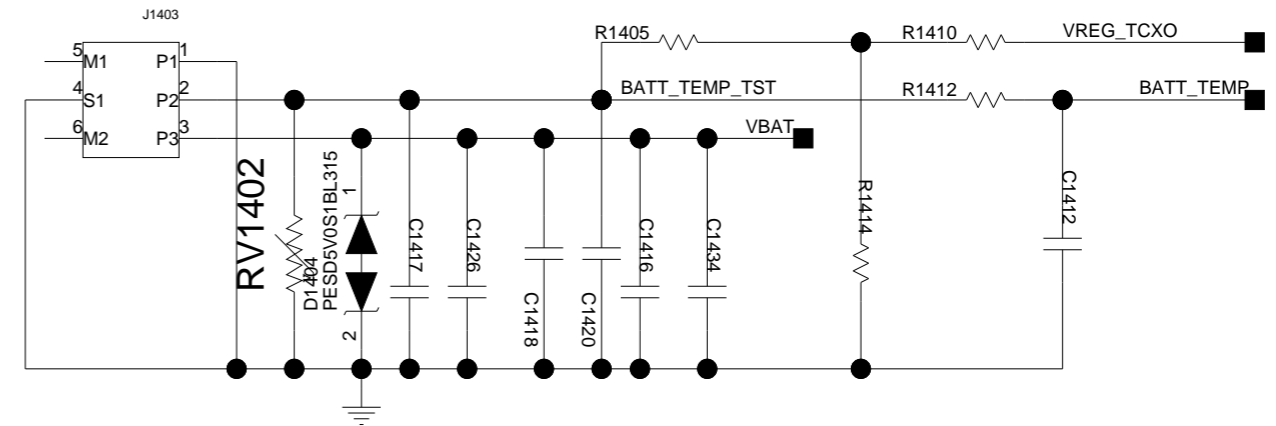

The type and specification of the components refer to the BOM

				NA	2009-04-26
				ECA NO	DATE
DESIGNED	JI JIANGHUI 66114	HC1M860M		00597618	
REVIEWED	XU XUESONG 57251	VER	PART_NUMBER	SHEET 14 OF 34	
			03020VQA	HUAWEI TECH CO.,LTD.	

15. Test Points & Shield Covers

Place test points outside of shield covers.

Place Test Points Outside of Shield!

Figure 1: Test points for SLEEP_CLK and PS_HOLD.

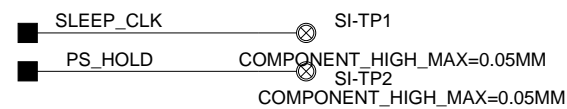

Figure 2: Test points for various signals including VBAT, BATT_TEMP_TST, and KPDPWR_ON.

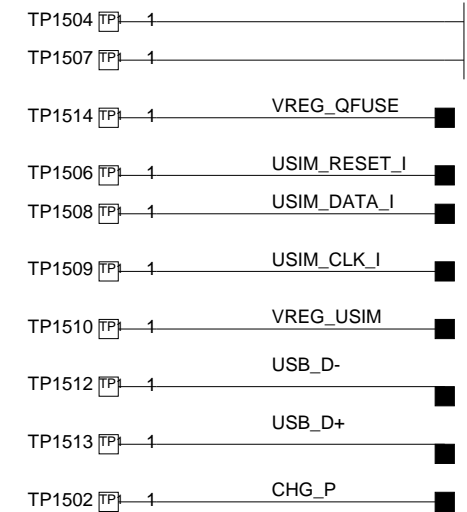
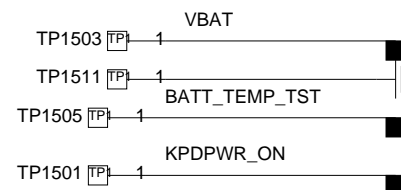
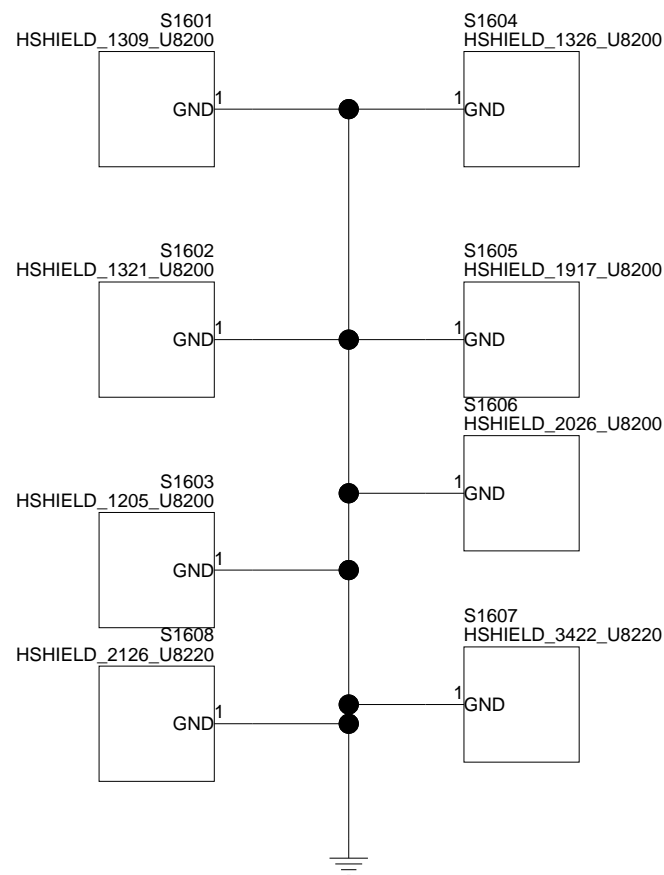

Figure 3: Test points for DataIO and other signals.

Figure 4: Test points for GND and USIM signals.



The type and specification of the components refer to the BOM

				NA	2009-04-26
				ECA NO	DATE
DESIGNED	JI JIANGHUI 66114	HC1M860M		00597618	
REVIEWED	XU XUESONG 57251	VER	PART_NUMBER	SHEET 15 OF 34	
			03020VQA	HUAWEI TECH CO.,LTD.	

16.ACCELERATOR_COMPASS & FM

Accelerometer&Compass

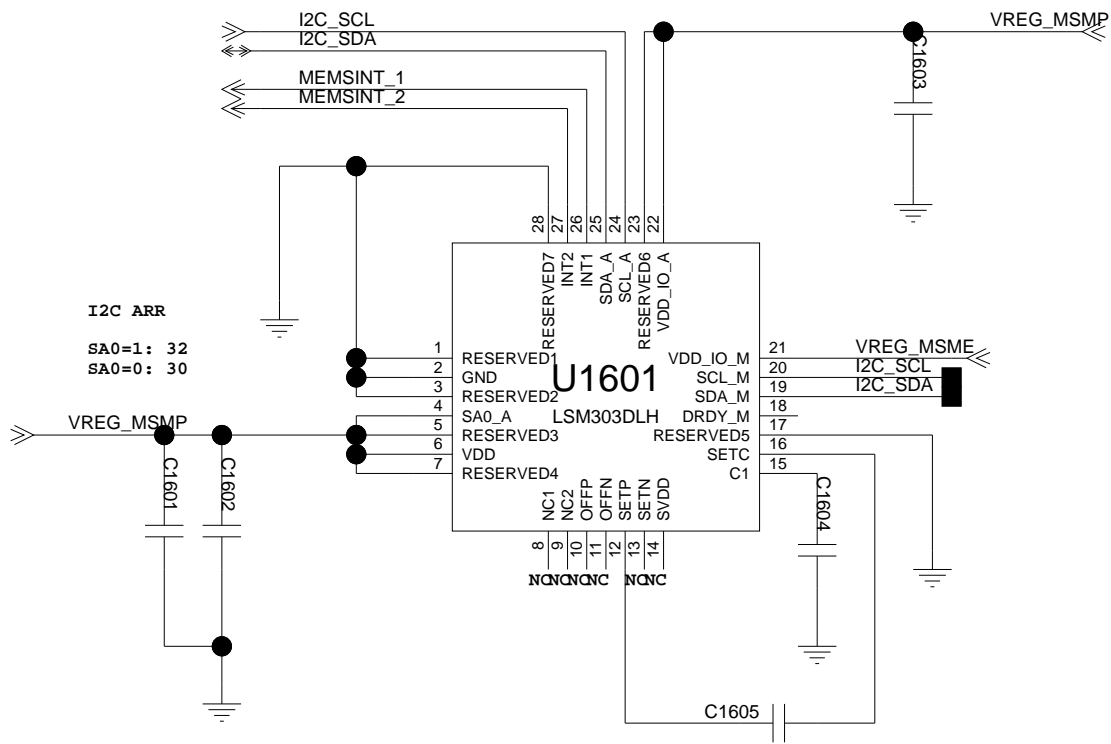

FM

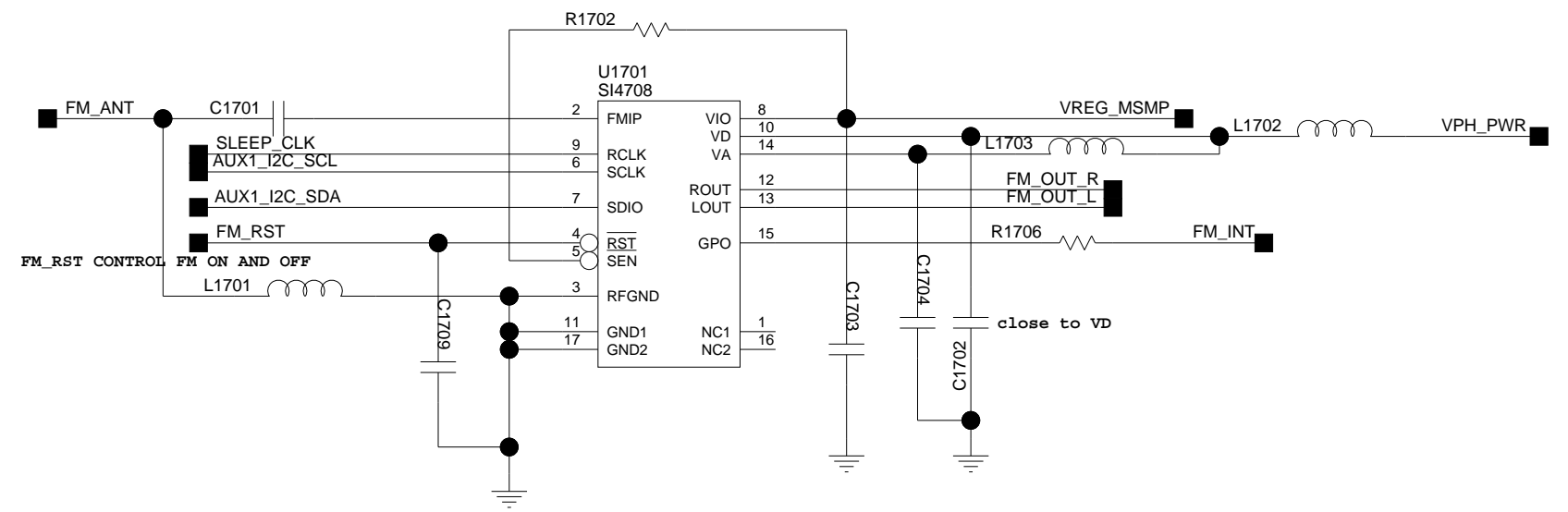

The type and specification of the components refer to the BOM

				NA	2009-04-26
				ECA NO	DATE
DESIGNED	JI JIANGHUI 66114	HC1M860M		00597618	
REVIEWED	XU XUESONG 57251	VER	PART_NUMBER	SHEET 16 OF 34	
			03020VQA	HUAWAI TECH CO.,LTD.	

17.GPIO Mapping 1

GPIO0	CAMIF_DATA0
GPIO1	CAMIF_DATA1
GPIO2	CAMIF_DATA2
GPIO3	CAMIF_DATA3
GPIO4	CAMIF_DATA4
GPIO5	CAMIF_DATA5
GPIO6	CAMIF_DATA6
GPIO7	CAMIF_DATA7
GPIO8	CAMIF_DATA8
GPIO9	CAMIF_DATA9
GPIO10	CAMIF_DATA10
GPIO11	CAMIF_DATA11
GPIO12	CAMIF_PCLK_MSM
GPIO13	CAMIF_HSYNC
GPIO14	CAMIF_VSYNC
GPIO15	CAMIF_MCLK
GPIO16	NC
GPIO17	NC
GPIO18	FM_INT
GPIO19	MEMSINT_1
GPIO20	MEMSINT_2
GPIO21	NC
GPIO22	NC
GPIO23	COMPASS_RST
GPIO24	PM_INT_N
GPIO25	PS_HOLD_MSM
GPIO26	HEADSET_EN
GPIO27	LCD_BL_CL
GPIO28	NC
GPIO29	ATT_TOUCH
GPIO30	FM_RST
GPIO31	H_RIGHT
GPIO32	H_LEFT
GPIO33	KEYROW_3
GPIO34	KEYROW_2
GPIO35	KEYROW_1
GPIO36	H_DOWN
GPIO37	H_UP
GPIO38	JAGBALL_CTL
GPIO39	KEYCOL_3
GPIO40	KEYCOL_2

GPIO41	KEYCOL_1
GPIO42	MSM_WAKES_BT
GPIO43	UART1_RFR_N
GPIO44	UART1_CTS_N
GPIO45	UART1_RX_DATA
GPIO46	UART1_TX_DATA
GPIO47	E_RUIM_CLK_I
GPIO48	E_RUIM_RST_I
GPIO49	NC
GPIO50	E_RUIM_IO_I
GPIO51	TF_DATA3
GPIO52	TF_DATA2
GPIO53	TF_DATA1
GPIO54	TF_DATA0
GPIO55	TF_CMD
GPIO56	TF_CLK
GPIO57	NC
GPIO58	SSBI_0
GPIO59	SSBI_1
GPIO60	I2C_SCL
GPIO61	I2C_SDA
GPIO62	SDC2_CLK
GPIO63	SDC2_CMD
GPIO64	SDC2_DATA3
GPIO65	SDC2_DATA2
GPIO66	SDC2_DATA1
GPIO67	SDC2_DATA0
GPIO68	AUX_PCM_DOUT
GPIO69	AUX_PCM_DIN
GPIO70	AUX_PCM_SYNC
GPIO71	AUX_PCM_CLK
GPIO72	NC
GPIO73	NC
GPIO74	NC

GPIO75	NC
GPIO76	NC
GPIO77	NC
GPIO78	NC
GPIO79	NC
GPIO80	NC
GPIO81	GPS_LNA_EN
GPIO82	NC
GPIO83	BT_WAKES_MSM
GPIO84	NC
GPIO85	NC
GPIO86	NC
GPIO87	NC
GPIO88	BT_PWR_ON
GPIO89	CAMIF_RESET
GPIO90	CAM_SHUTDOWN_OUTS
GPIO91	VCM_POWERDOWN
GPIO92	CAM_SHUTDOWN_INS
GPIO93	HS_DETECT
GPIO94	JAM_DET_INT
GPIO95	BOOT_SCUR
GPIO96	TOUCH_RST
GPIO97	NC
GPIO98	LCD_DATA_R5
GPIO99	LCD_DATA_R6
GPIO100	LCD_DATA_R7
GPIO101	LCD_RESET
GPIO102	LCD_SPI_OUT
GPIO103	NC
GPIO104	PA_R1
GPIO105	TCXO_EN
GPIO106	PM_SBDT
GPIO107	COMPASS_INT
GPIO108	NC

The type and specification of the components refer to the BOM

				NA	2009-04-26
				ECA NO	DATE
DESIGNED	JI JIANGHUI 66114	HC1M860M		00597618	
REVIEWED	XU XUESONG 57251	VER	PART_NUMBER	SHEET 17 OF 34	
			03020VQA	HUAWEI TECH CO.,LTD.	

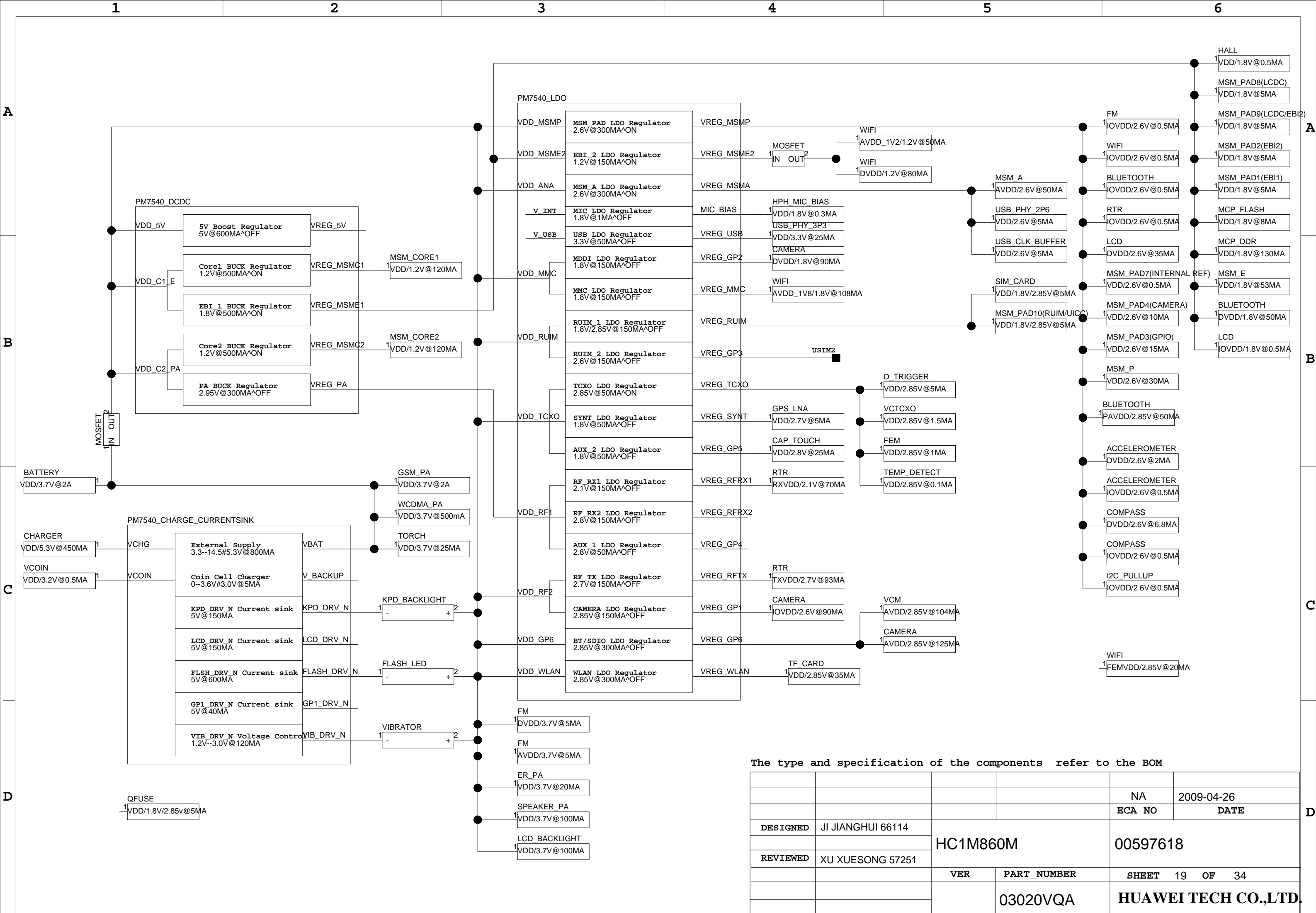

The type and specification of the components refer to the BOM

				NA	2009-04-26
				ECA NO	DATE
DESIGNED	JI JIANGHUI 66114	HC1M860M		00597618	
REVIEWED	XU XUESONG 57251	VER	PART_NUMBER	SHEET 19 OF 34	
			03020VQA	HUAWEI TECH CO.,LTD.	

20. SPECIAL

A

A

B

B

C

C

D

D

The type and specification of the components refer to the BOM

				NA	2009-04-26
				ECA NO	DATE
DESIGNED	JI JIANGHUI 66114	HC1M860M		00597618	
REVIEWED	XU XUESONG 57251				
		VER	PART_NUMBER	SHEET 20 OF 34	
			03020VQA	HUAWEI TECH CO.,LTD.	

RF INPUT OUPUT PORTS

1 RF INPUT OUPUT PORTS

2 19.2MHz VCTCXO

3 PRX AND DRX CIRCUIT

4 TX CELL DUPLEXER & PA

5 TX PCS DUPLEXER & PA

6 TX AWS DUPLEXER & PA

7 GPS FRONT-END

8 RTR6500

9 RTR6500 POWER DISTRIBUTION

10 NC

11 RX INTERSTAGE SAW FILTER

12 Bluetooth

13 AR6002 POWER AND CONTROL

14 RF TRANSCEIVER_WIFI

15 TX PA_WIFI

For CDMA PA Control

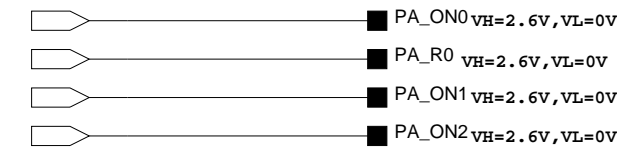

For RTR6500 Control

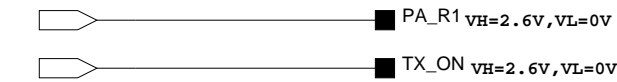

TX IQ Input

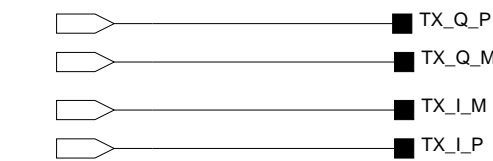

For WLAN Control

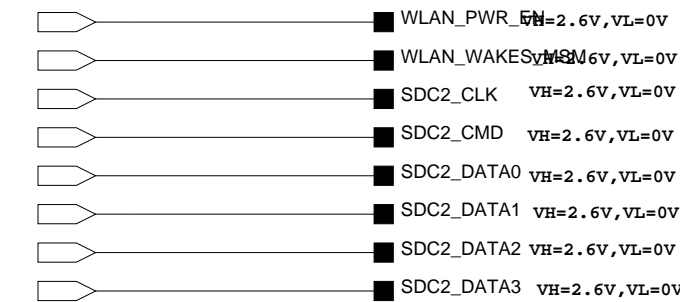

SBI Control Line

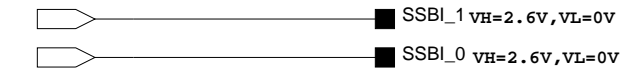

For GPS Control

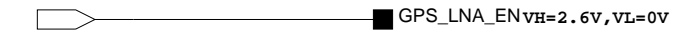

For VCTCXO Control



Power Supply For RF

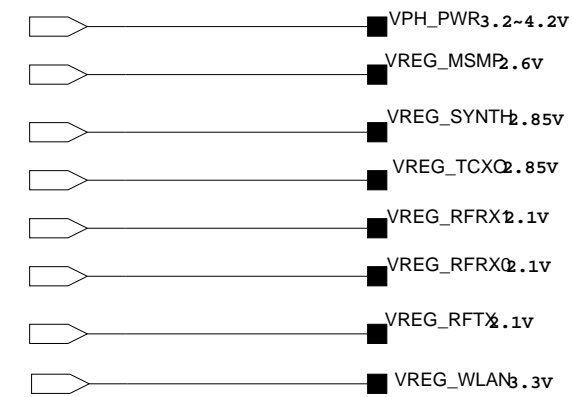

For Antenna Switch Control

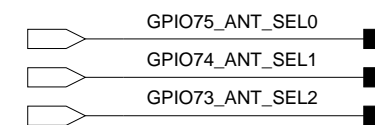

RX IQ Output

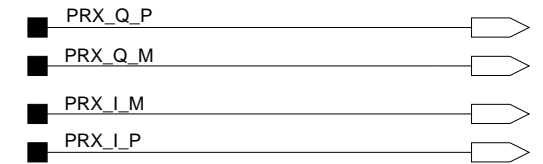

GPS RX IQ Output

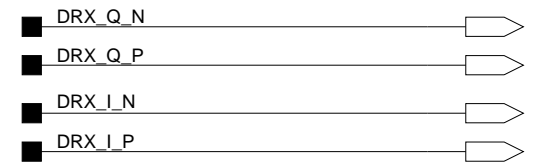

For BT

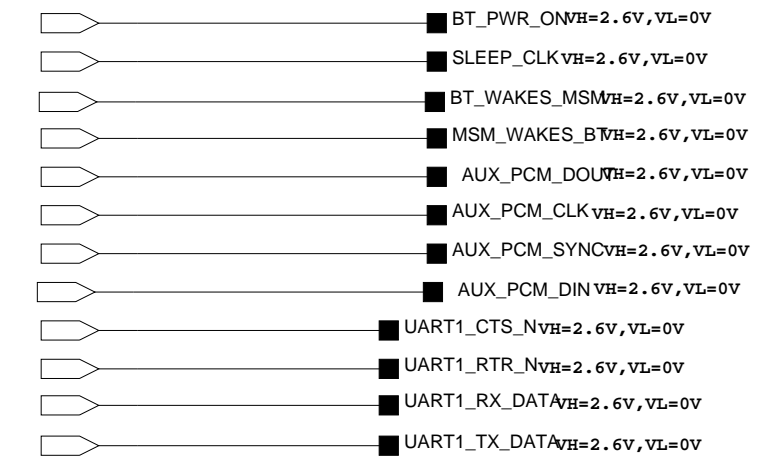

Other Control Line

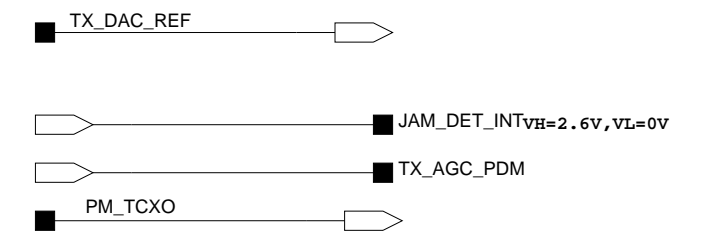

The type and specification of the components refer to the BOM

				NA	2009-04-26
				ECA NO	DATE
DESIGNED	FAN BAOMIN 39364	HC1M860M		00597618	
REVIEWED	XU XUESONG 57251	VER	PART_NUMBER	SHEET 21 OF 34	
			03020VQA	HUAWEI TECH CO.,LTD.	

22.19.2MHz VCTCXO

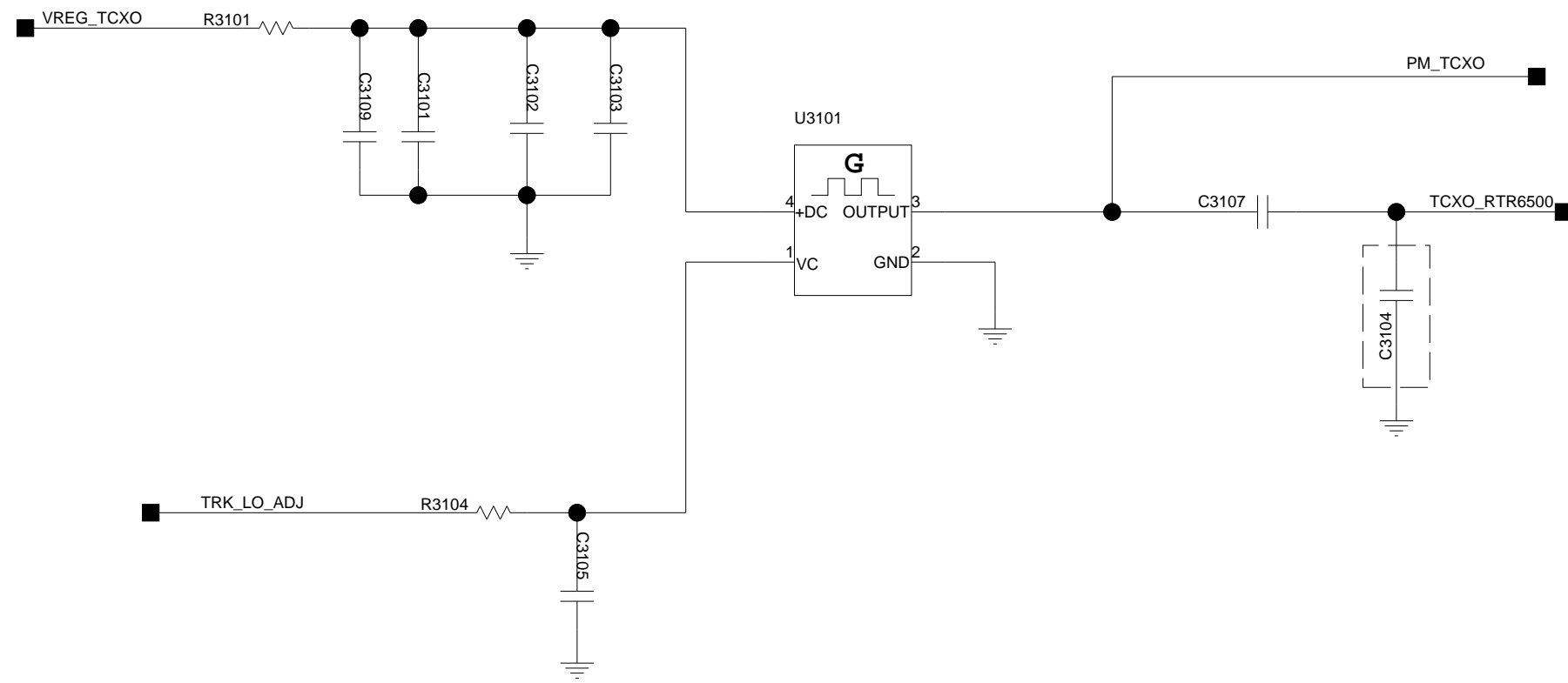

The type and specification of the components refer to the BOM

				NA	2009-04-26
				ECA NO	DATE
DESIGNED	FAN BAOMIN 39364	HC1M860M		00597618	
REVIEWED	XU XUESONG 57251				
		VER	PART_NUMBER	SHEET 22 OF 34	
			03020VQA	HUAWEI TECH CO.,LTD.	

23.PRX CIRCUIT

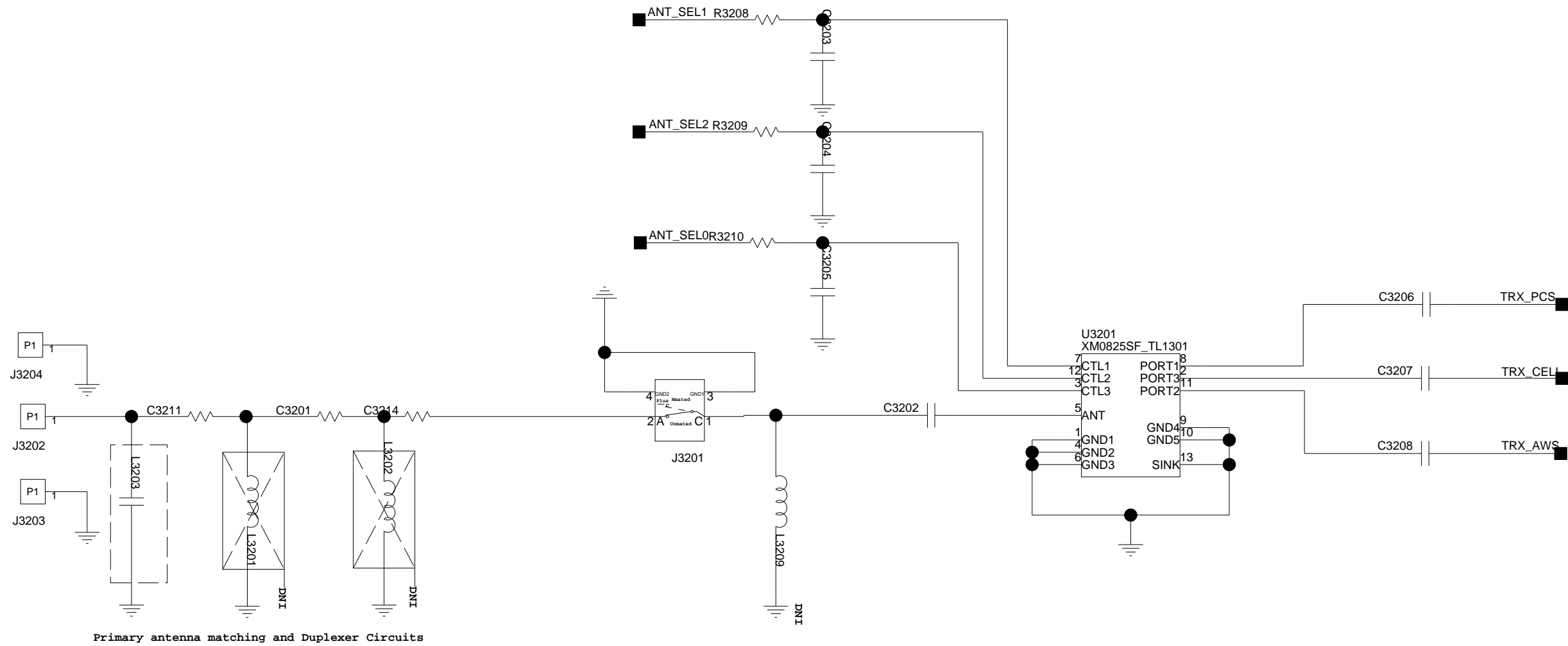

Primary antenna matching and Duplexer Circuits

PATH	MODE	ANT_SEL0	ANT_SEL1	ANT_SEL2
ANT-PORT3	CELL TRX	H	L	L
ANT-PORT1	PCS TRX	L	H	L
ANT-PORT2	AWS TRX	L	L	H

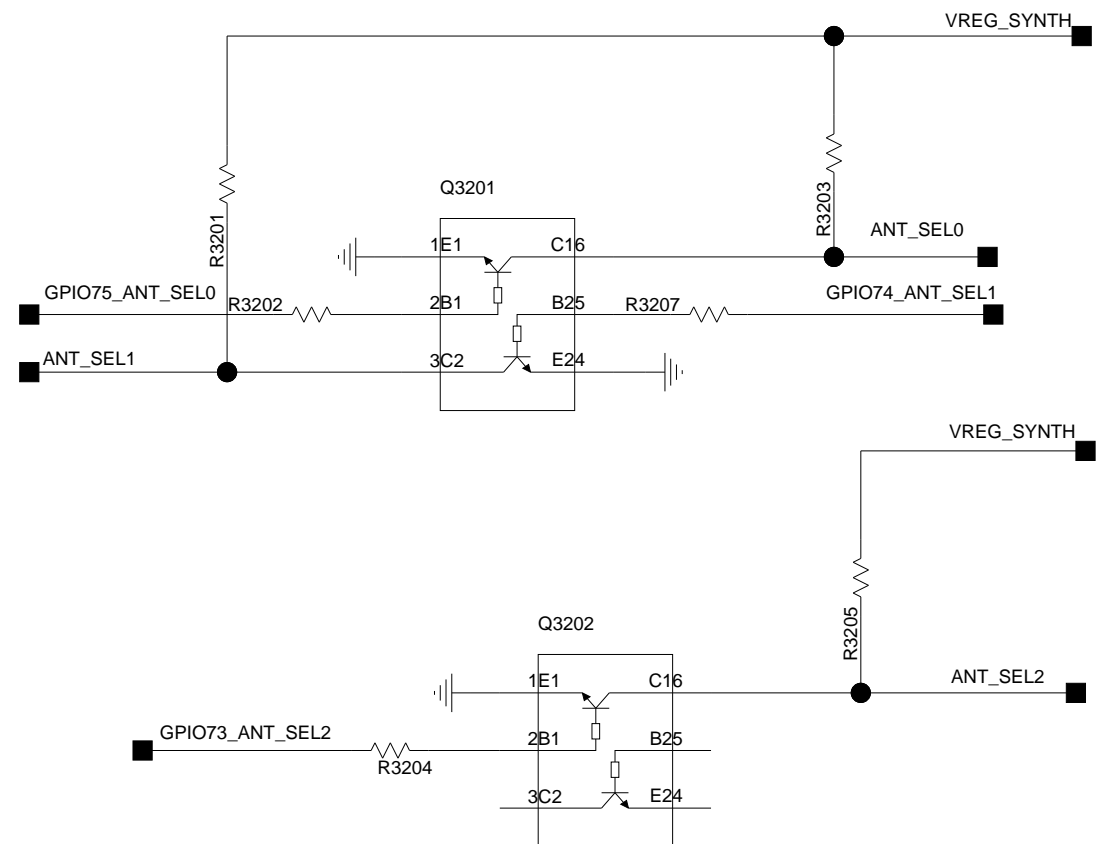

The type and specification of the components refer to the BOM

				NA	2009-04-26
				ECA NO	DATE
DESIGNED	FANBAOMIN 39364	HC1M860M		00597618	
REVIEWED	XXXX	VER	PART_NUMBER	SHEET 23 OF 34	
			03020VQA	HUAWAI TECH CO.,LTD.	

24.TX CELL DUPLEXER & PA

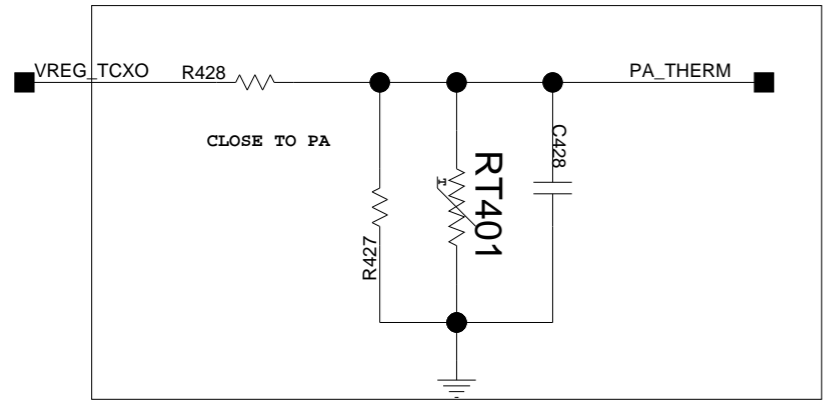
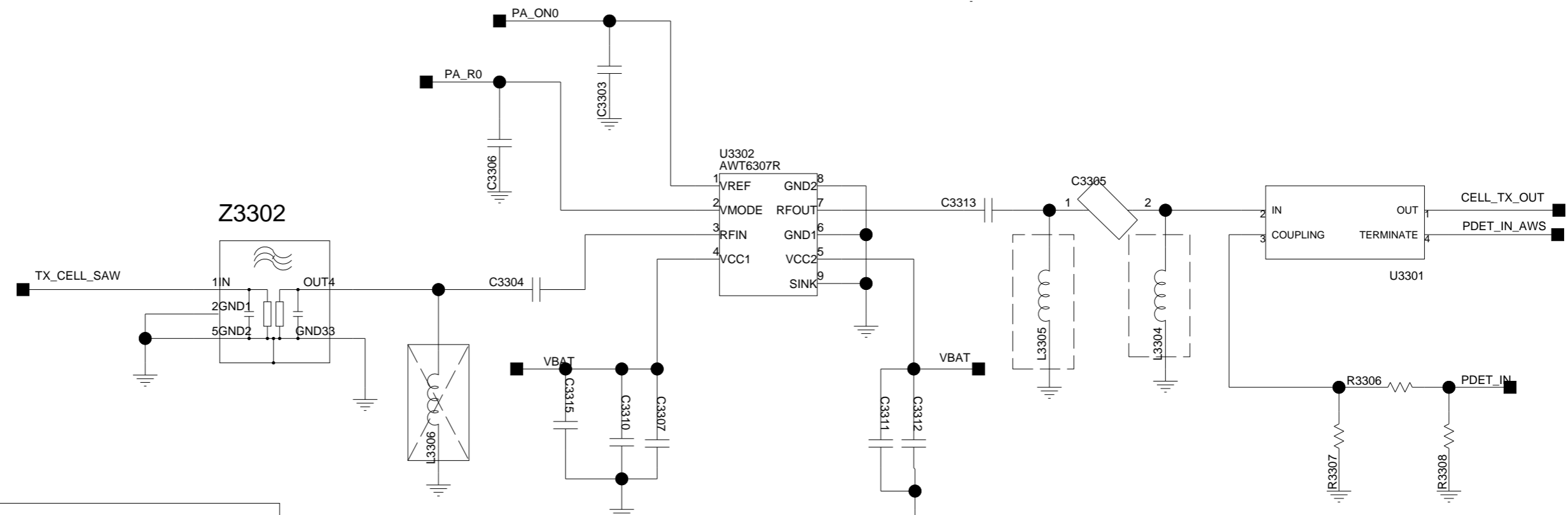
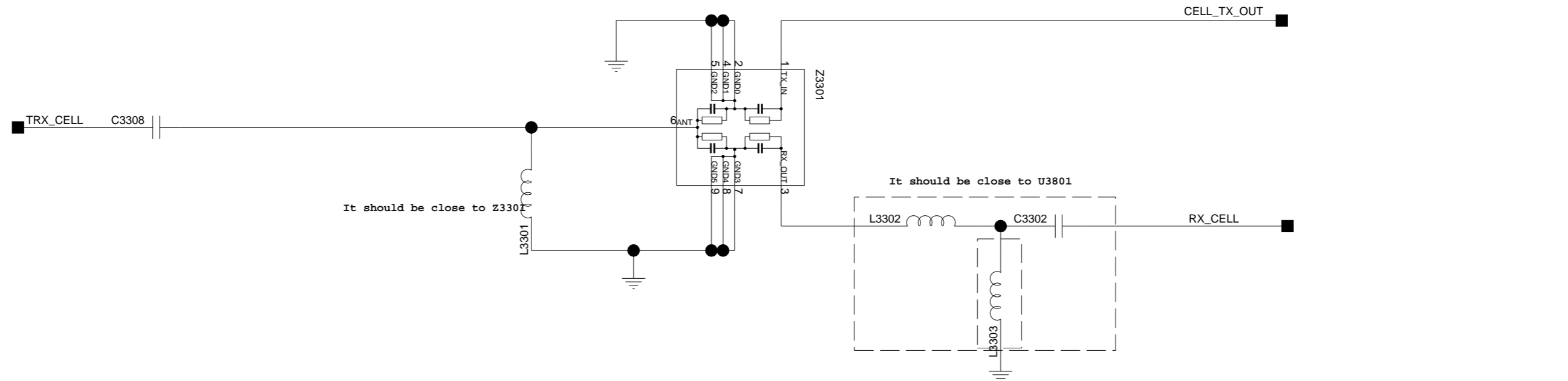

The type and specification of the components refer to the BOM

				NA	2009-04-26
				ECA NO	DATE
DESIGNED	FANBAOMIN 39364	HC1M860M		00597618	
REVIEWED	XUXUESONG 57251	VER	PART_NUMBER	SHEET 24 OF 34	
			03020VQA	HUAWEI TECH CO.,LTD.	

25.TX PCS DUPLEXER & PA

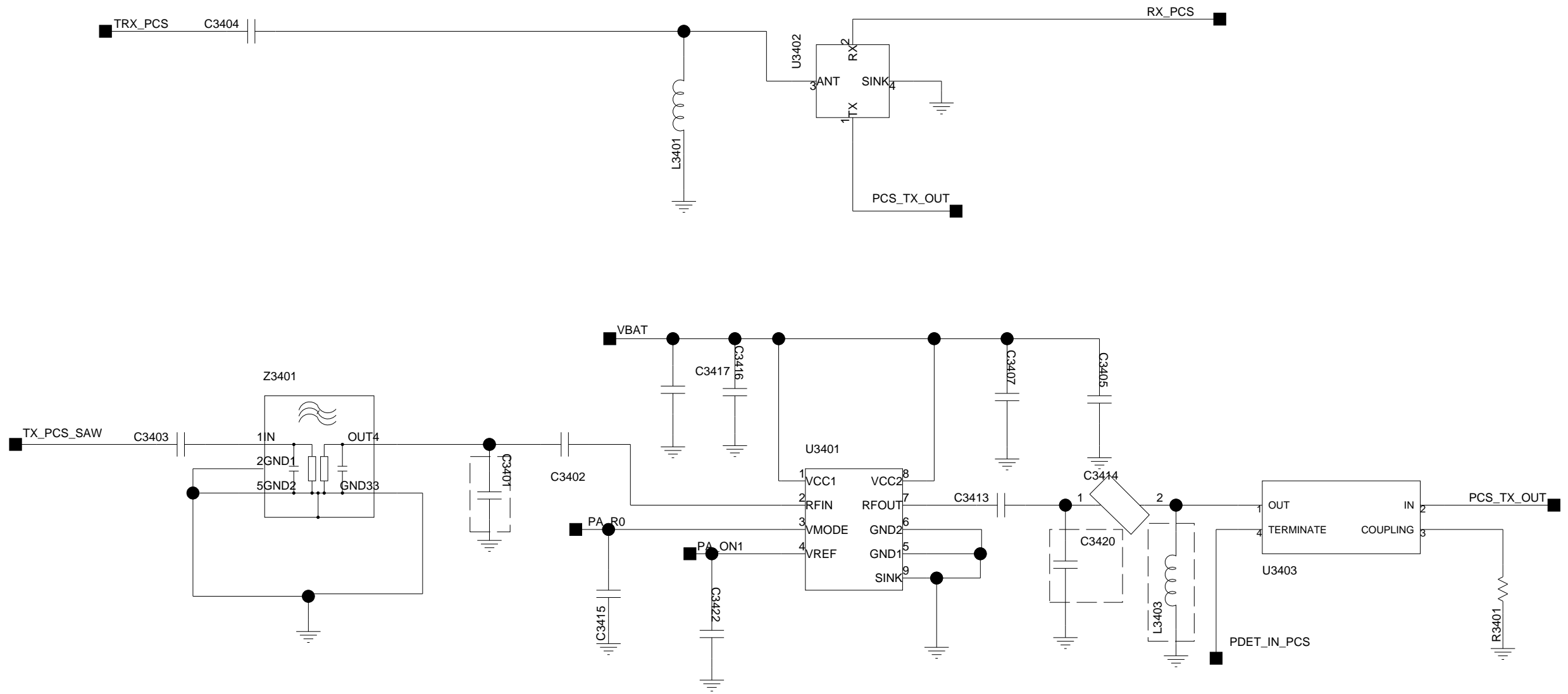

The type and specification of the components refer to the BOM

				NA	2009-04-26-15
				ECA NO	DATE
DESIGNED	ZHANGTAO 62190	HC1M860M		00597618	
REVIEWED	LIUJUNXIA 44816				
		VER	PART_NUMBER	SHEET	25 OF 34
			03020VQA	HUAWEI TECH CO.,LTD.	

26.TX AWS DUPLEXER & PA

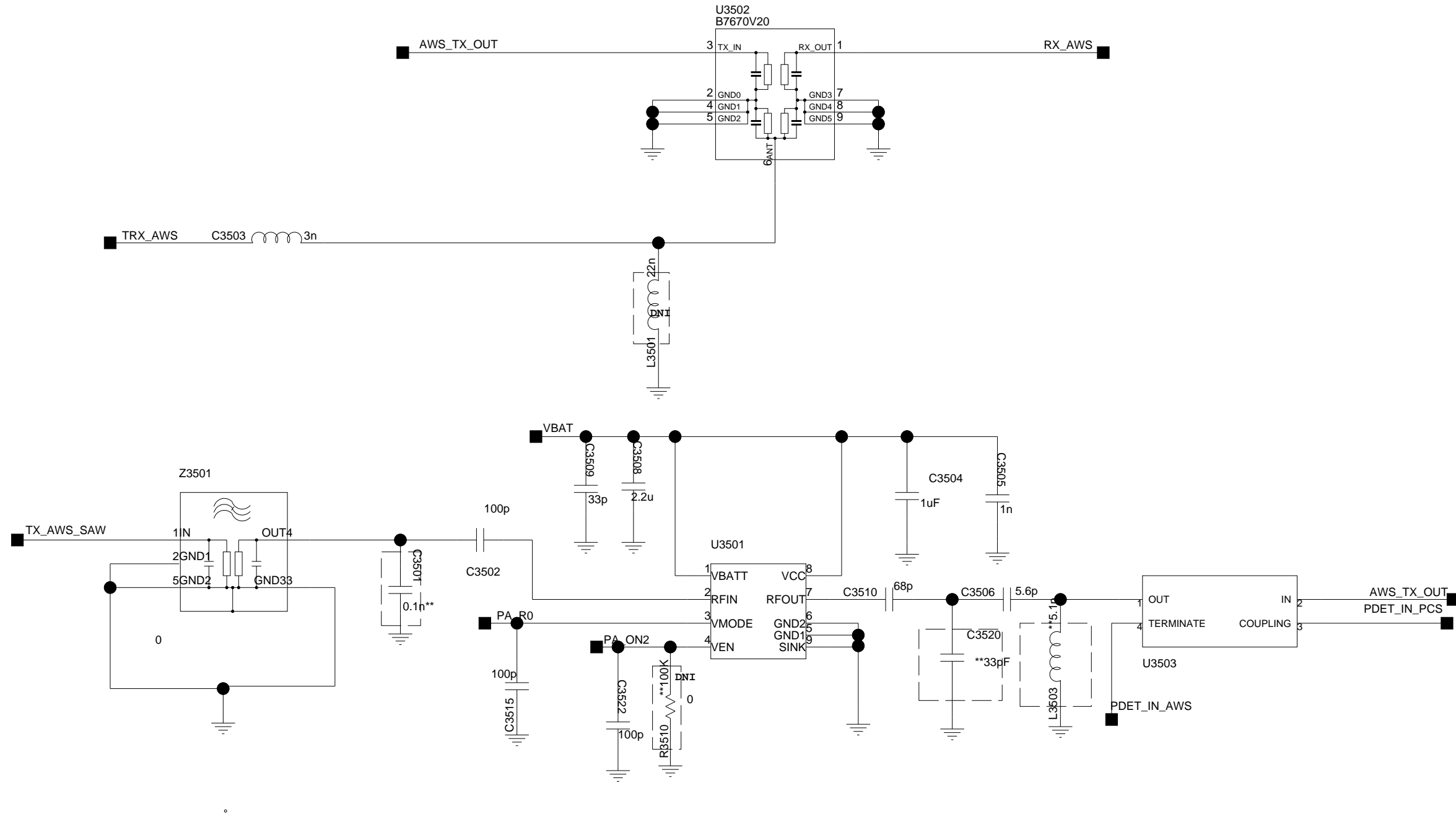

The type and specification of the components refer to the BOM

				NA	2009-04-26-15
				ECA NO	DATE
DESIGNED	ZHANGTAO 62190	HC1M860M		00597618	
REVIEWED	LIUJUNXIA 44816				
		VER	PART_NUMBER	SHEET	26 OF 34
			03020VQA	HUAWEI TECH CO.,LTD.	

27.GPS Front

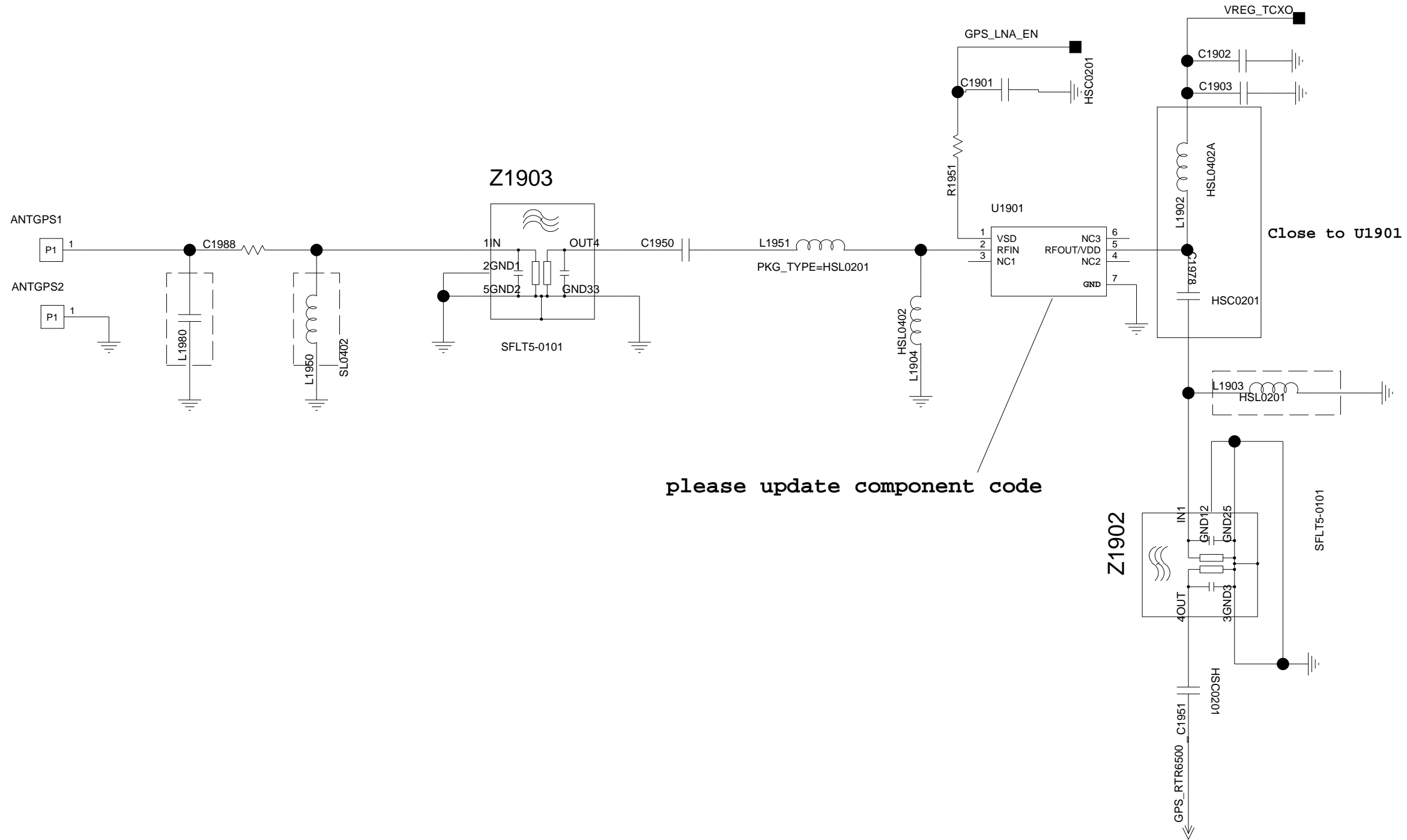

please update component code

The type and specification of the components refer to the BOM

					7-13-2010_14:19
				NA	2009-04-26
				ECA NO	DATE
DESIGNED	LIUWENCHENG 00113711	HC1M860M		00597618	
REVIEWED	YANXINMIAO 00142024				
		VER	PART_NUMBER	SHEET 27 OF 34	
			03020VQA	HUAWEI TECH CO.,LTD.	

28.RTR 6500

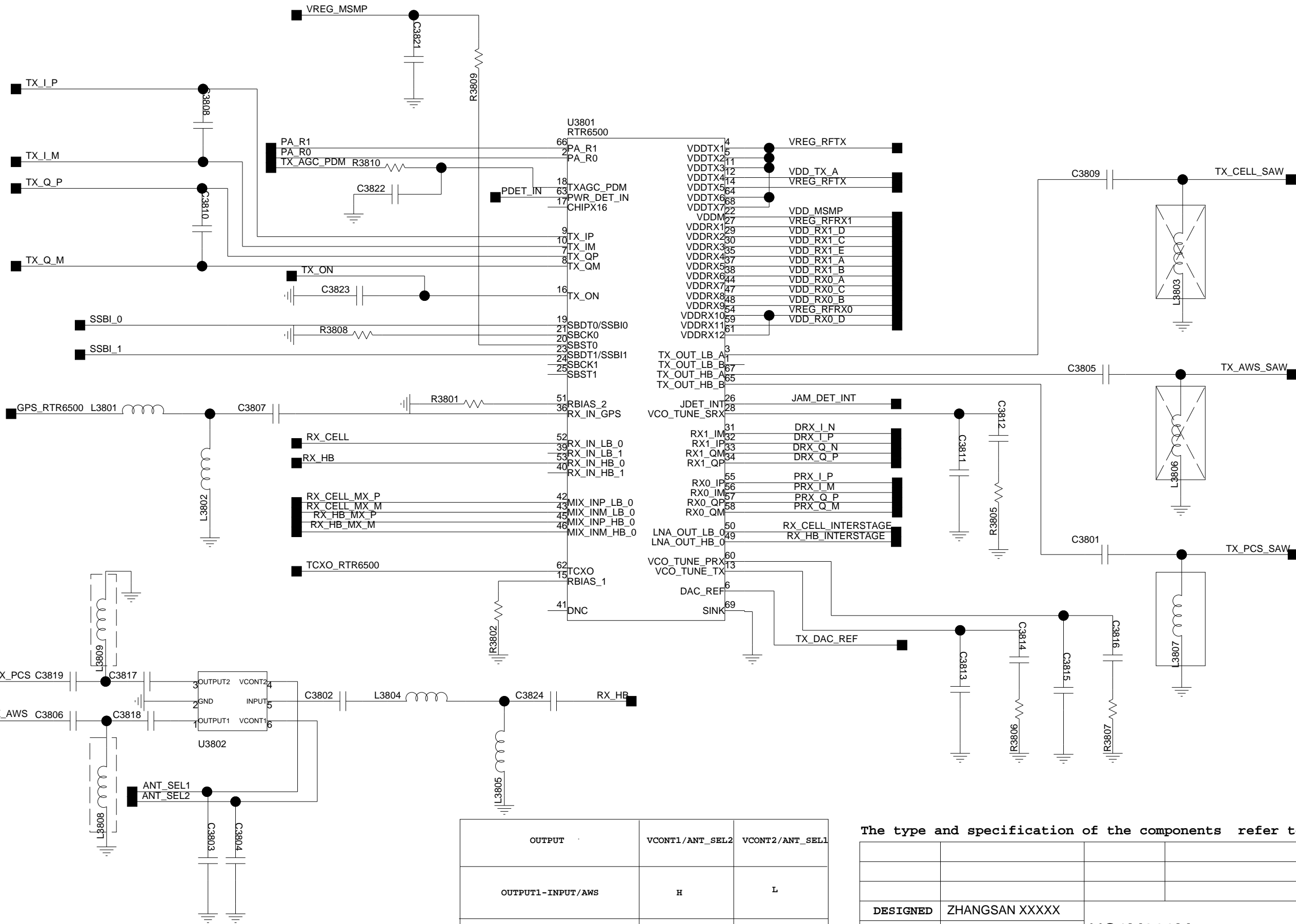

OUTPUT	VCONT1/ANT_SEL2	VCONT2/ANT_SEL1
OUTPUT1-INPUT/AWS	H	L
OUTPUT2-INPUT/PCS	L	H

The type and specification of the components refer to the BOM

DESIGNED	ZHANGSAN XXXXX	HC1M860M	NA	2009-04-26
REVIEWED	LISI XXXXX		ECA NO	DATE
		VER	PART_NUMBER	SHEET 28 OF 34
		03020VQA		HUAWEI TECH CO.,LTD.

29.RTR6500 POWER DISTRIBUTION

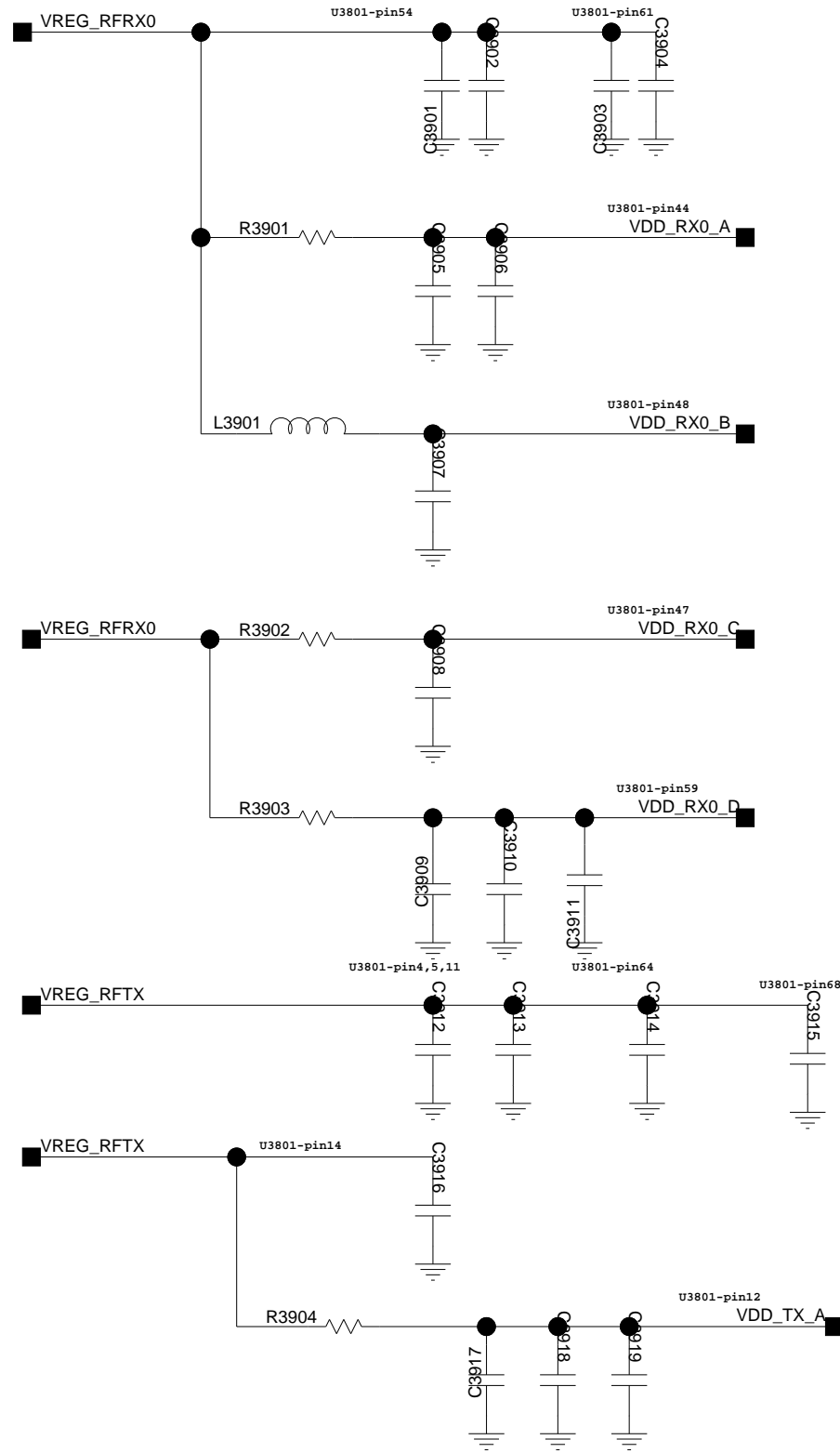

0603 size should be used for C3817 in case higher value needed

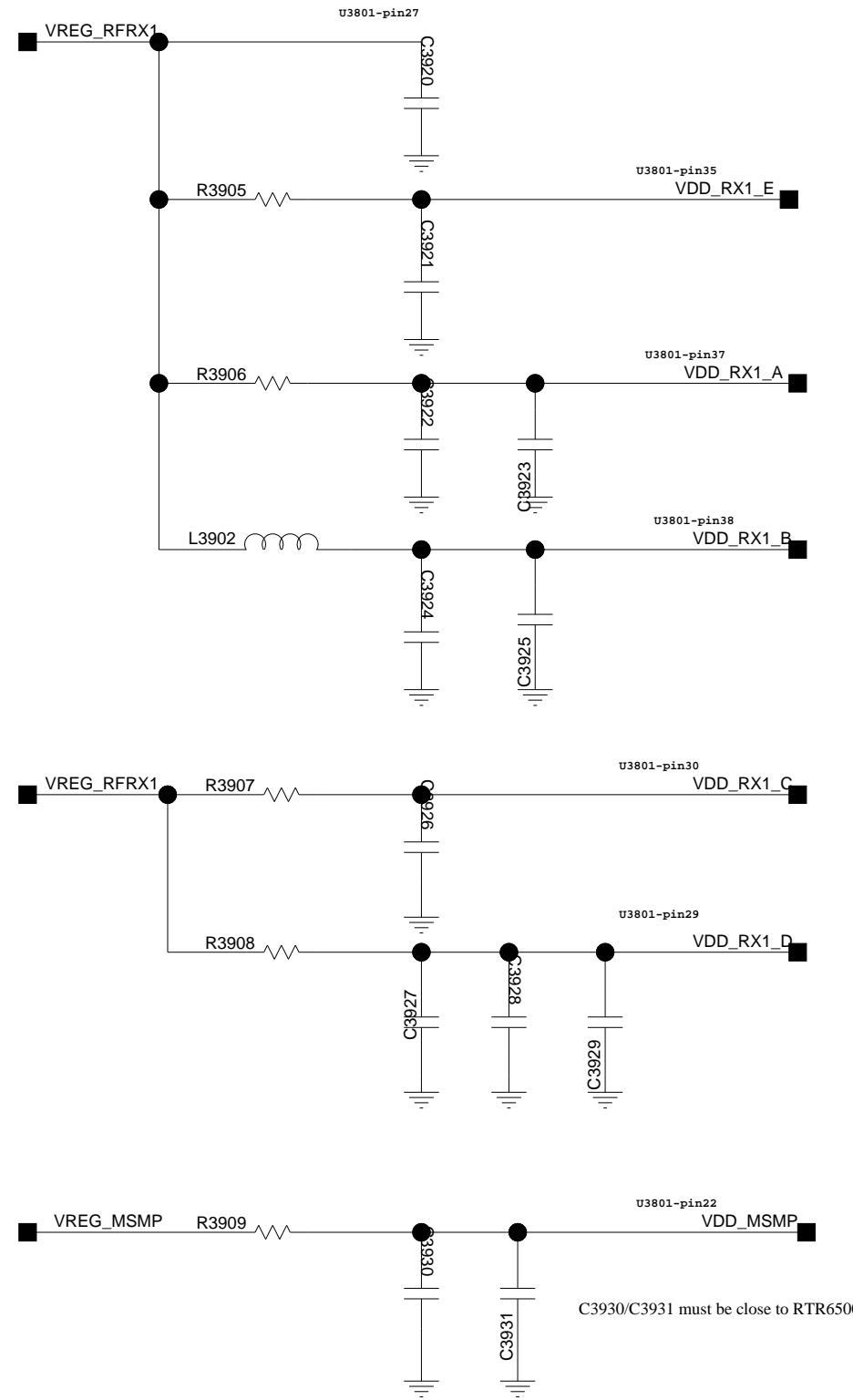

C3930/C3931 must be close to RTR6500

The type and specification of the components refer to the BOM

				NA	2009-04-26
				ECA NO	DATE
DESIGNED	FAN BAOMIN 39364	HC1M860M		00597618	
REVIEWED	XU XUESONG 57251	VER	PART_NUMBER	SHEET 29 OF 34	
			03020VQA	HUAWEI TECH CO.,LTD.	

30.RX HB INTERSTAGE SAW FILTER

It should be close to U3801

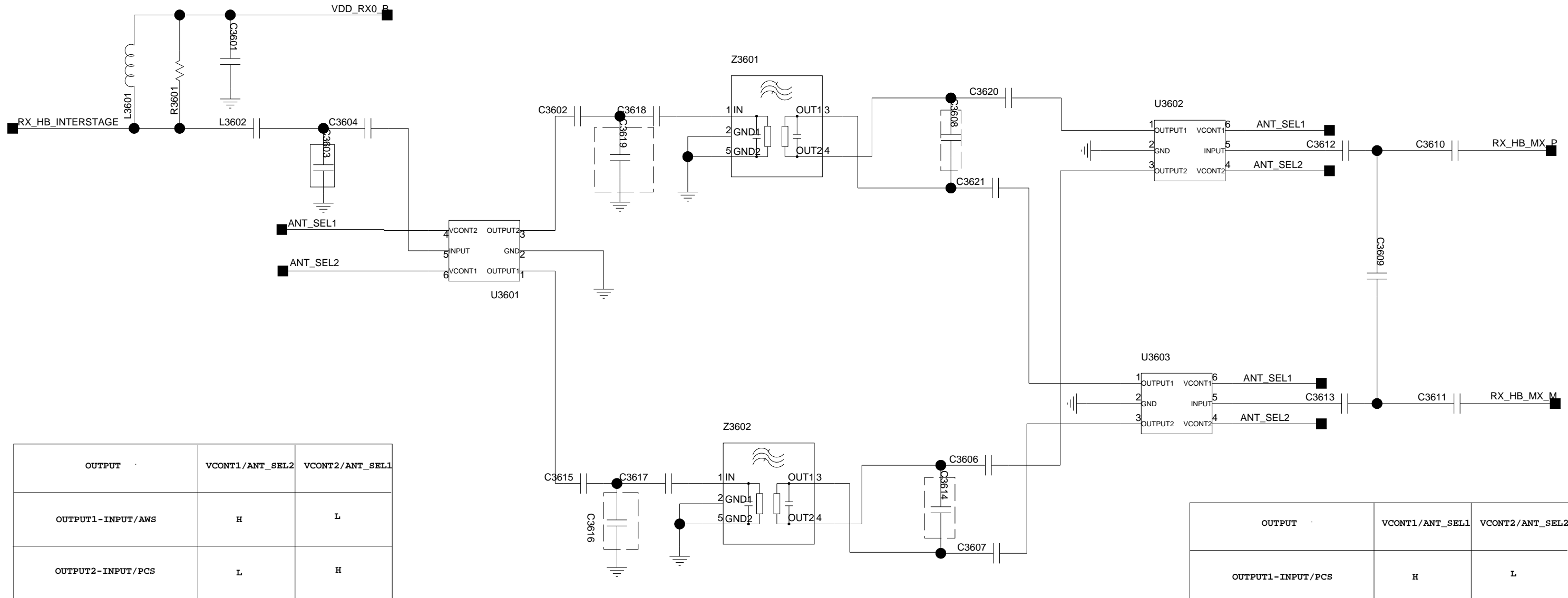

OUTPUT	VCONT1/ANT_SEL2	VCONT2/ANT_SEL1
OUTPUT1-INPUT/AWS	H	L
OUTPUT2-INPUT/PCS	L	H

OUTPUT	VCONT1/ANT_SEL1	VCONT2/ANT_SEL2
OUTPUT1-INPUT/PCS	H	L
OUTPUT2-INPUT/AWS	L	H

The type and specification of the components refer to the BOM

				NA	2009-04-26
				ECA NO	DATE
DESIGNED	FANBAOMIN 39364	HC1M860M		00597618	
REVIEWED	XXXX	VER	PART_NUMBER	SHEET 30 OF 34	
			03020VQA	HUAWEI TECH CO.,LTD.	

31.RX INTERSTAGE SAW FILTER

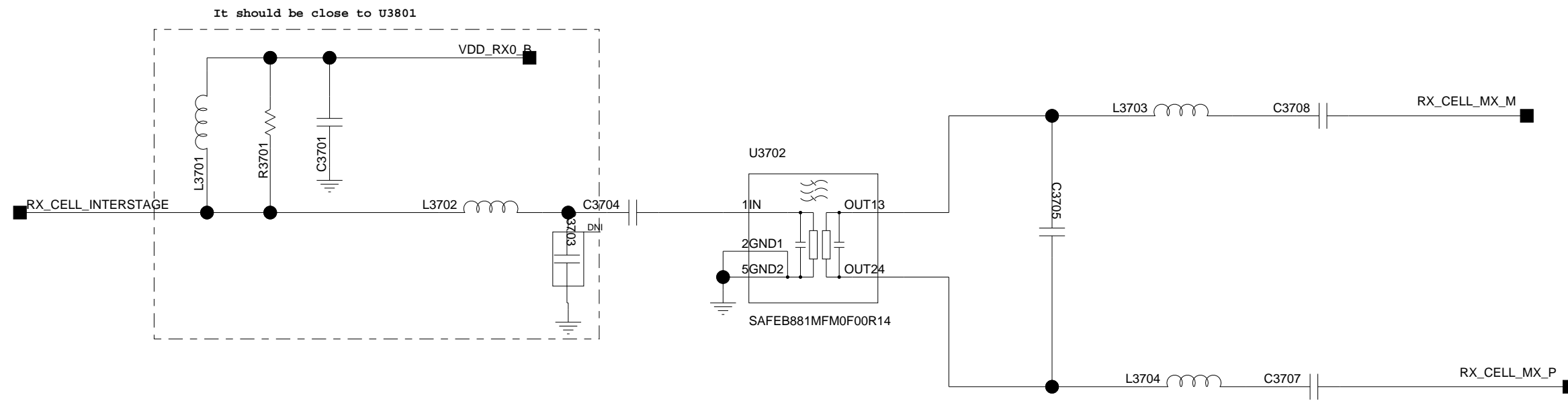

The type and specification of the components refer to the BOM

				NA	2009-04-26
				ECA NO	DATE
DESIGNED	XIONGQIANG 69149	HC1M860M		00597618	
REVIEWED	LILIN 37448				
		VER	PART_NUMBER	SHEET 31 OF 34	
			03020VQA	HUAWEI TECH CO.,LTD.	

32. WIFI BCM4319

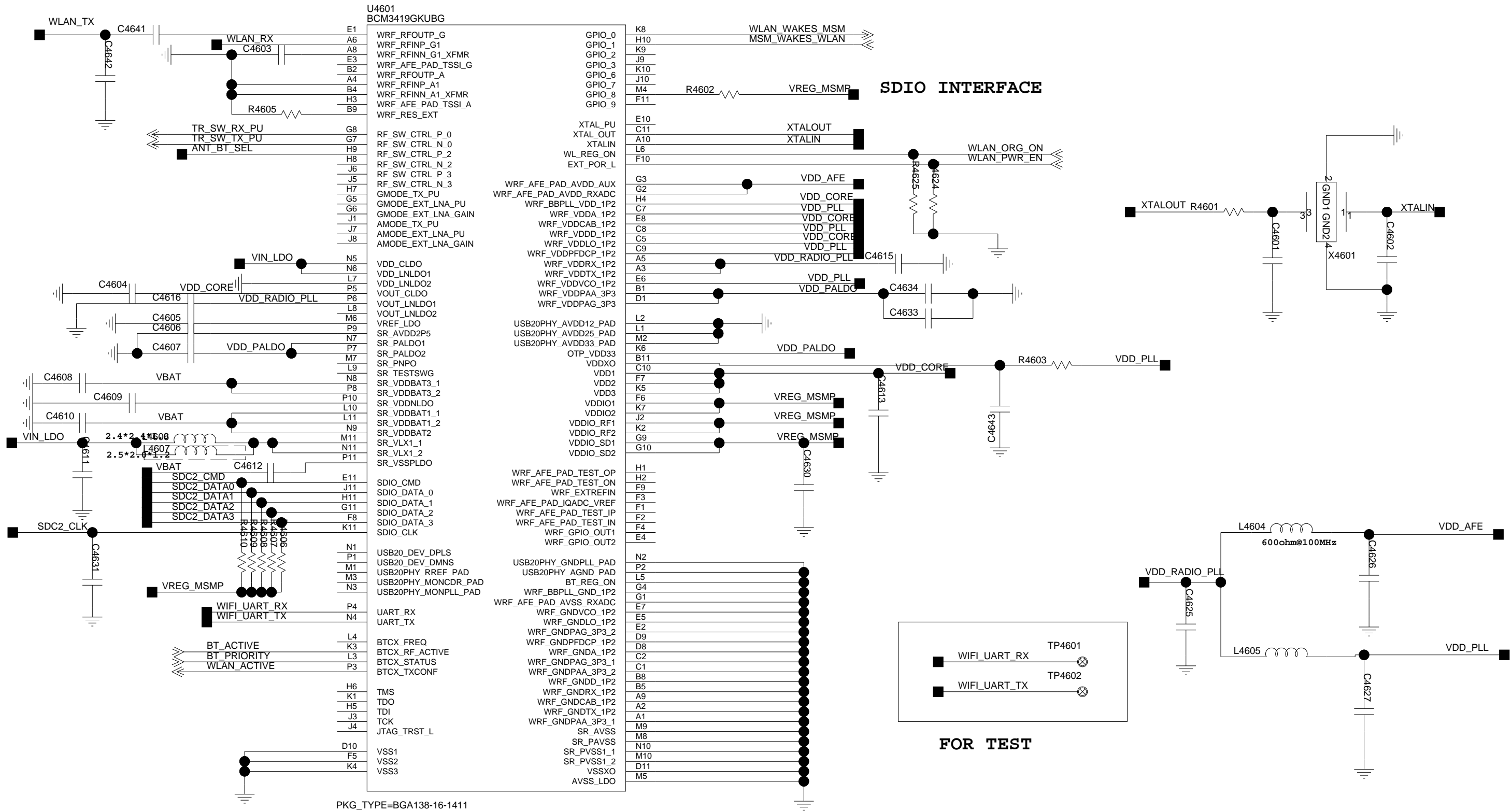

The type and specification of the components refer to the BOM

DESIGNED	CHENWEICONG 00135031	HC1M860M	00597618
REVIEWED	LIUSHUI 62346	03020VQA	HUAWEI TECH CO.,LTD.
		VER	PART_NUMBER
		SHEET 32 OF 34	
		DATE	
		ECA NO	
		NA	
		2009-04-26	

33. WIFI & BT ANT AND CONTROL

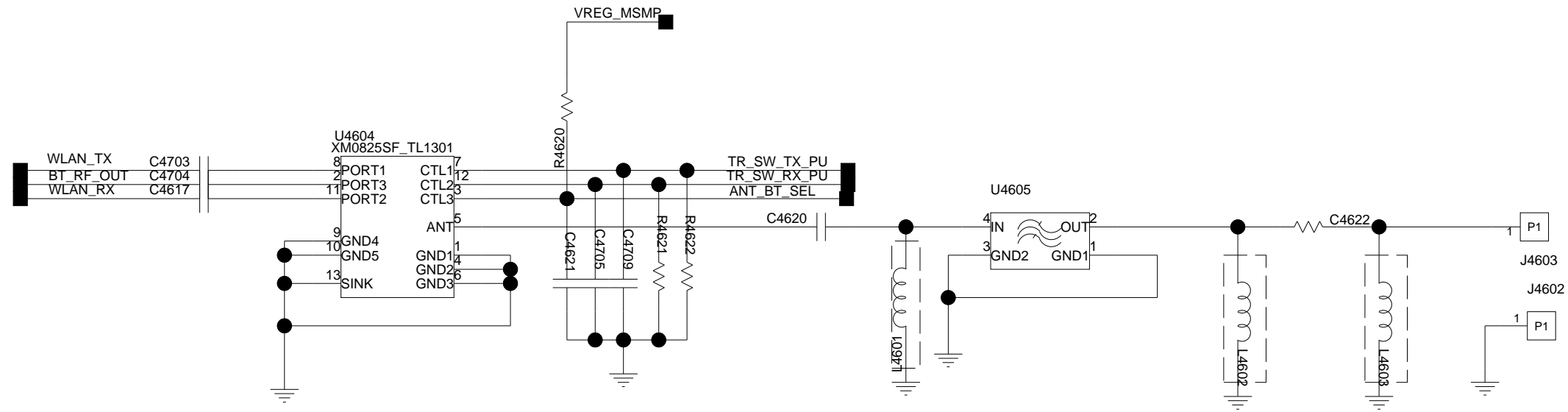

PATH	CTL1	CTL2	CTL3
ANT_PORT1	H	L	L
ANT_PORT2	L	H	L
ANT_PORT3	L	L	H

The type and specification of the components refer to the BOM

				NA	2009-04-26
				ECA NO	DATE
DESIGNED	BAI XUESONG 00131181	HC1M860M		00597618	
REVIEWED	ZENG WEICAI 65065	VER	PART_NUMBER	SHEET 33 OF 34	
			03020VQA	HUAWEI TECH CO.,LTD.	

34. Bluetooth

Install 32M crystal

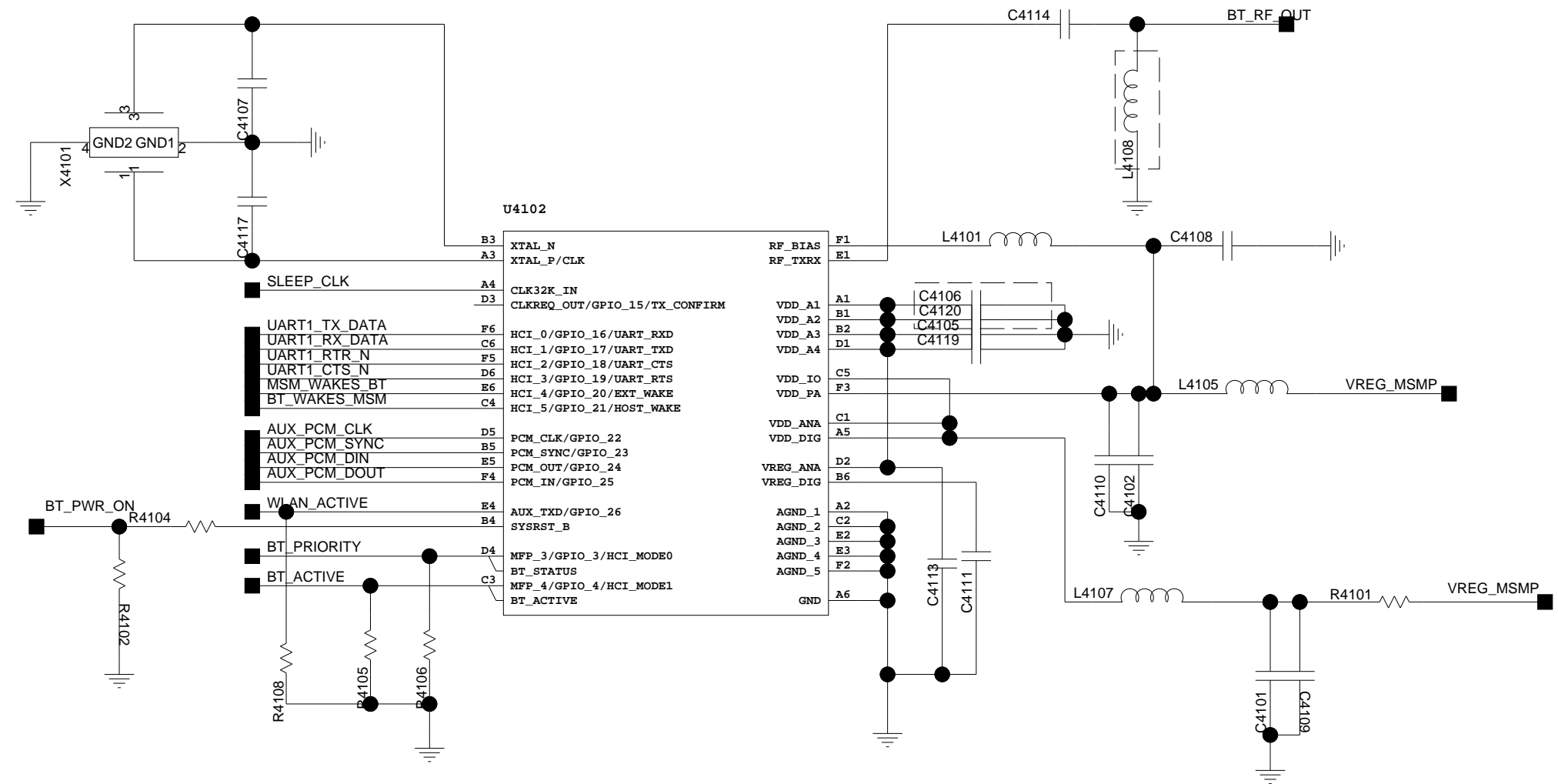

The type and specification of the components refer to the BOM

				NA	2009-04-26
				ECA NO	DATE
DESIGNED	FAN BAOMIN 39364	HC1M860M		00597618	
REVIEWED	XU XUESONG 57251	VER	PART_NUMBER	SHEET 34 OF 34	
			03020VQA	HUAWEI TECH CO.,LTD.	