



# EMC Test Report

**Product Name: Mobile WiFi**

**Model Number: HWD36**

**FCC ID: QISHWD36**

**Report No: SYBH(Z-EMC)096092017-2**

**Global Compliance and Testing Center of Huawei Technologies Co., Ltd**

Administration Building, Headquarters of Huawei Technologies Co., Ltd., Bantian, Longgang District,  
Shenzhen, 518129, P.R.C

Tel: +86 755 28780808 Fax: +86 755 89652518



## Notice

1. The laboratory has obtained the accreditation of China National Accreditation Service for Conformity Assessment (CNAS), and accreditation number: L0310.
2. The laboratory has passed the accreditation by The American Association for Laboratory Accreditation (A2LA). The accreditation number is 2174.01
3. The laboratory has been listed by Industry Canada to perform electromagnetic emission measurements. The recognition numbers of test site are 6369A-1.
4. The laboratory (Reliability Lab of Huawei Technologies Co., Ltd) is also named as “Global Compliance and Testing Center of Huawei Technologies Co., Ltd”, the both names have coexisted since 2009.
5. The laboratory has been recognized by the US Federal Communications Commission (FCC) to perform compliance testing subject to the Commission's Declaration Of Conformity (DOC) and Certification rules. The Designation Number is CN1173, and the Test Firm Registration Number is 294140.”
6. The test report is invalid if not marked with the stamps or the signatures of the persons responsible for performing, revising and approving the test report.
7. The test report is invalid if there is any evidence of erasure and/or falsification.
8. If there is any dissidence for the test report, please file objection to the test centre within 15 days from the date of receiving the test report.
9. Normally, the test report is only responsible for the samples that have undergone the test.
10. Context of the test report cannot be used partially or in full for publicity and/or promotional purposes without previous written approval of the laboratory.



**Applicant:** Huawei Technologies Co., Ltd.

**Address:** Administration Building, Headquarters of Huawei Technologies Co., Ltd., Bantian, Longgang District, Shenzhen, 518129, P.R.C

**Date of Receipt Test Item:** Oct.30,2017

**Start Date of Test:** Nov.01,2017

**End Date of Test:** Nov.05,2017

**Test Result:** Pass

<b>Approved By (Lab Manager)</b>	<u>2017-11-07</u>	<u>Roger Zhang</u>	<i>Roger Zhang</i>
	<b>Date</b>	<b>Name</b>	<b>Signature</b>
<b>Prepared by (Test Engineer)</b>	<u>2017-11-07</u>	<u>Luo Wei</u>	<i>Luo wei</i>
	<b>Date</b>	<b>Name</b>	<b>Signature</b>



## TABLE OF CONTENT

1	General Information.....	5
1.1	EUT Description .....	5
1.2	Test Site Information .....	6
1.3	Applied Standards .....	6
2	Summary of Results .....	7
3	System Configuration during EMC Test.....	8
3.1	Test Mode.....	8
3.2	Test System Configuration.....	8
3.3	Cables Used during Test.....	9
3.4	Associated Equipment Used during Test.....	9
4	Electromagnetic Interference (EMI) .....	10
4.1	Radiated Disturbance 30MHz to 18GHz.....	10
4.2	Conducted Disturbance 0.15 MHz to 30MHz.....	12
5	Main Test Instruments .....	13
6	System Measurement Uncertainty .....	14
7	Test Data and Graph .....	15
7.1	Radiated Disturbance .....	15
7.2	Conducted Disturbance.....	17



## 1 General Information

### 1.1 EUT Description

EUT Description	
Product Name	Mobile WiFi
Model Number	HWD36
Serials Number	ACN0117821000236
Input Rated Voltage	--- 3.8V
TX Frequency	WCDMA BAND 2: 1850MHz to 1910MHz WCDMA BAND 5: 824MHz to 849MHz LTE BAND 5: 824MHz to 849MHz LTE BAND 17: 704MHz to 716MHz 2.4G WiFi: 2400MHz to 2472MHz BT(BR/EDR2.1, BLE4.1): 2400MHz to 2483.5MHz
RX Frequency	WCDMA BAND 2: 1930MHz to 1990MHz WCDMA BAND 5: 869MHz to 894MHz LTE BAND 5: 869MHz to 894MHz LTE BAND 17: 734MHz to 746MHz 2.4G WiFi: 2400MHz to 2472MHz BT(BR/EDR2.1, BLE4.1): 2400MHz to 2483.5MHz NFC: 13.56MHz
HW Version	CL1KD16M
SW Version	11.450.03.82.824

Remark: The above EUT's information is declared by manufacturer. Please refer to the specifications or user's manual for more detailed information.



### 1.2 Test Site Information

Test Site:	RELIABILITY LABORATORY OF HUAWEI TECHNOLOGIES CO., LTD.
Test Site Location:	Administration Building, Headquarters of Huawei Technologies Co., Ltd., Bantian, Longgang District, Shenzhen, 518129, P.R.C

### 1.3 Applied Standards

APPLIED STANDARD

47 CFR FCC Part 15:2016, Subpart B

## 2 Summary of Results

Summary of Results				
Test Items	Test Mode	Performance Class & Required Performance Criteria	Result	Site
<u>Radiated Emissions</u> <input checked="" type="checkbox"/> Enclosure Port	Mode 1 Mode 3	CLASS B	Pass	Site1
<u>Conducted Emissions</u> <input checked="" type="checkbox"/> DC Power Port <input checked="" type="checkbox"/> AC Power Port <input type="checkbox"/> Telecommunication Ports	Mode 1~Mode 4	CLASS B	Pass	Site1
Note: 1, Measurement taken is within the measurement uncertainty of measurement system. 2, <input checked="" type="checkbox"/> The item has been tested; <input type="checkbox"/> The item has not been tested.				

During the measurement, the environmental conditions complied with the range listed as below.

Item	Required
Ambient temperature	15°C ~ 35°C
Relative humidity	25% ~ 75%
Atmospheric pressure	86kPa ~ 106kPa

### 3 System Configuration during EMC Test

#### 3.1 Test Mode

Huawei has verified the construction and function in typical operation. All the test modes are carried out with the EUT under normal operation, which are shown in this test report and defined as below:

Test Mode	
Mode 1:	EUT with Adapter+ USB Cable+ Idle Mode
Mode 2:	EUT with Adapter+ USB Cable+ Traffic Mode
Mode 3:	EUT with PC+ USB Cable+ Idle Mode
Mode 4:	EUT with PC+ USB Cable + Traffic Mode

Traffic Mode:

When the EUT state is switched on and with Radio Resource Control (RRC) connection established.

Idle Mode:

When the EUT state is switched on but without Radio Resource Control (RRC) connection.

#### 3.2 Test System Configuration

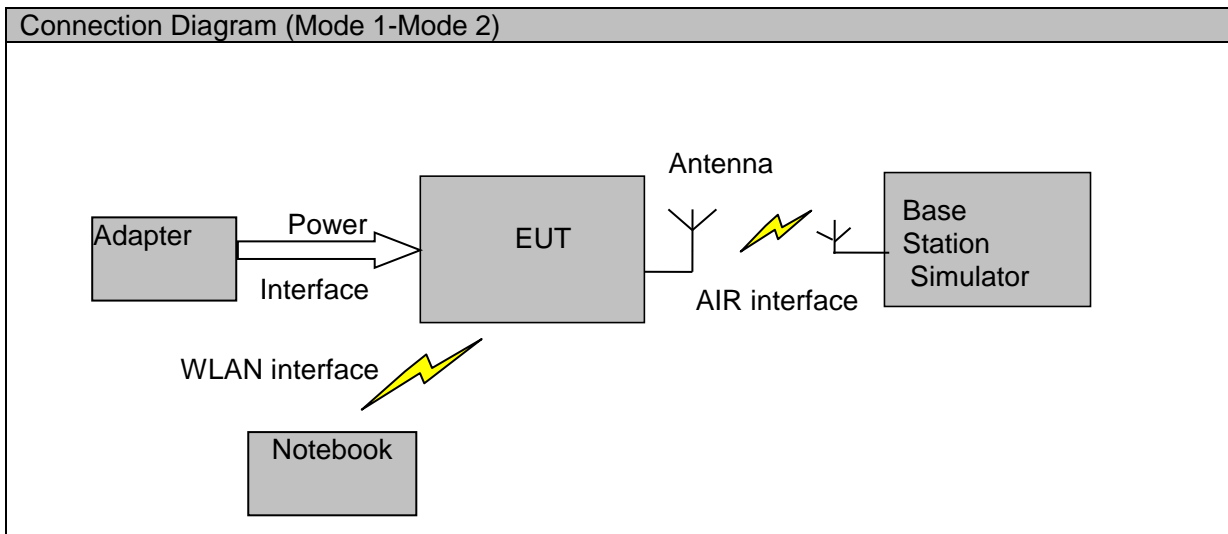



Connection Diagram (Mode 3~Mode 4)

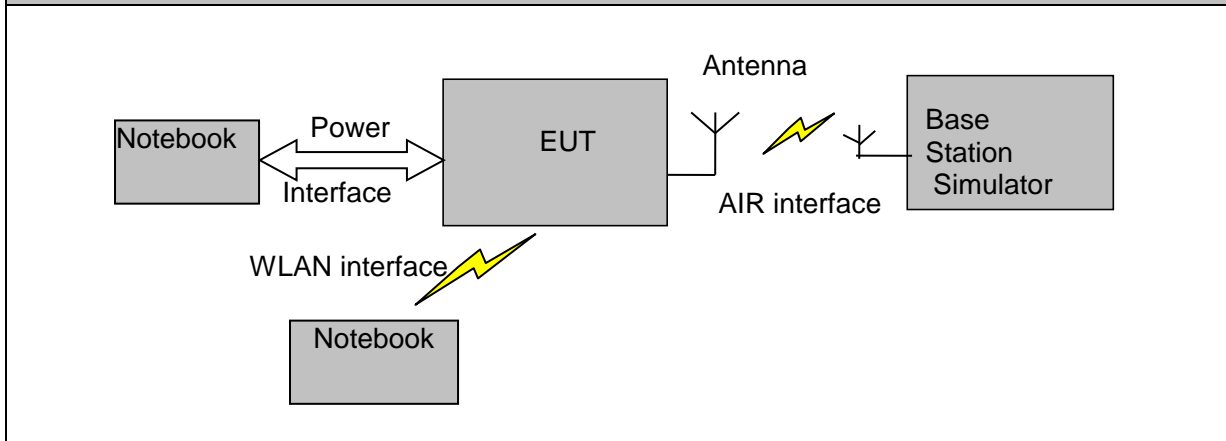

### 3.3 Cables Used during Test

Cable	Quantity	Length	Type of Cable
USB cable	1	1m	shielded

### 3.4 Associated Equipment Used during Test

Name	Model	Manufacturer	S/N	Calibrated Deadline	Cal interval (month)
Radio Communication Tester	CMU200	R&S	3608105673	2018-03-01	12
Radio Communication Tester	MT8820C	Anritsu	A110518805	2018-05-15	12
Notebook	X230	ThinkPad	31090403579	/	/
Notebook	X230	ThinkPad	31090403578	/	/
Mouse	N231	Logitech	/	/	/
Adaptor	HW-050200E01	HUAWEI	P78711FCL07584	/	/

## 4 Electromagnetic Interference (EMI)

### 4.1 Radiated Disturbance 30MHz to 18GHz

#### 4.1.1 Test Procedure

The test site semi-anechoic chamber has met the requirement of NSA tolerance 4dB according to the standards: ANSI C63.4-2014. The test distance is 3m. The set-up and test methods are according to ANSI C63.4-2014.

A preliminary scan and a final scan of the emissions are made from 30 MHz to 18 GHz by using test script of software; The emissions are measured using Quasi-Peak Detector (30MHz~1GHz) and AV/PK detector (above 1GHz). The maximal emission value is acquired by adjusting the antenna height, polarisation and turntable azimuth in accordance with the software setup. Normally, the height range of antenna is 1m to 4m. The azimuth range of turntable is 0° to 360°. The receiving antenna has two polarizations V and H.

Measurement bandwidth (RBW) for 30MHz to 1000 MHz: 120 kHz;

Measurement bandwidth (RBW) for 1000MHz to 18000 MHz: 1MHz;

EUT is configured in idle mode and the test performed at worst emission state.

#### 4.1.2 Test setup

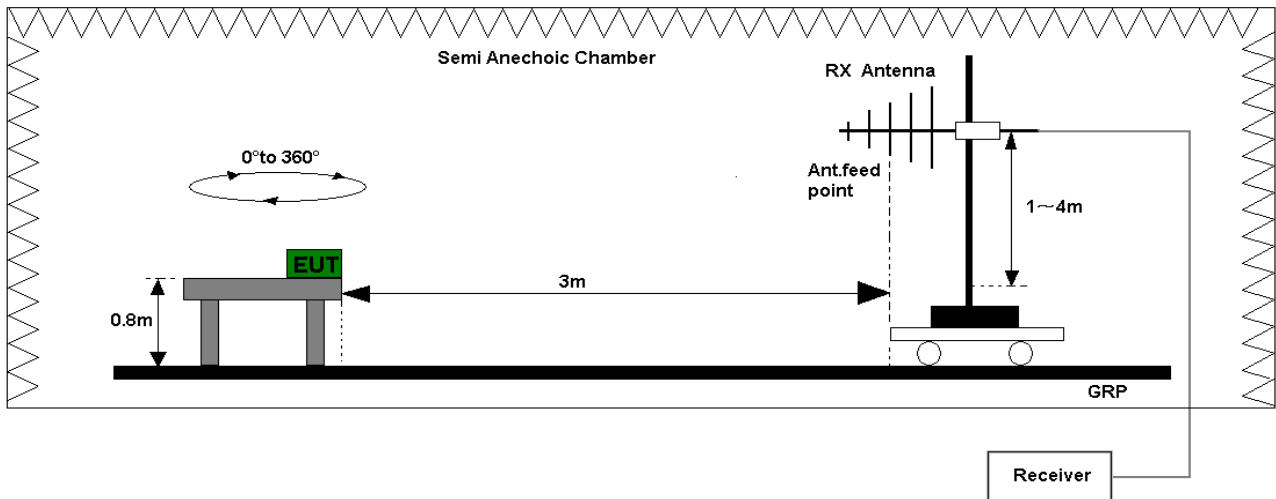

Figure 1. Test set-up of radiated disturbance(30MHz-1GHz )

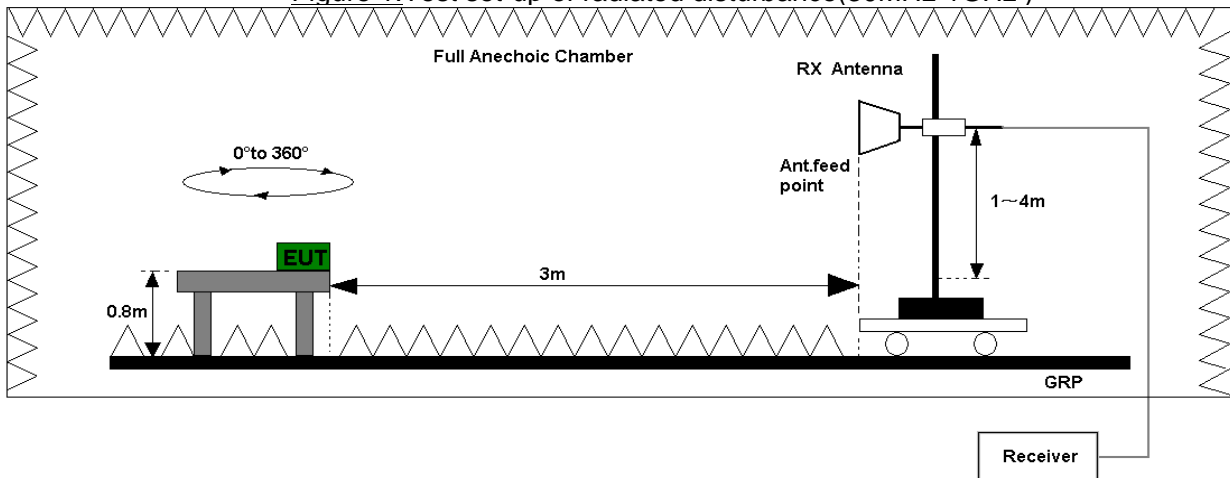

Figure 2. Test set-up of radiated disturbance(above 1GHz)



### 4.1.3 Test Results

The EUT has met the requirements for Radiated Emission of enclosure port.  
 Refer to the section 7.1 of this report for test data.

Test Limits (Class B)				
Frequency of Emission (MHz)	Radiated Limit			
	Unit( $\mu$ V/m)		Unit(dB $\mu$ V/m)	
30-88	100		40	
88-216	150		43.5	
216-960	200		46	
Above 960	500		54	
Above 1000	AV	PK	AV	PK
	500	5000	54	74

## 4.2 Conducted Disturbance 0.15 MHz to 30MHz

### 4.2.1 Test Procedure

The Table-top EUT is placed upon a non-metallic table 0.8 m above the horizontal metal reference ground plane. EUT is connected to LISN and LISN is connected to reference Ground Plane. EUT is 80cm away from LISN. The set-up and test methods are according to ANSI C63.4-2014.

Conducted Disturbance at AC Port measurements are undertaken on the L and N Lines. The emissions are measured using a Quasi-Peak Detector and Average Detector.

EUT is communicated with the simulator through Air interface, the simulator controls the EUT to transmitter the maximum power which defined in specification of product. The EUT operated on the typical channel.

Measurement bandwidth (RBW) for 150 kHz to 30 MHz: 9 kHz;

The EUT is set in the shielded chamber and operated under nominal conditions.

### 4.2.2 Test Setup

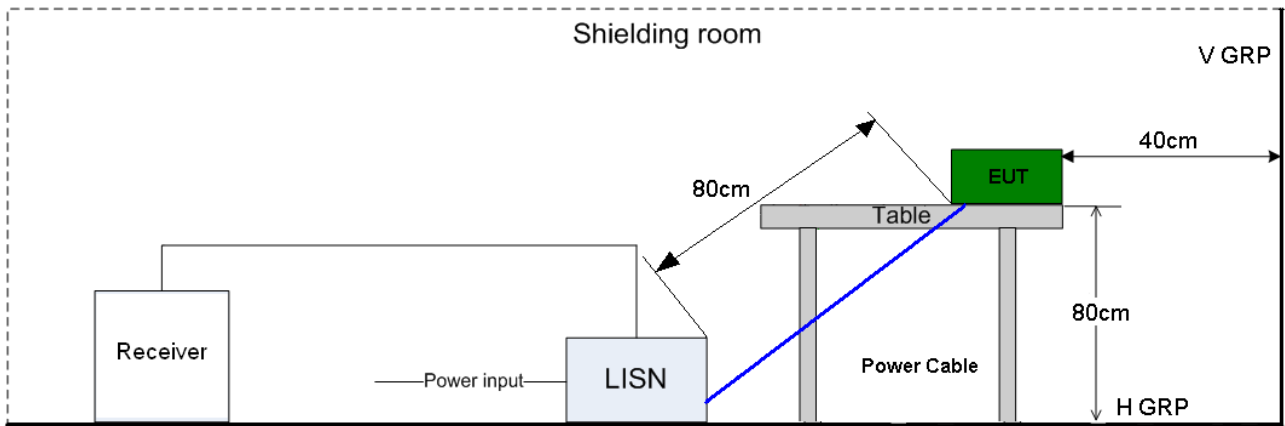

Figure 3. Test Set-up of conducted disturbance

### 4.2.3 Test Results

The EUT has met requirements for Conducted disturbance.

Refer to the section 7.2 of this report for test data.

Test Limit of AC Power Port		
Frequency range	150kHz ~ 30MHz	
Frequency	Voltage limits	
	QP	AV
0.15MHz~0.5MHz	66-56 dB $\mu$ V	56-46 dB $\mu$ V
0.5MHz-5MHz	56 dB $\mu$ V	46 dB $\mu$ V
5MHz~30MHz	60 dB $\mu$ V	50 dB $\mu$ V

## 5 Main Test Instruments

Main Test Equipments						
Test item	Test Instrument	Model	S/N	Manufacturer	Calibrated deadline	Cal interval (month)
RE	EMI Test receiver	ESU26	100150	R&S	Feb. 20, 2018	12
	Broadband Antenna	VULB 9163	9163-491	SCHWARZBECK	Mar. 28, 2019	24
	Horn Antenna	HF906	100683	R&S	Mar. 28, 2019	24
CE	EMI Test receiver	ESU26	101163	R&S	Feb. 20, 2018	12
	Artificial Mains Network	ENV216	100382	R&S	May. 15, 2018	12
Software Information						
Test Item	Software Name		Manufacturer		Version	
RE	EMC32		R&S		V9.25.0	
CE	EMC32		R&S		V9.25.0	



**6 System Measurement Uncertainty**

For a 95% confidence level, the measurement expanded uncertainties for defined systems, in accordance with the recommendations of ISO 17025 are:

<b>System Measurement Uncertainty</b>		
<b>Items</b>		<b>Extended Uncertainty</b>
RE(30MHz-1GHz)	Field strength (dB $\mu$ V/m)	U=4.1dB; k=2
RE(1GHz-18GHz)	Field strength (dB $\mu$ V/m)	U=5.0dB; k=2
CE	Disturbance Voltage (dB $\mu$ V)	U=2.5dB; k=2

## 7 Test Data and Graph

Only the worst test result is shown in this report.

### 7.1 Radiated Disturbance

#### 7.1.1 30MHz~1GHz

Mode 1:

Full Spectrum

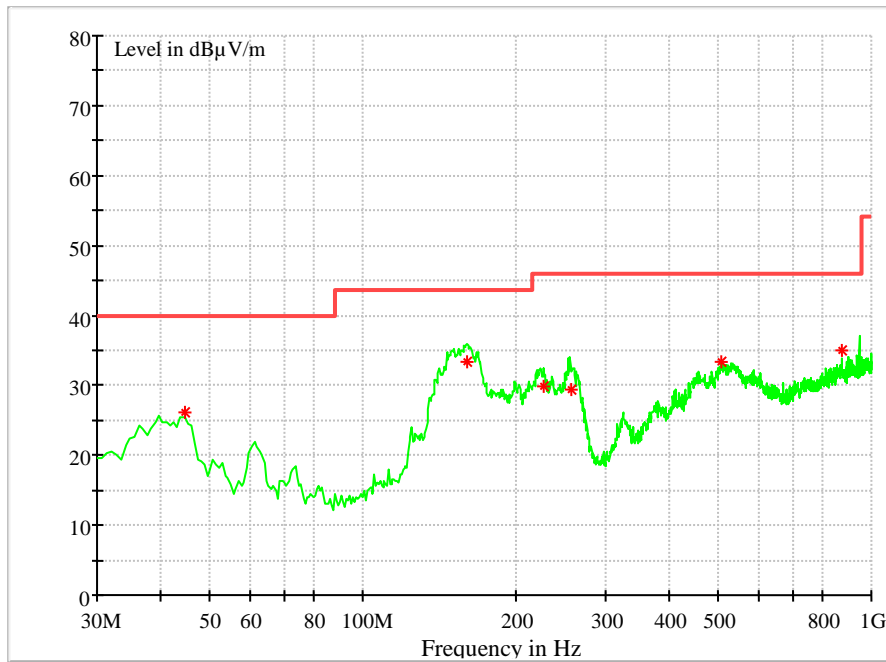

#### MEASUREMENT RESULT: QP Detector

Frequency MHz	Level dBµV/m	Transd dB	Limit dBµV/m	Margin dB	Height cm	Azimuth deg	Polarisation
44.788000	26.01	16.6	40.00	13.99	101.0	203.0	VERTICAL
160.423714	33.40	11.5	43.50	10.10	100.0	312.0	VERTICAL
225.965715	29.76	14.1	46.00	16.24	132.0	240.0	VERTICAL
256.726858	29.41	14.3	46.00	16.59	101.0	316.0	HORIZONTAL
506.048000	33.33	20.9	46.00	12.67	100.0	95.0	VERTICAL
876.624857	35.08	26.4	46.00	10.92	390.0	88.0	HORIZONTAL

Note:

Level = Reading level by receiver + Transd (Antenna factor + cable loss – preamplifier gain)

The reading level is calculated by software which is not shown in the sheet.

### 7.1.2 1GHz~18GHz

Mode 1:

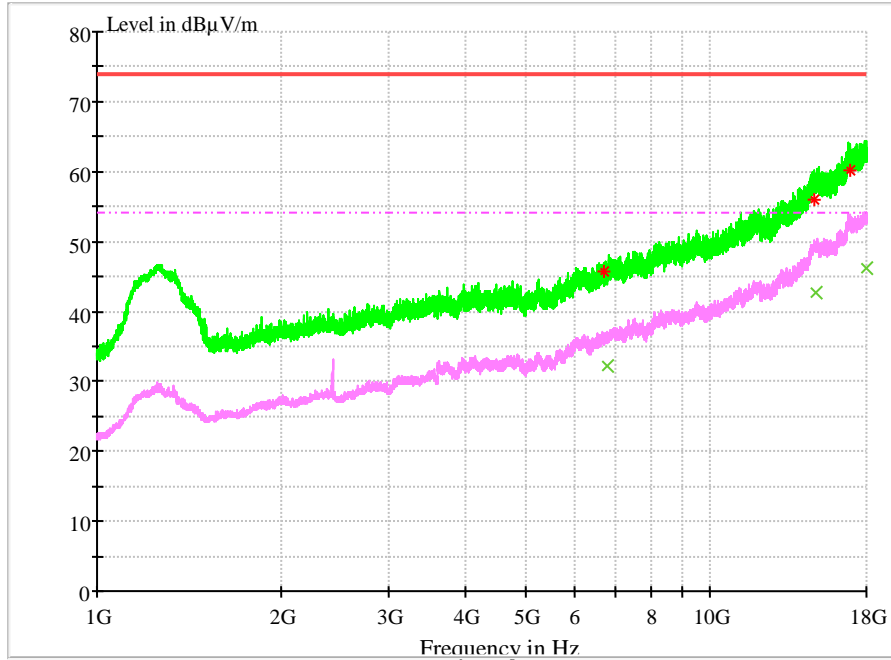

#### MEASUREMENT RESULT: PK Detector

Frequency MHz	Level dBµV/m	Transd dB	Limit dBµV/m	Margin dB	Height cm	Azimuth deg	Polarisation
6709.045334	45.8	2.8	74	28.2	188	82	VERTICAL
14761.35667	55.99	17.5	74	18.01	185	144	HORIZONTAL
16913.83867	60.06	20.9	74	13.94	150	94	HORIZONTAL

#### MEASUREMENT RESULT: AV Detector

Frequency MHz	Level dBµV/m	Transd dB	Limit dBµV/m	Margin dB	Height cm	Azimuth deg	Polarisation
6793.51	32.23	3	54	21.77	273	328	VERTICAL
14885.196	42.69	17.6	54	11.31	185	4	HORIZONTAL
17976.288	46.2	21.2	54	7.8	200	58	HORIZONTAL

Note:

Level = Reading level by receiver + Transd (Antenna factor + cable loss – preamplifier gain)  
The reading level is calculated by software which is not shown in the sheet.



## 7.2 Conducted Disturbance

### 7.2.1 AC Port Test Data

Mode 2:

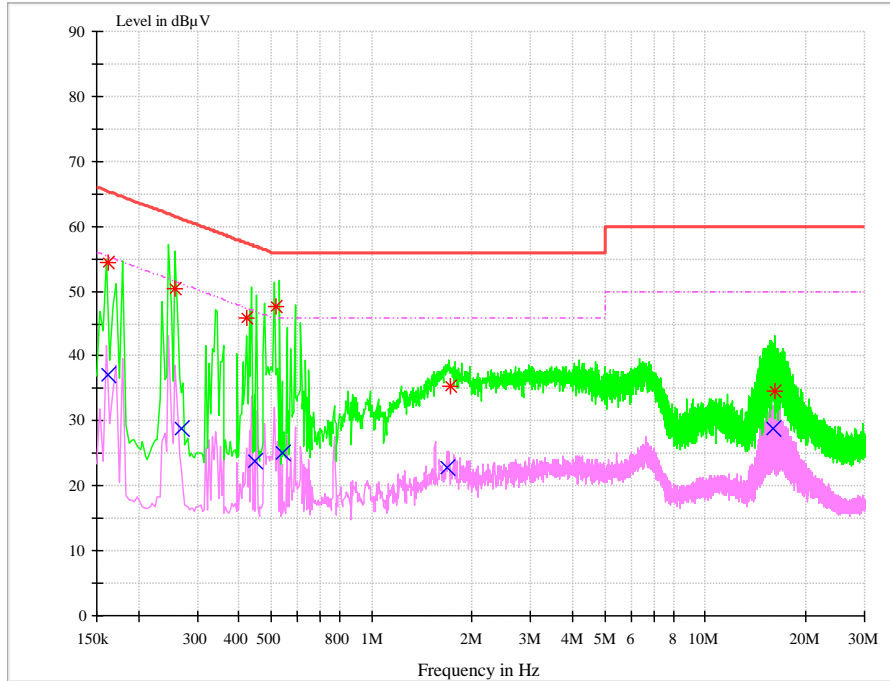

#### MEASUREMENT RESULT: QP Detector

Frequency MHz	Level dBµV	Line	Transd dB	Margin dB	Limit dBµV	PE
0.161422	54.42	L1	9.7	10.97	65.39	FLO
0.257002	50.42	N	9.7	11.11	61.53	FLO
0.423806	45.91	L1	9.7	11.46	57.37	FLO
0.515783	47.63	N	9.7	8.37	56	FLO
1.716686	35.33	L1	9.7	20.67	56	FLO
16.247925	34.54	L1	10.1	25.46	60	FLO

#### MEASUREMENT RESULT: AV Detector

Frequency MHz	Level dBµV	Line	Transd dB	Margin dB	Limit dBµV	PE
0.161658	37.02	L1	9.7	18.36	55.38	FLO
0.268927	28.82	L1	9.7	22.33	51.15	FLO
0.447701	23.77	L1	9.7	23.14	46.91	FLO
0.539093	25.08	L1	9.7	20.92	46	FLO
1.693901	22.85	L1	9.7	23.15	46	FLO
15.909675	28.78	L1	10.1	21.22	50	FLO

Note:

Level= Reading level+ Transd (cable loss + correction factor)

The reading level is calculated by software which is not shown in the sheet.

-----END-----