



FCC RF Test Report

APPLICANT : Huawei Technologies Co.,Ltd.
EQUIPMENT : Huawei Mediapad M5 wp
BRAND NAME : HUAWEI
MODEL NAME : d-02K
FCC ID : QISHDL-L0J
STANDARD : 47 CFR Part 2, 22(H)
CLASSIFICATION : PCS Licensed Transmitter worn on body (PCT)

The product was received on Apr. 04, 2018 and completely tested on Apr. 27, 2018. We, Sporton International (Kunshan) Inc., would like to declare that the tested sample has been evaluated in accordance with the procedures given in ANSI C63.26-2015 and shown compliance with the applicable technical standards.

The test results in this report apply exclusively to the tested model / sample. Without written approval of Sporton International (Kunshan) Inc., the test report shall not be reproduced except in full.

Approved by: James Huang / Manager



Sporton International (Kunshan) Inc.

No.3-2 Ping-Xiang Rd, Kunshan Development Zone Kunshan City Jiangsu Province 215335 China



TABLE OF CONTENTS

REVISION HISTORY.....3
SUMMARY OF TEST RESULT4
1 GENERAL DESCRIPTION5
1.1 Applicant.....5
1.2 Manufacturer.....5
1.3 Product Feature of Equipment Under Test.....5
1.4 Product Specification of Equipment Under Test.....5
1.5 Modification of EUT6
1.6 Maximum ERP Power, Frequency Tolerance, and Emission Designator6
1.7 Testing Location7
1.8 Applicable Standards.....7
2 TEST CONFIGURATION OF EQUIPMENT UNDER TEST8
2.1 Test Mode.....8
2.2 Connection Diagram of Test System.....9
2.3 Support Unit used in test configuration and system9
2.4 Measurement Results Explanation Example.....9
2.5 Frequency List of Low/Middle/High Channels10
3 CONDUCTED TEST ITEMS11
3.1 Measuring Instruments11
3.2 Test Setup11
3.3 Test Result of Conducted Test11
3.4 Conducted Output Power and ERP12
3.5 Peak-to-Average Ratio13
3.6 Occupied Bandwidth.....14
3.7 Conducted Band Edge15
3.8 Conducted Spurious Emission16
3.9 Frequency Stability17
4 RADIATED TEST ITEMS18
4.1 Measuring Instruments18
4.2 Test Setup18
4.3 Test Result of Radiated Test18
4.4 Radiated Spurious Emission19
5 LIST OF MEASURING EQUIPMENT20
6 UNCERTAINTY OF EVALUATION21
APPENDIX A. TEST RESULTS OF CONDUCTED TEST
APPENDIX B. TEST RESULTS OF RADIATED TEST
APPENDIX C. TEST SETUP PHOTOGRAPHS



SUMMARY OF TEST RESULT

Report Section	FCC Rule	Description	Limit	Result	Remark
3.4	§2.1046	Conducted Output Power	Reporting Only	PASS	-
	§22.913(a)(5)	Effective Radiated Power (Band 5) (Band 26)	ERP < 7 Watt	PASS	-
3.5	N/A	Peak-to-Average Ratio	<13 dB	PASS	-
3.6	§2.1049	Occupied Bandwidth	Reporting Only	PASS	-
3.7	§2.1051 §22.917(a)	Conducted Band Edge Measurement (Band 5)	< 43+10log ₁₀ (P[Watts])	PASS	-
3.8	§2.1051 §22.917(a)	Conducted Spurious Emission (Band 5)	< 43+10log ₁₀ (P[Watts])	PASS	-
3.9	§2.1055 §22.355	Frequency Stability Temperature & Voltage	< 2.5 ppm for Part 22	PASS	-
4.4	§2.1053 §22.917(a)	Radiated Spurious Emission (Band 5)	< 43+10log ₁₀ (P[Watts])	PASS	Under limit 27.75 dB at 2496.000 MHz



1 General Description

1.1 Applicant

Huawei Technologies Co.,Ltd.

Administration Building, Headquarters of Huawei Technologies Co., Ltd., Bantian, Longgang District, Shenzhen, 518129, P.R.C

1.2 Manufacturer

Huawei Technologies Co.,Ltd.

Administration Building, Headquarters of Huawei Technologies Co., Ltd., Bantian, Longgang District, Shenzhen, 518129, P.R.C

1.3 Product Feature of Equipment Under Test

Product Feature	
Equipment	Huawei Mediapad M5 wp
Brand Name	HUAWEI
Model Name	d-02K
FCC ID	QISHDL-L0J
EUT supports Radios application	WCDMA/HSDPA/HSUPA B5 LTE B5 WLAN 2.4GHz 802.11b/g/n HT20/HT40 WLAN 5GHz 802.11a/n HT20/HT40 WLAN 5GHz 802.11ac VHT20/VHT40/VHT80 Bluetooth v2.1+EDR/Bluetooth v 4.2 LE
IMEI Code	Conducted: 867555030008903 Radiation: 867555030008713
HW Version	SH1HDLAL09M
SW Version	18032602

1.4 Product Specification of Equipment Under Test

Standards-related Product Specification	
Tx Frequency	LTE Band 5 : 824.7 MHz ~ 848.3 MHz
Rx Frequency	LTE Band 5 : 869.7 MHz ~ 893.3 MHz
Bandwidth	LTE Band 5 : 1.4MHz / 3MHz / 5MHz / 10MHz
Maximum Output Power to Antenna	LTE Band 5 : 23.11 dBm
Antenna Gain	LTE Band 5 : 1.0 dBi
Type of Modulation	QPSK / 16QAM



1.5 Modification of EUT

No modifications are made to the EUT during all test items.

1.6 Maximum ERP Power, Frequency Tolerance, and Emission Designator

LTE Band 5		QPSK			16QAM		
BW (MHz)	Frequency Range (MHz)	Emission Designator (99%OBW)	Frequency Tolerance (ppm)	Maximum ERP(W)	Emission Designator (99%OBW)	Frequency Tolerance (ppm)	Maximum ERP(W)
1.4	824.7 ~ 848.3	1M10G7D	-	0.1489	1M10W7D	-	0.1242
3	825.5 ~ 847.5	2M73G7D	-	0.1466	2M73W7D	-	0.1265
5	826.5 ~ 846.5	4M50G7D	-	0.1507	4M50W7D	-	0.1349
10	829.0 ~ 844.0	9M03G7D	0.0061	0.1570	9M05W7D	-	0.1330



1.7 Testing Location

Sporton International (Kunshan) Inc. is accredited to ISO 17025 by National Voluntary Laboratory Accreditation Program (NVLAP code: 600155-0) and the FCC designation No is CN5013.

Test Site	Sporton International (Kunshan) Inc.		
Test Site Location	No.3-2 Ping-Xiang Rd, Kunshan Development Zone Kunshan City Jiangsu Province 215335 China TEL : +86-512-57900158 FAX : +86-512-57900958		
Test Site No.	Sporton Site No.		FCC Test Firm Registration No.
	TH01-KS	03CH03-KS	630927

Note: The test site complies with ANSI C63.4 2014 requirement.

1.8 Applicable Standards

According to the specifications of the manufacturer, the EUT must comply with the requirements of the following standards:

- ♦ 47 CFR Part 2, 22(H)
- ♦ ANSI C63.26-2015
- ♦ FCC KDB 971168 D01 Power Meas License Digital Systems v03r01
- ♦ FCC KDB 412172 D01 Determining ERP and EIRP v01r01

Remark:

1. All test items were verified and recorded according to the standards and without any deviation during the test.
2. This EUT has also been tested and complied with the requirements of FCC Part 15, Subpart B, recorded in a separate test report.



2 Test Configuration of Equipment Under Test

2.1 Test Mode

Antenna port conducted and radiated test items listed below are performed according to KDB 971168 D01 Power Meas License Digital Systems v03r01 with maximum output power.

Radiated measurements are performed by rotating the EUT in three different orthogonal test planes to find the maximum emission.

Test Items	Band	Bandwidth (MHz)						Modulation			RB #			Test Channel		
		1.4	3	5	10	15	20	QPSK	16QAM	64QAM	1	Half	Full	L	M	H
Max. Output Power	5	v	v	v	v	-	-	v	v		v	v	v	v	v	v
Peak-to-Average Ratio	5				v	-	-	v	v		v		v	v	v	v
26dB and 99% Bandwidth	5	v	v	v	v	-	-	v	v				v	v	v	v
Conducted Band Edge	5	v	v	v	v	-	-	v	v		v		v	v		v
Conducted Spurious Emission	5	v	v	v	v	-	-	v	v		v			v	v	v
Frequency Stability	5				v	-	-	v					v		v	
E.R.P.	5	v	v	v	v	-	-	v	v		v			v	v	v
Radiated Spurious Emission	5	Worst Case													v	
Note	<ol style="list-style-type: none"> The mark "v" means that this configuration is chosen for testing The mark "-" means that this bandwidth is not supported. The device is investigated from 30MHz to 10 times of fundamental signal for radiated spurious emission test under different RB size/offset and modulations in exploratory test. Subsequently, only the worst case emissions are reported. 															

2.2 Connection Diagram of Test System

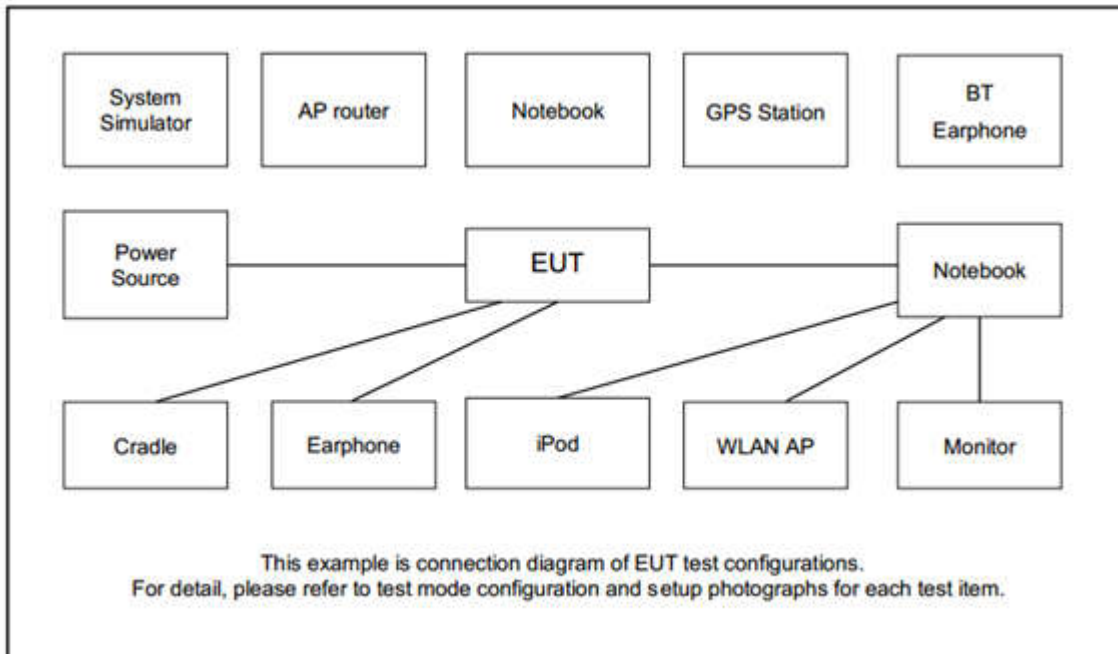

2.3 Support Unit used in test configuration and system

Item	Equipment	Trade Name	Model No.	FCC ID	Data Cable	Power Cord
1.	DC Power Supply	GW	GPS-3030D	N/A	N/A	Unshielded, 1.8 m
2.	LTE Base Station	Anritsu	MT8820C	N/A	N/A	Unshielded, 1.8 m

2.4 Measurement Results Explanation Example

For all conducted test items:

The offset level is set in the spectrum analyzer to compensate the RF cable loss between EUT conducted output port and spectrum analyzer. With the offset compensation, the spectrum analyzer reading level is exactly the EUT RF output level.

The spectrum analyzer offset is derived from RF cable loss.

Offset = RF cable loss.

Following shows an offset computation example with cable loss 4.4 dB.

Example :

$$\begin{aligned} \text{Offset(dB)} &= \text{RF cable loss(dB)}. \\ &= 4.4 \text{ (dB)} \end{aligned}$$



2.5 Frequency List of Low/Middle/High Channels

LTE Band 5 Channel and Frequency List				
BW [MHz]	Channel/Frequency(MHz)	Lowest	Middle	Highest
10	Channel	20450	20525	20600
	Frequency	829	836.5	844
5	Channel	20425	20525	20625
	Frequency	826.5	836.5	846.5
3	Channel	20415	20525	20635
	Frequency	825.5	836.5	847.5
1.4	Channel	20407	20525	20643
	Frequency	824.7	836.5	848.3

3 Conducted Test Items

3.1 Measuring Instruments

See list of measuring instruments of this test report.

3.2 Test Setup

3.2.1 Conducted Output Power



3.2.2 Peak-to-Average Ratio, Occupied Bandwidth ,Conducted Band-Edge and Conducted Spurious Emission

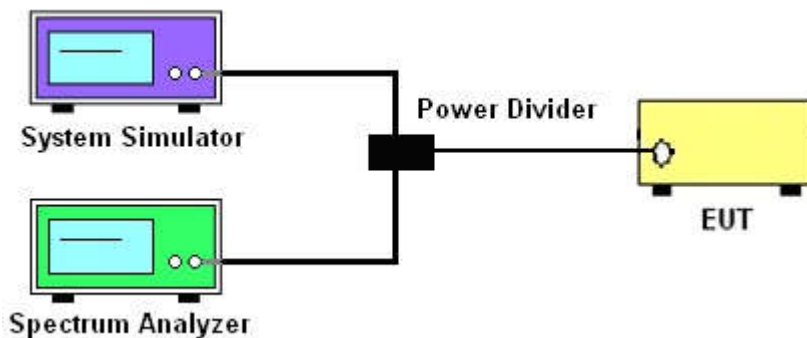

3.2.3 Frequency Stability

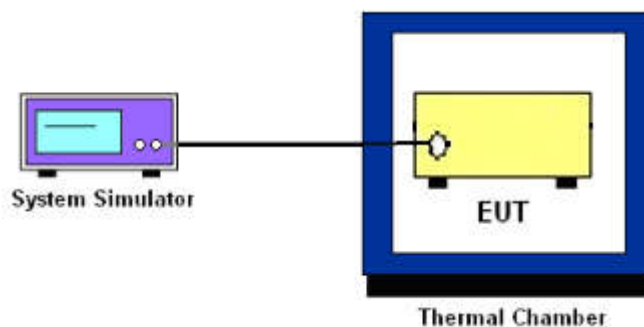

3.3 Test Result of Conducted Test

Please refer to Appendix A.



3.4 Conducted Output Power and ERP

3.4.1 Description of the Conducted Output Power Measurement and ERP Measurement

A system simulator was used to establish communication with the EUT. Its parameters were set to force the EUT transmitting at maximum output power. The measured power in the radio frequency on the transmitter output terminals shall be reported.

The ERP of mobile transmitters must not exceed 7 Watts for LTE Band 5.

According to KDB 412172 D01 Power Approach,

$EIRP = P_T + G_T - L_C$, $ERP = EIRP - 2.15$, where

P_T = transmitter output power in dBm

G_T = gain of the transmitting antenna in dBi

L_C = signal attenuation in the connecting cable between the transmitter and antenna in dB

3.4.2 Test Procedures

1. The testing follows ANSI C63.26 Section 5.2
2. The transmitter output port was connected to the system simulator.
3. Set EUT at maximum power through the system simulator.
4. Select lowest, middle, and highest channels for each band and different modulation.
5. Measure and record the power level from the system simulator.



3.5 Peak-to-Average Ratio

3.5.1 Description of the PAR Measurement

Power Complementary Cumulative Distribution Function (CCDF) curves provide a means for characterizing the power peaks of a digitally modulated signal on a statistical basis. A CCDF curve depicts the probability of the peak signal amplitude exceeding the average power level. Most contemporary measurement instrumentation include the capability to produce CCDF curves for an input signal provided that the instrument's resolution bandwidth can be set wide enough to accommodate the entire input signal bandwidth. In measuring transmissions in this band using an average power technique, the peak-to-average ratio (PAR) of the transmission may not exceed 13 dB.

3.5.2 Test Procedures

1. The testing follows ANSI C63.26 Section 5.2.3.4 (CCDF).
2. The EUT was connected to spectrum and system simulator via a power divider.
3. Set the CCDF (Complementary Cumulative Distribution Function) option in spectrum analyzer.
4. The highest RF powers were measured and recorded the maximum PAPR level associated with a probability of 0.1 %.
5. Record the deviation as Peak to Average Ratio.



3.6 Occupied Bandwidth

3.6.1 Description of Occupied Bandwidth Measurement

The occupied bandwidth is the width of a frequency band such that, below the lower and above the upper frequency limits, the mean powers emitted are each equal to a specified percentage 0.5% of the total mean transmitted power.

The 26 dB emission bandwidth is defined as the frequency range between two points, one above and one below the carrier frequency, at which the spectral density of the emission is attenuated 26 dB below the maximum in-band spectral density of the modulated signal. Spectral density (power per unit bandwidth) is to be measured with a detector of resolution bandwidth equal to approximately 1.0% of the emission bandwidth.

3.6.2 Test Procedures

1. The testing follows ANSI C63.26 Section 5.4
2. The EUT was connected to spectrum analyzer and system simulator via a power divider.
3. The spectrum analyzer center frequency is set to the nominal EUT channel center frequency. The span range for the spectrum analyzer shall be between two and five times the anticipated OBW.
4. The nominal resolution bandwidth (RBW) shall be in the range of 1 to 5 % of the anticipated OBW, and the VBW shall be at least 3 times the RBW.
5. Set the detection mode to peak, and the trace mode to max hold.
6. Determine the reference value: Set the EUT to transmit a modulated signal. Allow the trace to stabilize. Set the spectrum analyzer marker to the highest level of the displayed trace.
(this is the reference value)
7. Determine the “-26 dB down amplitude” as equal to (Reference Value – X).
8. Place two markers, one at the lowest and the other at the highest frequency of the envelope of the spectral display such that each marker is at or slightly below the “-X dB down amplitude” determined in step 6. If a marker is below this “-X dB down amplitude” value it shall be placed as close as possible to this value. The OBW is the positive frequency difference between the two markers.
9. Use the 99 % power bandwidth function of the spectrum analyzer and report the measured bandwidth.



3.7 Conducted Band Edge

3.7.1 Description of Conducted Band Edge Measurement

22.917(a)

For operations in the 824 – 849 MHz band, the FCC limit is $43 + 10\log_{10}(P[\text{Watts}])$ dB below the transmitter power P(Watts) in a 100kHz bandwidth. However, in the 1MHz bands immediately outside and adjacent to the licensee's frequency block, a resolution bandwidth of at least one percent of the emission bandwidth of the fundamental emission of the transmitter may be employed.

3.7.2 Test Procedures

1. The testing follows ANSI C63.26 section 5.7
2. The EUT was connected to spectrum analyzer and system simulator via a power divider.
3. The band edges of low and high channels for the highest RF powers were measured.
4. Set RBW $\geq 1\%$ EBW in the 1MHz band immediately outside and adjacent to the band edge.
5. Beyond the 1 MHz band from the band edge, RBW=1MHz was used.
6. Set spectrum analyzer with RMS detector.
7. The RF fundamental frequency should be excluded against the limit line in the operating frequency band.
8. Checked that all the results comply with the emission limit line.

Example:

The limit line is derived from $43 + 10\log(P)$ dB below the transmitter power P(Watts)
= P(W)- [43 + 10log(P)] (dB)
= [30 + 10log(P)] (dBm) - [43 + 10log(P)] (dB) = -13dBm.



3.8 Conducted Spurious Emission

3.8.1 Description of Conducted Spurious Emission Measurement

The power of any emission outside of the authorized operating frequency ranges must be lower than the transmitter power (P) by a factor of at least $43 + 10 \log (P)$ dB.

It is measured by means of a calibrated spectrum analyzer and scanned from 30 MHz up to a frequency including its 10th harmonic.

3.8.2 Test Procedures

1. The testing follows ANSI C63.26 section 5.7
2. The EUT was connected to spectrum analyzer and system simulator via a power divider.
3. The RF output of EUT was connected to the spectrum analyzer by RF cable and attenuator. The path loss was compensated to the results for each measurement.
4. The middle channel for the highest RF power within the transmitting frequency was measured.
5. The conducted spurious emission for the whole frequency range was taken.
6. Make the measurement with the spectrum analyzer's RBW = 1MHz, VBW = 3MHz.
7. Set spectrum analyzer with RMS detector.
8. Taking the record of maximum spurious emission.
9. The RF fundamental frequency should be excluded against the limit line in the operating frequency band.
10. The limit line is derived from $43 + 10\log(P)$ dB below the transmitter power P(Watts)
= P(W)- [43 + 10log(P)] (dB)
= [30 + 10log(P)] (dBm) - [43 + 10log(P)] (dB)
= -13dBm.



3.9 Frequency Stability

3.9.1 Description of Frequency Stability Measurement

The frequency stability shall be measured by variation of ambient temperature and variation of primary supply voltage to ensure that the fundamental emission stays within the authorized frequency block. The frequency stability of the transmitter shall be maintained within $\pm 0.00025\%$ ($\pm 2.5\text{ppm}$) of the center frequency.

3.9.2 Test Procedures for Temperature Variation

1. The testing follows ANSI C63.26 section 5.6.4
2. The EUT was set up in the thermal chamber and connected with the system simulator.
3. With power OFF, the temperature was decreased to -30°C and the EUT was stabilized before testing. Power was applied and the maximum change in frequency was recorded within one minute.
4. With power OFF, the temperature was raised in 10°C step up to 50°C . The EUT was stabilized at each step for at least half an hour. Power was applied and the maximum frequency change was recorded within one minute.

3.9.3 Test Procedures for Voltage Variation

1. The testing follows ANSI C63.26 section 5.6.5
2. The EUT was placed in a temperature chamber at $20\pm 5^{\circ}\text{C}$ and connected with the system simulator.
3. The power supply voltage to the EUT was varied from 85% to 115% of the nominal value for other than hand carried battery equipment.
4. For hand carried, battery powered equipment, reduce the primary ac or dc supply voltage to the battery operating end point, which shall be specified by the manufacturer.
5. The variation in frequency was measured for the worst case.

4 Radiated Test Items

4.1 Measuring Instruments

See list of measuring instruments of this test report.

4.2 Test Setup

4.2.1 For radiated test from 30MHz to 1GHz

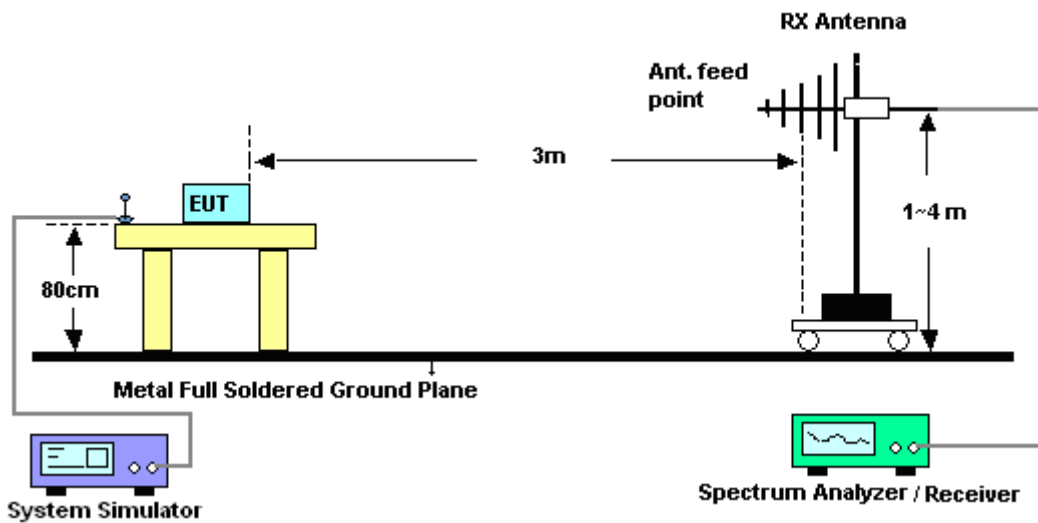

4.2.2 For radiated test above 1GHz

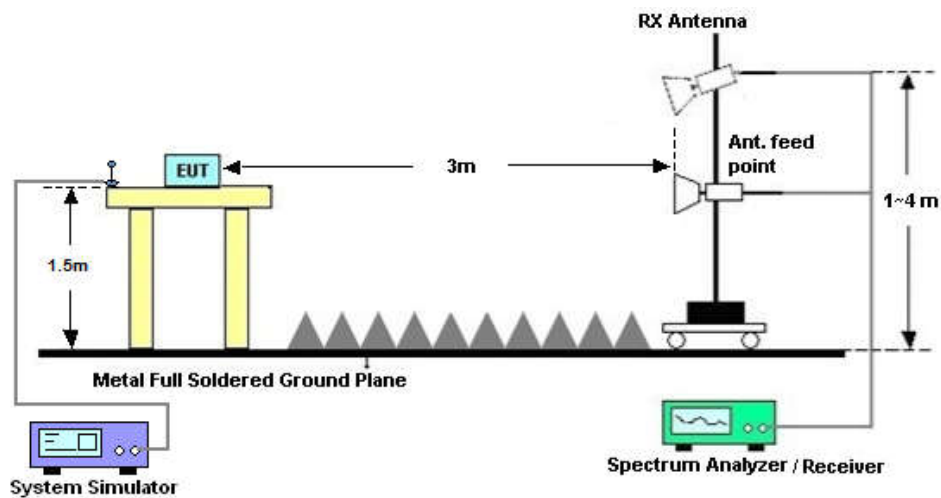

4.3 Test Result of Radiated Test

Please refer to Appendix B.



4.4 Radiated Spurious Emission

4.4.1 Description of Radiated Spurious Emission

The radiated spurious emission was measured by substitution method according to ANSI C63.26. The power of any emission outside of the authorized operating frequency ranges must be attenuated below the transmitter power (P) by a factor of at least $43 + 10 \log (P)$ dB.

The spectrum is scanned from 30 MHz up to a frequency including its 10th harmonic.

4.4.2 Test Procedures

1. The testing follows ANSI C63.26 Section 5.5
2. The EUT was placed on a turntable with 0.8 meter height for frequency below 1GHz and 1.5 meter height for frequency above 1GHz respectively above ground.
3. The EUT was set 3 meters from the receiving antenna mounted on the antenna tower.
4. The table was rotated 360 degrees to determine the position of the highest spurious emission.
5. The height of the receiving antenna is varied between 1m to 4m to search the maximum spurious emission for both horizontal and vertical polarizations.
6. During the measurement, the system simulator parameters were set to force the EUT transmitting at maximum output power.
7. Make the measurement with the spectrum analyzer's RBW = 1MHz, VBW = 3MHz, taking the record of maximum spurious emission.
8. A horn antenna was substituted in place of the EUT and was driven by a signal generator.
9. Tune the output power of signal generator to the same emission level with EUT maximum spurious emission.
10. $EIRP \text{ (dBm)} = S.G. \text{ Power} - Tx \text{ Cable Loss} + Tx \text{ Antenna Gain}$
11. $ERP \text{ (dBm)} = EIRP - 2.15$
12. The RF fundamental frequency should be excluded against the limit line in the operating frequency band.

The limit line is derived from $43 + 10\log(P)$ dB below the transmitter power P(Watts)
= $P(W) - [43 + 10\log(P)] \text{ (dB)}$
= $[30 + 10\log(P)] \text{ (dBm)} - [43 + 10\log(P)] \text{ (dB)}$
= -13dBm.



5 List of Measuring Equipment

Instrument	Manufacturer	Model No.	Serial No.	Characteristics	Calibration Date	Test Date	Due Date	Remark
Spectrum Analyzer	R&S	FSV40	101040	10Hz~40GHz	Aug. 08, 2017	Apr. 16, 2018	Aug. 07, 2018	Conducted (TH01-KS)
Radio communication analyzer	Anritsu	MT8820C	6201300652	2G/3G/LTE_ full band	Aug. 08, 2017	Apr. 16, 2018	Aug. 07, 2018	Conducted (TH01-KS)
Thermal Chamber	Ten Billion	TTC-B3S	TBN-960502	-40~+150°C	Oct. 12, 2017	Apr. 16, 2018	Oct. 11, 2018	Conducted (TH01-KS)
EXA Spectrum Analyzer	Keysight	N9010A	MY55150244	10Hz-44GHz	Apr. 17, 2018	Apr. 27, 2018	Apr.16, 2019	Radiation (03CH03-KS)
Bilog Antenna	TeseQ	CBL6112D	47610	30MHz-1GHz	Sep. 12, 2017	Apr. 27, 2018	Sep. 11, 2018	Radiation (03CH03-KS)
Double Ridge Horn Antenna	ETS-Lindgren	3117	75959	1GHz~18GHz	Jan. 21, 2018	Apr. 27, 2018	Jan. 20, 2019	Radiation (03CH03-KS)
SHF-EHF Horn	Schwarzbeck	BBHA 9170	BBHA170249	15GHz~40GHz	Feb. 07, 2018	Apr. 27, 2018	Feb. 06, 2019	Radiation (03CH03-KS)
Amplifier	com-power	PA-103A	161069	1MHz ~1000MHz / 32 dB	Apr. 17, 2018	Apr. 27, 2018	Apr.16, 2019	Radiation (03CH03-KS)
Amplifier	MITEQ	TTA1840-35-HG	1887435	18~40GHz	Oct. 12, 2017	Apr. 27, 2018	Oct. 11, 2018	Radiation (03CH03-KS)
high gain Amplifier	MITEQ	AMF-7D-00 101800-30-1 dB	2025788	1Ghz-18Ghz	Apr. 17, 2018	Apr. 27, 2018	Apr.16, 2019	Radiation (03CH03-KS)
Amplifier	Agilent	8449B	3008A02370	1GHz~26.5GHz	Oct. 12, 2017	Apr. 27, 2018	Oct. 11, 2018	Radiation (03CH03-KS)
AC Power Source	Chroma	61601	F104090004	N/A	NCR	Apr. 27, 2018	NCR	Radiation (03CH03-KS)
Turn Table	ChamPro	EM 1000-T	060762-T	0~360 degree	NCR	Apr. 27, 2018	NCR	Radiation (03CH03-KS)
Antenna Mast	ChamPro	EM 1000-A	060762-A	1 m~4 m	NCR	Apr. 27, 2018	NCR	Radiation (03CH03-KS)

NCR: No Calibration Required



6 Uncertainty of Evaluation

Uncertainty of Radiated Emission Measurement (30 MHz ~ 1000 MHz)

Measuring Uncertainty for a Level of Confidence of 95% ($U = 2Uc(y)$)	3.3dB
---	-------

Uncertainty of Radiated Emission Measurement (1 GHz ~ 18 GHz)

Measuring Uncertainty for a Level of Confidence of 95% ($U = 2Uc(y)$)	2.8dB
---	-------

Uncertainty of Radiated Emission Measurement (18 GHz ~ 40 GHz)

Measuring Uncertainty for a Level of Confidence of 95% ($U = 2Uc(y)$)	3.0dB
---	-------



Appendix A. Test Results of Conducted Test

Conducted Output Power(Average power)

LTE Band 5 Maximum Average Power [dBm]						
BW [MHz]	RB Size	RB Offset	Mod	Lowest	Middle	Highest
10	1	0	QPSK	22.06	22.69	22.07
10	1	25		23.09	22.71	23.11
10	1	49		22.47	22.04	22.30
10	25	0		21.75	21.53	21.78
10	25	12		22.14	22.06	22.15
10	25	25		22.11	21.50	22.14
10	50	0		21.94	21.81	22.00
10	1	0	16-QAM	21.35	22.03	21.41
10	1	25		22.39	22.14	22.32
10	1	49		21.77	21.39	21.65
10	25	0		20.69	20.99	20.83
10	25	12		21.10	20.99	21.21
10	25	25		21.05	20.57	21.21
10	50	0		20.88	20.81	21.05
5	1	0	QPSK	22.07	22.28	22.41
5	1	12		22.44	22.41	22.93
5	1	24		22.13	22.09	22.04
5	12	0		21.14	21.55	21.97
5	12	7		21.49	21.50	22.13
5	12	13		21.45	21.21	21.80
5	25	0		21.30	21.43	21.86
5	1	0	16-QAM	21.52	21.63	21.81
5	1	12		21.79	21.78	22.45
5	1	24		21.50	21.44	21.48
5	12	0		20.10	20.50	21.02
5	12	7		20.46	20.45	21.21
5	12	13		20.46	20.19	20.90
5	25	0		20.26	20.38	20.94



LTE Band 5 Maximum Average Power [dBm]						
BW [MHz]	RB Size	RB Offset	Mod	Lowest	Middle	Highest
3	1	0	QPSK	22.02	22.29	22.81
3	1	8		22.06	22.34	22.75
3	1	14		22.07	22.04	22.16
3	8	0		21.07	21.53	22.07
3	8	4		21.28	21.49	22.00
3	8	7		21.31	21.33	21.78
3	15	0		21.18	21.42	21.91
3	1	0	16-QAM	21.03	21.58	22.14
3	1	8		21.45	21.71	22.17
3	1	14		21.35	21.29	21.47
3	8	0		20.04	20.55	21.14
3	8	4		20.24	20.52	21.09
3	8	7		20.28	20.34	20.91
3	15	0		20.12	20.40	20.98
1.4	1	0	QPSK	22.02	22.41	22.72
1.4	1	3		22.09	22.35	22.54
1.4	1	5		22.01	22.09	22.27
1.4	3	0		22.01	22.49	22.88
1.4	3	1		22.12	22.52	22.81
1.4	3	3		22.08	22.35	22.61
1.4	6	0		21.12	21.51	21.80
1.4	1	0	16-QAM	21.21	21.71	22.09
1.4	1	3		21.42	21.71	21.87
1.4	1	5		21.29	21.44	21.60
1.4	3	0		21.04	21.61	21.98
1.4	3	1		21.20	21.66	21.93
1.4	3	3		21.21	21.47	21.75
1.4	6	0		20.12	20.50	20.94



ERP

LTE Band 5 (GT - LC = 1.0 dB) QPSK									
Bandwidth	1.4M			3M			5M		
Channel	20407	20525	20643	20415	20525	20635	20425	20525	20625
	(Low)	(Mid)	(High)	(Low)	(Mid)	(High)	(Low)	(Mid)	(High)
Frequency	824.7	836.5	848.3	825.5	836.5	847.5	826.5	836.5	846.5
(MHz)									
Conducted Power (dBm)	22.01	22.49	22.88	22.02	22.29	22.81	22.44	22.41	22.93
Conducted Power (Watts)	0.1589	0.1774	0.1941	0.1592	0.1694	0.1910	0.1754	0.1742	0.1963
ERP(dBm)	20.86	21.34	21.73	20.87	21.14	21.66	21.29	21.26	21.78
ERP(Watts)	0.1219	0.1361	0.1489	0.1222	0.1300	0.1466	0.1346	0.1337	0.1507

LTE Band 5 (GT - LC = 1.0 dB) QPSK			
Bandwidth	10M		
Channel	20450	20525	20600
	(Low)	(Mid)	(High)
Frequency	829	836.5	844
(MHz)			
Conducted Power (dBm)	23.09	22.71	23.11
Conducted Power (Watts)	0.2037	0.1866	0.2046
ERP(dBm)	21.94	21.56	21.96
ERP(Watts)	0.1563	0.1432	0.1570



LTE Band 5 (GT - LC = 1.0 dB) 16QAM									
Bandwidth	1.4M			3M			5M		
Channel	20407	20525	20643	20415	20525	20635	20425	20525	20625
	(Low)	(Mid)	(High)	(Low)	(Mid)	(High)	(Low)	(Mid)	(High)
Frequency (MHz)	824.7	836.5	848.3	825.5	836.5	847.5	826.5	836.5	846.5
Conducted Power (dBm)	21.21	21.71	22.09	21.45	21.71	22.17	21.79	21.78	22.45
Conducted Power (Watts)	0.1321	0.1483	0.1618	0.1396	0.1483	0.1648	0.1510	0.1507	0.1758
ERP(dBm)	20.06	20.56	20.94	20.30	20.56	21.02	20.64	20.63	21.30
ERP(Watts)	0.1014	0.1138	0.1242	0.1072	0.1138	0.1265	0.1159	0.1156	0.1349

LTE Band 5 (GT - LC = 1.0 dB) 16QAM			
Bandwidth	10M		
Channel	20450	20525	20600
	(Low)	(Mid)	(High)
Frequency (MHz)	829	836.5	844
Conducted Power (dBm)	22.39	22.14	22.32
Conducted Power (Watts)	0.1734	0.1637	0.1706
ERP(dBm)	21.24	20.99	21.17
ERP(Watts)	0.1330	0.1256	0.1309



Peak-to-Average Ratio

Mode	LTE Band 5 / 10MHz				
Mod.	QPSK		16QAM		Limit: 13dB
RB Size	1RB	Full RB	1RB	Full RB	Result
Lowest CH	5.80	5.39	6.20	6.20	PASS
Middle CH	5.68	5.36	6.14	6.14	
Highest CH	5.83	5.48	6.35	6.26	



LTE Band 5 / 10MHz / QPSK

Lowest Channel / 1RB

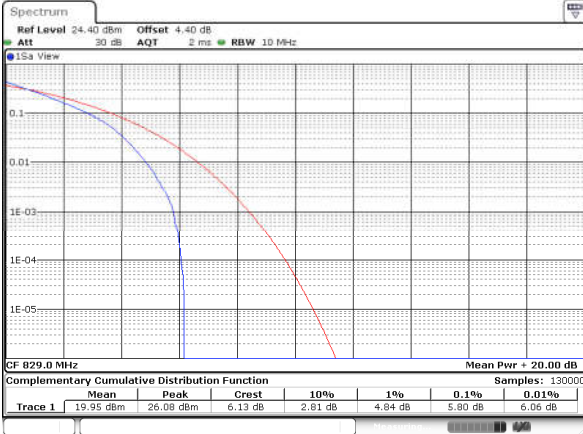

Date: 16 APR 2018 11:49:52

Lowest Channel / Full RB

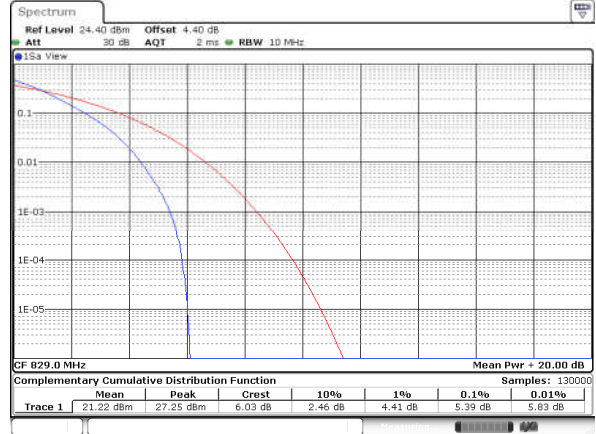

Date: 16 APR 2018 11:50:03

Middle Channel / 1RB

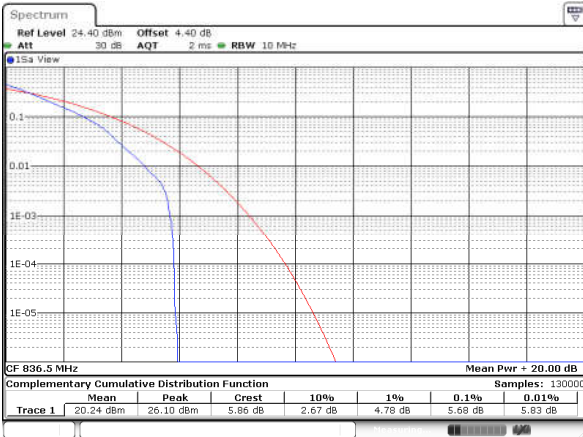

Date: 16 APR 2018 11:50:16

Middle Channel / Full RB

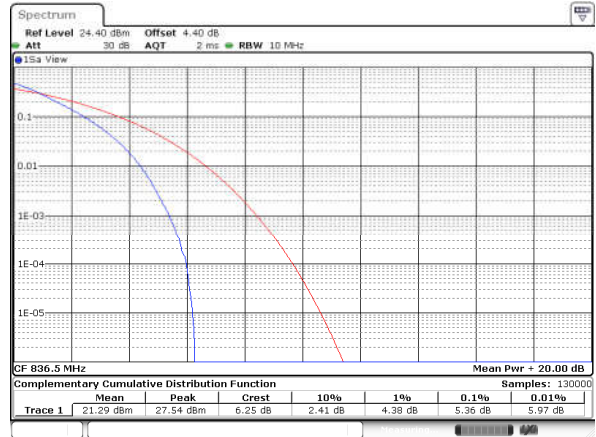

Date: 16 APR 2018 11:50:39

Highest Channel / 1RB

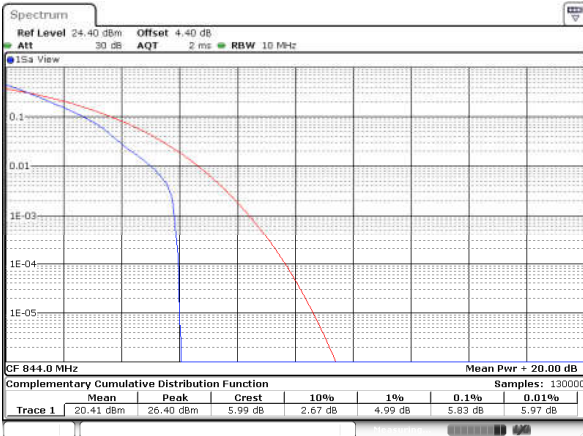

Date: 16 APR 2018 11:50:52

Highest Channel / Full RB

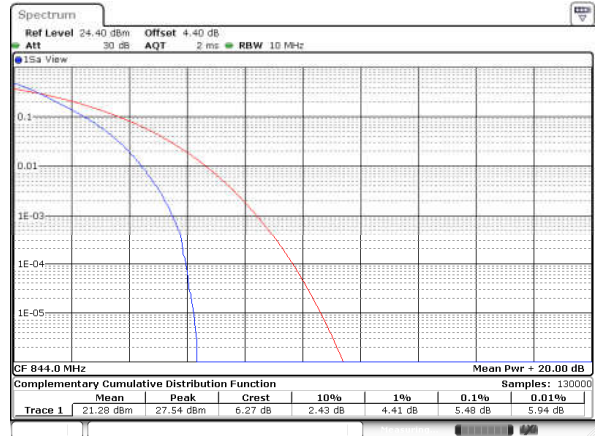

Date: 16 APR 2018 11:51:04



LTE Band 5 / 10MHz / 16QAM

Lowest Channel / 1RB

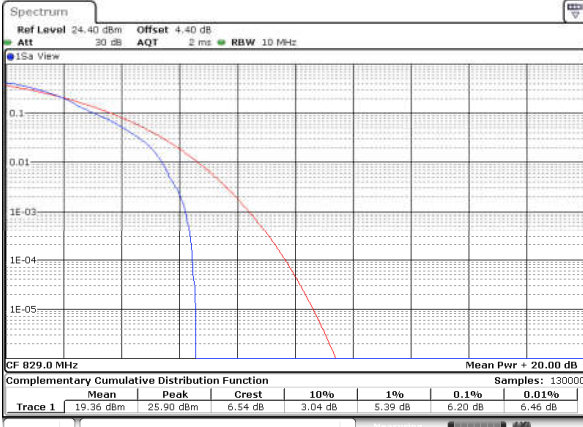

Date: 16 APR 2018 11:48:19

Lowest Channel / Full RB



Date: 16 APR 2018 11:48:37

Middle Channel / 1RB

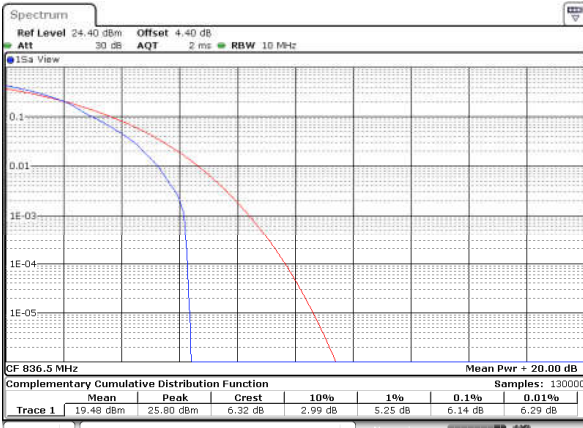

Date: 16 APR 2018 11:48:46

Middle Channel / Full RB

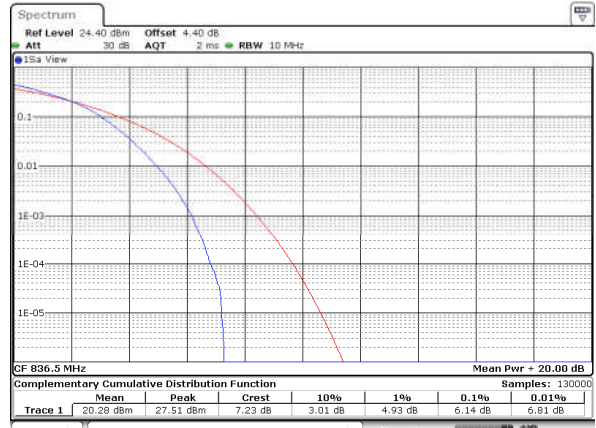

Date: 16 APR 2018 11:49:01

Highest Channel / 1RB

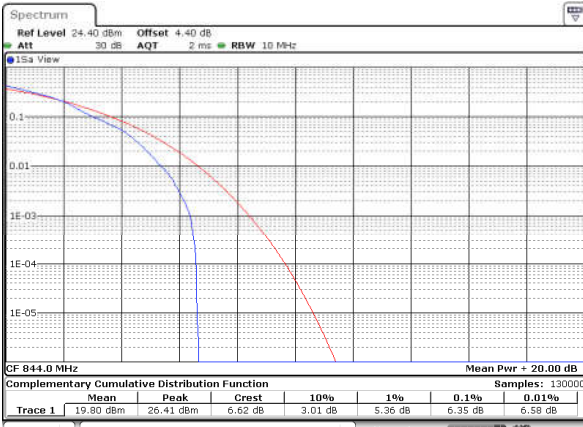

Date: 16 APR 2018 11:49:19

Highest Channel / Full RB

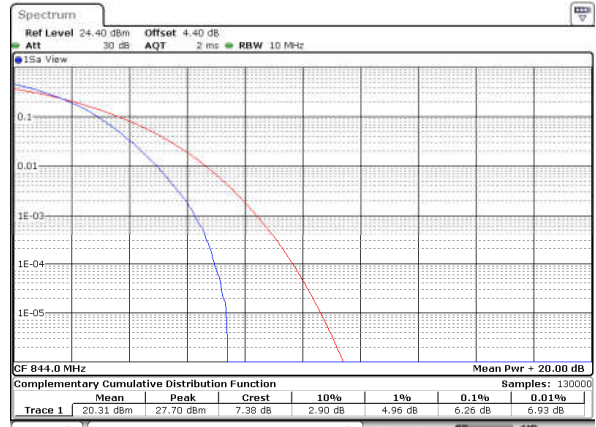

Date: 16 APR 2018 11:49:29



26dB Bandwidth

Mode	LTE Band 5 : 26dB BW(MHz)											
	1.4MHz		3MHz		5MHz		10MHz		15MHz		20MHz	
BW												
Mod.	QPSK	16QAM	QPSK	16QAM	QPSK	16QAM	QPSK	16QAM	QPSK	16QAM	QPSK	16QAM
Lowest CH	1.234	1.245	2.997	3.003	4.885	4.885	9.99	9.79	-	-	-	-
Middle CH	1.228	1.225	3.009	2.997	4.885	4.915	9.91	9.85	-	-	-	-
Highest CH	1.225	1.239	2.997	2.997	4.845	4.825	9.91	9.97	-	-	-	-



LTE Band 5

Lowest Channel / 1.4MHz / QPSK

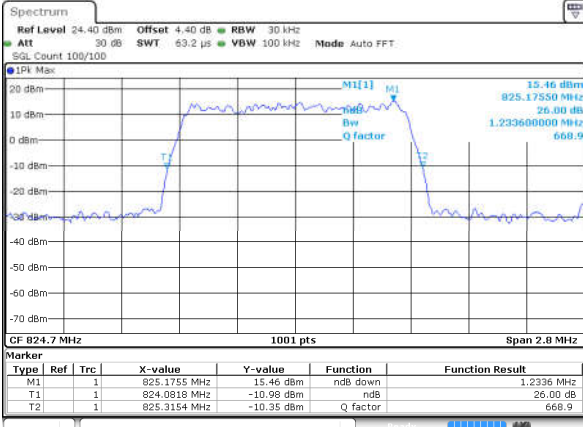

Date: 16 APR 2018 10:28:47

Lowest Channel / 1.4MHz / 16QAM

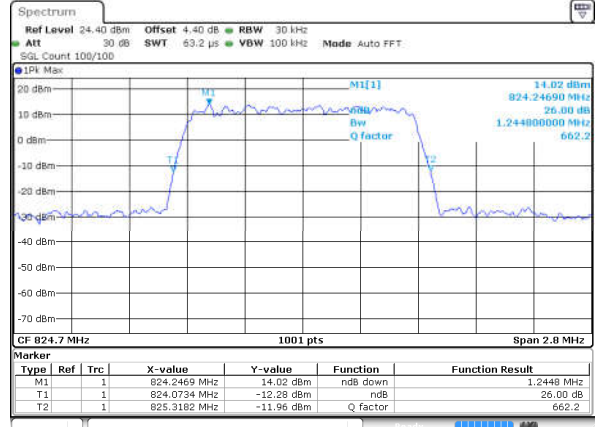

Date: 16 APR 2018 10:28:37

Middle Channel / 1.4MHz / QPSK

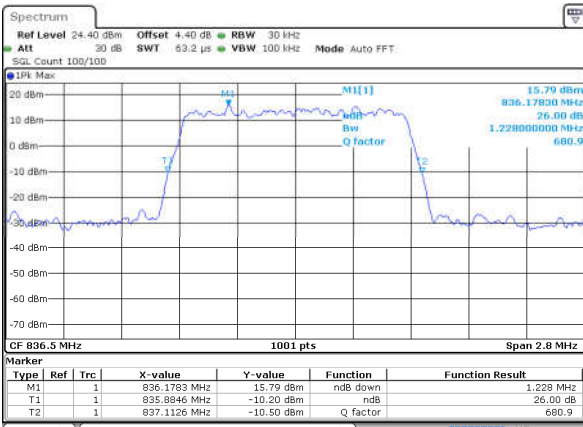

Date: 16 APR 2018 10:35:39

Middle Channel / 1.4MHz / 16QAM

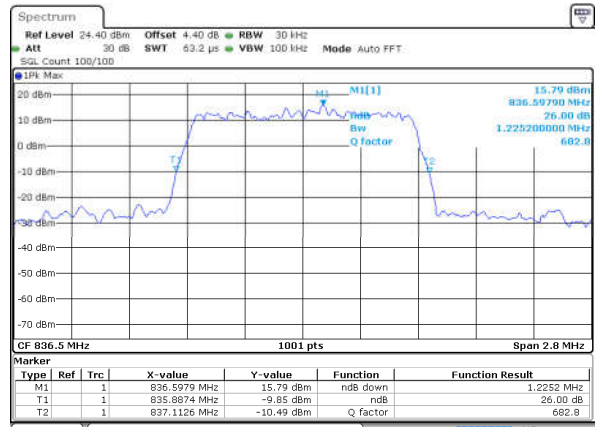

Date: 16 APR 2018 10:35:49

Highest Channel / 1.4MHz / QPSK

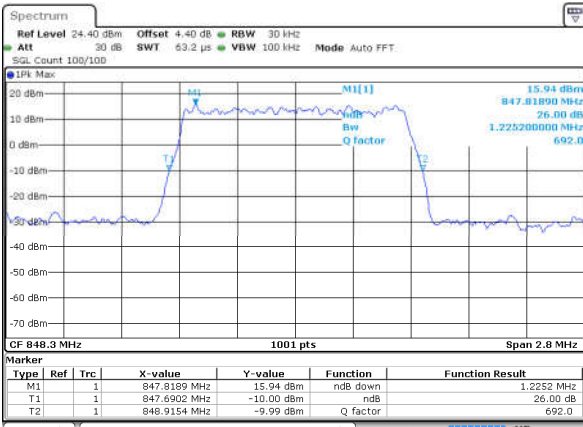

Date: 16 APR 2018 10:38:06

Highest Channel / 1.4MHz / 16QAM

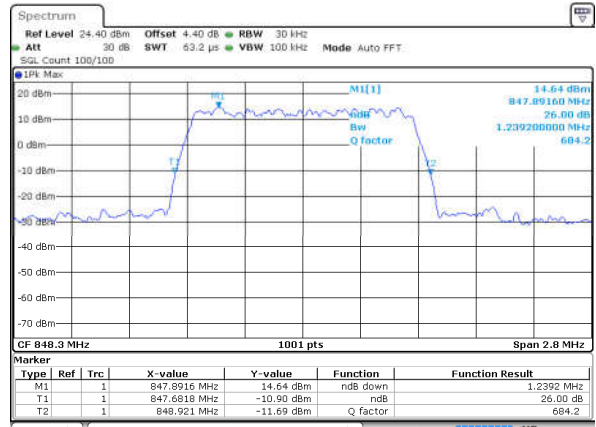

Date: 16 APR 2018 10:38:16



LTE Band 5

Lowest Channel / 3MHz / QPSK

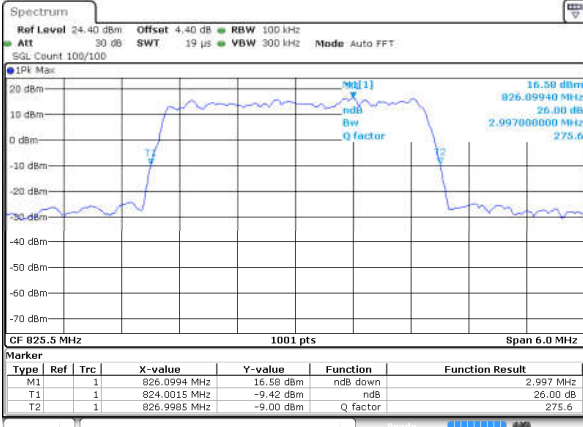

Date: 16 APR 2018 10:47:08

Lowest Channel / 3MHz / 16QAM

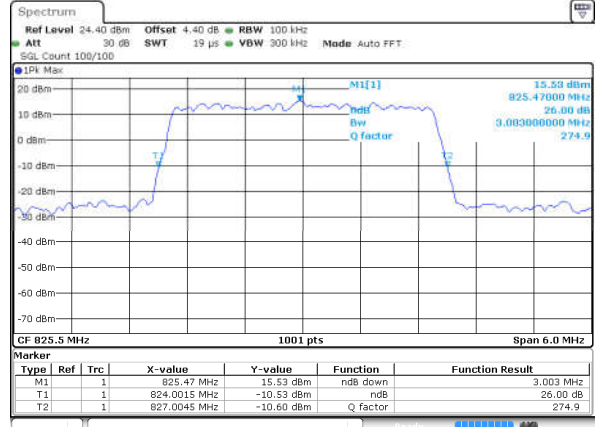

Date: 16 APR 2018 10:47:18

Middle Channel / 3MHz / QPSK

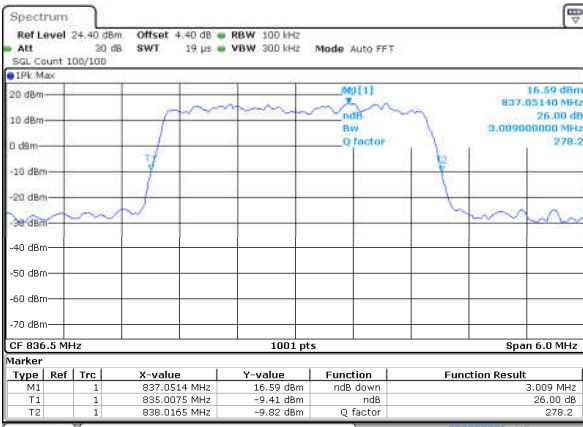

Date: 16 APR 2018 10:58:09

Middle Channel / 3MHz / 16QAM

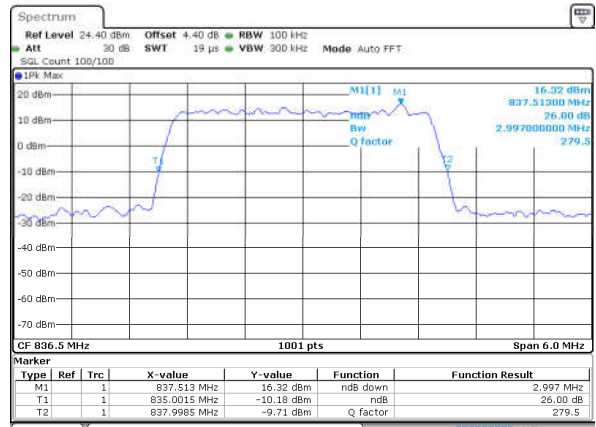

Date: 16 APR 2018 10:58:19

Highest Channel / 3MHz / QPSK

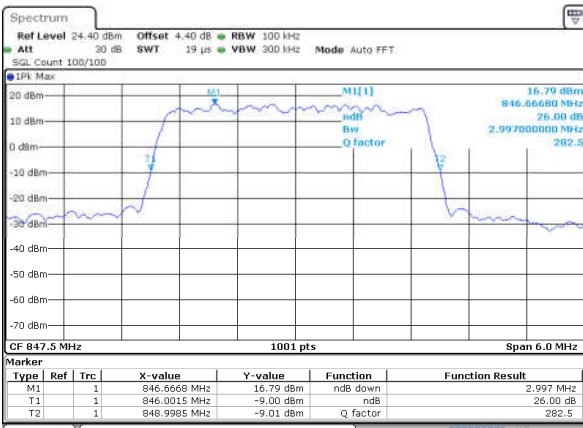

Date: 16 APR 2018 10:58:36

Highest Channel / 3MHz / 16QAM

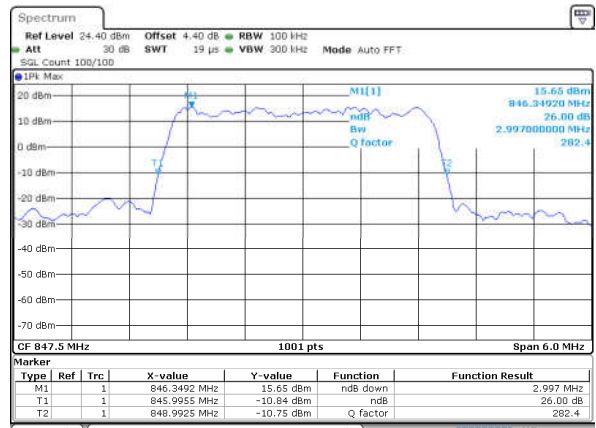

Date: 16 APR 2018 10:58:46



LTE Band 5

Lowest Channel / 5MHz / QPSK

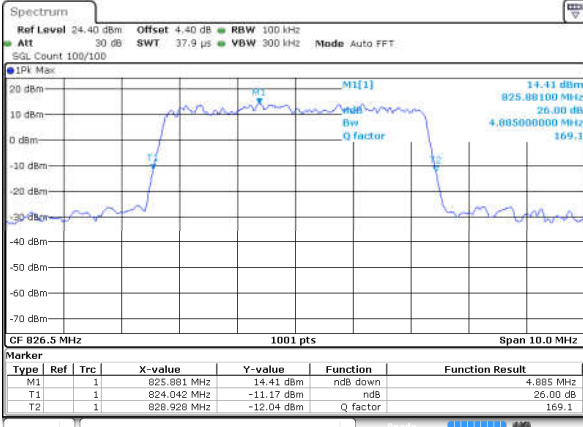

Date: 16 APR 2018 11:07:37

Lowest Channel / 5MHz / 16QAM

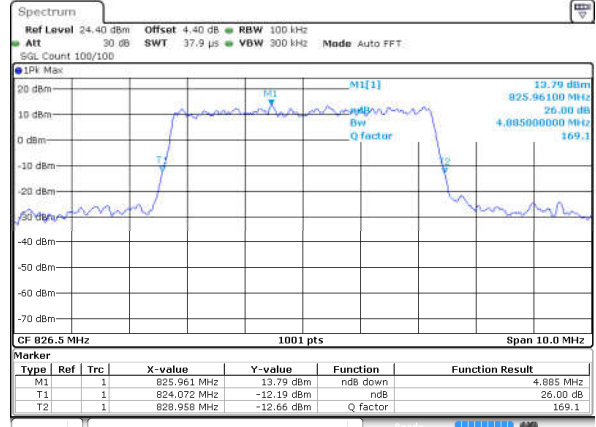

Date: 16 APR 2018 11:07:47

Middle Channel / 5MHz / QPSK

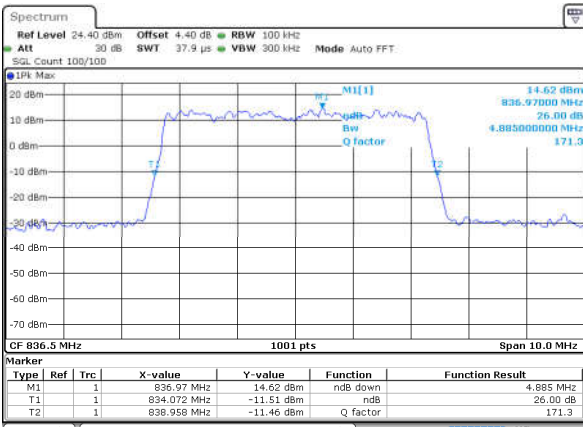

Date: 16 APR 2018 11:16:39

Middle Channel / 5MHz / 16QAM

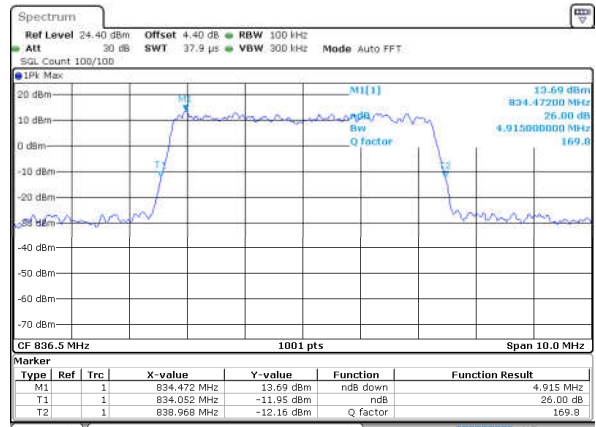

Date: 16 APR 2018 11:16:49

Highest Channel / 5MHz / QPSK

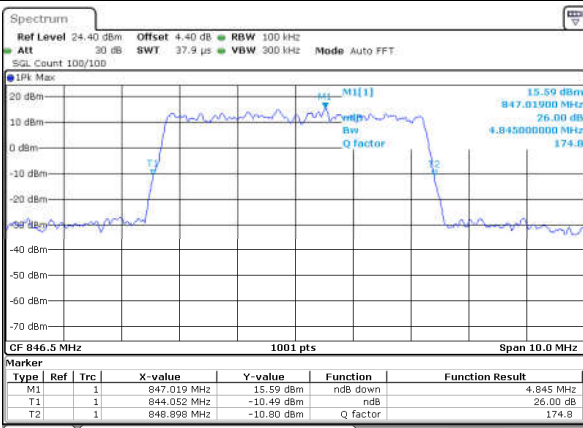

Date: 16 APR 2018 11:19:06

Highest Channel / 5MHz / 16QAM

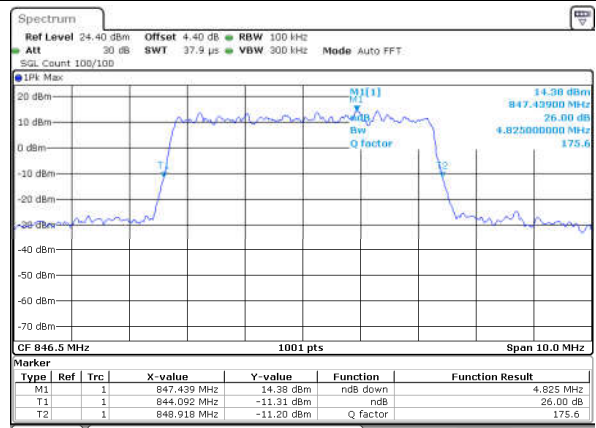

Date: 16 APR 2018 11:19:16



LTE Band 5

Lowest Channel / 10MHz / QPSK

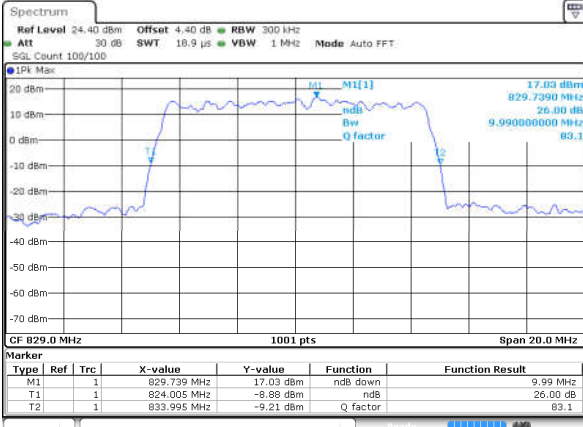

Date: 16 APR 2018 11:28:08

Lowest Channel / 10MHz / 16QAM

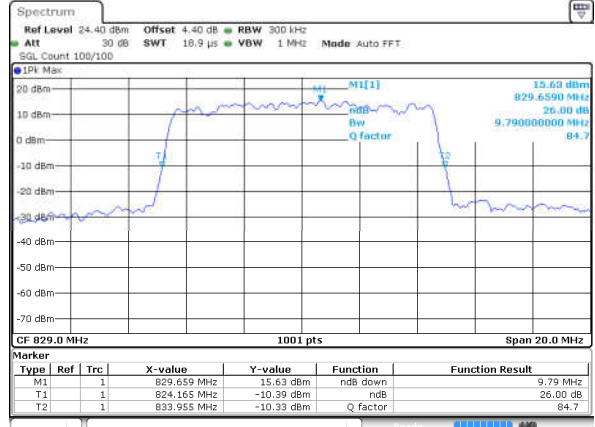

Date: 16 APR 2018 11:28:18

Middle Channel / 10MHz / QPSK

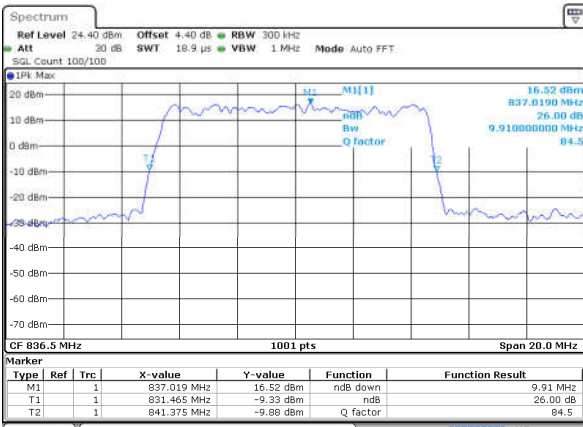

Date: 16 APR 2018 11:37:09

Middle Channel / 10MHz / 16QAM

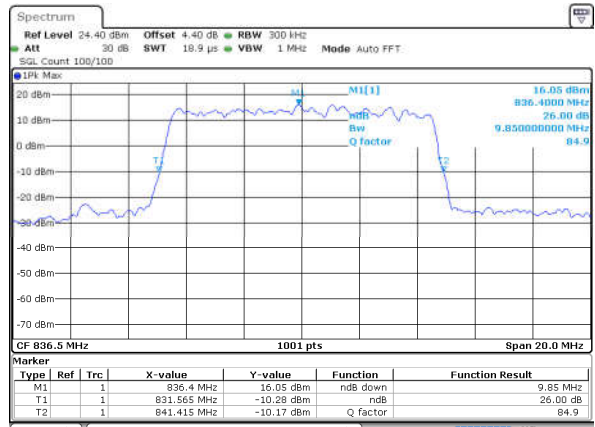

Date: 16 APR 2018 11:37:19

Highest Channel / 10MHz / QPSK

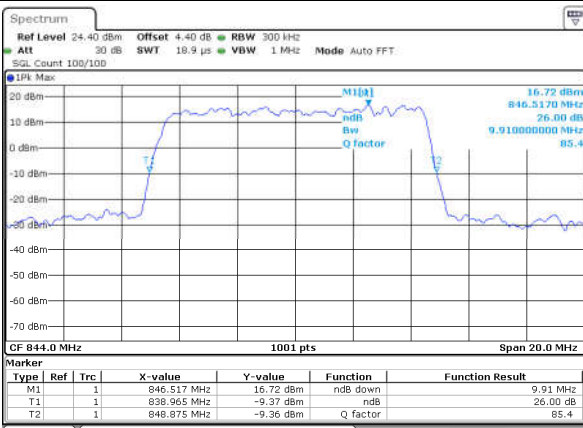

Date: 16 APR 2018 11:55:21

Highest Channel / 10MHz / 16QAM

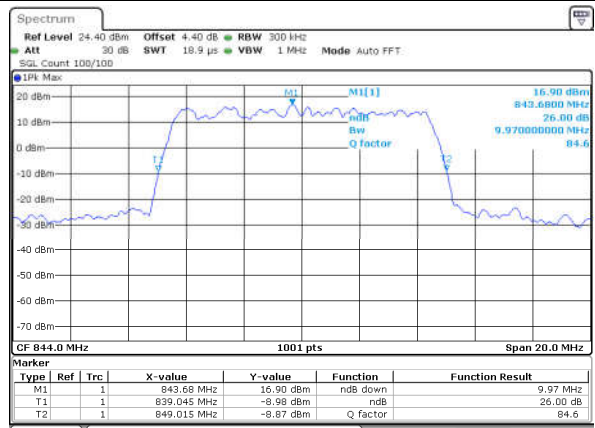

Date: 16 APR 2018 11:39:46



Occupied Bandwidth

Mode	LTE Band 5 : 99%OBW(MHz)											
	1.4MHz		3MHz		5MHz		10MHz		15MHz		20MHz	
BW												
Mod.	QPSK	16QAM	QPSK	16QAM	QPSK	16QAM	QPSK	16QAM	QPSK	16QAM	QPSK	16QAM
Lowest CH	1.09	1.10	2.73	2.73	4.48	4.48	8.99	9.05	-	-	-	-
Middle CH	1.10	1.09	2.72	2.71	4.50	4.50	9.03	9.01	-	-	-	-
Highest CH	1.08	1.09	2.71	2.73	4.48	4.50	8.99	9.03	-	-	-	-



LTE Band 5

Lowest Channel / 1.4MHz / QPSK

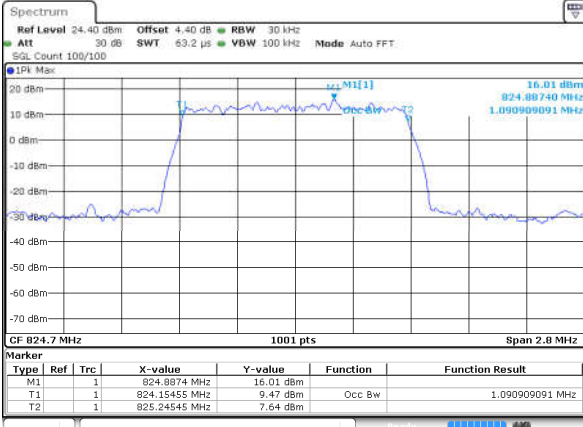

Date: 16 APR 2018 10:28:17

Lowest Channel / 1.4MHz / 16QAM

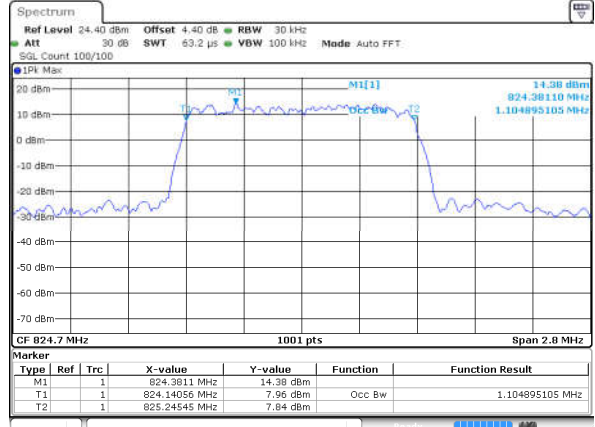

Date: 16 APR 2018 10:28:27

Middle Channel / 1.4MHz / QPSK

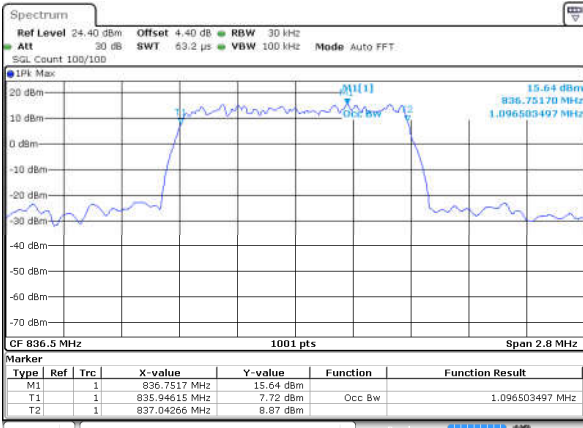

Date: 16 APR 2018 10:35:19

Middle Channel / 1.4MHz / 16QAM

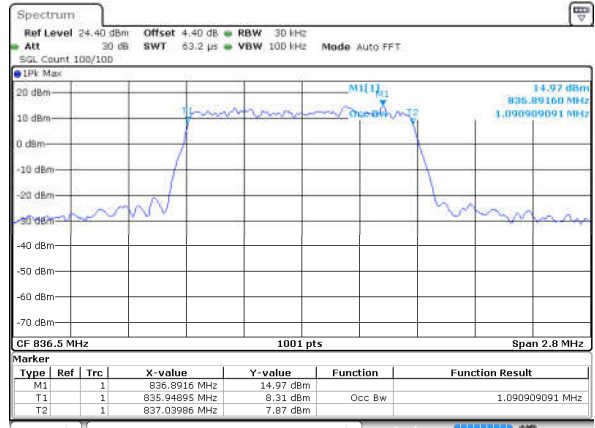

Date: 16 APR 2018 10:35:29

Highest Channel / 1.4MHz / QPSK

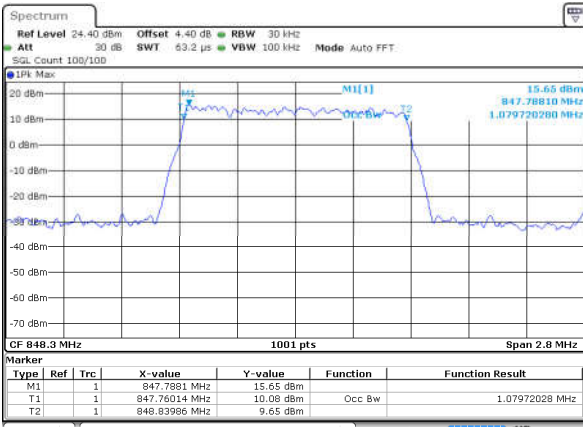

Date: 16 APR 2018 10:37:47

Highest Channel / 1.4MHz / 16QAM

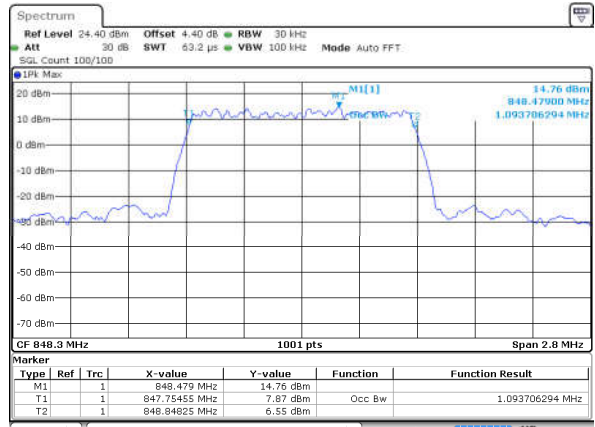

Date: 16 APR 2018 10:37:57



LTE Band 5

Lowest Channel / 3MHz / QPSK

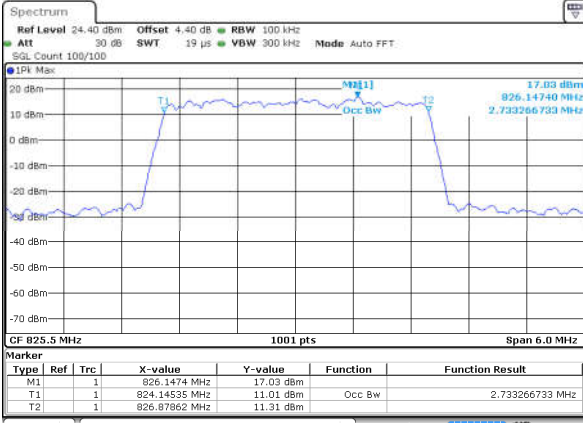

Date: 16 APR 2018 10:46:48

Lowest Channel / 3MHz / 16QAM

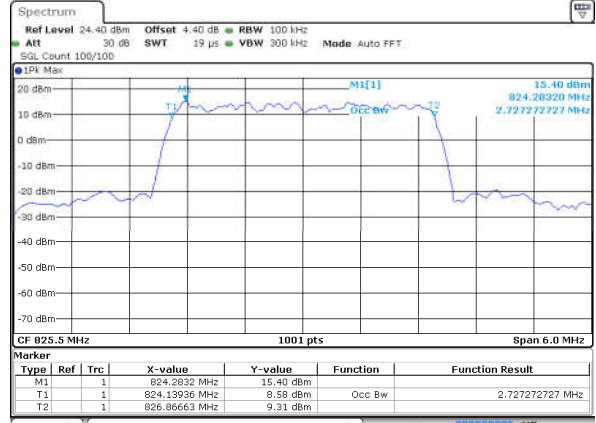

Date: 16 APR 2018 10:46:58

Middle Channel / 3MHz / QPSK

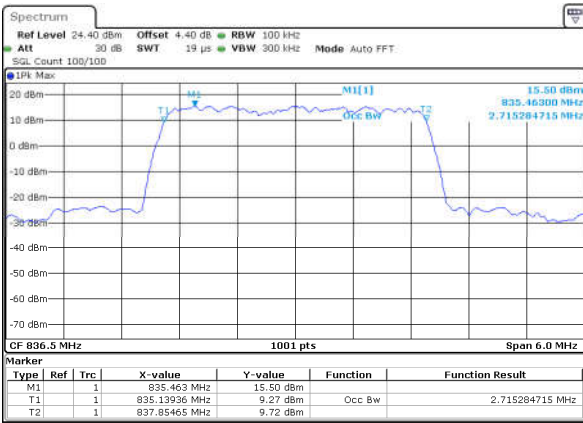

Date: 16 APR 2018 10:55:49

Middle Channel / 3MHz / 16QAM

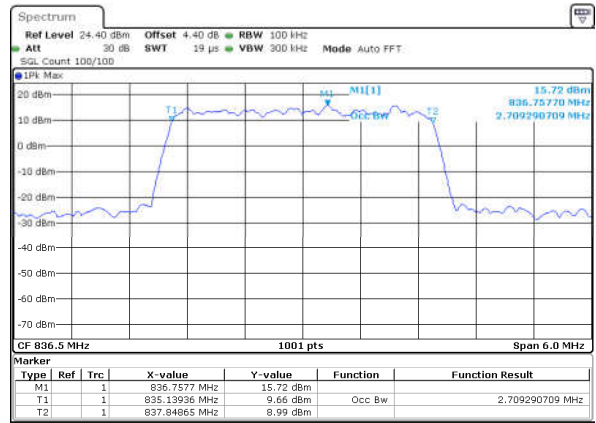

Date: 16 APR 2018 10:55:59

Highest Channel / 3MHz / QPSK

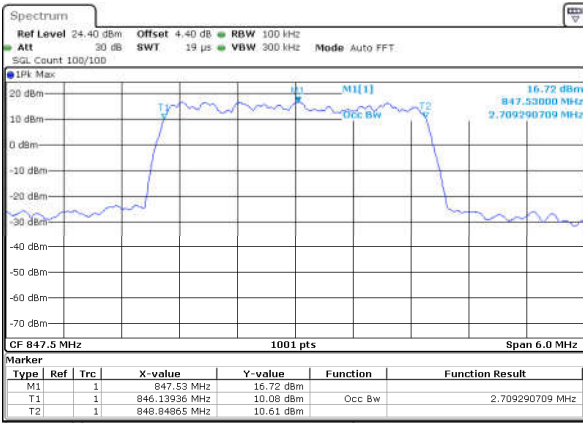

Date: 16 APR 2018 10:58:16

Highest Channel / 3MHz / 16QAM

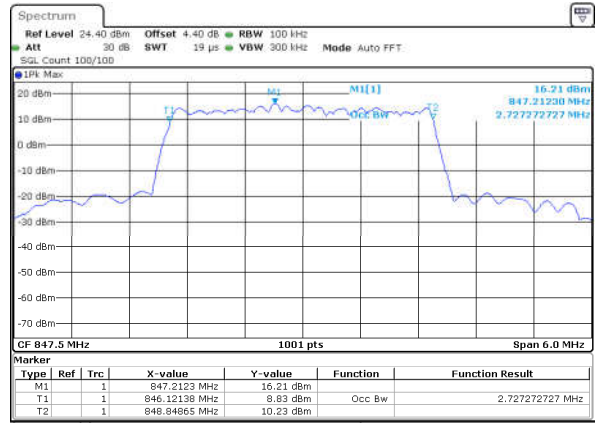

Date: 16 APR 2018 10:58:26



LTE Band 5

Lowest Channel / 5MHz / QPSK

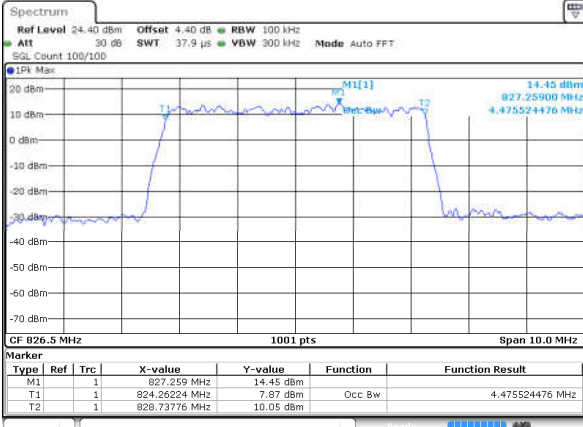

Date: 16 APR 2018 11:07:17

Lowest Channel / 5MHz / 16QAM

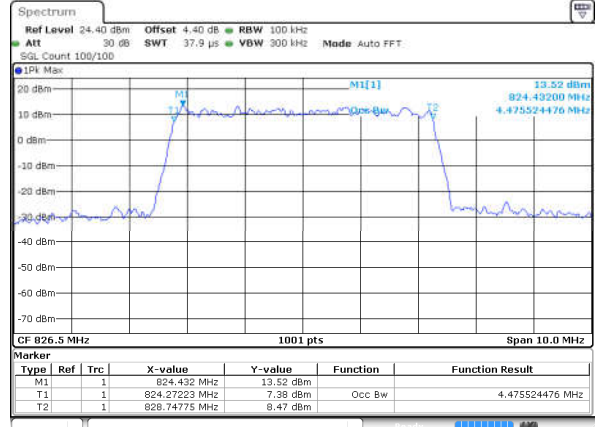

Date: 16 APR 2018 11:07:27

Middle Channel / 5MHz / QPSK

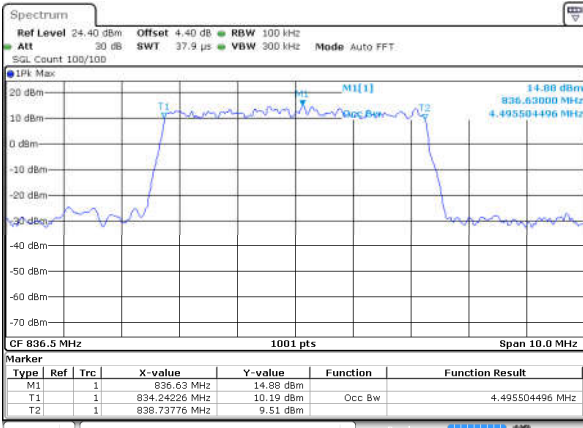

Date: 16 APR 2018 11:16:19

Middle Channel / 5MHz / 16QAM

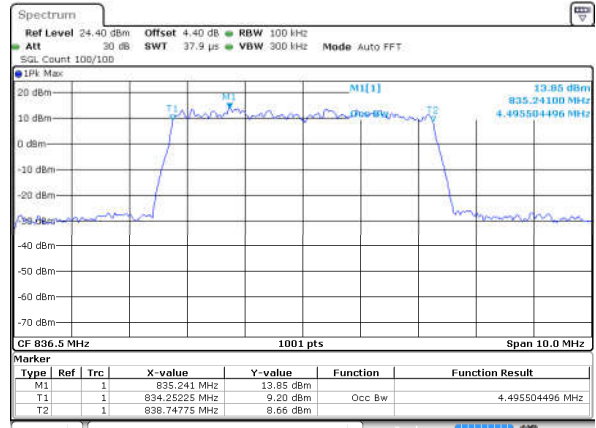

Date: 16 APR 2018 11:16:29

Highest Channel / 5MHz / QPSK

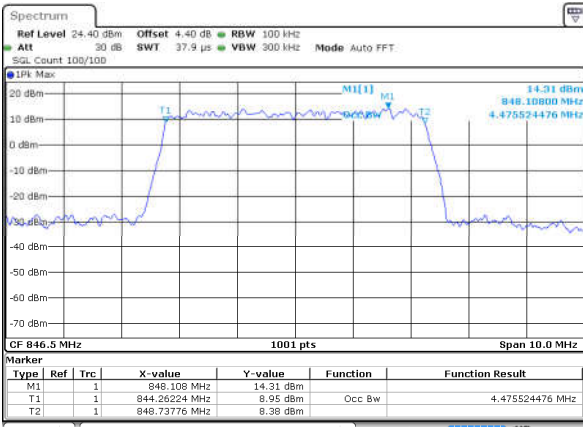

Date: 16 APR 2018 11:18:46

Highest Channel / 5MHz / 16QAM

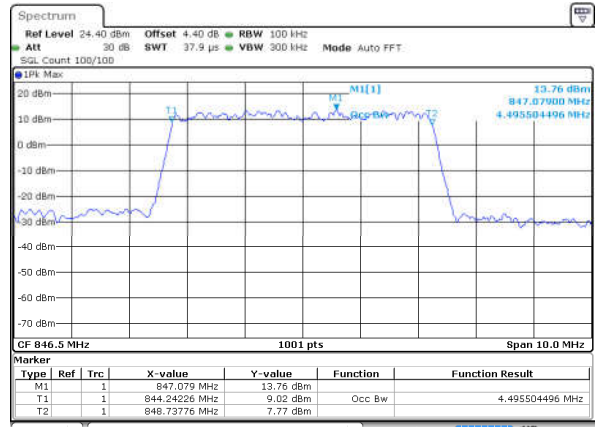

Date: 16 APR 2018 11:18:56



LTE Band 5

Lowest Channel / 10MHz / QPSK

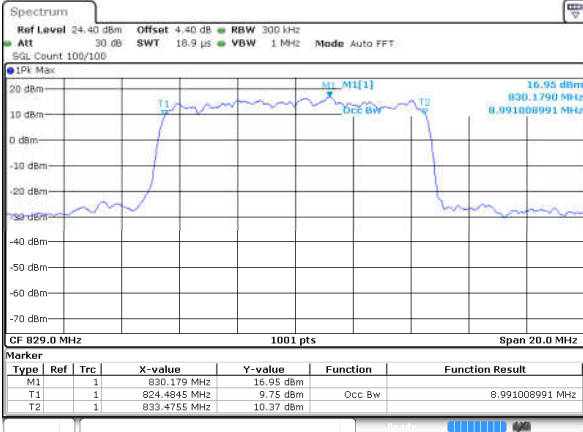

Date: 16 APR 2018 11:27:48

Lowest Channel / 10MHz / 16QAM

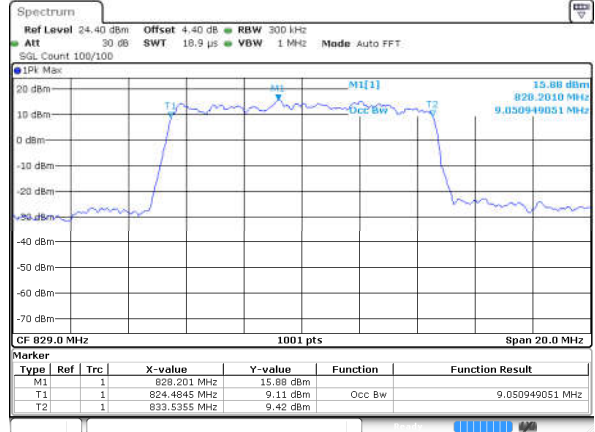

Date: 16 APR 2018 11:27:58

Middle Channel / 10MHz / QPSK

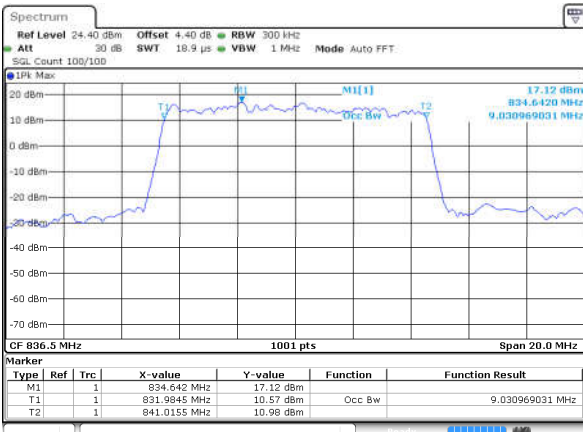

Date: 16 APR 2018 11:36:49

Middle Channel / 10MHz / 16QAM

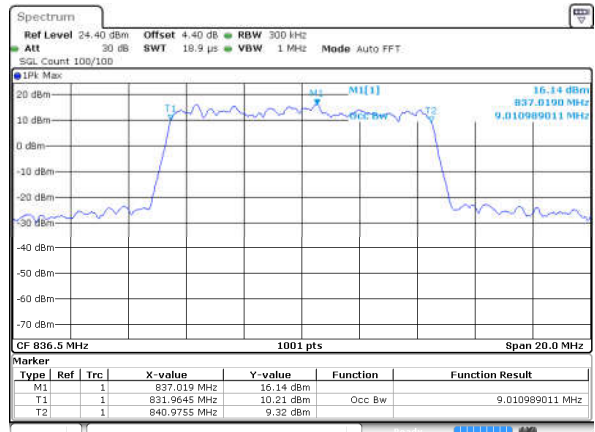

Date: 16 APR 2018 11:36:59

Highest Channel / 10MHz / QPSK

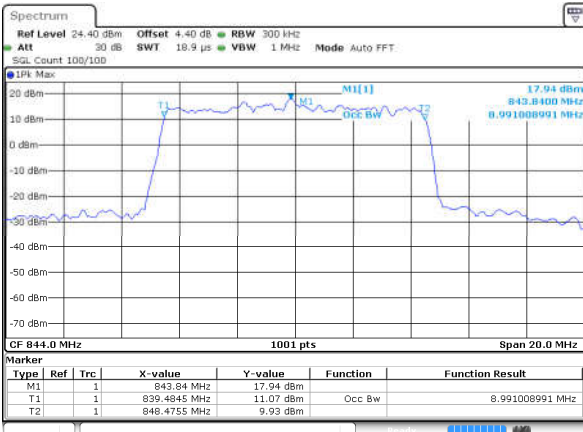

Date: 16 APR 2018 11:39:16

Highest Channel / 10MHz / 16QAM

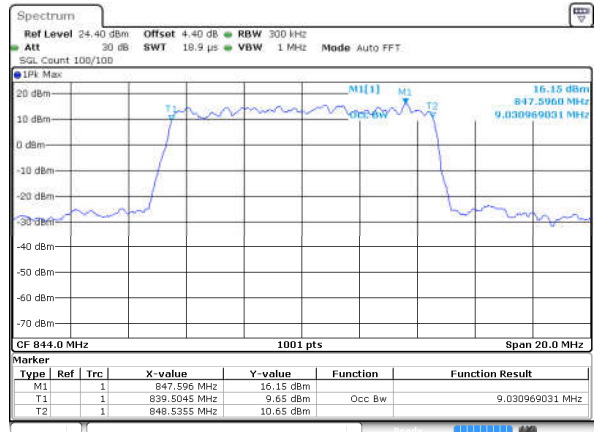

Date: 16 APR 2018 11:39:26



Conducted Band Edge

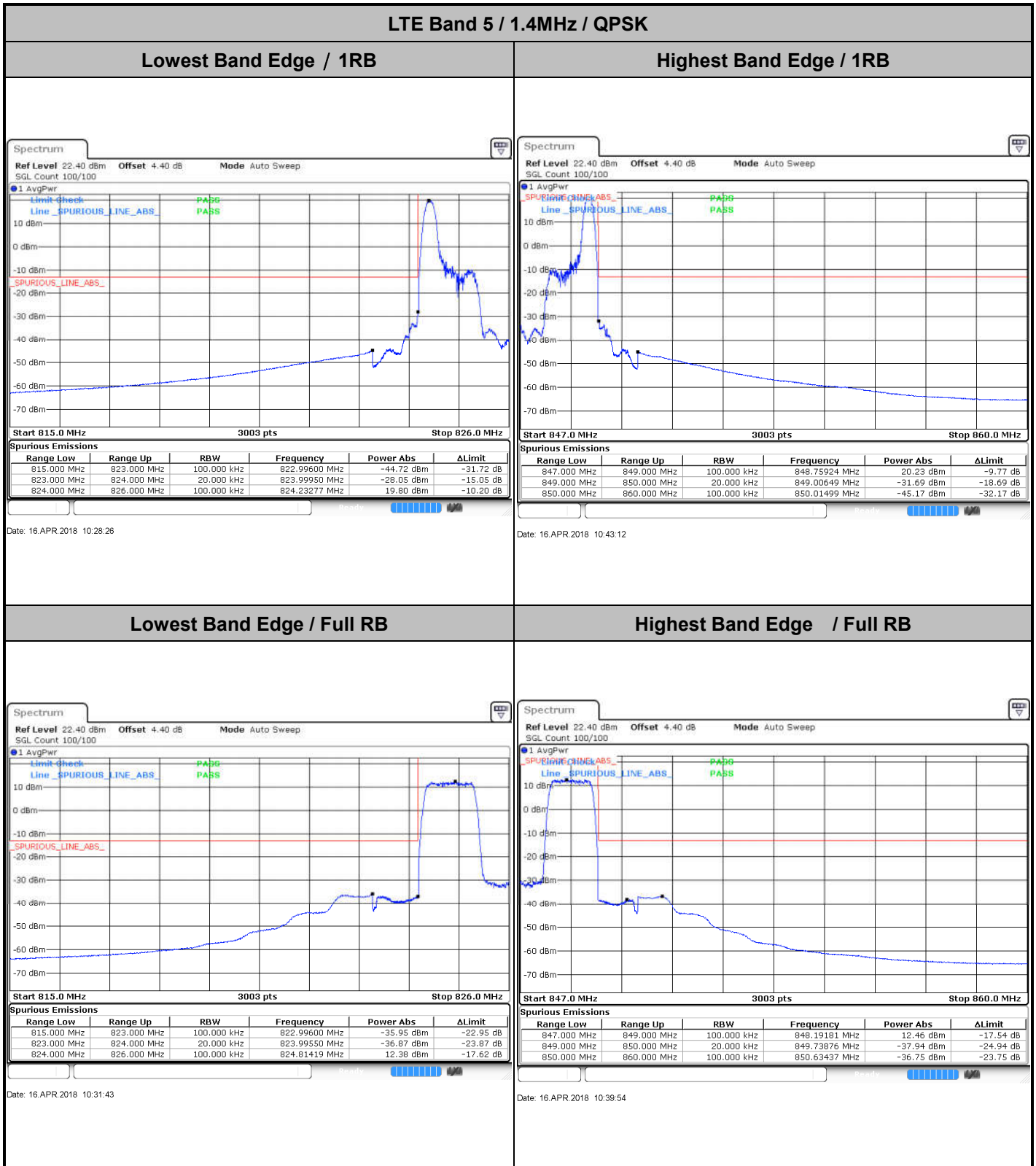



LTE Band 5 / 1.4MHz / 16QAM

Lowest Band Edge / 1 RB

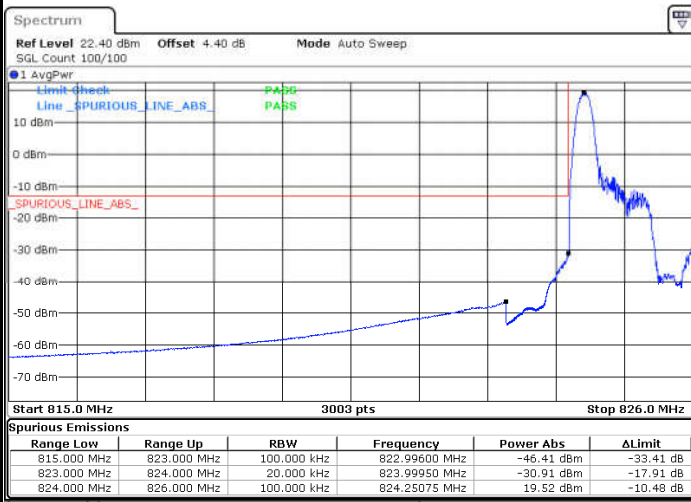

Date: 16 APR 2018 10:30:05

Highest Band Edge / 1 RB



Date: 16 APR 2018 10:44:50

Lowest Band Edge / Full RB

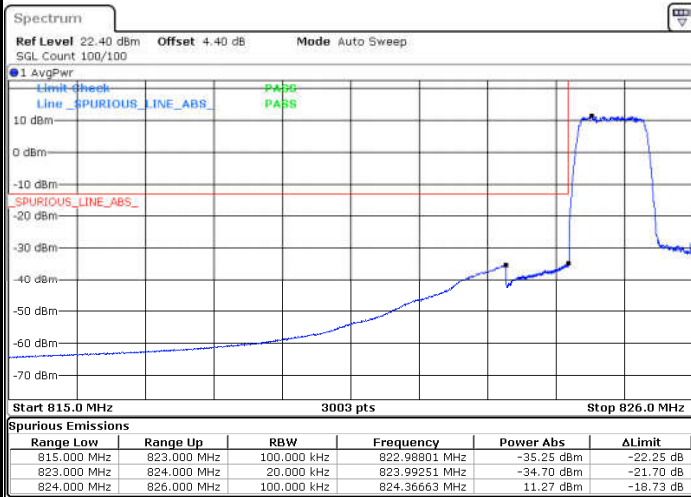

Date: 16 APR 2018 10:33:22

Highest Band Edge / Full RB



Date: 16 APR 2018 11:54:25



LTE Band 5 / 3MHz / QPSK

Lowest Band Edge / 1RB

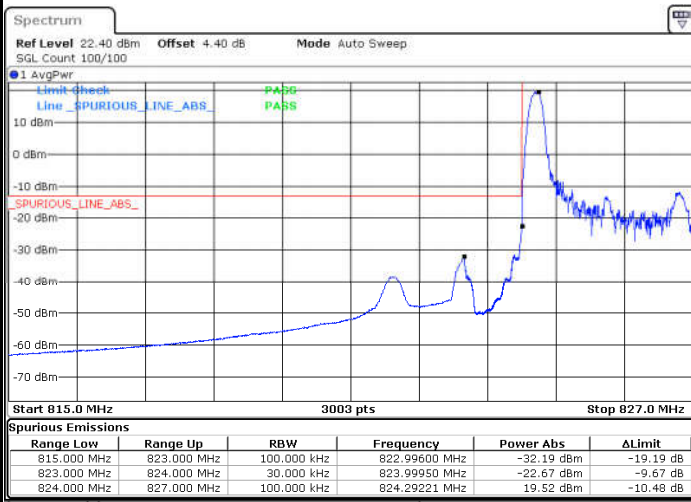

Date: 16.APR.2018 10:48:56

Highest Band Edge / 1 RB

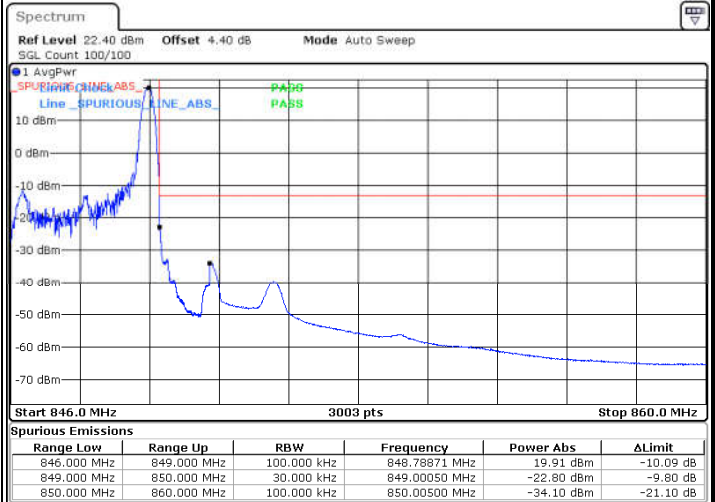

Date: 16.APR.2018 11:00:24

Lowest Band Edge / Full RB

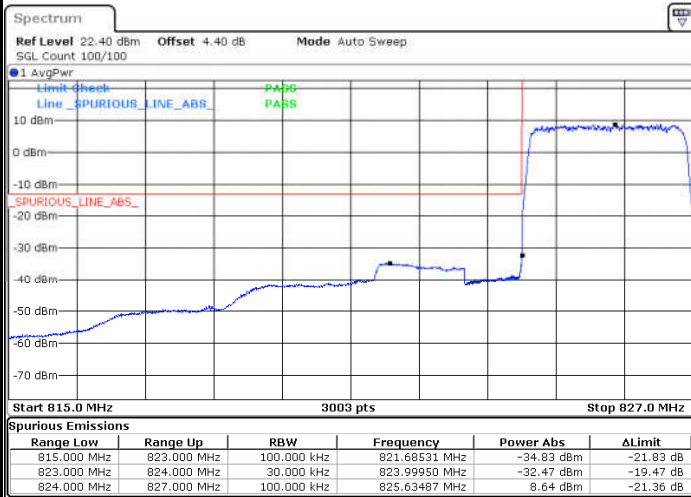

Date: 16.APR.2018 10:52:13

Highest Band Edge / Full RB



Date: 16.APR.2018 11:03:41



LTE Band 5 / 3MHz / 16QAM

Lowest Band Edge / 1 RB

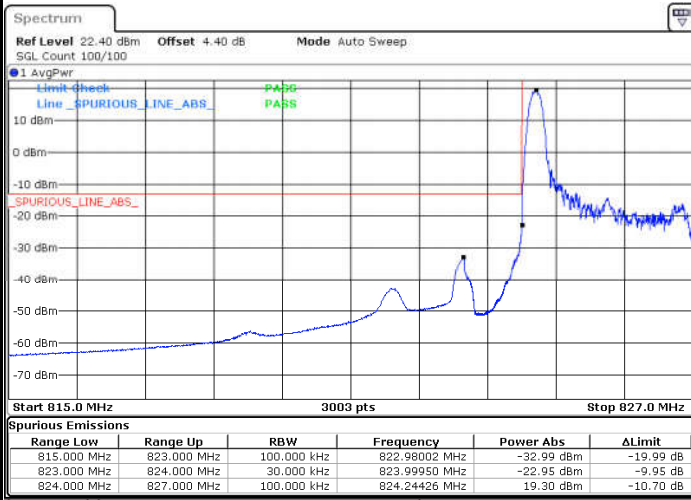

Date: 16.APR.2018 10:50:34

Highest Band Edge / 1 RB



Date: 16.APR.2018 11:02:03

Lowest Band Edge / Full RB

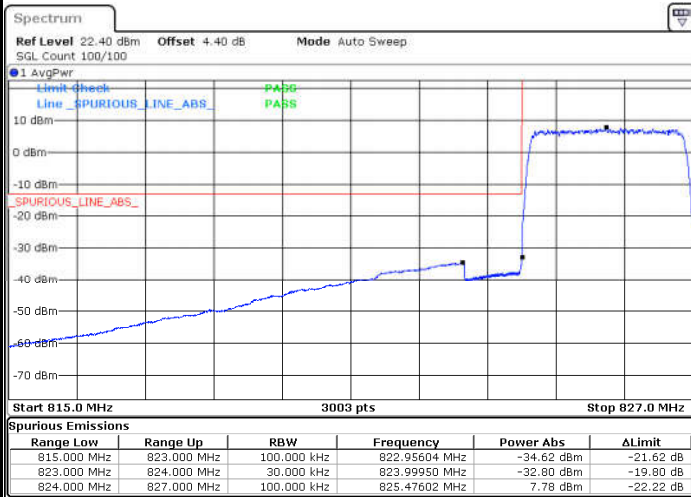

Date: 16.APR.2018 10:53:52

Highest Band Edge / Full RB

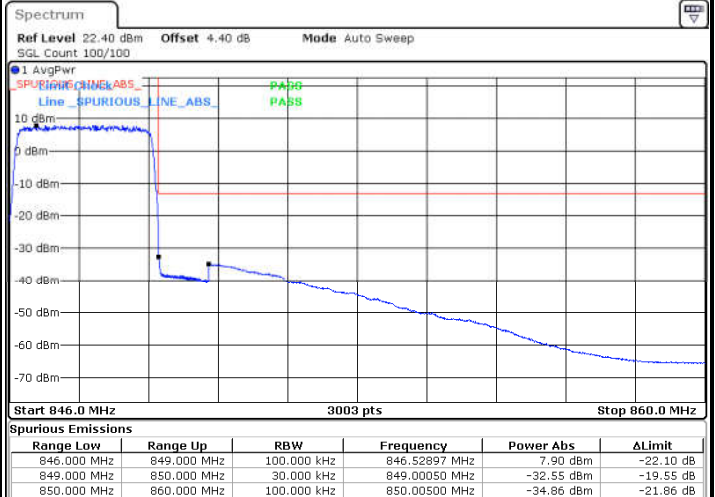

Date: 16.APR.2018 11:05:20



LTE Band 5 / 5MHz / QPSK

Lowest Band Edge / 1 RB

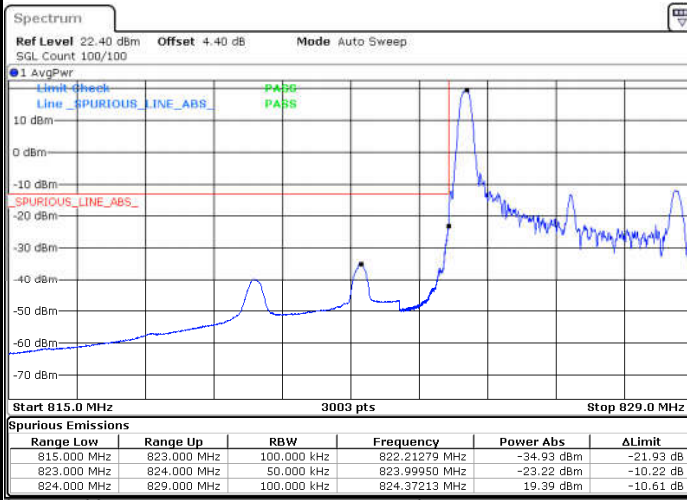

Date: 16.APR.2018 11:09:25

Highest Band Edge / 1 RB

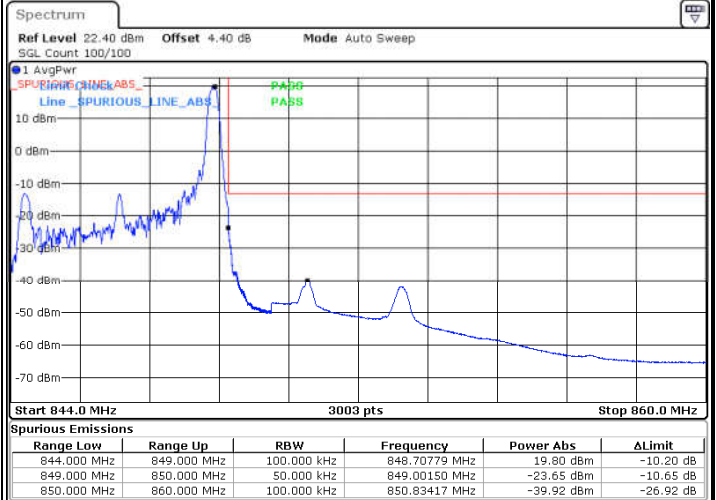

Date: 16.APR.2018 11:20:54

Lowest Band Edge / Full RB

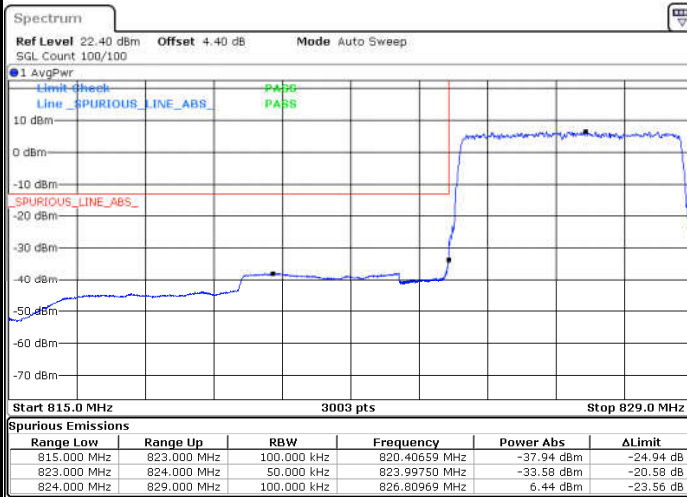

Date: 16.APR.2018 11:12:43

Highest Band Edge / Full RB



Date: 16.APR.2018 11:24:11



LTE Band 5 / 5MHz / 16QAM

Lowest Band Edge / 1RB

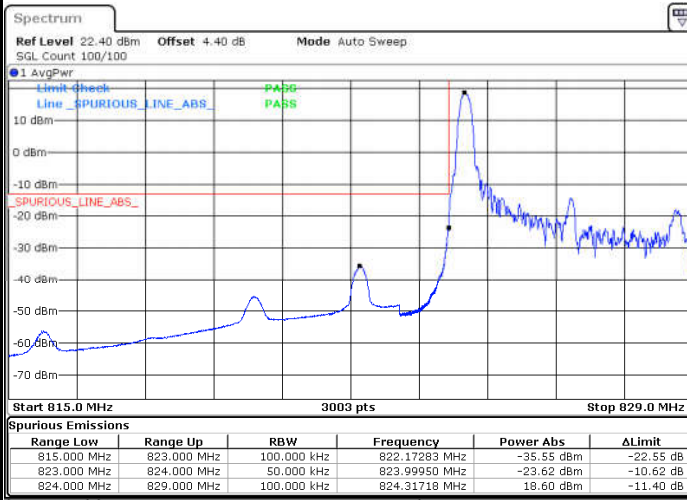

Date: 16.APR.2018 11:11:04

Highest Band Edge / 1 RB

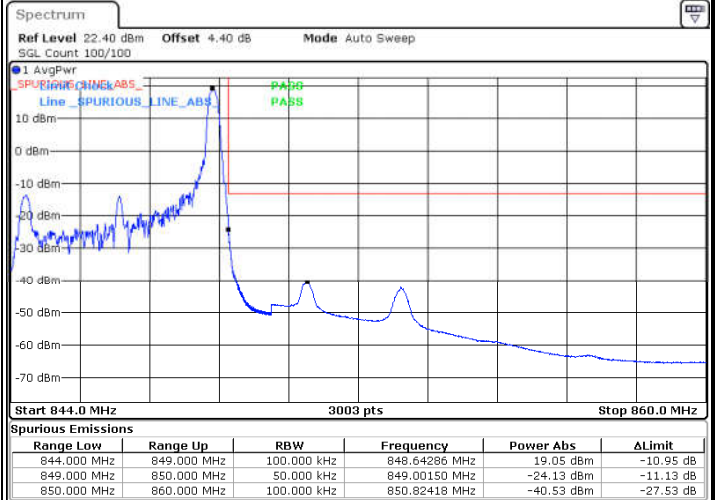

Date: 16.APR.2018 11:22:33

Lowest Band Edge / Full RB

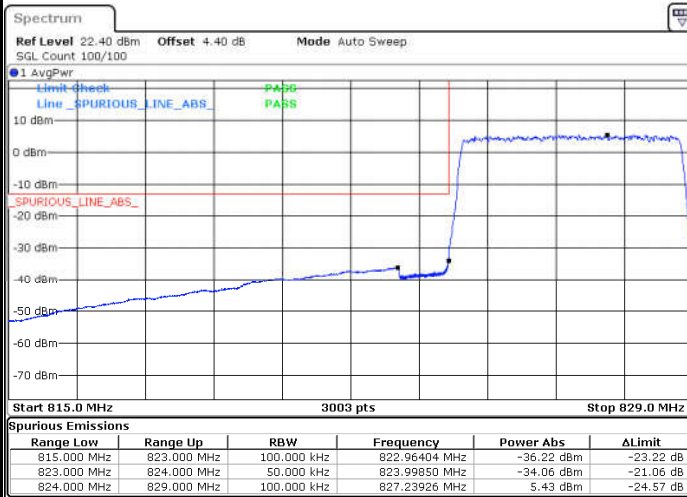

Date: 16.APR.2018 11:14:21

Highest Band Edge / Full RB



Date: 16.APR.2018 11:25:50



LTE Band 5 / 10MHz / QPSK

Lowest Band Edge / 1 RB

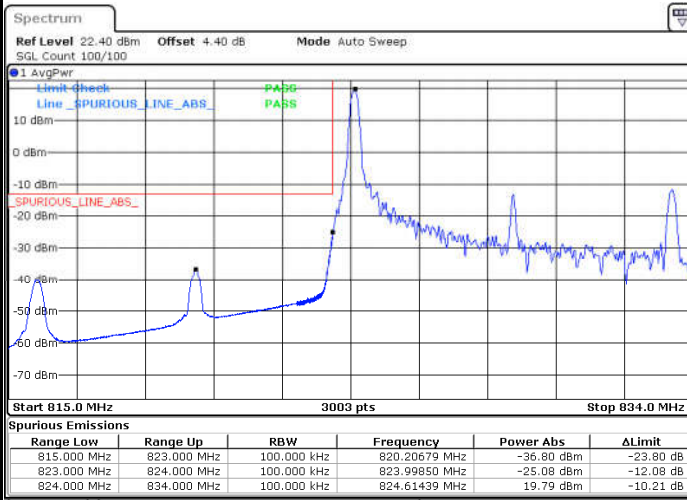

Date: 16 APR 2018 11:29:56

Highest Band Edge / 1 RB

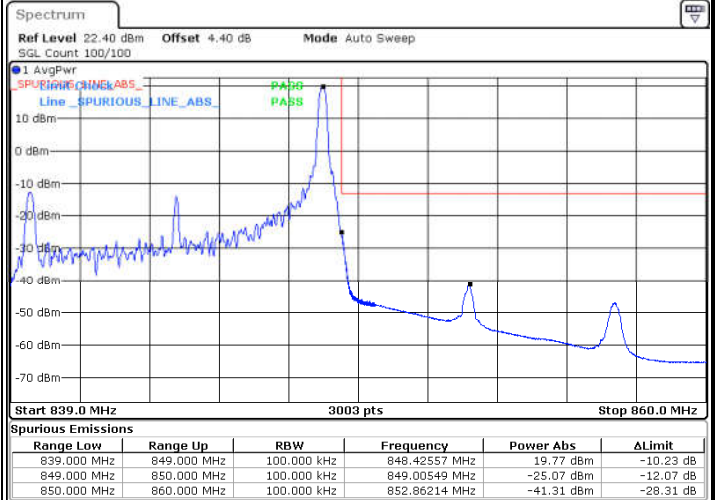

Date: 16 APR 2018 11:41:24

Lowest Band Edge / Full RB

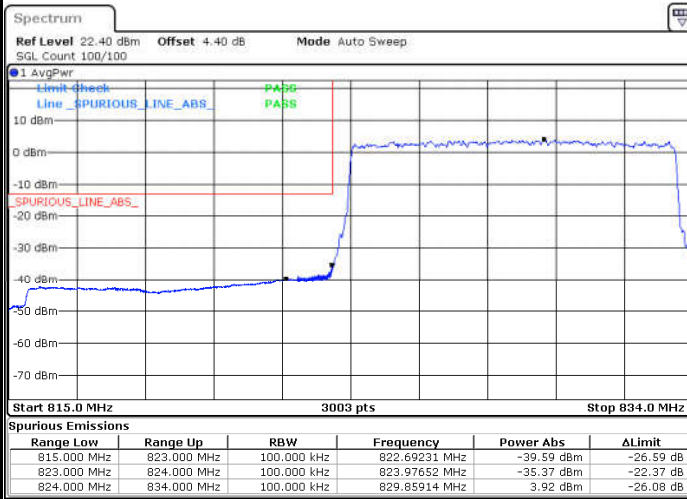

Date: 16 APR 2018 11:33:13

Highest Band Edge / Full RB



Date: 16 APR 2018 11:44:41



LTE Band 5 / 10MHz / 16QAM

Lowest Band Edge / 1 RB

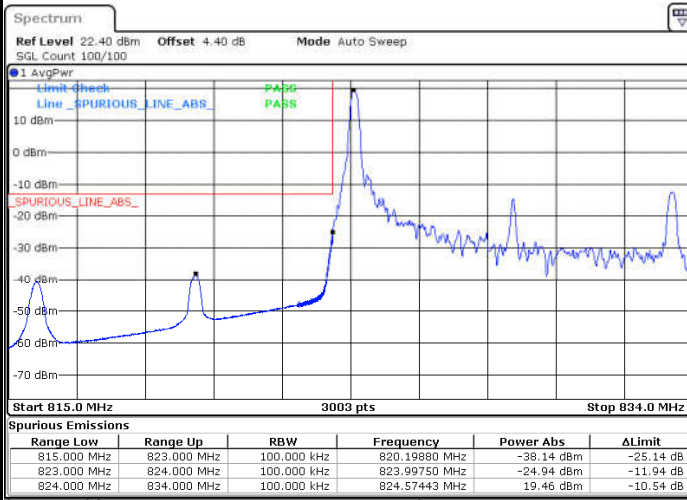

Date: 16.APR.2018 11:31:34

Highest Band Edge / 1 RB

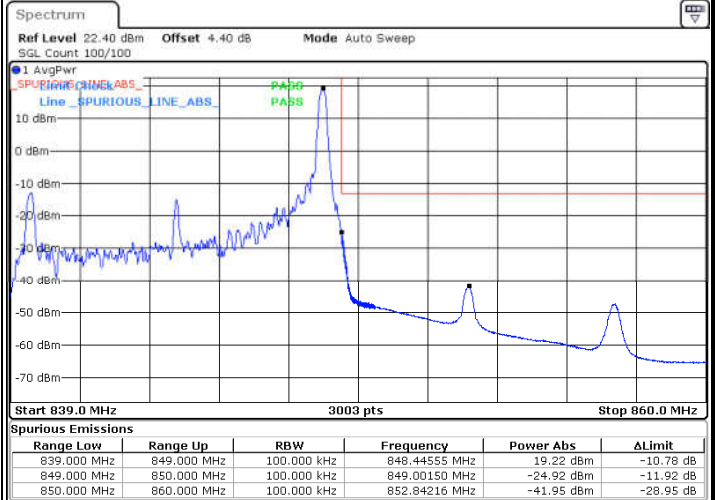

Date: 16.APR.2018 11:43:03

Lowest Band Edge / Full RB

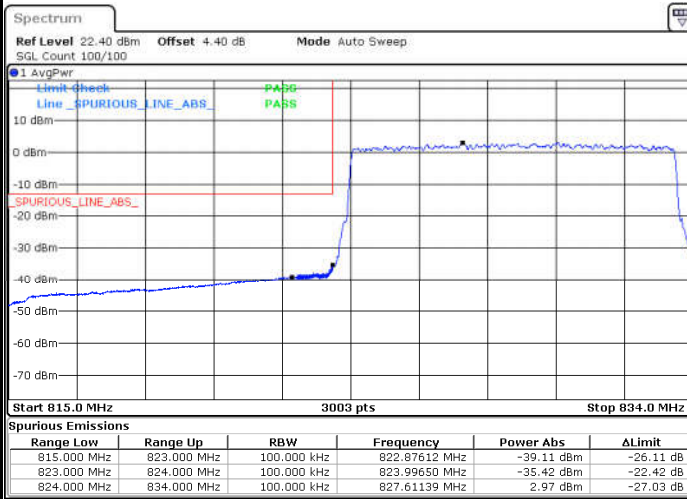

Date: 16.APR.2018 11:34:52

Highest Band Edge / Full RB



Date: 16.APR.2018 11:46:20



Conducted Spurious Emission

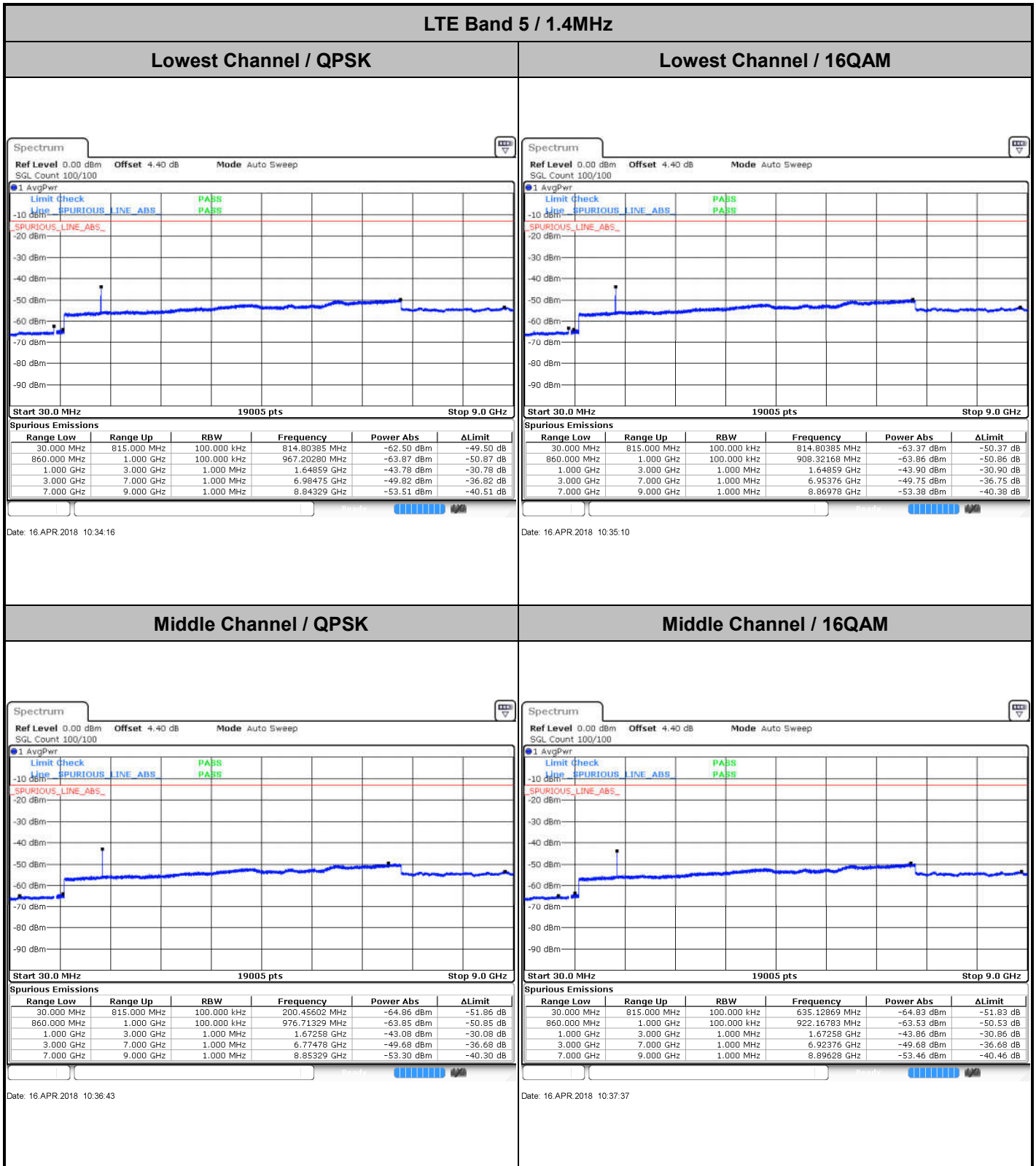



LTE Band 5 / 1.4MHz

Highest Channel / QPSK

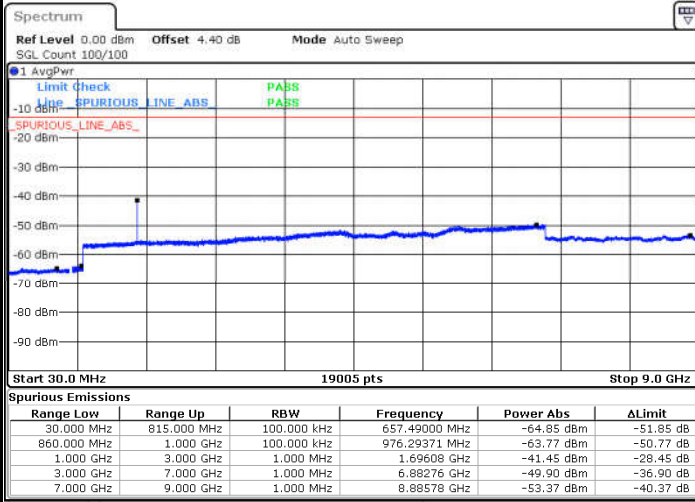

Date: 16.APR.2018 10:45:44

Highest Channel / 16QAM

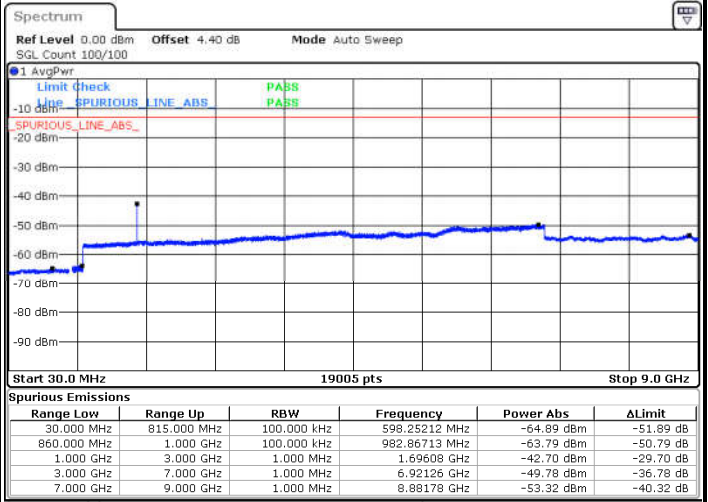

Date: 16.APR.2018 10:46:38

LTE Band 5 / 3MHz

Lowest Channel / QPSK

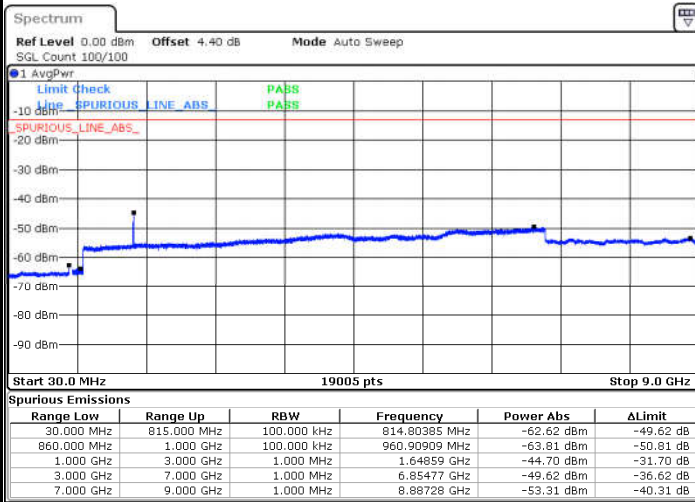

Date: 16.APR.2018 10:54:46

Lowest Channel / 16QAM

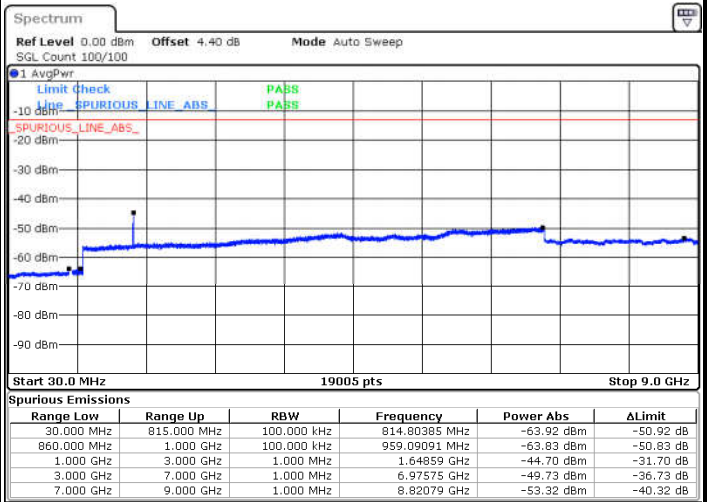

Date: 16.APR.2018 10:55:39



LTE Band 5 / 3MHz

Middle Channel / QPSK

Middle Channel / 16QAM

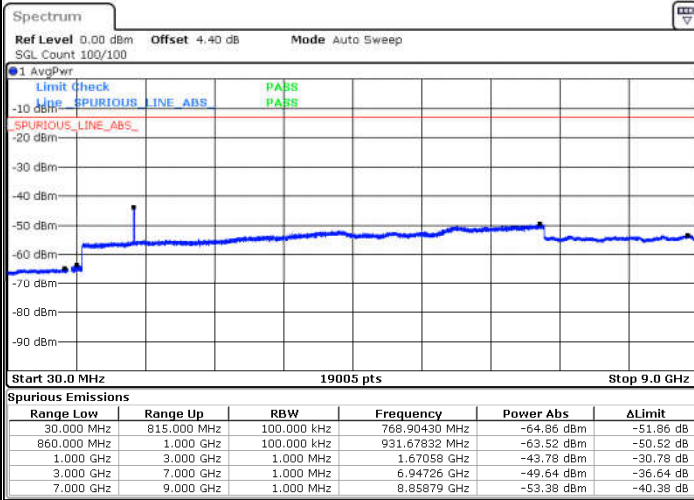

Date: 16.APR.2018 10:57:13

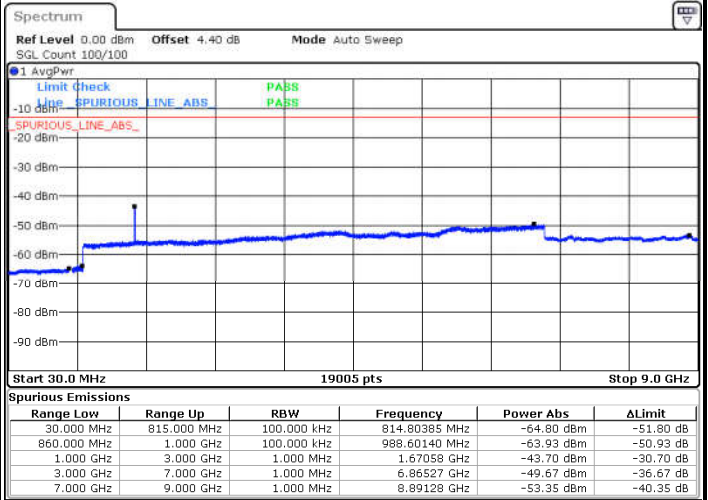

Date: 16.APR.2018 10:58:06

Highest Channel / QPSK

Highest Channel / 16QAM

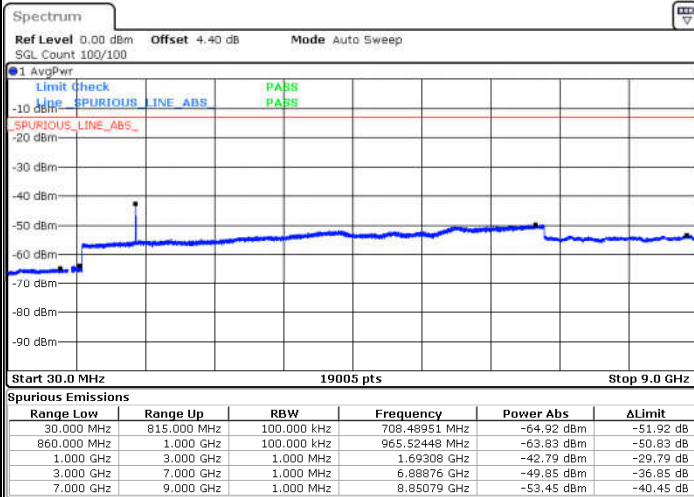

Date: 16.APR.2018 11:06:14

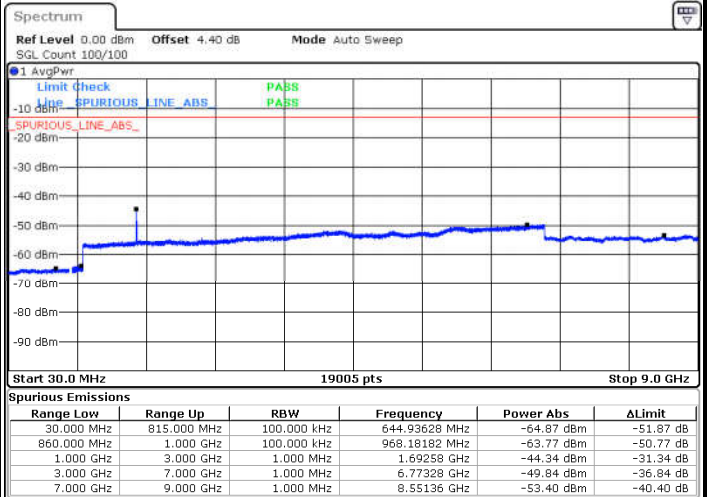

Date: 16.APR.2018 11:07:08



LTE Band 5 / 5MHz

Lowest Channel / QPSK

Lowest Channel / 16QAM

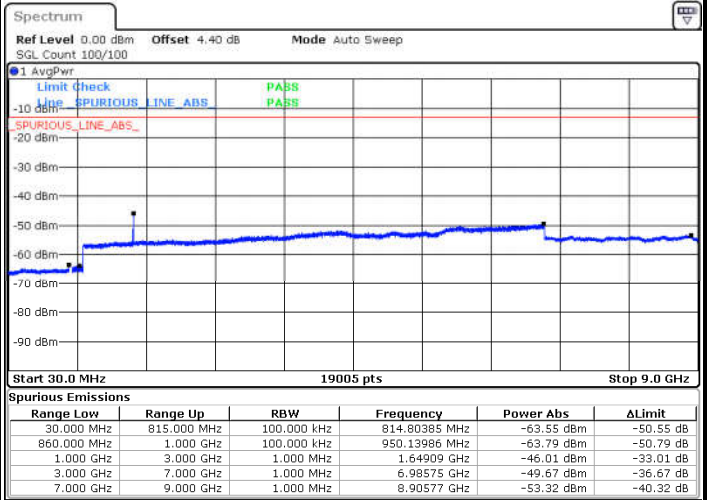
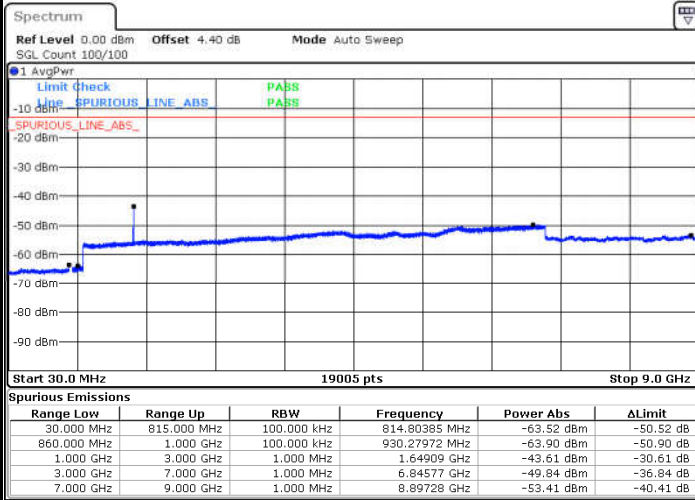

Date: 16.APR.2018 11:15:16

Date: 16.APR.2018 11:16:09

Middle Channel / QPSK

Middle Channel / 16QAM

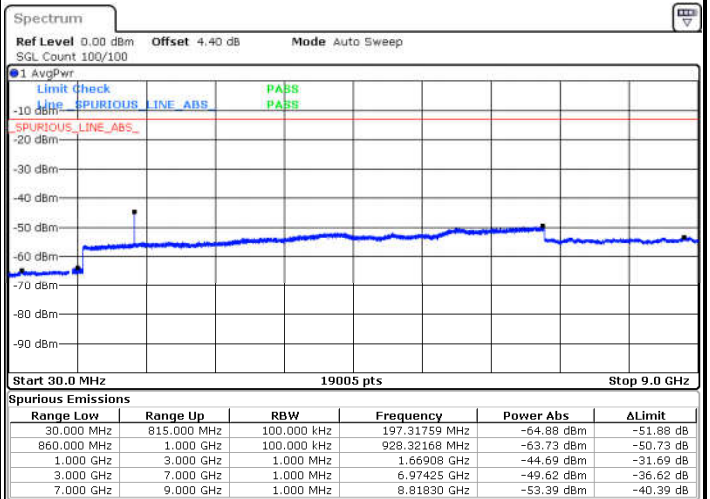
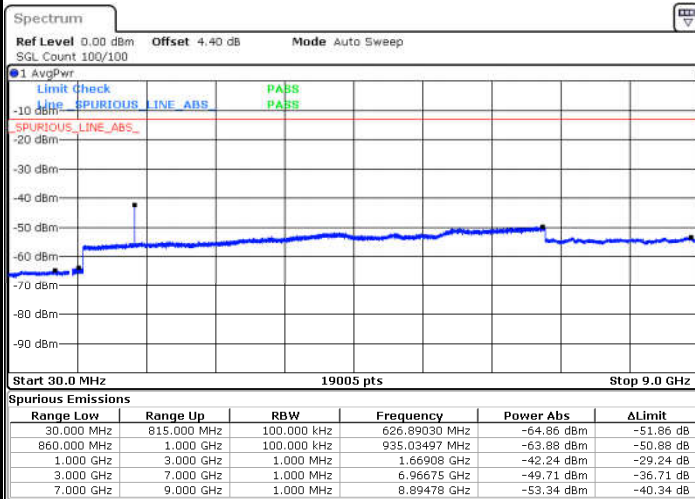

Date: 16.APR.2018 11:17:43

Date: 16.APR.2018 11:18:36



LTE Band 5 / 5MHz

Highest Channel / QPSK

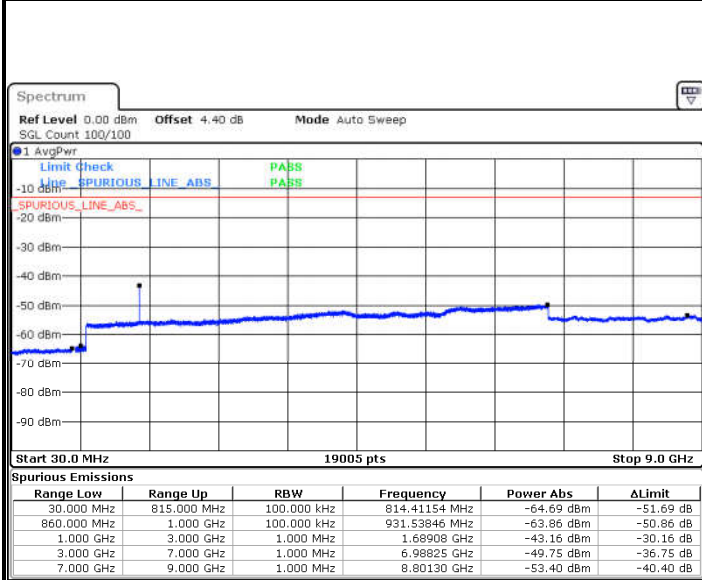

Date: 16.APR.2018 11:26:44

Highest Channel / 16QAM

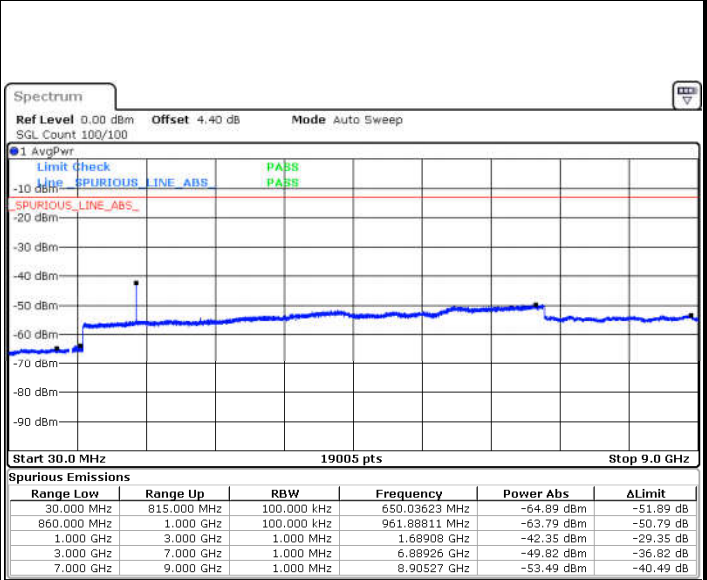

Date: 16.APR.2018 11:27:38

LTE Band 5 / 10MHz

Lowest Channel / QPSK

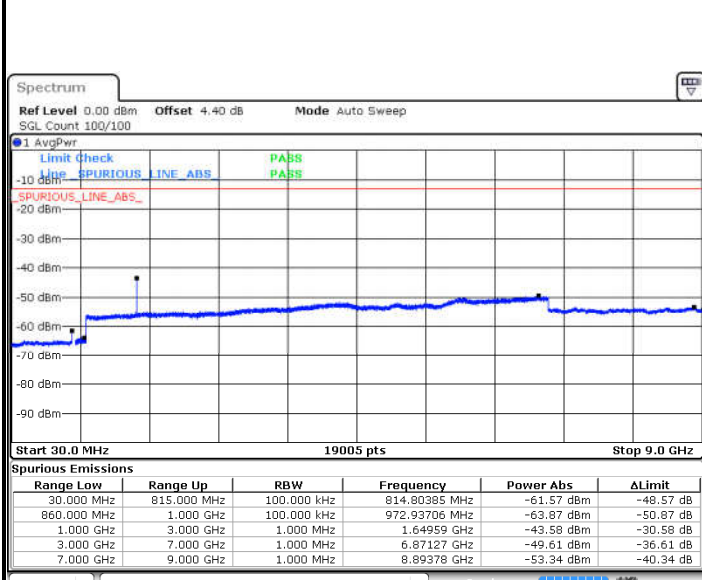

Date: 16.APR.2018 11:35:46

Lowest Channel / 16QAM

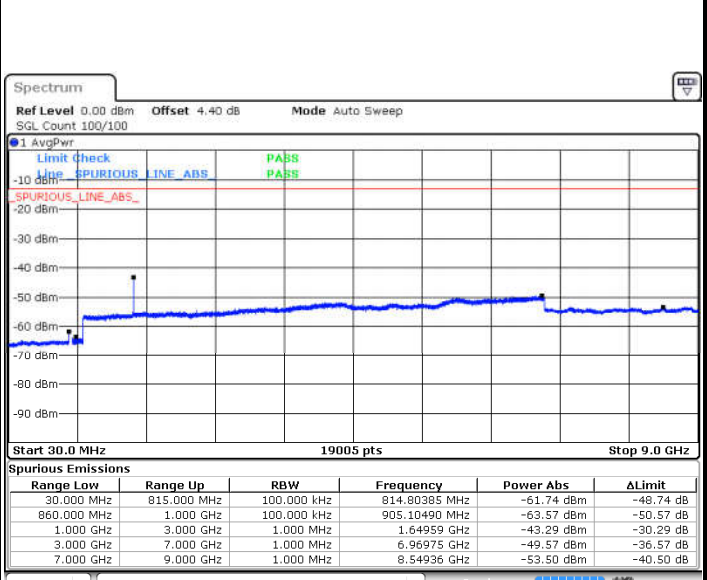

Date: 16.APR.2018 11:36:40



LTE Band 5 / 10MHz

Middle Channel / QPSK

Middle Channel / 16QAM

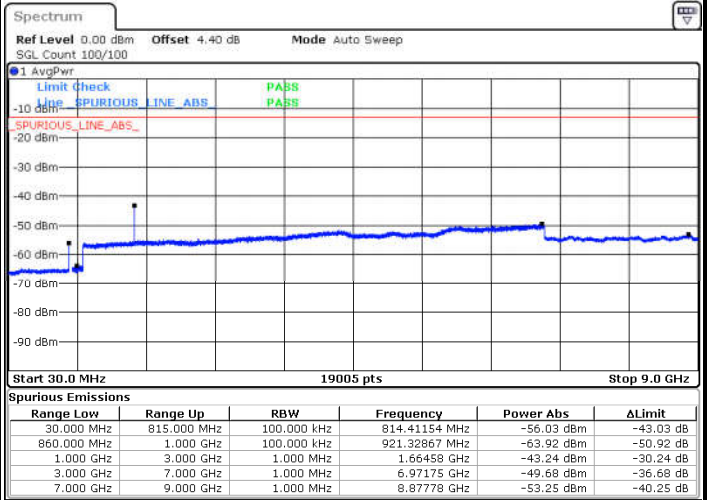
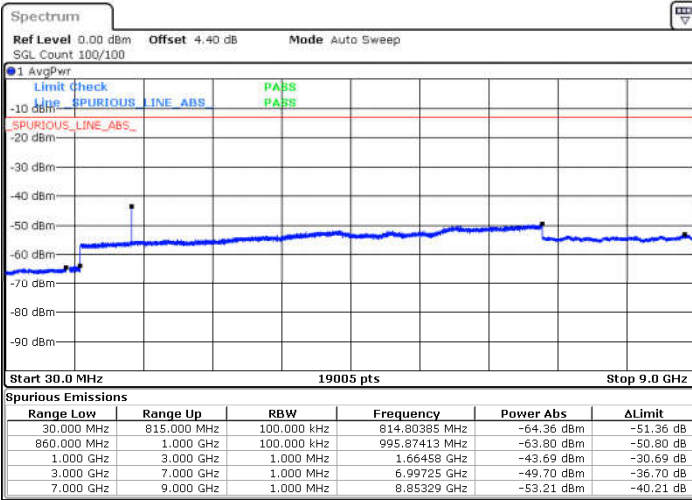

Date: 16.APR.2018 11:38:13

Date: 16.APR.2018 11:39:06

Highest Channel / QPSK

Highest Channel / 16QAM

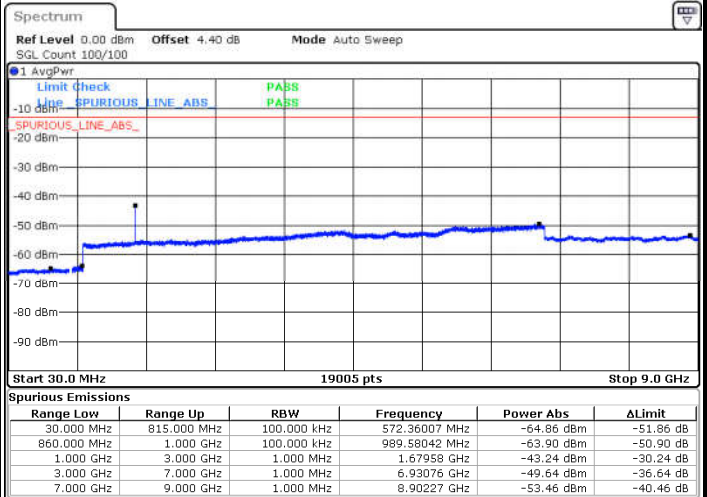
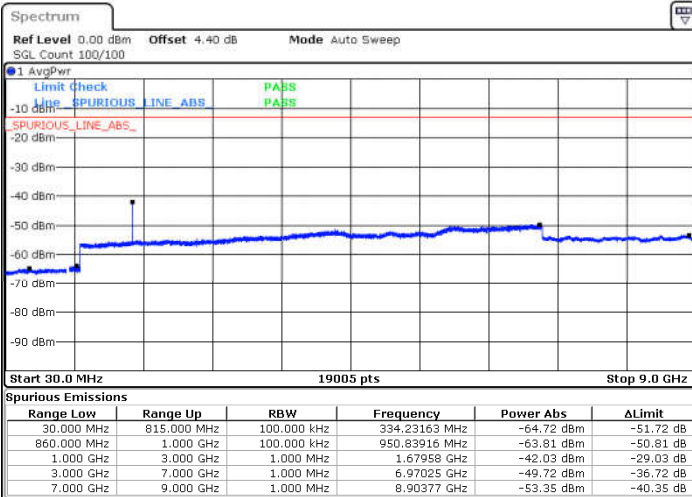

Date: 16.APR.2018 11:47:14

Date: 16.APR.2018 11:48:08



Frequency Stability

Test Conditions		LTE Band 5 (QPSK) / Middle Channel	Limit
Temperature (°C)	Voltage (Volt)	BW 10MHz	2.5ppm
		Deviation (ppm)	Result
50	Normal Voltage	0.0051	PASS
40	Normal Voltage	0.0061	
30	Normal Voltage	0.0032	
20(Ref.)	Normal Voltage	0.0000	
10	Normal Voltage	0.0048	
0	Normal Voltage	0.0059	
-10	Normal Voltage	0.0047	
-20	Normal Voltage	0.0018	
-30	Normal Voltage	0.0054	
20	Maximum Voltage	0.0023	
20	Normal Voltage	0.0050	
20	Battery End Point	0.0005	

Note: Normal Voltage =3.82V. ; Battery End Point (BEP) =3.6 V. ; Maximum Voltage =4.35 V.



Appendix B. Test Results of Radiated Test

Radiated Spurious Emission

LTE Band 5 / 10MHz / QPSK / RB Size 1 Offset 0								
Channel	Frequency (MHz)	ERP (dBm)	Limit (dBm)	Over Limit (dB)	S.G. Power (dBm)	TX Cable loss (dB)	TX Antenna Gain (dBi)	Polarization (H/V)
Middle	1664	-57.63	-13	-44.63	-59.54	1.14	5.20	H
	2496	-40.75	-13	-27.75	-43.38	1.12	5.90	H
	3327	-63.84	-13	-50.84	-67.05	1.34	6.70	H
	1664	-54.15	-13	-41.15	-56.06	1.14	5.20	V
	2496	-46.10	-13	-33.10	-48.73	1.12	5.90	V
	3327	-64.15	-13	-51.15	-67.36	1.34	6.70	V

Remark: Spurious emissions within 30-1000MHz were found more than 20dB below limit line.

