



中国认可  
国际互认  
检测  
TESTING  
CNAS L0310



## FCC HAC (RF) Compliance Test Report

Product Name: Smart Phone

Model: FRD-L24

Report No.: SYBH(Z-HAC)20171223016001-H1

FCC ID.: QISFRD-L24

	APPROVED (Lab Manager)	PREPARED (Test Engineer)
BY	<i>Wei Huanbin</i>	<i>Deng Zhao</i>
DATE	2018-02-27	2018-02-27

**Reliability Laboratory of Huawei Technologies Co., Ltd.**

**(Global Compliance and Testing Center of Huawei Technologies Co., Ltd)**

Administration Building, Headquarters of Huawei Technologies Co., Ltd., Bantian, Longgang  
District, Shenzhen, 518129, P.R.C  
Tel: +86 755 28780808 Fax: +86 755 89652518

※ ※ **Notice** ※ ※

1. The laboratory has passed the accreditation by China National Accreditation Service for Conformity Assessment (CNAS). The accreditation number is L0310.
2. The laboratory has passed the accreditation by The American Association for Laboratory Accreditation (A2LA). The accreditation number is #2174.01 & 2174.02 & 2174.03
3. The laboratory (Reliability Lab of Huawei Technologies Co., Ltd) is also named “Global Compliance and Testing Center of Huawei Technologies Co., Ltd”, the both names have coexisted since 2009.
4. The test report is invalid if not marked with the signatures of the persons responsible for preparing and approving the test report.
5. The test report is invalid if there is any evidence of erasure and/or falsification.
6. The test report is only valid for the test samples.
7. Content of the test report, in part or in full, cannot be used for publicity and/or promotional purposes without prior written approval from the laboratory.

## Table of Contents

1	General Information.....	5
1.1	Statement of Compliance .....	5
1.2	ANSI C63.19-2011 limits .....	5
1.3	EUT Description .....	6
1.3.1	General Description .....	8
1.3.2	List of air interfaces/frequency bands .....	9
1.3.3	Antenna specification .....	10
1.4	Test specification(s) .....	11
1.5	Testing laboratory .....	11
1.6	Applicant and Manufacturer .....	11
1.7	Application details .....	11
1.8	Ambient Condition.....	11
2	HAC RF Measurement System .....	12
2.1	HAC RF Measurement Set-up.....	12
2.2	Probe description .....	13
2.3	Test Arch Phantom & Phone Positioner .....	13
2.4	WD RF Emission Measurements Reference and Plane.....	14
2.5	Test Equipment List .....	15
2.6	Measurement Uncertainty Evaluation.....	16
3	System Verification Procedure .....	17
3.1	System Check.....	17
3.2	Validation Result .....	17
3.3	Modulation Interference Factor.....	18
4	HAC Measurement Procedure .....	19
5	HAC Test Configuration .....	20
5.1	General Description .....	20
5.2	GSM Test Configuration .....	20
5.3	UMTS Test Configuration .....	20
5.4	LTE Test Configuration.....	20
6	HAC RF Measurement Results .....	21
6.1	Low-power Exemption Conclusions.....	21
6.2	E-Field Emission Results .....	21
	Appendix A. System Check Plots .....	22
	Appendix B. HAC RF Measurement Plots.....	22
	Appendix C. Calibration Certificate.....	22
	Appendix D. Photo documentation .....	22
	Appendix E. MIF Specification documentation.....	22

※ ※ **Modified History** ※ ※

REV.	DESCRIPTION	ISSUED DATE	REMARK
Rev.1.0	Initial Test Report Release	2018-02-27	Deng Zhao

# 1 General Information

## 1.1 Statement of Compliance

The M-rating of Hearing-Aid Compatibility (HAC) found during testing for FRD-L24 are as below Table 1. So the M-rating of FRD-L24 is **M4**.

Band	HAC RF Emission Test result*		M-rating
<b>GSM850</b>	E-Field dB(V/m)	36.78	M4
<b>GSM1900</b>	E-Field dB(V/m)	25.62	M4
<b>UMTS Band 2</b>	E-Field dB(V/m)	/	M4
<b>UMTS Band 4</b>	E-Field dB(V/m)	/	M4
<b>UMTS Band 5</b>	E-Field dB(V/m)	/	M4
<b>LTE Band 2</b>	E-Field dB(V/m)	/	M4
<b>LTE Band 4</b>	E-Field dB(V/m)	/	M4
<b>LTE Band 5</b>	E-Field dB(V/m)	/	M4
<b>LTE Band 7</b>	E-Field dB(V/m)	/	M4
<b>LTE Band 12</b>	E-Field dB(V/m)	/	M4
<b>LTE Band 17</b>	E-Field dB(V/m)	/	M4

Table 1: Summary of test result

Note:

1) This portable wireless equipment has been shown to be hearing-aid compatible under the above rated category, specified in ANSI/IEEE Std.C63.19-2011 and had been tested in accordance with the specified measurement procedures, Hear-Aid Compatibility is based on the assumption that all production units will be designed electrically identical to the device tested in this report. Test results reported herein relate only to the item(s) tested and are for North American Bands only.

2) \*- HAC RF Emission Test for UMTS&LTE modes are exempted according to ANSI C63.19-2011 and HAC RF Emission rating is M4 (Refer to Section 6.1 for details).

## 1.2 ANSI C63.19-2011 limits

Emission Categories	E-field emissions	
	< 960 MHz	> 960 MHz
Category M1	50 to 55 dB(V/m)	40 to 45 dB(V/m)
Category M2	45 to 50 dB(V/m)	35 to 40 dB(V/m)
Category M3	40 to 45 dB(V/m)	30 to 35 dB(V/m)
Category M4	<40 dB(V/m)	<30 dB(V/m)

Table 2: Telephone near-field categories in linear units

### 1.3 EUT Description

Device Information:			
Product Name:	Smart Phone		
Model:	FRD-L24		
FCC ID:	QISFRD-L24		
SN:	1#:7ECDU17C20000064 2#:7ECDU17C20000122		
Device Type :	Portable device		
Exposure Category:	Uncontrolled environment / general population		
Device Phase:	Identical Prototype		
Hardware Version :	HL1FRDL04M		
Software Version :	FRD-L24C567B100		
Antenna Type :	Internal		
Others Accessories	Headset		
Device Operating Configurations:			
Supporting Mode(s)	GSM850/1900, UMTS Band 2/4/5, LTE Band 2/4/5/7/12/17, WiFi 2.4G/5G;BT		
Test Modulation	GSM(GMSK/8PSK), UMTS(QPSK), LTE(QPSK/16QAM)		
HSDPA UE category	14		
HSUPA UE category	6		
DC-HSDPA UE category	24		
Operating Frequency Range(s)	Band	Tx (MHz)	Rx (MHz)
	GSM850	824-849	869-894
	GSM1900	1850-1910	1930-1990
	UMTS Band 2	1850-1910	1930-1990
	UMTS Band 4	1710-1755	2110-2155
	UMTS Band 5	824 - 849	869 - 894
	LTE Band 2	1850-1910	1930-1990
	LTE Band 4	1710-1755	2110-2155
	LTE Band 5	824-849	869-894
	LTE Band 7	2500-2570	2620-2690
	LTE Band 12	699-716	729-746
	LTE Band 17	704-716	734-746
	WiFi 5G	5150-5350 5470-5850	
	WiFi 2.4G	2412-2462	
BT	2402-2480		
Power Class :	4, tested with power level 5(GSM850)		
	1, tested with power level 0(GSM1900)		
	3, tested with power control "all 1"(UMTS Band 2)		
	3, tested with power control "all 1"(UMTS Band 4)		
	3, tested with power control "all 1"(UMTS Band 5)		
	3, tested with power control all Max.(LTE Band 2)		
	3, tested with power control all Max.(LTE Band 4)		
	3, tested with power control all Max.(LTE Band 5)		
	3, tested with power control all Max.(LTE Band 7)		
	3, tested with power control all Max.(LTE Band 12)		
3, tested with power control all Max.(LTE Band 17)			
Test Channels (low-mid-high) :	128-190-251(GSM850)		
	512-661-810(GSM1900)		
	9262-9400-9538(UMTS Band 2)		
	1312-1413-1513(UMTS Band 4)		
	4132-4182-4233(UMTS Band 5)		



18607-18900-19193(LTE Band 2 BW=1.4MHz)
18615-18900-19185(LTE Band 2 BW=3MHz)
18625-18900-19175(LTE Band 2 BW=5MHz)
18650-18900-19150(LTE Band 2 BW=10MHz)
18675-18900-19125(LTE Band 2 BW=15MHz)
18700-18900-19100(LTE Band 2 BW=20MHz)
19957-20175-20393(LTE Band 4 BW=1.4MHz)
19965-20175-20385(LTE Band 4 BW=3MHz)
19975-20175-20375(LTE Band 4 BW=5MHz)
20000-20175-20350(LTE Band 4 BW=10MHz)
20025-20175-20325(LTE Band 4 BW=15MHz)
20050-20175-20300(LTE Band 4 BW=20MHz)
20407-20525-19193(LTE Band 5 BW=1.4MHz)
20415-20525-19185(LTE Band 5 BW=3MHz)
20425-20525-19175(LTE Band 5 BW=5MHz)
20450-20525-19150(LTE Band 5 BW=10MHz)
20755-21100-21425(LTE Band 7 BW=5MHz)
20800-21100-21400(LTE Band 7 BW=10MHz)
20825-21100-21375(LTE Band 7 BW=15MHz)
20850-21100-21350(LTE Band 7 BW=20MHz)
23017-23095-23173(LTE Band 12 BW=1.4MHz)
23025-23095-23165(LTE Band 12 BW=3MHz)
23035-23095-23155(LTE Band 12 BW=5MHz)
23060-23095-23130(LTE Band 12 BW=10MHz)
23755-23790-23825(LTE Band 17 BW=5MHz)
23780-23790-23800(LTE Band 17 BW=10MHz)

Table 3: Device information and operating configuration

### 1.3.1 General Description

FRD-L24 is subscriber equipment in the GSM/WCDMA/LTE/CDMA system. The GSM frequency band is GSM850 and GSM900 and DCS1800 and PCS1900. The UMTS frequency band is B1 and B2 and B4 and B5 and B8. The LTE frequency band is B2 and B4 and B5 and B7 and B12 and B17. But only GSM850 and GSM1900, UMTS frequency B2 and B4 and B5, LTE frequency B2 and B4 and B5 and B7 and B12 and B17 bands test data included in this report. The Mobile Phone implements such functions as RF signal receiving/transmitting, LTE/HSPA/UMTS and GSM/GPRS/EDGE protocol processing, voice, video MMS service, GPS, AGPS and WIFI etc. Externally it provides one micro SD card (it can also used as SIM card interface), earphone port (to provide voice service) and one SIM card interface. FRD-L24 is single SIM smart phone. It also provides Bluetooth module to synchronize data between a PC and the phone, or to use the built-in modem of the phone to access the Internet with a PC, or to exchange data with other Bluetooth devices.

#### Battery information:

Name	Manufacture	Serials number	Description
Rechargeable Li-ion	Desay	NA	Battery Model: HB366481ECW Rated capacity: 2900mAh Nominal Voltage:  +3.82V Charging Voltage:  +4.40V



### 1.3.2 List of air interfaces/frequency bands

Air-Interface	Bands (MHz)	Type	C63.19 HAC tested	Simultaneous Transmitter	Name of Voice Service	Additional GSM power reduction
GSM	850	VO	Yes	WiFi/BT	CMRS Voice*	N/A
	1900	VO	Yes	WiFi/BT		N/A
	GPRS/EDGE	DT	N/A	WiFi/BT	N/A	N/A
UMTS	Band 2(1900)	VO	Yes**	WiFi/BT	CMRS Voice*	N/A
	Band 4(1750)	VO	Yes**	WiFi/BT		N/A
	Band 5(850)	VO	Yes**	WiFi/BT		N/A
	HSPA/DC-HSDPA	DT	N/A	WiFi/BT	N/A	N/A
LTE	Band 2	VD	Yes**	WiFi/BT	VoLTE*	N/A
	Band 4	VD	Yes**	WiFi/BT		N/A
	Band 5	VD	Yes**	WiFi/BT		N/A
	Band 7	VD	Yes**	WiFi/BT		N/A
	Band 12	VD	Yes**	WiFi/BT		N/A
	Band 17	VD	Yes**	WiFi/BT		N/A
WiFi	2450	DT	N/A	GSM/UMTS/LTE	N/A	N/A
	5200 (U-NII-1)	DT	N/A	GSM/UMTS/LTE		N/A
	5300 (U-NII-2A)	DT	N/A	GSM/UMTS/LTE		N/A
	5500 (U-NII-2C)	DT	N/A	GSM/UMTS/LTE		N/A
	5800 (U-NII-3)	DT	N/A	GSM/UMTS/LTE		N/A
BT	2450	DT	N/A	GSM/UMTS/LTE	N/A	N/A

Note:

- 1) \* - Ref Lev in accordance with 7.4.2.1 of ANSI C63.19-2011 and the July 2012 VoLTE interpretation.
- 2) \*\*- Evaluated for MIF and low-power exemption according to ANSI C63.19-2011.
- 3) The device supports VoLTE.
- 4) The device does not support Wi-Fi calling or other pre-installed OTT voice services that are not defined in ANSI C63.19-2011 .

### 1.3.3 Antenna specification

The device has one 2G/3G/4G Tx antenna (Main Antenna) and one WIFI/BT Tx antenna. The 2G/3G/4G Second Antenna does not support Tx function.

The location of the antennas inside the device is shown as below picture(Unit:mm):

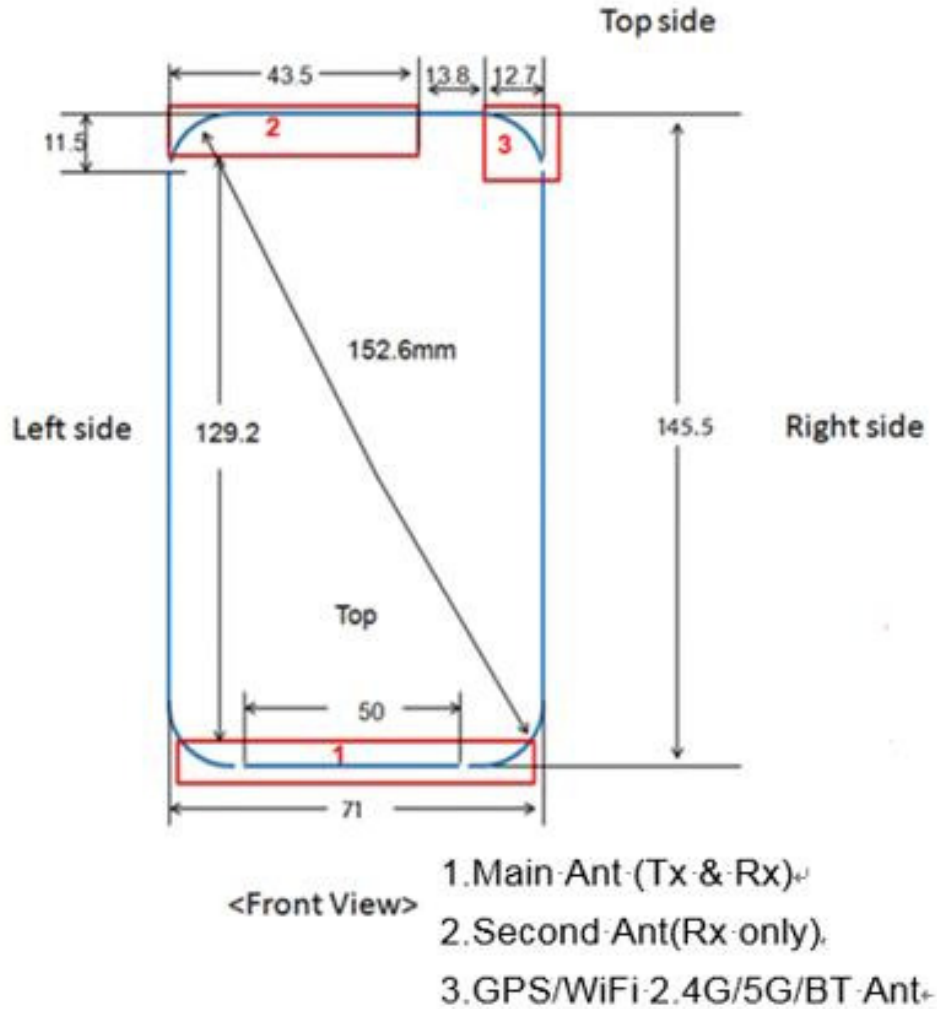

#### 1.4 Test specification(s)

ANSI C63.19-2011	American National Standard for Methods of Measurement of Compatibility between Wireless Communication Devices and Hearing Aids
KDB 285076 D01	HAC Guidance v05
KDB 285076 D02	T-Coil testing v03
KDB 285076 D03	HAC FAQ v01
CFR 47 FCC Part 20	§ 20.19 Hearing aid-compatible mobile handsets.

#### 1.5 Testing laboratory

Test Site	Reliability Laboratory of Huawei Technologies Co., Ltd.
Test Location	Section G1, Huawei Base Bantian, Longgang District, Shenzhen 518129, P.R. China
Telephone	+86-755-28785513
Fax	+86-755-36834474
State of accreditation	The Test laboratory (area of testing) is accredited according to ISO/IEC 17025. CNAS Registration number: L0310 A2LA TESTING CERT #2174.01 & 2174.02 & 2174.03

#### 1.6 Applicant and Manufacturer

Company Name	HUAWEI TECHNOLOGIES CO., LTD
Address	Administration Building, Headquarters of Huawei Technologies Co., Ltd., Bantian, Longgang District, Shenzhen, 518129, P.R.C

#### 1.7 Application details

Start Date of test	2018-02-06
End Date of test	2018-02-26

#### 1.8 Ambient Condition

Ambient temperature	18°C – 25°C
Relative Humidity	30% – 70%

## 2 HAC RF Measurement System

### 2.1 HAC RF Measurement Set-up

These measurements are performed using the DASY5 NEO automated dosimetric assessment system. It is made by Schmid & Partner Engineering AG (SPEAG) in Zurich, Switzerland. It consists of high precision robotics system (Stäubli), robot controller, Lenovo Intel Core i5 3.1 GHz computer, near-field probe, probe alignment sensor. The robot is a six-axis industrial robot performing precise movements. A cell controller system contains the power supply, robot controller, teach pendant (Joystick), and remote control, is used to drive the robot motors. The PC consists of the Lenovo Intel Core i5 3.1 GHz computer with Windows 7 system and HAC Measurement Software DASY5 NEO, A/D interface card, monitor, mouse, and keyboard. The Stäubli Robot is connected to the cell controller to allow software manipulation of the robot. A data acquisition electronic (DAE) circuit performs the signal amplification, signal multiplexing, AD-conversion, offset measurements, mechanical surface detection, collision detection, etc. is connected to the Electro-optical coupler (EOC). The EOC performs the conversion from the optical into digital electric signal of the DAE and transfers data to the PC plug-in card.

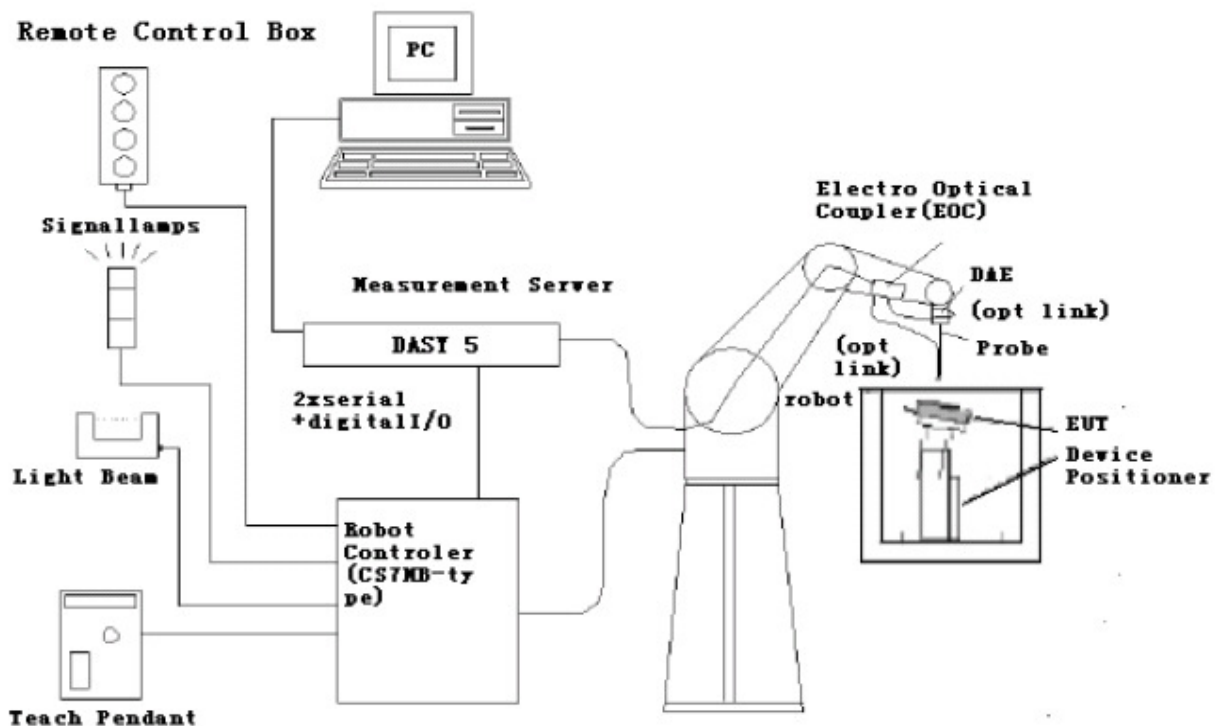
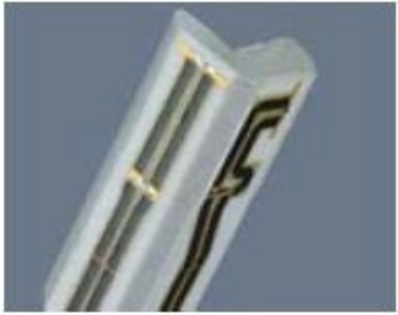

Fig. 1 HAC Test Measurement Set-up

The DAE4 consists of a highly sensitive electrometer-grade preamplifier with auto-zeroing, a channel and gain-switching multiplexer, a fast 16 bit AD-converter and a command decoder and control logic unit. Transmission to the PC-card is accomplished through an optical downlink for data and status information and an optical uplink for commands and clock lines. The mechanical probe mounting device includes two different sensor systems for frontal and sidewise probe contacts. They are also used for mechanical surface detection and probe collision detection. The robot uses its own controller with a built in VME-bus computer.

## 2.2 Probe description

### E-Field Probe Description

Construction	One dipole parallel, two dipoles normal to probe axis Built-in shielding against static charges PEEK enclosure material	 <p>[ER3DV6]</p>
Calibration	In air from 100 MHz to 3.0 GHz (absolute accuracy $\pm 6.0\%$ , $k=2$ )	
Frequency	40 MHz to > 6 GHz (can be extended to < 20 MHz) Linearity: $\pm 0.2$ dB (100 MHz to 3 GHz)	
Directivity	$\pm 0.2$ dB in air (rotation around probe axis) $\pm 0.4$ dB in air (rotation normal to probe axis)	
Dynamic range	2 V/m to > 1000 V/m; Linearity: $\pm 0.2$ dB	
Dimensions	Overall length: 330 mm (Tip: 16 mm) Tip diameter: 8 mm (Body: 12 mm) Distance from probe tip to dipole centers: 2.5 mm The closest part of the sensor element is 1.1mm closer to the tip	
Application	General near-field measurements up to 6 GHz Field component measurements Fast automatic scanning in phantoms	

## 2.3 Test Arch Phantom & Phone Positioner

The Test Arch phantom should be positioned horizontally on a stable surface. Reference markings on the Phantom allow the complete setup of all predefined phantom positions and measurement grids by manually teaching three points in the robot. It enables easy and well defined positioning of the phone and validation dipoles as well as simple teaching of the robot (Dimensions: 370 x 370 x 370 mm).

The Phone Positioner supports accurate and reliable positioning of any phone with effect on near field  $< \pm 0.5$  dB.

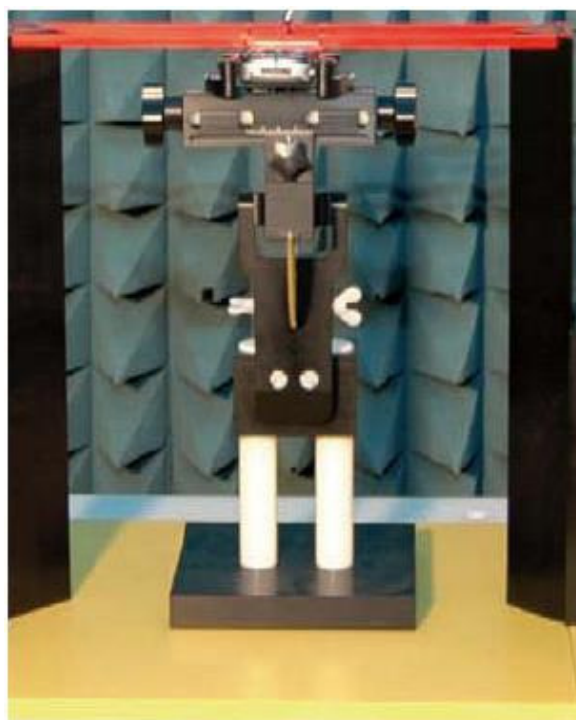

**Fig. 2 HAC Phantom & Device Holder**

## 2.4 WD RF Emission Measurements Reference and Plane

Figure 3 illustrates the references and reference plane that shall be used in the WD emissions measurement.

- The grid is 5 cm by 5 cm area that is divided into 9 evenly sized blocks or sub-grids.
- The grid is centered on the audio frequency output transducer of the WD (speaker or T-coil).
- The grid is located by reference to a reference plane. This reference plane is the planar area that contains the highest point in the area of the WD that normally rests against the user's ear
- The measurement plane is located parallel to the reference plane and 15 mm from it, out from the phone. The grid is located in the measurement plane.



Fig. 3 WD reference and plane for RF emission measurements

## 2.5 Test Equipment List

This table gives a complete overview of the HAC measurement equipment  
Devices used during the test described are marked ☒

	Manufacturer	Device	Type	Serial number	Date of last calibration	Valid period
☒	SPEAG	Dosimetric E-Field Probe	ER3DV6	2441	2017-11-17	One year
☒	SPEAG	835 MHz Dipole	CD835V3	1114	2017-11-22	Three years
☒	SPEAG	1880 MHz Dipole	CD1880V3	1100	2017-11-22	Three years
☒	SPEAG	Data acquisition electronics	DAE4	1236	2017-07-21	One year
☒	SPEAG	HAC Test Arch	SD HAC P01 BA	1053	NCR	NCR
☒	SPEAG	Software	DASY 5	N/A	NCR	NCR
☒	Agilent	Signal Generator	N5181A	MY50145341	2017-12-08	One year
☒	MINI-CIRCUITS	Amplifier	ZHL-42W	QA0746001	NCR	NCR
☒	AR	Directional Coupler	DC7144M1	311190	2017-05-26	One year
☒	R & S	Power Meter	NRP	100740	2017-07-17	One year
☒	R & S	Power Meter Sensor	NRP-Z11	106288	2017-07-07	One year
☒	Agilent	Power Meter	E4417A	MY45100027	2017-04-10	One year
☒	Agilent	Power Meter Sensor	E9321A	MY54130007	2017-04-10	One year
☒	R & S	Universal Radio Communication Tester	CMW 500	158850	2017-06-13	One year

Note:

- 1) Per KDB865664D01 requirements for dipole calibration, the test laboratory has adopted three-year extended calibration interval. Each measured dipole is expected to evaluate with the following criteria at least on annual interval in Appendix C.
  - a) There is no physical damage on the dipole;
  - b) System check with specific dipole is within 25% of calibrated value;
  - c) The most recent return-loss result, measured at least annually, deviates by no more than 20% from the previous measurement.
  - d) The most recent measurement of the real or imaginary parts of the impedance, measured at least annually is within 5Ω from the previous measurement.



## 2.6 Measurement Uncertainty Evaluation

Uncertainty Component	Uncertainty Value	Probability Distribution	Divisor	ci (E)	Standard Uncertainty (E)
<b>Measurement System</b>					
Probe calibration	± 5.1%	Normal	1	1	± 5.1%
Axial isotropy	± 4.7%	Rectangular	√3	1	± 2.7%
Sensor Displacement	± 16.5%	Rectangular	√3	1	± 9.5%
Boundary Effects	± 2.4%	Rectangular	√3	1	± 1.4%
Phantom Boundary Effect	± 7.2%	Rectangular	√3	1	± 4.1%
Linearity	± 4.7%	Rectangular	√3	1	± 2.7%
Scaling with PMR calibration	± 10.0%	Rectangular	√3	1	± 5.8%
System Detection Limit	± 1.0%	Rectangular	√3	1	± 0.6%
Readout Electronics	± 0.3%	Normal	1	1	± 0.3%
Response Time	± 0.8%	Rectangular	√3	1	± 0.5%
Integration Time	± 2.6%	Rectangular	√3	1	± 1.5%
RF Ambient Conditions	±3.0%	Rectangular	√3	1	± 1.7%
RF Reflections	±12.0%	Rectangular	√3	1	± 6.9%
Probe positioner	± 1.2%	Rectangular	√3	1	± 0.7%
Probe positioning	± 4.7%	Rectangular	√3	1	± 2.7%
Extrap. and Interpolation	± 1.0%	Rectangular	√3	1	± 0.6%
<b>Test Sample Related</b>					
Device Positioning Vertical	± 4.7%	Rectangular	√3	1	± 2.7%
Device Positioning Lateral	± 1.0%	Rectangular	1	1	± 0.6%
Device Holder and Phantom	± 2.4%	Rectangular	√3	1	± 1.4%
Power Drift	± 5.0%	Rectangular	√3	1	± 2.9%
<b>Phantom and Set-up</b>					
Phantom Thickness	± 2.4%	Rectangular	√3	1	± 1.4%
<b>Combined Std. Uncertainty</b>					<b>± 16.3%</b>
<b>Expanded Std. Uncertainty on Power</b>					<b>± 32.6%</b>
<b>Expanded Std. Uncertainty on Field</b>					<b>± 16.3%</b>

Table 4: Measurement uncertainties

Note: Worst-Case uncertainty budget for HAC free field assessment according to ANSI C63.19. The budget represents a worst case analysis. For specific tests and configurations, the uncertainty could be considerably smaller.



### 3 System Verification Procedure

#### 3.1 System Check

Place a dipole antenna meeting the requirements given in ANSI C63.19-2011 in the position normally occupied by the WD. The dipole antenna serves as a known source for an electrical and magnetic output. Position the E-field probe so that the following occurs:

- The probes and their cables are parallel to the coaxial feed of the dipole antenna
- The probe cables and the coaxial feed of the dipole antenna approach the measurement area from opposite directions
- The center point of the probe element(s) are 15 mm from the closest surface of the dipole elements.

Scan the length of the dipole with the E-field probe and record the two maximum values found near the dipole ends. Average the two readings and compare the reading to the expected value in the calibration certificate or the expected value in this standard.

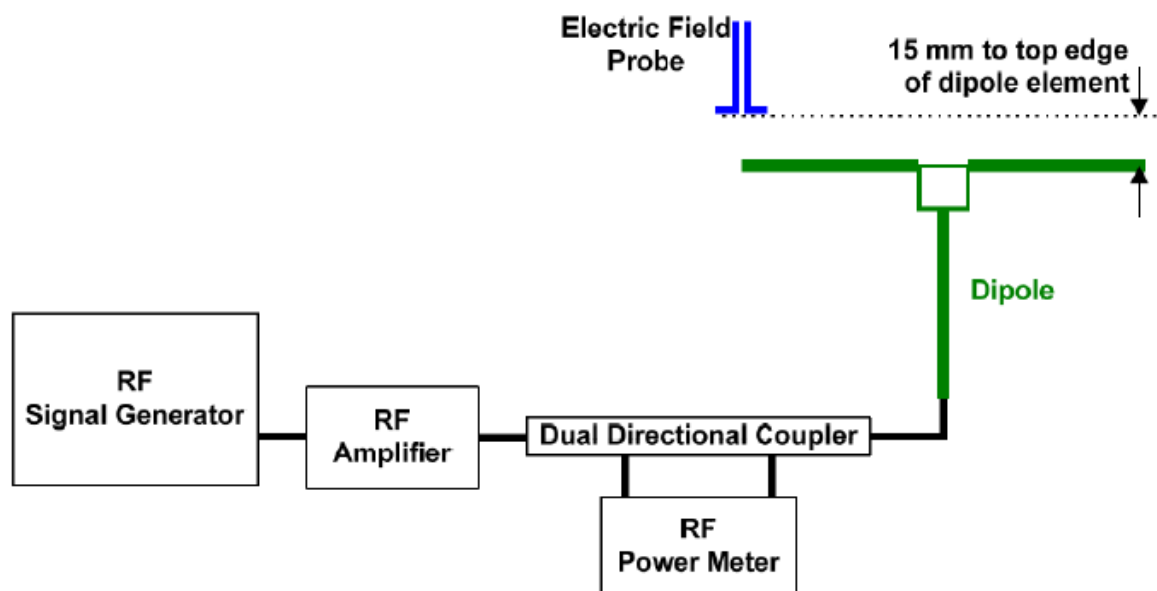

Fig. 4 Dipole Validation Setup

#### 3.2 Validation Result

Frequency (MHz)	Input Power (mW)	E-Field Value 1 (V/m)	E-Field Value 2 (V/m)	Averaged Measured <sup>1</sup> Value(V/m)	Target <sup>2</sup> Value (V/m)	Deviation <sup>3</sup> (%)	Limit <sup>4</sup> (%)	Test Date
835	100	114.60	121.20	117.90	108.50	8.66%	±25%	2018-02-07
1880	100	87.66	92.78	90.20	88.50	1.94%	±25%	2018-02-07

<sup>1</sup> Please refer to the attachment for detailed measurement data and plot.

<sup>2</sup> Target value is provided by SPEAD in the calibration certificate of specific dipoles.

<sup>3</sup> Deviation (%) = 100 \* (Measured value minus Target value) divided by Target value.

<sup>4</sup> ANSI C63.19 requires values within ± 25% are acceptable, of which 12% is deviation and 13% is measurement uncertainty. Values independently validated for the dipole actually used in the measurements should be used, when available.

### 3.3 Modulation Interference Factor

The HAC Standard ANSI C63.19-2011 defines a new scaling using the Modulation Interference Factor(MIF) which replaces the need for the Articulation Weighting Factor(AWF) during the evaluation and is applicable to any modulation scheme.

The Modulation Interference Factor(MIF, in dB) is added to the measured average E-field (in dB V/m) and converts it to the RF Audio Interference level(in dB V/m). This level considers the audible amplitude modulation components in the RF E-field. CW fields without amplitude modulation are assumed to not interfere with the hearing aid electronics.Modulations without time slots and low fluctuations at low frequencies have low MIF values.TDMA modulations with narrow transmission and repetition rates of few 100 Hz have high MIF values and give similar classifications as ANSI C63.19-2007.

ER3D E-Field probes have a bandwidth <10 kHz and can therefore not evaluate the RF envelope in the full audio band. DASY52 is therefore using the “indirect” measurement method according to ANSI C63.19-2011 which is the primary method. These near field probes read the averaged E-field measurement. Especially for the new high peak-to-average(PAR) signal types, the probes shall be linearized by probe modulation response(PMR) calibration in order to not overestimate the field reading. The evaluation method or the MIF is defined in ANSI C63.19-2011 section D.7. An RMS demodulated RF signal is fed to a spectral filter(similar to an A weighting filter) and forwarded to a temporal filter acting as a quasi-peak detector. The averaged output of these filtering is called to a 1 kHz 80% AM signal as reference. MIF measurement requires additional instrumentation and is not well suited for evaluation by the end user with reasonable uncertainty.It may alternatively be determined through analysis and simulation, because it is constraint and characteristic for a communication signal. DASY52 uses well defined signals for PMR calibration. The MIF of these signals has been determined by simulation and is automatically applied.

MIF values applied in this test report were provided by the HAC equipment provider, SPEAG. The data included in this report are for the worst case operating modes. The UIDs used are listed below:

UID	Communication System Name	MIF(dB)
10011-CAB	UMTS-FDD (WCDMA)	-27.23
10021-DAC	GSM-FDD (TDMA, GMSK)	3.63
10170-CAD	LTE-FDD (SC-FDMA, 1RB, 20MHz, 16QAM)	-9.76
10176-CAE	LTE-FDD (SC-FDMA, 1RB, 10MHz, 16QAM)	-9.76

The MIF measurement uncertainty is estimated as follows, declared by the HAC equipment provider, SPEAG, for modulation frequencies from slotted waveforms with fundamental frequency and at least 2 harmonics within 10 kHz:

- i) 0.2 dB for MIF: -7 to +5 dB
- ii) 0.5 dB for MIF: -13 to +11 dB
- iii) 1 dB for MIF: > -20 dB

## 4 HAC Measurement Procedure

### The evaluation was performed with the following procedure:

- a) Confirm the proper operation of the field probe, probe measurement system, and other instrumentation and the positioning system.
- b) Position the WD in its intended test position.
- c) Set the WD to transmit a fixed and repeatable combination of signal power and modulation characteristic that is representative of the worst case (highest interference potential) encountered in normal use. Transiently occurring start-up, changeover, or termination conditions, or other operations likely to occur less than 1% of the time during normal operation, may be excluded from consideration.
- d) The center subgrid shall be centered on the T-Coil mode perpendicular measurement point or the acoustic output, as appropriate. Locate the field probe at the initial test position in the 50 mm by 50 mm grid, which is contained in the measurement plane, refer to illustrated in Figure 3. If the field alignment method is used, align the probe for maximum field reception.
- e) Record the reading at the output of the measurement system.
- f) Scan the entire 50 mm by 50 mm region in equally spaced increments and record the reading at each measurement point. The distance between measurement points shall be sufficient to assure the identification of the maximum reading.
- g) Identify the five contiguous subgrids around the center subgrid whose maximum reading is the lowest of all available choices. This eliminates the three subgrids with the maximum readings. Thus, the six areas to be used to determine the WD's highest emissions are identified.
- h) Identify the maximum reading within the nonexcluded subgrids identified in step g).
- i) Convert the maximum reading identified in step h) to RF audio interference level, in, V/m, by taking the square root of the reading and then dividing it by the measurement system transfer function, established in 5.5.1.1. Convert the result to dB(V/m) by taking the base-10 logarithm and multiplying it by 20.

### Indirect measurement method

Replacing step i) of 5.5.1.2, the RF audio interference level in dB(V/m) is obtained by adding the MIF (in dB) to the maximum steady-state rms field-strength reading, in dB(V/m), from step h). Use this result to determine the category rating.

- j) Compare this RF audio interference level with the categories in Clause 8 and record the resulting WD category rating.
- k) For the T-Coil mode M-rating assessment, determine whether the chosen perpendicular measurement point is contained in an included subgrid of the first scan. If so, then a second scan is not necessary. The first scan and resultant category rating may be used for the T-Coil mode M rating. Otherwise, repeat step a) through step i), with the grid shifted so that it is centered on the perpendicular measurement point. Record the WD category rating.

## 5 HAC Test Configuration

### 5.1 General Description

The phone was tested in all normal configurations for the ear use. The EUT is mounted in the device holder equivalent as for classic dosimeter measurements. The acoustic output of the EUT shall coincide with the center point of the area formed by the dielectric wire and the middle bar of the arch's top frame. The EUT shall be moved vertically upwards until it touches the frame. The fine adjustment is possible by sliding the complete. The EUT holder is on the yellow base plate of the Test Arch phantom. These test configurations are tested at the high, middle and low frequency channels of each applicable operating mode; for example, GSM, WCDMA(UMTS), CDMA and TDMA.

### 5.2 GSM Test Configuration

A communication link is set up with a System Simulator (SS) by air link, and a call is established. The Absolute Radiofrequency Channel Number (ARFCN) is allocated to 128, 190 and 251 in the case of GSM850, to 512, 661 and 810 in the case of GSM1900. The EUT is commanded to operate at maximum transmitting power. Using CMW500 the power level is set to "5" in HAC of GSM850, set to "0" in HAC of GSM1900.

### 5.3 UMTS Test Configuration

A communication link is set up with a System Simulator (SS) by air link, and a call is established. The Absolute Radiofrequency Channel Number (ARFCN) is allocated to 9262, 9400 and 9538 in the case of UMTS Band 2, to 1312, 1413, and 1513 in the case of UMTS Band 4, to 4132, 4182 and 4233 in the case of UMTS Band 5. The EUT is commanded to operate at maximum transmitting power. Using CMW500 the power level is set to to all up bits for UMTS bands.

### 5.4 LTE Test Configuration

A communication link is set up with a System Simulator (SS) by air link, and a call is established. The CMW500 WideBand Radio Communication Tester was used for LTE output power measurements and HAC testing. Closed loop power control was used so the UE transmits with maximum output power during testing. Test were performed with the same number of RB and RB offsets transmitting on all TTI frames(Maximum TTI). The EUT is commanded to operate at maximum transmitting power.

## 6 HAC RF Measurement Results

### 6.1 Low-power Exemption Conclusions

According to ANSI C63.19-2011, a RF air interface technology of a device is exempt from testing when its average antenna input power plus its MIF is  $\leq 17$  dBm for any of its operation modes.

Air Interface	Maxium Average Power(dBm)	MIF(dB)	Total (Power + MIF,dB)	C63.19 HAC RF testing required
GSM850	34.00	3.63	37.63	Yes
GSM1900	31.00	3.63	34.63	Yes
UMTS Band 2	25.00	-27.23	-2.23	No
UMTS Band 4	25.00	-27.23	-2.23	No
UMTS Band 5	25.50	-27.23	-1.73	No
LTE Band 2	24.00	-9.76	14.24	No
LTE Band 4	23.50	-9.76	13.74	No
LTE Band 5	24.00	-9.76	14.24	No
LTE Band 7	23.00	-9.76	13.24	No
LTE Band 12	24.50	-9.76	14.74	No
LTE Band 17	25.00	-9.76	15.24	No

Table 5: Low-power Exemption calculation

Per ANSI C63.19-2011, HAC RF Emission testing for this device is required only for GSM voice modes. All the other applicable air interfaces are exempt from HAC RF testing.

### 6.2 E-Field Emission Results

Band	Test Mode	Test channel /Freq.(MHz)	MIF (dB)	RF audio interference level [dB(V/m)]	Power Drift (dB)	FCC Limit [dB(V/m)]	Margin to the next lower rating(dB)	M-Rating
GSM850	GSM	251/848.8	3.63	36.78	-0.04	40	3.22	M4
		190/836.6	3.63	36.32	0.01	40	3.68	M4
		128/824.2	3.63	35.36	0.04	40	4.64	M4
GSM1900	GSM	810/1909.8	3.63	25.34	-0.13	30	4.66	M4
		661/1880	3.63	24.88	0.00	30	5.12	M4
		512/1850.2	3.63	25.62	-0.02	30	4.38	M4

Table 6: Test Results of E-Field Emissions.

Note:

- 1) The HAC measurement system applies MIF value onto the measured RMS E-field, which is indirect method in ANSI C63.19-2011 version, and reports the RF audio interference level.
- 2) The uncertainty is 0.2dB for MIF from -7 to +5dB, 0.5dB for MIF from -13dB to +11 dB, and 1dB for MIF ranges  $> -20$ dB. From the test results above and considering the uncertainty of MIF value, the margin is large enough and the device **M4** rating will not be changed.
- 3) UMTS&LTE bands are exempted and HAC RF Emission rating is M4 per ANSI C63.19-2011 .
- 4) The Hearing Aid mode of the software on this DUT is turned on during the test.

**Appendix A. System Check Plots**

(Pls See Appendix No.: SYBH(Z-HAC)20171223016001-H1A, total: 5 pages)

**Appendix B. HAC RF Measurement Plots**

(Pls See Appendix No.: SYBH(Z-HAC)20171223016001-H1B, total: 13 pages)

**Appendix C. Calibration Certificate**

(Pls See Appendix No.: SYBH(Z-HAC)20171223016001-H1C, total: 28 pages)

**Appendix D. Photo documentation**

(Pls See Appendix No.: SYBH(Z-HAC)20171223016001-H1D, total: 2 pages)

**Appendix E. MIF Specification documentation**

(Pls See Appendix No.: SYBH(Z-HAC)20171223016001-H1E, total: 9 pages)

---

**END**