



**SGS-CSTC Standards Technical Services Co., Ltd.  
Shenzhen Branch**

No. 1 Workshop, M-10, Middle section, Science & Technology Park,  
Shenzhen, Guangdong, China 518057

Telephone: +86 (0) 755 2601 2053  
Fax: +86 (0) 755 2671 0594  
Email: ee.shenzhen@sgs.com

Report No.: SZEM171201293901  
Page: 1 of 19

# TEST REPORT

**Application No.:** SZEM1712012939RG  
**Applicant:** Huawei Technologies Co.,Ltd  
**Address of Applicant:** Administration Building, Headquarters of Huawei Technologies Co., Ltd.,  
Bantian, Longgang District Shenzhen China  
**Manufacturer:** Huawei Technologies Co.,Ltd  
**Address of Manufacturer:** Administration Building, Headquarters of Huawei Technologies Co., Ltd.,  
Bantian, Longgang District Shenzhen China  
**Factory:** Huawei Technologies Co.,Ltd  
**Address of Factory:** Administration Building, Headquarters of Huawei Technologies Co., Ltd.,  
Bantian, Longgang District Shenzhen China  
**Equipment Under Test (EUT):**  
**EUT Name:** Smart Phone  
**Model No.:** EML-L29 ,  
**FCC ID:** QISEML-L29  
**IC ID:** 6369A-EMLL29  
**Standard(s) :** 47 CFR Part 15, Subpart E 15.407  
RSS-Gen Issue 4 Nov 2014  
RSS 247 Issue 2 Feb 2017  
**Date of Receipt:** 2018-01-05  
**Date of Test:** 2018-01-05 to 2018-01-10  
**Date of Issue:** 2018-01-22

<b>Test Result:</b>	<b>Pass*</b>
---------------------	--------------

\* In the configuration tested, the EUT complied with the standards specified above.



Keny Xu  
EMC Laboratory Manager

The manufacturer should ensure that all products in series production are in conformity with the product sample detailed in this report. If the product in this report is used in any configuration other than that detailed in the report, the manufacturer must ensure the new system complies with all relevant standards. Any mention of SGS International Electrical Approvals or testing done by SGS International Electrical Approvals in connection with, distribution or use of the product described in this report must be approved by SGS International Electrical Approvals in writing.

This document is issued by the Company subject to its General Conditions of Service printed overleaf, available on request or accessible at <http://www.sgs.com/en/Terms-and-Conditions.aspx> and, for electronic format documents, subject to Terms and Conditions for Electronic Documents at <http://www.sgs.com/en/Terms-and-Conditions/Terms-e-Documents.aspx>. Attention is drawn to the limitation of liability, indemnification and jurisdiction issues defined therein. Any holder of this document is advised that information contained hereon reflects the Company's findings at the time of its intervention only and within the limits of Client's instructions, if any. The Company's sole responsibility is to its Client and this document does not exonerate parties to a transaction from exercising all their rights and obligations under the transaction documents. This document cannot be reproduced except in full, without prior written approval of the Company. Any unauthorized alteration, forgery or falsification of the content or appearance of this document is unlawful and offenders may be prosecuted to the fullest extent of the law. Unless otherwise stated the results shown in this test report refer only to the sample(s) tested and such sample(s) are retained for 30 days only.



<b>Revision Record</b>				
<b>Version</b>	<b>Chapter</b>	<b>Date</b>	<b>Modifier</b>	<b>Remark</b>
01		2018-01-22		Original

<b>Authorized for issue by:</b>				
				
		<hr/>		
		<b>Gray Gao /Project Engineer</b>		
				
		<hr/>		
		<b>Eric Fu /Reviewer</b>		



## 2 Test Summary

Radio Spectrum Matter Part				
Item	Standard	Method	Requirement	Result
DFS: Channel Move Time	47 CFR Part 15, Subpart E 15.407 RSS-247 6.3	KDB 905462 D02 Section 7.8.3	KDB 905462 D02 Section 5.1	Pass
DFS: Channel Closing Transmission Time	47 CFR Part 15, Subpart E 15.407 RSS-247 6.3	KDB 905462 D02 Section 7.8.3	KDB 905462 D02 Section 5.1	Pass



### 3 Contents

	Page
<b>1 COVER PAGE</b> .....	<b>1</b>
<b>2 TEST SUMMARY</b> .....	<b>3</b>
<b>3 CONTENTS</b> .....	<b>4</b>
<b>4 GENERAL INFORMATION</b> .....	<b>5</b>
4.1 DETAILS OF E.U.T. ....	5
4.2 DESCRIPTION OF SUPPORT UNITS .....	5
4.3 MEASUREMENT UNCERTAINTY .....	6
4.4 TEST LOCATION.....	7
4.5 TEST FACILITY.....	7
4.6 DEVIATION FROM STANDARDS.....	7
4.7 ABNORMALITIES FROM STANDARD CONDITIONS .....	7
<b>5 EQUIPMENT LIST</b> .....	<b>8</b>
<b>6 RADIO SPECTRUM MATTER TEST RESULTS</b> .....	<b>9</b>
6.1 DFS: CHANNEL MOVE TIME .....	9
6.1.1 <i>E.U.T. Operation</i> .....	10
6.1.2 <i>Test Setup Diagram</i> .....	11
6.1.3 <i>Measurement Procedure and Data</i> .....	12
6.2 DFS: CHANNEL CLOSING TRANSMISSION TIME .....	13
6.2.1 <i>E.U.T. Operation</i> .....	14
6.2.2 <i>Test Setup Diagram</i> .....	15
6.2.3 <i>Measurement Procedure and Data</i> .....	16
<b>7 APPENDIX</b> .....	<b>17</b>
7.1 APPENDIX 15.407 .....	17



## 4 General Information

### 4.1 Details of E.U.T.

Power supply:	DC 4.2V
---------------	---------

### 4.2 Description of Support Units

The EUT has been tested as an independent unit.



### 4.3 Measurement Uncertainty

No.	Item	Measurement Uncertainty
1	Radio Frequency	$7.25 \times 10^{-8}$
2	RF conducted power	0.75dB
3	Adjacent channel selectivity	$\pm 3$ dB
4	Temperature test	1 °C
5	Humidity test	3%
6	Supply voltages	1.5%



#### **4.4 Test Location**

All tests were performed at:

SGS-CSTC Standards Technical Services Co., Ltd., Shenzhen Branch

No. 1 Workshop, M-10, Middle Section, Science & Technology Park, Shenzhen, Guangdong, China.  
518057.

Tel: +86 755 2601 2053 Fax: +86 755 2671 0594

No tests were sub-contracted.

#### **4.5 Test Facility**

The test facility is recognized, certified, or accredited by the following organizations:

- **CNAS (No. CNAS L2929)**

CNAS has accredited SGS-CSTC Standards Technical Services Co., Ltd. Shenzhen Branch EMC Lab to ISO/IEC 17025:2005 General Requirements for the Competence of Testing and Calibration Laboratories (CNAS-CL01 Accreditation Criteria for the Competence of Testing and Calibration Laboratories) for the competence in the field of testing.

- **A2LA (Certificate No. 3816.01)**

SGS-CSTC Standards Technical Services Co., Ltd., Shenzhen EMC Laboratory is accredited by the American Association for Laboratory Accreditation(A2LA). Certificate No. 3816.01.

- **VCCI**

The 3m Fully-anechoic chamber for above 1GHz, 10m Semi-anechoic chamber for below 1GHz, Shielded Room for Mains Port Conducted Interference Measurement and Telecommunication Port Conducted Interference Measurement of SGS-CSTC Standards Technical Services Co., Ltd. have been registered in accordance with the Regulations for Voluntary Control Measures with Registration No.: G-20026, R-14188, C-12383 and T-11153 respectively.

- **FCC –Designation Number: CN1178**

SGS-CSTC Standards Technical Services Co., Ltd., Shenzhen EMC Laboratory has been recognized as an accredited testing laboratory.

Designation Number: CN1178. Test Firm Registration Number: 406779.

- **Industry Canada (IC)**

Two 3m Semi-anechoic chambers and the 10m Semi-anechoic chamber of SGS-CSTC Standards Technical Services Co., Ltd. Shenzhen Branch EMC Lab have been registered by Certification and Engineering Bureau of Industry Canada for radio equipment testing with Registration No.: 4620C-1, 4620C-2, 4620C-3.

#### **4.6 Deviation from Standards**

None

#### **4.7 Abnormalities from Standard Conditions**

None



## 5 Equipment List

RF test system						
Item	Test Equipment	Manufacturer	Model No.	Inventory No.	Cal. Date (yyyy-mm-dd)	Cal. Due date (yyyy-mm-dd)
1	EXA Signal Analyzer (10Hz-44GHz)	KEYSIGHT	N9010A	SEM004-12	2017-07-17	2018-07-16
2	Signal Generator(9kHz-3GHz)	KEYSIGHT	N5171B	SEM006-13	2017-07-17	2018-07-16
3	MXG Vector Signal Generator	KEYSIGHT	N5182A	SEM006-14	2017-06-05	2018-06-04
4	DC Power Supply	KEYSIGHT	E3642A	SEM011-07	2017-06-05	2018-06-04
5	Manual Step Attenuator	KEYSIGHT	8494B	SEM021-05	2017-07-17	2018-07-16
6	Manual Step Attenuator	KEYSIGHT	8496B	SEM021-06	2017-07-17	2018-07-16
7	Power Sensor	KEYSIGHT	U2021XA	SEM009-13	2017-03-25	2018-03-24
8	Power Sensor	KEYSIGHT	U2021XA	SEM009-14	2017-03-23	2018-03-22
9	Power Sensor	KEYSIGHT	U2021XA	SEM009-15	2017-04-04	2018-04-03
10	Power Sensor	KEYSIGHT	U2021XA	SEM009-16	2017-03-20	2018-03-19
11	Bluetooth Tester	Rohde & Schwarz	CBT	W060-01	2017-06-21	2018-06-20
12	Universal Radio Communication Tester	Rohde & Schwarz	CMW 500	SEM010-03	2017-04-14	2018-04-13
13	Measurement Software	JS Tonscend	JS1120-2 BT/WIFI V2.6	N/A	N/A	N/A
14	Coaxial Cable	SGS	N/A	SEM028-01	2017-07-13	2018-07-12

General used equipment					
Equipment	Manufacturer	Model No	Inventory No	Cal Date	Cal Due Date
Humidity/ Temperature Indicator	Shanghai Meteorological Industry Factory	ZJ1-2B	SEM002-03	2017-09-29	2018-09-28
Humidity/ Temperature Indicator	Shanghai Meteorological Industry Factory	ZJ1-2B	SEM002-04	2017-09-29	2018-09-28
Humidity/ Temperature Indicator	Mingle	N/A	SEM002-08	2017-09-29	2018-09-28
Barometer	Changchun Meteorological Industry Factory	DYM3	SEM002-01	2017-04-18	2018-04-17





## 6 Radio Spectrum Matter Test Results

### 6.1 DFS: Channel Move Time

Test Requirement KDB 905462 D02 Section 5.1

Test Method: KDB 905462 D02 Section 7.8.3

Limit: 10 seconds(should be performed with Radar Type 0. The measurement timing begins at the end of the Radar Type 0 burst)



### 6.1.1 E.U.T. Operation

Operating Environment:

Temperature: 18.9 °C Humidity: 34 % RH Atmospheric Pressure: 1020 mbar

Pretest these mode to find the worst case:

- b:TX mode (Band 2A)
- c:TX mode (Band 2C).

The worst case for final test:

- b:TX mode (Band 2A)
- c:TX mode (Band 2C).

**6.1.2 Test Setup Diagram**

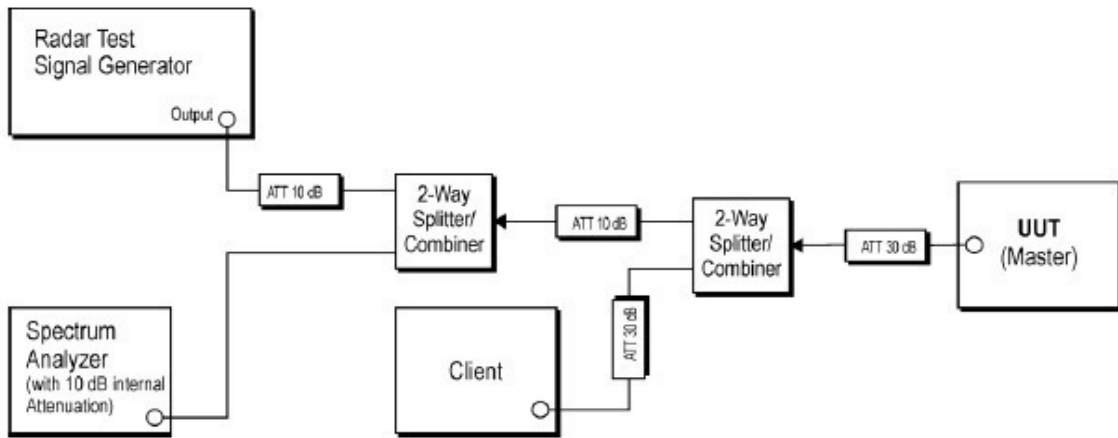

DFS master

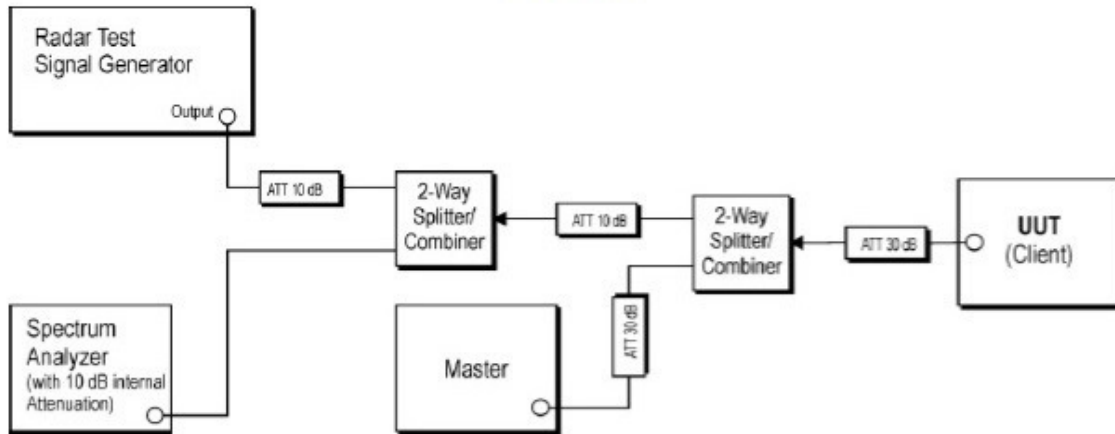

DFS slave with radar detection

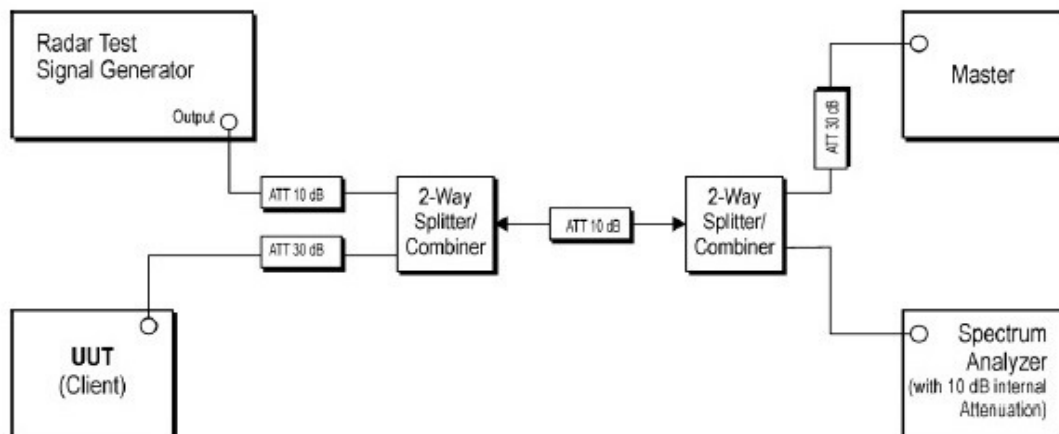

DFS slave without radar detection



### 6.1.3 Measurement Procedure and Data

- 1) The radar pulse generator is setup to provide a pulse at frequency that the master and client are operating. A type 0 radar pulse with a 1us pulse width and a 1428us PRI is used for the testing.
- 2) The vector signal generator is adjusted to provide the radar burst (18 pulses) at the level of approximately -61dBm at the antenna port of the master device.
- 3) A trigger is provided from the pulse generator to the DFS monitoring system in order to capture the traffic and the occurrence of the radar pulse.
- 4) EUT will associate with the master at channel. The file "iperf.exe" specified by the FCC is streamed from the PC 2 through the master and the client device to the PC 1 and played in full motion video using Media Player Classic Ver. 6.4.8.6 in order to properly load the network for the entire period of the test.
- 5) When radar burst with a level equal to the DFS Detection Threshold +1dB is generated on the operating channel of the U-NII device. At time T0 the radar waveform generator sends a burst of pulse of the radar waveform at Detection Threshold +1dB.
- 6) Observe the transmissions of the EUT at the end of the radar Burst on the Operating Channel. Measure and record the transmissions from the UUT during the observation time (Channel Move Time). One 15 seconds plot is reported for the Short Pulse Radar Type 0. The plot for the Short Pulse Radar Types start at the end of the radar burst. The Channel Move Time will be calculated based on the zoom in 600ms plot of the Short Pulse Radar Type.
- 7) Measurement of the aggregate duration of the Channel Closed Transmission Time method. With the spectrum analyzer set to zero span tuned to the center frequency of the EUT operating channel at the radar simulated frequency, peak detection, and max hold, the dwell time per bin is given by:  $Dwell (0.3ms) = S (12000ms) / B (4000)$ ; where Dwell is the dwell time per spectrum analyzer sampling bin, S is sweep time and B is the number of spectrum analyzer sampling bins. An upper bound of the aggregate duration of the intermittent control signals of Channel Closing Transmission Time is calculated by:  $C (ms) = N \times Dwell (0.3ms)$ ; where C is the Closing Time, N is the number of spectrum analyzer sampling bins (intermittent control signals) showing a U-NII transmission and Dwell is the dwell time per bin.
- 8) Measurement the EUT for more than 30 minutes following the channel move time to verify that no transmission or beacons occur on this channel.

The detailed test data see: Appendix 15.407



## **6.2 DFS: Channel Closing Transmission Time**

Test Requirement KDB 905462 D02 Section 5.1

Test Method: KDB 905462 D02 Section 7.8.3

Limit: 200 milliseconds + an aggregate of 60 milliseconds over remaining 10 second period(should be performed with Radar Type 0. The measurement timing begins at the end of the Radar Type 0 burst. It is comprised of 200 milliseconds starting at the beginning of the Channel Move Time plus any additional intermittent control signals required facilitating a Channel move (an aggregate of 60 milliseconds) during the remainder of the 10 second period. The aggregate duration of control signals will not count quiet periods in between transmissions)



### 6.2.1 E.U.T. Operation

Operating Environment:

Temperature: 18.9 °C      Humidity: 34 % RH      Atmospheric Pressure: 1020 mbar

Pretest these mode to find the worst case:

- b:TX mode (Band 2A)
- c:TX mode (Band 2C).

The worst case for final test:

- b:TX mode (Band 2A)
- c:TX mode (Band 2C).

### 6.2.2 Test Setup Diagram

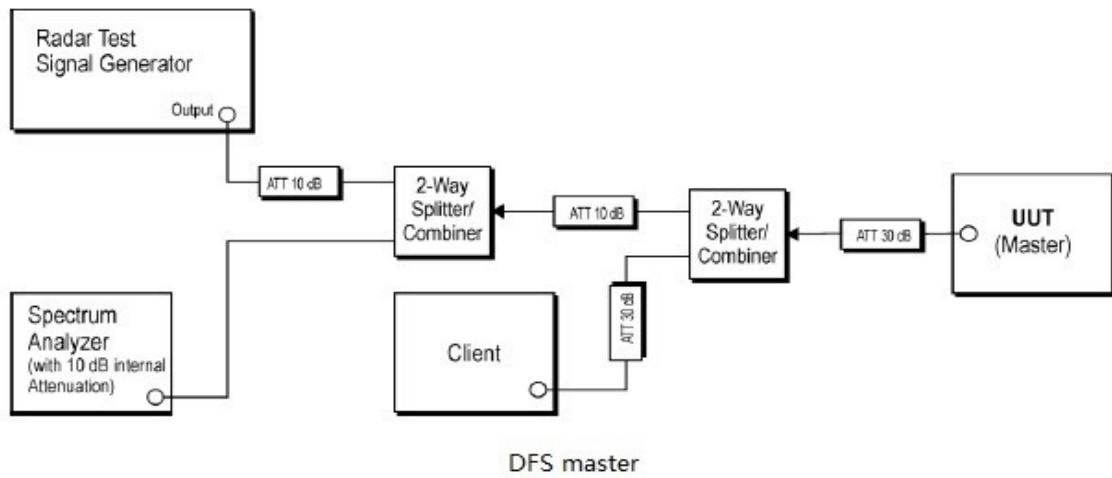

DFS master

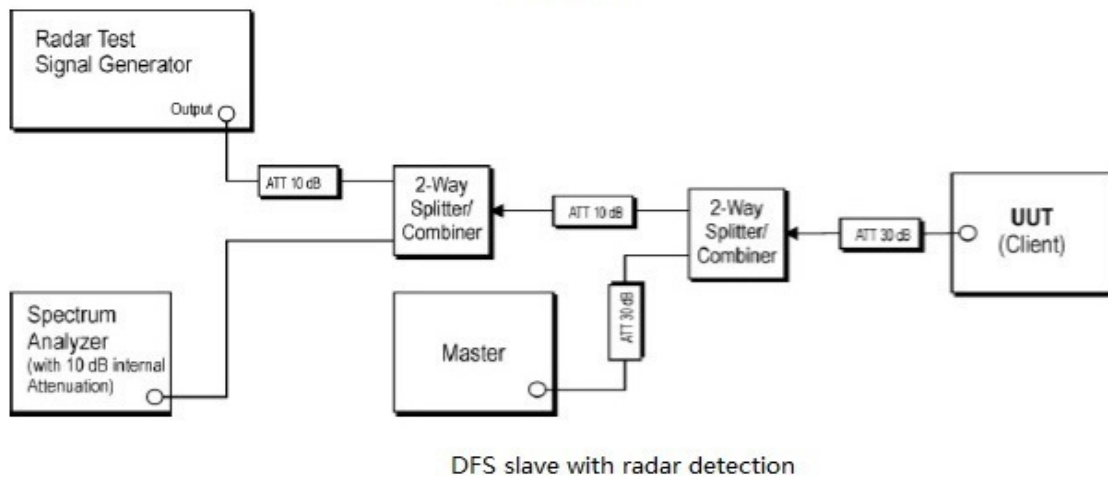

DFS slave with radar detection

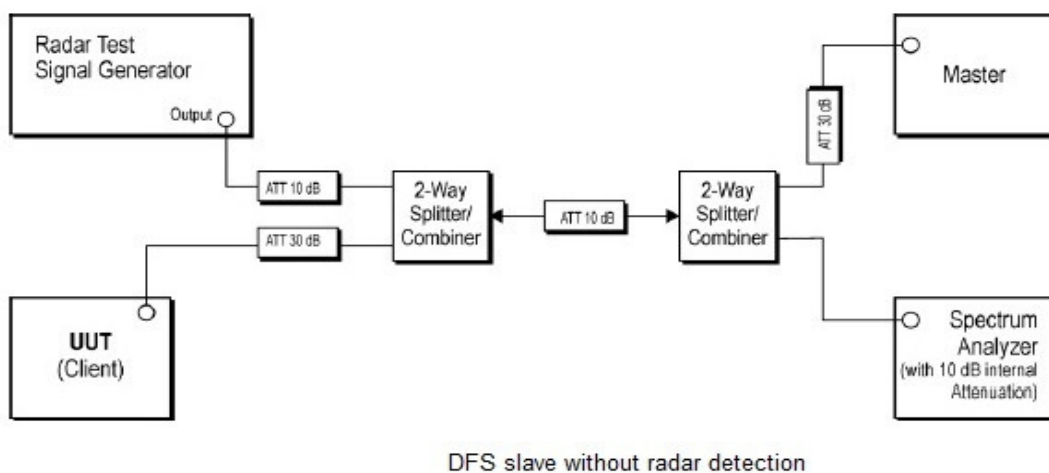

DFS slave without radar detection



### 6.2.3 Measurement Procedure and Data

- 1) The radar pulse generator is setup to provide a pulse at frequency that the master and client are operating. A type 0 radar pulse with a 1us pulse width and a 1428us PRI is used for the testing.
- 2) The vector signal generator is adjusted to provide the radar burst (18 pulses) at the level of approximately -61dBm at the antenna port of the master device.
- 3) A trigger is provided from the pulse generator to the DFS monitoring system in order to capture the traffic and the occurrence of the radar pulse.
- 4) EUT will associate with the master at channel. The file "iperf.exe" specified by the FCC is streamed from the PC 2 through the master and the client device to the PC 1 and played in full motion video using Media Player Classic Ver. 6.4.8.6 in order to properly load the network for the entire period of the test.
- 5) When radar burst with a level equal to the DFS Detection Threshold +1dB is generated on the operating channel of the U-NII device. At time T0 the radar waveform generator sends a burst of pulse of the radar waveform at Detection Threshold +1dB.
- 6) Observe the transmissions of the EUT at the end of the radar Burst on the Operating Channel. Measure and record the transmissions from the UUT during the observation time (Channel Move Time). One 15 seconds plot is reported for the Short Pulse Radar Type 0. The plot for the Short Pulse Radar Types start at the end of the radar burst. The Channel Move Time will be calculated based on the zoom in 600ms plot of the Short Pulse Radar Type.
- 7) Measurement of the aggregate duration of the Channel Closed Transmission Time method. With the spectrum analyzer set to zero span tuned to the center frequency of the EUT operating channel at the radar simulated frequency, peak detection, and max hold, the dwell time per bin is given by:  $Dwell (0.3ms) = S (12000ms) / B (4000)$ ; where Dwell is the dwell time per spectrum analyzer sampling bin, S is sweep time and B is the number of spectrum analyzer sampling bins. An upper bound of the aggregate duration of the intermittent control signals of Channel Closing Transmission Time is calculated by:  $C (ms) = N \times Dwell (0.3ms)$ ; where C is the Closing Time, N is the number of spectrum analyzer sampling bins (intermittent control signals) showing a U-NII transmission and Dwell is the dwell time per bin.
- 8) Measurement the EUT for more than 30 minutes following the channel move time to verify that no transmission or beacons occur on this channel.

The detailed test data see: Appendix 15.407



## 7 Appendix

### 7.1 Appendix 15.407

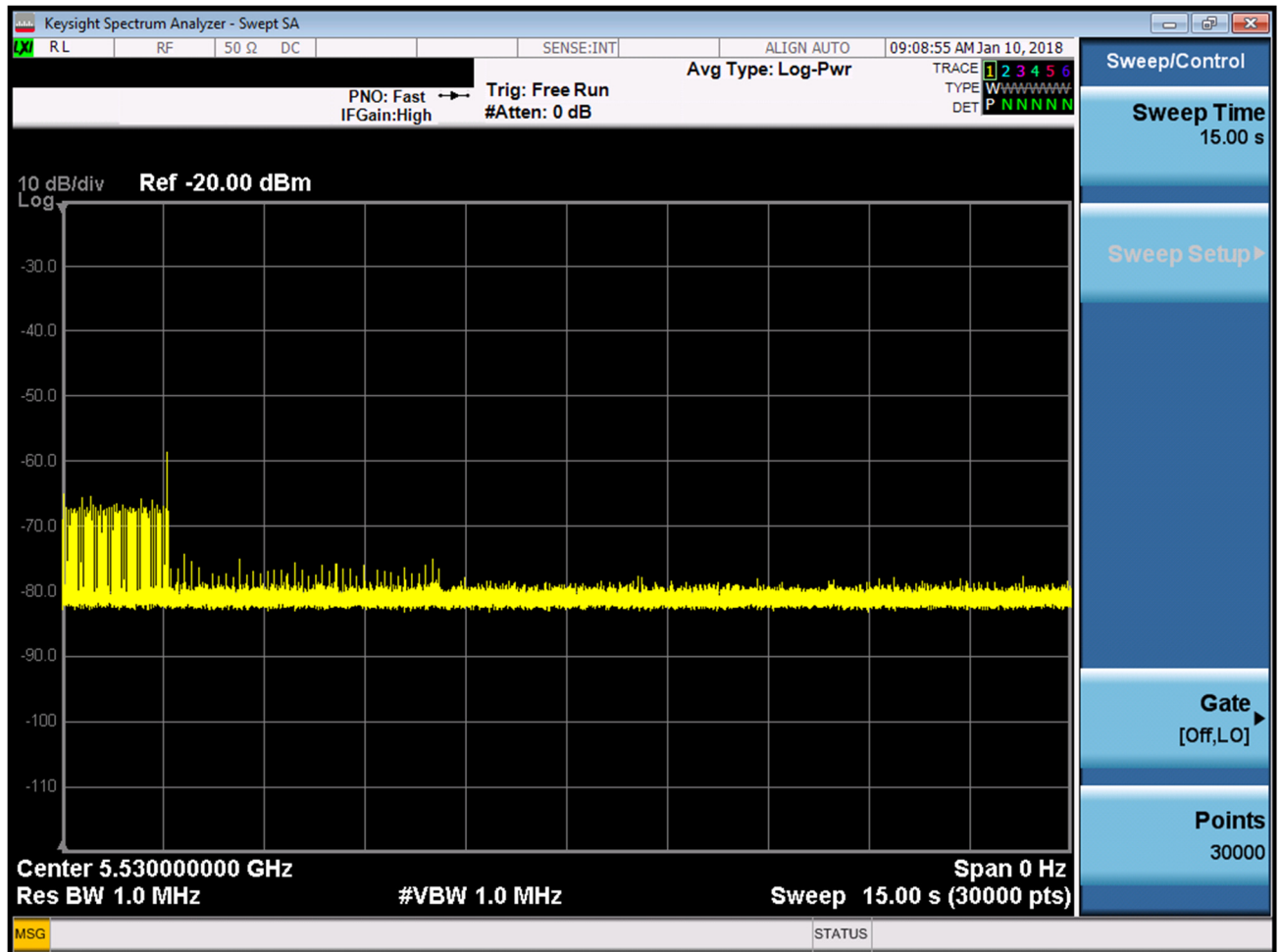

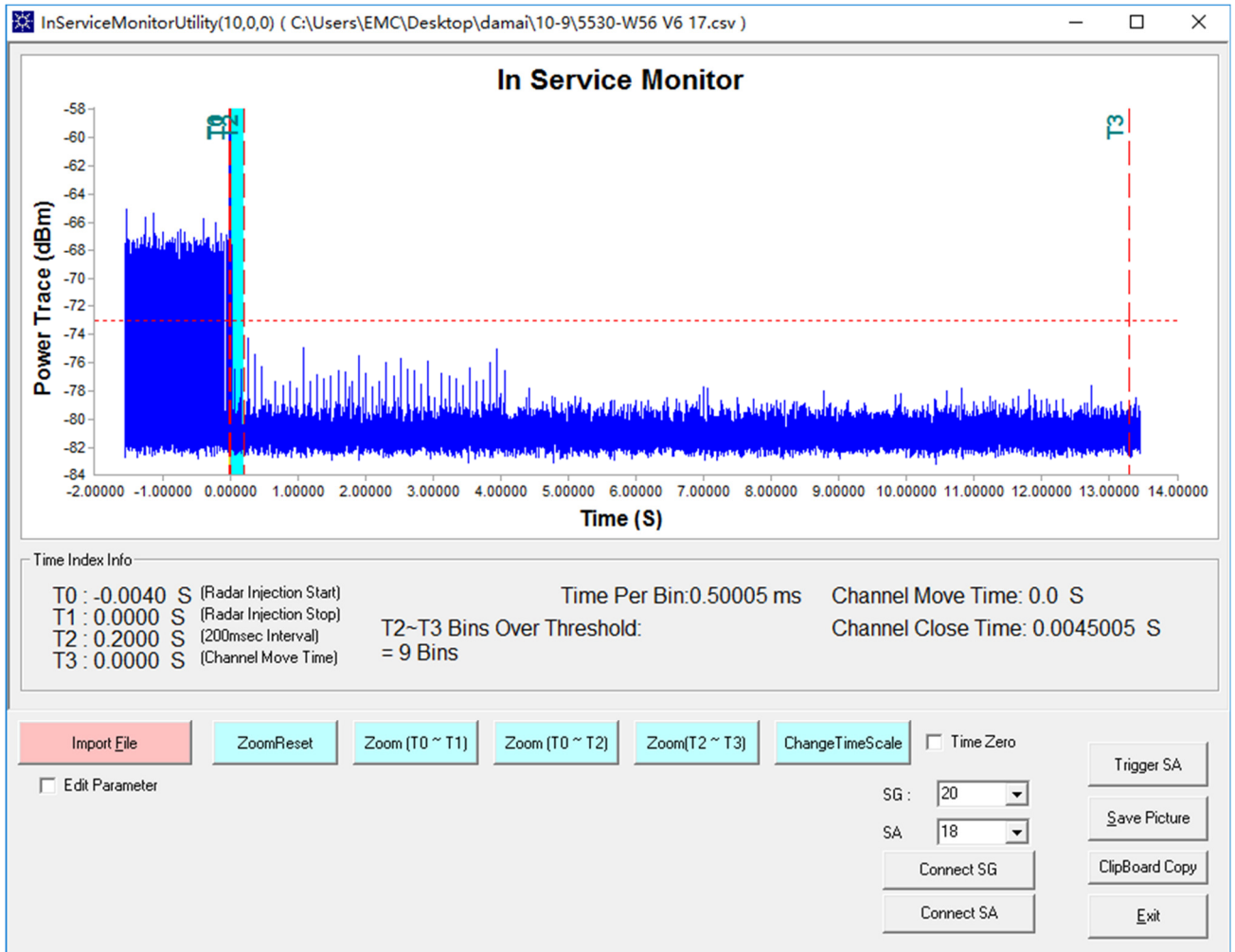

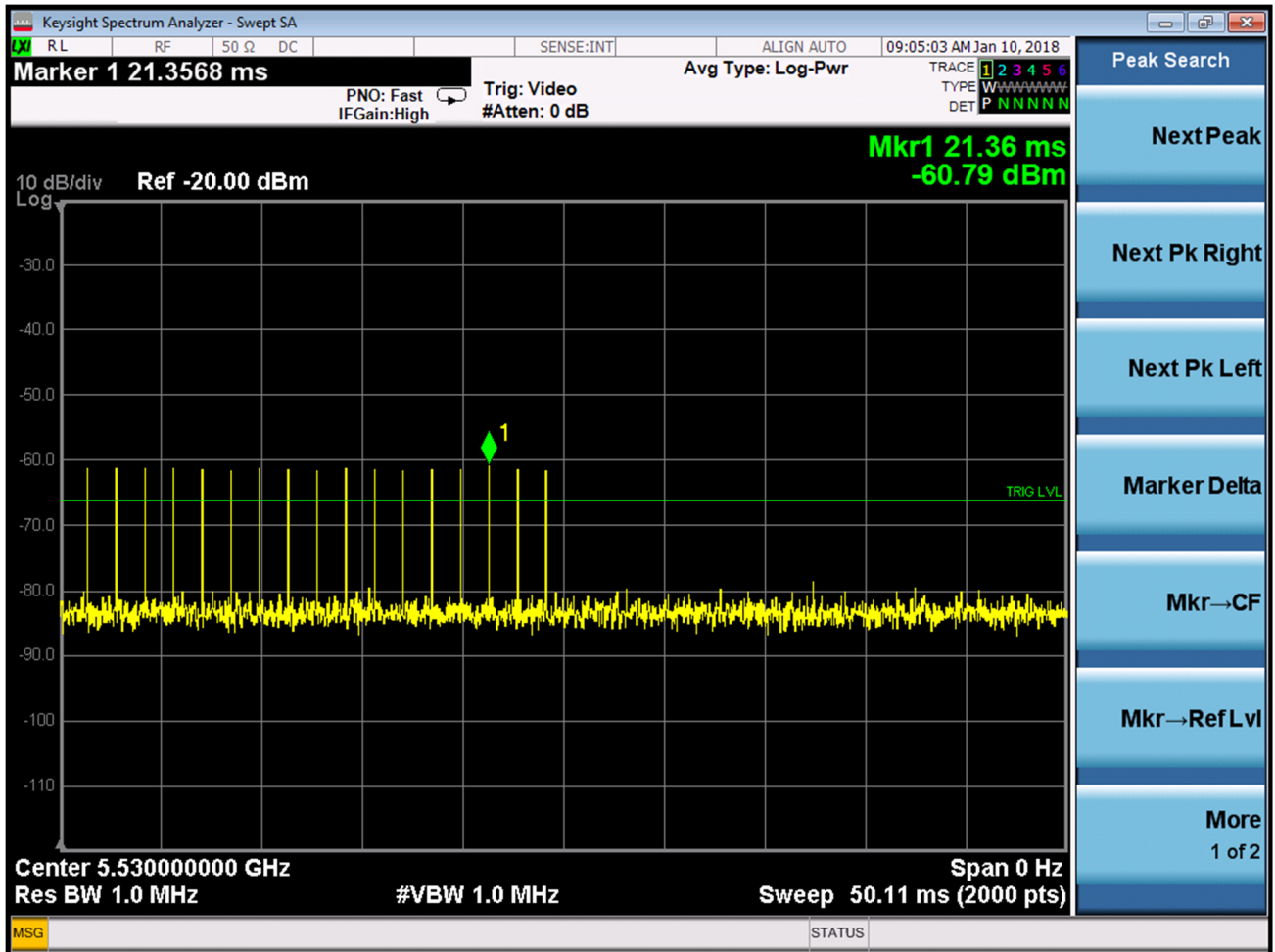

- End of the Report -