



中国认可
国际互认
检测
TESTING
CNAS L0310



EMC Test Report

Product Name: GPON Terminal

**Product Model: EchoLife HG8245H
EchoLife EG8245H**

Report Number: SYBH(E)03408760EB

FCC ID: QISEG8245HE

Reliability Laboratory of Huawei Technologies Co., Ltd.

(Global Compliance and Testing Center of Huawei Technologies Co., Ltd.)

Administration Building, Headquarters of Huawei Technologies Co., Ltd., Bantian, Longgang District,
Shenzhen, 518129, P.R.C

Tel: +86 755 28780808 Fax: +86 755 89652518



Notice

1. The laboratory has passed the accreditation by China National Accreditation Service for Conformity Assessment (CNAS). The accreditation number is L0310.
2. The laboratory has passed the accreditation by The American Association for Laboratory Accreditation (A2LA). The accreditation number is 2174.01.
3. The laboratory has been listed by the US Federal Communications Commission to perform electromagnetic emission measurements.
 - The recognition number for the test site located in Shenzhen is 97456
 - The recognition number for the test site located in Shanghai is 684868.
 - The recognition number for the test site located in Chengdu is 216797.
4. The laboratory has been listed by Industry Canada to perform electromagnetic emission measurements.
 - The recognition number for the test site located in Shenzhen is 6369A-1;
 - The recognition number for the test site located in Dongguan is 21741;
 - The recognition numbers for the test site located in Shanghai is 6369D, which contains 6369D-1 (3m chamber) and 6369D-2 (10m chamber).
 - The recognition number for the test site located in Chengdu is 6369E-1.
5. The laboratory has been listed by VCCI to perform electromagnetic emission measurements.
 - The recognition numbers for the test site located in Shenzhen are R-3892, G-415, C-4361, and T-1348.
 - The recognition numbers for the test site located in Dongguan are R-4344, G-946, C-4836 and T-2334.
6. The laboratory (Reliability Lab of Huawei Technologies Co., Ltd) is also named as “Global Compliance and Testing Center of Huawei Technologies Co., Ltd”; the both names have coexisted since 2009.
7. The test report is invalid if not marked with the signatures of the persons responsible for preparing and approving the test report.
8. The test report is invalid if there is any evidence of erasure and/or falsification.
9. The test report is only valid for the test samples.
10. Content of the test report, in part or in full, cannot be used for publicity and/or promotional purposes without prior written approval from the laboratory.



Applicant: Huawei Technologies Co., Ltd.
Address: Administration Building, Headquarters of Huawei Technologies Co., Ltd., Bantian, Longgang District, Shenzhen, 518129, P.R.C
Product Name: GPON Terminal
Product Model: EchoLife HG8245H
EchoLife EG8245H

Date of Receipt Sample: 2017-05-25
Start Date of Test: 2017-05-26
End Date of Test: 2017-06-06

Test Result: Pass

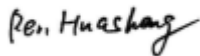
Approved by Senior Engineer:	2017-09-14	Ren Huasheng	
	Date	Name	Signature

Prepared by:	2017-09-13	Wang Ying	
	Date	Name	Signature



Modification Record

No.	Last Report No.	Modification Description
1	N/A	First report



Content

1	General Information	6
1.1	Applied Standard	6
1.2	Test Location	6
1.3	Test Environment Condition	6
2	Summary of Test Results	7
3	Equipment Specification	8
3.1	General Description	8
3.2	Specification.....	8
3.3	Board and Subassembly.....	10
4	System Configuration during EMC Test	11
4.1	Ports and Cables	11
4.2	Auxiliary Equipment	11
4.3	Test Configurations and Test Mode	11
4.4	Test Conditions and Connections.....	12
5	Details of Test Items	14
5.1	Radiated Emission 30 MHz to 18 GHz.....	14
5.2	Conducted Disturbance 0.15 MHz to 30 MHz.....	16
6	Main Test Instruments	17
7	System Measurement Uncertainty	18
8	Graph and Data of Emission Test	19
8.1	Radiated Disturbance	19
8.2	Conducted Disturbance	21
9	Photographs of Test Set-up.....	23
9.1	Radiated Emission.....	23
9.2	Conducted Emission.....	24
	Appendix: Abbreviation	25



1 General Information

1.1 Applied Standard

Applied Product Standard: FCC CFR47 Part 15 Subpart B:2015
ICES-003 Issue 6:2016

Test Method: ANSI C63.4:2014

1.2 Test Location

Test Location 1: Reliability Laboratory of Huawei Technologies Co., Ltd.
Address: Administration Building, Headquarters of Huawei Technologies
Co., Ltd., Bantian, Longgang District, Shenzhen, 518129, P.R.C

1.3 Test Environment Condition

Ambient Temperature: 20-25°C

Relative Humidity: 45-55%

Atmospheric Pressure: 101kPa



2 Summary of Test Results

Table 1 Test summary

EUT Classification: Class B Digital Device				
Test Items	Test Configuration	Limit	Test Result	Location
<u>Radiated Emissions</u> Enclosure Port	TC1-TC2	Class B	Pass	Location1
<u>Conducted Emissions</u> AC Power Port	TC1-TC2	Class B	Pass	Location1

Note:
1, Measurement taken is within the uncertainty of measurement system.
2, TC = Test configuration

3 Equipment Specification

3.1 General Description

The EchoLife HG8245H & EchoLife EG8245H GPON terminal (hereinafter referred to as HG8245H & EG8245H) are indoor optical network terminal (ONT) designed for home users and small office. The HG8245H & EG8245H uses the gigabit-capable passive optical network (GPON) technology to provide a high-speed data channel through a single optical fiber. In this way, you can use the HG8245H & EG8245H to enjoy the high-speed data service, quality voice service, superior video service, and secure and reliable wireless access service.

As a network terminal, the HG8245H & EG8245H are deployed at the GPON access layer and connects the home users and SOHO users to the Internet through the optical upstream port. On the local area network (LAN) side, the HG8245H & EG8245H provide abundant hardware ports to meet multiple networking requirements of home users.

- ◆ Four 10/100/1000 Base-T Ethernet ports that can function as the service ports for service terminals such as PC, set top box (STB), and video phone.
- ◆ Two TEL ports that provide superior and cost-effective voice over IP (VoIP), fax over IP (FoIP), and modem over IP (MoIP) services.
- ◆ One WLAN port to support a secure and reliable high-speed wireless network.
- ◆ One USB port that can be attached with USB disks to provide convenient home network attached storage and file sharing services.

Products may have different colors, antennas and silkscreens. The following shows an example. EchoLife EG8245H is the same as EchoLife HG8245H except the name, so only EchoLife HG8245H was adopted in the test.

3.2 Specification

Table 2 Main equipment specification

Rated Input Voltage	Adapter in: ~ 100 V to 240 V, 50/60 Hz Board in: DC 12V
Rated Power (W)	Max 24 W
Dimensions (W x D x H)	176 mm (W) x 138.5 mm (D) x 28 mm (H)
Weight (kg)	About 0.6 kg
Frequency of the Internal Source (MHz)	25 MHz, 40 MHz, 125 MHz, 480 MHz, 1244 MHz, 2488 MHz



Figure 1. EUT appearance



Figure 2.EUT Appearance (Adapter: HW-120200U7W)



3.3 Board and Subassembly

Table 3 Board list

Board	
Board Name	Description
HG8245XGA	1PON, 4GE, 2POTS, 1USB, 1WIFI

Table 4 Subassembly list

Subassembly			
Subassembly Name	Model	Manufacturer	Description
Adapter	HW-120200U7W	Shenzhen Huntkey Electric Co., Ltd	Input voltage: ~ 100V-240V, 50/60Hz 0.8A Output voltage: == 12 V, 2 A
	HW-120200U7W	Dongguan Shilong Fuhua electronic Co.,Ltd	Input voltage: ~ 100V-240V, 50/60Hz 0.8A Output voltage: == 12 V, 2 A



4 System Configuration during EMC Test

The Equipment under Test (EUT) was functioning correctly during all tests. The EUT was installed within the test site and was configured to simulate a typical configuration.

4.1 Ports and Cables

Table 5 Ports and cables

Port	Quantity	Length (m)	Connector	Type of Cable
AC Power Port	1	1.5	N/A	Unshielded
POTS	2	5	RJ11	UTP-CAT3
LAN	4	10	RJ45	UTP-CAT5E
PON	1	10	SC	Single-mode optical fiber

4.2 Auxiliary Equipment

Table 6 Auxiliary equipment

Equipment	Model	Manufacturer	S/N	Calibration Date	Calibration Interval (month)
TELEPHONE	TCL 37	TCL	N/A	N/A	N/A
Data network analyzer	Smartbits600	Spirent	SZ0500038070	2017-04-28	12
PC	Lenovo M4000	LEGEND	N/A	N/A	N/A
OLT	MA5603T	Huawei	N/A	N/A	N/A
USB memorizer	N/A	Kingston	N/A	N/A	N/A
Notebook PC	HP 2540p	HP	3105033009	N/A	N/A

4.3 Test Configurations and Test Mode

4.3.1 Test Configuration

The equipment under test (EUT) was connected to ancillary devices in order to simulate normal operating conditions (with reference to the guidance given in the standard for this type of equipment). There were two test configurations. TC1 - TC2 were shown in the following table and figures:

Table 7 Test configuration

Configuration No.	Configuration Description
TC1	Adapter (HuntKey)*: HW-120200U7W
TC2	Adapter (UE)*: HW-120200U7W

Note*: "Huntkey" is the trademark of Shenzhen Huntkey Electric Co., Ltd manufacturer, "UE" is the trademark of Dongguan Shilong Fuhua Electronic Co., Ltd manufacturer.

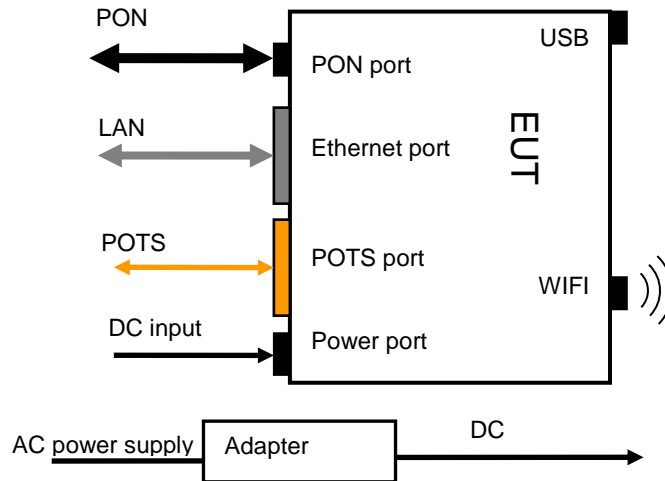

Figure 3.: Test configuration (TC1 ~ TC2)

4.3.2 Test Mode

There were two test Modes. TM1 and TM2 were shown in the table below:

Table 8 Test modes

Test Mode	Mode Describe
TM1	WLAN idle Mode
TM2	WLAN traffic Mode

When the EUT was required to be in the traffic mode for WLAN mode, a call was set up using a series of command and the following conditions should be met:

The EUT should be commended to operate at maximum transmit power 19 dBm;

When the EUT was in the idle mode, the EUT switched on but didn't transmit power, available for service and available to respond to a request to set up a call.

4.4 Test Conditions and Connections

The HG8245H was connected with the OLT through a single-mode optical fiber and 15–20 dB optical attenuation is added. The Ethernet ports of HG8245H should connect to the SmartBits 600. The data flow rates of each Ethernet port is nearly 250M when the Ethernet port is GE. Data transmission is normal at the Ethernet port with no packet loss or error codes. Each POTS port of HG8245H should connect with a phone. Voice service was configured on the board so that voice connection can be built between phone1 and phone2.

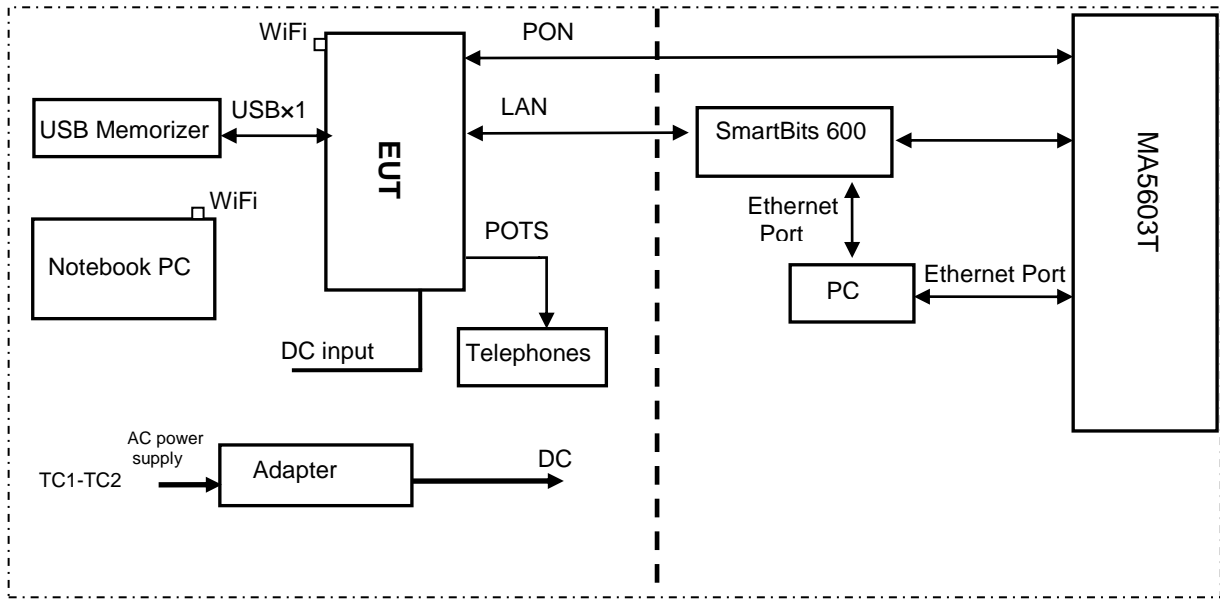

Figure 4. Test connection of TC1 ~ TC2

5 Details of Test Items

5.1 Radiated Emission 30 MHz to 18 GHz

5.1.1 Test Procedure

The test site semi-anechoic chamber for 30MHz to 1GHz test has met the requirement of NSA tolerance 4 dB according to the standard ANSI C63.4. The test distance was 3m. The set-up and test methods were according to ANSI C63.4.

The test site full-anechoic chamber for above 1GHz test has met the requirement of S_{VSWR} tolerance 6 dB in accordance with the standard ANSI C63.4. The test distance was 3 m for above 1GHz.

A preliminary scan and a final scan of the emissions were made from 30 MHz to 18 GHz by using test script of software; the emissions were measured using Quasi-Peak Detector for 30 MHz to 1 GHz, Average and Peak detector for above 1 GHz. The maximal emission value was acquired by adjusting the antenna height, polarisation and turntable azimuth in accordance with the software setup. Normally, the height range of antenna was 1 m to 4 m, the azimuth range of turntable was 0° to 360°, The receive antenna has two polarizations V and H.

The test set-up is shown in diagram as below:

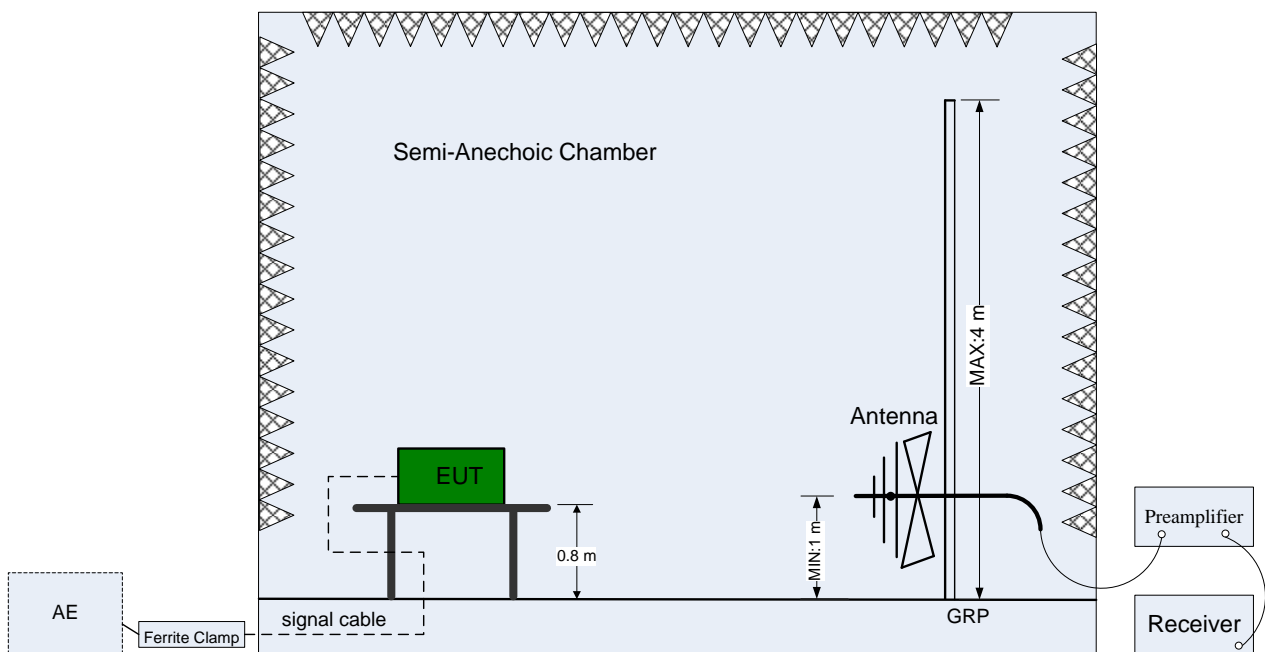

Figure 5. Test set-up of radiated disturbance (30 MHz-1 GHz)

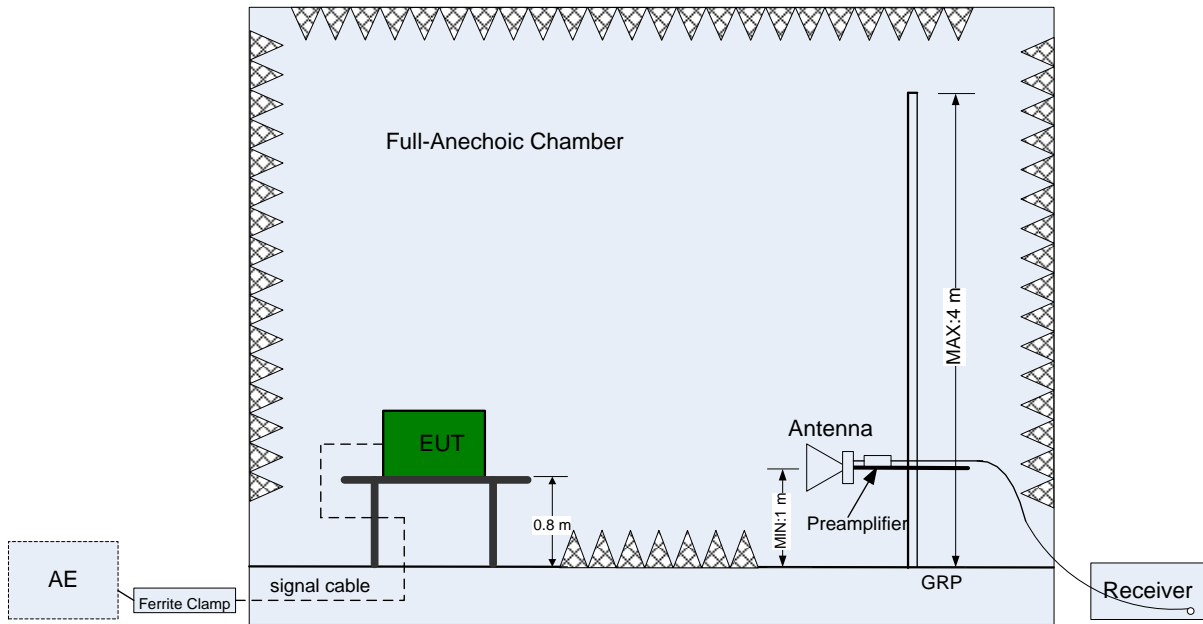

Figure 6. Test set-up of radiated disturbance (above 1 GHz)

5.1.2 Test Results

The EUT has met the requirements for radiated emission of enclosure port.
For the test data, see section 8.1.

Table 9 Test limits for 30MHz to 1GHz at a measuring distance of 3m

Frequency range	30 MHz to 1 GHz	
Measuring distance	3 m	
Classification	Class B	
Limits(Class B)	30 MHz to 88 MHz	40.0 dB μ V/m
	88 MHz to 216 MHz	43.5 dB μ V/m
	216 MHz to 960 MHz	46.0 dB μ V/m
	960 MHz to 1 GHz	53.9 dB μ V/m

Table 10 Test limits for above 1GHz at a measuring distance of 3m

Frequency range	1 GHz to 18 GHz	
Measuring distance	3 m	
Classification	Class B	
Limits(Class B)	AV Detector	PK Detector
	53.9 dB μ V/m	73.9 dB μ V/m

Note: The highest frequency of the internal sources of the EUT is 2488 MHz, the measurement was made up to 18 GHz.

5.2 Conducted Disturbance 0.15 MHz to 30 MHz

5.2.1 Test Procedure

The EUT was configured as described in section 4. The mains cable of the EUT must be connected to LISN. The LISN shall be placed 0.8 m from the boundary of EUT and bonded to a ground reference plane for LISN mounted on top of the ground reference plane. This distance is between the closest points of the LISN and the EUT. All other units of the EUT and associated equipment shall be at least 0.8m from the LISN.

The test set-up is shown in diagram as below:

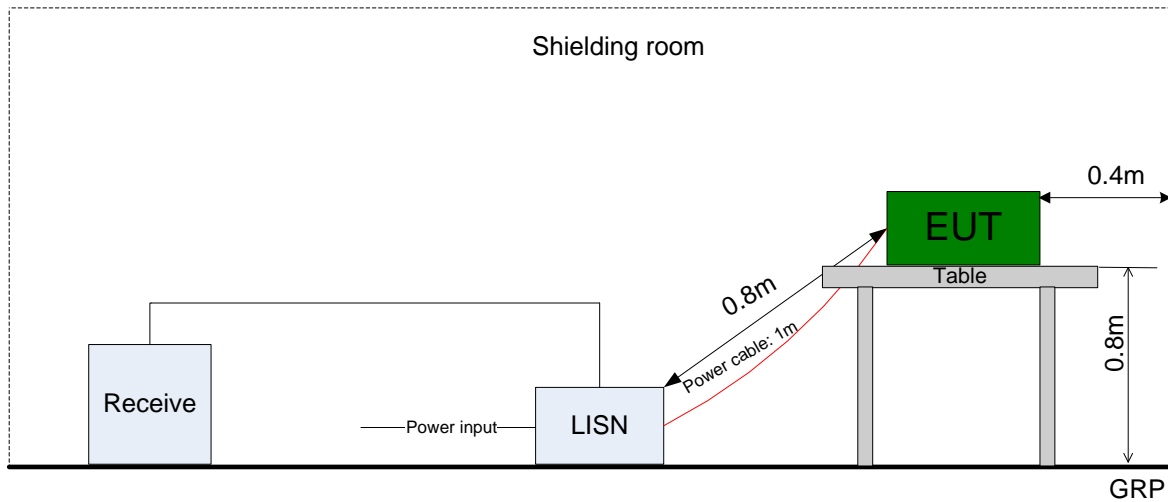

Figure 7. Test set-up of conducted disturbance for AC power port

5.2.2 Test Results

The EUT has met the requirements of FCC Part15 and ICES 003 for Conducted Disturbance of AC Power Port

For the test data, see section 8.2

Table 11 Limits of AC power port

Frequency range	150 kHz to 30 MHz	
Classification	Class B	
Limit(Class B)	Voltage limits (dB μ V)	
	QP	AV
0.15 to 0.5 MHz	66 to 56	56 to 46
0.5 to 5 MHz	56	46
5 to 30 MHz	60	50

**6 Main Test Instruments**

Table 12 Main test instrument

Test Item	Test Instrument	Model	Manufacturer	Calibration Date	Calibration Interval (Month)
Radiated emission (G2 3m chamber)	EMI test receiver	ESU40 (100144)	R&S	2017-03-06	12
	Bilog antenna	CBL 6112B (2536)	Schaffner	2015-08-15	24
	Horn antenna	HF906 (359287/006)	R&S	2016-08-20	24
	Chamber_NSA	3m chamber	Albatross	2017-03-26	24
	Chamber_SVSWR	3m chamber	Albatross	2015-08-25	24
Conducted emission (G2)	EMI test receiver	ESCI (100929)	R&S	2017-05-05	12
	Artificial mains network	ENV4200 (100046)	R&S	2017-02-14	12
Software Information					
Test Item		Software Name	Manufacturer	Version	
Radiated emission (G2 3m chamber)		ES-K1	R&S	V1.7.1	
Conducted emission (G2)		ES-K1	R&S	V1.7.1	

Table 13 Test cable and amplifiers for RE test

Name	Model	Manufacturer	S/N	Validation Date	Validation Interval (month)	Remark
Coaxial cable	SF1041A	HUBER+SUHNER	/	2017-03-12	3	30MHz to 1GHz
Coaxial cable	S04272B	HUBER+SUHNER	/	2017-03-12	3	30MHz to 1GHz
Coaxial cable	SUCOFLE X 106	HUBER+SUHNER	41937/6	2017-03-12	3	30MHz to 1GHz
Coaxial cable	S04272B	HUBER+SUHNER	/	2017-03-12	3	30MHz to 1GHz
Coaxial cable	SLSLL40-KMKM-01.00M	Times	10095A	2017-03-12	3	30MHz to 1GHz
Coaxial cable	MFR54102	GORE	550458	2017-03-12	3	1GHz to 18GHz
Coaxial cable	SUCOFLE X 106	SUHNER	41950/6	2017-03-12	3	1GHz to 18GHz
Coaxial cable	SUCOFLE X 106	SUHNER	41959/6	2017-03-12	3	1GHz to 18GHz
Coaxial cable	SUCOFLE X 100	SUHNER	/	2017-03-12	3	1GHz to 18GHz
amplifiers	8447D	Agilent	2944A10174	2017-02-14	12	30MHz to 1GHz



amplifiers	NTWLNA-10180	rflight	A150611 165	/	/	1GHz to 18GHz
------------	--------------	---------	----------------	---	---	------------------

7 System Measurement Uncertainty

For a 95% confidence level, the measurement expanded uncertainties for defined systems, in accordance with the recommendations of ISO 17025 were:

Table 14 System measurement uncertainty

Items		Extended Uncertainty
Radiated emission (G2 3m chamber)	Field strength (dBµV/m)	U=5.5 dB; k=2 (30 MHz-1 GHz)
		U=5.2 dB; k=2 (1 GHz-18 GHz)
Conducted Emission (G2)	Disturbance Voltage (dBµV)	U=2.55 dB; k=2



8 Graph and Data of Emission Test

8.1 Radiated Disturbance

8.1.1 Radiated Disturbance of TC1 ~ TC2 for 30MHz-1GHz

Graph of Test result (30 MHz-1 GHz)

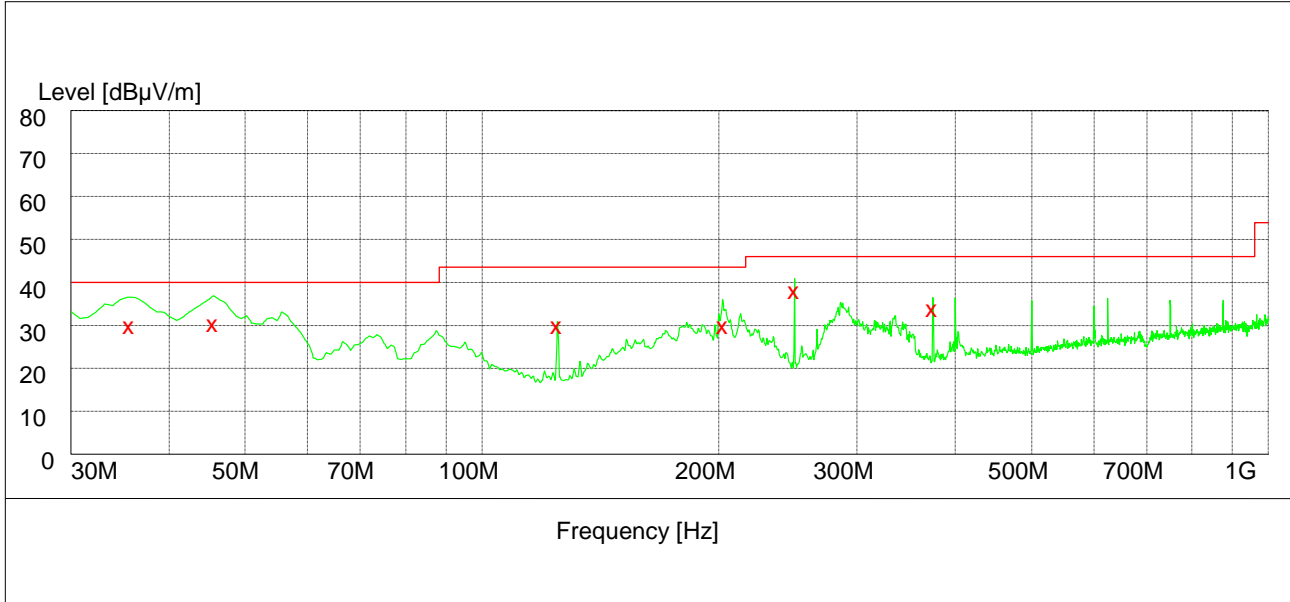

Measurement Result: QP Detector

Frequency MHz	Level dBµV/m	Transd dB	Limit dBµV/m	Margin dB	Height cm	Azimuth deg	Polarisation
35.760000	31.50	-8.1	40.0	8.5	109.0	275.00	VERTICAL
45.660000	31.90	-13.6	40.0	8.1	100.0	237.00	VERTICAL
124.980000	31.40	-14.0	43.5	12.1	148.0	31.00	HORIZONTAL
203.160000	31.40	-12.4	43.5	12.1	144.0	36.00	HORIZONTAL
250.020000	39.60	-9.8	46.0	6.4	100.0	112.00	HORIZONTAL
375.000000	35.50	-6.2	46.0	10.5	100.0	125.00	HORIZONTAL

Note:

1. Margin=Limit-Level

Level =Reading level by receiver + Transd (Antenna factor + cable loss – preamplifier gain)

The reading level is used to calculate by software which is not shown in the sheet.

2. The test configurations TC1-TC2 was tested, but the worse test result was supplied.



8.1.2 Radiated Disturbance of TC1 ~ TC2 for 1GHz-18GHz

Graph of Test result (above 1 GHz)

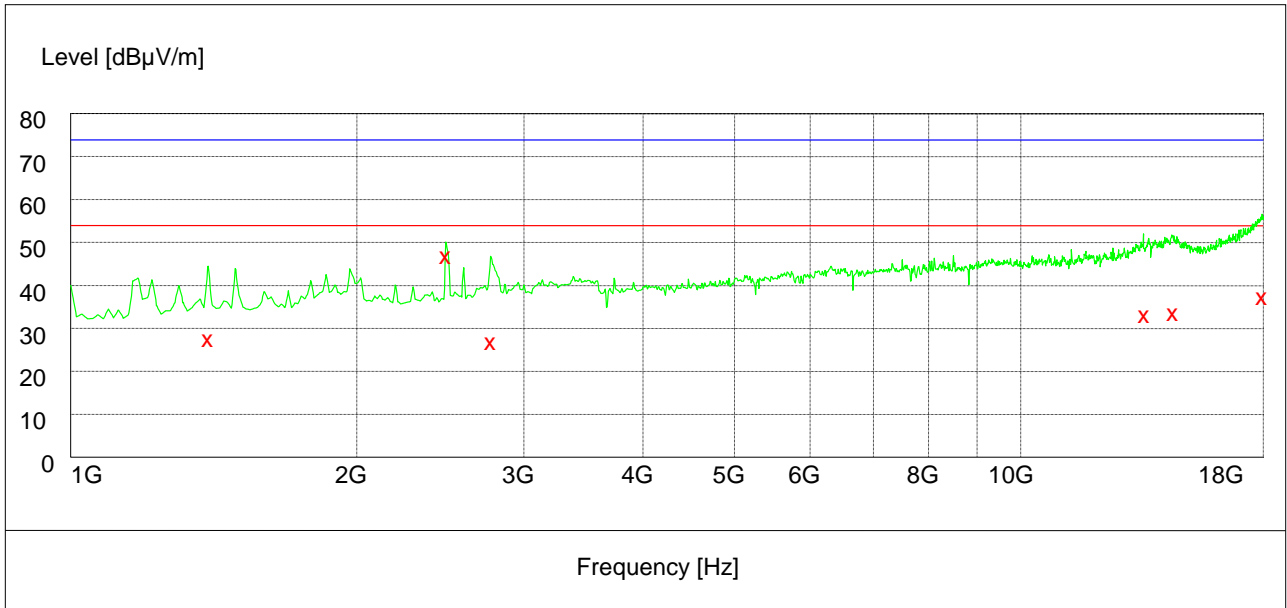

Measurement Result: AV Detector

Frequency MHz	Level dBµV/m	Transd dB	Limit dBµV/m	Margin dB	Height cm	Azimuth deg	Polarisation
1400.000000	29.20	-5.0	53.9	24.7	100.0	18.00	HORIZONTAL
2488.500000	48.50	0.7	53.9	5.4	100.0	258.00	VERTICAL
2775.000000	28.60	1.8	53.9	25.3	100.0	197.00	HORIZONTAL
13525.500000	34.70	21.3	53.9	19.2	150.0	217.00	HORIZONTAL
14505.500000	35.20	23.1	53.9	18.7	100.0	224.00	HORIZONTAL
17999.500000	38.90	30.9	53.9	15.0	145.0	214.00	VERTICAL

Note:

1. Margin=Limit-Level

Level =Reading level by receiver + Transd (Antenna factor + cable loss – preamplifier gain)

The reading level is used to calculate by software which is not shown in the sheet.

2. The test configurations TC1 ~ TC2 were tested, and the worse test result was supplied.



8.2 Conducted Disturbance

8.2.1 AC Power Port Test Data of TC1

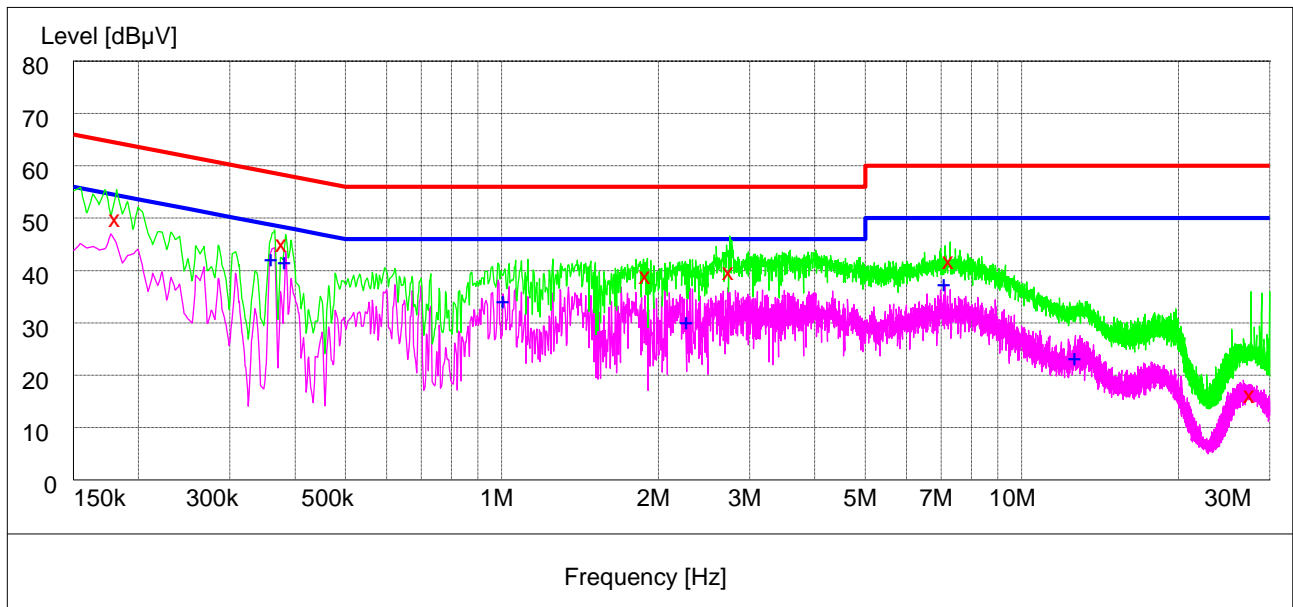

Measurement Result: QP Detector

Frequency (MHz)	Level (dBµV)	Transd (dB)	Limit (dBµV)	Margin (dB)	Line	PE
0.181500	50.90	10.5	64	13.5	N	FLO
0.379500	46.10	10.5	58	12.2	L3	FLO
1.900500	40.00	10.7	56	16.0	N	FLO
2.746500	40.70	10.5	56	15.3	N	FLO
7.291500	42.80	10.6	60	17.2	N	FLO
27.627000	17.30	10.7	60	42.7	L3	FLO

Measurement Result: AV Detector

Frequency (MHz)	Level (dBµV)	Transd (dB)	Limit (dBµV)	Margin (dB)	Line	PE
0.361500	43.10	10.5	49	5.6	L3	FLO
0.384000	42.60	10.5	48	5.6	L3	FLO
1.009500	35.20	10.5	46	10.8	N	FLO
2.274000	31.30	10.6	46	14.7	L3	FLO
7.134000	38.50	10.6	50	11.5	N	FLO
12.709500	24.30	10.6	50	25.7	N	FLO

Note:

Margin=Limit-Level

Level= Reading level+ Transd (cable loss + correction factor)

The reading level is used to calculate by software which is not shown in the sheet.



8.2.2 AC Power Port Test Data of TC2

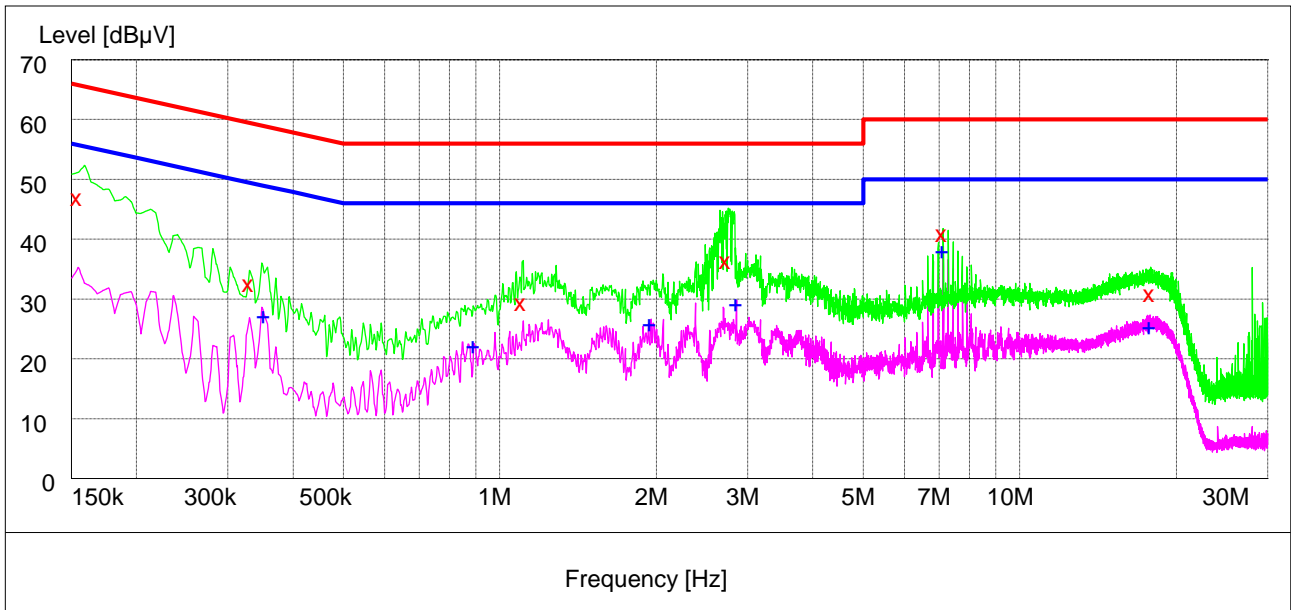

Measurement Result: QP Detector

Frequency (MHz)	Level (dBµV)	Transd (dB)	Limit (dBµV)	Margin (dB)	Line	PE
0.154500	47.80	10.6	66	18.0	N	FLO
0.330000	33.40	10.5	60	26.1	N	FLO
1.104000	30.30	10.7	56	25.7	L3	FLO
2.728500	37.30	10.5	56	18.7	L3	FLO
7.134000	41.70	10.6	60	18.3	L3	FLO
17.848500	31.70	10.5	60	28.3	L3	FLO

Measurement Result: AV Detector

Frequency (MHz)	Level (dBµV)	Transd (dB)	Limit (dBµV)	Margin (dB)	Line	PE
0.352500	28.10	10.5	49	20.8	N	FLO
0.892500	23.00	10.5	46	23.0	L3	FLO
1.950000	26.70	10.6	46	19.3	L3	FLO
2.854500	30.10	10.5	46	15.9	L3	FLO
7.134000	38.80	10.6	50	11.2	L3	FLO
17.830500	26.20	10.5	50	23.8	L3	FLO

Note:

Margin=Limit-Level

Level= Reading level+ Transd (cable loss + correction factor)

The reading level is used to calculate by software which is not shown in the sheet.

9 Photographs of Test Set-up

9.1 Radiated Emission

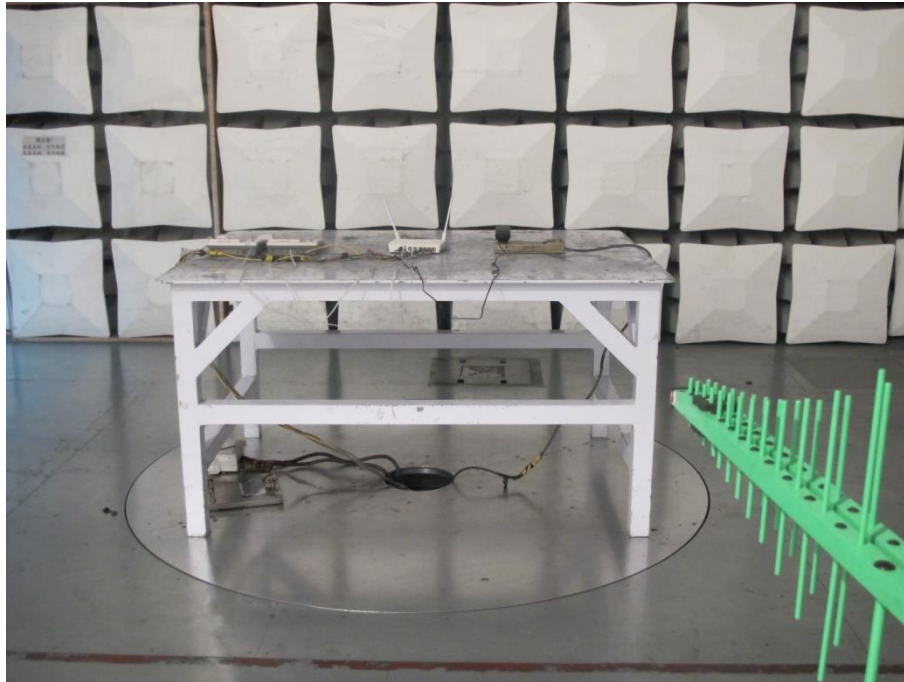

Radiated emission for 30 MHz-1 GHz



Radiated emission for 1GHz to 18GHz

9.2 Conducted Emission



Conducted emissions of AC power port

**Appendix: Abbreviation**

Table 15 Abbreviation

Abbreviation	Full Name
EMC	Electromagnetic Compatibility
EMI	Electromagnetic Interference
EUT	Equipment Under Test
AE	Auxiliary Equipment
AC	Alternate Current
DC	Direct Current
NSA	Normalized Site Attenuation
S_{VSWR}	Site Voltage Standing Wave Ratio
LISN	Line Impedance Stabilization Network
TC	Test configuration
N/A	Not Applicable

END