



中国认可  
国际互认  
检测  
TESTING  
CNAS L2264

## RF TEST REPORT

**Applicant** Huawei Technologies Co., Ltd.  
**FCC ID** QISEAN3810A  
**Product** eLTE-U Airnode  
**Model** eAN3810A  
**Report No.** RHA1702-0018RF01R8  
**Issue Date** July 24, 2017

TA Technology (Shanghai) Co., Ltd. tested the above equipment in accordance with the requirements in **FCC CFR47 Part 15E (2017)**. The test results show that the equipment tested is capable of demonstrating compliance with the requirements as documented in this report.

Performed by: Xianqing Li

Approved by: Kai Xu

### TA Technology (Shanghai) Co., Ltd.

No.145, Jintang Rd, Tangzhen Industry Park, Pudong Shanghai, China

TEL: +86-021-50791141/2/3

FAX: +86-021-50791141/2/3-8000



## TABLE OF CONTENT

1. Test Laboratory .....	4
1.1. Notes of the test report.....	4
1.2. Test facility .....	4
1.3. Testing Location.....	5
2. General Description of Equipment under Test.....	6
3. Test Information .....	7
4. Test Configuration .....	8
5. Test Case Results .....	9
5.1. Occupied Bandwidth .....	9
5.2. Power Output –Conducted .....	24
5.3. Frequency Stability.....	34
5.4. Power Spectral Density .....	42
5.5. Unwanted Emission .....	52
5.6. Conducted spurious emissions at antenna port .....	93
5.7. Conducted Emission .....	102
6. Main Test Instruments.....	104
ANNEX A: EUT Appearance and Test Setup .....	105
A.1 EUT Appearance .....	105
A.2 Test Setup .....	107



## Summary of measurement results

Number	Summary of measurements of results	Clause in FCC rules	Verdict
1	Maximum peak conducted output power	15.407(a)	PASS
2	Occupied bandwidth	15.407(a)	PASS
3	Frequency stability	15.407(g)	PASS
4	Maximum power spectral density	15.407(a)	PASS
5	Unwanted Emissions	15.407(b)	PASS
6	Conducted spurious emissions at antenna port	15.407(b)	PASS
7	Conducted Emissions	15.207	PASS

Date of Testing: February 15, 2017~ March 2, 2017 and June 30, 2017

## 1. Test Laboratory

### 1.1. Notes of the test report

This report shall not be reproduced in full or partial, without the written approval of **TA technology (shanghai) co., Ltd.** The results documented in this report apply only to the tested sample, under the conditions and modes of operation as described herein. Measurement Uncertainties were not taken into account and are published for informational purposes only. This report is written to support regulatory compliance of the applicable standards stated above. This report must not be used by the client to claim product certification, approval, or endorsement by CNAS or any government agencies.

### 1.2. Test facility

#### **CNAS (accreditation number: L2264)**

TA Technology (Shanghai) Co., Ltd. has obtained the accreditation of China National Accreditation Service for Conformity Assessment (CNAS).

#### **FCC (recognition number is 428261)**

TA Technology (Shanghai) Co., Ltd. has been listed on the US Federal Communications Commission list of test facilities recognized to perform electromagnetic emissions measurements.

#### **IC (recognition number is 8510A)**

TA Technology (Shanghai) Co., Ltd. has been listed by industry Canada to perform electromagnetic emission measurement.

#### **VCCI (recognition number is C-4595, T-2154, R-4113, G-766)**

TA Technology (Shanghai) Co., Ltd. has been listed by industry Japan to perform electromagnetic emission measurement.

#### **A2LA (Certificate Number: 3857.01)**

TA Technology (Shanghai) Co., Ltd. has been listed by American Association for Laboratory Accreditation to perform electromagnetic emission measurement.



### 1.3. Testing Location

Company: TA Technology (Shanghai) Co., Ltd.  
Address: No.145, Jintang Rd, Tangzhen Industry Park, Pudong  
City: Shanghai  
Post code: 201201  
Country: P. R. China  
Contact: Xu Kai  
Telephone: +86-021-50791141/2/3  
Fax: +86-021-50791141/2/3-8000  
Website: <http://www.ta-shanghai.com>  
E-mail: [xukai@ta-shanghai.com](mailto:xukai@ta-shanghai.com)

## 2. General Description of Equipment under Test

### Client Information

<b>Applicant</b>	Huawei Technologies Co., Ltd.
<b>Applicant address</b>	Administration Building, Headquarters of Huawei Technologies Co., Ltd., Bantian, Longgang District, Shenzhen, 518129, P.R.China
<b>Manufacturer</b>	Huawei Technologies Co., Ltd.
<b>Manufacturer address</b>	Administration Building, Headquarters of Huawei Technologies Co., Ltd., Bantian, Longgang District, Shenzhen, 518129, P.R.China

### General information

EUT Description			
Model:	eAN3810A		
SN:	2102311RKU10GA800040		
Hardware Version:	eAN3810A V100		
Software Version:	eAN3810A V100		
Power Supply:	AC Power Supply		
Antenna Type:	Omni-directional		
Antenna Gain:	ANT1= ANT2= ANT3= ANT4=5dBi		
Directional Gain:	8dBi		
Test Mode:	5725 MHz - 5850 MHz		
Modulation Type:	OFDM		
Max. Conducted Power	27.44 dBm		
Operating Frequency Range(s)	Mode	Tx (MHz)	Rx (MHz)
	5G	5725 - 5850	5725 - 5850
EUT Accessory			
Adapter	Manufacture: PSP Model : POE85-56A		
Note: The information of the EUT is declared by the manufacturer. Please refer to the specifications or user manual for details.			



### 3. Test Information

According to the specifications of the manufacturer, it must comply with the requirements of the following standards:

**FCC CFR47 Part 15E (2017) Unlicensed National Information Infrastructure Devices**

**ANSI C63.10 (2013)**

**KDB 789033 D02 General UNII Test Procedures New Rules v01r04**

**KDB 662911 D01 Multiple Transmitter Output v02r01**

## 4. Test Configuration

### Test Mode

The EUT was programmed to be in continuously transmitting mode and the transmit duty cycle is not less than 98%.

The EUT has been associated with peripherals and configuration operated in a manner tended to maximize its emission characteristics in a typical application.

The radiated emission was measured in the following position: EUT stand-up position (Z axis), lie-down position (X, Y axis). The worst emission was found in stand-up position (Z axis) and the worst case was recorded.

In order to find the worst case condition, Pre-tests are needed at the presence of different data rate. Preliminary tests have been done on all the configuration and all antennas for confirming worst case. Data rate below means worst-case rate of each test item.

Test Mode	Modulation Type
TM1	QPSK
TM2	16QAM
TM3	64QAM
The device can not work alone in the BPSK modulation mode, when we test QPSK, 16QAM, 64QAM, a small number of OFDM symbols using BPSK modulation and not fixed	

The worst case Antenna mode for each of the following tests:

Test Cases	Antenna 1	Antenna 2	Antenna 3	Antenna 4	MIMO
Maximum peak conducted output power	TM1/ TM2/ TM3	TM1/ TM2/ TM3	TM1/ TM2/ TM3	TM1/ TM2/ TM3	TM1/ TM2/ TM3
Occupied bandwidth	TM1/ TM2/ TM3	TM1/ TM2/ TM3	TM1/ TM2/ TM3	TM1/ TM2/ TM3	--
Frequency stability	TM3	TM3	TM3	TM3	--
Maximum power spectral density	TM1/ TM2/ TM3	TM1/ TM2/ TM3	TM1/ TM2/ TM3	TM1/ TM2/ TM3	TM1/ TM2/ TM3
Unwanted Emissions	--	--	--	--	TM3
Conducted spurious emission at antenna port	TM3	TM3	TM3	TM3	--
Conducted Emissions	TM3	--	--	--	--



## 5. Test Case Results

### 5.1. Occupied Bandwidth

#### Ambient condition

Temperature	Relative humidity	Pressure
23°C ~25°C	45%~50%	101.5kPa

#### Method of Measurement

The EUT was connected to the spectrum analyzer through an external attenuator (20dB) and a known loss cable.

Set RBW = 100 kHz, VBW  $\geq 3 \times$  RBW, measure the maximum width of the emission that is constrained by the frequencies associated with the two outermost amplitude points (upper and lower frequencies) that are attenuated by 6 dB relative to the maximum level measured in the fundamental emission.

Set RBW = 1 % to 5 % of the OBW, VBW  $\geq 3 \times$  RBW, Use the 99 % power bandwidth function of the instrument (if available).

If the instrument does not have a 99 % power bandwidth function, the trace data points are recovered and directly summed in power units. The recovered amplitude data points, beginning at the lowest frequency, are placed in a running sum until 0.5 % of the total is reached; that frequency is recorded as the lower frequency. The process is repeated until 99.5 % of the total is reached; that frequency is recorded as the upper frequency. The 99% occupied bandwidth is the difference between these two frequencies.

#### Test Setup

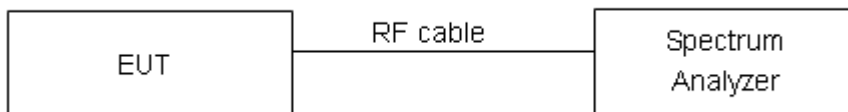

#### Limits

Rule FCC Part §15.407(e)

Within the 5.725-5.85 GHz band, the minimum 6 dB bandwidth of U-NII devices shall be at least 500 kHz.

#### Measurement Uncertainty

The assessed measurement uncertainty to ensure 95% confidence level for the normal distribution is with the coverage factor  $k = 2$ ,  $U = 936$  Hz.

**Test Results:****TM1**

Antenna	Carrier frequency (MHz)	99% bandwidth (MHz)	Minimum -6 dB bandwidth (MHz)	Limit (kHz)	Conclusion
Antenna 1	5735	17.875	17.96	500	PASS
	5790	17.823	17.97	500	PASS
	5840	17.922	17.98	500	PASS
Antenna 2	5735	17.872	17.97	500	PASS
	5790	17.879	17.98	500	PASS
	5840	17.849	17.99	500	PASS
Antenna 3	5735	17.840	18.01	500	PASS
	5790	17.878	17.67	500	PASS
	5840	17.867	17.97	500	PASS
Antenna 4	5735	17.892	17.95	500	PASS
	5790	17.934	17.90	500	PASS
	5840	17.896	18.00	500	PASS

**TM2**

Antenna	Carrier frequency (MHz)	99% bandwidth (MHz)	Minimum -6 dB bandwidth (MHz)	Limit (kHz)	Conclusion
Antenna 1	5735	17.834	18.00	500	PASS
	5790	17.858	17.97	500	PASS
	5840	17.833	17.96	500	PASS
Antenna 2	5735	17.842	18.04	500	PASS
	5790	17.866	18.02	500	PASS
	5840	17.796	17.99	500	PASS
Antenna 3	5735	17.854	17.26	500	PASS
	5790	17.893	17.73	500	PASS
	5840	17.865	17.96	500	PASS
Antenna 4	5735	17.898	18.02	500	PASS
	5790	17.895	17.98	500	PASS
	5840	17.853	18.02	500	PASS



## TM3

Antenna	Carrier frequency (MHz)	99% bandwidth (MHz)	Minimum -6 dB bandwidth (MHz)	Limit (kHz)	Conclusion
Antenna 1	5735	17.895	18.01	500	PASS
	5790	17.885	18.00	500	PASS
	5840	17.865	18.03	500	PASS
Antenna 2	5735	17.930	18.00	500	PASS
	5790	17.921	18.00	500	PASS
	5840	17.911	18.04	500	PASS
Antenna 3	5735	17.863	18.03	500	PASS
	5790	17.839	18.03	500	PASS
	5840	17.846	17.99	500	PASS
Antenna 4	5735	17.891	18.03	500	PASS
	5790	17.896	17.99	500	PASS
	5840	17.885	18.00	500	PASS



TM1

Antenna 1

99% bandwidth, Carrier frequency (MHz): 5735

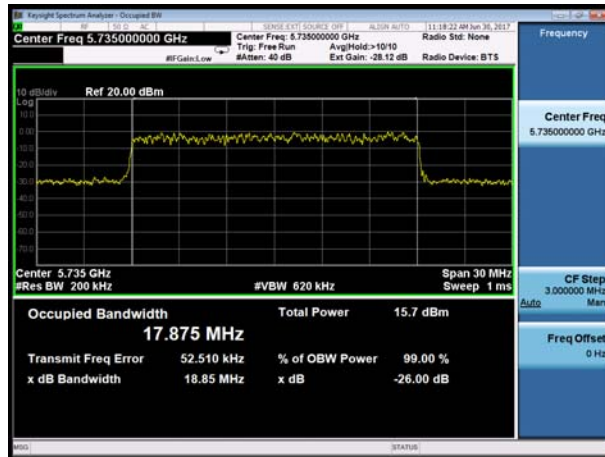

-6dB bandwidth, Carrier frequency (MHz): 5735



99% bandwidth, Carrier frequency (MHz): 5790

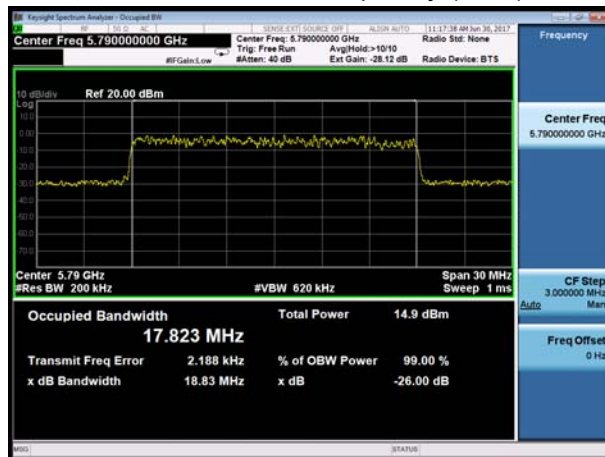

-6dB bandwidth, Carrier frequency (MHz): 5790



99% bandwidth, Carrier frequency (MHz): 5840

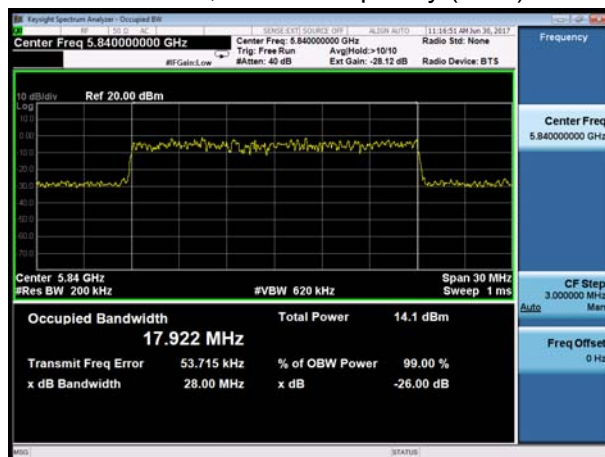

-6dB bandwidth, Carrier frequency (MHz): 5840

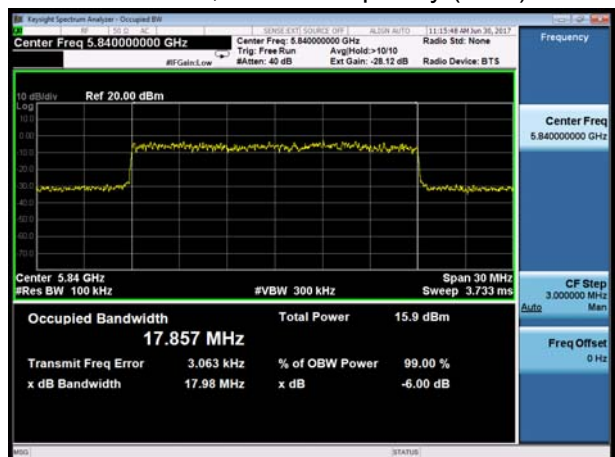



Antenna 2

99% bandwidth, Carrier frequency (MHz): 5735



-6dB bandwidth, Carrier frequency (MHz): 5735

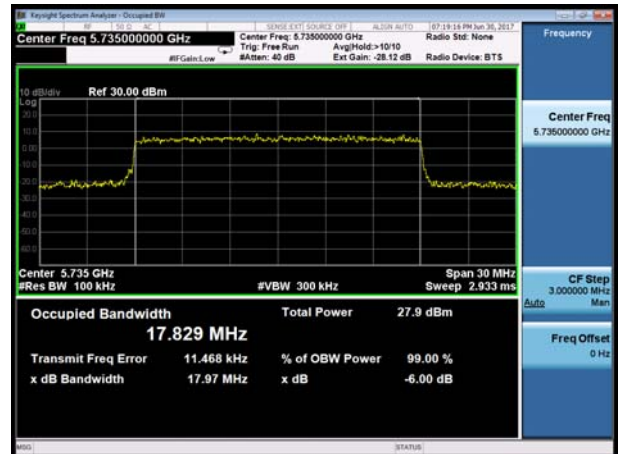

99% bandwidth, Carrier frequency (MHz): 5790



-6dB bandwidth, Carrier frequency (MHz): 5790



99% bandwidth, Carrier frequency (MHz): 5840



-6dB bandwidth, Carrier frequency (MHz): 5840





Antenna 3

99% bandwidth, Carrier frequency (MHz): 5735



-6dB bandwidth, Carrier frequency (MHz): 5735

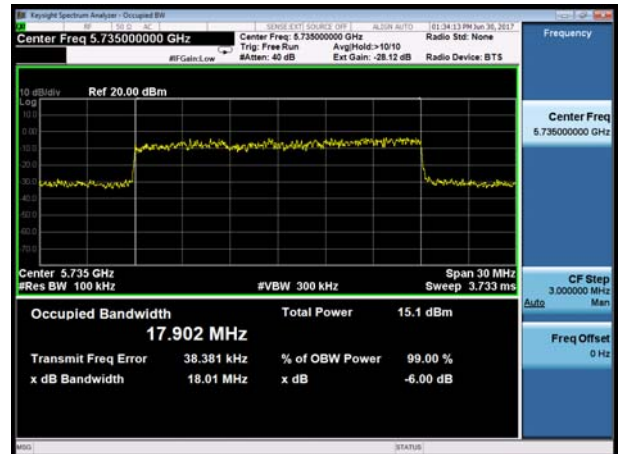

99% bandwidth, Carrier frequency (MHz): 5790



-6dB bandwidth, Carrier frequency (MHz): 5790

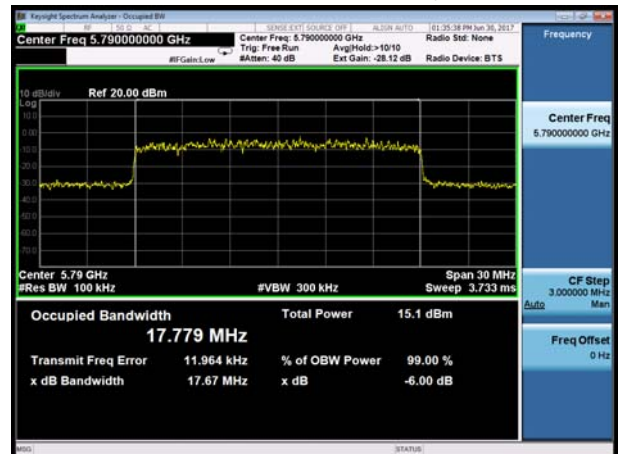

99% bandwidth, Carrier frequency (MHz): 5840



-6dB bandwidth, Carrier frequency (MHz): 5840





Antenna 4

99% bandwidth, Carrier frequency (MHz): 5735



-6dB bandwidth, Carrier frequency (MHz): 5735

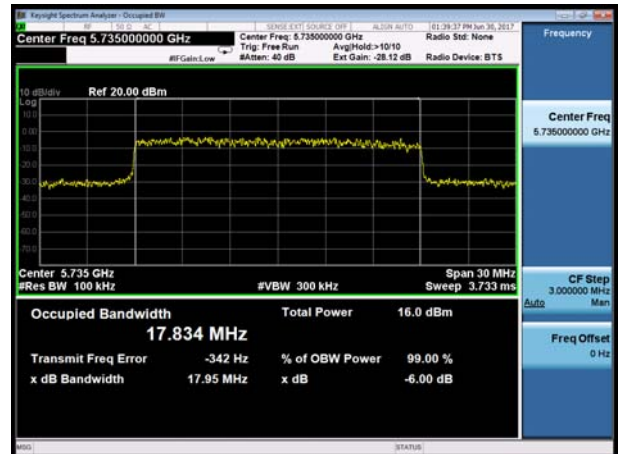

99% bandwidth, Carrier frequency (MHz): 5790

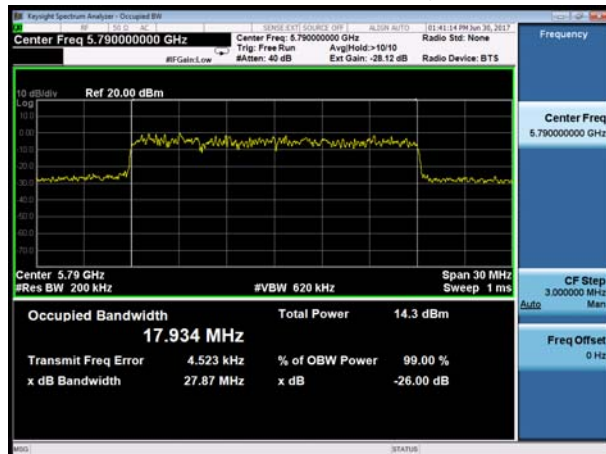

-6dB bandwidth, Carrier frequency (MHz): 5790

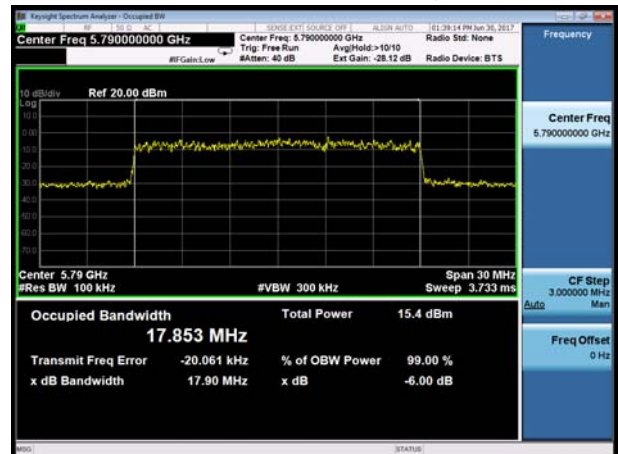

99% bandwidth, Carrier frequency (MHz): 5840

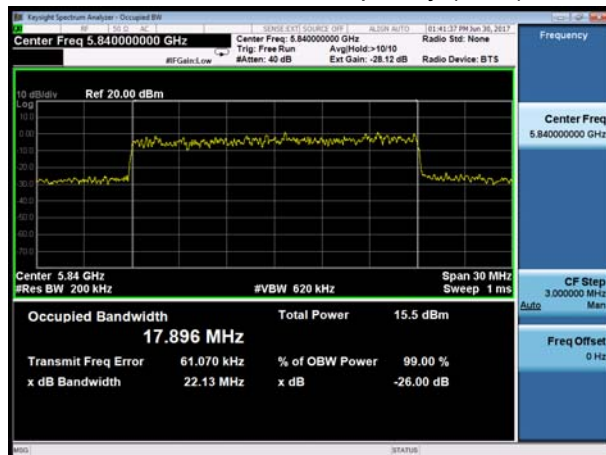

-6dB bandwidth, Carrier frequency (MHz): 5840





TM2

Antenna 1

99% bandwidth, Carrier frequency (MHz): 5735



-6dB bandwidth, Carrier frequency (MHz): 5735



99% bandwidth, Carrier frequency (MHz): 5790



-6dB bandwidth, Carrier frequency (MHz): 5790



99% bandwidth, Carrier frequency (MHz): 5840

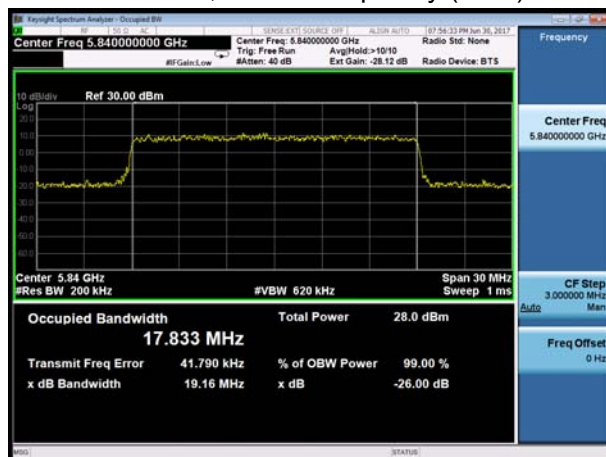

-6dB bandwidth, Carrier frequency (MHz): 5840

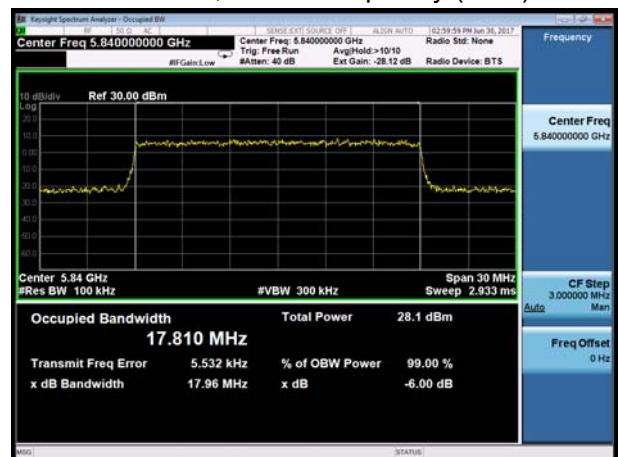





Antenna 2

99% bandwidth, Carrier frequency (MHz): 5735



-6dB bandwidth, Carrier frequency (MHz): 5735



99% bandwidth, Carrier frequency (MHz): 5790



-6dB bandwidth, Carrier frequency (MHz): 5790

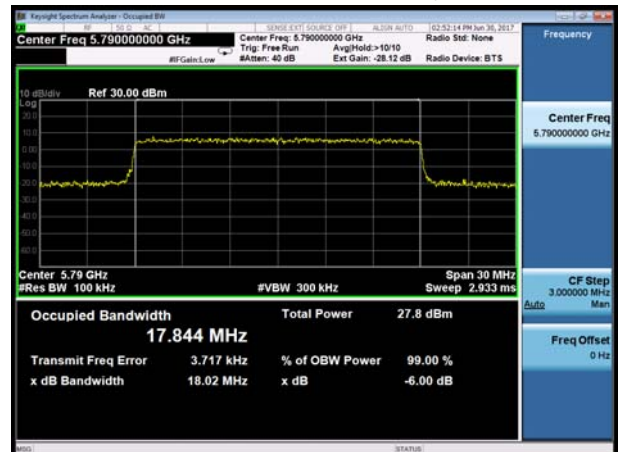

99% bandwidth, Carrier frequency (MHz): 5840



-6dB bandwidth, Carrier frequency (MHz): 5840

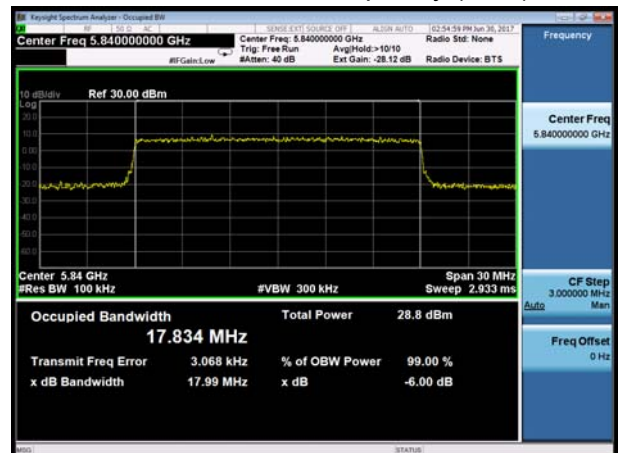



Antenna 3

99% bandwidth, Carrier frequency (MHz): 5735

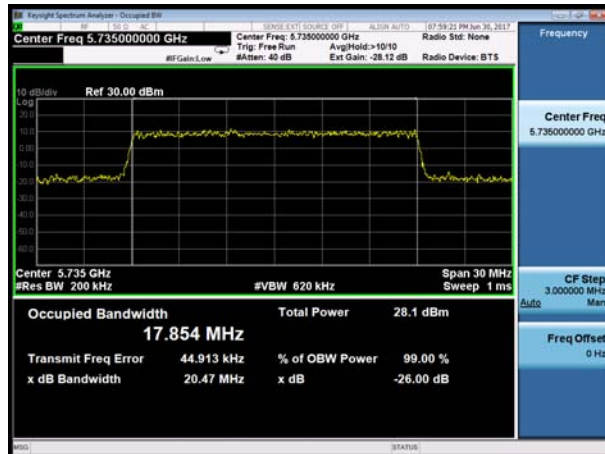

-6dB bandwidth, Carrier frequency (MHz): 5735

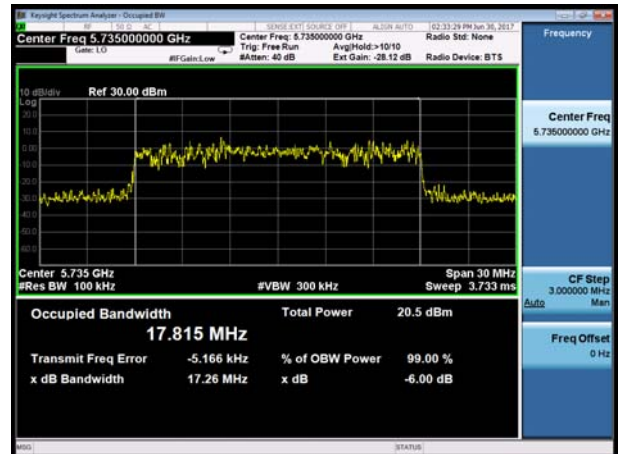

99% bandwidth, Carrier frequency (MHz): 5790

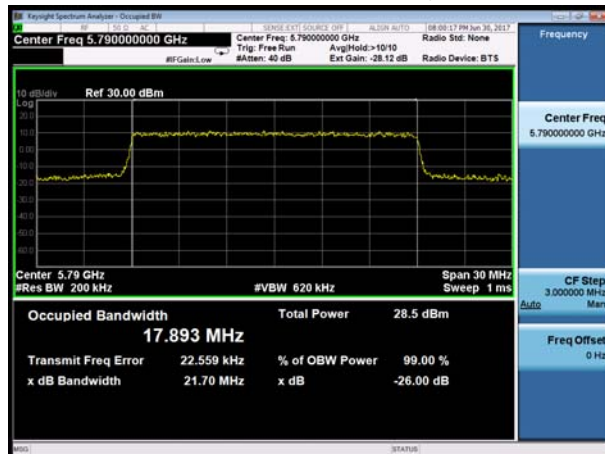

-6dB bandwidth, Carrier frequency (MHz): 5790

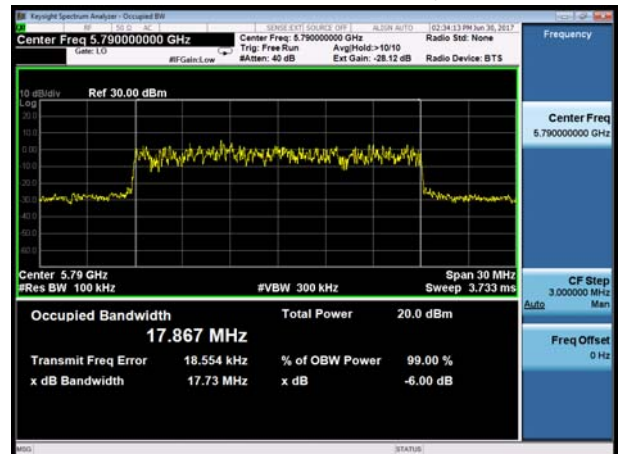

99% bandwidth, Carrier frequency (MHz): 5840



-6dB bandwidth, Carrier frequency (MHz): 5840

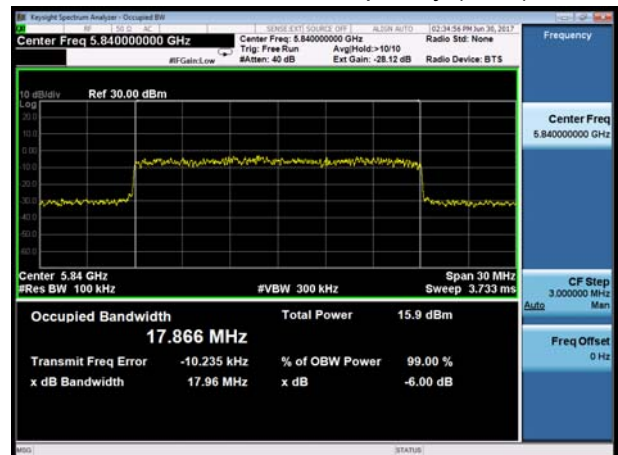



### Antenna 4

99% bandwidth, Carrier frequency (MHz): 5735



-6dB bandwidth, Carrier frequency (MHz): 5735



99% bandwidth, Carrier frequency (MHz): 5790



-6dB bandwidth, Carrier frequency (MHz): 5790

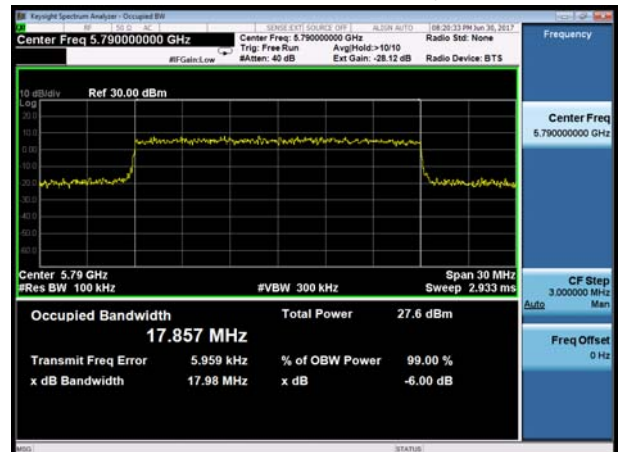

99% bandwidth, Carrier frequency (MHz): 5840



-6dB bandwidth, Carrier frequency (MHz): 5840

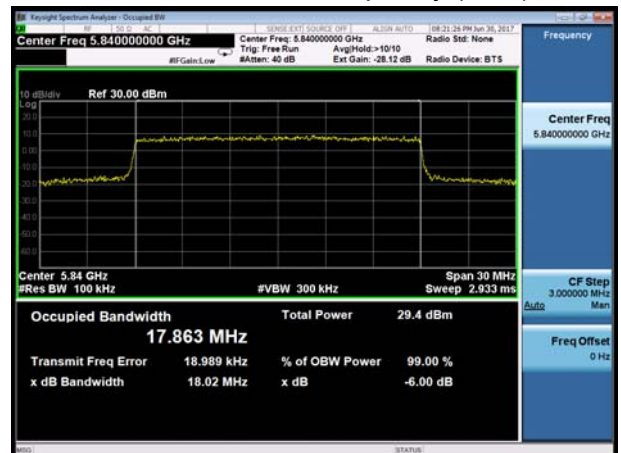



TM3

Antenna 1

99% bandwidth, Carrier frequency (MHz): 5735



-6dB bandwidth, Carrier frequency (MHz): 5735



99% bandwidth, Carrier frequency (MHz): 5790



-6dB bandwidth, Carrier frequency (MHz): 5790



99% bandwidth, Carrier frequency (MHz): 5840



-6dB bandwidth, Carrier frequency (MHz): 5840

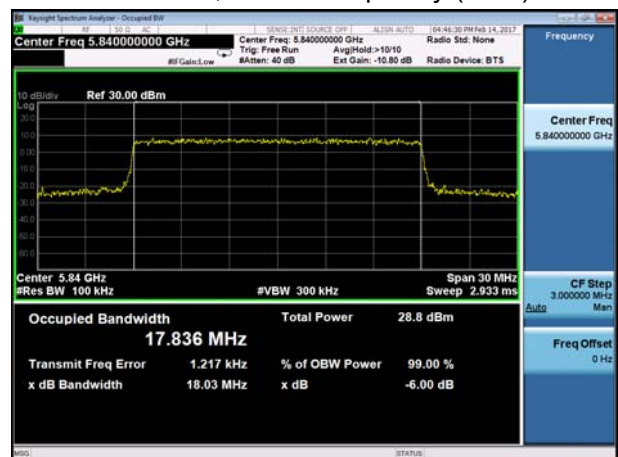



Antenna 2

99% bandwidth, Carrier frequency (MHz): 5735



-6dB bandwidth, Carrier frequency (MHz): 5735



99% bandwidth, Carrier frequency (MHz): 5790



-6dB bandwidth, Carrier frequency (MHz): 5790



99% bandwidth, Carrier frequency (MHz): 5840



-6dB bandwidth, Carrier frequency (MHz): 5840

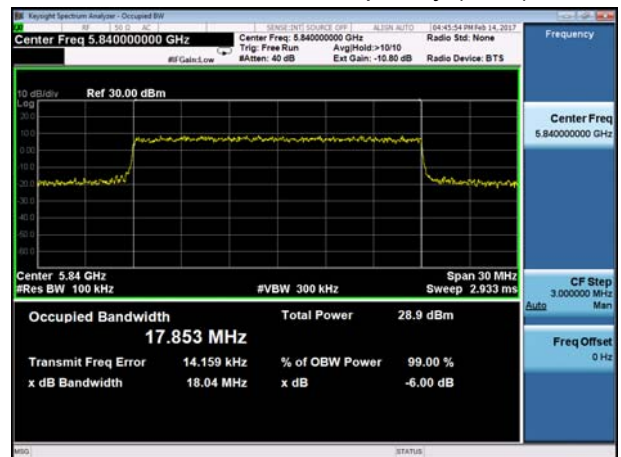



Antenna 3

99% bandwidth, Carrier frequency (MHz): 5735



-6dB bandwidth, Carrier frequency (MHz): 5735



99% bandwidth, Carrier frequency (MHz): 5790



-6dB bandwidth, Carrier frequency (MHz): 5790



99% bandwidth, Carrier frequency (MHz): 5840



-6dB bandwidth, Carrier frequency (MHz): 5840

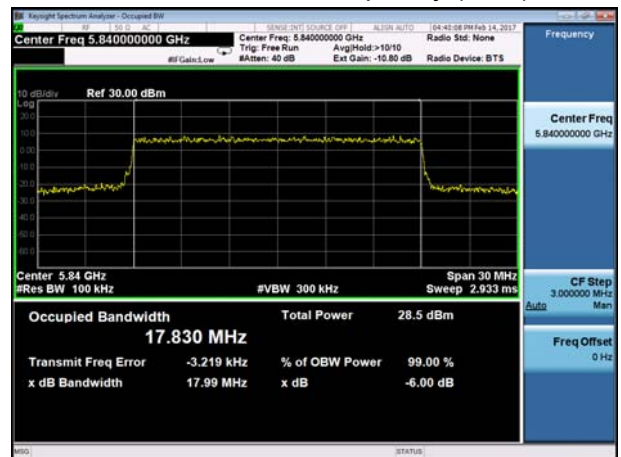



Antenna 4

99% bandwidth, Carrier frequency (MHz): 5735



-6dB bandwidth, Carrier frequency (MHz): 5735



99% bandwidth, Carrier frequency (MHz): 5790

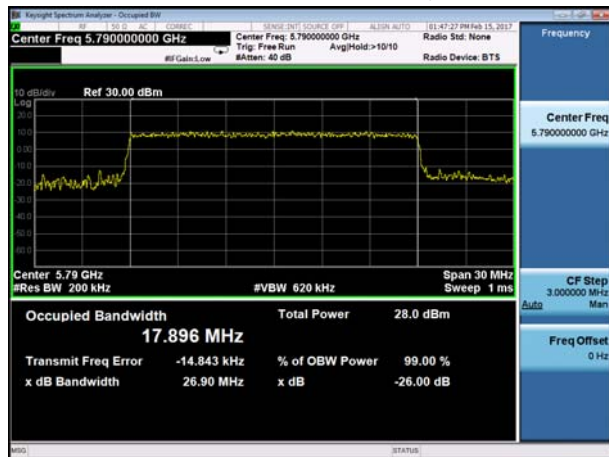

-6dB bandwidth, Carrier frequency (MHz): 5790



99% bandwidth, Carrier frequency (MHz): 5840

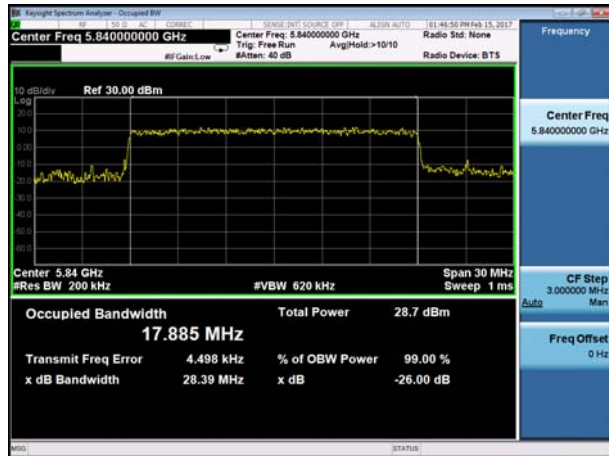

-6dB bandwidth, Carrier frequency (MHz): 5840



## 5.2. Power Output –Conducted

### Ambient condition

Temperature	Relative humidity	Pressure
23°C ~25°C	45%~50%	101.5kPa

### Methods of Measurement

During the process of the testing, The EUT was connected to the average power meter through an external attenuator and a known loss cable. The EUT is max power transmission with proper modulation. We use Maximum average Conducted Output Power Level Method in KDB789033 for this test.

The conducted Power is measured at each antenna port. The measured results at the various antenna ports are then summed mathematically.

### Test Setup

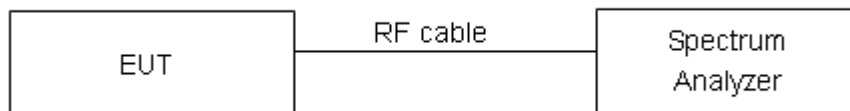

### Limits

Rule FCC Part 15.407(a)(3)

For the band 5.725-5.85 GHz, the maximum conducted output power over the frequency band of operation shall not exceed 1 W. In addition, the maximum power spectral density shall not exceed 30 dBm in any 500-kHz band. If transmitting antennas of directional gain greater than 6 dBi are used, both the maximum conducted output power and the maximum power spectral density shall be reduced by the amount in dB that the directional gain of the antenna exceeds 6 dBi.

### Measurement Uncertainty

The assessed measurement uncertainty to ensure 95% confidence level for the normal distribution is with the coverage factor  $k = 2$ ,  $U = 0.44$  dB.



**Test Results**

**TM1**

Antenna	Frequency (MHz)	Average Output Power (dBm)	Limit (dBm)	Conclusion
Antenna 1	5735	20.56	30.00	PASS
	5790	20.53	30.00	PASS
	5840	20.44	30.00	PASS
Antenna 2	5735	20.38	30.00	PASS
	5790	19.72	30.00	PASS
	5840	20.75	30.00	PASS
Antenna 3	5735	20.03	30.00	PASS
	5790	20.17	30.00	PASS
	5840	20.70	30.00	PASS
Antenna 4	5735	20.77	30.00	PASS
	5790	20.15	30.00	PASS
	5840	20.66	30.00	PASS

Frequency (MHz)	Average Output Power (dBm)										Limit (dBm)	Conclusion
	Antenna 1		Antenna 2		Antenna 3		Antenna 4		MIMO			
	(dBm)	(mW)	(dBm)	(mW)	(dBm)	(mW)	(dBm)	(mW)	(mW)	(dBm)		
5735	20.56	113.76	20.38	109.14	20.03	100.69	20.77	119.40	443.00	26.46	28.00	PASS
5790	20.53	112.98	19.72	93.76	20.17	103.99	20.15	103.51	414.24	26.17	28.00	PASS
5840	20.44	110.66	20.75	118.85	20.70	117.49	20.66	116.41	463.42	26.66	28.00	PASS

Note:1.For MIMO mode,according to KDB 662911 D01 Multiple Transmitter Output v02r01 1), the average output power= $10\log(10^{(\text{Power antenna1 in dBm}/10)}+10^{(\text{Power antenna2 in dBm}/10)}+10^{(\text{Power antenna3 in dBm}/10)}+10^{(\text{Power antenna4 in dBm}/10)})$

2. For MIMO mode, the manufacturer declared the transmitter output signals are SFBC modes combine with CDD modes.The signals are antenna 1,2 correlated and 3,4 correlated. And 1,2 and 3,4 are completely uncorrelated.According to KDB 662911 D01 Multiple Transmitter Output v02r01 2)a)(i):If any transmit signals are correlated with each other,Directional gain =  $GANT + 10 \log(NANT)$  dBi= $5+10\log(2)=8\text{dBi}>6\text{dBi}$ .So the power limit shall be reduced to  $30-(8-6)=28\text{dBm}$ .

TM2

Antenna	Frequency (MHz)	Average Output Power (dBm)	Limit (dBm)	Conclusion
Antenna 1	5735	20.62	30.00	PASS
	5790	20.34	30.00	PASS
	5840	20.54	30.00	PASS
Antenna 2	5735	20.35	30.00	PASS
	5790	19.93	30.00	PASS
	5840	20.91	30.00	PASS
Antenna 3	5735	20.67	30.00	PASS
	5790	20.19	30.00	PASS
	5840	20.81	30.00	PASS
Antenna 4	5735	21.02	30.00	PASS
	5790	20.54	30.00	PASS
	5840	20.84	30.00	PASS

Frequency (MHz)	Average Output Power (dBm)										Limit (dBm)	Conclusion
	Antenna 1		Antenna 2		Antenna 3		Antenna 4		MIMO			
	(dBm)	(mW)	(dBm)	(mW)	(dBm)	(mW)	(dBm)	(mW)	(mW)	(dBm)		
5735	20.62	115.35	20.35	108.39	20.67	116.68	21.02	126.47	466.89	26.69	28.00	PASS
5790	20.34	108.14	19.93	98.40	20.19	104.47	20.54	113.24	424.25	26.28	28.00	PASS
5840	20.54	113.24	20.91	123.31	20.81	120.50	20.84	121.34	478.39	26.80	28.00	PASS

Note:1.For MIMO mode,according to KDB 662911 D01 Multiple Transmitter Output v02r01 1), the average output power= $10\log(10^{(\text{Power antenna1 in dBm}/10)}+10^{(\text{Power antenna2 in dBm}/10)}+10^{(\text{Power antenna3 in dBm}/10)}+10^{(\text{Power antenna4 in dBm}/10)})$

2. For MIMO mode, the manufacturer declared the transmitter output signals are SFBC modes combine with CDD modes.The signals are antenna 1,2 correlated and 3,4 correlated. And 1,2 and 3,4 are completely uncorrelated.According to KDB 662911 D01 Multiple Transmitter Output v02r01 2)a)(i):If any transmit signals are correlated with each other,Directional gain =  $GANT + 10 \log(NANT)$  dBi= $5+10\log(2)=8\text{dBi}>6\text{dBi}$ .So the power limit shall be reduced to  $30-(8-6)=28\text{dBm}$ .



## TM3

Antenna	Frequency (MHz)	Average Output Power (dBm)	Limit (dBm)	Conclusion
Antenna 1	5735	20.73	30.00	PASS
	5790	21.19	30.00	PASS
	5840	20.41	30.00	PASS
Antenna 2	5735	21.39	30.00	PASS
	5790	21.05	30.00	PASS
	5840	19.83	30.00	PASS
Antenna 3	5735	21.92	30.00	PASS
	5790	21.47	30.00	PASS
	5840	20.24	30.00	PASS
Antenna 4	5735	21.54	30.00	PASS
	5790	19.88	30.00	PASS
	5840	20.57	30.00	PASS

Frequency (MHz)	Average Output Power (dBm)										Limit (dBm)	Conclusion
	Antenna 1		Antenna 2		Antenna 3		Antenna 4		MIMO			
	(dBm)	(mW)	(dBm)	(mW)	(dBm)	(mW)	(dBm)	(mW)	(mW)	(dBm)		
5735	20.73	118.30	21.39	137.72	21.92	155.60	21.54	142.56	554.18	27.44	28.00	PASS
5790	21.19	131.52	21.05	127.35	21.47	140.28	19.88	97.27	496.42	26.96	28.00	PASS
5840	20.41	109.90	19.83	96.16	20.24	105.68	20.57	114.02	425.76	26.29	28.00	PASS

Note:1.For MIMO mode,according to KDB 662911 D01 Multiple Transmitter Output v02r01 1), the average output power= $10\log(10^{(\text{Power antenna1 in dBm}/10)}+10^{(\text{Power antenna2 in dBm}/10)}+10^{(\text{Power antenna3 in dBm}/10)}+10^{(\text{Power antenna4 in dBm}/10)})$

2. For MIMO mode, the manufacturer declared the transmitter output signals are SFBC modes combine with CDD modes.The signals are antenna 1,2 correlated and 3,4 correlated. And 1,2 and 3,4 are completely uncorrelated.According to KDB 662911 D01 Multiple Transmitter Output v02r01 2)a)(i):If any transmit signals are correlated with each other,Directional gain =  $GANT + 10 \log(NANT)$  dBi= $5+10\log(2)=8\text{dBi}>6\text{dBi}$ .So the power limit shall be reduced to  $30-(8-6)=28\text{dBm}$ .



TM1

Antenna 1

Frequency (MHz): 5735

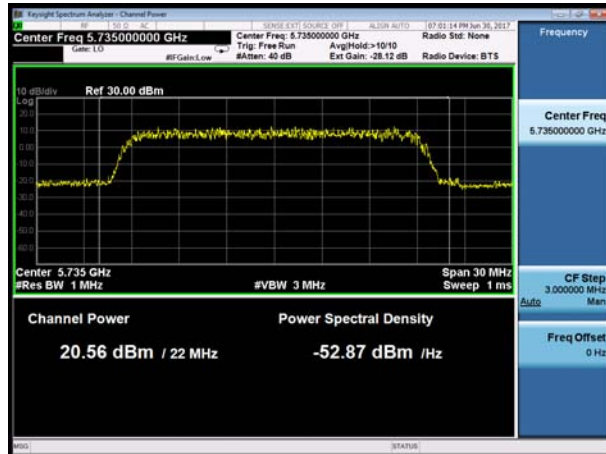

Antenna 2

Frequency (MHz): 5735

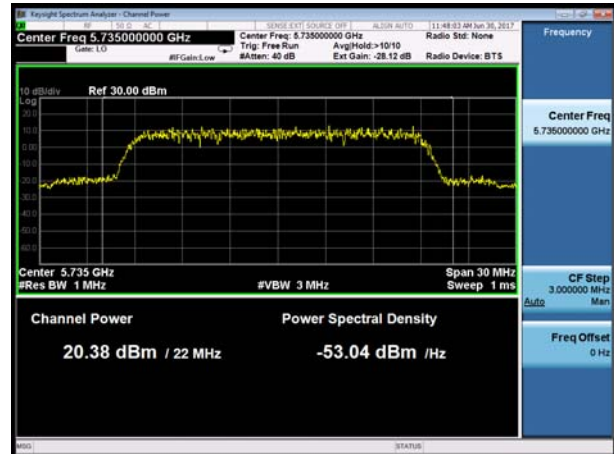

Frequency (MHz): 5790

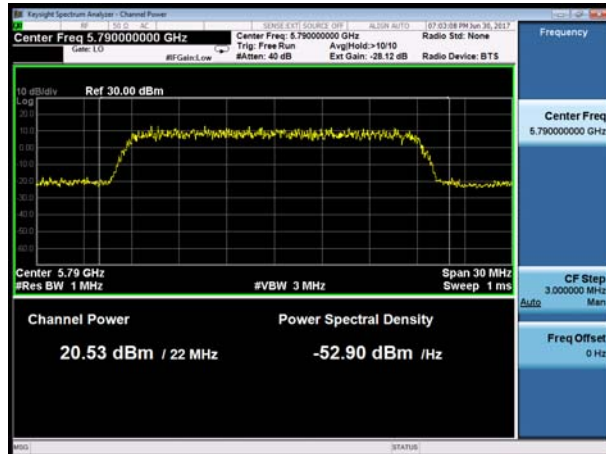

Frequency (MHz): 5790

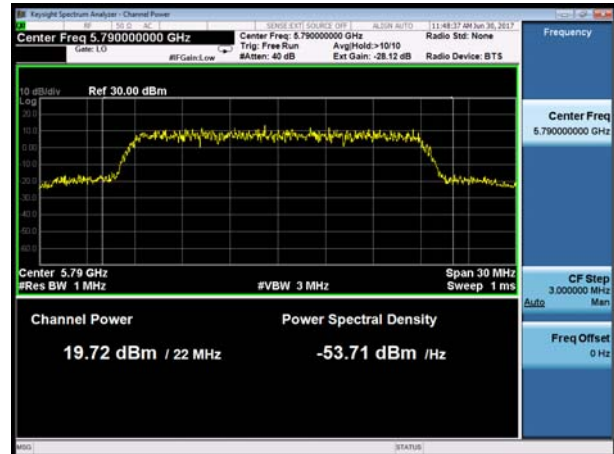

Frequency (MHz): 5840

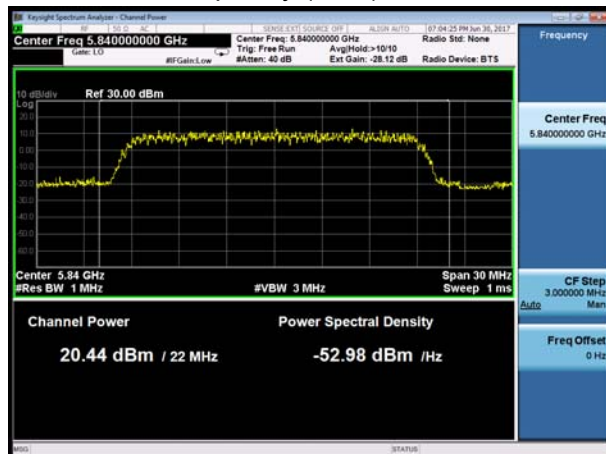

Frequency (MHz): 5840

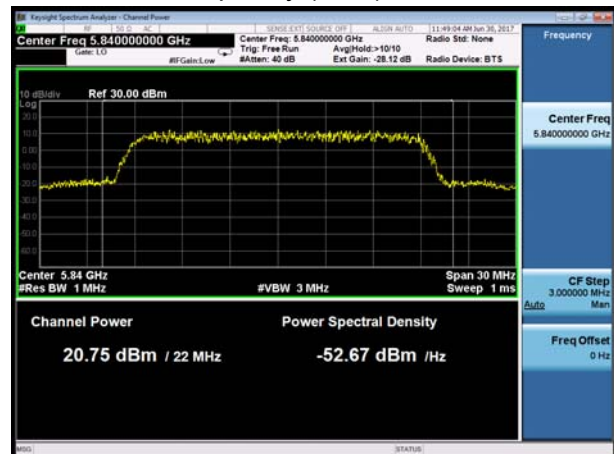



Antenna 3

Frequency (MHz): 5735

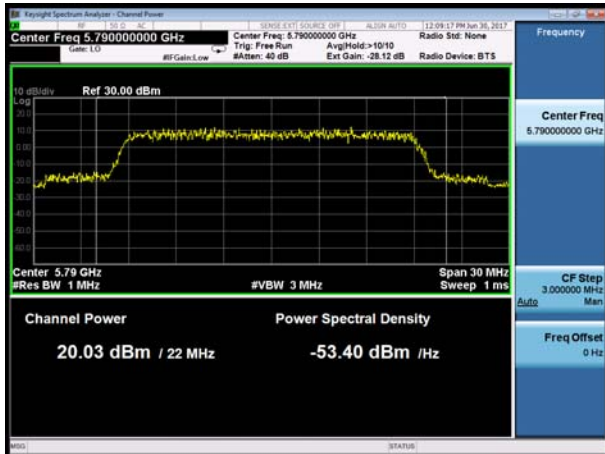

Antenna 4

Frequency (MHz): 5735

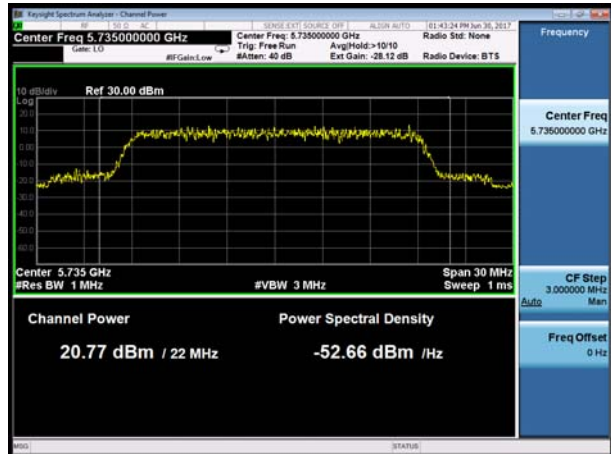

Frequency (MHz): 5790

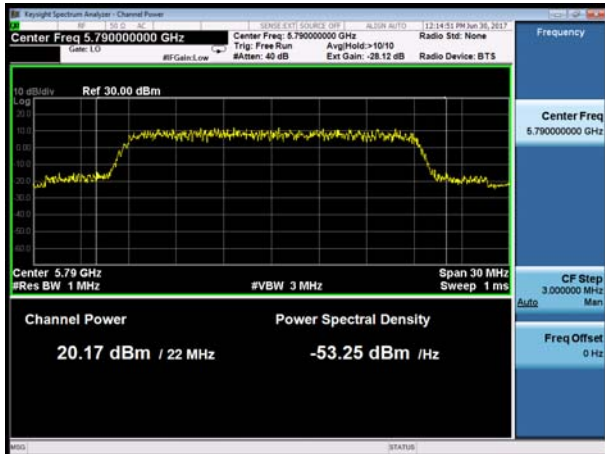

Frequency (MHz): 5790

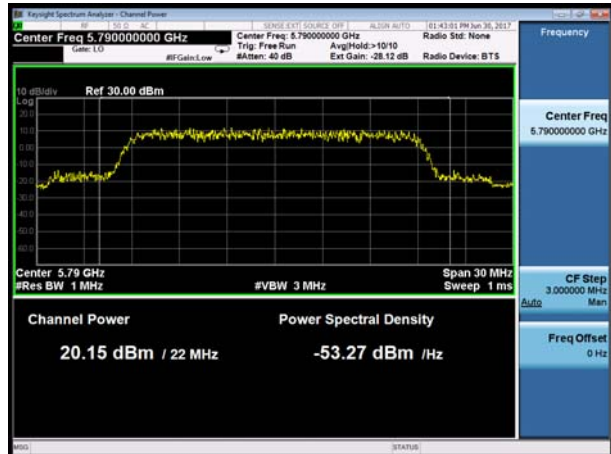

Frequency (MHz): 5840

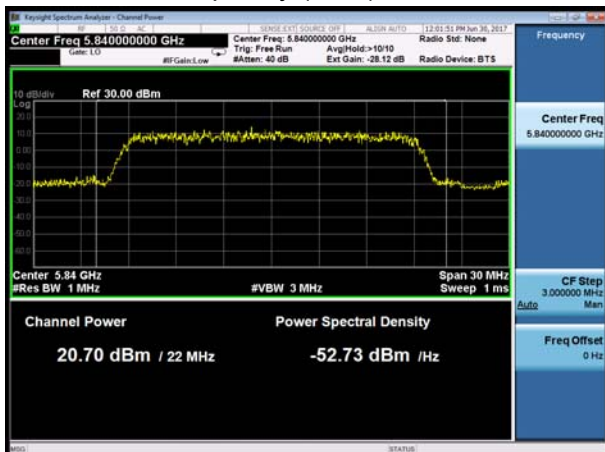

Frequency (MHz): 5840

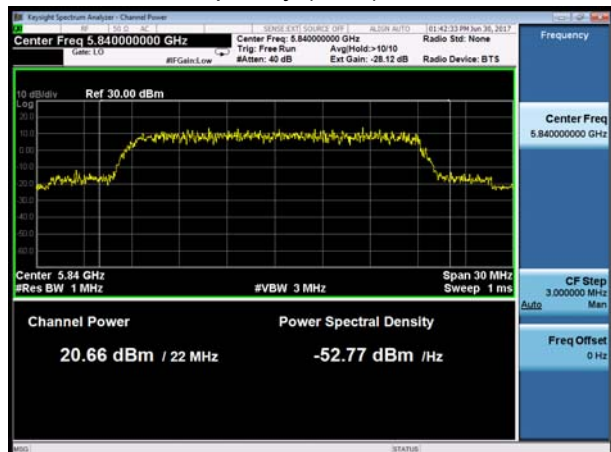



TM2

Antenna 1

Frequency (MHz): 5735

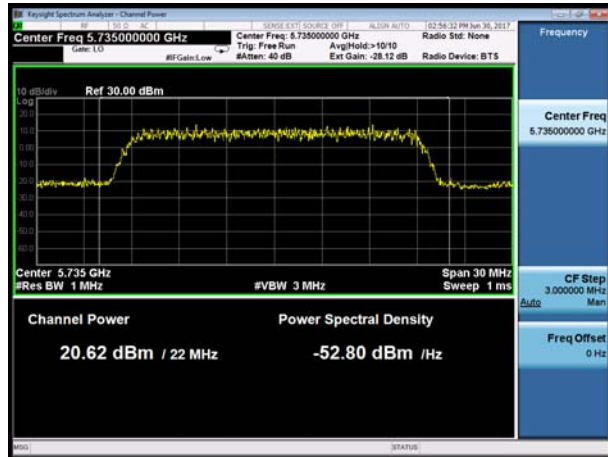

Antenna 2

Frequency (MHz): 5735

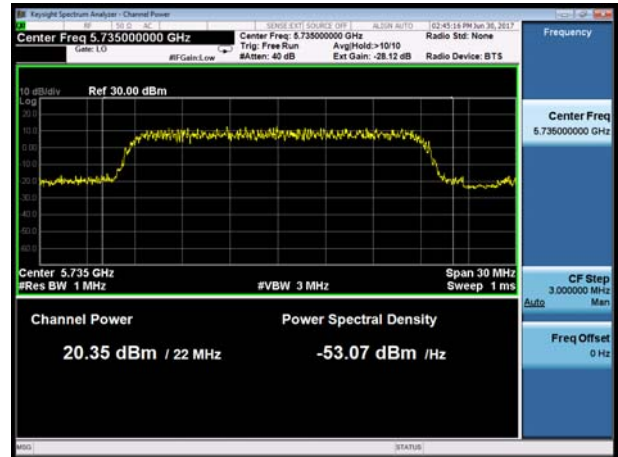

Frequency (MHz): 5790

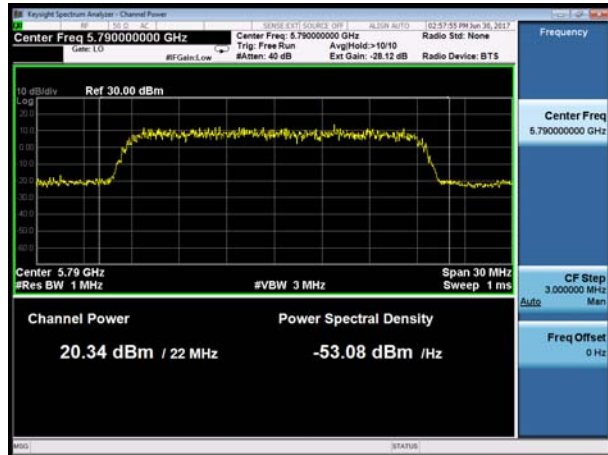

Frequency (MHz): 5790

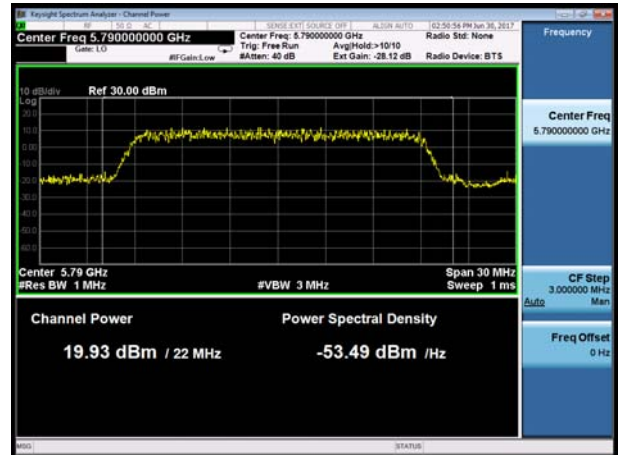

Frequency (MHz): 5840

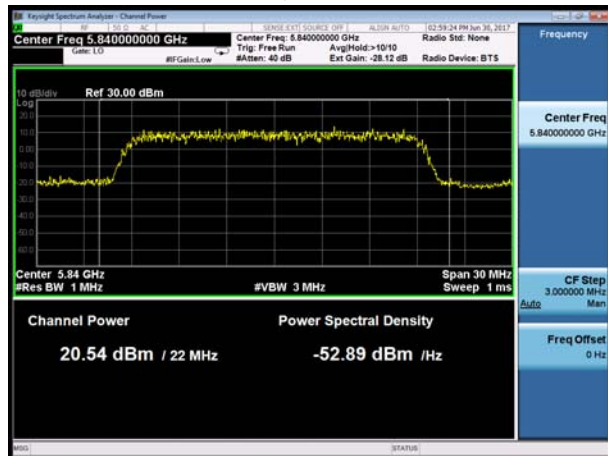

Frequency (MHz): 5840

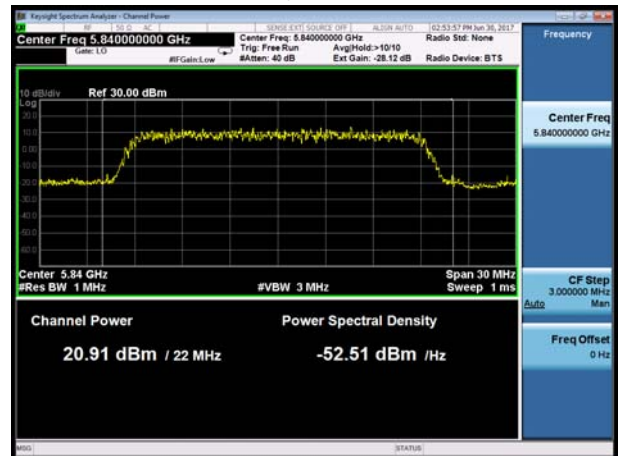

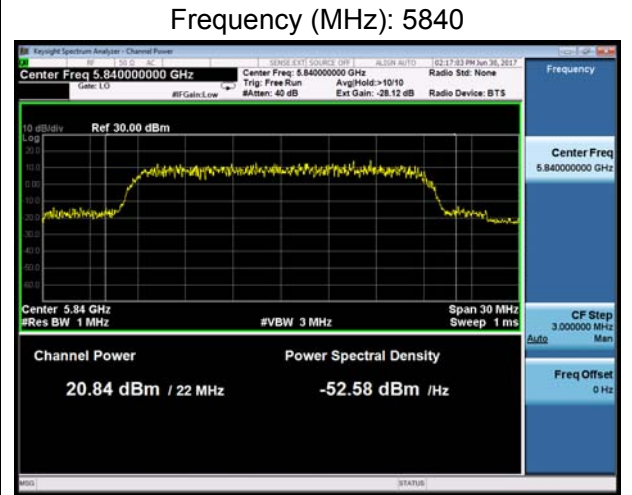
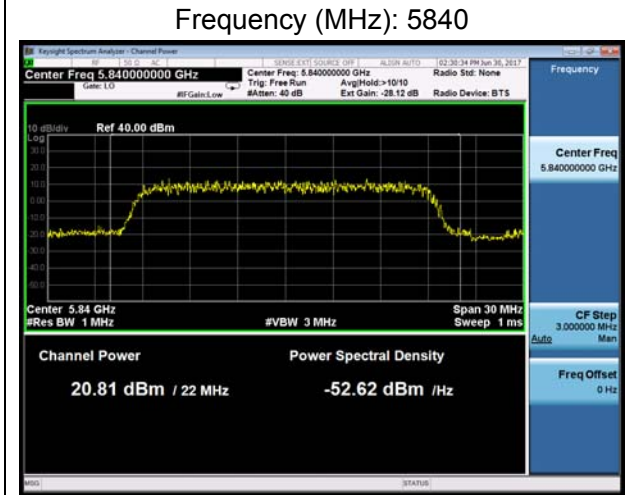
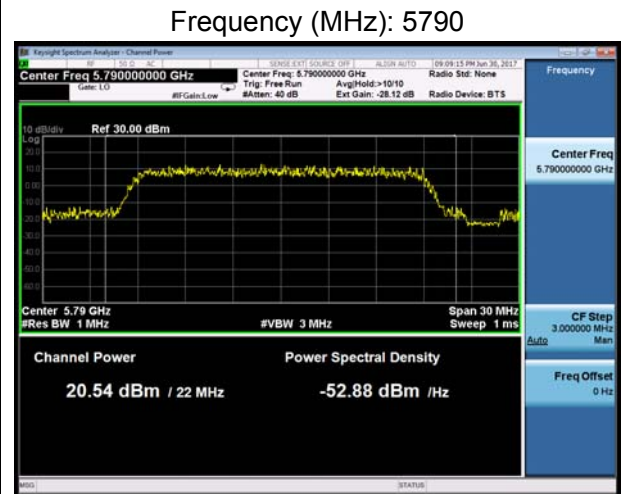
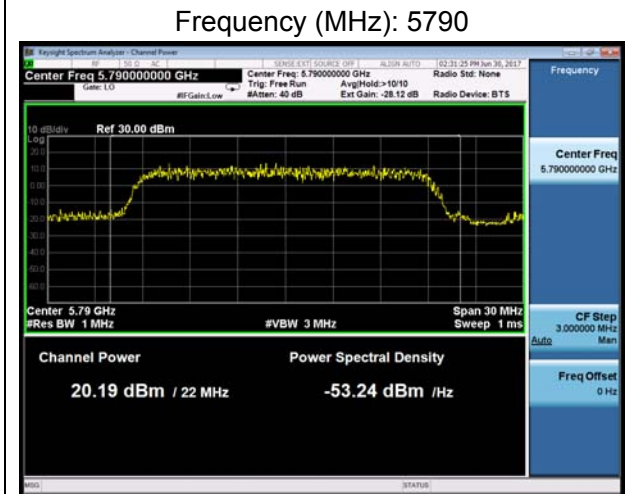
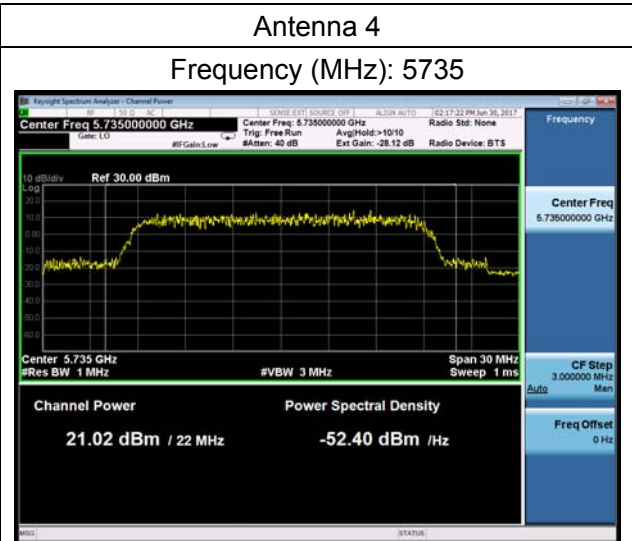
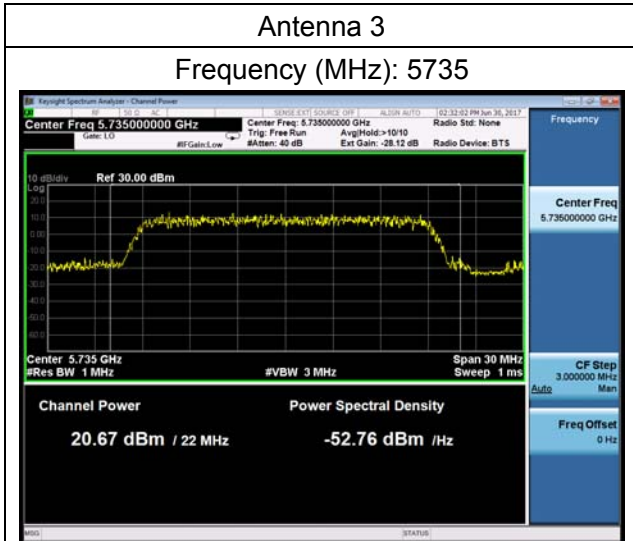



TM3

Antenna 1

Frequency (MHz): 5735



Antenna 2

Frequency (MHz): 5735



Frequency (MHz): 5790

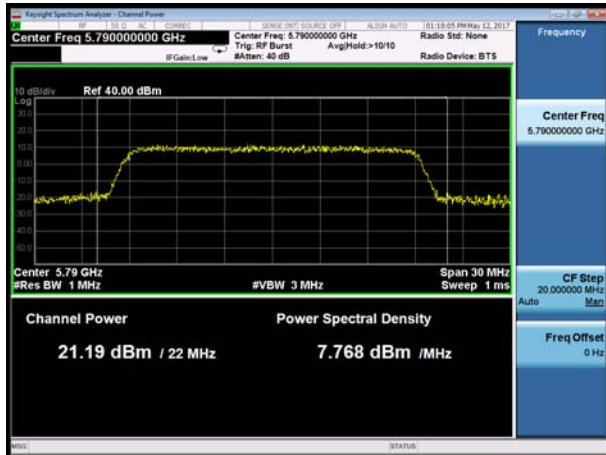

Frequency (MHz): 5790

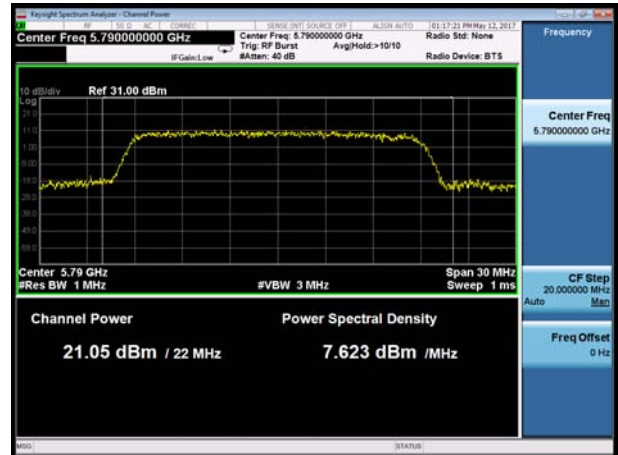

Frequency (MHz): 5840



Frequency (MHz): 5840





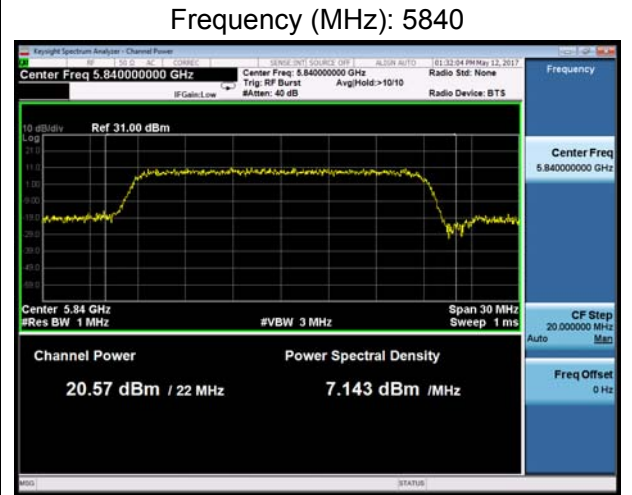
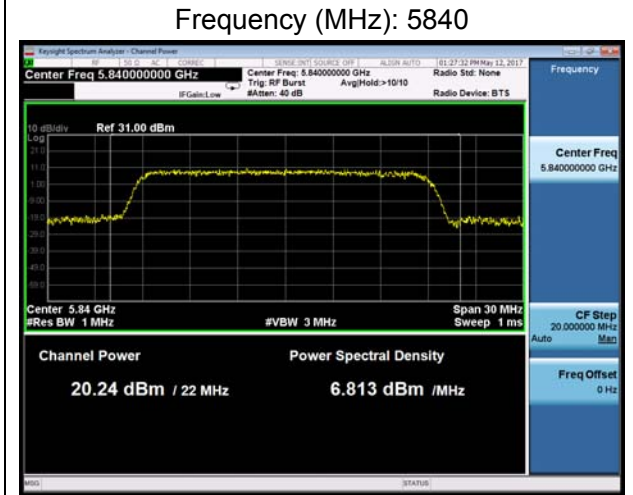
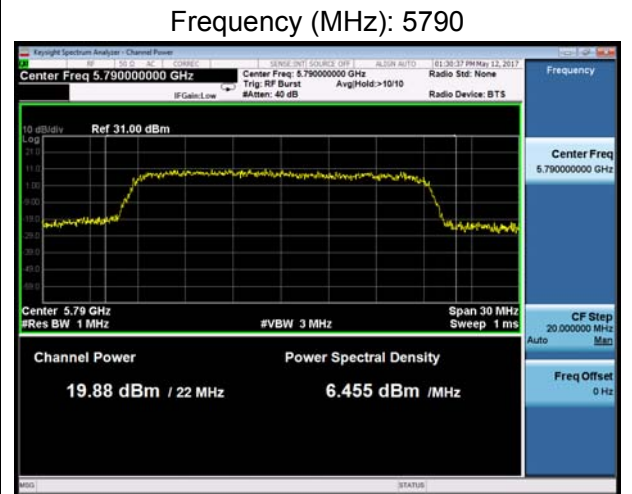
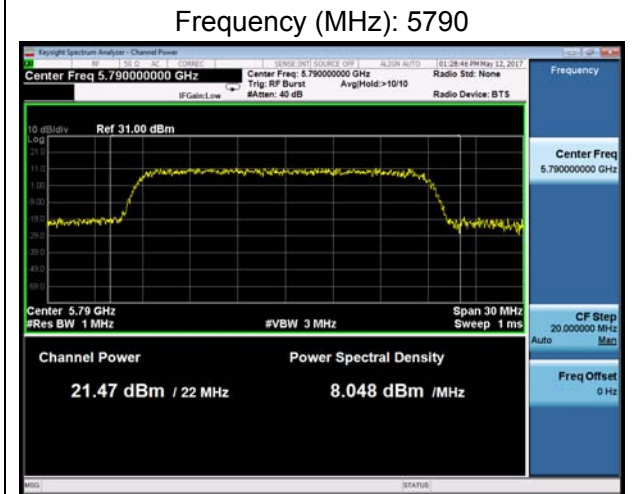
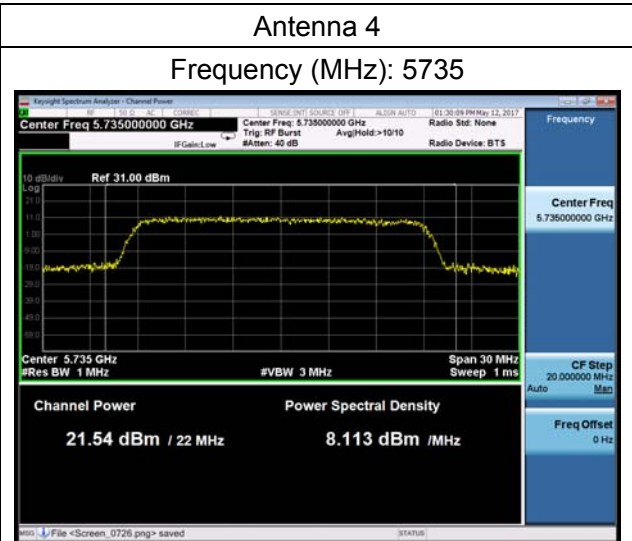
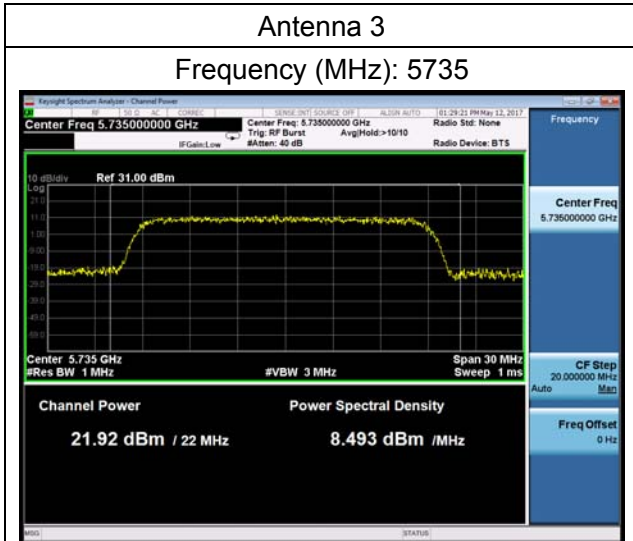

### 5.3. Frequency Stability

#### Ambient condition

Temperature	Relative humidity	Pressure
23°C ~25°C	45%~50%	101.5kPa

#### Method of Measurement

##### 1. Frequency stability with respect to ambient temperature

a) Supply the EUT with a nominal ac voltage or install a new or fully charged battery in the EUT. If possible, a dummy load shall be connected to the EUT because an antenna near the metallic walls of an environmental test chamber could affect the output frequency of the EUT. If the EUT is equipped with a permanently attached, adjustable-length antenna, then the EUT shall be placed in the center of the chamber with the antenna adjusted to the shortest length possible. Turn ON the EUT and tune it to one of the number of frequencies shown in 5.6.

b) Couple the unlicensed wireless device output to the measuring instrument by connecting an antenna to the measuring instrument with a suitable length of coaxial cable and placing the measuring antenna near the EUT (e.g., 15 cm away), or by connecting a dummy load to the measuring instrument, through an attenuator if necessary.

c) Adjust the location of the measurement antenna and the controls on the measurement instrument to obtain a suitable signal level (i.e., a level that will not overload the measurement instrument but is strong enough to allow measurement of the operating or fundamental frequency of the EUT).

d) Turn the EUT OFF and place it inside the environmental temperature chamber. For devices that have oscillator heaters, energize only the heater circuit.

e) Set the temperature control on the chamber to the highest specified in the regulatory requirements for the type of device and allow the oscillator heater and the chamber temperature to stabilize.

f) While maintaining a constant temperature inside the environmental chamber, turn the EUT ON and record the operating frequency at startup, and at 2 minutes, 5 minutes, and 10 minutes after the EUT is energized. Four measurements in total are made.

g) Measure the frequency at each of frequencies specified in 5.6.

h) Switch OFF the EUT but do not switch OFF the oscillator heater.

i) Lower the chamber temperature by not more than 10 C, and allow the temperature inside the chamber to stabilize.

j) Repeat step f) through step i) down to the lowest specified temperature.

##### 2. Frequency stability when varying supply voltage

Unless otherwise specified, these tests shall be made at ambient room temperature (+15 C to +25 C). An antenna shall be connected to the antenna output terminals of the EUT if possible. If the EUT is equipped with or uses an adjustable-length antenna, then it shall be fully extended.

a) Supply the EUT with nominal voltage or install a new or fully charged battery in the EUT. Turn ON the EUT and couple its output to a frequency counter or other frequency-measuring instrument.

- b) Tune the EUT to one of the number of frequencies required in 5.6. Adjust the location of the measurement antenna and the controls on the measurement instrument to obtain a suitable signal level (i.e., a level that will not overload the measurement instrument but is strong enough to allow measurement of the operating or fundamental frequency of the EUT).
- c) Measure the frequency at each of the frequencies specified in 5.6.
- d) Repeat the above procedure at 85% and 115% of the nominal supply voltage.

**Limit**

Manufacturers of U-NII devices are responsible for ensuring frequency stability such that an emission is maintained within the band of operation under all conditions of normal operation as specified in the users manual.

**Measurement Uncertainty**

The assessed measurement uncertainty to ensure 95% confidence level for the normal distribution is with the coverage factor  $k = 2$ ,  $U = 936\text{Hz}$

**Test Results****TM3****Antenna 1**

Voltage (V)	Temperature (°C)	Test Results			
		5735MHz			
		1min	2min	5min	10min
120	-30	5735.004	5734.998	5734.993	5734.992
120	-20	5735.008	5734.999	5734.994	5734.991
120	-10	5735.004	5734.995	5734.992	5734.988
120	0	5735.001	5734.989	5734.992	5734.979
120	10	5734.999	5734.984	5734.988	5734.976
120	20	5734.989	5734.981	5734.978	5734.970
120	30	5734.989	5734.981	5734.974	5734.961
120	40	5734.984	5734.974	5734.974	5734.959
120	50	5734.978	5734.965	5734.967	5734.956
102	20	5734.976	5734.956	5734.963	5734.952
138	20	5734.976	5734.952	5734.954	5734.948
MHz		-0.024	-0.048	-0.046	-0.052
PPM		-4.22861	-8.35061	-8.06881	-9.00112

Voltage (V)	Temperature (°C)	Test Results			
		5790MHz			
		1min	2min	5min	10min
120	-30	5790.006	5790.003	5790.003	5790.007
120	-20	5790.009	5790.003	5790.001	5790.008
120	-10	5790.004	5790.002	5789.993	5790.006
120	0	5790.001	5790.001	5789.986	5790.002
120	10	5789.992	5790.001	5789.981	5789.999
120	20	5789.982	5789.996	5789.976	5789.990
120	30	5789.973	5789.987	5789.967	5789.985
120	40	5789.973	5789.981	5789.962	5789.976
120	50	5789.966	5789.974	5789.957	5789.968
102	20	5789.965	5789.972	5789.951	5789.961
138	20	5789.963	5789.964	5789.945	5789.953
MHz		-0.037	-0.036	-0.055	-0.047
PPM		-6.30574	-6.13159	-9.42979	-8.05273

Voltage (V)	Temperature (°C)	Test Results			
		5840MHz			
		1min	2min	5min	10min
120	-30	5840.008	5840.006	5840.007	5840.005
120	-20	5840.007	5840.005	5840.006	5840.004
120	-10	5840.000	5840.002	5839.998	5839.996
120	0	5840.000	5839.992	5839.994	5839.989
120	10	5839.998	5839.983	5839.994	5839.985
120	20	5839.995	5839.979	5839.989	5839.981
120	30	5839.988	5839.976	5839.985	5839.977
120	40	5839.979	5839.970	5839.977	5839.969
120	50	5839.976	5839.961	5839.971	5839.962
102	20	5839.972	5839.952	5839.965	5839.958
138	20	5839.968	5839.949	5839.963	5839.948
MHz		-0.032	-0.051	-0.037	-0.052
PPM		-5.47128	-8.65524	-6.31380	-8.83301

**Antenna 2**

Voltage (V)	Temperature (°C)	Test Results			
		5735MHz			
		1min	2min	5min	10min
120	-30	5735.008	5735.004	5735.006	5734.997
120	-20	5735.007	5735.005	5735.004	5734.998
120	-10	5735.002	5735.005	5735.001	5734.995
120	0	5734.993	5734.997	5735.001	5734.987
120	10	5734.993	5734.988	5734.991	5734.987
120	20	5734.985	5734.987	5734.985	5734.984
120	30	5734.975	5734.977	5734.985	5734.979
120	40	5734.967	5734.972	5734.984	5734.973
120	50	5734.962	5734.969	5734.975	5734.965
102	20	5734.960	5734.962	5734.968	5734.961
138	20	5734.950	5734.953	5734.966	5734.960
MHz		-0.050	-0.047	-0.034	-0.040
PPM		-8.65472	-8.26822	-6.00492	-6.94895



Voltage (V)	Temperature (°C)	Test Results			
		5790MHz			
		1min	2min	5min	10min
120	-30	5790.002	5790.007	5790.006	5790.005
120	-20	5790.003	5790.009	5790.009	5790.004
120	-10	5789.999	5790.000	5790.004	5789.999
120	0	5789.998	5789.993	5790.004	5789.998
120	10	5789.992	5789.983	5790.000	5789.992
120	20	5789.984	5789.979	5789.997	5789.989
120	30	5789.975	5789.977	5789.988	5789.980
120	40	5789.973	5789.975	5789.981	5789.979
120	50	5789.965	5789.965	5789.981	5789.974
102	20	5789.958	5789.962	5789.979	5789.972
138	20	5789.953	5789.960	5789.975	5789.970
MHz		-0.047	-0.040	-0.025	-0.030
PPM		-8.18728	-6.88439	-4.34262	-5.14345

Voltage (V)	Temperature (°C)	Test Results			
		5840MHz			
		1min	2min	5min	10min
120	-30	5840.008	5840.005	5840.008	5840.000
120	-20	5840.009	5840.004	5840.007	5840.000
120	-10	5840.008	5840.003	5840.002	5839.998
120	0	5840.008	5839.995	5839.997	5839.990
120	10	5840.005	5839.993	5839.996	5839.985
120	20	5840.004	5839.990	5839.994	5839.977
120	30	5839.995	5839.987	5839.988	5839.973
120	40	5839.988	5839.977	5839.983	5839.973
120	50	5839.979	5839.974	5839.975	5839.973
102	20	5839.970	5839.970	5839.969	5839.964
138	20	5839.961	5839.963	5839.964	5839.957
MHz		-0.039	-0.037	-0.036	-0.043
PPM		-6.71382	-6.33108	-6.11488	-7.43721

**Antenna 3**

Voltage (V)	Temperature (°C)	Test Results			
		5735MHz			
		1min	2min	5min	10min
120	-30	5735.007	5734.998	5734.996	5734.996
120	-20	5735.008	5735.000	5734.998	5734.997
120	-10	5735.006	5734.996	5734.989	5734.996
120	0	5735.006	5734.992	5734.986	5734.992
120	10	5735.000	5734.992	5734.978	5734.992
120	20	5734.991	5734.985	5734.970	5734.985
120	30	5734.985	5734.978	5734.965	5734.976
120	40	5734.984	5734.973	5734.956	5734.972
120	50	5734.982	5734.969	5734.954	5734.969
102	20	5734.981	5734.960	5734.949	5734.965
138	20	5734.981	5734.957	5734.940	5734.958
MHz		-0.019	-0.043	-0.060	-0.042
PPM		-3.36574	-7.42795	-10.52147	-7.24852

Voltage (V)	Temperature (°C)	Test Results			
		5790MHz			
		1min	2min	5min	10min
120	-30	5790.007	5789.998	5790.003	5790.004
120	-20	5790.006	5789.998	5790.001	5790.003
120	-10	5789.998	5789.998	5789.991	5789.997
120	0	5789.997	5789.992	5789.988	5789.989
120	10	5789.991	5789.988	5789.980	5789.986
120	20	5789.988	5789.986	5789.973	5789.984
120	30	5789.983	5789.980	5789.968	5789.975
120	40	5789.980	5789.971	5789.960	5789.967
120	50	5789.979	5789.961	5789.954	5789.960
102	20	5789.977	5789.954	5789.950	5789.957
138	20	5789.967	5789.948	5789.945	5789.947
MHz		-0.033	-0.052	-0.055	-0.053
PPM		-5.67938	-9.00459	-9.57526	-9.08626

Voltage (V)	Temperature (°C)	Test Results			
		5840MHz			
		1min	2min	5min	10min
120	-30	5840.005	5840.005	5840.008	5840.007
120	-20	5840.006	5840.004	5840.007	5840.006
120	-10	5840.004	5840.003	5840.004	5839.998
120	0	5839.996	5840.000	5839.994	5839.995
120	10	5839.991	5839.999	5839.987	5839.986
120	20	5839.990	5839.994	5839.983	5839.985
120	30	5839.981	5839.990	5839.979	5839.980
120	40	5839.974	5839.984	5839.976	5839.974
120	50	5839.974	5839.982	5839.968	5839.967
102	20	5839.968	5839.981	5839.965	5839.960
138	20	5839.964	5839.971	5839.961	5839.960
MHz		-0.036	-0.029	-0.039	-0.040
PPM		-6.22369	-4.89896	-6.70216	-6.85863

**Antenna 4**

Voltage (V)	Temperature (°C)	Test Results			
		5735MHz			
		1min	2min	5min	10min
120	-30	5735.004	5735.004	5734.997	5734.987
120	-20	5735.003	5735.003	5734.998	5734.989
120	-10	5734.995	5734.994	5734.995	5734.983
120	0	5734.993	5734.988	5734.993	5734.979
120	10	5734.983	5734.987	5734.984	5734.979
120	20	5734.979	5734.984	5734.976	5734.976
120	30	5734.977	5734.979	5734.974	5734.975
120	40	5734.968	5734.977	5734.973	5734.975
120	50	5734.963	5734.977	5734.970	5734.973
102	20	5734.956	5734.975	5734.968	5734.966
138	20	5734.950	5734.974	5734.966	5734.957
MHz		-0.050	-0.026	-0.034	-0.043
PPM		-8.80224	-4.54678	-6.00068	-7.48464





Voltage (V)	Temperature (°C)	Test Results			
		5790MHz			
		1min	2min	5min	10min
120	-30	5790.004	5790.005	5790.006	5790.003
120	-20	5790.005	5790.006	5790.005	5790.002
120	-10	5790.004	5790.003	5789.997	5789.992
120	0	5790.001	5789.994	5789.988	5789.989
120	10	5790.000	5789.994	5789.988	5789.989
120	20	5789.991	5789.989	5789.979	5789.982
120	30	5789.983	5789.982	5789.976	5789.981
120	40	5789.977	5789.977	5789.973	5789.981
120	50	5789.977	5789.968	5789.965	5789.978
102	20	5789.970	5789.960	5789.964	5789.974
138	20	5789.970	5789.952	5789.963	5789.967
MHz		-0.030	-0.048	-0.037	-0.033
PPM		-5.25063	-8.37010	-6.44422	-5.64912

Voltage (V)	Temperature (°C)	Test Results			
		5840MHz			
		1min	2min	5min	10min
120	-30	5840.007	5840.007	5840.002	5840.008
120	-20	5840.008	5840.006	5840.001	5840.009
120	-10	5840.002	5839.997	5839.999	5840.003
120	0	5840.001	5839.988	5839.993	5839.994
120	10	5839.993	5839.987	5839.991	5839.986
120	20	5839.990	5839.985	5839.987	5839.985
120	30	5839.986	5839.984	5839.985	5839.980
120	40	5839.983	5839.977	5839.976	5839.975
120	50	5839.976	5839.973	5839.970	5839.972
102	20	5839.973	5839.973	5839.960	5839.966
138	20	5839.973	5839.963	5839.960	5839.956
MHz		-0.027	-0.037	-0.040	-0.044
PPM		-4.64219	-6.27712	-6.92594	-7.45700

### 5.4. Power Spectral Density

#### Ambient condition

Temperature	Relative humidity	Pressure
23°C ~25°C	45%~50%	101.5kPa

#### Method of Measurement

The EUT was connected to the spectrum analyzer through an external attenuator (20dB) and a known loss cable.

Set RBW = 510 kHz, VBW = 1.5MHz for the band 5.725-5.85 GHz

The conducted PSD is measured at each antenna port. The measured results at the various antenna ports are then summed mathematically.

#### Test setup

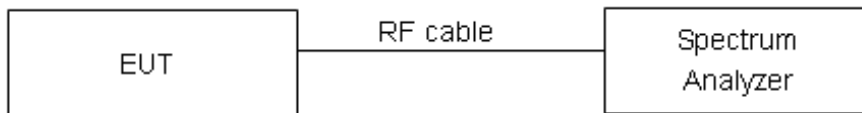

#### Limits

Rule FCC Part 15.407(a)(3)

For the band 5.725-5.85 GHz, the maximum power spectral density shall not exceed 30 dBm in any 500-kHz band. If transmitting antennas of directional gain greater than 6 dBi are used, both the maximum conducted output power and the maximum power spectral density shall be reduced by the amount in dB that the directional gain of the antenna exceeds 6 dBi.

Frequency Bands/MHz	Limits
5725-5850	30dBm/500kHz

#### Measurement Uncertainty

The assessed measurement uncertainty to ensure 95% confidence level for the normal distribution is with the coverage factor  $k = 2$ ,  $U = 0.75\text{dB}$ .

**Test Results:****TM1**

Antenna	Frequency (MHz)	Power Spectral Density (dBm/500kHz)	Limit (dBm/500kHz)	Conclusion
Antenna 1	5735	10.510	30	PASS
	5790	9.568	30	PASS
	5840	10.661	30	PASS
Antenna 2	5735	10.371	30	PASS
	5790	9.943	30	PASS
	5840	10.568	30	PASS
Antenna 3	5735	10.843	30	PASS
	5790	12.205	30	PASS
	5840	10.952	30	PASS
Antenna 4	5735	11.124	30	PASS
	5790	10.708	30	PASS
	5840	11.357	30	PASS

Frequency (MHz)	Power Spectral Density (dBm/500kHz)										Limit (dBm/500kHz)	Conclusion
	Antenna 1		Antenna 2		Antenna 3		Antenna 4		MIMO			
	(dBm)	(mW)	(dBm)	(mW)	(dBm)	(mW)	(dBm)	(mW)	(mW)	(dBm)		
5735	10.510	11.246	10.371	10.892	10.843	12.142	11.124	12.954	47.234	16.743	28	PASS
5790	9.568	9.053	9.943	9.870	12.205	16.615	10.708	11.771	47.309	16.749	28	PASS
5840	10.661	11.644	10.568	11.397	10.952	12.451	11.357	13.668	49.160	16.916	28	PASS

Note:1.For MIMO mode,according to KDB 662911 D01 Multiple Transmitter Output v02r01 2)a),the power spectral density= $10\log(10^{(\text{PSD antenna1 in dBm}/10)}+10^{(\text{PSD antenna2 in dBm}/10)}+10^{(\text{PSD antenna3 in dBm}/10)}+10^{(\text{PSD antenna4 in dBm}/10)})$

2. For MIMO mode,the manufacturer declared the transmitter output signals are SFBC modes combine with CDD modes.The signals are antenna 1,2 correlated and 3,4 correlated. And 1,2 and 3,4 are completely uncorrelated.According to KDB 662911 D01 Multiple Transmitter Output v02r01 2)a)(i):If any transmit signals are correlated with each other,Directional gain = GANT + 10 log(NANT) dB=5+10log(2)=8dB>6dB.So the power limit shall be reduced to 30-(8-6)=28dBm.



TM2

Antenna	Frequency (MHz)	Power Spectral Density (dBm/500kHz)	Limit (dBm/500kHz)	Conclusion
Antenna 1	5735	10.676	30	PASS
	5790	10.826	30	PASS
	5840	11.191	30	PASS
Antenna 2	5735	9.876	30	PASS
	5790	10.299	30	PASS
	5840	11.195	30	PASS
Antenna 3	5735	10.571	30	PASS
	5790	10.897	30	PASS
	5840	11.295	30	PASS
Antenna 4	5735	11.530	30	PASS
	5790	10.770	30	PASS
	5840	11.422	30	PASS

Frequency (MHz)	Power Spectral Density (dBm/500kHz)										Limit (dBm/500kHz)	Conclusion
	Antenna 1		Antenna 2		Antenna 3		Antenna 4		MIMO			
	(dBm)	(mW)	(dBm)	(mW)	(dBm)	(mW)	(dBm)	(mW)	(mW)	(dBm)		
5735	10.676	11.684	9.876	9.719	10.571	11.405	11.530	14.223	47.031	16.724	28	PASS
5790	10.826	12.095	10.299	10.713	10.897	12.294	10.770	11.940	47.042	16.725	28	PASS
5840	11.191	13.155	11.195	13.167	11.295	13.474	11.422	13.874	53.670	17.297	28	PASS

Note: 1. For MIMO mode, according to KDB 662911 D01 Multiple Transmitter Output v02r01 2)a), the power spectral density =  $10\log(10^{(PSD_{antenna1} \text{ in dBm}/10)} + 10^{(PSD_{antenna2} \text{ in dBm}/10)} + 10^{(PSD_{antenna3} \text{ in dBm}/10)} + 10^{(PSD_{antenna4} \text{ in dBm}/10)})$

2. For MIMO mode, the manufacturer declared the transmitter output signals are SFBC modes combine with CDD modes. The signals are antenna 1,2 correlated and 3,4 correlated. And 1,2 and 3,4 are completely uncorrelated. According to KDB 662911 D01 Multiple Transmitter Output v02r01 2)a)(i): If any transmit signals are correlated with each other, Directional gain =  $GANT + 10\log(NANT)$  dB =  $5 + 10\log(2) = 8\text{dB} > 6\text{dB}$ . So the power limit shall be reduced to  $30 - (8 - 6) = 28\text{dBm}$ .

TM3

Antenna	Frequency (MHz)	Power Spectral Density (dBm/500kHz)	Limit (dBm/500kHz)	Conclusion
Antenna 1	5735	8.811	30	PASS
	5790	8.365	30	PASS
	5840	8.037	30	PASS
Antenna 2	5735	8.014	30	PASS
	5790	8.284	30	PASS
	5840	8.212	30	PASS
Antenna 3	5735	9.307	30	PASS
	5790	10.008	30	PASS
	5840	9.081	30	PASS
Antenna 4	5735	9.717	30	PASS
	5790	8.823	30	PASS
	5840	9.432	30	PASS

Frequency (MHz)	Power Spectral Density (dBm/500kHz)										Limit (dBm/500kHz)	Conclusion
	Antenna 1		Antenna 2		Antenna 3		Antenna 4		MIMO			
	(dBm)	(mW)	(dBm)	(mW)	(dBm)	(mW)	(dBm)	(mW)	(mW)	(dBm)		
5735	8.811	7.605	8.014	6.330	9.307	8.525	9.717	9.369	31.829	15.028	28	PASS
5790	8.365	6.863	8.284	6.736	10.008	10.018	8.823	7.626	31.243	14.948	28	PASS
5840	8.037	6.364	8.212	6.625	9.081	8.093	9.432	8.774	29.856	14.750	28	PASS

Note:1.For MIMO mode,according to KDB 662911 D01 Multiple Transmitter Output v02r01 2)a),the power spectral density= $10\log(10^{(PSD\ antenna1\ in\ dBm/10)}+10^{(PSD\ antenna2\ in\ dBm/10)}+10^{(PSD\ antenna3\ in\ dBm/10)}+10^{(PSD\ antenna4\ in\ dBm/10)})$

2. For MIMO mode,the manufacturer declared the transmitter output signals are SFBC modes combine with CDD modes.The signals are antenna 1,2 correlated and 3,4 correlated. And 1,2 and 3,4 are completely uncorrelated.According to KDB 662911 D01 Multiple Transmitter Output v02r01 2)a)(i):If any transmit signals are correlated with each other,Directional gain = GANT + 10 log(NANT) dBi=5+10log(2)=8dBi>6dBi.So the power limit shall be reduced to 30-(8-6)=28dBm.



TM1

Antenna 1, Frequency (MHz): 5735

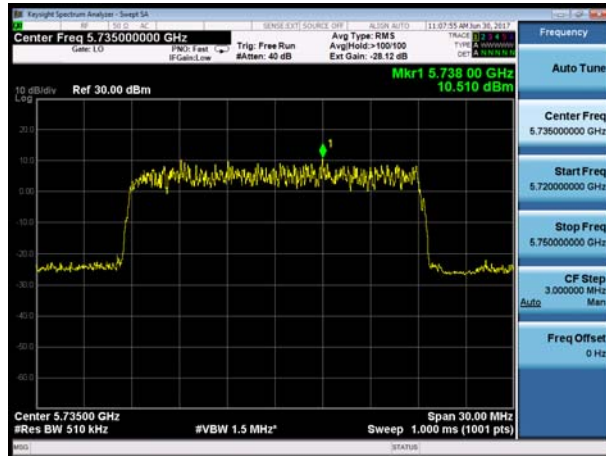

Antenna 2, Frequency (MHz): 5735

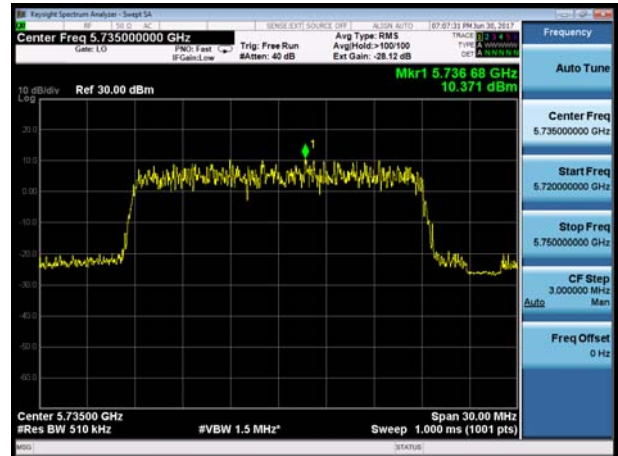

Antenna 1, Frequency (MHz): 5790

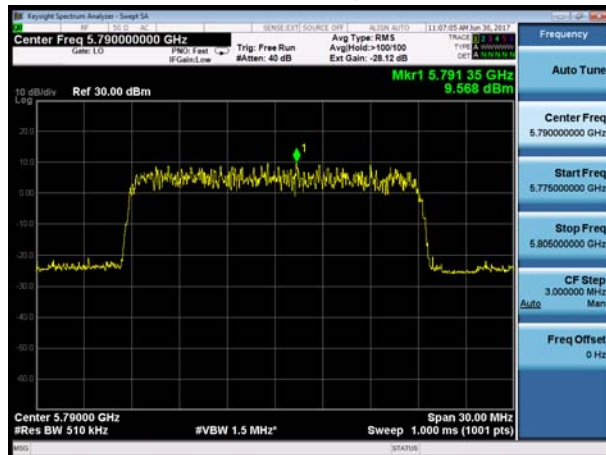

Antenna 2, Frequency (MHz): 5790

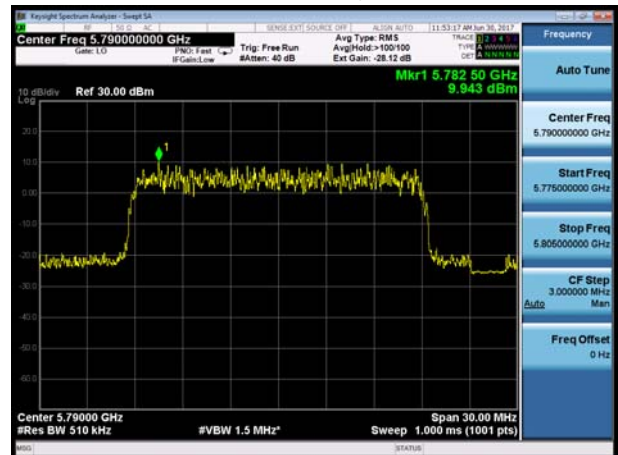

Antenna 1, Frequency (MHz): 5840

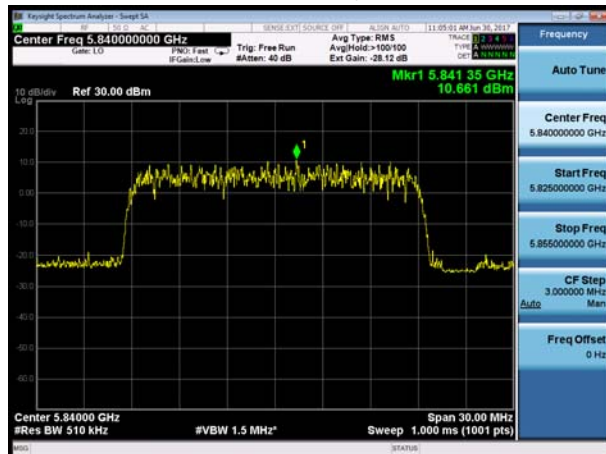

Antenna 2, Frequency (MHz): 5840





Antenna 3, Frequency (MHz): 5735

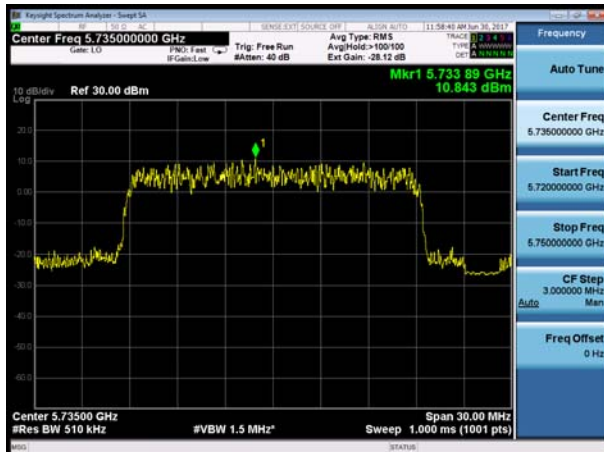

Antenna 4, Frequency (MHz): 5735



Antenna 3, Frequency (MHz): 5790

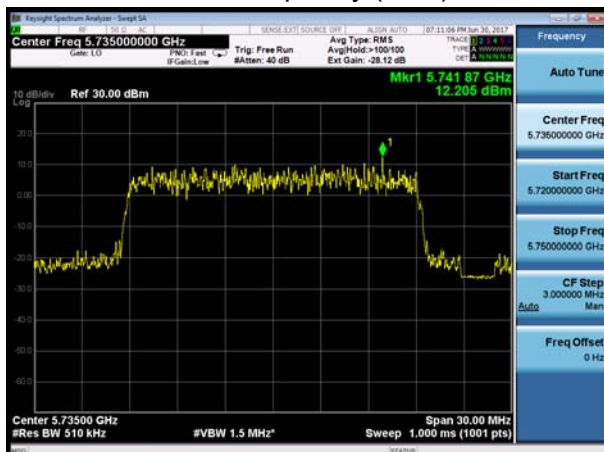

Antenna 4, Frequency (MHz): 5790

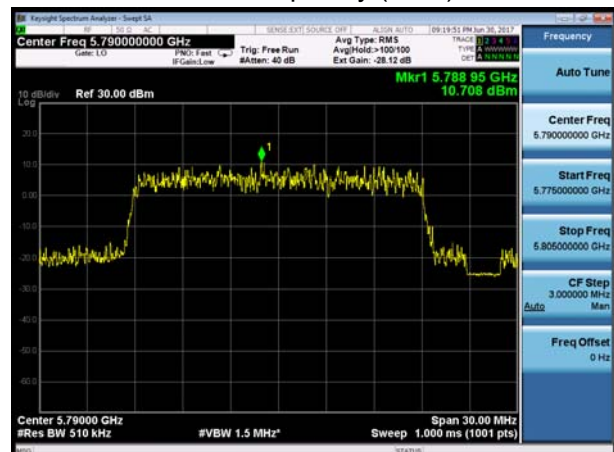

Antenna 3, Frequency (MHz): 5840

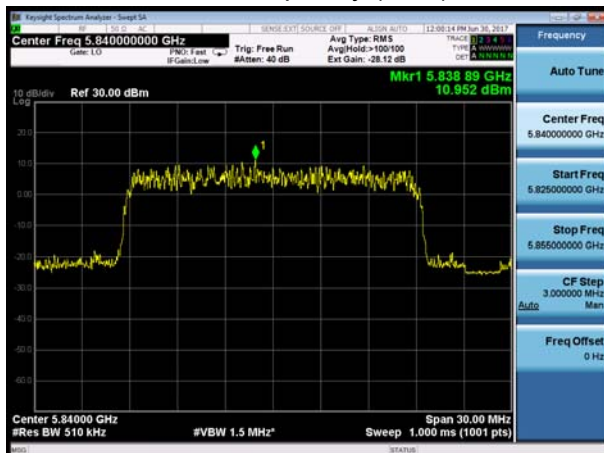

Antenna 4, Frequency (MHz): 5840





TM2

Antenna 1, Frequency (MHz): 5735

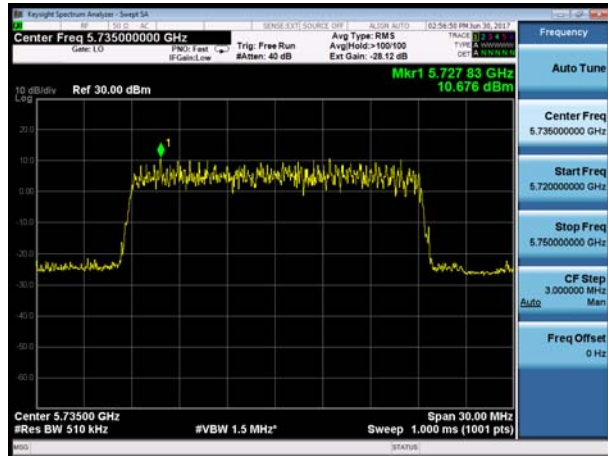

Antenna 2, Frequency (MHz): 5735



Antenna 1, Frequency (MHz): 5790

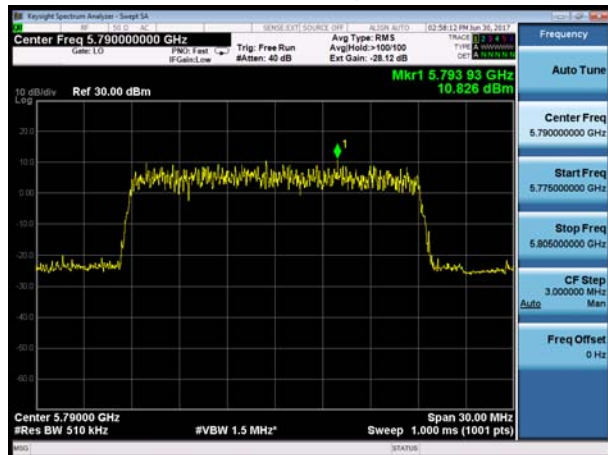

Antenna 2, Frequency (MHz): 5790

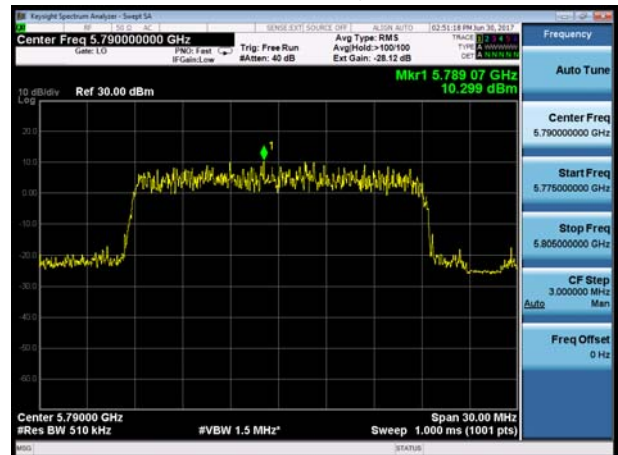

Antenna 1, Frequency (MHz): 5840



Antenna 2, Frequency (MHz): 5840







Antenna 3, Frequency (MHz): 5735

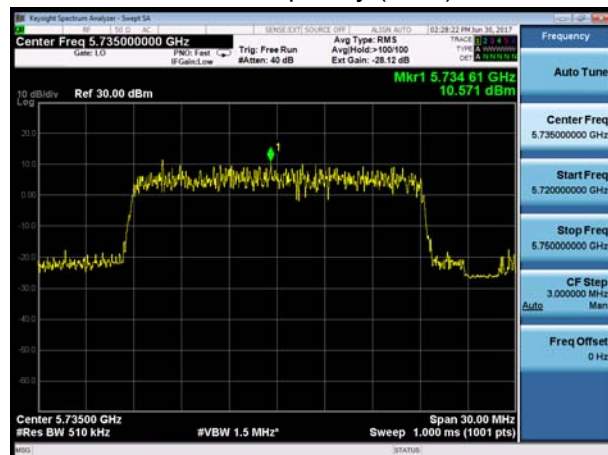

Antenna 4, Frequency (MHz): 5735



Antenna 3, Frequency (MHz): 5790

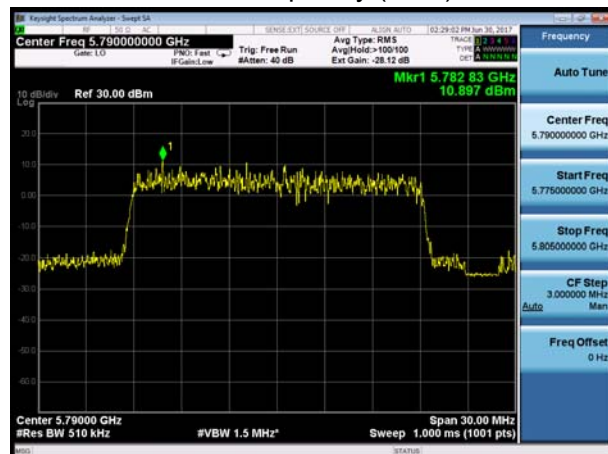

Antenna 4, Frequency (MHz): 5790



Antenna 3, Frequency (MHz): 5840

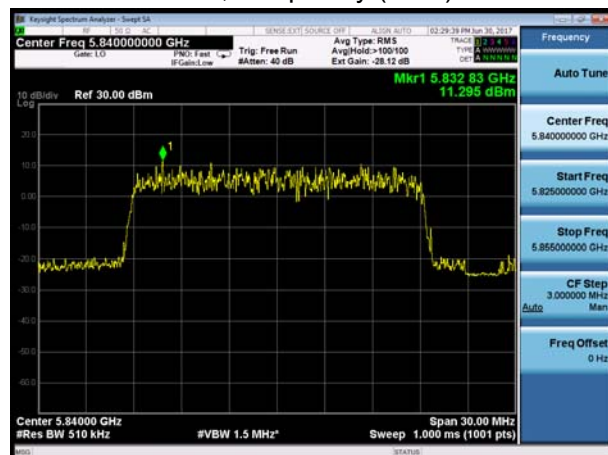

Antenna 4, Frequency (MHz): 5840





TM3

Antenna 1, Frequency (MHz): 5735



Antenna 2, Frequency (MHz): 5735



Antenna 1, Frequency (MHz): 5790



Antenna 2, Frequency (MHz): 5790



Antenna 1, Frequency (MHz): 5840

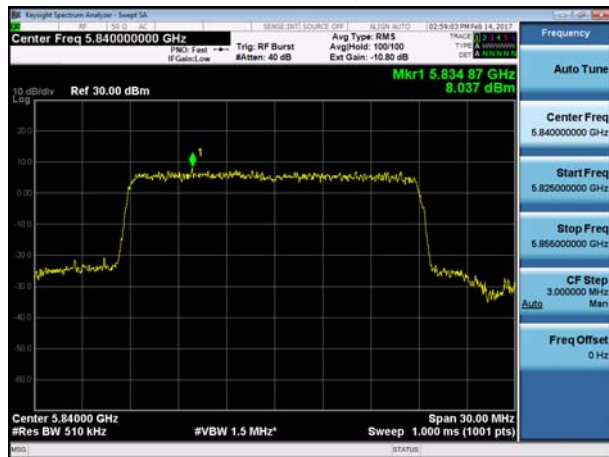

Antenna 2, Frequency (MHz): 5840





Antenna 3, Frequency (MHz): 5735

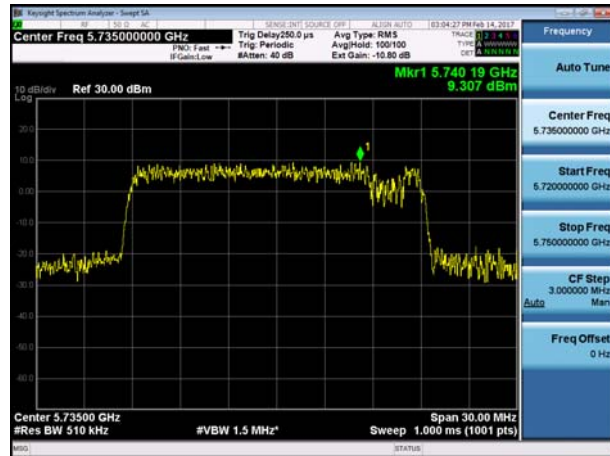

Antenna 4, Frequency (MHz): 5735



Antenna 3, Frequency (MHz): 5790

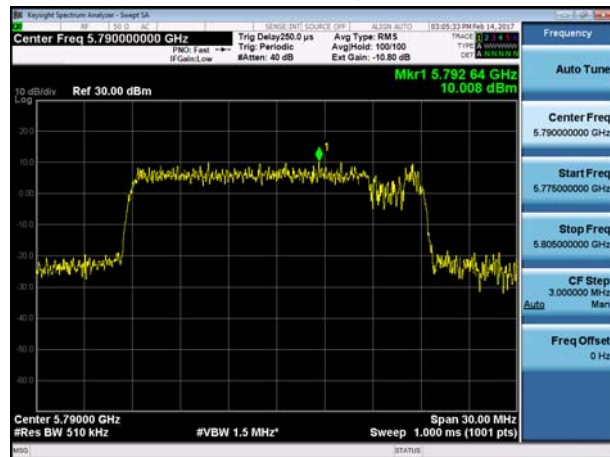

Antenna 4, Frequency (MHz): 5790



Antenna 3, Frequency (MHz): 5840

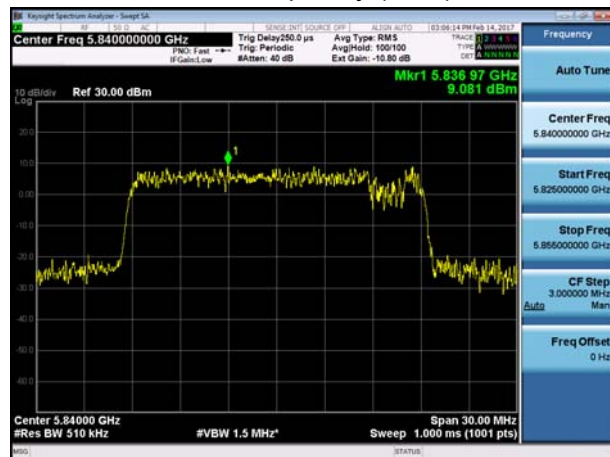

Antenna 4, Frequency (MHz): 5840



## 5.5. Unwanted Emission

### Ambient condition

Temperature	Relative humidity	Pressure
23°C ~25°C	45%~50%	101.5kPa

### Radiated Measurement

The test set-up was made in accordance to the general provisions of ANSI C63.10-2013. The Equipment Under Test (EUT) was set up on a non-conductive table in the semi-anechoic chamber. The test was performed at the distance of 3 m between the EUT and the receiving antenna. The radiated emissions measurements were made in a typical installation configuration. Sweep the whole frequency band range from 9kHz to the 10th harmonic of the carrier, and the emissions less than 20 dB below the permissible value are reported.

During the test, the height of receive antenna shall be moved from 1 to 4 meters, and the antenna shall be performed under horizontal and vertical polarization. The turntable shall be rotated from 0 to 360 degrees for detecting the maximum of radiated spurious signal level. The measurements shall be repeated with orthogonal polarization of the test antenna. The data of cable loss and antenna factor has been calibrated in full testing frequency range before the testing.

Set the spectrum analyzer in the following:

Below 1GHz (detector: Peak and Quasi-Peak)

RBW=100kHz / VBW=300kHz / Sweep=AUTO

Above 1GHz (detector: Peak):

(a) PEAK: RBW=1MHz VBW=3MHz/ Sweep=AUTO

(b) AVERAGE: RBW=1MHz / VBW=3MHz / Sweep=AUTO

The radiated emission was measured in the following position: EUT stand-up position (Z axis), lie-down position (X, Y axis). The worst emission was found in stand-up position (Z axis) and the worst case was recorded.

In order to find the worst case condition, Pre-tests are needed at the presence of different data rate. TM3 data rate below means worst-case rate of each test item.

The test is in transmitting mode.

9KHz~~~30MHz

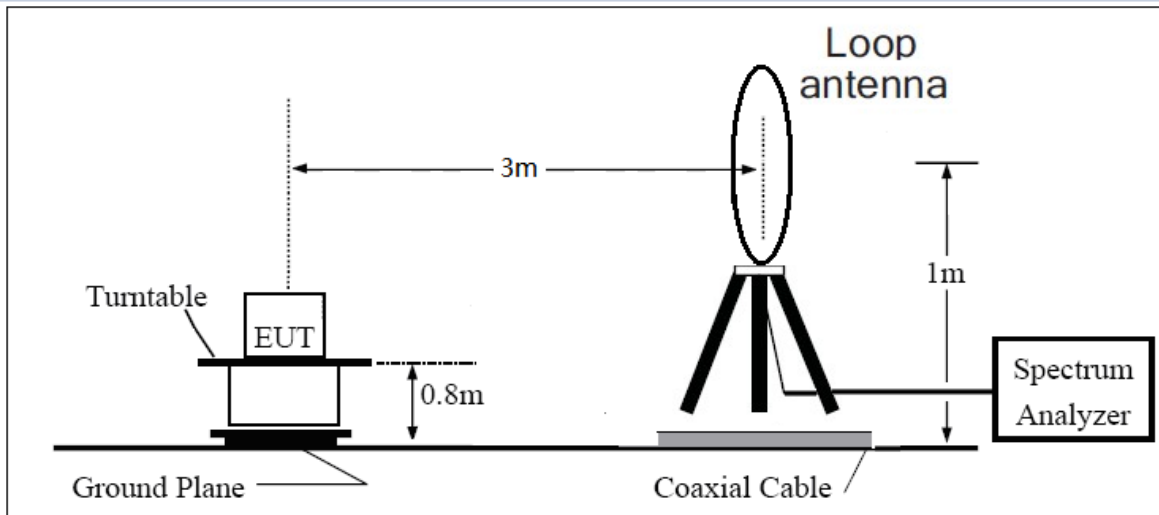

30MHz~~~ 1GHz

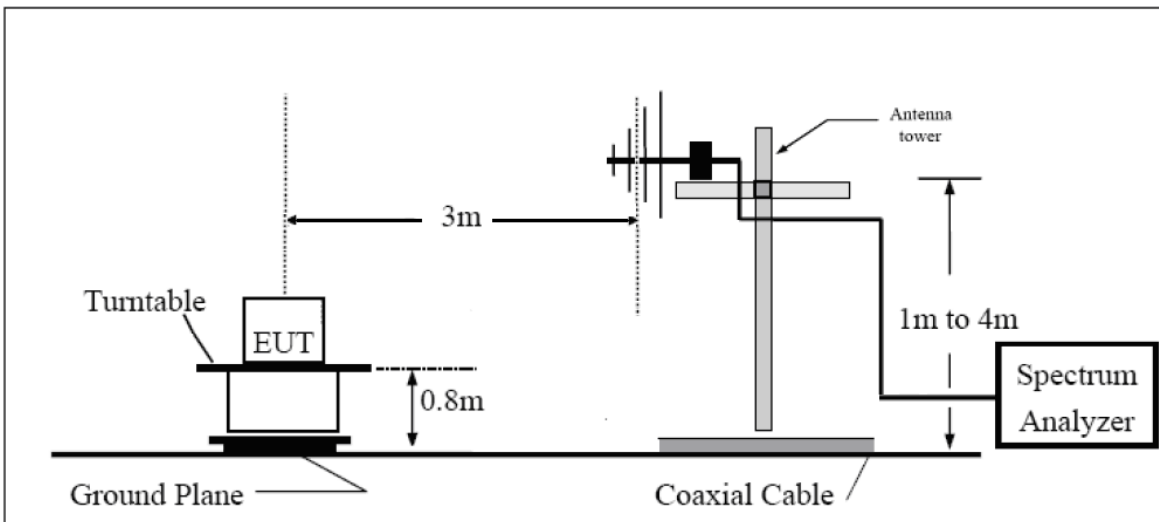

Above 1GHz

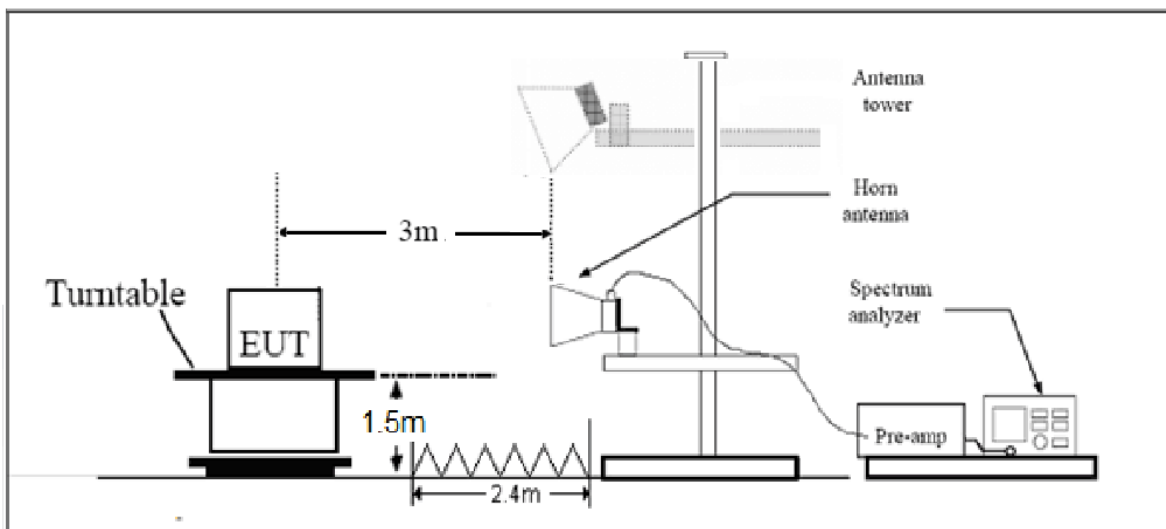

Note: Area side:2.4mX3.6m

**Limits**

FCC §407 (b) Undesirable emission limits. Except as shown in paragraph (b)(7) of this section, the maximum emissions outside of the frequency bands of operation shall be attenuated in accordance with the following limits:

For transmitters operating in the 5725-5850 MHz band: All emissions shall be limited to a level of -27 dBm/MHz at 75 MHz or more above or below the band edge increasing linearly to 10 dBm/MHz at 25 MHz above or below the band edge, and from 25 MHz above or below the band edge increasing linearly to a level of 15.6 dBm/MHz at 5 MHz above or below the band edge, and from 5 MHz above or below the band edge increasing linearly to a level of 27 dBm/MHz at the band edge.

Note: the following formula is used to convert the EIRP to field strength

§1、  $E[\text{dB}\mu\text{V}/\text{m}] = \text{EIRP}[\text{dBm}] - 20 \log(d[\text{meters}]) + 104.77$ , where E = field strength and

d = distance at which field strength limit is specified in the rules;

§2、  $E[\text{dB}\mu\text{V}/\text{m}] = \text{EIRP}[\text{dBm}] + 95.2$ , for d = 3 meters

(1) Unwanted spurious emissions fallen in restricted bands per FCC Part15.205 shall comply with the general field strength limits set forth in § 15.209 as below table.

Frequency of emission (MHz)	Field strength(uV/m)	Field strength(dBuV/m)
0.009–0.490	2400/F(kHz)	/
0.490–1.705	24000/F(kHz)	/
1.705–30.0	30	/
30-88	100	40
88-216	150	43.5
216-960	200	46
Above960	500	54

MHz	MHz	MHz	GHz
0.090 - 0.110	16.42 - 16.423	399.9 - 410	4.5 - 5.15
0.495 - 0.505	16.69475 - 16.69525	608 - 614	5.35 - 5.46
2.1735 - 2.1905	16.80425 - 16.80475	960 - 1240	7.25 - 7.75
4.125 - 4.128	25.5 - 25.67	1300 - 1427	8.025 - 8.5
4.17725 - 4.17775	37.5 - 38.25	1435 - 1626.5	9.0 - 9.2
4.20725 - 4.20775	73 - 74.6	1645.5 - 1646.5	9.3 - 9.5
6.215 - 6.218	74.8 - 75.2	1660 - 1710	10.6 - 12.7
6.26775 - 6.26825	108 - 121.94	1718.8 - 1722.2	13.25 - 13.4
6.31175 - 6.31225	123 - 138	2200 - 2300	14.47 - 14.5
8.291 - 8.294	149.9 - 150.05	2310 - 2390	15.35 - 16.2
8.362 - 8.366	156.52475 - 156.52525	2483.5 - 2500	17.7 - 21.4
8.37625 - 8.38675	156.7 - 156.9	2690 - 2900	22.01 - 23.12
8.41425 - 8.41475	162.0125 - 167.17	3260 - 3267	23.6 - 24.0
12.29 - 12.293	167.72 - 173.2	3332 - 3339	31.2 - 31.8
12.51975 - 12.52025	240 - 285	3345.8 - 3358	36.43 - 36.5
12.57675 - 12.57725	322 - 335.4	3600 - 4400	( <sup>2</sup> )
13.36 - 13.41			

**Measurement Uncertainty**

The assessed measurement uncertainty to ensure 95% confidence level for the normal distribution is with the coverage factor  $k = 1.96$ .

Frequency	Uncertainty
9KHz-30MHz	3.55 dB
30MHz-200MHz	4.19 dB
200MHz-1GHz	3.63 dB
1GHz-26.5G	3.68 dB
26.5G-40GHz	4.76dB



**Radiated Test Results:**

**TM3**

**The signal beyond the limit is carrier.**

**MIMO Antenna 1&2**

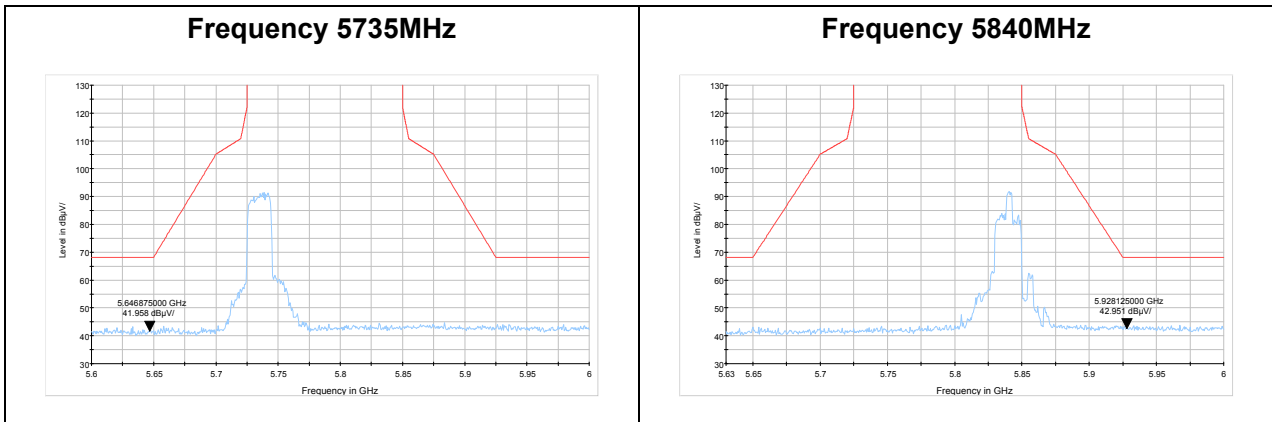

**MIMO antenna 3&4**

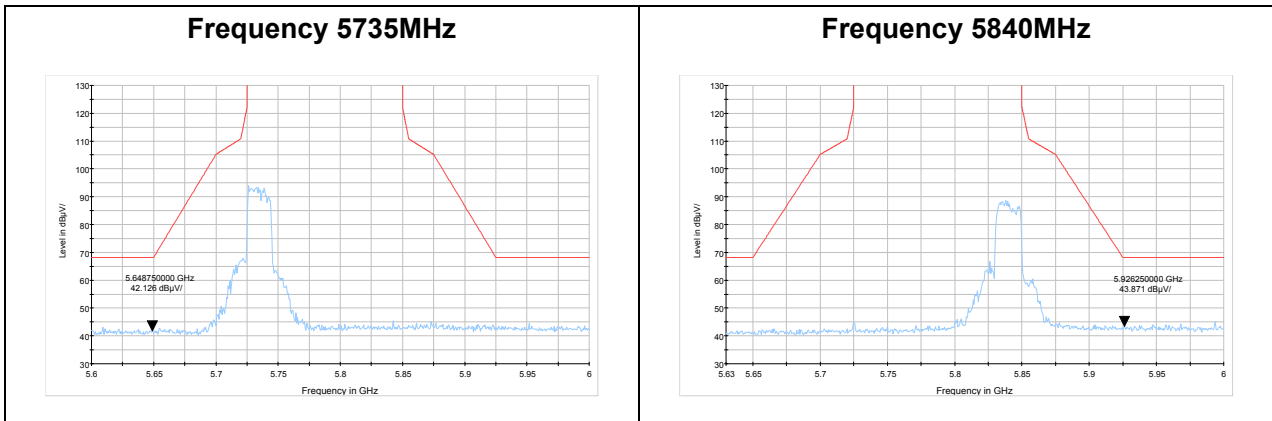





### Result of RE

#### Test result

Sweep the whole frequency band through the range from 9kHz to the 10th harmonic of the carrier, and 9kHz-30MHz, the emissions more than 20 dB below the permissible value are not reported.

TM3

MIMO Antenna 1&2

5735MHz

RE 30M-1GHz QP

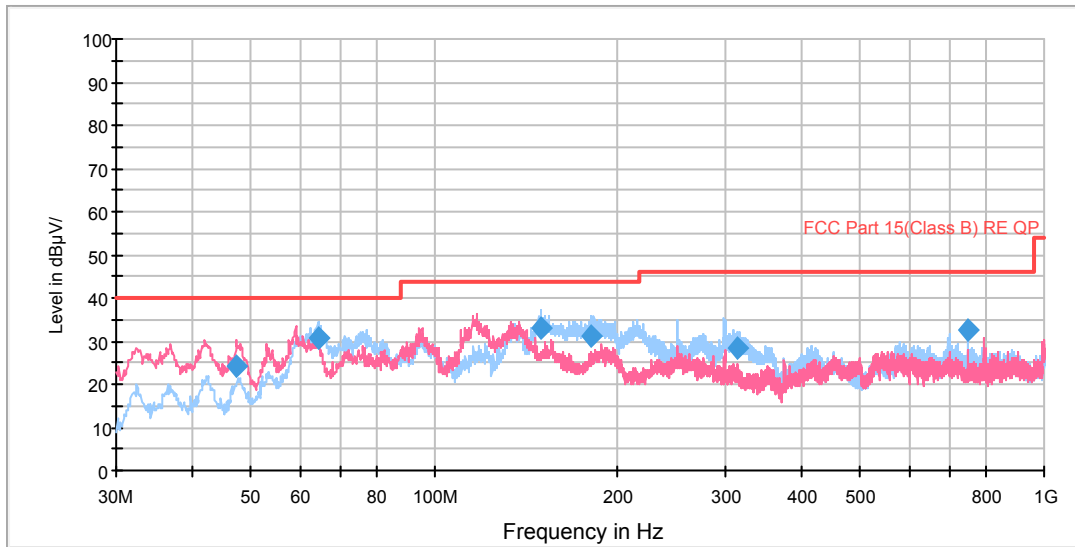

Radiates Emission from 30MHz to 1GHz

Frequency (MHz)	Quasi-Peak (dBuV/m)	Height (cm)	Polarization	Azimuth (deg)	Reading value (dBuV/m)	Correct Factor (dB)	Margin (dB)	Limit (dBuV/m)
47.335544	24.0	121.0	V	100.0	44.3	-20.3	16.0	40.0
64.472966	30.9	130.0	H	22.0	54.6	-23.7	9.1	40.0
149.440169	33.1	130.0	H	146.0	62.3	-29.2	10.4	43.5
180.699125	31.2	130.0	H	341.0	59.3	-28.1	12.3	43.5
313.343750	28.2	101.0	H	291.0	51.3	-23.1	17.8	46.0
749.987500	32.8	101.0	H	136.0	48.2	-15.4	13.2	46.0

- Remark: 1. Quasi-Peak = Reading value + Correction factor
- 2. Correction Factor = Antenna factor+ Insertion loss(cable loss+amplifier gain)
- 3. Margin = Limit – Quasi-Peak

RE 1G-3GHz PK+AV

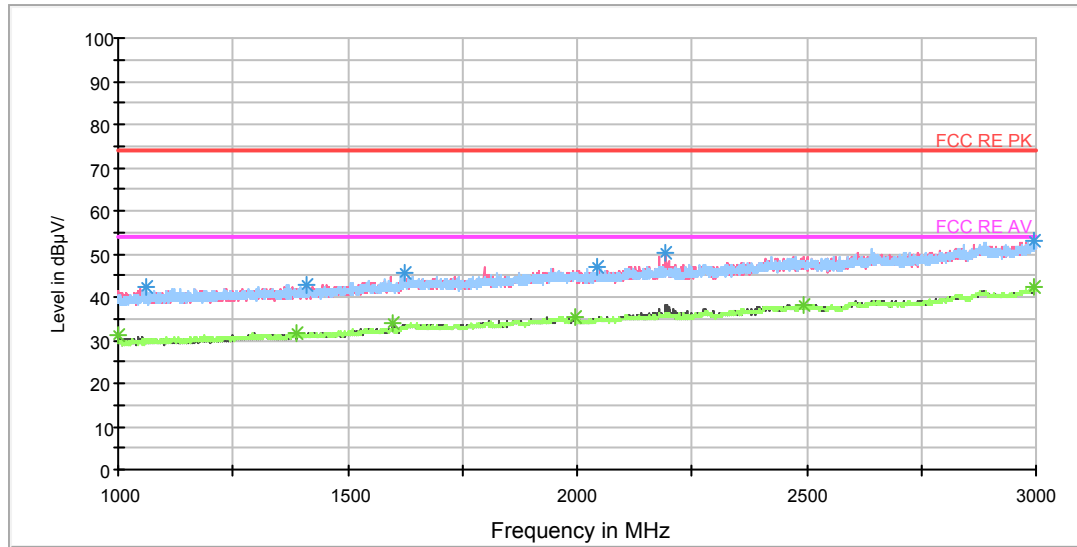

Radiates Emission from 1GHz to 3GHz

Frequency (MHz)	Peak (dBuV/m)	Height (cm)	Polarization	Azimuth (deg)	Reading value (dBuV/m)	Correct Factor (dB)	Margin (dB)	Limit (dBuV/m)
1062.250000	42.2	104.0	H	53.0	51.1	-8.9	31.8	74
1410.250000	42.9	104.0	V	0.0	50.0	-7.1	31.1	74
1623.000000	45.7	104.0	H	17.0	50.5	-4.8	28.3	74
2043.500000	46.9	104.0	H	17.0	50.1	-3.2	27.1	74
2193.000000	50.1	104.0	V	181.0	52.2	-2.1	23.9	74
2995.000000	53.2	104.0	V	212.0	50.9	2.3	20.8	74

Remark: 1. Correction Factor = Antenna factor+ Insertion loss (cable loss + amplifier gain)

Frequency (MHz)	Average (dBuV/m)	Height (cm)	Polarization	Azimuth (deg)	Reading value (dBuV/m)	Correct Factor (dB)	Margin (dB)	Limit (dBuV/m)
1000.250000	31.3	104.0	V	190.0	40.5	-9.2	22.7	54
1389.000000	31.8	104.0	H	53.0	38.8	-7.0	22.2	54
1599.750000	34.1	104.0	V	283.0	40.5	-6.4	19.9	54
1997.750000	35.6	104.0	V	212.0	38.9	-3.3	18.4	54
2492.000000	38.3	104.0	H	0.0	38.0	0.3	15.7	54
2994.000000	42.4	104.0	H	79.0	40.1	2.3	11.6	54

Remark: 1. Correction Factor = Antenna factor+ Insertion loss (cable loss + amplifier gain)

RE 3-18GHz PK+AV

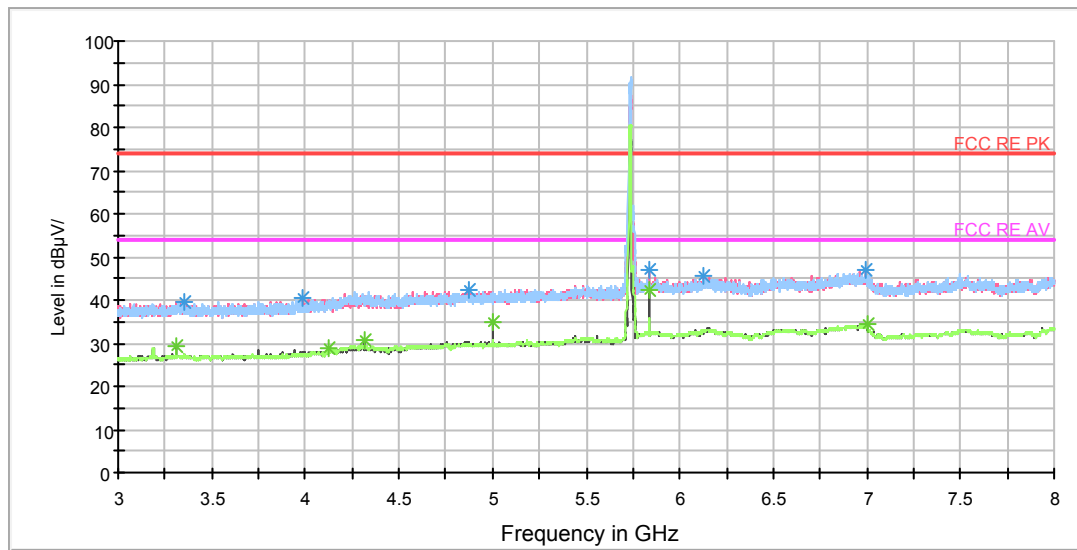

Note: The signal beyond the limit is carrier.  
Radiates Emission from 3GHz to 8GHz

Frequency (MHz)	Peak (dBuV/m)	Height (cm)	Polarization	Azimuth (deg)	Reading value (dBuV/m)	Correct Factor (dB)	Margin (dB)	Limit (dBuV/m)
3353.750000	39.6	105.0	H	83.0	41.9	-2.3	34.4	74
3981.875000	40.6	105.0	V	0.0	41.6	-1.0	33.4	74
4873.750000	42.2	105.0	H	8.0	40.4	1.8	31.8	74
5840.000000	47.1	105.0	V	340.0	42.6	4.5	26.9	74
6123.750000	45.7	105.0	V	20.0	40.3	5.4	28.3	74
6996.250000	46.8	105.0	V	266.0	40.3	6.5	27.2	74

Remark: 1. Correction Factor = Antenna factor+ Insertion loss (cable loss + amplifier gain)

Frequency (MHz)	Average (dBuV/m)	Height (cm)	Polarization	Azimuth (deg)	Reading value (dBuV/m)	Correct Factor (dB)	Margin (dB)	Limit (dBuV/m)
3312.500000	29.4	105.0	V	0.0	31.5	-2.1	24.6	54
4125.000000	28.9	105.0	V	131.0	29.3	-0.4	25.1	54
4312.500000	30.7	105.0	V	0.0	30.1	0.6	23.3	54
5000.000000	35.0	105.0	V	340.0	33.4	1.6	19.0	54
5840.000000	42.4	105.0	V	340.0	37.9	4.5	11.6	54
6999.375000	34.3	105.0	H	133.0	27.8	6.5	19.7	54

Remark: 1. Correction Factor = Antenna factor+ Insertion loss (cable loss + amplifier gain)

RE 3-18GHz PK+AV(YIPU)

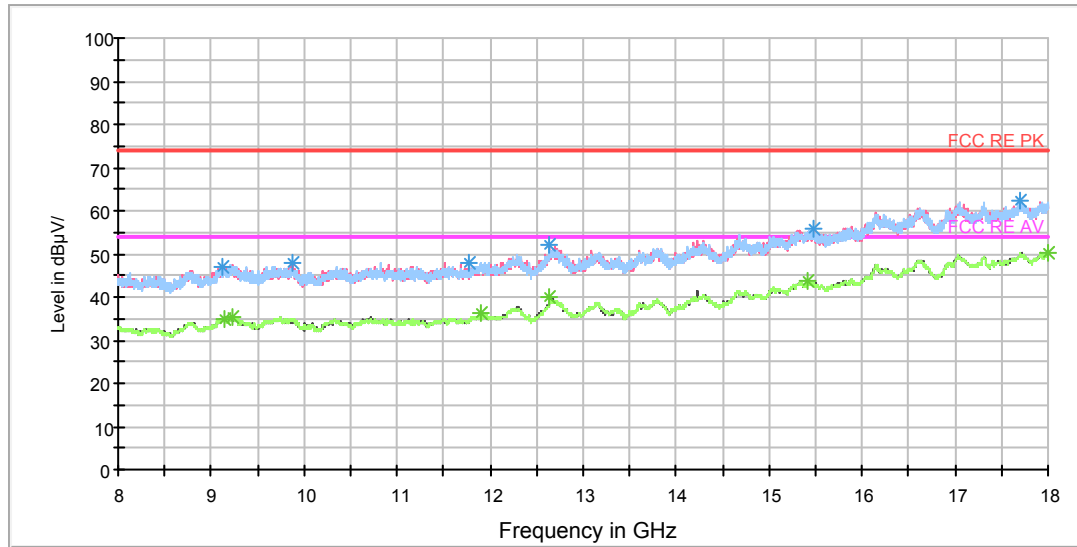

Radiates Emission from 8GHz to 18GHz

Frequency (MHz)	Peak (dBuV/m)	Height (cm)	Polarization	Azimuth (deg)	Reading value (dBuV/m)	Correct Factor (dB)	Margin (dB)	Limit (dBuV/m)
9117.500000	46.9	105.0	H	0.0	36.9	10.0	27.1	74
9878.750000	47.7	106.0	V	161.0	37.4	10.3	26.3	74
11781.250000	48.1	105.0	H	0.0	36.6	11.5	25.9	74
12642.500000	52.1	205.0	V	226.0	37.6	14.5	21.9	74
15468.750000	55.9	205.0	V	281.0	36.2	19.7	18.1	74
17705.000000	62.1	205.0	H	0.0	37.4	24.7	11.9	74

Remark: 1. Correction Factor = Antenna factor+ Insertion loss (cable loss + amplifier gain)

Frequency (MHz)	Average (dBuV/m)	Height (cm)	Polarization	Azimuth (deg)	Reading value (dBuV/m)	Correct Factor (dB)	Margin (dB)	Limit (dBuV/m)
9151.250000	35.1	205.0	H	0.0	24.9	10.2	18.9	54
9232.500000	35.5	106.0	V	0.0	25.6	9.9	18.5	54
11898.750000	36.3	205.0	H	0.0	24.0	12.3	17.7	54
12638.750000	39.8	106.0	V	0.0	25.4	14.4	14.2	54
15417.500000	43.7	105.0	H	7.0	24.4	19.3	10.3	54
17997.500000	50.4	106.0	V	269.0	25.0	25.4	3.6	54

Remark: 1. Correction Factor = Antenna factor+ Insertion loss (cable loss + amplifier gain)

RE 18-26.5GHz PK+AV

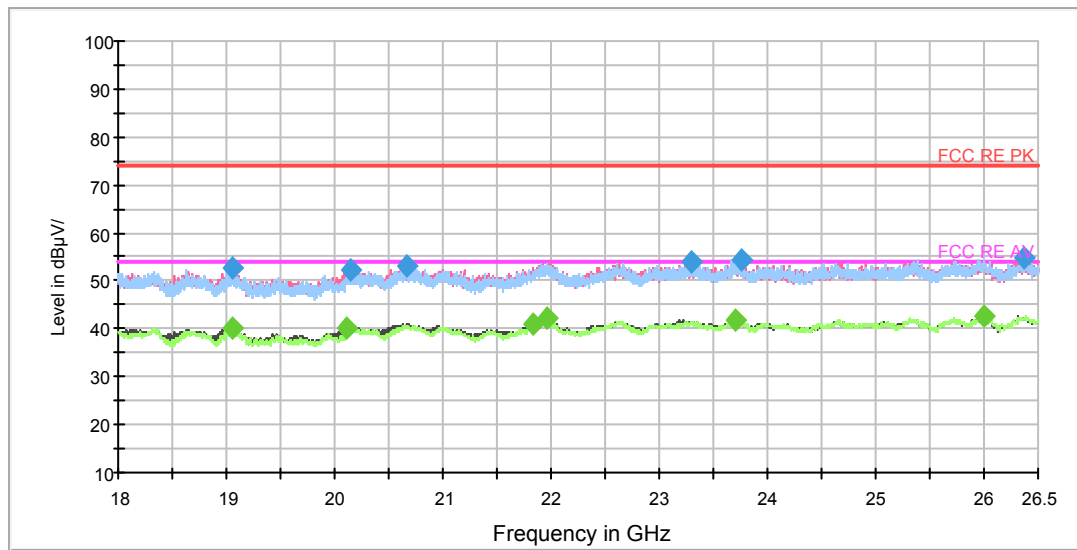

Radiates Emission from 18GHz to 26.5GHz

Frequency (MHz)	Peak (dBuV/m)	Polarization	Azimuth (deg)	Reading value (dBuV/m)	Correct Factor (dB)	Margin (dB)	Limit (dBuV/m)
19059.312500	52.9	V	157.0	58.1	-5.2	21.1	74.0
20150.500000	52.4	V	157.0	58.2	-5.8	21.6	74.0
20662.625000	53.0	V	183.0	59.6	-6.6	21.0	74.0
23289.125000	53.8	V	0.0	59.8	-6.0	20.2	74.0
23751.312500	54.6	H	0.0	60.5	-5.9	19.4	74.0
26371.437500	54.9	V	0.0	60.3	-5.4	19.1	74.0

Remark: 1. Correction Factor = Antenna factor+ Insertion loss (cable loss + amplifier gain)

Frequency (MHz)	Average (dBuV/m)	Polarization	Azimuth (deg)	Reading value (dBuV/m)	Correct Factor (dB)	Margin (dB)	Limit (dBuV/m)
19058.250000	40.1	V	261.0	45.3	-5.2	13.9	54.0
20115.437500	40.1	V	129.0	45.9	-5.8	13.9	54.0
21837.750000	41.0	V	338.0	49.0	-8.0	13.0	54.0
21959.937500	42.3	V	104.0	50.3	-8.0	11.7	54.0
23699.250000	41.9	V	0.0	47.8	-5.9	12.1	54.0
25996.375000	42.7	V	0.0	48.1	-5.4	11.3	54.0

Remark: 1. Correction Factor = Antenna factor+ Insertion loss (cable loss + amplifier gain)

RE 26.5-40GHz PK+AV

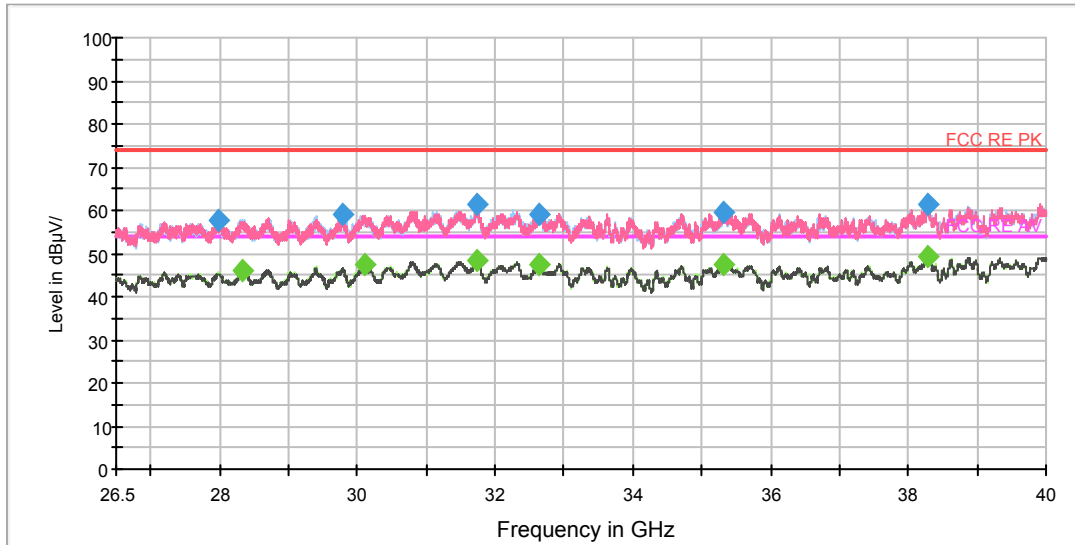

Radiates Emission from 26.5GHz to 40GHz

Frequency (MHz)	Peak (dBuV/m)	Polarization	Azimuth (deg)	Reading value (dBuV/m)	Correct Factor (dB)	Margin (dB)	Limit (dBuV/m)
27978.250000	57.9	H	214.0	59.6	-1.7	16.1	74.0
29788.937500	59.2	V	0.0	59.8	-0.6	14.8	74.0
31738.000000	61.3	H	69.0	61.8	-0.5	12.7	74.0
32640.812500	59.2	H	359.0	59.9	-0.7	14.8	74.0
35312.125000	59.5	H	238.0	60.0	-0.5	14.5	74.0
38295.625000	61.3	V	193.0	59.3	2.0	12.7	74.0

Remark: 1. Correction Factor = Antenna factor+ Insertion loss (cable loss + amplifier gain)

Frequency (MHz)	Average (dBuV/m)	Polarization	Azimuth (deg)	Reading value (dBuV/m)	Correct Factor (dB)	Margin (dB)	Limit (dBuV/m)
28336.000000	46.0	H	0.0	47.5	-1.5	8.0	54.0
30106.187500	47.2	H	0.0	47.6	-0.4	6.8	54.0
31729.562500	48.5	H	214.0	49.0	-0.5	5.5	54.0
32650.937500	47.6	H	0.0	48.3	-0.7	6.4	54.0
35302.000000	47.6	V	52.0	48.1	-0.5	6.4	54.0
38285.500000	49.1	V	0.0	47.1	2.0	4.9	54.0

Remark: 1. Correction Factor = Antenna factor+ Insertion loss (cable loss + amplifier gain)

5790MHz

RE 30M-1GHz QP

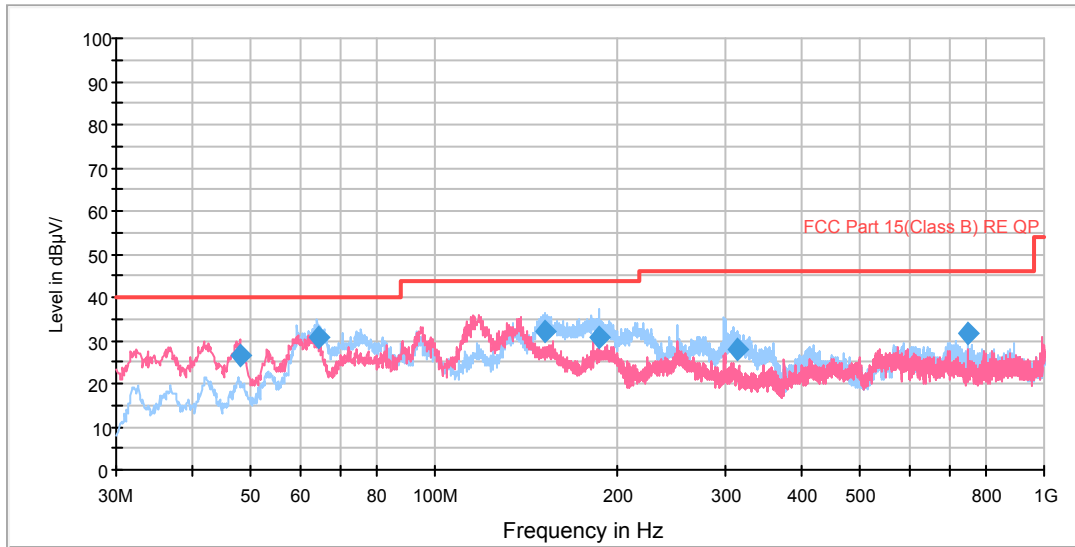

Radiates Emission from 30MHz to 1GHz

Frequency (MHz)	Quasi-Peak (dBuV/m)	Height (cm)	Polarization	Azimuth (deg)	Reading value (dBuV/m)	Correct Factor (dB)	Margin (dB)	Limit (dBuV/m)
47.824190	26.7	101.0	V	83.0	46.9	-20.2	13.3	40.0
64.352981	30.9	130.0	H	25.0	54.6	-23.7	9.1	40.0
151.513769	31.9	130.0	H	62.0	61.1	-29.2	11.6	43.5
186.827416	30.5	130.0	H	356.0	57.9	-27.4	13.0	43.5
314.229250	28.1	105.0	H	291.0	51.3	-23.2	17.9	46.0
749.987500	31.9	103.0	H	139.0	47.3	-15.4	14.1	46.0

- Remark:**
1. Quasi-Peak = Reading value + Correction factor
  2. Correction Factor = Antenna factor+ Insertion loss(cable loss+amplifier gain)
  3. Margin = Limit – Quasi-Peak

RE 1G-3GHz PK+AV

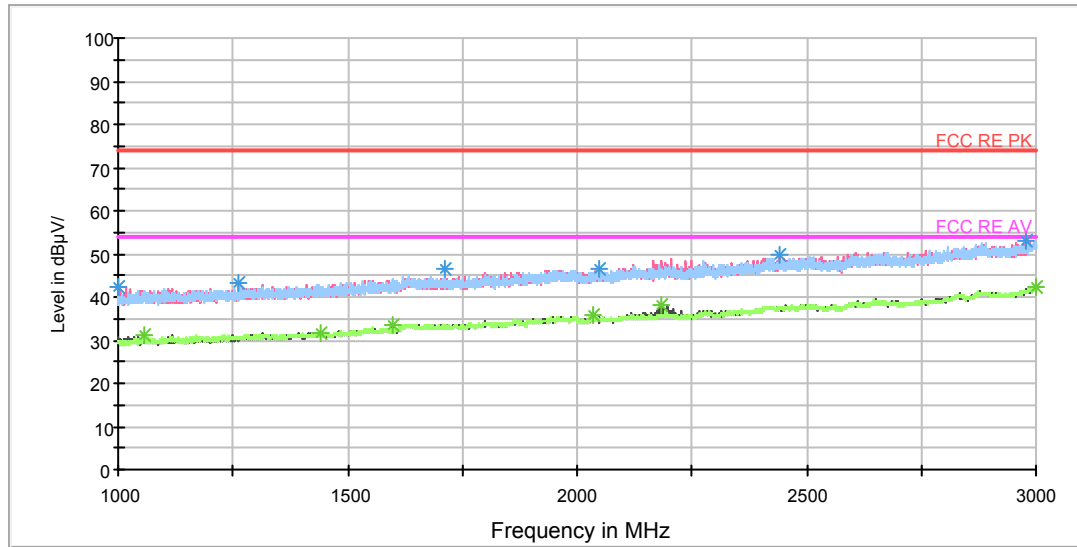

Radiates Emission from 1GHz to 3GHz

Frequency (MHz)	Peak (dBuV/m)	Height (cm)	Polarization	Azimuth (deg)	Reading value (dBuV/m)	Correct Factor (dB)	Margin (dB)	Limit (dBuV/m)
1002.000000	42.3	104.0	V	202.0	51.5	-9.2	31.7	74
1263.000000	43.1	104.0	H	0.0	50.8	-7.7	30.9	74
1712.000000	46.3	104.0	H	12.0	51.1	-4.8	27.7	74
2047.500000	46.5	104.0	V	255.0	49.7	-3.2	27.5	74
2439.500000	49.6	104.0	V	326.0	50.0	-0.4	24.4	74
2978.500000	53.0	104.0	H	276.0	50.8	2.2	21.0	74

Remark: 1. Correction Factor = Antenna factor+ Insertion loss (cable loss + amplifier gain)

Frequency (MHz)	Average (dBuV/m)	Height (cm)	Polarization	Azimuth (deg)	Reading value (dBuV/m)	Correct Factor (dB)	Margin (dB)	Limit (dBuV/m)
1055.000000	31.1	104.0	H	47.0	40.1	-9.0	22.9	54
1441.500000	31.5	104.0	V	121.0	38.4	-6.9	22.5	54
1600.250000	33.7	104.0	V	166.0	40.1	-6.4	20.3	54
2036.750000	35.6	104.0	V	290.0	38.9	-3.3	18.4	54
2184.000000	38.3	104.0	V	183.0	40.5	-2.2	15.7	54
2999.250000	42.2	104.0	V	238.0	39.9	2.3	11.8	54

Remark: 1. Correction Factor = Antenna factor+ Insertion loss (cable loss + amplifier gain)



RE 3-18GHz PK+AV

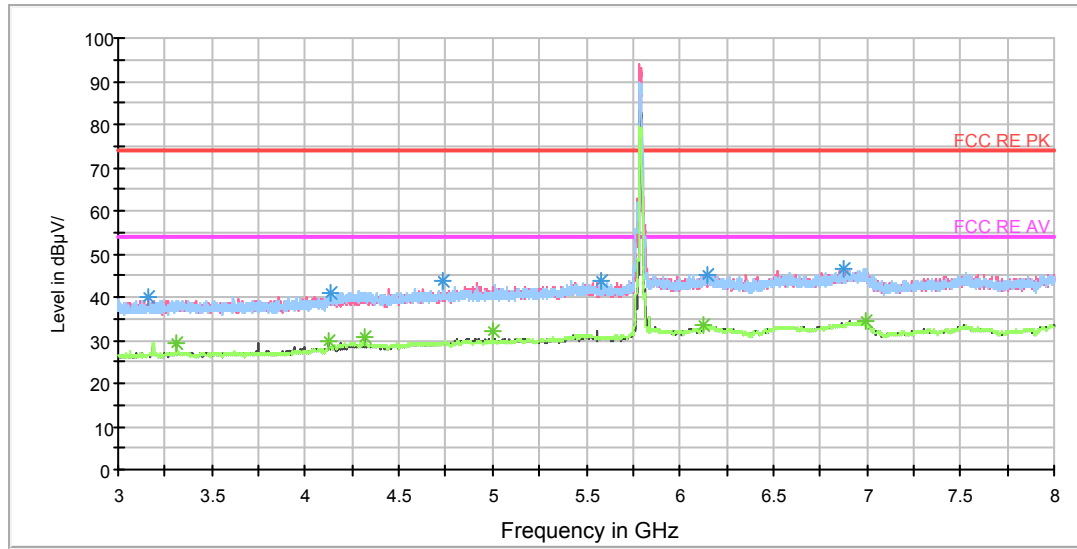

Note: The signal beyond the limit is carrier.  
Radiates Emission from 3GHz to 8GHz

Frequency (MHz)	Peak (dBuV/m)	Height (cm)	Polarization	Azimuth (deg)	Reading value (dBuV/m)	Correct Factor (dB)	Margin (dB)	Limit (dBuV/m)
3163.750000	40.0	105.0	V	252.0	42.9	-2.9	34.0	74
4132.500000	40.8	105.0	H	35.0	41.1	-0.3	33.2	74
4732.500000	43.6	105.0	H	8.0	42.8	0.8	30.4	74
5575.000000	43.8	105.0	H	0.0	40.4	3.4	30.2	74
6146.250000	45.1	105.0	V	0.0	39.6	5.5	28.9	74
6870.625000	46.6	105.0	H	8.0	40.7	5.9	27.4	74

Remark: 1. Correction Factor = Antenna factor+ Insertion loss (cable loss + amplifier gain)

Frequency (MHz)	Average (dBuV/m)	Height (cm)	Polarization	Azimuth (deg)	Reading value (dBuV/m)	Correct Factor (dB)	Margin (dB)	Limit (dBuV/m)
3312.500000	29.5	105.0	V	0.0	31.6	-2.1	24.5	54
4125.000000	29.6	105.0	V	152.0	30.0	-0.4	24.4	54
4312.500000	30.9	105.0	V	0.0	30.3	0.6	23.1	54
5000.000000	31.9	105.0	V	328.0	30.3	1.6	22.1	54
6131.250000	33.4	105.0	V	127.0	28.0	5.4	20.6	54
6998.750000	34.3	105.0	H	0.0	27.8	6.5	19.7	54

Remark: 1. Correction Factor = Antenna factor+ Insertion loss (cable loss + amplifier gain)

RE 3-18GHz PK+AV(YIPU)

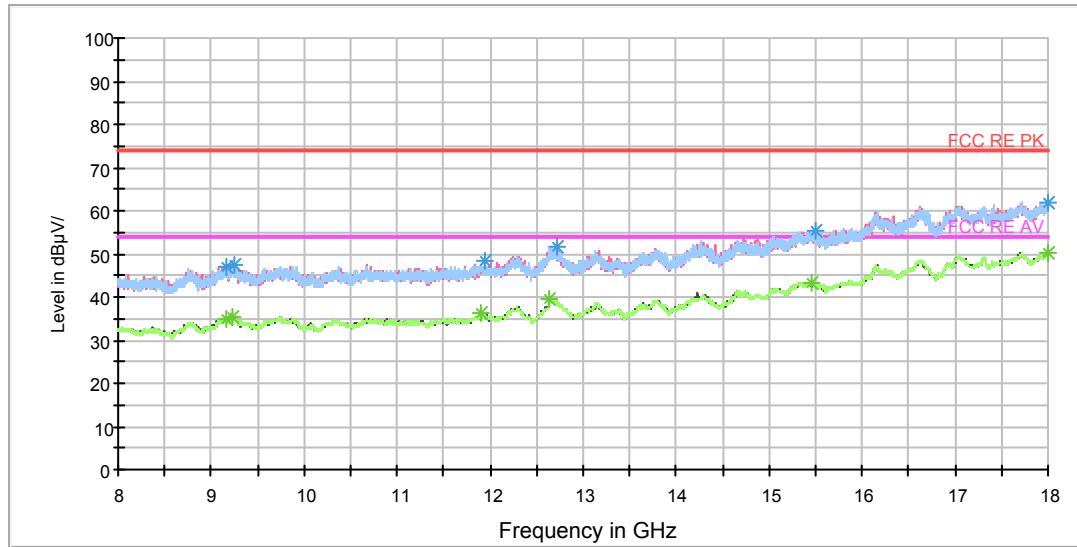

Radiates Emission from 8GHz to 18GHz

Frequency (MHz)	Peak (dBuV/m)	Height (cm)	Polarization	Azimuth (deg)	Reading value (dBuV/m)	Correct Factor (dB)	Margin (dB)	Limit (dBuV/m)
9157.500000	46.8	105.0	V	325.0	36.5	10.3	27.2	74
9256.250000	47.3	105.0	H	38.0	37.8	9.5	26.7	74
11941.250000	48.2	105.0	V	0.0	36.4	11.8	25.8	74
12716.250000	51.5	105.0	H	200.0	37.6	13.9	22.5	74
15497.500000	55.5	105.0	V	0.0	36.1	19.4	18.5	74
17991.250000	62.0	105.0	H	38.0	36.8	25.2	12.0	74

Remark: 1. Correction Factor = Antenna factor+ Insertion loss (cable loss + amplifier gain)

Frequency (MHz)	Average (dBuV/m)	Height (cm)	Polarization	Azimuth (deg)	Reading value (dBuV/m)	Correct Factor (dB)	Margin (dB)	Limit (dBuV/m)
9153.750000	34.9	105.0	H	0.0	24.7	10.2	19.1	54
9237.500000	35.4	105.0	H	172.0	25.5	9.9	18.6	54
11901.250000	36.1	105.0	H	226.0	23.8	12.3	17.9	54
12640.000000	39.7	105.0	V	0.0	25.1	14.6	14.3	54
15448.750000	43.4	105.0	H	226.0	23.9	19.5	10.6	54
18000.000000	50.3	105.0	H	38.0	24.8	25.5	3.7	54

Remark: 1. Correction Factor = Antenna factor+ Insertion loss (cable loss + amplifier gain)

RE 18-26.5GHz PK+AV

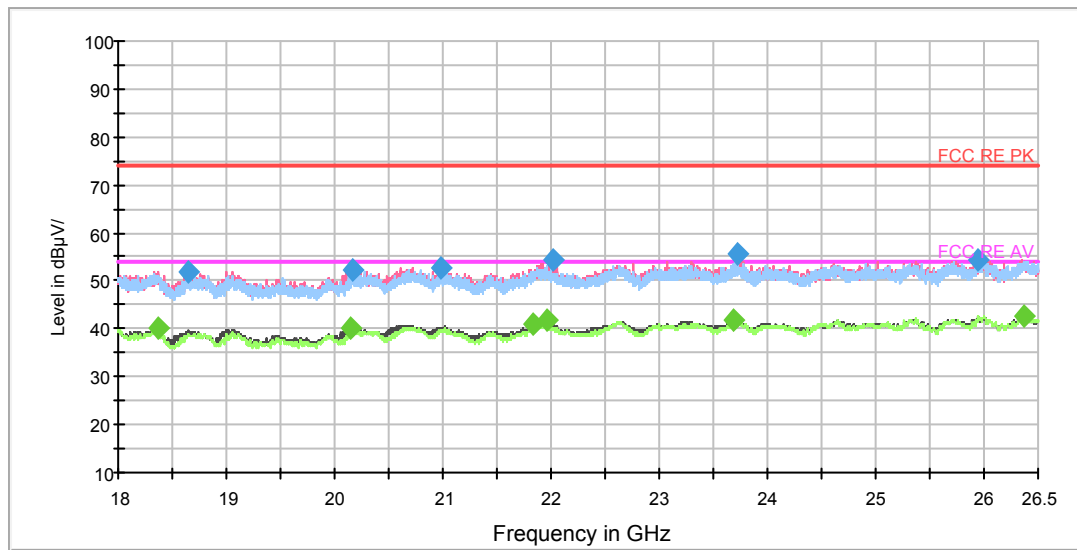

Radiates Emission from 18GHz to 26.5GHz

Frequency (MHz)	Peak (dBuV/m)	Polarization	Azimuth (deg)	Reading value (dBuV/m)	Correct Factor (dB)	Margin (dB)	Limit (dBuV/m)
18639.625000	52.0	V	0.0	56.2	-4.2	22.0	74.0
20164.312500	52.5	V	0.0	58.3	-5.8	21.5	74.0
20978.187500	52.7	V	340.0	60.1	-7.4	21.3	74.0
22020.500000	54.2	V	157.0	62.1	-7.9	19.8	74.0
23731.125000	55.5	V	0.0	61.4	-5.9	18.5	74.0
25948.562500	54.3	H	147.0	59.7	-5.4	19.7	74.0

Remark: 1. Correction Factor = Antenna factor+ Insertion loss (cable loss + amplifier gain)

Frequency (MHz)	Average (dBuV/m)	Polarization	Azimuth (deg)	Reading value (dBuV/m)	Correct Factor (dB)	Margin (dB)	Limit (dBuV/m)
18369.750000	40.0	H	0.0	43.4	-3.4	14.0	54.0
20149.437500	40.1	V	157.0	45.9	-5.8	13.9	54.0
21837.750000	40.8	V	0.0	48.8	-8.0	13.2	54.0
21958.875000	41.9	V	0.0	49.9	-8.0	12.1	54.0
23688.625000	41.9	V	0.0	47.8	-5.9	12.1	54.0
26370.375000	42.7	V	340.0	48.1	-5.4	11.3	54.0

Remark: 1. Correction Factor = Antenna factor+ Insertion loss (cable loss + amplifier gain)

RE 26.5-40GHz PK+AV

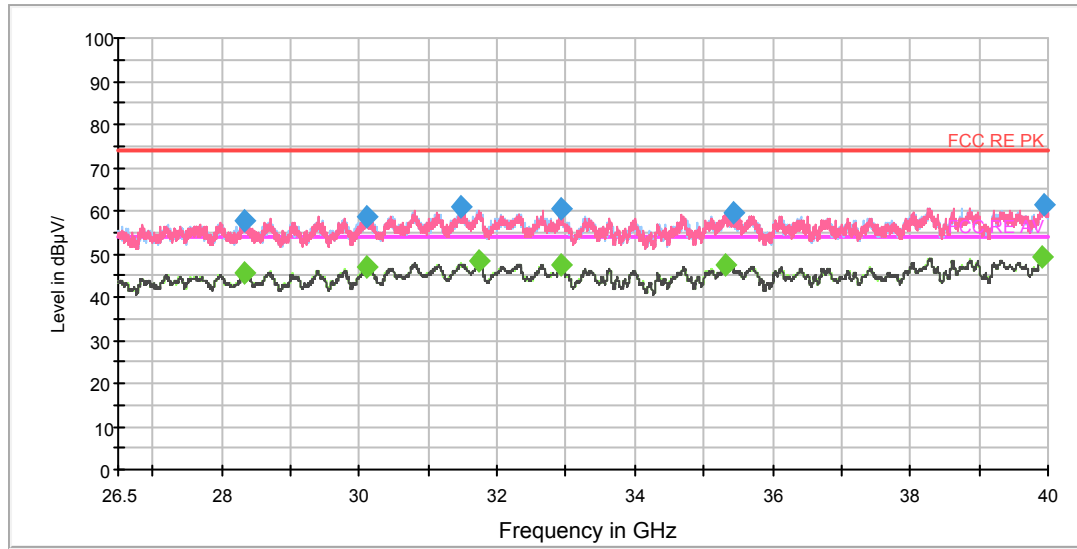

Radiates Emission from 26.5GHz to 40GHz

Frequency (MHz)	Peak (dBuV/m)	Polarization	Azimuth (deg)	Reading value (dBuV/m)	Correct Factor (dB)	Margin (dB)	Limit (dBuV/m)
28329.250000	57.7	V	290.0	59.2	-1.5	16.3	74.0
30096.062500	58.6	V	146.0	59.0	-0.4	15.4	74.0
31474.750000	60.8	V	217.0	61.3	-0.5	13.2	74.0
32939.500000	60.5	H	167.0	61.3	-0.8	13.5	74.0
35428.562500	59.4	V	290.0	59.9	-0.5	14.6	74.0
39934.187500	61.5	H	215.0	59.2	2.3	12.5	74.0

Remark: 1. Correction Factor = Antenna factor+ Insertion loss (cable loss + amplifier gain)

Frequency (MHz)	Average (dBuV/m)	Polarization	Azimuth (deg)	Reading value (dBuV/m)	Correct Factor (dB)	Margin (dB)	Limit (dBuV/m)
28341.062500	45.6	V	0.0	47.1	-1.5	8.4	54.0
30102.812500	46.8	H	237.0	47.2	-0.4	7.2	54.0
31743.062500	48.4	H	284.0	48.9	-0.5	5.6	54.0
32939.500000	47.4	H	167.0	48.2	-0.8	6.6	54.0
35313.812500	47.5	H	142.0	48.0	-0.5	6.5	54.0
39900.437500	49.2	V	6.0	46.9	2.3	4.8	54.0

Remark: 1. Correction Factor = Antenna factor+ Insertion loss (cable loss + amplifier gain)



5840MHz

RE 30M-1GHz QP

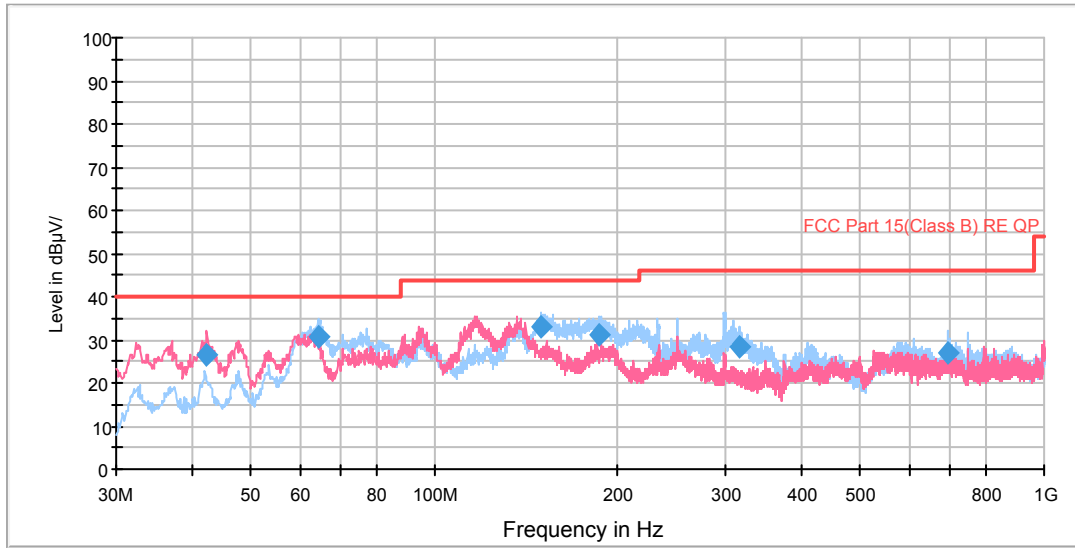

Radiates Emission from 30MHz to 1GHz

Frequency (MHz)	Quasi-Peak (dBuV/m)	Height (cm)	Polarization	Azimuth (deg)	Reading value (dBuV/m)	Correct Factor (dB)	Margin (dB)	Limit (dBuV/m)
42.300634	26.7	121.0	V	73.0	47.1	-20.4	13.3	40.0
64.474535	30.9	130.0	H	22.0	54.6	-23.7	9.1	40.0
149.656725	33.1	130.0	H	149.0	62.3	-29.2	10.4	43.5
185.462681	30.9	130.0	H	334.0	58.3	-27.4	12.6	43.5
315.154000	28.2	105.0	H	289.0	51.4	-23.2	17.8	46.0
696.973750	27.1	103.0	H	137.0	42.2	-15.1	18.9	46.0

- Remark: 1. Quasi-Peak = Reading value + Correction factor  
 2. Correction Factor = Antenna factor+ Insertion loss(cable loss+amplifier gain)  
 3. Margin = Limit – Quasi-Peak

RE 1G-3GHz PK+AV

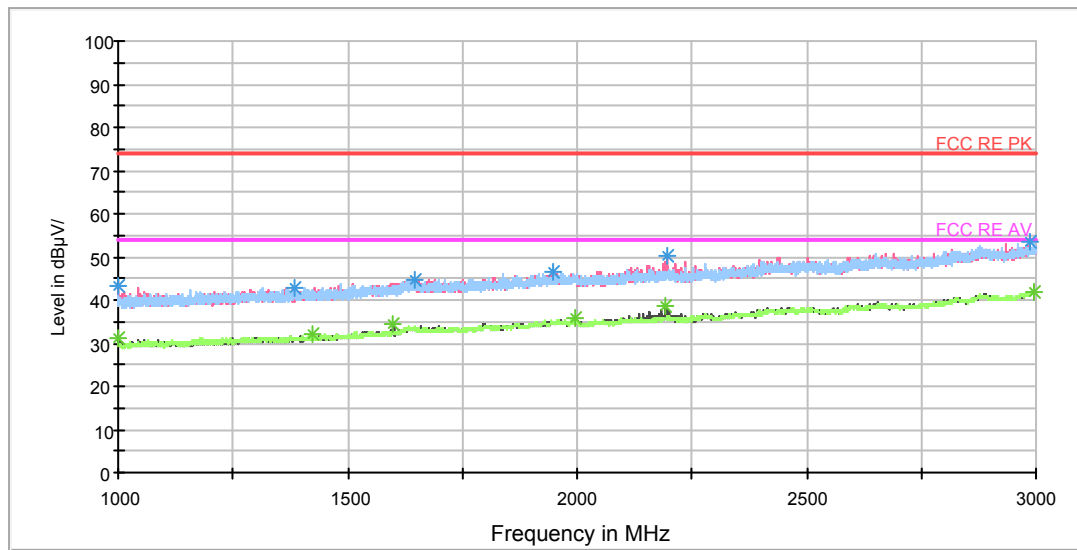

Radiates Emission from 1GHz to 3GHz

Frequency (MHz)	Peak (dBuV/m)	Height (cm)	Polarization	Azimuth (deg)	Reading value (dBuV/m)	Correct Factor (dB)	Margin (dB)	Limit (dBuV/m)
1000.000000	43.1	104.0	V	0.0	52.3	-9.2	30.9	74
1383.250000	43.0	104.0	H	27.0	50.0	-7.0	31.0	74
1645.250000	44.8	104.0	H	9.0	49.7	-4.9	29.2	74
1946.000000	46.6	104.0	V	236.0	49.9	-3.3	27.4	74
2197.250000	50.0	104.0	V	188.0	52.1	-2.1	24.0	74
2985.500000	53.4	104.0	V	254.0	51.2	2.2	20.6	74

Remark: 1. Correction Factor = Antenna factor+ Insertion loss (cable loss + amplifier gain)

Frequency (MHz)	Average (dBuV/m)	Height (cm)	Polarization	Azimuth (deg)	Reading value (dBuV/m)	Correct Factor (dB)	Margin (dB)	Limit (dBuV/m)
1000.000000	31.3	104.0	V	0.0	40.5	-9.2	22.7	54
1425.500000	32.0	104.0	H	0.0	38.9	-6.9	22.0	54
1600.000000	34.5	104.0	V	161.0	40.9	-6.4	19.5	54
1996.500000	35.7	104.0	V	41.0	39.0	-3.3	18.3	54
2194.000000	38.8	104.0	V	188.0	40.9	-2.1	15.2	54
2995.750000	42.1	104.0	V	179.0	39.8	2.3	11.9	54

Remark: 1. Correction Factor = Antenna factor+ Insertion loss (cable loss + amplifier gain)