



# RF TEST REPORT

**Applicant** Huawei Technologies Co. ,Ltd.  
**FCC ID** QISEA680-950  
**Product** LTE DAU  
**Model** eA680-950  
**Report No.** R1903H0045-R1  
**Issue Date** June 11, 2019

TA Technology (Shanghai) Co., Ltd. tested the above equipment in accordance with the requirements in **FCC CFR47 Part 15E (2018)**. The test results show that the equipment tested is capable of demonstrating compliance with the requirements as documented in this report.

Performed by: Peng Tao

Approved by: Kai Xu

---

## TA Technology (Shanghai) Co., Ltd.

No.145, Jintang Rd, Tangzhen Industry Park, Pudong Shanghai, China

TEL: +86-021-50791141/2/3

FAX: +86-021-50791141/2/3-8000



## TABLE OF CONTENT

1. Test Laboratory .....	4
1.1. Notes of the test report.....	4
1.2. Test facility .....	4
1.3. Testing Location.....	5
2. General Description of Equipment under Test.....	6
3. Applied Standards .....	7
4. Test Configuration .....	8
5. Test Case Results .....	9
5.1. Occupied Bandwidth .....	9
5.2. Average Power Output –Conducted.....	13
5.3. Frequency Stability.....	15
5.4. Power Spectral Density.....	20
5.5. Unwanted Emission .....	23
5.6. Conducted spurious emissions at antenna port .....	47
5.7. Conducted Emission .....	52
6. Main Test Instruments.....	59
ANNEX A: Product Change Description .....	60

## Summary of measurement results

Number	Summary of measurements of results	Clause in FCC rules	Verdict
1	Average conducted output power	15.407(a)	Add 2CA Test
2	Occupied bandwidth	15.407(e)	Add 2CA Test
3	Frequency stability	15.407(g)	Add 2CA Test
4	Power spectral density	15.407(a)	Add 2CA Test
5	Unwanted Emissions	15.407(b)	Refer to the Original
6	Conducted spurious emissions at antenna port	15.407(b)	Refer to the Original
7	Conducted Emissions	15.207	Refer to the Original

Date of Testing: May 1, 2017~ May 5, 2017 and July 16, 2017 and April 3, 2019~ June 11, 2019

**eA680-950 (Report No: R1903H0045-R1) is a variant model of eA680-950 (Report No: RHA1704-0043RF02R5). The detailed product change description please refers to the ANNEX A.**



## 1. Test Laboratory

### 1.1. Notes of the test report

This report shall not be reproduced in full or partial, without the written approval of **TA technology (shanghai) co., Ltd.** The results documented in this report apply only to the tested sample, under the conditions and modes of operation as described herein. Measurement Uncertainties were not taken into account and are published for informational purposes only. This report is written to support regulatory compliance of the applicable standards stated above.

### 1.2. Test facility

#### **CNAS (accreditation number: L2264)**

TA Technology (Shanghai) Co., Ltd. has obtained the accreditation of China National Accreditation Service for Conformity Assessment (CNAS).

#### **FCC (Designation number: CN1179, Test Firm Registration Number: 446626)**

TA Technology (Shanghai) Co., Ltd. has been listed on the US Federal Communications Commission list of test facilities recognized to perform electromagnetic emissions measurements.

#### **IC (recognition number is 8510A)**

TA Technology (Shanghai) Co., Ltd. has been listed by industry Canada to perform electromagnetic emission measurement.

#### **VCCI (recognition number is C-4595, T-2154, R-4113, G-10766)**

TA Technology (Shanghai) Co., Ltd. has been listed by industry Japan to perform electromagnetic emission measurement.

#### **A2LA (Certificate Number: 3857.01)**

TA Technology (Shanghai) Co., Ltd. has been listed by American Association for Laboratory Accreditation to perform electromagnetic emission measurement.



### 1.3. Testing Location

Company: TA Technology (Shanghai) Co., Ltd.  
Address: No.145, Jintang Rd, Tangzhen Industry Park, Pudong  
City: Shanghai  
Post code: 201201  
Country: P. R. China  
Contact: Xu Kai  
Telephone: +86-021-50791141/2/3  
Fax: +86-021-50791141/2/3-8000  
Website: <http://www.ta-shanghai.com>  
E-mail: [xukai@ta-shanghai.com](mailto:xukai@ta-shanghai.com)

## 2. General Description of Equipment under Test

### Client Information

<b>Applicant</b>	Huawei Technologies Co., Ltd.
<b>Applicant address</b>	Administration Building, Headquarters of Huawei Technologies Co., Ltd., Bantian, Longgang District, Shenzhen, 518129, P.R.China.
<b>Manufacturer</b>	Huawei Technologies Co., Ltd.
<b>Manufacturer address</b>	Administration Building, Headquarters of Huawei Technologies Co., Ltd., Bantian, Longgang District, Shenzhen, 518129, P.R.China.

### General information

EUT Description			
Model	eA680-950		
IMEI	864756030037016		
Hardware Version	Ver.A		
Software Version	V100R001		
Power Supply	AC adapter		
Antenna Type	Internal Antenna		
Antenna Gain	16dBi		
additional beamforming gain	NA		
Test Mode(s)	5725 MHz - 5850 MHz		
Modulation Type	QPSK/16QAM/64QAM		
Max. Conducted Power	17.35 dBm		
Operating Frequency Range(s)	Mode	Tx (MHz)	Rx (MHz)
	5G	5725 - 5850	5725 - 5850
Operating temperature range:	-20 ° C to 50° C		
Operating voltage range:	40.8V to 55.2 V		
State DC voltage:	48V		
EUT Accessory			
Adapter	Manufacture: DONGGUAN SHILONG FUHUA ELECTRONIC CO., LTD. Model : PoE35-54A		
Note: The information of the EUT is declared by the manufacturer.			



### 3. Applied Standards

According to the specifications of the manufacturer, it must comply with the requirements of the following standards:

**FCC CFR47 Part 15E (2018)** Unlicensed National Information Infrastructure Devices

**ANSI C63.10 (2013)**

**KDB 789033 D02 General UNII Test Procedures New Rules v02r01**

## 4. Test Configuration

### Test Mode

The EUT was programmed to be in continuously transmitting mode and the transmit duty cycle is not less than 98%.

The EUT has been associated with peripherals and configuration operated in a manner tended to maximize its emission characteristics in a typical application.

The radiated emission was measured in the following position: EUT stand-up position (Z axis), lie-down position (X, Y axis). The worst emission was found in stand-up position (Z axis) and the worst case was recorded.

In order to find the worst case condition, Pre-tests are needed at the presence of different data rate. Preliminary tests have been done on all the configuration for confirming worst case. Data rate below means worst-case rate of each test item.



## 5. Test Case Results

### 5.1. Occupied Bandwidth

#### Ambient condition

Temperature	Relative humidity	Pressure
23°C ~25°C	45%~50%	101.5kPa

#### Method of Measurement

The EUT was connected to the spectrum analyzer through an external attenuator (20dB) and a known loss cable.

Set RBW = 100 kHz, VBW  $\geq 3 \times$  RBW, measure the maximum width of the emission that is constrained by the frequencies associated with the two outermost amplitude points (upper and lower frequencies) that are attenuated by 6 dB relative to the maximum level measured in the fundamental emission.

Set RBW = 1 % to 5 % of the OBW, VBW  $\geq 3 \times$  RBW, Use the 99 % power bandwidth function of the instrument (if available).

If the instrument does not have a 99 % power bandwidth function, the trace data points are recovered and directly summed in power units. The recovered amplitude data points, beginning at the lowest frequency, are placed in a running sum until 0.5 % of the total is reached; that frequency is recorded as the lower frequency. The process is repeated until 99.5 % of the total is reached; that frequency is recorded as the upper frequency. The 99% occupied bandwidth is the difference between these two frequencies.

#### Test Setup

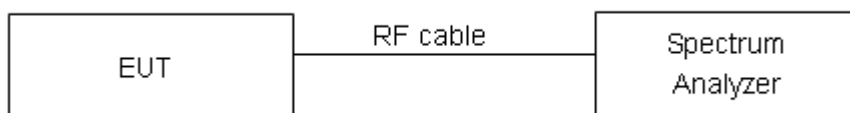

#### Limits

Rule FCC Part §15.407(e)

Within the 5.725-5.85 GHz band, the minimum 6 dB bandwidth of U-NII devices shall be at least 500 kHz.

#### Measurement Uncertainty

The assessed measurement uncertainty to ensure 95% confidence level for the normal distribution is with the coverage factor  $k = 2$ ,  $U = 936$  Hz.

**Test Results:**

Carrier frequency (MHz)	99% bandwidth (MHz)	Minimum -6 dB bandwidth (MHz)	Limit (kHz)	Conclusion
5735	17.891	17.98	500	PASS
5790	17.879	17.98	500	PASS
5840	17.888	18.00	500	PASS

**2CA**

Carrier frequency (MHz)	99% bandwidth (MHz)	Minimum -6 dB bandwidth (MHz)	Limit (kHz)	Conclusion	
5735	5744.9	37.085	18.07	500	PASS
5754.8					
5785	5794.9	37.175	31.49	500	PASS
5804.8					
5820	5829.9	36.176	18.59	500	PASS
5839.8					

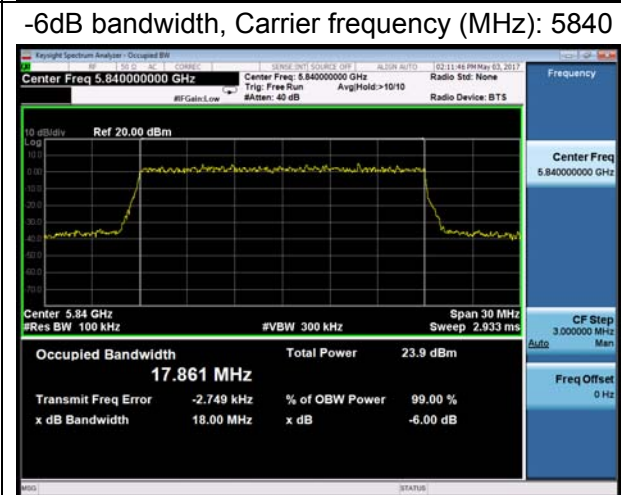
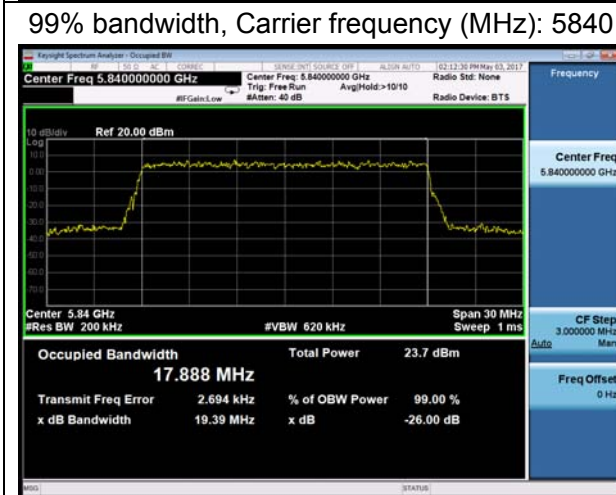
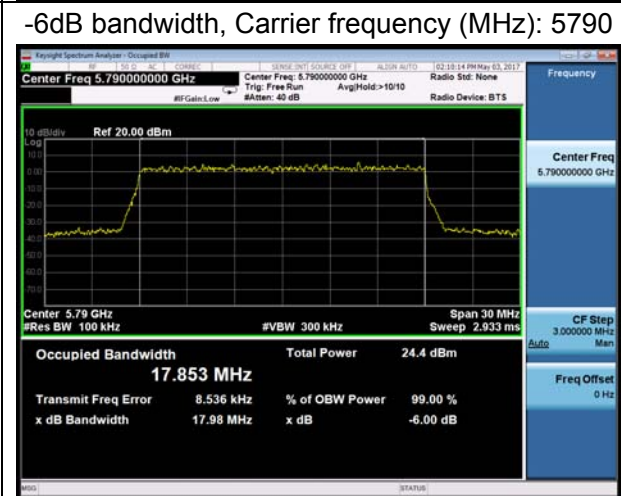
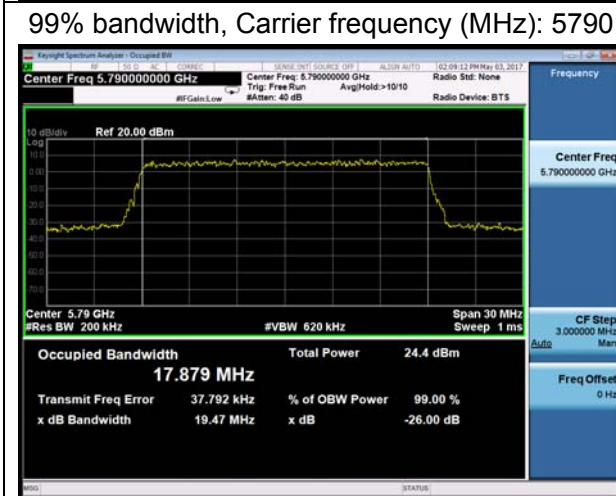
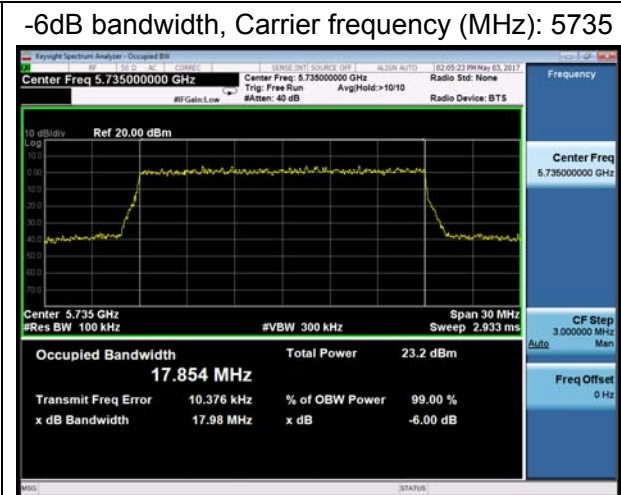
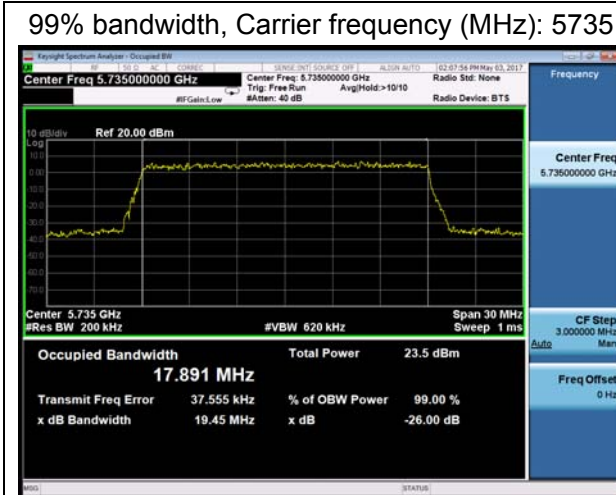



2CA

99% bandwidth, Carrier frequency (MHz): 5744.9

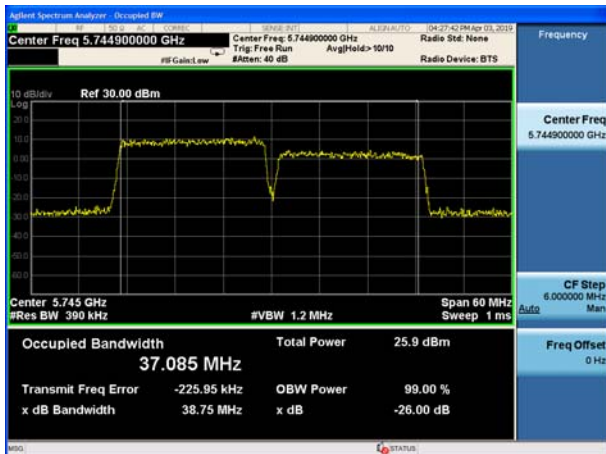

-6dB bandwidth, Carrier frequency (MHz):5744.9

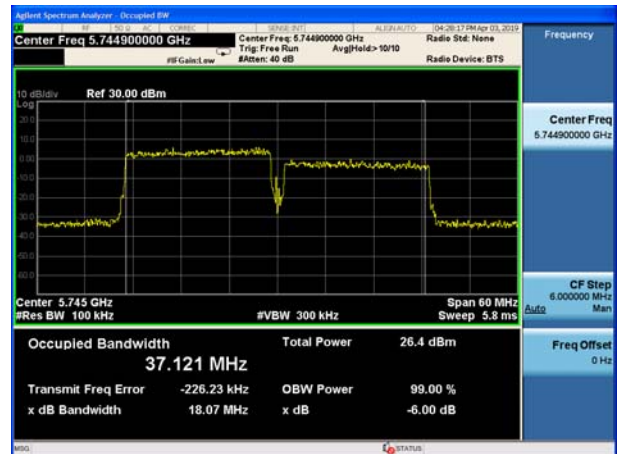

99% bandwidth, Carrier frequency (MHz): 5794.9

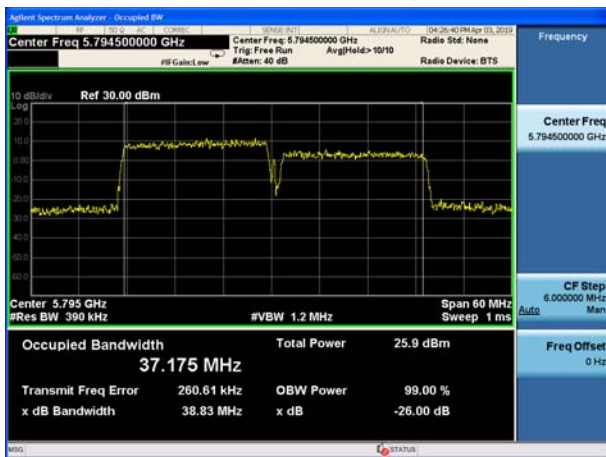

-6dB bandwidth, Carrier frequency (MHz):5794.9

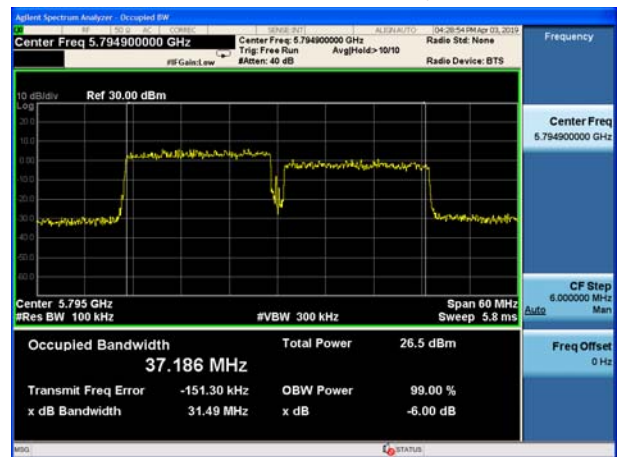

99% bandwidth, Carrier frequency (MHz): 5829.9

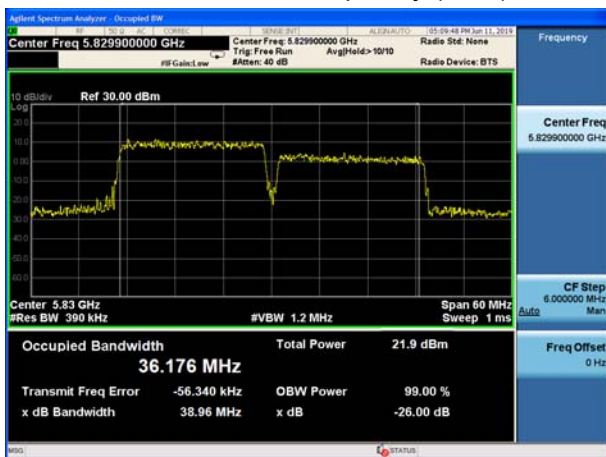

-6dB bandwidth, Carrier frequency (MHz):5829.9

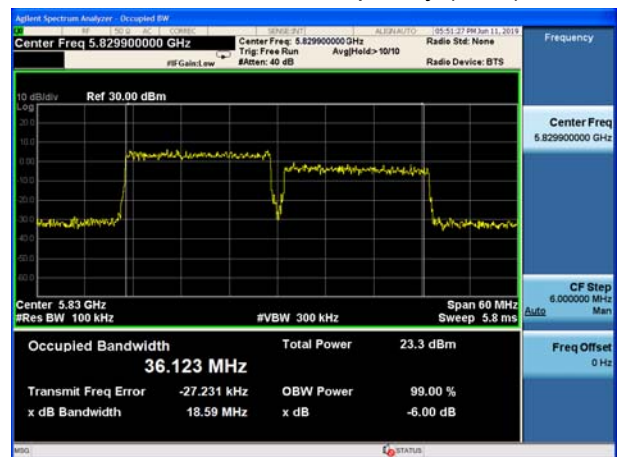

## 5.2. Average Power Output –Conducted

### Ambient condition

Temperature	Relative humidity	Pressure
23°C ~25°C	45%~50%	101.5kPa

### Methods of Measurement

During the process of the testing, The EUT was connected to the average power meter through an external attenuator and a known loss cable. The EUT is max power transmission with proper modulation. We use Maximum average Conducted Output Power Level Method in KDB789033 for this test

### Test Setup

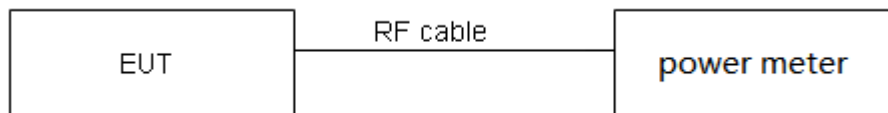

### Limits

Rule FCC Part 15.407(a)(1)(2)(3)

For the band 5.725-5.85 GHz, the maximum conducted output power over the frequency band of operation shall not exceed 1 W. In addition, the maximum power spectral density shall not exceed 30 dBm in any 500-kHz band. If transmitting antennas of directional gain greater than 6 dBi are used, both the maximum conducted output power and the maximum power spectral density shall be reduced by the amount in dB that the directional gain of the antenna exceeds 6 dBi.

### Measurement Uncertainty

The assessed measurement uncertainty to ensure 95% confidence level for the normal distribution is with the coverage factor  $k = 2$ ,  $U = 0.44$  dB.

**Test Results**

Carrier frequency (MHz)	Average Output Power (dBm)	Limit (dBm)	Conclusion
5735	17.35	20.00	PASS
5790	16.44	20.00	PASS
5840	16.01	20.00	PASS

**2CA**

Carrier frequency (MHz)		Average Output Power (dBm)	Limit (dBm)	Conclusion
5735	5744.9	13.66	20.00	PASS
5754.8				
5785	5794.9	15.96	20.00	PASS
5804.8				
5820	5829.9	15.37	20.00	PASS
5839.8				

### 5.3. Frequency Stability

#### Ambient condition

Temperature	Relative humidity	Pressure
23°C ~25°C	45%~50%	101.5kPa

#### Method of Measurement

##### 1. Frequency stability with respect to ambient temperature

a) Supply the EUT with a nominal ac voltage or install a new or fully charged battery in the EUT. If possible, a dummy load shall be connected to the EUT because an antenna near the metallic walls of an environmental test chamber could affect the output frequency of the EUT. If the EUT is equipped with a permanently attached, adjustable-length antenna, then the EUT shall be placed in the center of the chamber with the antenna adjusted to the shortest length possible. Turn ON the EUT and tune it to one of the number of frequencies shown in 5.6.

b) Couple the unlicensed wireless device output to the measuring instrument by connecting an antenna to the measuring instrument with a suitable length of coaxial cable and placing the measuring antenna near the EUT (e.g., 15 cm away), or by connecting a dummy load to the measuring instrument, through an attenuator if necessary.

c) Adjust the location of the measurement antenna and the controls on the measurement instrument to obtain a suitable signal level (i.e., a level that will not overload the measurement instrument but is strong enough to allow measurement of the operating or fundamental frequency of the EUT).

d) Turn the EUT OFF and place it inside the environmental temperature chamber. For devices that have oscillator heaters, energize only the heater circuit.

e) Set the temperature control on the chamber to the highest specified in the regulatory requirements for the type of device and allow the oscillator heater and the chamber temperature to stabilize.

f) While maintaining a constant temperature inside the environmental chamber, turn the EUT ON and record the operating frequency at startup, and at 2 minutes, 5 minutes, and 10 minutes after the EUT is energized. Four measurements in total are made.

g) Measure the frequency at each of frequencies specified in 5.6.

h) Switch OFF the EUT but do not switch OFF the oscillator heater.

i) Lower the chamber temperature by not more than 10 C, and allow the temperature inside the chamber to stabilize.

j) Repeat step f) through step i) down to the lowest specified temperature.

##### 2. Frequency stability when varying supply voltage

Unless otherwise specified, these tests shall be made at ambient room temperature (+15 C to +25

C). An antenna shall be connected to the antenna output terminals of the EUT if possible. If the EUT is equipped with or uses an adjustable-length antenna, then it shall be fully extended.

a) Supply the EUT with nominal voltage or install a new or fully charged battery in the EUT. Turn ON the EUT and couple its output to a frequency counter or other frequency-measuring instrument.



- b) Tune the EUT to one of the number of frequencies required in 5.6. Adjust the location of the measurement antenna and the controls on the measurement instrument to obtain a suitable signal level (i.e., a level that will not overload the measurement instrument but is strong enough to allow measurement of the operating or fundamental frequency of the EUT).
- c) Measure the frequency at each of the frequencies specified in 5.6.
- d) Repeat the above procedure at 85% and 115% of the nominal supply voltage.

**Limit**

Manufacturers of U-NII devices are responsible for ensuring frequency stability such that an emission is maintained within the band of operation under all conditions of normal operation as specified in the users manual.

**Measurement Uncertainty**

The assessed measurement uncertainty to ensure 95% confidence level for the normal distribution is with the coverage factor  $k = 2$ ,  $U = 936\text{Hz}$



**Test Results**

Voltage (V)	Temperature (°C)	Test Results			
		5735MHz			
		1min	2min	5min	10min
48	-20	5735.009	5735.008	5735.001	5734.991
48	-10	5735.017	5734.998	5734.995	5734.985
48	0	5735.011	5735.005	5734.999	5734.980
48	10	5735.014	5734.997	5735.008	5734.982
48	20	5735.010	5735.007	5735.006	5734.981
48	30	5735.012	5735.002	5735.006	5734.983
48	40	5735.020	5735.008	5735.008	5734.980
48	50	5735.021	5735.008	5735.012	5734.974
40.8	20	5735.016	5735.006	5735.004	5734.967
55.2	20	5735.008	5735.003	5735.004	5734.964
MHz		0.008	-0.003	-0.005	-0.036
PPM		1.3838987	-0.45329074	-0.8698842	-6.2381392

Voltage (V)	Temperature (°C)	Test Results			
		5790MHz			
		1min	2min	5min	10min
48	-20	5789.998	5790.003	5789.996	5790.004
48	-10	5790.001	5790.008	5790.004	5790.007
48	0	5790.002	5790.016	5790.002	5790.014
48	10	5790.007	5790.007	5790.003	5790.016
48	20	5790.001	5790.006	5790.007	5790.019
48	30	5790.003	5790.015	5790.013	5790.012
48	40	5789.996	5790.008	5790.022	5790.020
48	50	5790.003	5790.014	5790.026	5790.013
40.8	20	5790.011	5790.010	5790.021	5790.019
55.2	20	5790.020	5790.013	5790.027	5790.014
MHz		-0.004	0.003	-0.004	0.004
PPM		-0.614282	0.595512067	-0.7232005	0.68497153



Voltage (V)	Temperature (°C)	Test Results			
		5840MHz			
		1min	2min	5min	10min
48	-20	5840.007	5839.999	5840.007	5839.997
48	-10	5840.001	5840.002	5840.002	5839.993
48	0	5839.994	5840.001	5840.001	5839.990
48	10	5839.991	5839.992	5840.007	5839.998
48	20	5839.983	5839.997	5840.014	5839.995
48	30	5839.991	5839.992	5840.004	5840.000
48	40	5839.991	5839.982	5840.001	5839.993
48	50	5839.984	5839.976	5839.998	5839.989
40.8	20	5839.992	5839.969	5840.000	5839.991
55.2	20	5839.997	5839.964	5839.997	5839.991
MHz		-0.017	-0.036	-0.003	-0.011
PPM		-2.924426	-6.08147743	-0.5982631	-1.8419499

## 2CA

Voltage (V)	Temperature (°C)	Test Results			
		5744.9MHz			
		1min	2min	5min	10min
48	-20	5744.895291	5744.894536	5744.889514	5744.889167
48	-10	5744.898694	5744.887845	5744.882098	5744.886139
48	0	5744.894699	5744.883800	5744.873198	5744.879260
48	10	5744.894533	5744.878568	5744.867768	5744.871846
48	20	5744.892601	5744.872691	5744.866620	5744.869816
48	30	5744.886510	5744.865812	5744.863908	5744.867035
48	40	5744.885805	5744.858333	5744.854918	5744.860372
48	50	5744.876829	5744.849838	5744.849594	5744.859806
40.8	20	5744.875259	5744.848581	5744.839880	5744.853374
55.2	20	5744.875086	5744.844477	5744.838294	5744.850502
MHz		-0.024914	-0.055523	-0.061706	-0.049498
PPM		-4.336673	-9.664664	-10.741069	-8.616009



Voltage (V)	Temperature (°C)	Test Results			
		5794.9MHz			
		1min	2min	5min	10min
48	-20	5794.897229	5794.889283	5794.882282	5794.872638
48	-10	5794.892596	5794.888109	5794.874691	5794.871447
48	0	5794.889449	5794.888057	5794.869989	5794.865455
48	10	5794.885037	5794.879817	5794.860144	5794.857905
48	20	5794.875039	5794.876918	5794.850200	5794.854971
48	30	5794.868921	5794.873054	5794.841804	5794.853099
48	40	5794.861041	5794.870604	5794.841493	5794.845082
48	50	5794.851482	5794.867276	5794.833169	5794.837248
40.8	20	5794.846960	5794.861347	5794.829245	5794.835300
55.2	20	5794.846768	5794.852878	5794.822276	5794.829715
MHz		-0.053232	-0.047122	-0.077724	-0.070285
PPM		-9.185932	-8.131637	-13.412398	-12.128830

Voltage (V)	Temperature (°C)	Test Results			
		5829.9MHz			
		1min	2min	5min	10min
48	-20	5839.901491	5839.897874	5839.895956	5839.886397
48	-10	5839.894520	5839.894914	5839.886449	5839.882110
48	0	5839.884693	5839.891534	5839.877676	5839.879841
48	10	5839.882115	5839.890434	5839.874457	5839.878163
48	20	5839.874725	5839.890069	5839.871784	5839.877294
48	30	5839.872879	5839.888243	5839.870643	5839.868381
48	40	5839.863280	5839.883648	5839.865050	5839.862583
48	50	5839.860288	5839.877355	5839.864874	5839.859933
40.8	20	5839.854927	5839.874518	5839.858383	5839.850259
55.2	20	5839.853104	5839.866482	5839.858000	5839.847067
MHz		-0.046896	-0.033518	-0.042000	-0.052933
PPM		-8.030233	-5.739470	-7.191940	-9.064038

### 5.4. Power Spectral Density

#### Ambient condition

Temperature	Relative humidity	Pressure
23°C ~25°C	45%~50%	101.5kPa

#### Method of Measurement

The EUT was connected to the spectrum analyzer through an external attenuator (20dB) and a known loss cable.

Set RBW = 510 kHz, VBW =1.5MHz for the band 5.725-5.85 GHz

The conducted PSD is measured at each antenna port. The measured results at the various antenna ports are then summed mathematically.

#### Test setup

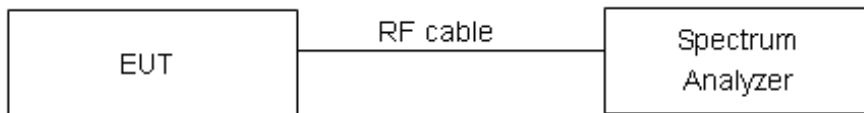

#### Limits

Rule FCC Part 15.407(a)(3)

For the band 5.725-5.85 GHz, the maximum power spectral density shall not exceed 30 dBm in any 500-kHz band. If transmitting antennas of directional gain greater than 6 dBi are used, both the maximum conducted output power and the maximum power spectral density shall be reduced by the amount in dB that the directional gain of the antenna exceeds 6 dBi.

Frequency Bands/MHz	Limits
5725-5850	30dBm/500kHz

#### Measurement Uncertainty

The assessed measurement uncertainty to ensure 95% confidence level for the normal distribution is with the coverage factor  $k = 2$ ,  $U= 0.75$ dB.

**Test Results:**

Note: Power Spectral Density =Read Value+Duty cycle correction factor

Carrier frequency (MHz)	Power Spectral Density (dBm /MHz)	Limit (dBm/500kHz)	Conclusion
5735	1.082	20.00	PASS
5790	1.694	20.00	PASS
5840	1.620	20.00	PASS

**2CA**

Carrier frequency (MHz)	Power Spectral Density (dBm /MHz)	Limit (dBm/500kHz)	Conclusion	
5735	5744.9	-1.039	20.00	PASS
5754.8				
5785	5794.9	-0.409	20.00	PASS
5804.8				
5820	5829.9	-1.335	20.00	PASS
5839.8				



Carrier Frequency (MHz): 5735

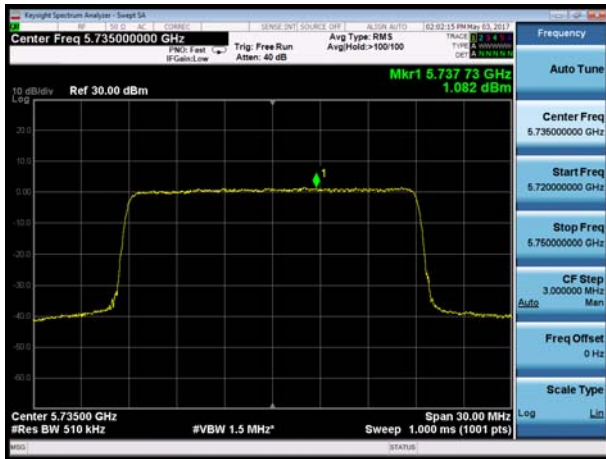

Carrier Frequency (MHz): 5744.9



Carrier Frequency (MHz): 5790



Carrier Frequency (MHz): 5794.9

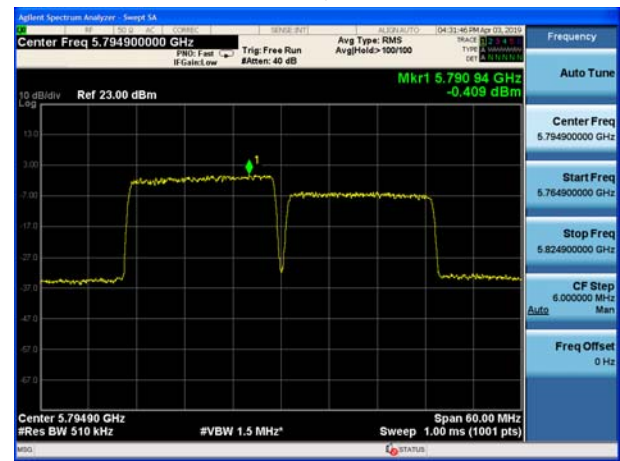

Carrier Frequency (MHz): 5840



Carrier Frequency (MHz): 5829.9

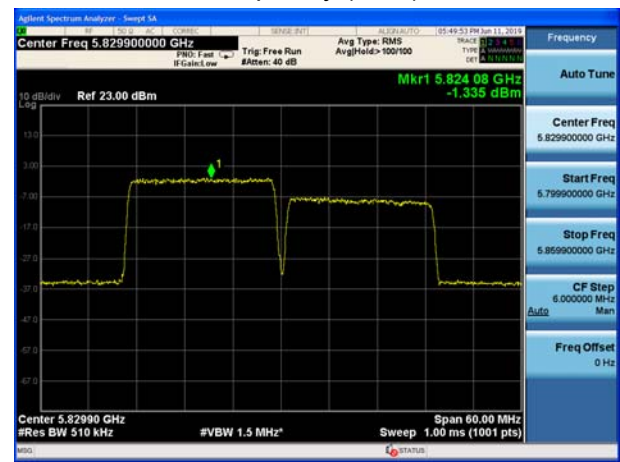

## 5.5. Unwanted Emission

### Ambient condition

Temperature	Relative humidity	Pressure
23°C ~25°C	45%~50%	101.5kPa

### Method of Measurement

The test set-up was made in accordance to the general provisions of ANSI C63.10-2013. The Equipment Under Test (EUT) was set up on a non-conductive table in the semi-anechoic chamber. The test was performed at the distance of 3 m between the EUT and the receiving antenna. The radiated emissions measurements were made in a typical installation configuration.

Sweep the whole frequency band range from 9kHz to the 10th harmonic of the carrier, and the emissions less than 20 dB below the permissible value are reported.

During the test, the height of receive antenna shall be moved from 1 to 4 meters, and the antenna shall be performed under horizontal and vertical polarization. The turntable shall be rotated from 0 to 360 degrees for detecting the maximum of radiated spurious signal level. The measurements shall be repeated with orthogonal polarization of the test antenna. The data of cable loss and antenna factor has been calibrated in full testing frequency range before the testing.

Set the spectrum analyzer in the following:

Below 1GHz (detector: Peak and Quasi-Peak)

RBW=100kHz / VBW=300kHz / Sweep=AUTO

Above 1GHz (detector: Peak):

I) Peak emission levels are measured by setting the instrument as follows:

1) RBW = 1 MHz.

2) VBW  $\geq$  [3  $\times$  RBW]

3) Detector = peak.

4) Sweep time = auto.

5) Trace mode = max hold.

6) Allow sweeps to continue until the trace stabilizes. Note that if the transmission is not continuous, then the time required for the trace to stabilize will increase by a factor of approximately 1 / D, where D is the duty cycle.

II) Average emission levels are measured by setting the instrument as follows:

a) RBW = 1 MHz.

b) VBW  $\geq$  [3  $\times$  RBW].

c) Detector = RMS (power averaging), if [span / (# of points in sweep)]  $\leq$  RBW / 2. Satisfying this condition can require increasing the number of points in the sweep or reducing the span. If the condition is not satisfied, then the detector mode shall be set to peak.

d) Averaging type = power (i.e., rms) (As an alternative, the detector and averaging type may be set for linear voltage averaging. Some instruments require linear display mode to use linear voltage averaging. Log or dB averaging shall not be used.)



e) Sweep time = auto.

f) Perform a trace average of at least 100 traces if the transmission is continuous. If the transmission is not continuous, then the number of traces shall be increased by a factor of  $1 / D$ , where  $D$  is the duty cycle. For example, with 50% duty cycle, at least 200 traces shall be averaged. (If a specific emission is demonstrated to be continuous—i.e., 100% duty cycle—then rather than turning ON and OFF with the transmit cycle, at least 100 traces shall be averaged.)

g) If tests are performed with the EUT transmitting at a duty cycle less than 98%, then a correction factor shall be added to the measurement results prior to comparing with the emission limit, to compute the emission level that would have been measured had the test been performed at 100% duty cycle. The correction factor is computed as follows:

1) If power averaging (rms) mode was used in the preceding step e), then the correction factor is  $[10 \log (1 / D)]$ , where  $D$  is the duty cycle. For example, if the transmit duty cycle was 50%, then 3 dB shall be added to the measured emission levels.

2) If linear voltage averaging mode was used in the preceding step e), then the correction factor is  $[20 \log (1 / D)]$ , where  $D$  is the duty cycle. For example, if the transmit duty cycle was 50%, then 6 dB shall be added to the measured emission levels.

3) If a specific emission is demonstrated to be continuous (100% duty cycle) rather than turning ON and OFF with the transmit cycle, then no duty cycle correction is required for that emission.

Reduce the video bandwidth until no significant variations in the displayed signal are observed in subsequent traces, provided the video bandwidth is no less than 1 Hz. For regulatory requirements that specify averaging only over the transmit duration (e.g., digital transmission system [DTS] and Unlicensed National Information Infrastructure [U-NII]), the video bandwidth shall be greater than  $[1 / (\text{minimum transmitter on time})]$  and no less than 1 Hz.

The field strength of spurious emission was measured in the following position: EUT stand-up position (Z axis), lie-down position (X, Y axis). The worst emission was found in stand-up position (Z axis) and the loop antenna is vertical, others antenna are vertical and horizontal.

The test is in transmitting mode.



9KHz~~~30MHz

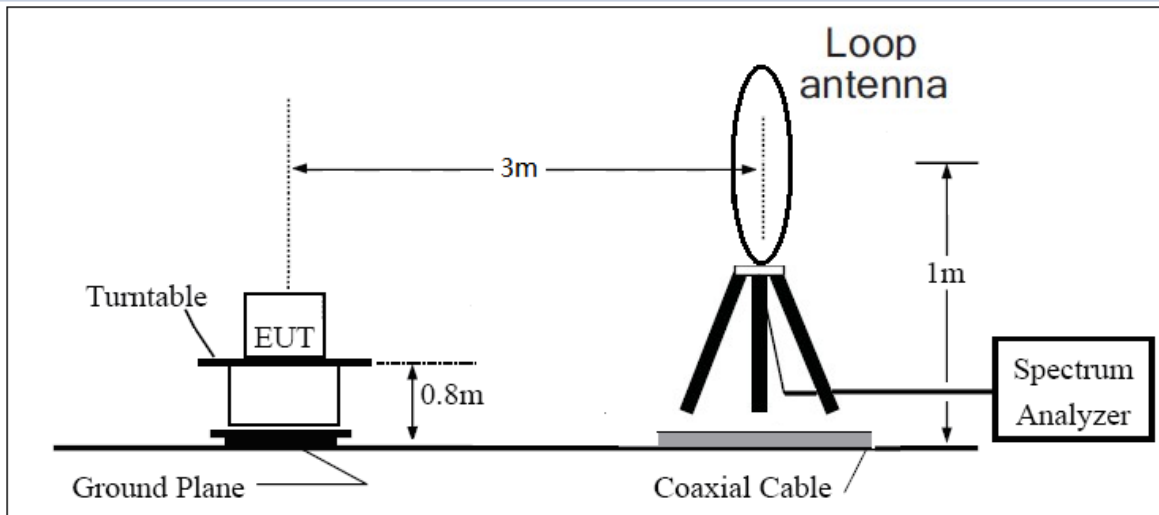

30MHz~~~ 1GHz

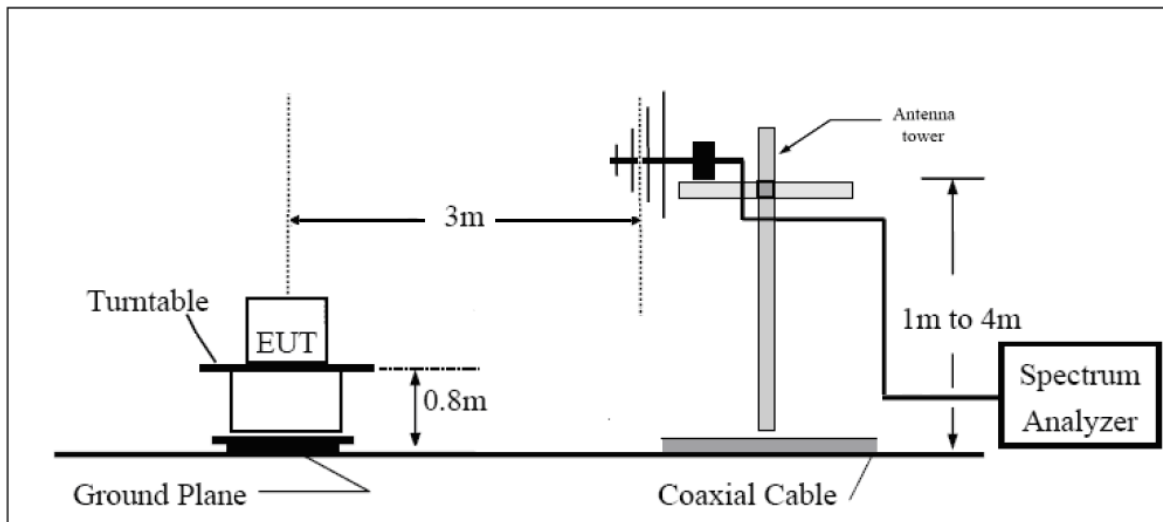

Above 1GHz

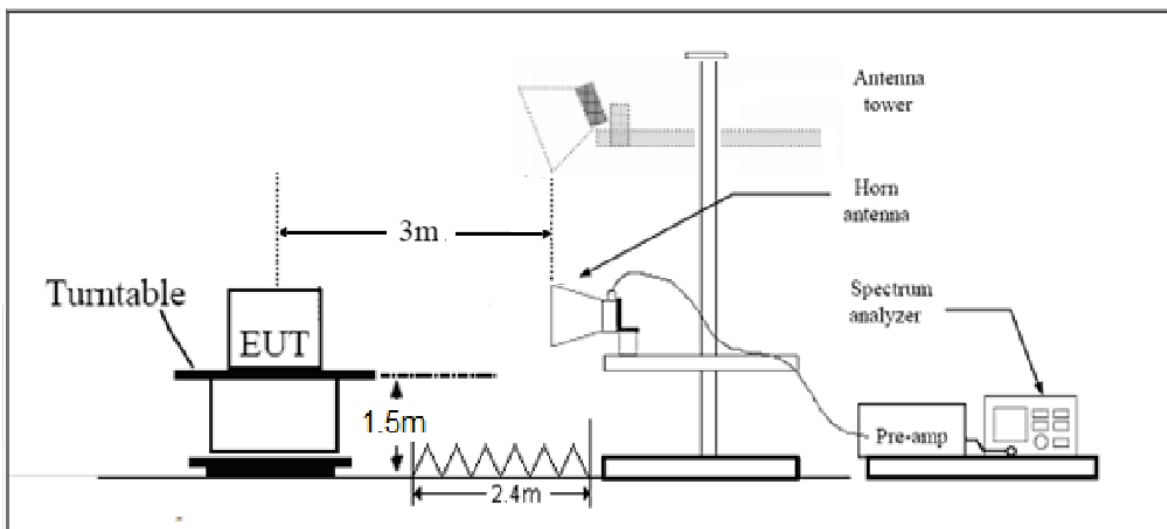

Note: Area side:2.4mX3.6m

## Limits

FCC §407 (b) Undesirable emission limits. Except as shown in paragraph (b)(7) of this section, the maximum emissions outside of the frequency bands of operation shall be attenuated in accordance with the following limits:

For transmitters operating in the 5725-5850 MHz band: All emissions shall be limited to a level of -27 dBm/MHz at 75 MHz or more above or below the band edge increasing linearly to 10 dBm/MHz at 25 MHz above or below the band edge, and from 25 MHz above or below the band edge increasing linearly to a level of 15.6 dBm/MHz at 5 MHz above or below the band edge, and from 5 MHz above or below the band edge increasing linearly to a level of 27 dBm/MHz at the band edge.

Note: the following formula is used to convert the EIRP to field strength

§1、  $E[\text{dB}\mu\text{V}/\text{m}] = \text{EIRP}[\text{dBm}] - 20 \log(d[\text{meters}]) + 104.77$ , where E = field strength and

d = distance at which field strength limit is specified in the rules;

§2、  $E[\text{dB}\mu\text{V}/\text{m}] = \text{EIRP}[\text{dBm}] + 95.2$ , for d = 3 meters

(1) Unwanted spurious emissions fallen in restricted bands per FCC Part15.205 shall comply with the general field strength limits set forth in § 15.209 as below table.

Frequency of emission (MHz)	Field strength(uV/m)	Field strength(dBuV/m)
0.009–0.490	2400/F(kHz)	/
0.490–1.705	24000/F(kHz)	/
1.705–30.0	30	/
30-88	100	40
88-216	150	43.5
216-960	200	46
Above960	500	54

MHz	MHz	MHz	GHz
0.090 - 0.110	16.42 - 16.423	399.9 - 410	4.5 - 5.15
0.495 - 0.505	16.69475 - 16.69525	608 - 614	5.35 - 5.46
2.1735 - 2.1905	16.80425 - 16.80475	960 - 1240	7.25 - 7.75
4.125 - 4.128	25.5 - 25.67	1300 - 1427	8.025 - 8.5
4.17725 - 4.17775	37.5 - 38.25	1435 - 1626.5	9.0 - 9.2
4.20725 - 4.20775	73 - 74.6	1645.5 - 1646.5	9.3 - 9.5
6.215 - 6.218	74.8 - 75.2	1660 - 1710	10.6 - 12.7
6.26775 - 6.26825	108 - 121.94	1718.8 - 1722.2	13.25 - 13.4
6.31175 - 6.31225	123 - 138	2200 - 2300	14.47 - 14.5
8.291 - 8.294	149.9 - 150.05	2310 - 2390	15.35 - 16.2
8.362 - 8.366	156.52475 - 156.52525	2483.5 - 2500	17.7 - 21.4
8.37625 - 8.38675	156.7 - 156.9	2690 - 2900	22.01 - 23.12
8.41425 - 8.41475	162.0125 - 167.17	3260 - 3267	23.6 - 24.0
12.29 - 12.293	167.72 - 173.2	3332 - 3339	31.2 - 31.8
12.51975 - 12.52025	240 - 285	3345.8 - 3358	36.43 - 36.5
12.57675 - 12.57725	322 - 335.4	3600 - 4400	( <sup>2</sup> )
13.36 - 13.41			

**Measurement Uncertainty**

The assessed measurement uncertainty to ensure 95% confidence level for the normal distribution is with the coverage factor  $k = 1.96$ .

Frequency	Uncertainty
9KHz-30MHz	3.55 dB
30MHz-200MHz	4.02 dB
200MHz-1GHz	3.28 dB
1GHz-18G	3.70 dB
18GHz-26.5GHz	5.78 dB
26.5G-40GHz	5.82 dB



**Test Results:**

**The signal beyond the limit is carrier.**

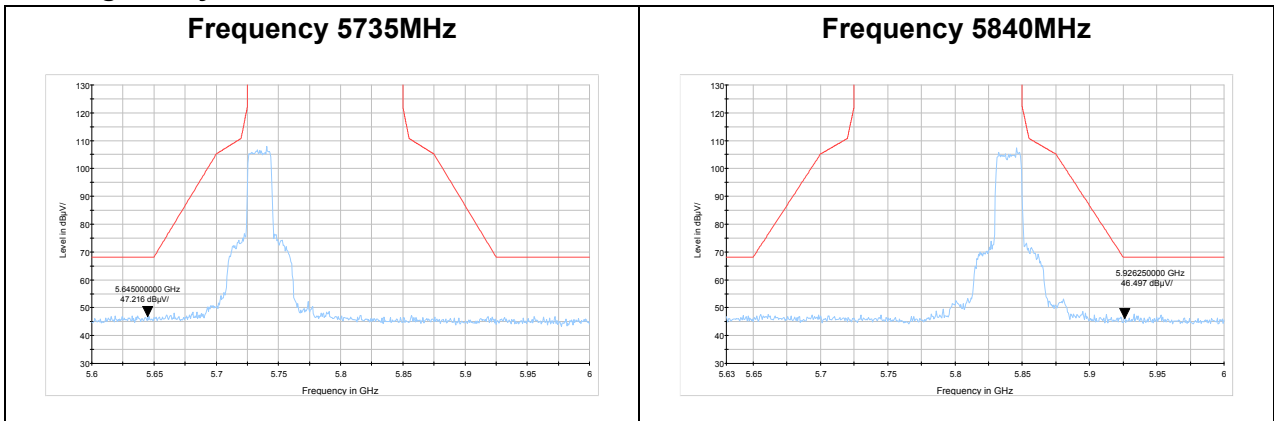



**Result of RE**

**Test result**

Sweep the whole frequency band through the range from 9kHz to the 10th harmonic of the carrier, the Emissions in the frequency band 9kHz-30MHz are more than 20dB below the limit are not reported.

**Continuous TX mode:**

**5735MHz**

FCC RE 0.03-1GHz QP Class B

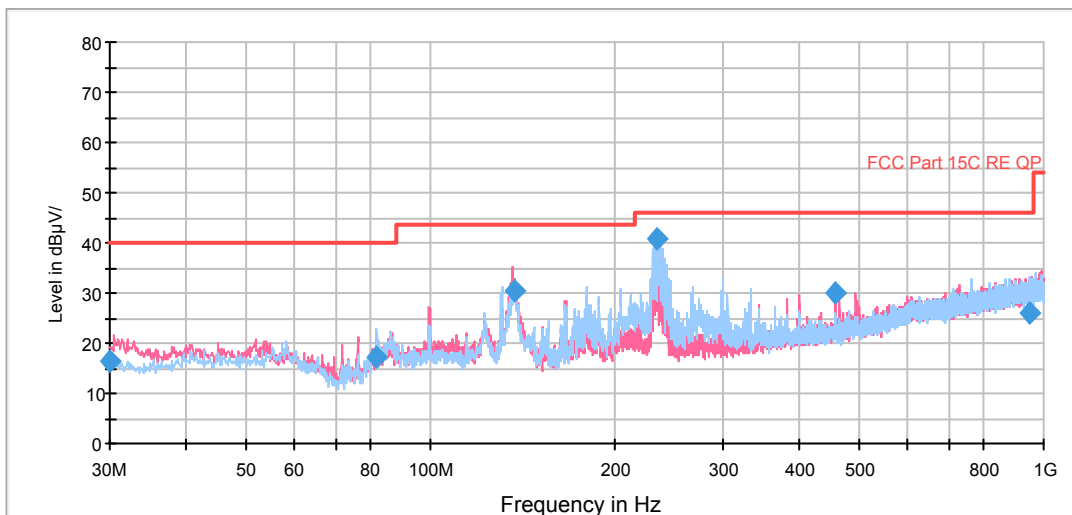

Radiates Emission from 30MHz to 1GHz

Frequency (MHz)	Quasi-Peak (dBµV/m)	Height (cm)	Polarization	Azimuth (deg)	Reading value (dBµV/m)	Correct Factor (dB)	Margin (dB)	Limit (dBµV/m)
30.080000	16.6	100.0	V	213.0	4.5	12.1	23.4	40.0
81.652500	17.1	114.0	H	0.0	7.9	9.2	22.9	40.0
136.693750	30.3	100.0	V	43.0	21.2	9.1	13.2	43.5
234.588750	40.8	114.0	H	242.0	27.3	13.5	5.2	46.0
458.168750	30.0	100.0	V	195.0	11.0	19.0	16.0	46.0
947.422500	26.0	100.0	H	22.0	-1.2	27.2	20.0	46.0

- Remark:**
1. Quasi-Peak = Reading value + Correction factor
  2. Correction Factor = Antenna factor+ Insertion loss(cable loss+amplifier gain)
  3. Margin = Limit – Quasi-Peak

RE 1G-3GHz PK+AV

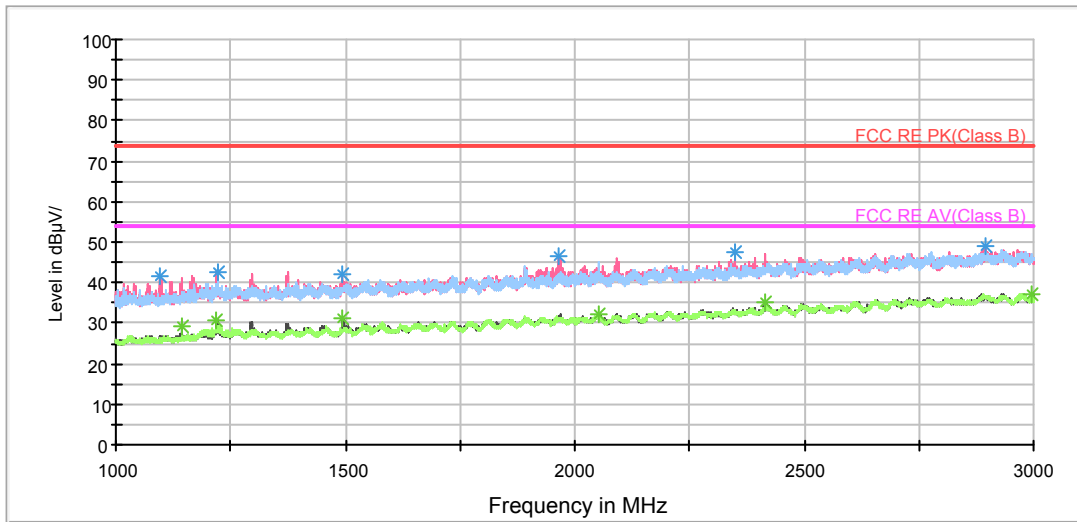

Radiates Emission from 1GHz to 3GHz

Frequency (MHz)	Peak (dBuV/m)	Height (cm)	Polarization	Azimuth (deg)	Reading value (dBuV/m)	Correct Factor (dB)	Margin (dB)	Limit (dBuV/m)
1096.750000	41.7	100.0	V	241.0	50.6	-8.9	32.3	74
1222.250000	42.6	100.0	V	231.0	50.4	-7.8	31.4	74
1493.500000	42.1	100.0	V	169.0	48.8	-6.7	31.9	74
1964.750000	46.4	100.0	V	231.0	49.7	-3.3	27.6	74
2350.500000	47.6	100.0	V	214.0	48.9	-1.3	26.4	74
2893.750000	48.8	100.0	V	143.0	46.7	2.1	25.2	74

Remark: 1. Correction Factor = Antenna factor+ Insertion loss (cable loss + amplifier gain)

Frequency (MHz)	Average (dBuV/m)	Height (cm)	Polarization	Azimuth (deg)	Reading value (dBuV/m)	Correct Factor (dB)	Margin (dB)	Limit (dBuV/m)
1144.750000	29.4	100.0	V	231.0	37.9	-8.5	24.6	54
1220.250000	30.9	100.0	V	222.0	38.8	-7.9	23.1	54
1494.250000	31.0	100.0	V	134.0	37.7	-6.7	23.0	54
2052.250000	32.1	100.0	V	187.0	35.3	-3.2	21.9	54
2413.000000	35.2	100.0	H	68.0	35.7	-0.5	18.8	54
2997.500000	37.3	100.0	V	196.0	35.0	2.3	16.7	54

Remark: 1. Correction Factor = Antenna factor+ Insertion loss (cable loss + amplifier gain)

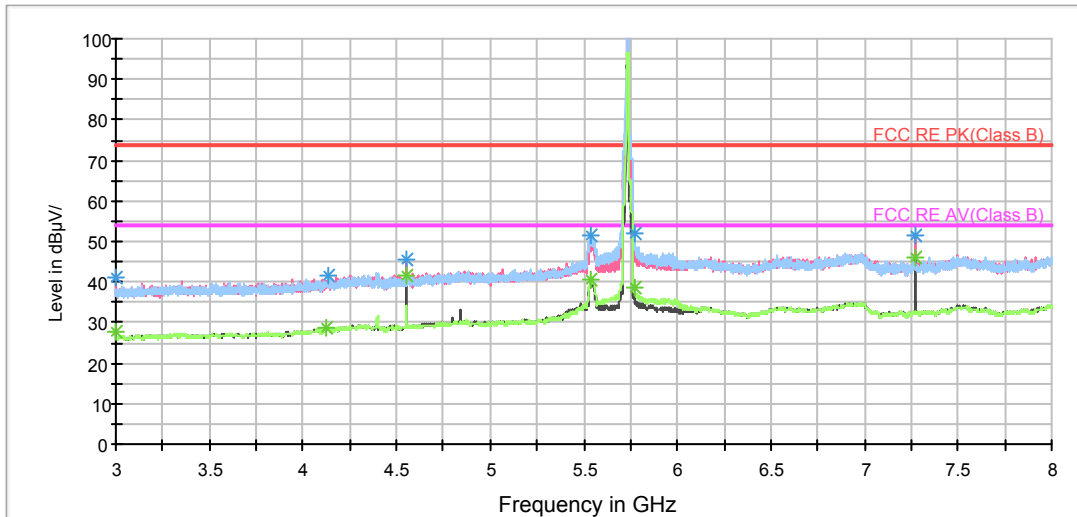

Note: The signal beyond the limit is carrier.  
Radiates Emission from 3GHz to 8GHz

Frequency (MHz)	Peak (dBuV/m)	Height (cm)	Polarization	Azimuth (deg)	Reading value (dBuV/m)	Correct Factor (dB)	Margin (dB)	Limit (dBuV/m)
3000.000000	41.0	205.0	V	261.0	44.2	-3.2	33.0	74
4136.250000	41.8	300.0	H	0.0	42.1	-0.3	32.2	74
4550.000000	45.6	205.0	V	63.0	44.8	0.8	28.4	74
5532.500000	51.5	105.0	H	0.0	48.3	3.2	22.5	74
5773.750000	52.1	205.0	H	47.0	48.3	3.8	21.9	74
7270.625000	51.7	105.0	V	178.0	44.7	7.0	22.3	74

Remark: 1. Correction Factor = Antenna factor+ Insertion loss (cable loss + amplifier gain)

Frequency (MHz)	Average (dBuV/m)	Height (cm)	Polarization	Azimuth (deg)	Reading value (dBuV/m)	Correct Factor (dB)	Margin (dB)	Limit (dBuV/m)
3000.000000	27.6	205.0	V	261.0	30.8	-3.2	26.4	54
4129.375000	28.7	205.0	H	250.0	29.1	-0.4	25.3	54
4550.000000	41.5	205.0	V	63.0	40.7	0.8	12.5	54
5542.500000	40.7	300.0	V	100.0	37.5	3.2	13.3	54
5769.375000	38.5	205.0	H	47.0	34.8	3.7	15.5	54
7271.250000	46.0	105.0	V	178.0	39.0	7.0	8.0	54

Remark: 1. Correction Factor = Antenna factor+ Insertion loss (cable loss + amplifier gain)

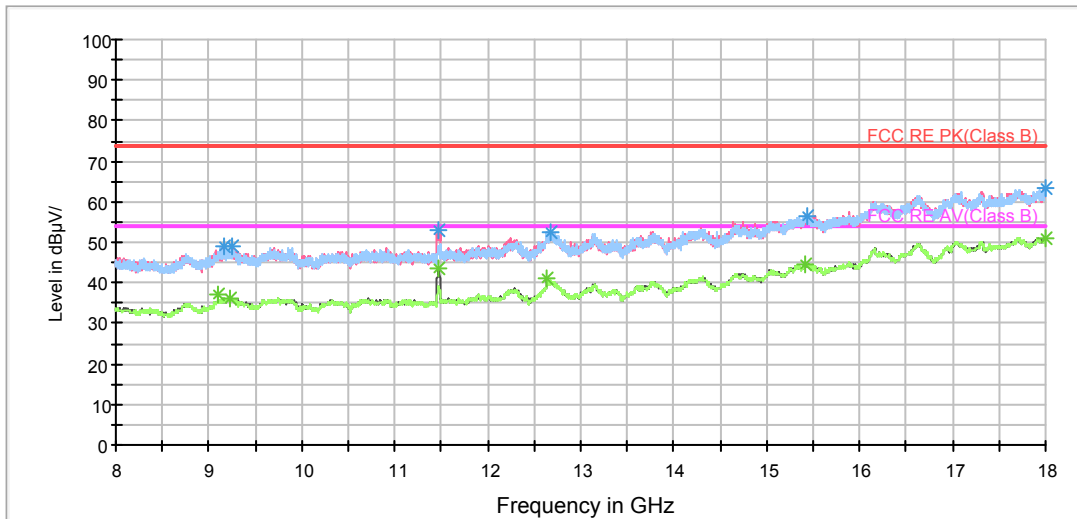

Radiates Emission from 8GHz to 18GHz

Frequency (MHz)	Peak (dBuV/m)	Height (cm)	Polarization	Azimuth (deg)	Reading value (dBuV/m)	Correct Factor (dB)	Margin (dB)	Limit (dBuV/m)
9153.750000	48.8	300.0	V	324.0	38.6	10.2	25.2	74
9260.000000	49.1	205.0	V	10.0	39.7	9.4	24.9	74
11461.250000	53.2	205.0	V	226.0	43.0	10.2	20.8	74
12686.250000	52.6	205.0	H	297.0	38.4	14.2	21.4	74
15425.000000	56.4	300.0	H	0.0	37.0	19.4	17.6	74
17998.750000	63.5	300.0	V	162.0	38.1	25.4	10.5	74

Remark: 1. Correction Factor = Antenna factor+ Insertion loss (cable loss + amplifier gain)

Frequency (MHz)	Average (dBuV/m)	Height (cm)	Polarization	Azimuth (deg)	Reading value (dBuV/m)	Correct Factor (dB)	Margin (dB)	Limit (dBuV/m)
9100.000000	37.2	205.0	V	172.0	27.7	9.5	16.8	54
9238.750000	36.3	205.0	V	118.0	26.4	9.9	17.7	54
11471.250000	43.6	205.0	V	226.0	33.4	10.2	10.4	54
12640.000000	41.0	105.0	V	0.0	26.4	14.6	13.0	54
15422.500000	44.7	300.0	V	162.0	25.3	19.4	9.3	54
17998.750000	51.2	300.0	H	339.0	25.8	25.4	2.8	54

Remark: 1. Correction Factor = Antenna factor+ Insertion loss (cable loss + amplifier gain)



RE 18-26.5GHz PK+AV

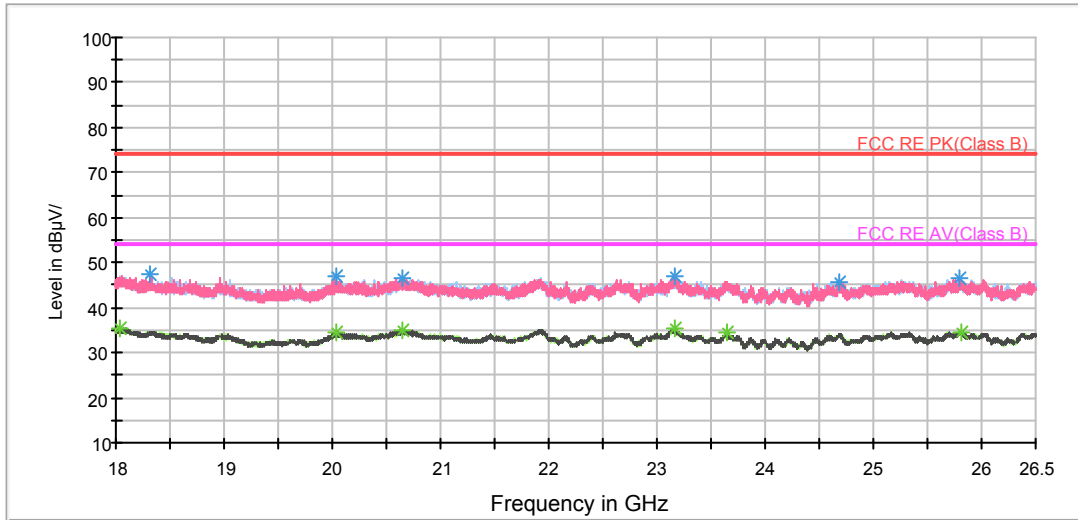

Radiates Emission from 18GHz to 26.5GHz

Frequency (MHz)	Peak (dBuV/m)	Polarization	Azimuth (deg)	Reading value (dBuV/m)	Correct Factor (dB)	Margin (dB)	Limit (dBuV/m)
18324.062500	47.5	V	15.0	50.7	-3.2	26.5	74.0
20045.312500	46.8	H	311.0	52.5	-5.7	27.2	74.0
20647.750000	46.3	V	226.0	52.9	-6.6	27.7	74.0
23160.562500	47.1	H	0.0	53.2	-6.1	26.9	74.0
24681.000000	45.8	H	0.0	51.8	-6.0	28.2	74.0
25800.875000	46.5	V	205.0	52.0	-5.5	27.5	74.0

Remark: 1. Correction Factor = Antenna factor+ Insertion loss (cable loss + amplifier gain)

Frequency (MHz)	Average (dBuV/m)	Polarization	Azimuth (deg)	Reading value (dBuV/m)	Correct Factor (dB)	Margin (dB)	Limit (dBuV/m)
18029.750000	35.3	H	129.0	37.2	-1.9	18.7	54.0
20045.312500	34.5	V	142.0	40.2	-5.7	19.5	54.0
20649.875000	35.1	V	216.0	41.7	-6.6	18.9	54.0
23160.562500	35.5	H	0.0	41.6	-6.1	18.5	54.0
23650.375000	34.3	V	153.0	40.2	-5.9	19.7	54.0
25813.625000	34.7	H	0.0	40.2	-5.5	19.3	54.0

Remark: 1. Correction Factor = Antenna factor+ Insertion loss (cable loss + amplifier gain)

RE 26.5-40GHz PK+AV

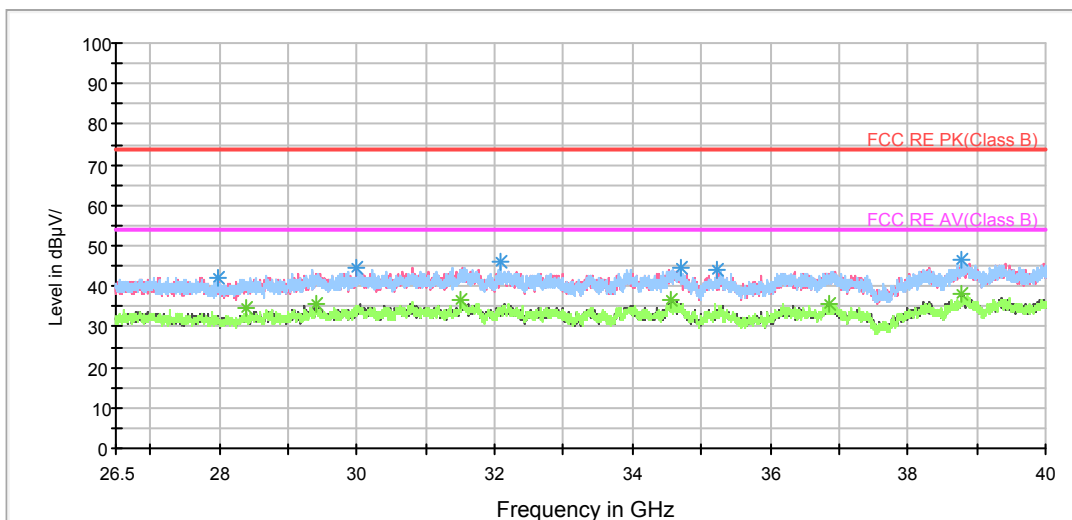

Radiates Emission from 26.5GHz to 40GHz

Frequency (MHz)	Peak (dBuV/m)	Polarization	Azimuth (deg)	Reading value (dBuV/m)	Correct Factor (dB)	Margin (dB)	Limit (dBuV/m)
27985.000000	42.2	V	235.0	43.9	-1.7	31.8	74.0
29988.062500	44.5	V	177.0	44.9	-0.4	29.5	74.0
32080.562500	46.3	H	19.0	46.8	-0.5	27.7	74.0
34701.250000	44.3	H	9.0	45.2	-0.9	29.7	74.0
35217.625000	43.8	V	0.0	44.4	-0.6	30.2	74.0
38779.937500	46.3	H	19.0	43.6	2.7	27.7	74.0

Remark: 1. Correction Factor = Antenna factor+ Insertion loss (cable loss + amplifier gain)

Frequency (MHz)	Average (dBuV/m)	Polarization	Azimuth (deg)	Reading value (dBuV/m)	Correct Factor (dB)	Margin (dB)	Limit (dBuV/m)
28381.562500	34.4	H	299.0	35.9	-1.5	19.6	54.0
29414.312500	35.8	H	0.0	36.7	-0.9	18.2	54.0
31516.937500	36.5	H	0.0	37.0	-0.5	17.5	54.0
34547.687500	36.8	V	137.0	37.8	-1.0	17.2	54.0
36856.187500	35.7	V	245.0	35.8	-0.1	18.3	54.0
38788.375000	37.9	V	235.0	35.2	2.7	16.1	54.0

Remark: 1. Correction Factor = Antenna factor+ Insertion loss (cable loss + amplifier gain)

5790MHz

FCC RE 0.03-1GHz QP Class B

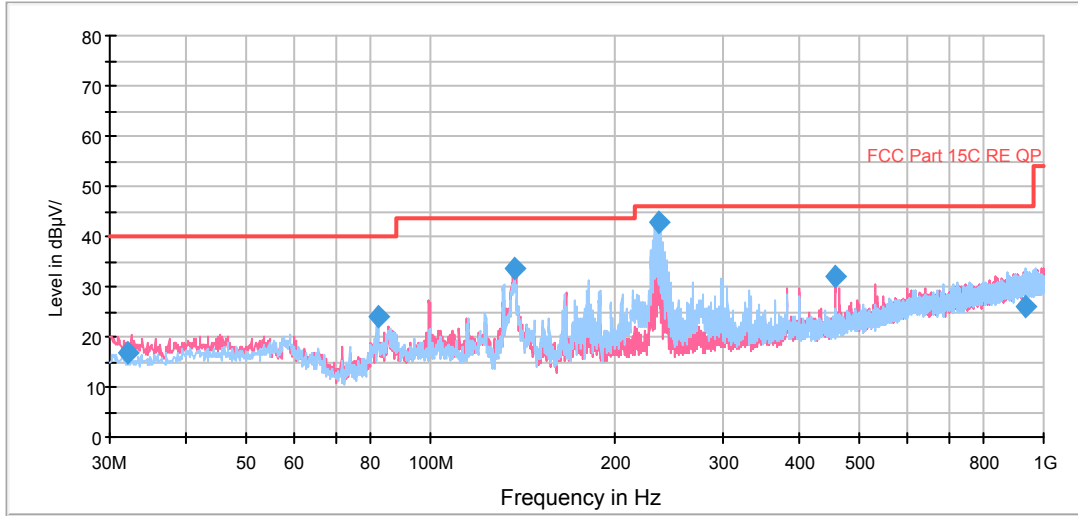

Radiates Emission from 30MHz to 1GHz

Frequency (MHz)	Quasi-Peak (dBuV/m)	Height (cm)	Polarization	Azimuth (deg)	Reading value (dBuV/m)	Correct Factor (dB)	Margin (dB)	Limit (dBuV/m)
32.146250	16.9	100.0	V	211.0	4.9	12.0	23.1	40.0
82.057500	23.8	125.0	H	327.0	14.6	9.2	16.2	40.0
136.820000	33.5	100.0	V	36.0	24.4	9.1	10.0	43.5
235.357500	42.9	125.0	H	235.0	29.1	13.8	3.1	46.0
458.376250	31.9	100.0	V	191.0	12.9	19.0	14.1	46.0
935.980000	25.9	125.0	H	188.0	-1.1	27.0	20.1	46.0

- Remark: 1. Quasi-Peak = Reading value + Correction factor  
 2. Correction Factor = Antenna factor+ Insertion loss(cable loss+amplifier gain)  
 3. Margin = Limit – Quasi-Peak

RE 1G-3GHz PK+AV

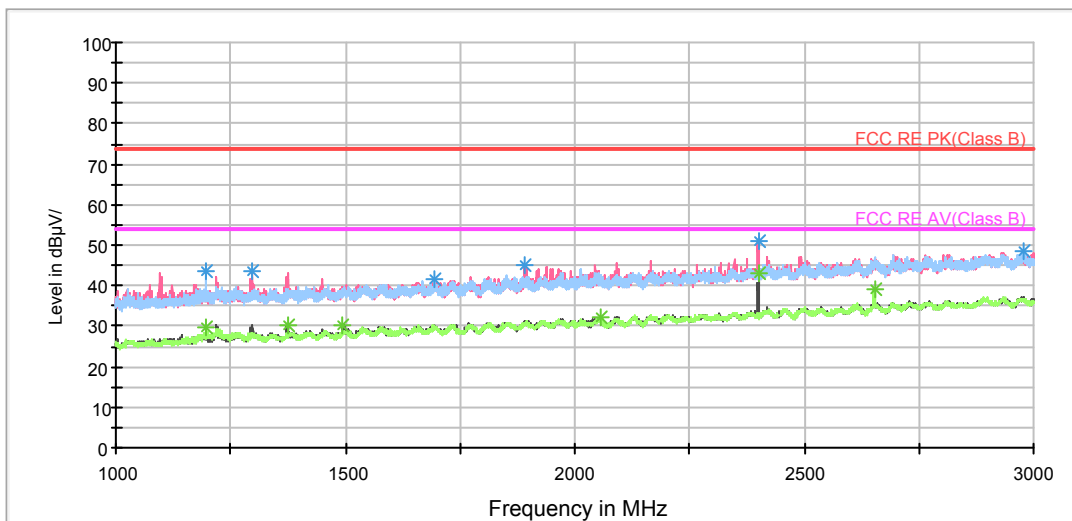

Radiates Emission from 1GHz to 3GHz

Frequency (MHz)	Peak (dBuV/m)	Height (cm)	Polarization	Azimuth (deg)	Reading value (dBuV/m)	Correct Factor (dB)	Margin (dB)	Limit (dBuV/m)
1195.750000	43.4	100.0	H	220.0	51.6	-8.2	30.6	74
1297.000000	43.8	100.0	V	187.0	51.6	-7.8	30.2	74
1693.250000	41.7	100.0	H	150.0	46.7	-5.0	32.3	74
1892.250000	45.1	100.0	V	268.0	49.3	-4.2	28.9	74
2400.500000	50.8	100.0	V	294.0	52.0	-1.2	23.2	74
2979.750000	48.4	100.0	V	354.0	46.2	2.2	25.6	74

Remark: 1. Correction Factor = Antenna factor+ Insertion loss (cable loss + amplifier gain)

Frequency (MHz)	Average (dBuV/m)	Height (cm)	Polarization	Azimuth (deg)	Reading value (dBuV/m)	Correct Factor (dB)	Margin (dB)	Limit (dBuV/m)
1195.750000	29.7	100.0	H	220.0	37.9	-8.2	24.3	54
1373.750000	30.3	100.0	V	187.0	37.4	-7.1	23.7	54
1493.750000	30.2	100.0	V	320.0	36.9	-6.7	23.8	54
2056.000000	32.0	100.0	V	170.0	35.2	-3.2	22.0	54
2400.250000	42.9	100.0	V	294.0	44.1	-1.2	11.1	54
2653.000000	39.3	100.0	H	229.0	38.9	0.4	14.7	54

Remark: 1. Correction Factor = Antenna factor+ Insertion loss (cable loss + amplifier gain)

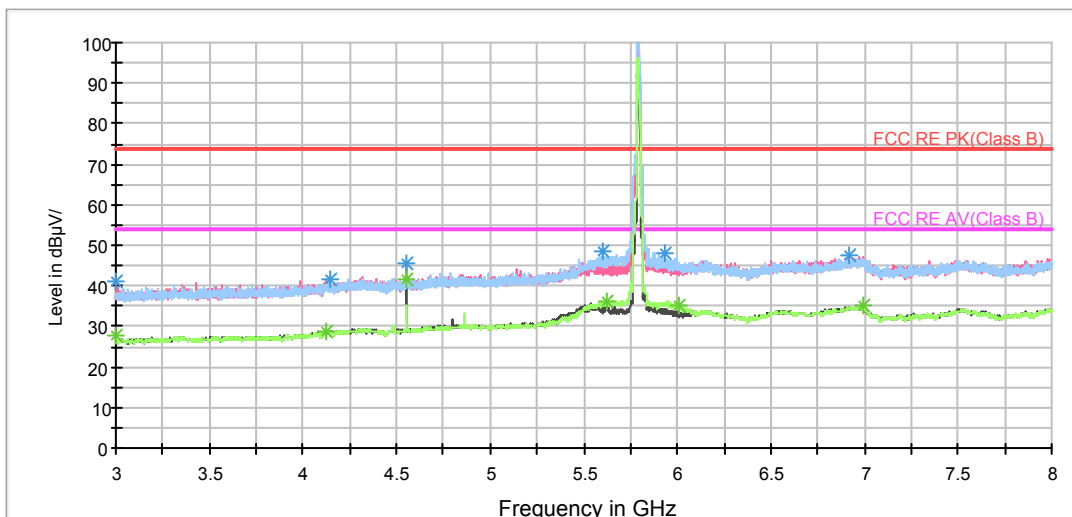

Note: The signal beyond the limit is carrier.  
Radiates Emission from 3GHz to 8GHz

Frequency (MHz)	Peak (dBuV/m)	Height (cm)	Polarization	Azimuth (deg)	Reading value (dBuV/m)	Correct Factor (dB)	Margin (dB)	Limit (dBuV/m)
3000.000000	41.3	205.0	V	262.0	44.5	-3.2	32.7	74
4143.750000	41.5	300.0	H	61.0	41.7	-0.2	32.5	74
4550.000000	45.7	205.0	V	60.0	44.9	0.8	28.3	74
5598.125000	48.7	105.0	H	0.0	45.3	3.4	25.3	74
5938.125000	48.0	105.0	H	134.0	43.2	4.8	26.0	74
6920.000000	47.3	105.0	V	348.0	41.1	6.2	26.7	74

Remark: 1. Correction Factor = Antenna factor+ Insertion loss (cable loss + amplifier gain)

Frequency (MHz)	Average (dBuV/m)	Height (cm)	Polarization	Azimuth (deg)	Reading value (dBuV/m)	Correct Factor (dB)	Margin (dB)	Limit (dBuV/m)
3000.000000	27.5	205.0	V	262.0	30.7	-3.2	26.5	54
4123.750000	28.7	300.0	V	348.0	29.1	-0.4	25.3	54
4550.000000	41.5	205.0	V	60.0	40.7	0.8	12.5	54
5626.875000	36.0	105.0	H	0.0	32.6	3.4	18.0	54
6005.625000	35.3	105.0	H	134.0	30.5	4.8	18.7	54
6996.250000	34.9	205.0	H	327.0	28.4	6.5	19.1	54

Remark: 1. Correction Factor = Antenna factor+ Insertion loss (cable loss + amplifier gain)

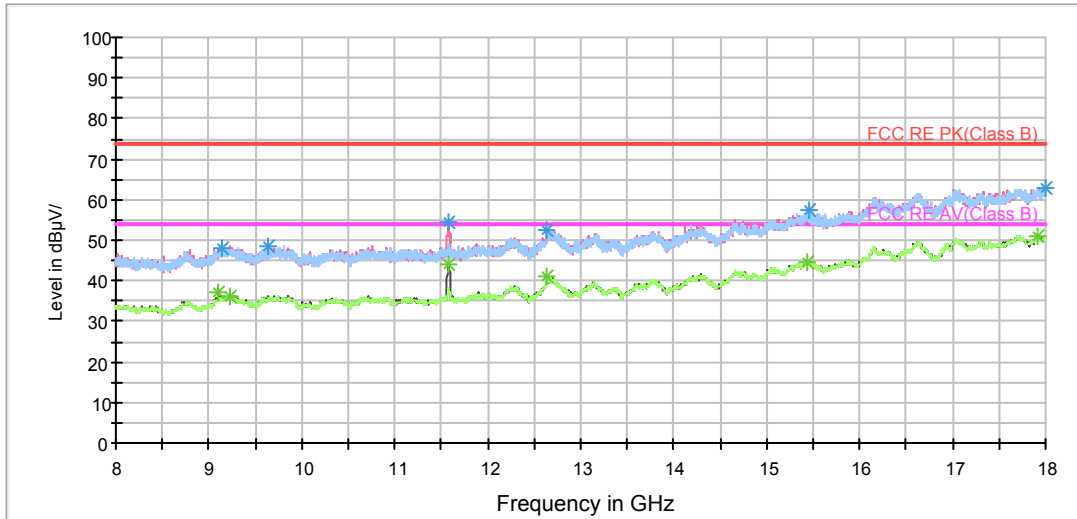

Radiates Emission from 8GHz to 18GHz

Frequency (MHz)	Peak (dBuV/m)	Height (cm)	Polarization	Azimuth (deg)	Reading value (dBuV/m)	Correct Factor (dB)	Margin (dB)	Limit (dBuV/m)
9140.000000	47.9	300.0	V	0.0	38.0	9.9	26.1	74
9633.750000	48.4	300.0	H	225.0	38.5	9.9	25.6	74
11580.000000	54.2	205.0	V	225.0	43.1	11.1	19.8	74
12635.000000	52.5	300.0	V	217.0	38.5	14.0	21.5	74
15448.750000	57.2	300.0	H	115.0	37.7	19.5	16.8	74
17997.500000	63.1	105.0	H	9.0	37.7	25.4	10.9	74

Remark: 1. Correction Factor = Antenna factor+ Insertion loss (cable loss + amplifier gain)

Frequency (MHz)	Average (dBuV/m)	Height (cm)	Polarization	Azimuth (deg)	Reading value (dBuV/m)	Correct Factor (dB)	Margin (dB)	Limit (dBuV/m)
9100.000000	37.4	105.0	V	337.0	27.9	9.5	16.6	54
9235.000000	36.4	105.0	H	89.0	26.5	9.9	17.6	54
11573.750000	43.9	205.0	V	225.0	32.9	11.0	10.1	54
12640.000000	40.9	300.0	V	163.0	26.3	14.6	13.1	54
15438.750000	44.7	105.0	H	36.0	25.2	19.5	9.3	54
17920.000000	51.1	105.0	H	0.0	25.3	25.8	2.9	54

Remark: 1. Correction Factor = Antenna factor+ Insertion loss (cable loss + amplifier gain)

RE 18-26.5GHz PK+AV

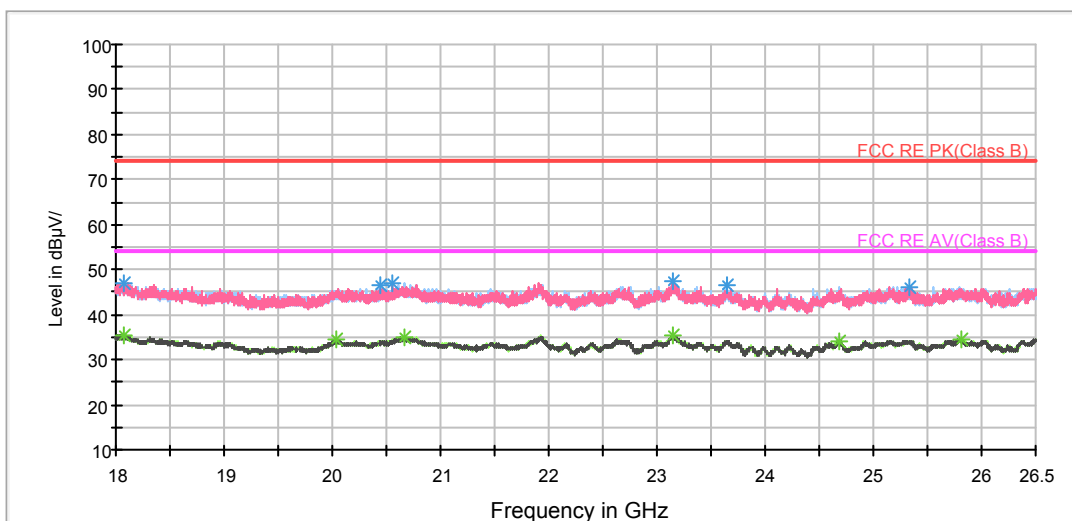

Radiates Emission from 18GHz to 26.5GHz

Frequency (MHz)	Peak (dBuV/m)	Polarization	Azimuth (deg)	Reading value (dBuV/m)	Correct Factor (dB)	Margin (dB)	Limit (dBuV/m)
18072.250000	47.1	V	111.0	49.2	-2.1	26.9	74.0
20450.125000	46.5	H	196.0	52.6	-6.1	27.5	74.0
20553.187500	46.9	V	80.0	53.2	-6.3	27.1	74.0
23139.312500	47.3	V	238.0	53.4	-6.1	26.7	74.0
23640.812500	46.3	V	111.0	52.2	-5.9	27.7	74.0
25334.437500	46.1	H	270.0	51.9	-5.8	27.9	74.0

Remark: 1. Correction Factor = Antenna factor+ Insertion loss (cable loss + amplifier gain)

Frequency (MHz)	Average (dBuV/m)	Polarization	Azimuth (deg)	Reading value (dBuV/m)	Correct Factor (dB)	Margin (dB)	Limit (dBuV/m)
18068.000000	35.4	V	80.0	37.5	-2.1	18.6	54.0
20042.125000	34.4	V	132.0	40.1	-5.7	19.6	54.0
20667.937500	34.8	V	0.0	41.4	-6.6	19.2	54.0
23151.000000	35.3	H	228.0	41.4	-6.1	18.7	54.0
24691.625000	34.2	H	0.0	40.2	-6.0	19.8	54.0
25817.875000	34.7	H	280.0	40.2	-5.5	19.3	54.0

Remark: 1. Correction Factor = Antenna factor+ Insertion loss (cable loss + amplifier gain)

RE 26.5-40GHz PK+AV

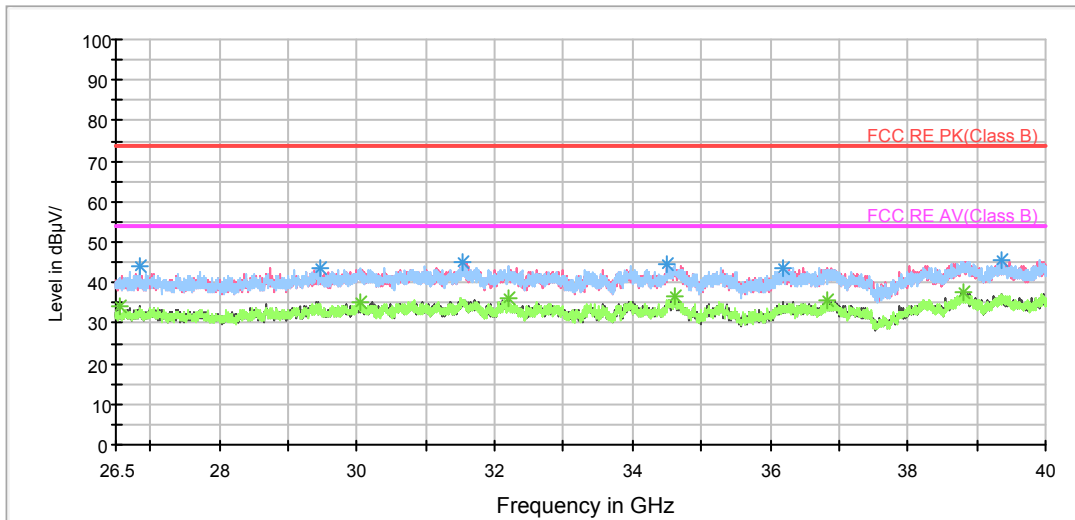

Radiates Emission from 26.5GHz to 40GHz

Frequency (MHz)	Peak (dBuV/m)	Polarization	Azimuth (deg)	Reading value (dBuV/m)	Correct Factor (dB)	Margin (dB)	Limit (dBuV/m)
26839.187500	44.0	H	227.0	44.7	-0.7	30.0	74.0
29466.625000	43.8	H	0.0	44.6	-0.8	30.2	74.0
31520.312500	45.0	V	4.0	45.5	-0.5	29.0	74.0
34513.937500	44.5	V	0.0	45.5	-1.0	29.5	74.0
36194.687500	43.5	H	207.0	43.7	-0.2	30.5	74.0
39363.812500	45.4	V	0.0	42.6	2.8	28.6	74.0

Remark: 1. Correction Factor = Antenna factor+ Insertion loss (cable loss + amplifier gain)

Frequency (MHz)	Average (dBuV/m)	Polarization	Azimuth (deg)	Reading value (dBuV/m)	Correct Factor (dB)	Margin (dB)	Limit (dBuV/m)
26570.875000	34.3	V	72.0	34.7	-0.4	19.7	54.0
30043.750000	35.3	H	76.0	35.7	-0.4	18.7	54.0
32200.375000	36.4	V	344.0	36.9	-0.5	17.6	54.0
34610.125000	36.5	H	299.0	37.5	-1.0	17.5	54.0
36819.062500	35.7	H	104.0	35.8	-0.1	18.3	54.0
38806.937500	37.6	V	327.0	34.8	2.8	16.4	54.0

Remark: 1. Correction Factor = Antenna factor+ Insertion loss (cable loss + amplifier gain)





5840MHz

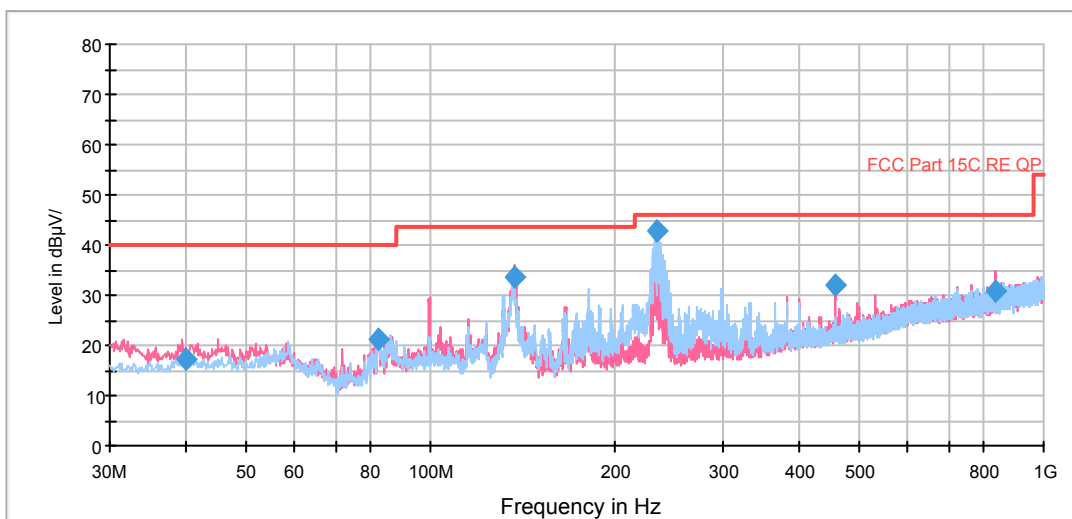

Radiates Emission from 30MHz to 1GHz

Frequency (MHz)	Quasi-Peak (dBuV/m)	Height (cm)	Polarization	Azimuth (deg)	Reading value (dBuV/m)	Correct Factor (dB)	Margin (dB)	Limit (dBuV/m)
39.857500	17.1	100.0	V	226.0	3.9	13.2	22.9	40.0
82.060000	21.1	100.0	H	330.0	11.9	9.2	18.9	40.0
136.821250	33.5	100.0	V	37.0	24.4	9.1	10.0	43.5
233.816250	42.8	125.0	H	235.0	29.0	13.8	3.2	46.0
458.372500	32.0	100.0	V	198.0	13.0	19.0	14.0	46.0
837.122500	30.6	125.0	V	169.0	4.8	25.8	15.4	46.0

- Remark: 1. Quasi-Peak = Reading value + Correction factor  
 2. Correction Factor = Antenna factor+ Insertion loss(cable loss+amplifier gain)  
 3. Margin = Limit – Quasi-Peak

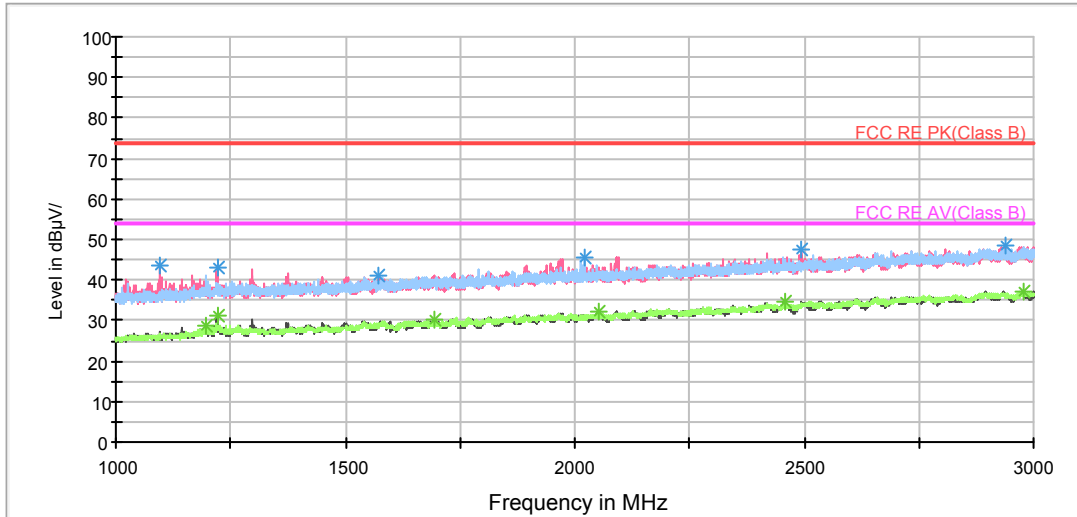

Radiates Emission from 1GHz to 3GHz

Frequency (MHz)	Peak (dBuV/m)	Height (cm)	Polarization	Azimuth (deg)	Reading value (dBuV/m)	Correct Factor (dB)	Margin (dB)	Limit (dBuV/m)
1096.750000	43.4	100.0	V	212.0	52.3	-8.9	30.6	74
1222.500000	43.2	100.0	V	229.0	51.0	-7.8	30.8	74
1574.000000	41.1	100.0	V	265.0	47.5	-6.4	32.9	74
2021.250000	45.5	100.0	H	244.0	49.1	-3.6	28.5	74
2495.500000	47.4	100.0	V	229.0	47.3	0.1	26.6	74
2937.750000	48.4	100.0	V	96.0	46.5	1.9	25.6	74

Remark: 1. Correction Factor = Antenna factor+ Insertion loss (cable loss + amplifier gain)

Frequency (MHz)	Average (dBuV/m)	Height (cm)	Polarization	Azimuth (deg)	Reading value (dBuV/m)	Correct Factor (dB)	Margin (dB)	Limit (dBuV/m)
1196.500000	28.8	100.0	H	222.0	37.0	-8.2	25.2	54
1221.500000	31.3	100.0	V	229.0	39.1	-7.8	22.7	54
1696.000000	30.1	100.0	V	247.0	35.1	-5.0	23.9	54
2052.750000	32.0	100.0	V	229.0	35.2	-3.2	22.0	54
2457.000000	34.5	100.0	V	335.0	35.0	-0.5	19.5	54
2980.000000	37.1	100.0	V	0.0	34.9	2.2	16.9	54

Remark: 1. Correction Factor = Antenna factor+ Insertion loss (cable loss + amplifier gain)

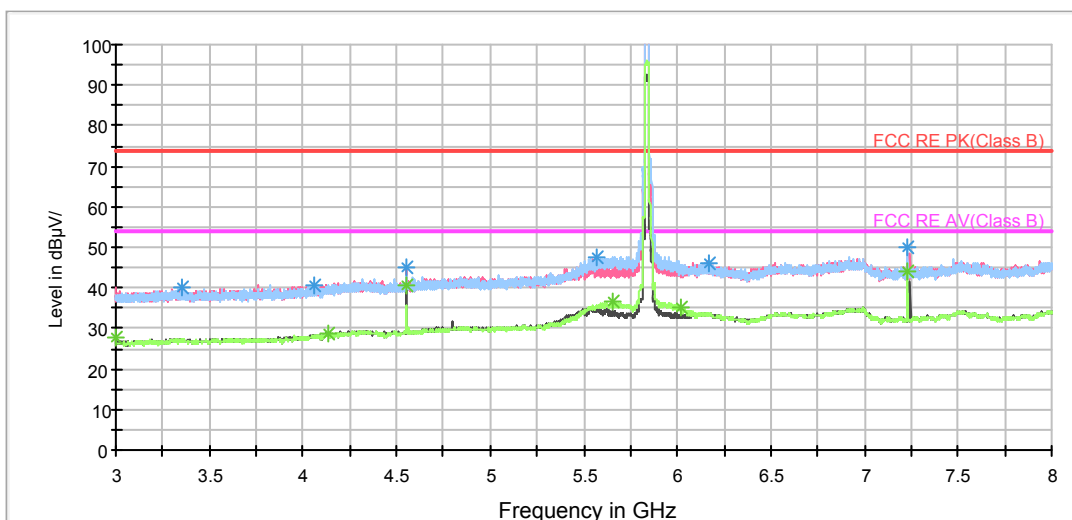

Note: The signal beyond the limit is carrier.  
Radiates Emission from 3GHz to 8GHz

Frequency (MHz)	Peak (dBuV/m)	Height (cm)	Polarization	Azimuth (deg)	Reading value (dBuV/m)	Correct Factor (dB)	Margin (dB)	Limit (dBuV/m)
3357.500000	40.2	105.0	H	0.0	42.5	-2.3	33.8	74
4057.500000	40.8	205.0	H	331.0	41.9	-1.1	33.2	74
4549.375000	45.0	205.0	V	58.0	44.2	0.8	29.0	74
5565.625000	47.7	105.0	H	0.0	44.4	3.3	26.3	74
6166.875000	45.8	300.0	H	0.0	40.2	5.6	28.2	74
7233.125000	50.0	205.0	H	206.0	43.2	6.8	24.0	74

Remark: 1. Correction Factor = Antenna factor+ Insertion loss (cable loss + amplifier gain)

Frequency (MHz)	Average (dBuV/m)	Height (cm)	Polarization	Azimuth (deg)	Reading value (dBuV/m)	Correct Factor (dB)	Margin (dB)	Limit (dBuV/m)
3000.000000	27.7	205.0	V	261.0	30.9	-3.2	26.3	54
4136.250000	28.7	105.0	H	61.0	29.0	-0.3	25.3	54
4550.000000	40.8	205.0	V	58.0	40.0	0.8	13.2	54
5658.750000	36.6	105.0	H	0.0	33.1	3.5	17.4	54
6018.125000	35.0	105.0	H	135.0	30.3	4.7	19.0	54
7233.125000	44.3	205.0	H	206.0	37.5	6.8	9.7	54

Remark: 1. Correction Factor = Antenna factor+ Insertion loss (cable loss + amplifier gain)

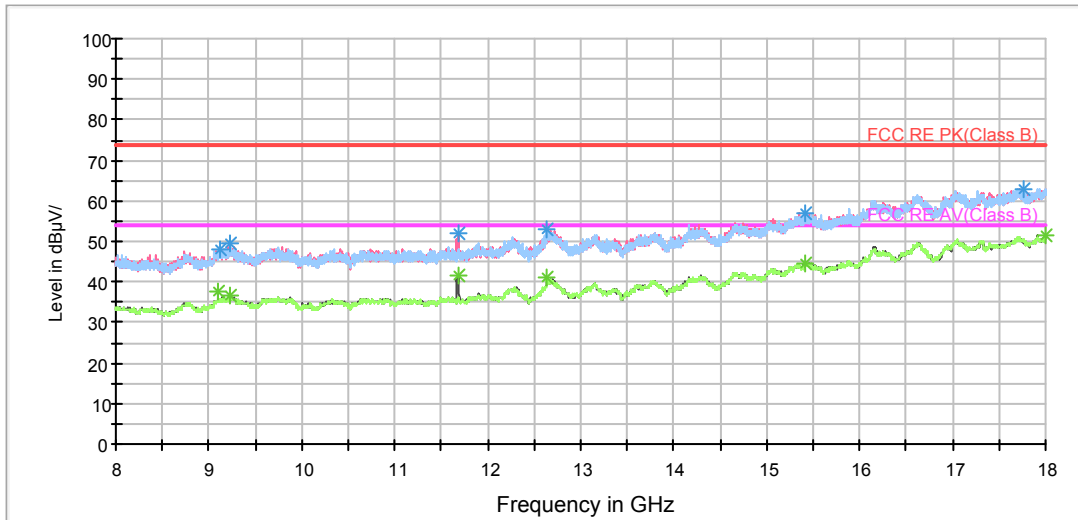

Radiates Emission from 8GHz to 18GHz

Frequency (MHz)	Peak (dBuV/m)	Height (cm)	Polarization	Azimuth (deg)	Reading value (dBuV/m)	Correct Factor (dB)	Margin (dB)	Limit (dBuV/m)
9130.000000	47.9	300.0	V	330.0	37.9	10.0	26.1	74
9238.750000	49.6	300.0	H	254.0	39.7	9.9	24.4	74
11676.250000	51.8	205.0	V	224.0	40.4	11.4	22.2	74
12638.750000	53.0	300.0	H	91.0	38.6	14.4	21.0	74
15420.000000	57.1	205.0	H	0.0	37.7	19.4	16.9	74
17753.750000	63.1	205.0	V	252.0	38.9	24.2	10.9	74

Remark: 1. Correction Factor = Antenna factor+ Insertion loss (cable loss + amplifier gain)

Frequency (MHz)	Average (dBuV/m)	Height (cm)	Polarization	Azimuth (deg)	Reading value (dBuV/m)	Correct Factor (dB)	Margin (dB)	Limit (dBuV/m)
9100.000000	37.5	205.0	V	90.0	28.0	9.5	16.5	54
9218.750000	36.4	105.0	V	0.0	26.5	9.9	17.6	54
11681.250000	41.3	205.0	V	224.0	29.9	11.4	12.7	54
12640.000000	40.9	205.0	V	0.0	26.3	14.6	13.1	54
15422.500000	44.7	300.0	V	0.0	25.3	19.4	9.3	54
17998.750000	51.3	300.0	V	249.0	25.9	25.4	2.7	54

Remark: 1. Correction Factor = Antenna factor+ Insertion loss (cable loss + amplifier gain)

RE 18-26.5GHz PK+AV

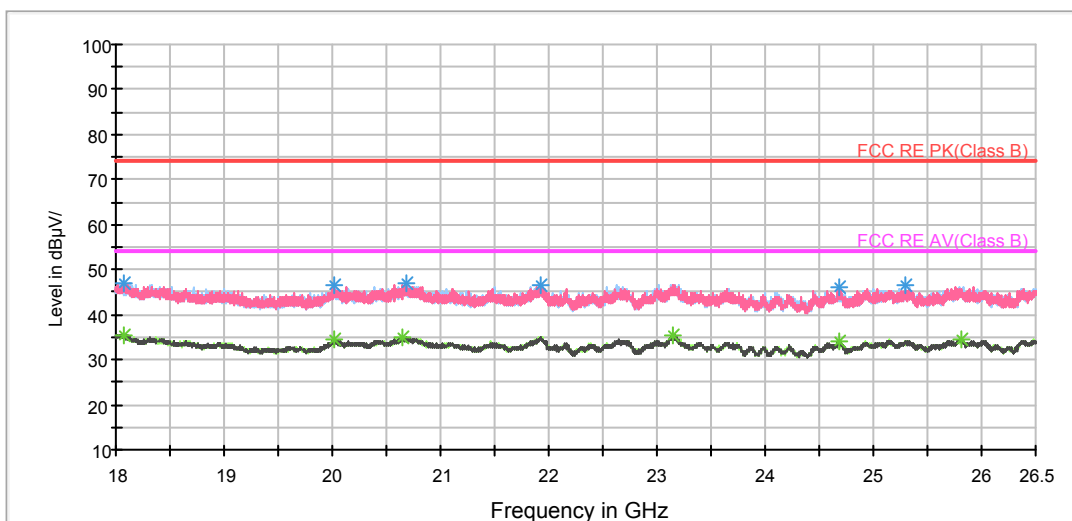

Radiates Emission from 18GHz to 26.5GHz

Frequency (MHz)	Peak (dBuV/m)	Polarization	Azimuth (deg)	Reading value (dBuV/m)	Correct Factor (dB)	Margin (dB)	Limit (dBuV/m)
18079.687500	46.9	V	185.0	49.0	-2.1	27.1	74.0
20025.125000	46.3	V	68.0	52.0	-5.7	27.7	74.0
20683.875000	47.1	V	0.0	53.7	-6.6	26.9	74.0
21918.500000	46.7	V	15.0	54.7	-8.0	27.3	74.0
24692.687500	46.1	V	68.0	52.1	-6.0	27.9	74.0
25300.437500	46.6	H	302.0	52.4	-5.8	27.4	74.0

Remark: 1. Correction Factor = Antenna factor+ Insertion loss (cable loss + amplifier gain)

Frequency (MHz)	Average (dBuV/m)	Polarization	Azimuth (deg)	Reading value (dBuV/m)	Correct Factor (dB)	Margin (dB)	Limit (dBuV/m)
18069.062500	35.6	H	79.0	37.7	-2.1	18.4	54.0
20027.250000	34.4	H	334.0	40.1	-5.7	19.6	54.0
20652.000000	35.0	V	306.0	41.6	-6.6	19.0	54.0
23153.125000	35.5	H	0.0	41.6	-6.1	18.5	54.0
24683.125000	33.9	H	112.0	39.9	-6.0	20.1	54.0
25808.312500	34.5	V	26.0	40.0	-5.5	19.5	54.0

Remark: 1. Correction Factor = Antenna factor+ Insertion loss (cable loss + amplifier gain)

RE 26.5-40GHz PK+AV

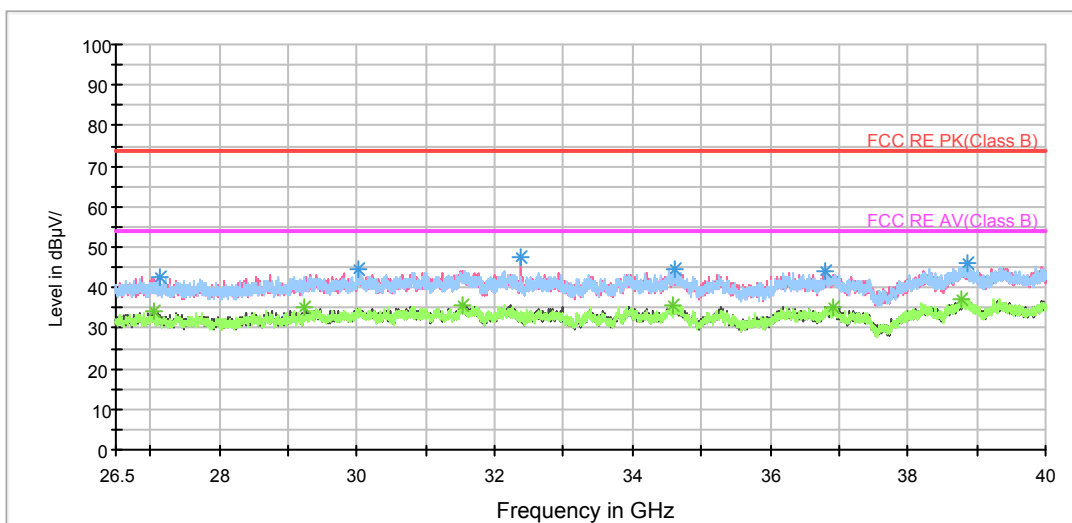

Radiates Emission from 26.5GHz to 40GHz

Frequency (MHz)	Peak (dBuV/m)	Polarization	Azimuth (deg)	Reading value (dBuV/m)	Correct Factor (dB)	Margin (dB)	Limit (dBuV/m)
27132.812500	42.8	V	0.0	43.8	-1.0	31.2	74.0
30023.500000	44.5	H	49.0	44.9	-0.4	29.5	74.0
32367.437500	47.4	V	314.0	48.0	-0.6	26.6	74.0
34611.812500	44.6	H	0.0	45.6	-1.0	29.4	74.0
36808.937500	43.8	H	58.0	43.9	-0.1	30.2	74.0
38877.812500	46.0	H	171.0	43.1	2.9	28.0	74.0

Remark: 1. Correction Factor = Antenna factor+ Insertion loss (cable loss + amplifier gain)

Frequency (MHz)	Average (dBuV/m)	Polarization	Azimuth (deg)	Reading value (dBuV/m)	Correct Factor (dB)	Margin (dB)	Limit (dBuV/m)
27051.812500	34.3	V	265.0	35.3	-1.0	19.7	54.0
29238.812500	35.1	V	209.0	36.1	-1.0	18.9	54.0
31545.625000	35.9	H	105.0	36.4	-0.5	18.1	54.0
34601.687500	35.7	V	286.0	36.7	-1.0	18.3	54.0
36920.312500	35.2	V	170.0	35.3	-0.1	18.8	54.0
38786.687500	37.3	V	189.0	34.6	2.7	16.7	54.0

Remark: 1. Correction Factor = Antenna factor+ Insertion loss (cable loss + amplifier gain)

## 5.6. Conducted spurious emissions at antenna port

### Ambient condition

Temperature	Relative humidity	Pressure
23°C ~25°C	45%~50%	101.5kPa

### Methods of Measurement

The EUT was connected to the spectrum analyzer through an external attenuator (20dB) and a known loss cable. Set RBW = 1MHz, VBW =3MHz for the9kHz to 10th harmonic

The conducted is measured at each antenna port. The measured results at the various antenna ports are then summed mathematically.

### Test Setup

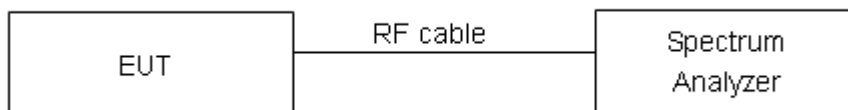

### Limits

FCC §407 (b) Undesirable emission limits. Except as shown in paragraph (b)(7) of this section, the maximum emissions outside of the frequency bands of operation shall be attenuated in accordance with the following limits:

(4) For transmitters operating in the 5725-5850 MHz band: All emissions shall be limited to a level of -27 dBm/MHz at 75 MHz or more above or below the band edge increasing linearly to 10 dBm/MHz at 25 MHz above or below the band edge, and from 25 MHz above or below the band edge increasing linearly to a level of 15.6 dBm/MHz at 5 MHz above or below the band edge, and from 5 MHz above or below the band edge increasing linearly to a level of 27 dBm/MHz at the band edge.

Note: the following formula is used to convert the EIRP to field strength

§1、  $E[\text{dB}\mu\text{V}/\text{m}] = \text{EIRP}[\text{dBm}] - 20 \log(d[\text{meters}]) + 104.77$ , where E = field strength and

d = distance at which field strength limit is specified in the rules;

§2、  $E[\text{dB}\mu\text{V}/\text{m}] = \text{EIRP}[\text{dBm}] + 95.2$ , for d = 3 meters

(7)Unwanted spurious emissions fallen in restricted bands per FCC Part15.205 shall comply with the general field strength limits set forth in § 15.209 as below table.



Frequency of emission (MHz)	Field strength(uV/m)	Field strength(dBuV/m)
0.009–0.490	2400/F(kHz)	/
0.490–1.705	24000/F(kHz)	/
1.705–30.0	30	/
30-88	100	40
88-216	150	43.5
216-960	200	46
Above960	500	54

MHz	MHz	MHz	GHz
0.090 - 0.110	16.42 - 16.423	399.9 - 410	4.5 - 5.15
0.495 - 0.505	16.69475 - 16.69525	608 - 614	5.35 - 5.46
2.1735 - 2.1905	16.80425 - 16.80475	960 - 1240	7.25 - 7.75
4.125 - 4.128	25.5 - 25.67	1300 - 1427	8.025 - 8.5
4.17725 - 4.17775	37.5 - 38.25	1435 - 1626.5	9.0 - 9.2
4.20725 - 4.20775	73 - 74.6	1645.5 - 1646.5	9.3 - 9.5
6.215 - 6.218	74.8 - 75.2	1660 - 1710	10.6 - 12.7
6.26775 - 6.26825	108 - 121.94	1718.8 - 1722.2	13.25 - 13.4
6.31175 - 6.31225	123 - 138	2200 - 2300	14.47 - 14.5
8.291 - 8.294	149.9 - 150.05	2310 - 2390	15.35 - 16.2
8.362 - 8.366	156.52475 - 156.52525	2483.5 - 2500	17.7 - 21.4
8.37625 - 8.38675	156.7 - 156.9	2690 - 2900	22.01 - 23.12
8.41425 - 8.41475	162.0125 - 167.17	3260 - 3267	23.6 - 24.0
12.29 - 12.293	167.72 - 173.2	3332 - 3339	31.2 - 31.8
12.51975 - 12.52025	240 - 285	3345.8 - 3358	36.43 - 36.5
12.57675 - 12.57725	322 - 335.4	3600 - 4400	( <sup>2</sup> )
13.36 - 13.41			

**Note: Please refer to the following plots:**

A value representative of an upper bound on out-of-band antenna gain (in dBi) shall be added to the measured antenna-port conducted emission power to compute EIRP within the specified measurement bandwidth. The upper bound on antenna gain for a device with a single RF output shall be selected as the maximum in-band gain of the antenna across all operating bands or 2 dBi, whichever is greater



**Test result**

**The signal beyond the limit is carrier.**

Sweep the whole frequency band through the range from 9kHz to the 10th harmonic of the carrier, and 9kHz-30MHz, the emissions more than 20 dB below the permissible value are not reported.

All spurious emissions at the antenna port is lower than -55dbm, so the total emission is lower than -39dbm, antenna gain is 16dbi, so compliance the requirements

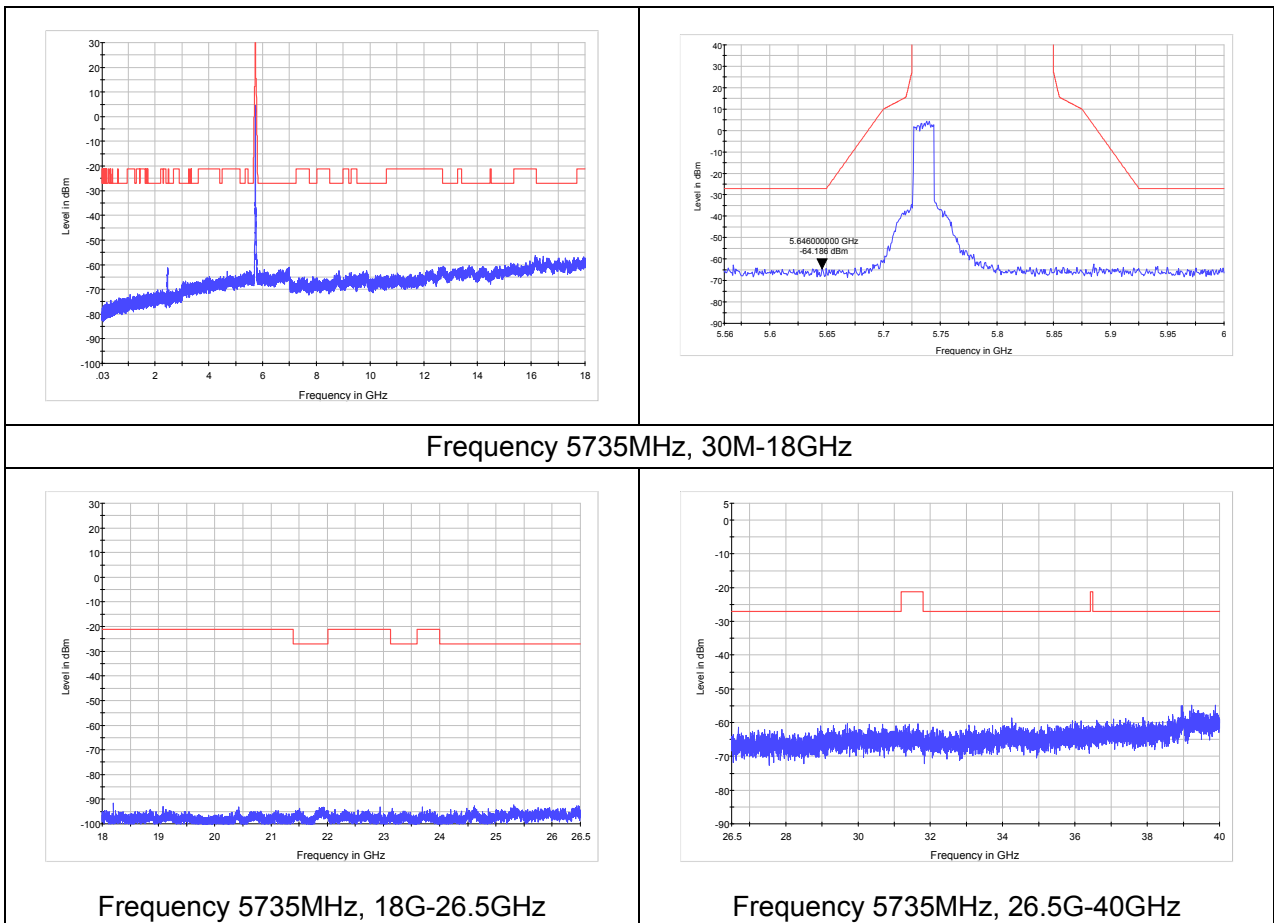

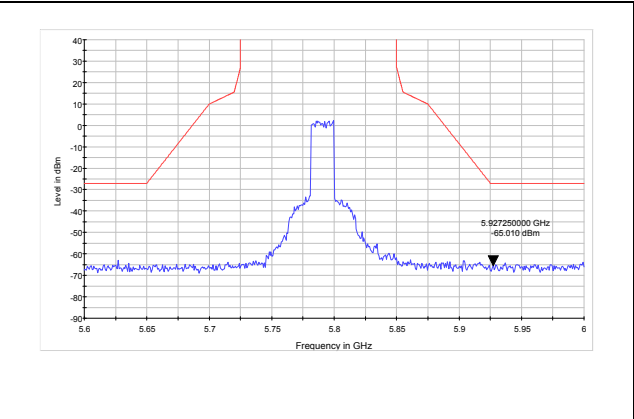
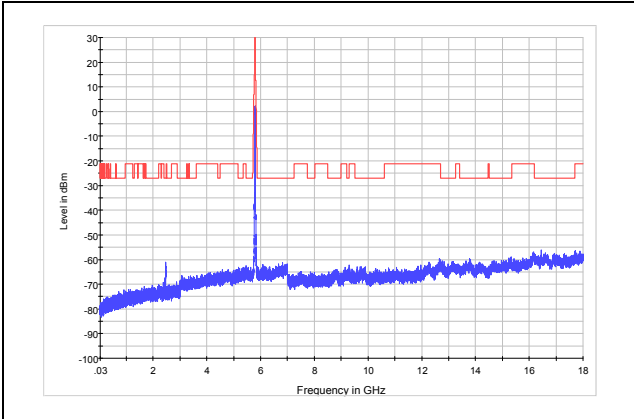

Frequency 5790MHz, 30M-18GHz

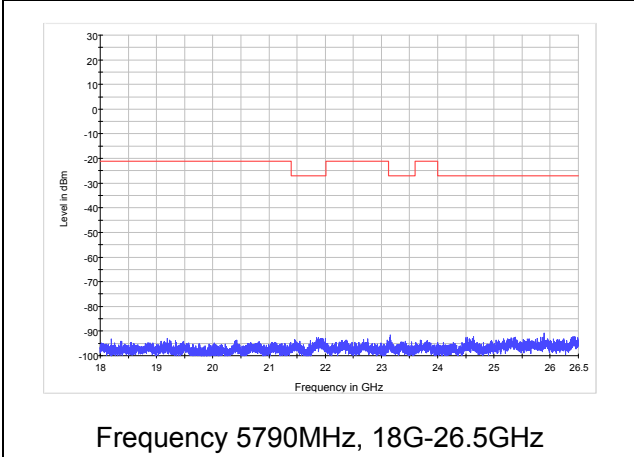

Frequency 5790MHz, 18G-26.5GHz

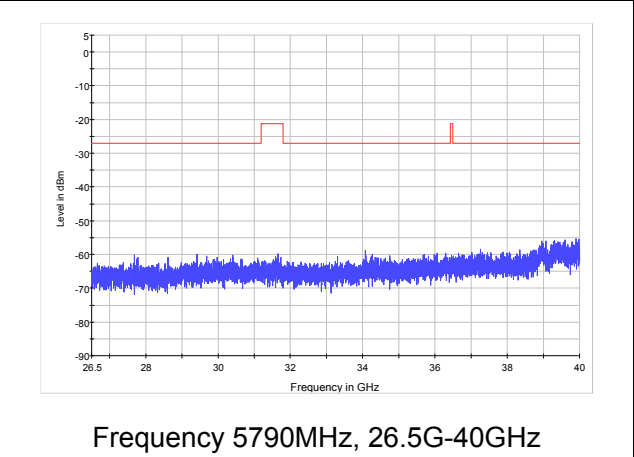

Frequency 5790MHz, 26.5G-40GHz

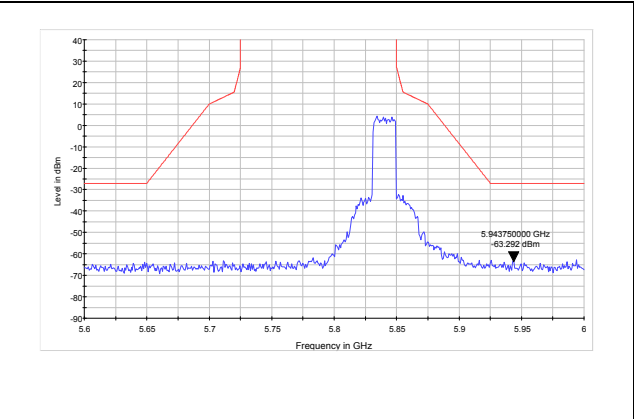
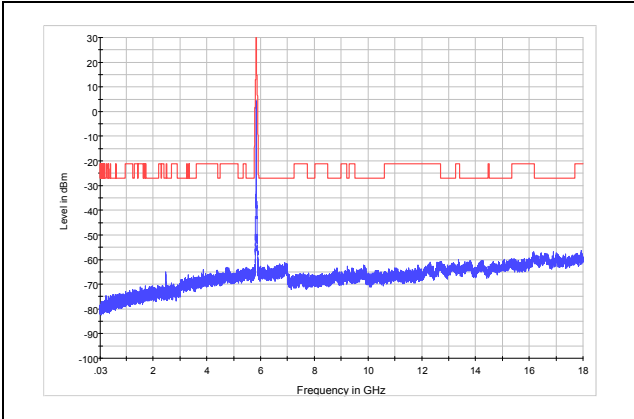

Frequency 5840MHz, 30M-18GHz

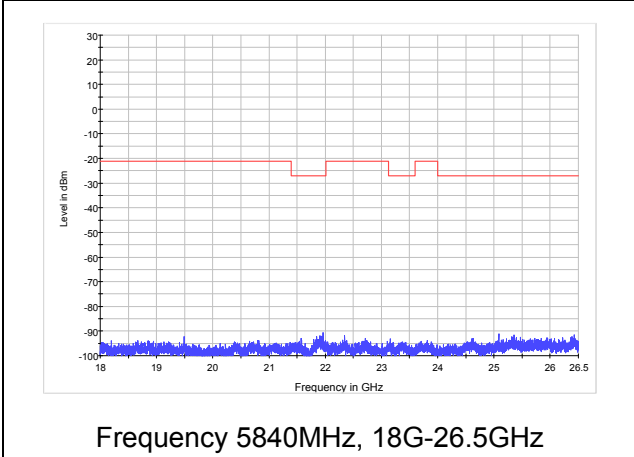

Frequency 5840MHz, 18G-26.5GHz

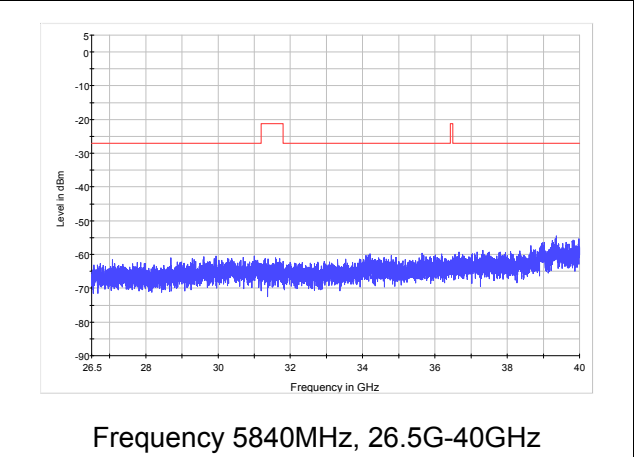

Frequency 5840MHz, 26.5G-40GHz

## 5.7. Conducted Emission

### Ambient condition

Temperature	Relative humidity	Pressure
23°C ~25°C	45%~50%	101.5kPa

### Methods of Measurement

The EUT IS placed on a non-metallic table of 80cm height above the horizontal metal reference ground plane. During the test, the EUT was operating in its typical mode. The test method is according to ANSI C63.10-2013. Connect the AC power line of the EUT to the LISN Use EMI receiver to detect the average and Quasi-peak value. RBW is set to 9kHz, VBW is set to 30kHz The measurement result should include both L line and N line.

The test is in transmitting mode.

### Test Setup

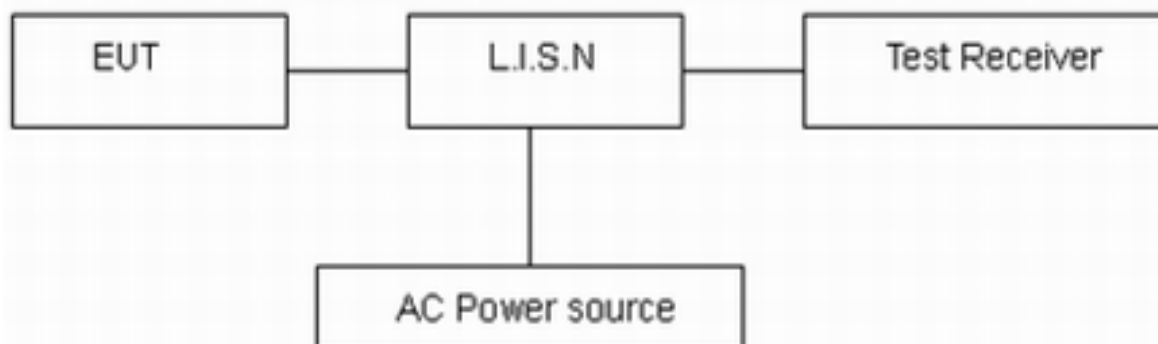

Note: AC Power source is used to change the voltage 110V/60Hz.

### Limits

Frequency (MHz)	Conducted Limits(dBμV)	
	Quasi-peak	Average
0.15 - 0.5	66 to 56 *	56 to 46*
0.5 - 5	56	46
5 - 30	60	50

\*: Decreases with the logarithm of the frequency.

### Measurement Uncertainty

The assessed measurement uncertainty to ensure 95% confidence level for the normal distribution is with the coverage factor  $k = 1.96$ ,  $U = 2.69$  dB.

**Test Results:**

Following plots, Blue trace uses the peak detection and Green trace uses the average detection.

**5735MHz**

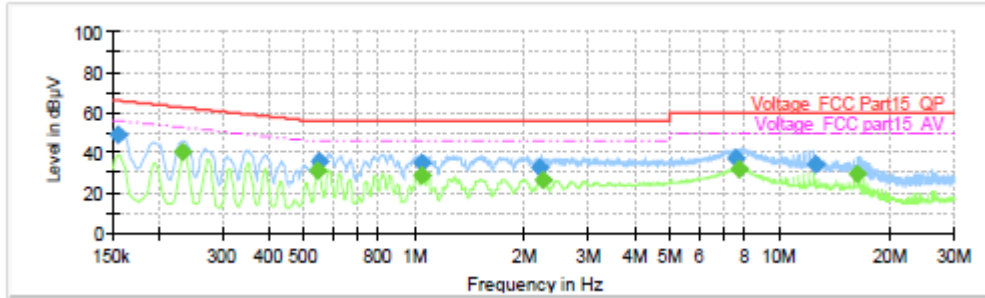

Frequency (MHz)	QuasiPeak (dBµV)	Average (dBµV)	Limit (dBµV)	Margin (dB)	Meas. Time (ms)	Bandwidth (kHz)	Line	Filter	Corr. (dB)
0.154500	48.54	---	65.75	17.21	1000.0	9.000	L1	ON	19.1
0.233250	---	40.26	52.33	12.07	1000.0	9.000	L1	ON	19.1
0.546000	---	30.99	46.00	15.01	1000.0	9.000	L1	ON	19.2
0.548250	35.49	---	56.00	20.51	1000.0	9.000	L1	ON	19.3
1.043250	34.76	---	56.00	21.24	1000.0	9.000	L1	ON	19.2
1.052250	---	28.59	46.00	17.41	1000.0	9.000	L1	ON	19.2
2.202000	32.30	---	56.00	23.70	1000.0	9.000	L1	ON	19.1
2.247000	---	26.16	46.00	19.84	1000.0	9.000	L1	ON	19.1
7.557000	36.87	---	60.00	23.13	1000.0	9.000	L1	ON	19.2
7.728000	---	31.83	50.00	18.17	1000.0	9.000	L1	ON	19.2
12.468750	34.43	---	60.00	25.57	1000.0	9.000	L1	ON	19.4
16.257750	---	29.77	50.00	20.23	1000.0	9.000	L1	ON	19.5

L line Conducted Emission from 150 KHz to 30 MHz

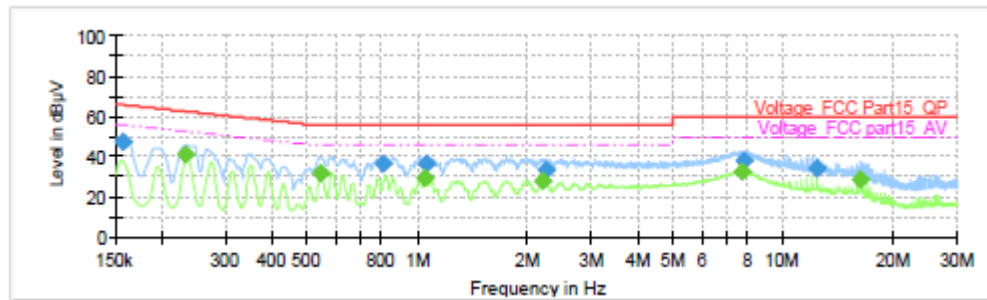

Frequency (MHz)	QuasiPeak (dBµV)	Average (dBµV)	Limit (dBµV)	Margin (dB)	Meas. Time (ms)	Bandwidth (kHz)	Line	Filter	Corr. (dB)
0.156750	47.57	---	65.63	18.07	1000.0	9.000	L1	ON	19.1
0.233250	---	41.19	52.33	11.15	1000.0	9.000	L1	ON	19.1
0.546000	---	31.98	46.00	14.02	1000.0	9.000	L1	ON	19.2
0.809250	36.13	---	56.00	19.87	1000.0	9.000	L1	ON	19.2
1.050000	---	29.40	46.00	16.60	1000.0	9.000	L1	ON	19.2
1.059000	36.20	---	56.00	19.80	1000.0	9.000	L1	ON	19.2
2.215500	---	27.55	46.00	18.45	1000.0	9.000	L1	ON	19.1
2.253750	33.42	---	56.00	22.58	1000.0	9.000	L1	ON	19.1
7.743750	---	32.68	50.00	17.32	1000.0	9.000	L1	ON	19.2
7.791000	38.05	---	60.00	21.95	1000.0	9.000	L1	ON	19.2
12.381000	33.91	---	60.00	26.09	1000.0	9.000	L1	ON	19.4
16.257750	---	28.84	50.00	21.16	1000.0	9.000	L1	ON	19.5

N line Conducted Emission from 150 KHz to 30 MHz

5790MHz

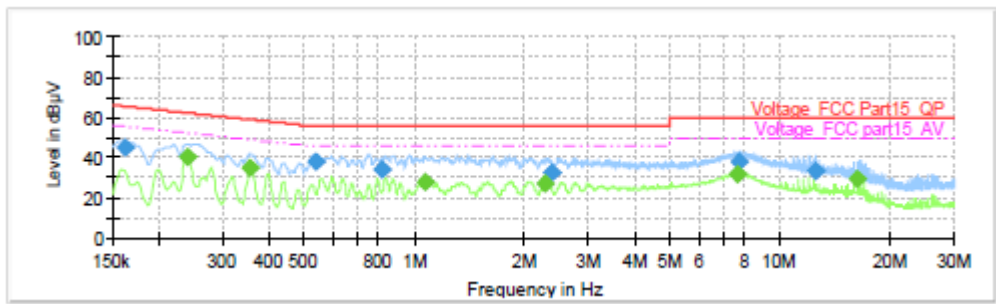

Frequency (MHz)	QuasiPeak (dBµV)	Average (dBµV)	Limit (dBµV)	Margin (dB)	Meas. Time (ms)	Bandwidth (kHz)	Line	Filter	Corr. (dB)
0.161250	45.16	---	65.40	20.24	1000.0	9.000	L1	ON	19.1
0.240000	---	39.96	52.10	12.13	1000.0	9.000	L1	ON	19.1
0.357000	---	35.00	48.80	13.80	1000.0	9.000	L1	ON	19.2
0.537000	38.01	---	56.00	17.99	1000.0	9.000	L1	ON	19.2
0.816000	34.09	---	56.00	21.91	1000.0	9.000	L1	ON	19.2
1.074750	---	28.20	46.00	17.80	1000.0	9.000	L1	ON	19.2
2.280750	---	27.29	46.00	18.71	1000.0	9.000	L1	ON	19.1
2.375250	32.47	---	56.00	23.53	1000.0	9.000	L1	ON	19.0
7.662750	---	31.80	50.00	18.20	1000.0	9.000	L1	ON	19.2
7.752750	37.77	---	60.00	22.23	1000.0	9.000	L1	ON	19.2
12.462000	32.96	---	60.00	27.04	1000.0	9.000	L1	ON	19.4
16.257750	---	29.63	50.00	20.37	1000.0	9.000	L1	ON	19.5

L line Conducted Emission from 150 KHz to 30 MHz

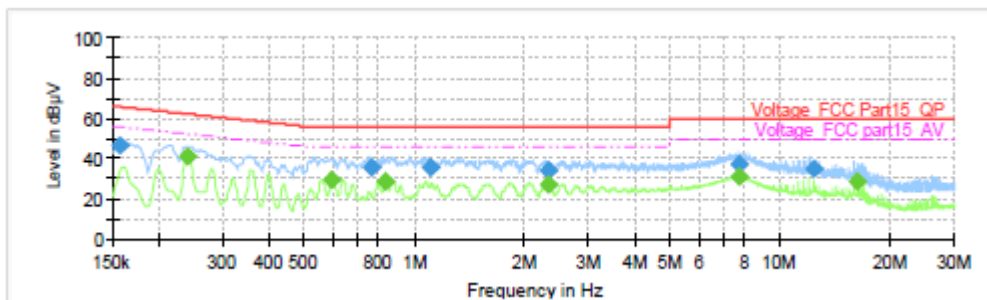

Frequency (MHz)	QuasiPeak (dBµV)	Average (dBµV)	Limit (dBµV)	Margin (dB)	Meas. Time (ms)	Bandwidth (kHz)	Line	Filter	Corr. (dB)
0.156750	46.37	---	65.63	19.27	1000.0	9.000	N	ON	19.1
0.240000	---	40.77	52.10	11.33	1000.0	9.000	N	ON	19.1
0.595500	---	29.15	46.00	16.85	1000.0	9.000	N	ON	19.3
0.759750	35.42	---	56.00	20.58	1000.0	9.000	N	ON	19.2
0.836250	---	29.04	46.00	16.96	1000.0	9.000	N	ON	19.2
1.108500	35.39	---	56.00	20.61	1000.0	9.000	N	ON	19.2
2.323500	---	27.22	46.00	18.78	1000.0	9.000	N	ON	19.0
2.325750	33.89	---	56.00	22.11	1000.0	9.000	N	ON	19.0
7.728000	---	31.01	50.00	18.99	1000.0	9.000	N	ON	19.2
7.764000	37.06	---	60.00	22.94	1000.0	9.000	N	ON	19.2
12.383250	34.61	---	60.00	25.39	1000.0	9.000	N	ON	19.4
16.257750	---	28.80	50.00	21.20	1000.0	9.000	N	ON	19.4

N line Conducted Emission from 150 KHz to 30 MHz





5840MHz

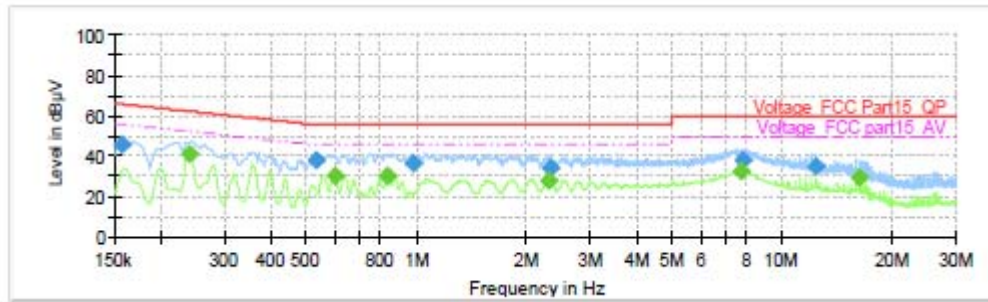

Frequency (MHz)	QuasiPeak (dBµV)	Average (dBµV)	Limit (dBµV)	Margin (dB)	Meas. Time (ms)	Bandwidth (kHz)	Line	Filter	Corr. (dB)
0.156750	45.65	---	65.63	19.99	1000.0	9.000	L1	ON	19.1
0.240000	---	41.22	52.10	10.88	1000.0	9.000	L1	ON	19.1
0.534750	38.03	---	56.00	17.97	1000.0	9.000	L1	ON	19.2
0.597750	---	30.48	46.00	15.52	1000.0	9.000	L1	ON	19.3
0.836250	---	30.16	46.00	15.84	1000.0	9.000	L1	ON	19.2
0.980250	36.41	---	56.00	19.59	1000.0	9.000	L1	ON	19.2
2.305500	---	28.21	46.00	17.79	1000.0	9.000	L1	ON	19.0
2.337000	34.06	---	56.00	21.94	1000.0	9.000	L1	ON	19.0
7.773000	---	32.30	50.00	17.70	1000.0	9.000	L1	ON	19.2
7.804500	38.11	---	60.00	21.89	1000.0	9.000	L1	ON	19.2
12.385500	34.97	---	60.00	25.03	1000.0	9.000	L1	ON	19.4
16.257750	---	29.29	50.00	20.71	1000.0	9.000	L1	ON	19.5

L line Conducted Emission from 150 KHz to 30 MHz

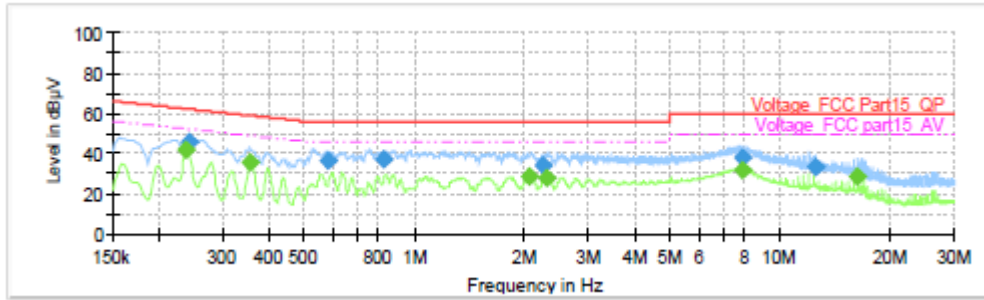

Frequency (MHz)	QuasiPeak (dBµV)	Average (dBµV)	Limit (dBµV)	Margin (dB)	Meas. Time (ms)	Bandwidth (kHz)	Line	Filter	Corr. (dB)
0.237750	---	41.74	52.17	10.43	1000.0	9.000	N	ON	19.1
0.242250	45.72	---	62.02	16.30	1000.0	9.000	N	ON	19.1
0.357000	---	36.04	48.80	12.76	1000.0	9.000	N	ON	19.2
0.584250	36.82	---	56.00	19.18	1000.0	9.000	N	ON	19.3
0.827250	37.47	---	56.00	18.53	1000.0	9.000	N	ON	19.2
2.069250	---	28.56	46.00	17.44	1000.0	9.000	N	ON	19.1
2.251500	34.05	---	56.00	21.95	1000.0	9.000	N	ON	19.1
2.292000	---	28.11	46.00	17.89	1000.0	9.000	N	ON	19.0
7.901250	37.79	---	60.00	22.21	1000.0	9.000	N	ON	19.2
7.910250	---	31.97	50.00	18.03	1000.0	9.000	N	ON	19.2
12.466500	33.60	---	60.00	26.40	1000.0	9.000	N	ON	19.4
16.257750	---	28.60	50.00	21.40	1000.0	9.000	N	ON	19.4

N line Conducted Emission from 150 KHz to 30 MHz



## 6. Main Test Instruments

Date of Testing: May 1, 2017~ May 5, 2017 and July 16, 2017

Name	Manufacturer	Type	Serial Number	Calibration Date	Expiration Time
Spectrum Analyzer	R&S	FSV30	100815	2016-12-16	2017-12-15
EMI Test Receiver	R&S	ESCI	100948	2016-06-01	2017-05-31
Loop Antenna	SCHWARZBECK	FMZB1519	1519-047	2017-02-28	2020-02-27
TRILOG Broadband Antenna	Schwarzbeck	VULB 9163	9163-201	2014-12-06	2017-12-05
Double Ridged Waveguide Horn Antenna	R&S	HF907	100126	2014-12-06	2017-12-05
Standard Gain Horn	ETS-Lindgren	3160-09	00102644	2015-01-30	2018-01-29
EMI Test Receiver	R&S	ESCS30	100138	2016-12-16	2017-12-15
LISN	R&S	ENV216	101171	2016-12-16	2019-12-15
Spectrum Analyzer	Agilent	N9010A	MY47191109	2016-05-21	2017-05-20
RF Cable	Agilent	SMA 15cm	0001	2017-02-06	2017-08-05

Date of Testing: April 3, 2019~ June 11, 2019

Name	Manufacturer	Type	Serial Number	Calibration Date	Expiration Date
Spectrum Analyzer	KEYSIGHT	N9020A	MY54420163	2018-12-16	2019-12-15
RF Cable	Agilent	SMA 15cm	0001	2019-03-15	2019-06-14
TEMPERATURE CHAMBER	WEISS	VT4002	582261194500 10	2018-12-16	2019-12-15
AV Power Meter	R&S	NRP	104306	2019-05-19	2020-05-18
Power Probe	R&S	NRP-Z21	104799	2019-05-19	2020-05-18
DC Power Supply	GWINSTEK	GPS-3030D	GEP882653	2018-05-20	2020-05-19

\*\*\*\*\*END OF REPORT \*\*\*\*\*

## ANNEX A: Product Change Description

Article 1: Difference description:

The difference between model **eA680-950(old)** and model **eA680-950(new)** is show in the below table:

	Model	eA680-950(old)	eA680-950(new)
Frequency	LTE BAND	The same	The same
	UMTS BAND	NA	NA
	GSM BAND	NA	NA
	IC	The same	The same
	Antenna	The same	The same
WiFi	Wi-Fi	The same	The same
	IC	The same	The same
	Antenna	The same	The same
Hardware	BOM	1151 V100	1151 V210
	FLASH	The same	The same
	PCB	CL1EA950R VER.E	CL2EA950R VER.A
	USB Port	The same	The same
	Hardware	CL1EA950R	CL2EA950R
Software	Software	different	Add UL 2CA
RF	RF circuit	The same	The same
NV	NV	The same	The same
Appearance	Dimension	The same	The same
	Color	The same	The same
	Display Unit	The same	The same
	ID	The same	The same
Accessory	Adapter	NA	NA