



中国认可
国际互认
检测
TESTING
CNAS L2264

RF TEST REPORT

Applicant Huawei Technologies Co. ,Ltd.
FCC ID QISEA680-950
Product LTE DAU
Model eA680-950
Report No. RHA1704-0043RF02R5
Issue Date July 24, 2017

TA Technology (Shanghai) Co., Ltd. tested the above equipment in accordance with the requirements in **FCC CFR47 Part 15E (2017)**. The test results show that the equipment tested is capable of demonstrating compliance with the requirements as documented in this report.

Performed by: Xianqing Li

Approved by: Kai Xu

TA Technology (Shanghai) Co., Ltd.

No.145, Jintang Rd, Tangzhen Industry Park, Pudong Shanghai, China

TEL: +86-021-50791141/2/3

FAX: +86-021-50791141/2/3-8000

TABLE OF CONTENT

1. Test Laboratory	4
1.1. Notes of the test report.....	4
1.2. Test facility	4
1.3. Testing Location.....	5
2. General Description of Equipment under Test.....	6
3. Test Information	7
4. Test Configuration	8
5. Test Case Results	9
5.1. Occupied Bandwidth	9
5.2. Power Output –Conducted	11
5.3. Frequency Stability.....	13
5.4. Power Spectral Density	17
5.5. Unwanted Emission	19
5.6. Conducted spurious emissions at antenna port	42
5.7. Conducted Emission	47
6. Main Test Instruments.....	50
ANNEX A: EUT Appearance and Test Setup	51
A.1 EUT Appearance	51
A.2 Test Setup	52

Summary of measurement results

Number	Summary of measurements of results	Clause in FCC rules	Verdict
1	Maximum peak conducted output power	15.407(a)	PASS
2	Occupied bandwidth	15.407(a)	PASS
3	Frequency stability	15.407(g)	PASS
4	Maximum power spectral density	15.407(a)	PASS
5	Unwanted Emissions	15.407(b)	PASS
6	Conducted spurious emissions at antenna port	15.407(b)	PASS
7	Conducted Emissions	15.207	PASS
Date of Testing: May 1, 2017~ May 5, 2017 and July 16, 2017			

1. Test Laboratory

1.1. Notes of the test report

This report shall not be reproduced in full or partial, without the written approval of **TA technology (shanghai) co., Ltd.** The results documented in this report apply only to the tested sample, under the conditions and modes of operation as described herein. Measurement Uncertainties were not taken into account and are published for informational purposes only. This report is written to support regulatory compliance of the applicable standards stated above. This report must not be used by the client to claim product certification, approval, or endorsement by CNAS or any government agencies.

1.2. Test facility

CNAS (accreditation number: L2264)

TA Technology (Shanghai) Co., Ltd. has obtained the accreditation of China National Accreditation Service for Conformity Assessment (CNAS).

FCC (recognition number is 428261)

TA Technology (Shanghai) Co., Ltd. has been listed on the US Federal Communications Commission list of test facilities recognized to perform electromagnetic emissions measurements.

IC (recognition number is 8510A)

TA Technology (Shanghai) Co., Ltd. has been listed by industry Canada to perform electromagnetic emission measurement.

VCCI (recognition number is C-4595, T-2154, R-4113, G-766)

TA Technology (Shanghai) Co., Ltd. has been listed by industry Japan to perform electromagnetic emission measurement.

A2LA (Certificate Number: 3857.01)

TA Technology (Shanghai) Co., Ltd. has been listed by American Association for Laboratory Accreditation to perform electromagnetic emission measurement.

1.3. Testing Location

Company: TA Technology (Shanghai) Co., Ltd.
Address: No.145, Jintang Rd, Tangzhen Industry Park, Pudong
City: Shanghai
Post code: 201201
Country: P. R. China
Contact: Xu Kai
Telephone: +86-021-50791141/2/3
Fax: +86-021-50791141/2/3-8000
Website: <http://www.ta-shanghai.com>
E-mail: xukai@ta-shanghai.com

2. General Description of Equipment under Test

Client Information

Applicant	Huawei Technologies Co., Ltd.
Applicant address	Administration Building, Headquarters of Huawei Technologies Co., Ltd., Bantian, Longgang District, Shenzhen, 518129, P.R.China
Manufacturer	Huawei Technologies Co., Ltd.
Manufacturer address	Administration Building, Headquarters of Huawei Technologies Co., Ltd., Bantian, Longgang District, Shenzhen, 518129, P.R.China

General information

EUT Description			
Model:	eA680-950		
IMEI:	864756030003133		
Hardware Version:	Ver.E		
Software Version:	V100R001C00		
Power Supply:	AC Power Supply		
Antenna Type:	Internal Antenna		
Antenna Gain:	16dBi		
additional beamforming gain:	0dBi		
Test Mode:	5725 MHz - 5850 MHz		
Modulation Type:	QPSK/16QAM/64QAM		
Max. Conducted Power	17.35 dBm		
Operating Frequency Range(s)	Mode	Tx (MHz)	Rx (MHz)
	5G	5725 - 5850	5725 - 5850
EUT Accessory			
Adapter	Manufacture: DONGGUAN SHILONG FUHUA ELECTRONIC CO., LTD. Model : PoE35-54A		
Note: The information of the EUT is declared by the manufacturer. Please refer to the specifications or user manual for details.			

3. Test Information

According to the specifications of the manufacturer, it must comply with the requirements of the following standards:

FCC CFR47 Part 15E (2017) Unlicensed National Information Infrastructure Devices

ANSI C63.10 (2013)

KDB 789033 D02 General UNII Test Procedures New Rules v01r04

KDB 662911 D01 Multiple Transmitter Output v02r01

4. Test Configuration

Test Mode

The EUT was programmed to be in continuously transmitting mode and the transmit duty cycle is not less than 98%.

The EUT has been associated with peripherals and configuration operated in a manner tended to maximize its emission characteristics in a typical application.

The radiated emission was measured in the following position: EUT stand-up position (Z axis), lie-down position (X, Y axis). The worst emission was found in stand-up position (Z axis) and the worst case was recorded.

In order to find the worst case condition, Pre-tests are needed at the presence of different data rate. Preliminary tests have been done on all the configuration for confirming worst case. Data rate below means worst-case rate of each test item.

5. Test Case Results

5.1. Occupied Bandwidth

Ambient condition

Temperature	Relative humidity	Pressure
23°C ~25°C	45%~50%	101.5kPa

Method of Measurement

The EUT was connected to the spectrum analyzer through an external attenuator (20dB) and a known loss cable.

Set RBW = 100 kHz, VBW $\geq 3 \times$ RBW, measure the maximum width of the emission that is constrained by the frequencies associated with the two outermost amplitude points (upper and lower frequencies) that are attenuated by 6 dB relative to the maximum level measured in the fundamental emission.

Set RBW = 1 % to 5 % of the OBW, VBW $\geq 3 \times$ RBW, Use the 99 % power bandwidth function of the instrument (if available).

If the instrument does not have a 99 % power bandwidth function, the trace data points are recovered and directly summed in power units. The recovered amplitude data points, beginning at the lowest frequency, are placed in a running sum until 0.5 % of the total is reached; that frequency is recorded as the lower frequency. The process is repeated until 99.5 % of the total is reached; that frequency is recorded as the upper frequency. The 99% occupied bandwidth is the difference between these two frequencies.

Test Setup

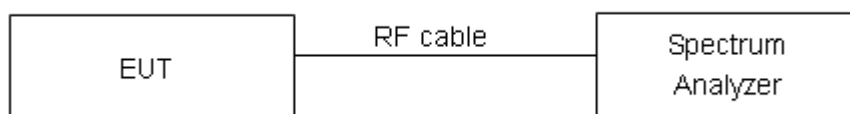

Limits

Rule FCC Part 15.407(a)(5)

Within the 5.725-5.85 GHz band, the minimum 6 dB bandwidth of U-NII devices shall be at least 500 kHz.

Measurement Uncertainty

The assessed measurement uncertainty to ensure 95% confidence level for the normal distribution is with the coverage factor $k = 2$, $U = 936$ Hz.



Test Results:

Carrier frequency (MHz)	99% bandwidth (MHz)	Minimum -6 dB bandwidth (MHz)	Limit (kHz)	Conclusion
5735	17.891	17.98	500	PASS
5790	17.879	17.98	500	PASS
5840	17.888	18.00	500	PASS

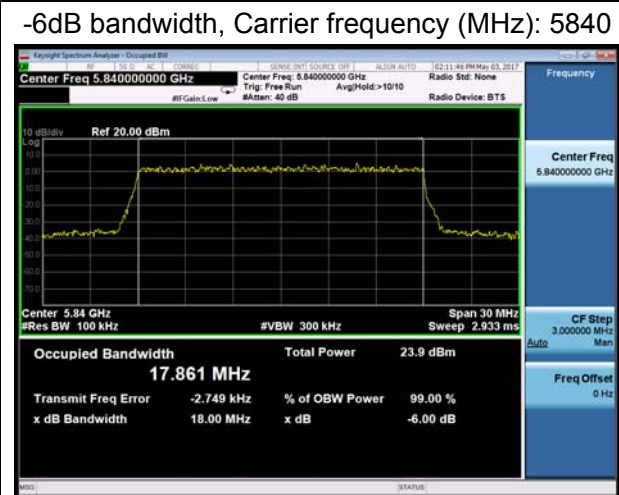
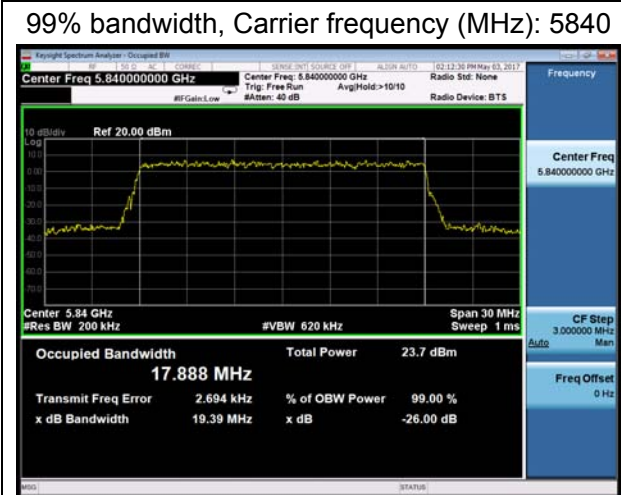
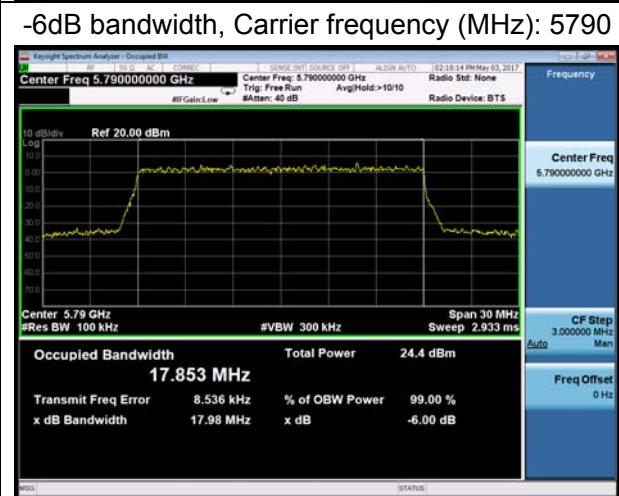
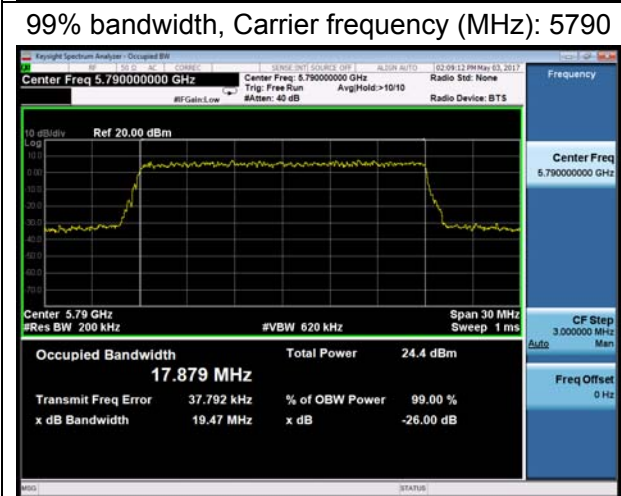
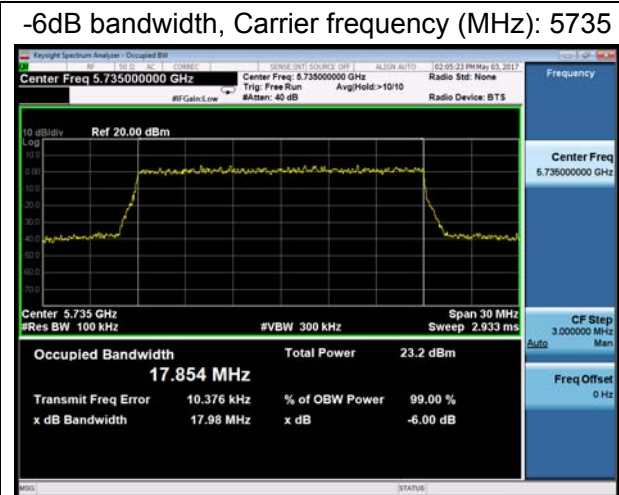
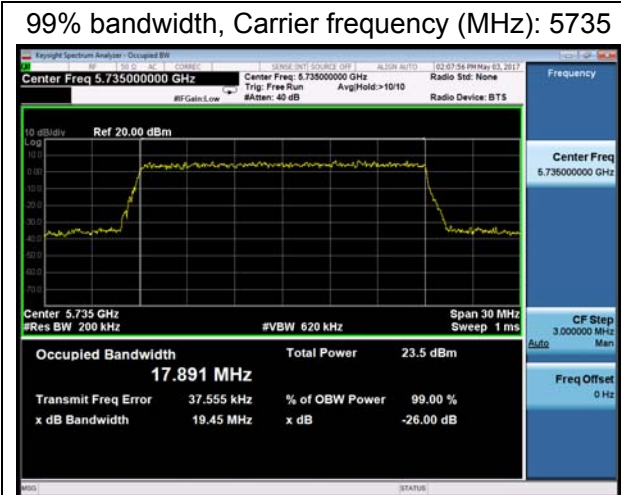

5.2. Power Output –Conducted

Ambient condition

Temperature	Relative humidity	Pressure
23°C ~25°C	45%~50%	101.5kPa

Methods of Measurement

During the process of the testing, The EUT was connected to the average power meter through an external attenuator and a known loss cable. The EUT is max power transmission with proper modulation. We use Maximum average Conducted Output Power Level Method in KDB789033 for this test

The conducted Power is measured at each antenna port. The measured results at the various antenna ports are then summed mathematically.

Test Setup

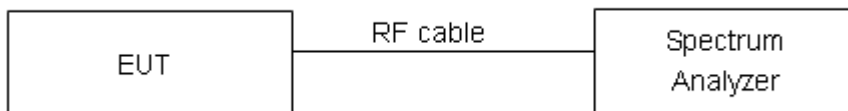

Limits

Rule FCC Part 15.407(a)(3)

For the band 5.725-5.85 GHz, the maximum conducted output power over the frequency band of operation shall not exceed 1 W. In addition, the maximum power spectral density shall not exceed 30 dBm in any 500-kHz band. If transmitting antennas of directional gain greater than 6 dBi are used, both the maximum conducted output power and the maximum power spectral density shall be reduced by the amount in dB that the directional gain of the antenna exceeds 6 dBi.

Measurement Uncertainty

The assessed measurement uncertainty to ensure 95% confidence level for the normal distribution is with the coverage factor $k = 2$, $U = 0.44$ dB.

Test Results

Frequency (MHz)	Average Output Power (dBm)	Limit (dBm)	Conclusion
5735	17.35	20.00	PASS
5790	16.44	20.00	PASS
5840	16.01	20.00	PASS

Frequency (MHz): 5735

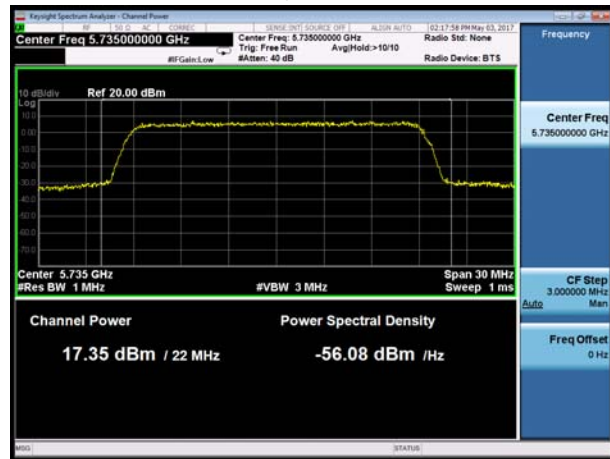

Frequency (MHz): 5790



Frequency (MHz): 5840

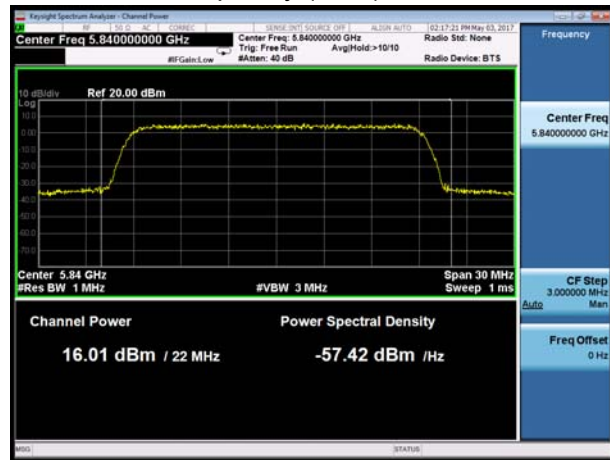

5.3. Frequency Stability

Ambient condition

Temperature	Relative humidity	Pressure
23°C ~25°C	45%~50%	101.5kPa

Method of Measurement

1. Frequency stability with respect to ambient temperature

a) Supply the EUT with a nominal ac voltage or install a new or fully charged battery in the EUT. If possible, a dummy load shall be connected to the EUT because an antenna near the metallic walls of an environmental test chamber could affect the output frequency of the EUT. If the EUT is equipped with a permanently attached, adjustable-length antenna, then the EUT shall be placed in the center of the chamber with the antenna adjusted to the shortest length possible. Turn ON the EUT and tune it to one of the number of frequencies shown in 5.6.

b) Couple the unlicensed wireless device output to the measuring instrument by connecting an antenna to the measuring instrument with a suitable length of coaxial cable and placing the measuring antenna near the EUT (e.g., 15 cm away), or by connecting a dummy load to the measuring instrument, through an attenuator if necessary.

c) Adjust the location of the measurement antenna and the controls on the measurement instrument to obtain a suitable signal level (i.e., a level that will not overload the measurement instrument but is strong enough to allow measurement of the operating or fundamental frequency of the EUT).

d) Turn the EUT OFF and place it inside the environmental temperature chamber. For devices that have oscillator heaters, energize only the heater circuit.

e) Set the temperature control on the chamber to the highest specified in the regulatory requirements for the type of device and allow the oscillator heater and the chamber temperature to stabilize.

f) While maintaining a constant temperature inside the environmental chamber, turn the EUT ON and record the operating frequency at startup, and at 2 minutes, 5 minutes, and 10 minutes after the EUT is energized. Four measurements in total are made.

g) Measure the frequency at each of frequencies specified in 5.6.

h) Switch OFF the EUT but do not switch OFF the oscillator heater.

i) Lower the chamber temperature by not more than 10 C, and allow the temperature inside the chamber to stabilize.

j) Repeat step f) through step i) down to the lowest specified temperature.

2. Frequency stability when varying supply voltage

Unless otherwise specified, these tests shall be made at ambient room temperature (+15 C to +25 C). An antenna shall be connected to the antenna output terminals of the EUT if possible. If the EUT is equipped with or uses an adjustable-length antenna, then it shall be fully extended.

a) Supply the EUT with nominal voltage or install a new or fully charged battery in the EUT. Turn ON the EUT and couple its output to a frequency counter or other frequency-measuring instrument.

- b) Tune the EUT to one of the number of frequencies required in 5.6. Adjust the location of the measurement antenna and the controls on the measurement instrument to obtain a suitable signal level (i.e., a level that will not overload the measurement instrument but is strong enough to allow measurement of the operating or fundamental frequency of the EUT).
- c) Measure the frequency at each of the frequencies specified in 5.6.
- d) Repeat the above procedure at 85% and 115% of the nominal supply voltage.

Limit

Manufacturers of U-NII devices are responsible for ensuring frequency stability such that an emission is maintained within the band of operation under all conditions of normal operation as specified in the users manual.

Measurement Uncertainty

The assessed measurement uncertainty to ensure 95% confidence level for the normal distribution is with the coverage factor $k = 2$, $U = 936\text{Hz}$

**Test Results**

Voltage (V)	Temperature (°C)	Test Results			
		5735MHz			
		1min	2min	5min	10min
110	-20	5735.009	5735.008	5735.001	5734.991
110	-10	5735.017	5734.998	5734.995	5734.985
110	0	5735.011	5735.005	5734.999	5734.980
110	10	5735.014	5734.997	5735.008	5734.982
110	20	5735.010	5735.007	5735.006	5734.981
110	30	5735.012	5735.002	5735.006	5734.983
110	40	5735.020	5735.008	5735.008	5734.980
110	50	5735.021	5735.008	5735.012	5734.974
93.5	20	5735.016	5735.006	5735.004	5734.967
107.5	20	5735.008	5735.003	5735.004	5734.964
MHz		0.008	-0.003	-0.005	-0.036
PPM		1.3838987	-0.45329074	-0.8698842	-6.2381392

Voltage (V)	Temperature (°C)	Test Results			
		5790MHz			
		1min	2min	5min	10min
110	-20	5789.998	5790.003	5789.996	5790.004
110	-10	5790.001	5790.008	5790.004	5790.007
110	0	5790.002	5790.016	5790.002	5790.014
110	10	5790.007	5790.007	5790.003	5790.016
110	20	5790.001	5790.006	5790.007	5790.019
110	30	5790.003	5790.015	5790.013	5790.012
110	40	5789.996	5790.008	5790.022	5790.020
110	50	5790.003	5790.014	5790.026	5790.013
93.5	20	5790.011	5790.010	5790.021	5790.019
107.5	20	5790.020	5790.013	5790.027	5790.014
MHz		-0.004	0.003	-0.004	0.004
PPM		-0.614282	0.595512067	-0.7232005	0.68497153

Voltage (V)	Temperature (°C)	Test Results			
		5840MHz			
		1min	2min	5min	10min
110	-20	5840.007	5839.999	5840.007	5839.997
110	-10	5840.001	5840.002	5840.002	5839.993
110	0	5839.994	5840.001	5840.001	5839.990
110	10	5839.991	5839.992	5840.007	5839.998
110	20	5839.983	5839.997	5840.014	5839.995
110	30	5839.991	5839.992	5840.004	5840.000
110	40	5839.991	5839.982	5840.001	5839.993
110	50	5839.984	5839.976	5839.998	5839.989
93.5	20	5839.992	5839.969	5840.000	5839.991
107.5	20	5839.997	5839.964	5839.997	5839.991
	MHz	-0.017	-0.036	-0.003	-0.011
	PPM	-2.924426	-6.08147743	-0.5982631	-1.8419499

5.4. Power Spectral Density

Ambient condition

Temperature	Relative humidity	Pressure
23°C ~25°C	45%~50%	101.5kPa

Method of Measurement

The EUT was connected to the spectrum analyzer through an external attenuator (20dB) and a known loss cable.

Set RBW = 510 kHz, VBW = 1.5MHz for the band 5.725-5.85 GHz

The conducted PSD is measured at each antenna port. The measured results at the various antenna ports are then summed mathematically.

Test setup

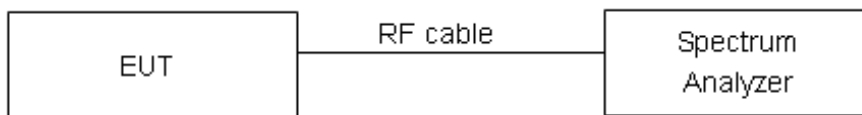

Limits

Rule FCC Part 15.407(a)(3)

For the band 5.725-5.85 GHz, the maximum power spectral density shall not exceed 30 dBm in any 500-kHz band. If transmitting antennas of directional gain greater than 6 dBi are used, both the maximum conducted output power and the maximum power spectral density shall be reduced by the amount in dB that the directional gain of the antenna exceeds 6 dBi.

Frequency Bands/MHz	Limits
5725-5850	30dBm/500kHz

Measurement Uncertainty

The assessed measurement uncertainty to ensure 95% confidence level for the normal distribution is with the coverage factor $k = 2$, $U = 0.75\text{dB}$.



Test Results:

Frequency (MHz)	Power Spectral Density (dBm /MHz)	Limit (dBm/500kHz)	Conclusion
5735	1.082	20.00	PASS
5790	1.694	20.00	PASS
5840	1.620	20.00	PASS

Frequency (MHz): 5735

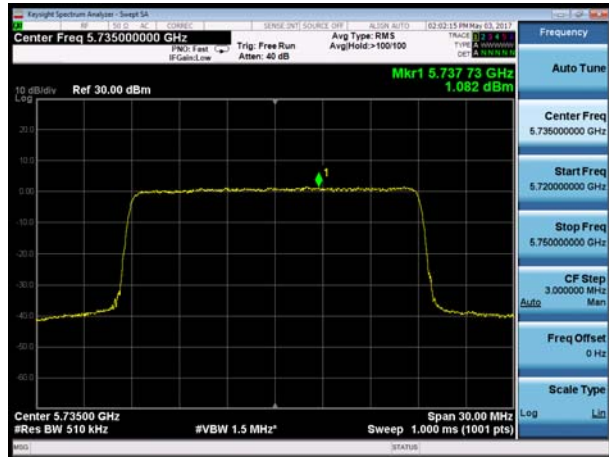

Frequency (MHz): 5790

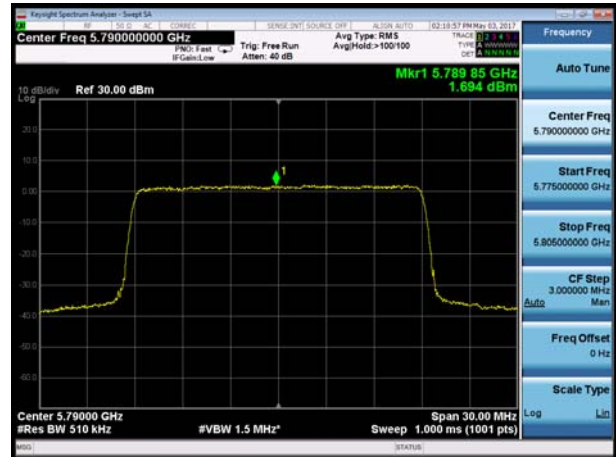

Frequency (MHz): 5840

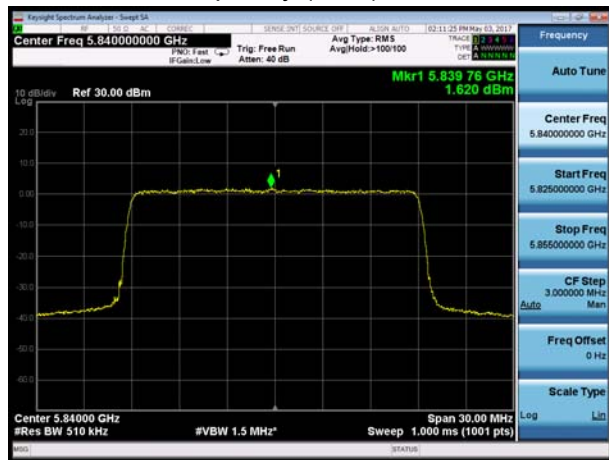

5.5. Unwanted Emission

Ambient condition

Temperature	Relative humidity	Pressure
23°C ~25°C	45%~50%	101.5kPa

Method of Measurement

The test set-up was made in accordance to the general provisions of ANSI C63.10-2013. The Equipment Under Test (EUT) was set up on a non-conductive table in the semi-anechoic chamber. The test was performed at the distance of 3 m between the EUT and the receiving antenna. The radiated emissions measurements were made in a typical installation configuration. Sweep the whole frequency band range from 9kHz to the 10th harmonic of the carrier, and the emissions less than 20 dB below the permissible value are reported.

During the test, the height of receive antenna shall be moved from 1 to 4 meters, and the antenna shall be performed under horizontal and vertical polarization. The turntable shall be rotated from 0 to 360 degrees for detecting the maximum of radiated spurious signal level. The measurements shall be repeated with orthogonal polarization of the test antenna. The data of cable loss and antenna factor has been calibrated in full testing frequency range before the testing.

Set the spectrum analyzer in the following:

Below 1GHz (detector: Peak and Quasi-Peak)

RBW=100kHz / VBW=300kHz / Sweep=AUTO

Above 1GHz (detector: Peak):

(a) PEAK: RBW=1MHz VBW=3MHz/ Sweep=AUTO

(b) AVERAGE: RBW=1MHz / VBW=3MHz / Sweep=AUTO

The radiated emission was measured in the following position: EUT stand-up position (Z axis), lie-down position (X, Y axis). The worst emission was found in stand-up position (Z axis) and the worst case was recorded.

The test is in transmitting mode.

9KHz~~~30MHz

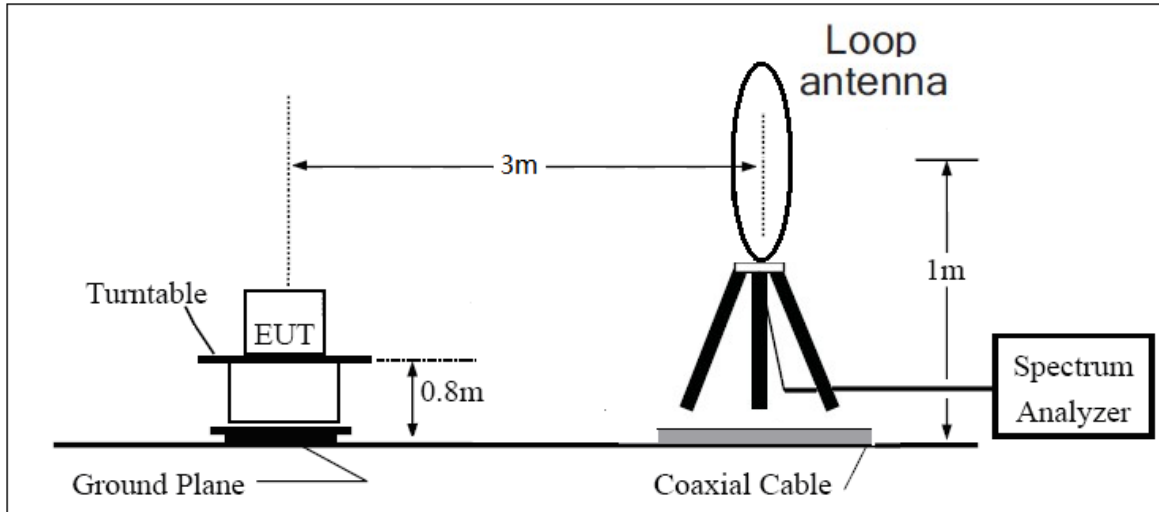

30MHz~~~ 1GHz

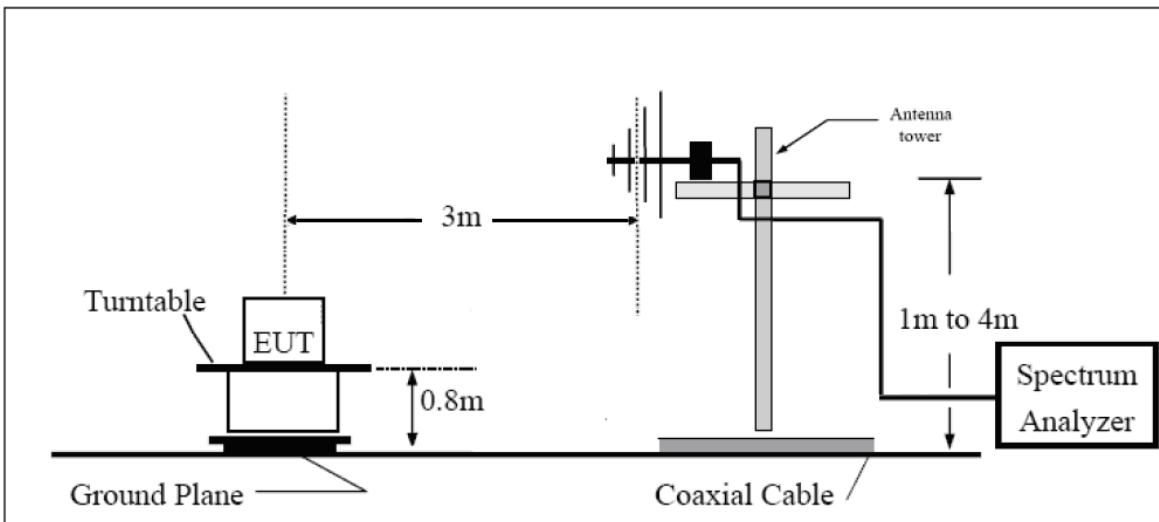

Above 1GHz

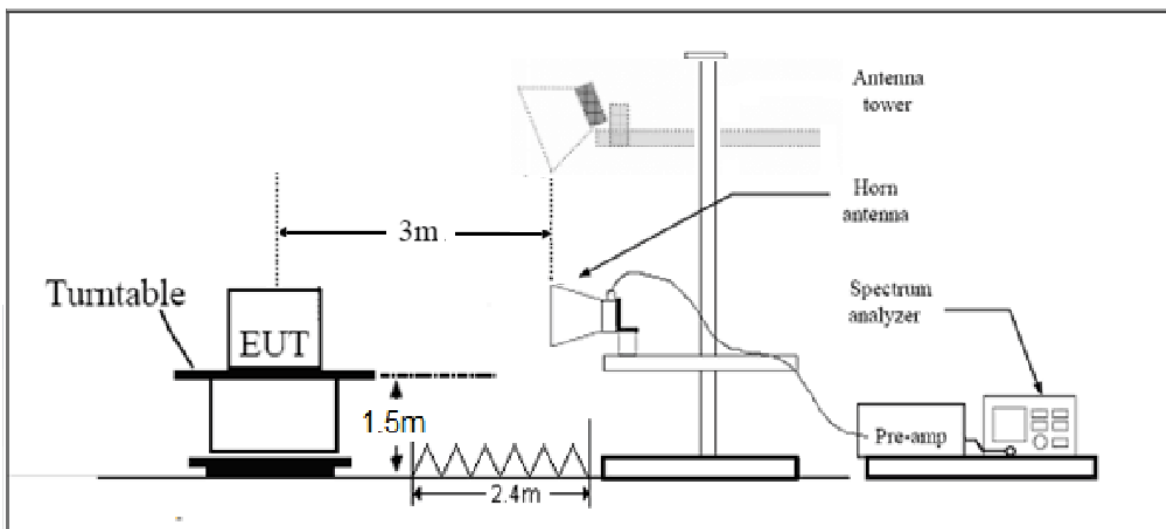

Note: Area side:2.4mX3.6m

Limits

FCC §407 (b) Undesirable emission limits. Except as shown in paragraph (b)(7) of this section, the maximum emissions outside of the frequency bands of operation shall be attenuated in accordance with the following limits:

For transmitters operating in the 5725-5850 MHz band: All emissions shall be limited to a level of -27 dBm/MHz at 75 MHz or more above or below the band edge increasing linearly to 10 dBm/MHz at 25 MHz above or below the band edge, and from 25 MHz above or below the band edge increasing linearly to a level of 15.6 dBm/MHz at 5 MHz above or below the band edge, and from 5 MHz above or below the band edge increasing linearly to a level of 27 dBm/MHz at the band edge.

Note: the following formula is used to convert the EIRP to field strength

§1、 $E[\text{dB}\mu\text{V}/\text{m}] = \text{EIRP}[\text{dBm}] - 20 \log(d[\text{meters}]) + 104.77$, where E = field strength and

d = distance at which field strength limit is specified in the rules;

§2、 $E[\text{dB}\mu\text{V}/\text{m}] = \text{EIRP}[\text{dBm}] + 95.2$, for d = 3 meters

(1) Unwanted spurious emissions fallen in restricted bands per FCC Part15.205 shall comply with the general field strength limits set forth in § 15.209 as below table.

Frequency of emission (MHz)	Field strength(uV/m)	Field strength(dBuV/m)
0.009–0.490	2400/F(kHz)	/
0.490–1.705	24000/F(kHz)	/
1.705–30.0	30	/
30-88	100	40
88-216	150	43.5
216-960	200	46
Above 960	500	54

MHz	MHz	MHz	GHz
0.090 - 0.110	16.42 - 16.423	399.9 - 410	4.5 - 5.15
0.495 - 0.505	16.69475 - 16.69525	608 - 614	5.35 - 5.46
2.1735 - 2.1905	16.80425 - 16.80475	960 - 1240	7.25 - 7.75
4.125 - 4.128	25.5 - 25.67	1300 - 1427	8.025 - 8.5
4.17725 - 4.17775	37.5 - 38.25	1435 - 1626.5	9.0 - 9.2
4.20725 - 4.20775	73 - 74.6	1645.5 - 1646.5	9.3 - 9.5
6.215 - 6.218	74.8 - 75.2	1660 - 1710	10.6 - 12.7
6.26775 - 6.26825	108 - 121.94	1718.8 - 1722.2	13.25 - 13.4
6.31175 - 6.31225	123 - 138	2200 - 2300	14.47 - 14.5
8.291 - 8.294	149.9 - 150.05	2310 - 2390	15.35 - 16.2
8.362 - 8.366	156.52475 - 156.52525	2483.5 - 2500	17.7 - 21.4
8.37625 - 8.38675	156.7 - 156.9	2690 - 2900	22.01 - 23.12
8.41425 - 8.41475	162.0125 - 167.17	3260 - 3267	23.6 - 24.0
12.29 - 12.293	167.72 - 173.2	3332 - 3339	31.2 - 31.8
12.51975 - 12.52025	240 - 285	3345.8 - 3358	36.43 - 36.5
12.57675 - 12.57725	322 - 335.4	3600 - 4400	(²)
13.36 - 13.41			

Measurement Uncertainty

The assessed measurement uncertainty to ensure 95% confidence level for the normal distribution is with the coverage factor $k = 1.96$.

Frequency	Uncertainty
9KHz-30MHz	3.55 dB
30MHz-200MHz	4.19 dB
200MHz-1GHz	3.63 dB
1GHz-26.5G	3.68 dB
26.5G-40GHz	4.76dB



Test Results:

PASS

The signal beyond the limit is carrier.

Frequency 5735MHz

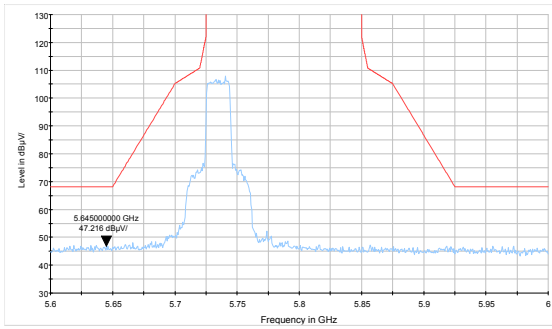

Frequency 5840MHz

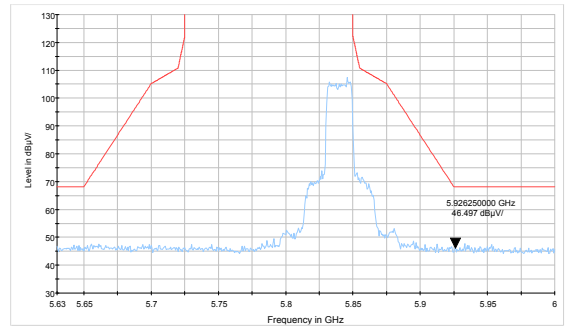

Result of RE

Test result

Sweep the whole frequency band through the range from 9kHz to the 10th harmonic of the carrier, and 9kHz-30MHz, the emissions more than 20 dB below the permissible value are not reported.

5735MHz

FCC RE 0.03-1GHz QP Class B

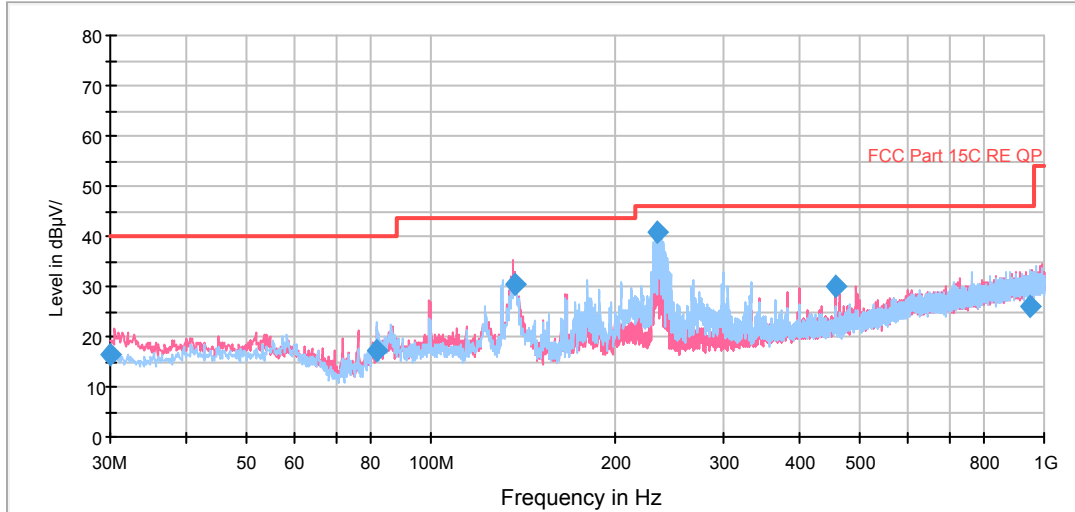

Radiates Emission from 30MHz to 1GHz

Frequency (MHz)	Quasi-Peak (dBuV/m)	Height (cm)	Polarization	Azimuth (deg)	Reading value (dBuV/m)	Correct Factor (dB)	Margin (dB)	Limit (dBuV/m)
30.080000	16.6	100.0	V	213.0	4.5	12.1	23.4	40.0
81.652500	17.1	114.0	H	0.0	7.9	9.2	22.9	40.0
136.693750	30.3	100.0	V	43.0	21.2	9.1	13.2	43.5
234.588750	40.8	114.0	H	242.0	27.3	13.5	5.2	46.0
458.168750	30.0	100.0	V	195.0	11.0	19.0	16.0	46.0
947.422500	26.0	100.0	H	22.0	-1.2	27.2	20.0	46.0

- Remark:**
1. Quasi-Peak = Reading value + Correction factor
 2. Correction Factor = Antenna factor+ Insertion loss(cable loss+amplifier gain)
 3. Margin = Limit – Quasi-Peak

RE 1G-3GHz PK+AV

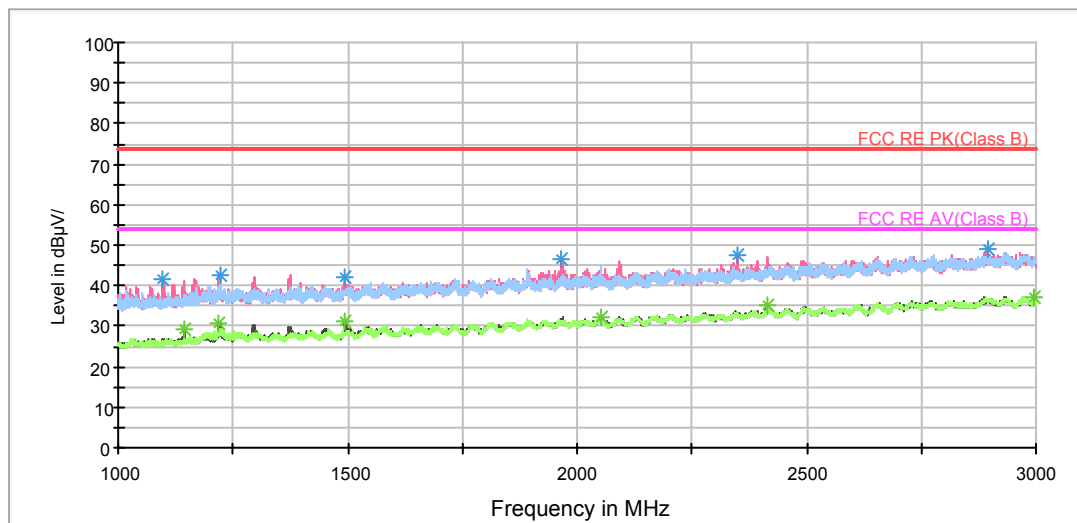

Radiates Emission from 1GHz to 3GHz

Frequency (MHz)	Peak (dBuV/m)	Height (cm)	Polarization	Azimuth (deg)	Reading value (dBuV/m)	Correct Factor (dB)	Margin (dB)	Limit (dBuV/m)
1096.750000	41.7	100.0	V	241.0	50.6	-8.9	32.3	74
1222.250000	42.6	100.0	V	231.0	50.4	-7.8	31.4	74
1493.500000	42.1	100.0	V	169.0	48.8	-6.7	31.9	74
1964.750000	46.4	100.0	V	231.0	49.7	-3.3	27.6	74
2350.500000	47.6	100.0	V	214.0	48.9	-1.3	26.4	74
2893.750000	48.8	100.0	V	143.0	46.7	2.1	25.2	74

Remark: 1. Correction Factor = Antenna factor+ Insertion loss (cable loss + amplifier gain)

Frequency (MHz)	Average (dBuV/m)	Height (cm)	Polarization	Azimuth (deg)	Reading value (dBuV/m)	Correct Factor (dB)	Margin (dB)	Limit (dBuV/m)
1144.750000	29.4	100.0	V	231.0	37.9	-8.5	24.6	54
1220.250000	30.9	100.0	V	222.0	38.8	-7.9	23.1	54
1494.250000	31.0	100.0	V	134.0	37.7	-6.7	23.0	54
2052.250000	32.1	100.0	V	187.0	35.3	-3.2	21.9	54
2413.000000	35.2	100.0	H	68.0	35.7	-0.5	18.8	54
2997.500000	37.3	100.0	V	196.0	35.0	2.3	16.7	54

Remark: 1. Correction Factor = Antenna factor+ Insertion loss (cable loss + amplifier gain)

RE 3-18GHz PK+AV_BELL SWEEP

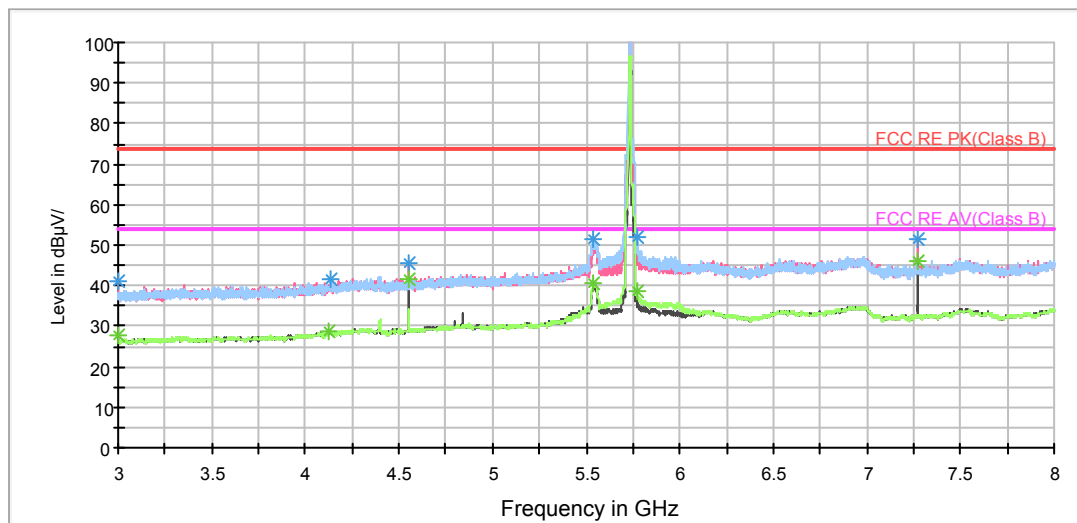

Note: The signal beyond the limit is carrier.
Radiates Emission from 3GHz to 8GHz

Frequency (MHz)	Peak (dBuV/m)	Height (cm)	Polarization	Azimuth (deg)	Reading value (dBuV/m)	Correct Factor (dB)	Margin (dB)	Limit (dBuV/m)
3000.000000	41.0	205.0	V	261.0	44.2	-3.2	33.0	74
4136.250000	41.8	300.0	H	0.0	42.1	-0.3	32.2	74
4550.000000	45.6	205.0	V	63.0	44.8	0.8	28.4	74
5532.500000	51.5	105.0	H	0.0	48.3	3.2	22.5	74
5773.750000	52.1	205.0	H	47.0	48.3	3.8	21.9	74
7270.625000	51.7	105.0	V	178.0	44.7	7.0	22.3	74

Remark: 1. Correction Factor = Antenna factor+ Insertion loss (cable loss + amplifier gain)

Frequency (MHz)	Average (dBuV/m)	Height (cm)	Polarization	Azimuth (deg)	Reading value (dBuV/m)	Correct Factor (dB)	Margin (dB)	Limit (dBuV/m)
3000.000000	27.6	205.0	V	261.0	30.8	-3.2	26.4	54
4129.375000	28.7	205.0	H	250.0	29.1	-0.4	25.3	54
4550.000000	41.5	205.0	V	63.0	40.7	0.8	12.5	54
5542.500000	40.7	300.0	V	100.0	37.5	3.2	13.3	54
5769.375000	38.5	205.0	H	47.0	34.8	3.7	15.5	54
7271.250000	46.0	105.0	V	178.0	39.0	7.0	8.0	54

Remark: 1. Correction Factor = Antenna factor+ Insertion loss (cable loss + amplifier gain)

RE 3-18GHz PK+AV_BELL SWEEP

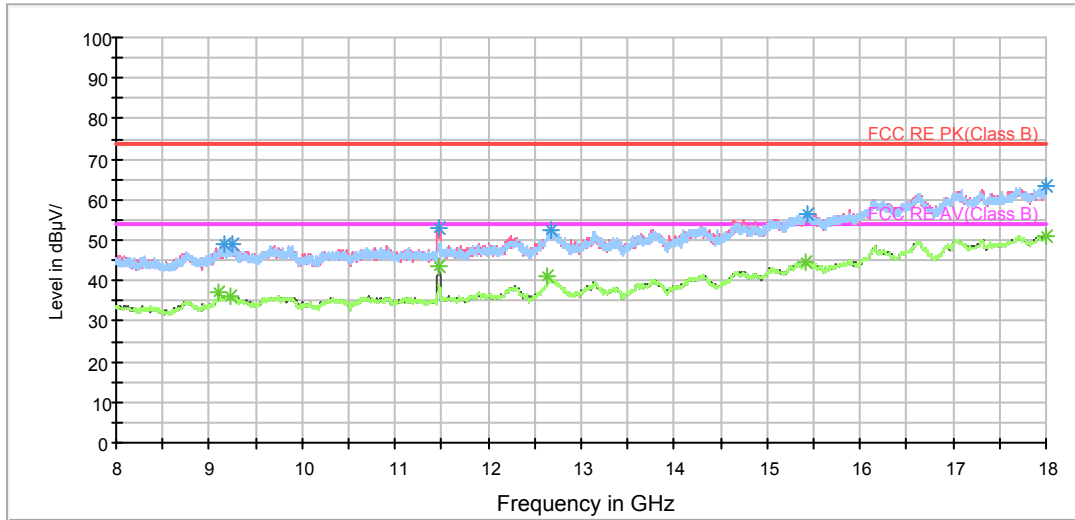

Radiates Emission from 8GHz to 18GHz

Frequency (MHz)	Peak (dBuV/m)	Height (cm)	Polarization	Azimuth (deg)	Reading value (dBuV/m)	Correct Factor (dB)	Margin (dB)	Limit (dBuV/m)
9153.750000	48.8	300.0	V	324.0	38.6	10.2	25.2	74
9260.000000	49.1	205.0	V	10.0	39.7	9.4	24.9	74
11461.250000	53.2	205.0	V	226.0	43.0	10.2	20.8	74
12686.250000	52.6	205.0	H	297.0	38.4	14.2	21.4	74
15425.000000	56.4	300.0	H	0.0	37.0	19.4	17.6	74
17998.750000	63.5	300.0	V	162.0	38.1	25.4	10.5	74

Remark: 1. Correction Factor = Antenna factor+ Insertion loss (cable loss + amplifier gain)

Frequency (MHz)	Average (dBuV/m)	Height (cm)	Polarization	Azimuth (deg)	Reading value (dBuV/m)	Correct Factor (dB)	Margin (dB)	Limit (dBuV/m)
9100.000000	37.2	205.0	V	172.0	27.7	9.5	16.8	54
9238.750000	36.3	205.0	V	118.0	26.4	9.9	17.7	54
11471.250000	43.6	205.0	V	226.0	33.4	10.2	10.4	54
12640.000000	41.0	105.0	V	0.0	26.4	14.6	13.0	54
15422.500000	44.7	300.0	V	162.0	25.3	19.4	9.3	54
17998.750000	51.2	300.0	H	339.0	25.8	25.4	2.8	54

Remark: 1. Correction Factor = Antenna factor+ Insertion loss (cable loss + amplifier gain)

RE 18-26.5GHz PK+AV

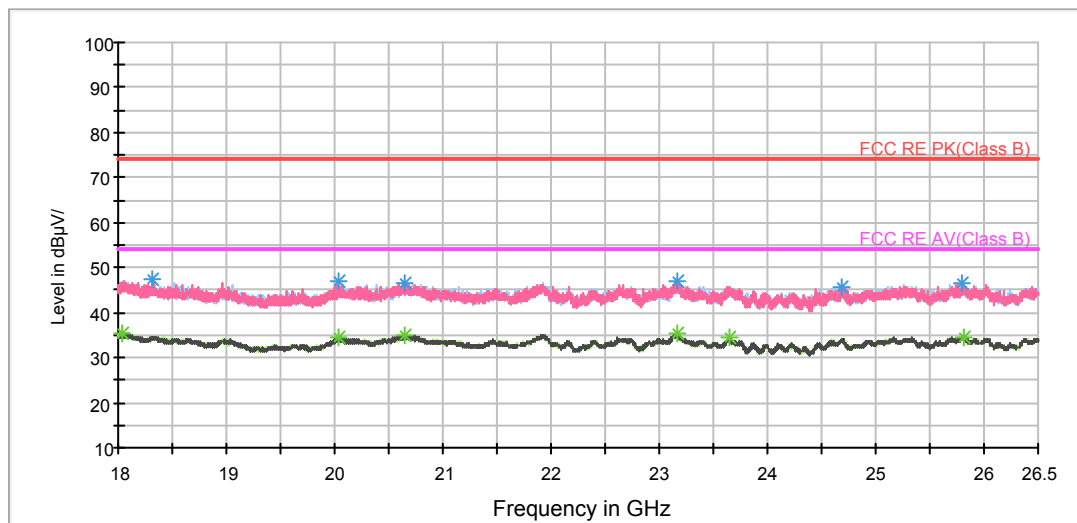

Radiates Emission from 18GHz to 26.5GHz

Frequency (MHz)	Peak (dBuV/m)	Polarization	Azimuth (deg)	Reading value (dBuV/m)	Correct Factor (dB)	Margin (dB)	Limit (dBuV/m)
18324.062500	47.5	V	15.0	50.7	-3.2	26.5	74.0
20045.312500	46.8	H	311.0	52.5	-5.7	27.2	74.0
20647.750000	46.3	V	226.0	52.9	-6.6	27.7	74.0
23160.562500	47.1	H	0.0	53.2	-6.1	26.9	74.0
24681.000000	45.8	H	0.0	51.8	-6.0	28.2	74.0
25800.875000	46.5	V	205.0	52.0	-5.5	27.5	74.0

Remark: 1. Correction Factor = Antenna factor+ Insertion loss (cable loss + amplifier gain)

Frequency (MHz)	Average (dBuV/m)	Polarization	Azimuth (deg)	Reading value (dBuV/m)	Correct Factor (dB)	Margin (dB)	Limit (dBuV/m)
18029.750000	35.3	H	129.0	37.2	-1.9	18.7	54.0
20045.312500	34.5	V	142.0	40.2	-5.7	19.5	54.0
20649.875000	35.1	V	216.0	41.7	-6.6	18.9	54.0
23160.562500	35.5	H	0.0	41.6	-6.1	18.5	54.0
23650.375000	34.3	V	153.0	40.2	-5.9	19.7	54.0
25813.625000	34.7	H	0.0	40.2	-5.5	19.3	54.0

Remark: 1. Correction Factor = Antenna factor+ Insertion loss (cable loss + amplifier gain)

RE 26.5-40GHz PK+AV

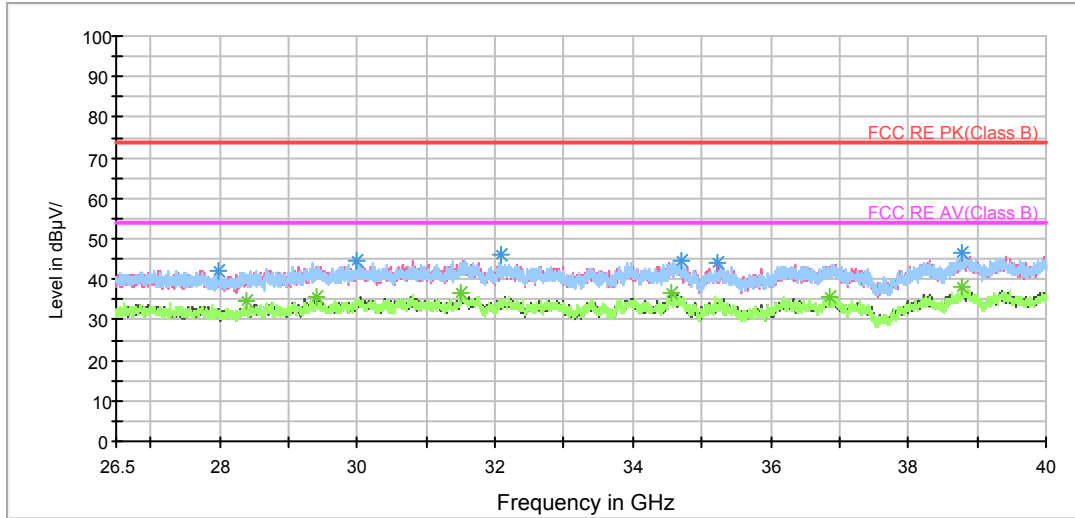

Radiates Emission from 26.5GHz to 40GHz

Frequency (MHz)	Peak (dBuV/m)	Polarization	Azimuth (deg)	Reading value (dBuV/m)	Correct Factor (dB)	Margin (dB)	Limit (dBuV/m)
27985.000000	42.2	V	235.0	43.9	-1.7	31.8	74.0
29988.062500	44.5	V	177.0	44.9	-0.4	29.5	74.0
32080.562500	46.3	H	19.0	46.8	-0.5	27.7	74.0
34701.250000	44.3	H	9.0	45.2	-0.9	29.7	74.0
35217.625000	43.8	V	0.0	44.4	-0.6	30.2	74.0
38779.937500	46.3	H	19.0	43.6	2.7	27.7	74.0

Remark: 1. Correction Factor = Antenna factor+ Insertion loss (cable loss + amplifier gain)

Frequency (MHz)	Average (dBuV/m)	Polarization	Azimuth (deg)	Reading value (dBuV/m)	Correct Factor (dB)	Margin (dB)	Limit (dBuV/m)
28381.562500	34.4	H	299.0	35.9	-1.5	19.6	54.0
29414.312500	35.8	H	0.0	36.7	-0.9	18.2	54.0
31516.937500	36.5	H	0.0	37.0	-0.5	17.5	54.0
34547.687500	36.8	V	137.0	37.8	-1.0	17.2	54.0
36856.187500	35.7	V	245.0	35.8	-0.1	18.3	54.0
38788.375000	37.9	V	235.0	35.2	2.7	16.1	54.0

Remark: 1. Correction Factor = Antenna factor+ Insertion loss (cable loss + amplifier gain)

5790MHz

FCC RE 0.03-1GHz QP Class B

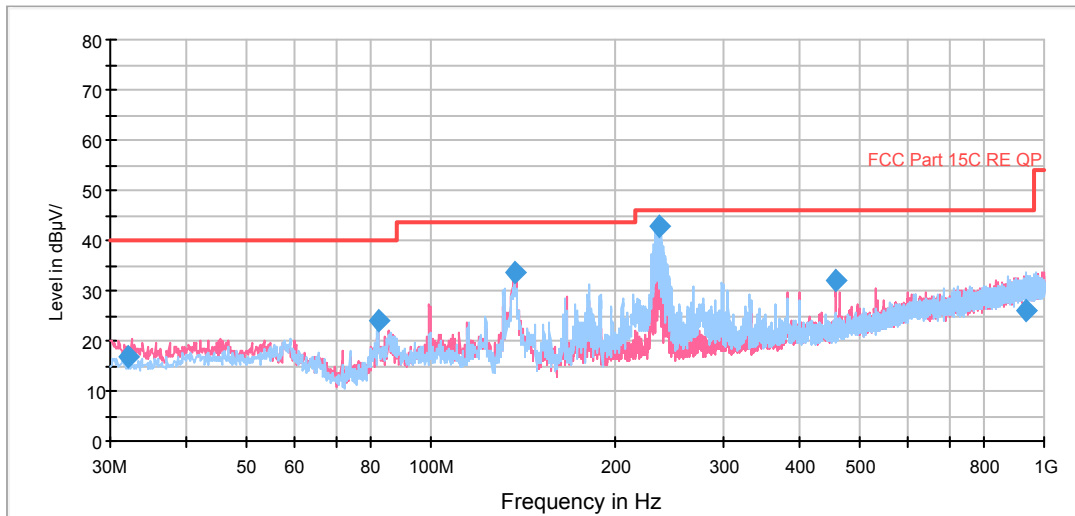

Radiates Emission from 30MHz to 1GHz

Frequency (MHz)	Quasi-Peak (dBuV/m)	Height (cm)	Polarization	Azimuth (deg)	Reading value (dBuV/m)	Correct Factor (dB)	Margin (dB)	Limit (dBuV/m)
32.146250	16.9	100.0	V	211.0	4.9	12.0	23.1	40.0
82.057500	23.8	125.0	H	327.0	14.6	9.2	16.2	40.0
136.820000	33.5	100.0	V	36.0	24.4	9.1	10.0	43.5
235.357500	42.9	125.0	H	235.0	29.1	13.8	3.1	46.0
458.376250	31.9	100.0	V	191.0	12.9	19.0	14.1	46.0
935.980000	25.9	125.0	H	188.0	-1.1	27.0	20.1	46.0

- Remark: 1. Quasi-Peak = Reading value + Correction factor
 2. Correction Factor = Antenna factor+ Insertion loss(cable loss+amplifier gain)
 3. Margin = Limit – Quasi-Peak

RE 1G-3GHz PK+AV

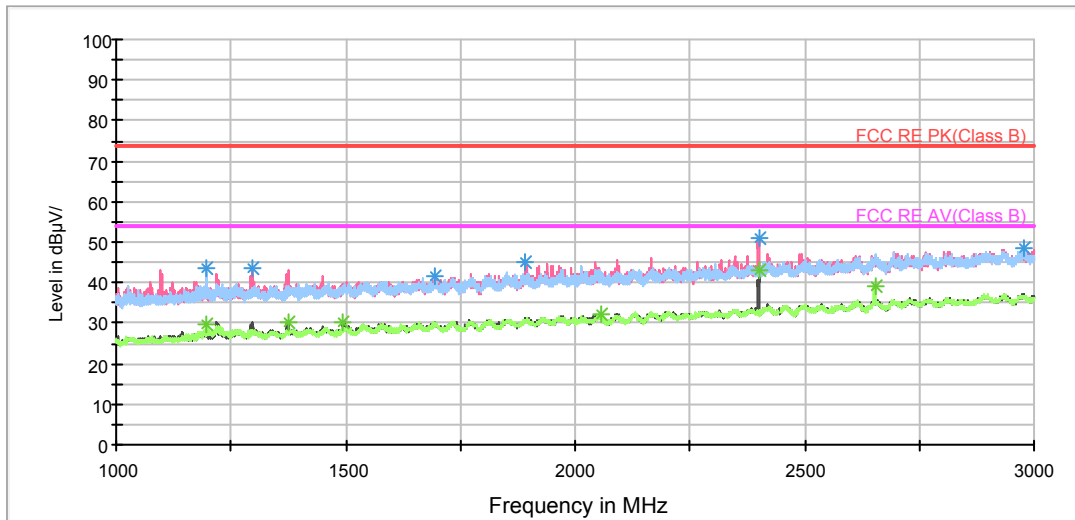

Radiates Emission from 1GHz to 3GHz

Frequency (MHz)	Peak (dBuV/m)	Height (cm)	Polarization	Azimuth (deg)	Reading value (dBuV/m)	Correct Factor (dB)	Margin (dB)	Limit (dBuV/m)
1195.750000	43.4	100.0	H	220.0	51.6	-8.2	30.6	74
1297.000000	43.8	100.0	V	187.0	51.6	-7.8	30.2	74
1693.250000	41.7	100.0	H	150.0	46.7	-5.0	32.3	74
1892.250000	45.1	100.0	V	268.0	49.3	-4.2	28.9	74
2400.500000	50.8	100.0	V	294.0	52.0	-1.2	23.2	74
2979.750000	48.4	100.0	V	354.0	46.2	2.2	25.6	74

Remark: 1. Correction Factor = Antenna factor+ Insertion loss (cable loss + amplifier gain)

Frequency (MHz)	Average (dBuV/m)	Height (cm)	Polarization	Azimuth (deg)	Reading value (dBuV/m)	Correct Factor (dB)	Margin (dB)	Limit (dBuV/m)
1195.750000	29.7	100.0	H	220.0	37.9	-8.2	24.3	54
1373.750000	30.3	100.0	V	187.0	37.4	-7.1	23.7	54
1493.750000	30.2	100.0	V	320.0	36.9	-6.7	23.8	54
2056.000000	32.0	100.0	V	170.0	35.2	-3.2	22.0	54
2400.250000	42.9	100.0	V	294.0	44.1	-1.2	11.1	54
2653.000000	39.3	100.0	H	229.0	38.9	0.4	14.7	54

Remark: 1. Correction Factor = Antenna factor+ Insertion loss (cable loss + amplifier gain)

RE 3-18GHz PK+AV_BELL SWEEP

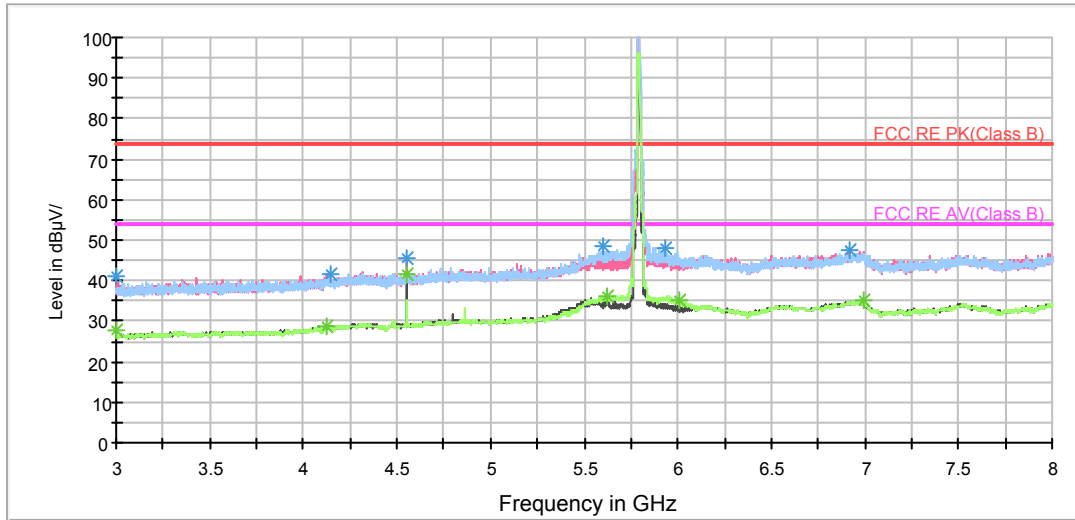

Note: The signal beyond the limit is carrier.
Radiates Emission from 3GHz to 8GHz

Frequency (MHz)	Peak (dBuV/m)	Height (cm)	Polarization	Azimuth (deg)	Reading value (dBuV/m)	Correct Factor (dB)	Margin (dB)	Limit (dBuV/m)
3000.000000	41.3	205.0	V	262.0	44.5	-3.2	32.7	74
4143.750000	41.5	300.0	H	61.0	41.7	-0.2	32.5	74
4550.000000	45.7	205.0	V	60.0	44.9	0.8	28.3	74
5598.125000	48.7	105.0	H	0.0	45.3	3.4	25.3	74
5938.125000	48.0	105.0	H	134.0	43.2	4.8	26.0	74
6920.000000	47.3	105.0	V	348.0	41.1	6.2	26.7	74

Remark: 1. Correction Factor = Antenna factor+ Insertion loss (cable loss + amplifier gain)

Frequency (MHz)	Average (dBuV/m)	Height (cm)	Polarization	Azimuth (deg)	Reading value (dBuV/m)	Correct Factor (dB)	Margin (dB)	Limit (dBuV/m)
3000.000000	27.5	205.0	V	262.0	30.7	-3.2	26.5	54
4123.750000	28.7	300.0	V	348.0	29.1	-0.4	25.3	54
4550.000000	41.5	205.0	V	60.0	40.7	0.8	12.5	54
5626.875000	36.0	105.0	H	0.0	32.6	3.4	18.0	54
6005.625000	35.3	105.0	H	134.0	30.5	4.8	18.7	54
6996.250000	34.9	205.0	H	327.0	28.4	6.5	19.1	54

Remark: 1. Correction Factor = Antenna factor+ Insertion loss (cable loss + amplifier gain)

RE 3-18GHz PK+AV_BELL SWEEP

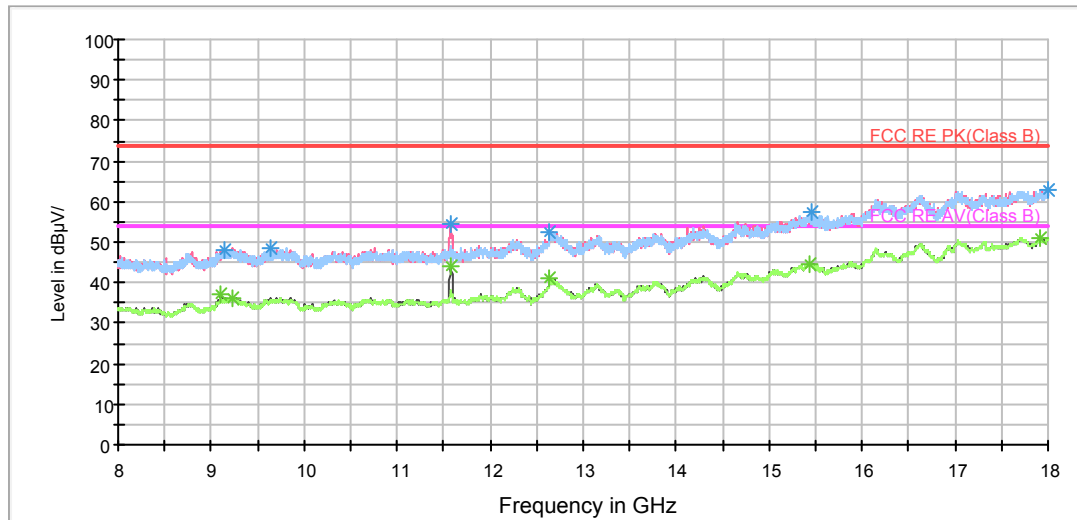

Radiates Emission from 8GHz to 18GHz

Frequency (MHz)	Peak (dBuV/m)	Height (cm)	Polarization	Azimuth (deg)	Reading value (dBuV/m)	Correct Factor (dB)	Margin (dB)	Limit (dBuV/m)
9140.000000	47.9	300.0	V	0.0	38.0	9.9	26.1	74
9633.750000	48.4	300.0	H	225.0	38.5	9.9	25.6	74
11580.000000	54.2	205.0	V	225.0	43.1	11.1	19.8	74
12635.000000	52.5	300.0	V	217.0	38.5	14.0	21.5	74
15448.750000	57.2	300.0	H	115.0	37.7	19.5	16.8	74
17997.500000	63.1	105.0	H	9.0	37.7	25.4	10.9	74

Remark: 1. Correction Factor = Antenna factor+ Insertion loss (cable loss + amplifier gain)

Frequency (MHz)	Average (dBuV/m)	Height (cm)	Polarization	Azimuth (deg)	Reading value (dBuV/m)	Correct Factor (dB)	Margin (dB)	Limit (dBuV/m)
9100.000000	37.4	105.0	V	337.0	27.9	9.5	16.6	54
9235.000000	36.4	105.0	H	89.0	26.5	9.9	17.6	54
11573.750000	43.9	205.0	V	225.0	32.9	11.0	10.1	54
12640.000000	40.9	300.0	V	163.0	26.3	14.6	13.1	54
15438.750000	44.7	105.0	H	36.0	25.2	19.5	9.3	54
17920.000000	51.1	105.0	H	0.0	25.3	25.8	2.9	54

Remark: 1. Correction Factor = Antenna factor+ Insertion loss (cable loss + amplifier gain)

RE 18-26.5GHz PK+AV

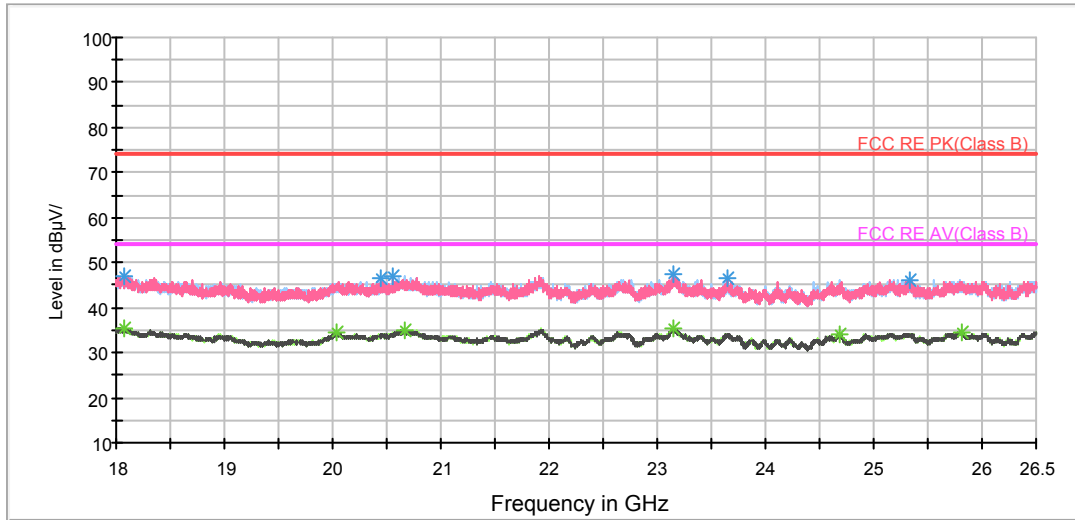

Radiates Emission from 18GHz to 26.5GHz

Frequency (MHz)	Peak (dBuV/m)	Polarization	Azimuth (deg)	Reading value (dBuV/m)	Correct Factor (dB)	Margin (dB)	Limit (dBuV/m)
18072.250000	47.1	V	111.0	49.2	-2.1	26.9	74.0
20450.125000	46.5	H	196.0	52.6	-6.1	27.5	74.0
20553.187500	46.9	V	80.0	53.2	-6.3	27.1	74.0
23139.312500	47.3	V	238.0	53.4	-6.1	26.7	74.0
23640.812500	46.3	V	111.0	52.2	-5.9	27.7	74.0
25334.437500	46.1	H	270.0	51.9	-5.8	27.9	74.0

Remark: 1. Correction Factor = Antenna factor+ Insertion loss (cable loss + amplifier gain)

Frequency (MHz)	Average (dBuV/m)	Polarization	Azimuth (deg)	Reading value (dBuV/m)	Correct Factor (dB)	Margin (dB)	Limit (dBuV/m)
18068.000000	35.4	V	80.0	37.5	-2.1	18.6	54.0
20042.125000	34.4	V	132.0	40.1	-5.7	19.6	54.0
20667.937500	34.8	V	0.0	41.4	-6.6	19.2	54.0
23151.000000	35.3	H	228.0	41.4	-6.1	18.7	54.0
24691.625000	34.2	H	0.0	40.2	-6.0	19.8	54.0
25817.875000	34.7	H	280.0	40.2	-5.5	19.3	54.0

Remark: 1. Correction Factor = Antenna factor+ Insertion loss (cable loss + amplifier gain)

RE 26.5-40GHz PK+AV

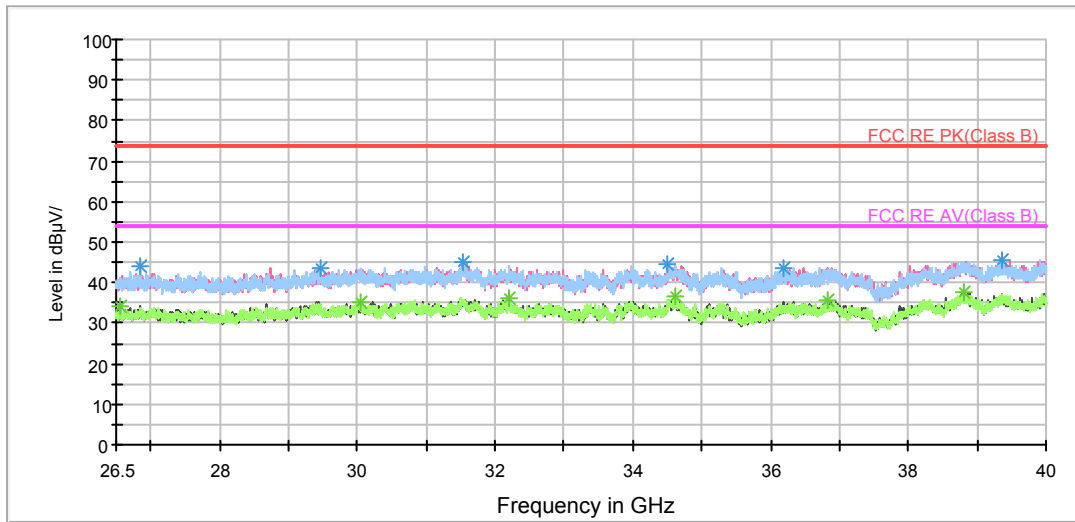

Radiates Emission from 26.5GHz to 40GHz

Frequency (MHz)	Peak (dBuV/m)	Polarization	Azimuth (deg)	Reading value (dBuV/m)	Correct Factor (dB)	Margin (dB)	Limit (dBuV/m)
26839.187500	44.0	H	227.0	44.7	-0.7	30.0	74.0
29466.625000	43.8	H	0.0	44.6	-0.8	30.2	74.0
31520.312500	45.0	V	4.0	45.5	-0.5	29.0	74.0
34513.937500	44.5	V	0.0	45.5	-1.0	29.5	74.0
36194.687500	43.5	H	207.0	43.7	-0.2	30.5	74.0
39363.812500	45.4	V	0.0	42.6	2.8	28.6	74.0

Remark: 1. Correction Factor = Antenna factor+ Insertion loss (cable loss + amplifier gain)

Frequency (MHz)	Average (dBuV/m)	Polarization	Azimuth (deg)	Reading value (dBuV/m)	Correct Factor (dB)	Margin (dB)	Limit (dBuV/m)
26570.875000	34.3	V	72.0	34.7	-0.4	19.7	54.0
30043.750000	35.3	H	76.0	35.7	-0.4	18.7	54.0
32200.375000	36.4	V	344.0	36.9	-0.5	17.6	54.0
34610.125000	36.5	H	299.0	37.5	-1.0	17.5	54.0
36819.062500	35.7	H	104.0	35.8	-0.1	18.3	54.0
38806.937500	37.6	V	327.0	34.8	2.8	16.4	54.0

Remark: 1. Correction Factor = Antenna factor+ Insertion loss (cable loss + amplifier gain)

5840MHz

FCC RE 0.03-1GHz QP Class B

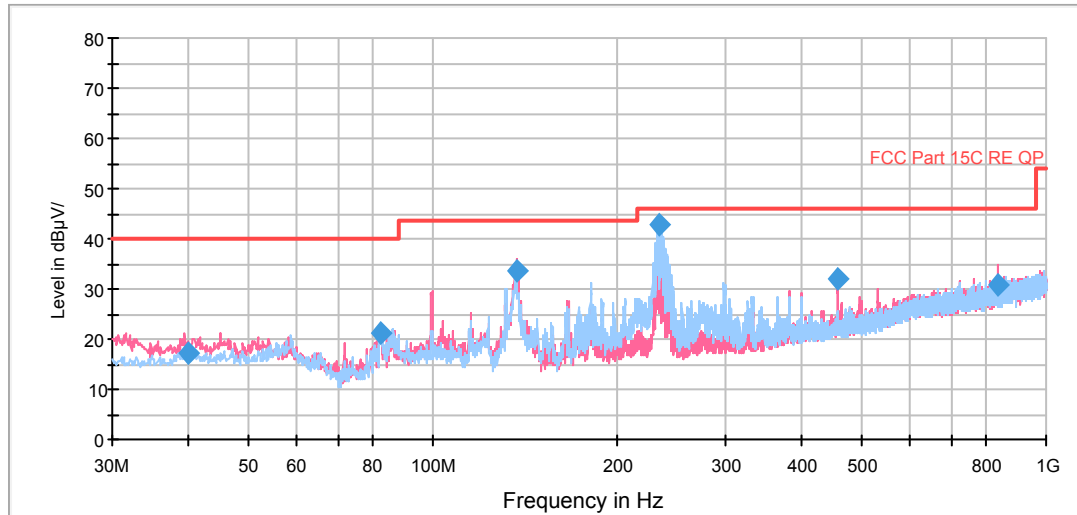

Radiates Emission from 30MHz to 1GHz

Frequency (MHz)	Quasi-Peak (dBuV/m)	Height (cm)	Polarization	Azimuth (deg)	Reading value (dBuV/m)	Correct Factor (dB)	Margin (dB)	Limit (dBuV/m)
39.857500	17.1	100.0	V	226.0	3.9	13.2	22.9	40.0
82.060000	21.1	100.0	H	330.0	11.9	9.2	18.9	40.0
136.821250	33.5	100.0	V	37.0	24.4	9.1	10.0	43.5
233.816250	42.8	125.0	H	235.0	29.0	13.8	3.2	46.0
458.372500	32.0	100.0	V	198.0	13.0	19.0	14.0	46.0
837.122500	30.6	125.0	V	169.0	4.8	25.8	15.4	46.0

- Remark: 1. Quasi-Peak = Reading value + Correction factor
 2. Correction Factor = Antenna factor+ Insertion loss(cable loss+amplifier gain)
 3. Margin = Limit – Quasi-Peak

RE 1G-3GHz PK+AV

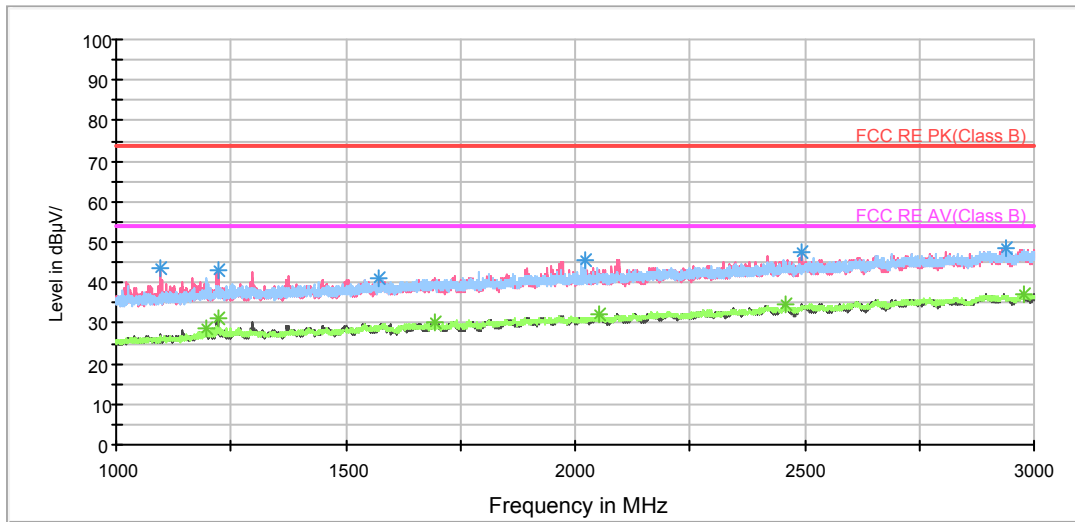

Radiates Emission from 1GHz to 3GHz

Frequency (MHz)	Peak (dBuV/m)	Height (cm)	Polarization	Azimuth (deg)	Reading value (dBuV/m)	Correct Factor (dB)	Margin (dB)	Limit (dBuV/m)
1096.750000	43.4	100.0	V	212.0	52.3	-8.9	30.6	74
1222.500000	43.2	100.0	V	229.0	51.0	-7.8	30.8	74
1574.000000	41.1	100.0	V	265.0	47.5	-6.4	32.9	74
2021.250000	45.5	100.0	H	244.0	49.1	-3.6	28.5	74
2495.500000	47.4	100.0	V	229.0	47.3	0.1	26.6	74
2937.750000	48.4	100.0	V	96.0	46.5	1.9	25.6	74

Remark: 1. Correction Factor = Antenna factor+ Insertion loss (cable loss + amplifier gain)

Frequency (MHz)	Average (dBuV/m)	Height (cm)	Polarization	Azimuth (deg)	Reading value (dBuV/m)	Correct Factor (dB)	Margin (dB)	Limit (dBuV/m)
1196.500000	28.8	100.0	H	222.0	37.0	-8.2	25.2	54
1221.500000	31.3	100.0	V	229.0	39.1	-7.8	22.7	54
1696.000000	30.1	100.0	V	247.0	35.1	-5.0	23.9	54
2052.750000	32.0	100.0	V	229.0	35.2	-3.2	22.0	54
2457.000000	34.5	100.0	V	335.0	35.0	-0.5	19.5	54
2980.000000	37.1	100.0	V	0.0	34.9	2.2	16.9	54

Remark: 1. Correction Factor = Antenna factor+ Insertion loss (cable loss + amplifier gain)

RE 3-18GHz PK+AV_BELL SWEEP

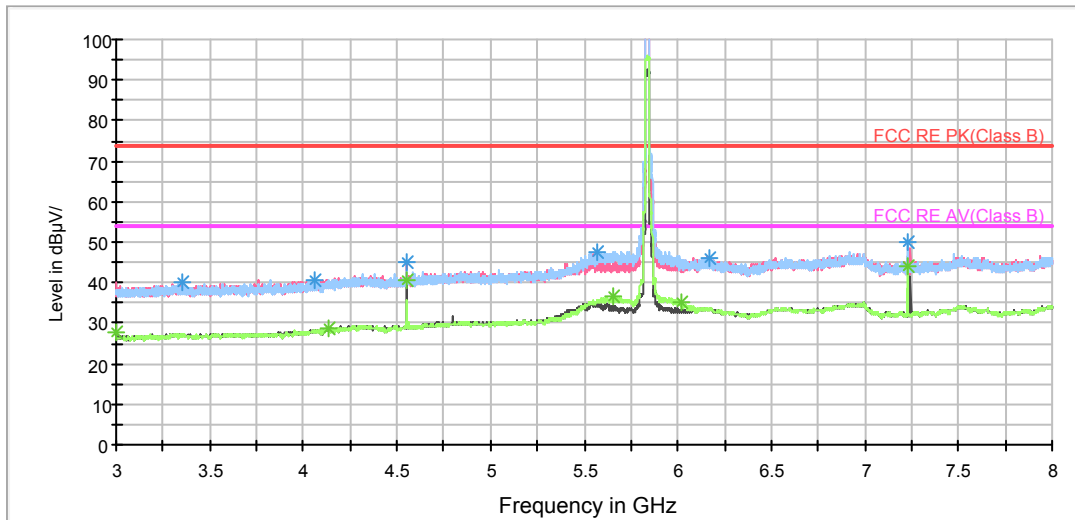

Note: The signal beyond the limit is carrier.
Radiates Emission from 3GHz to 8GHz

Frequency (MHz)	Peak (dBuV/m)	Height (cm)	Polarization	Azimuth (deg)	Reading value (dBuV/m)	Correct Factor (dB)	Margin (dB)	Limit (dBuV/m)
3357.500000	40.2	105.0	H	0.0	42.5	-2.3	33.8	74
4057.500000	40.8	205.0	H	331.0	41.9	-1.1	33.2	74
4549.375000	45.0	205.0	V	58.0	44.2	0.8	29.0	74
5565.625000	47.7	105.0	H	0.0	44.4	3.3	26.3	74
6166.875000	45.8	300.0	H	0.0	40.2	5.6	28.2	74
7233.125000	50.0	205.0	H	206.0	43.2	6.8	24.0	74

Remark: 1. Correction Factor = Antenna factor+ Insertion loss (cable loss + amplifier gain)

Frequency (MHz)	Average (dBuV/m)	Height (cm)	Polarization	Azimuth (deg)	Reading value (dBuV/m)	Correct Factor (dB)	Margin (dB)	Limit (dBuV/m)
3000.000000	27.7	205.0	V	261.0	30.9	-3.2	26.3	54
4136.250000	28.7	105.0	H	61.0	29.0	-0.3	25.3	54
4550.000000	40.8	205.0	V	58.0	40.0	0.8	13.2	54
5658.750000	36.6	105.0	H	0.0	33.1	3.5	17.4	54
6018.125000	35.0	105.0	H	135.0	30.3	4.7	19.0	54
7233.125000	44.3	205.0	H	206.0	37.5	6.8	9.7	54

Remark: 1. Correction Factor = Antenna factor+ Insertion loss (cable loss + amplifier gain)

RE 3-18GHz PK+AV_BELL SWEEP

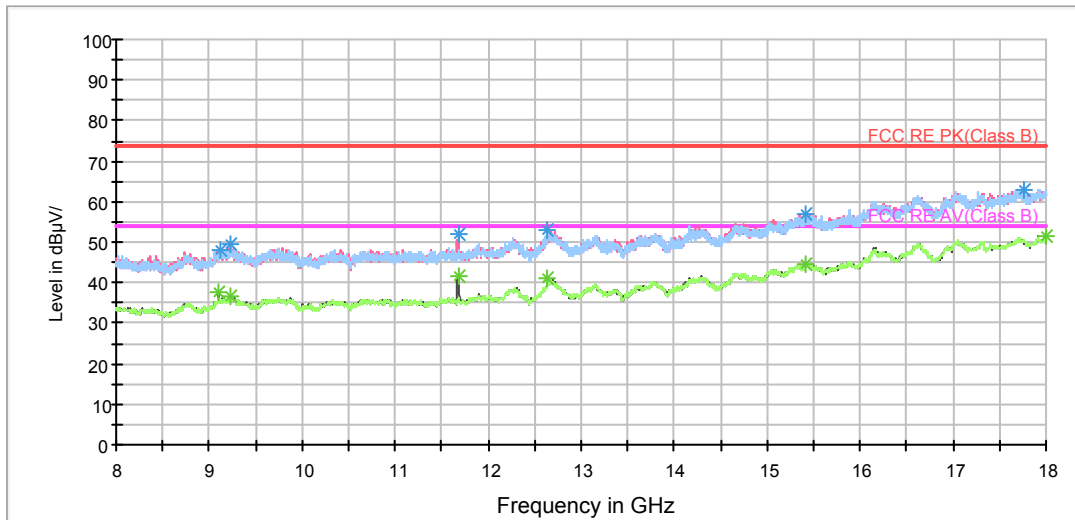

Radiates Emission from 8GHz to 18GHz

Frequency (MHz)	Peak (dBuV/m)	Height (cm)	Polarization	Azimuth (deg)	Reading value (dBuV/m)	Correct Factor (dB)	Margin (dB)	Limit (dBuV/m)
9130.000000	47.9	300.0	V	330.0	37.9	10.0	26.1	74
9238.750000	49.6	300.0	H	254.0	39.7	9.9	24.4	74
11676.250000	51.8	205.0	V	224.0	40.4	11.4	22.2	74
12638.750000	53.0	300.0	H	91.0	38.6	14.4	21.0	74
15420.000000	57.1	205.0	H	0.0	37.7	19.4	16.9	74
17753.750000	63.1	205.0	V	252.0	38.9	24.2	10.9	74

Remark: 1. Correction Factor = Antenna factor+ Insertion loss (cable loss + amplifier gain)

Frequency (MHz)	Average (dBuV/m)	Height (cm)	Polarization	Azimuth (deg)	Reading value (dBuV/m)	Correct Factor (dB)	Margin (dB)	Limit (dBuV/m)
9100.000000	37.5	205.0	V	90.0	28.0	9.5	16.5	54
9218.750000	36.4	105.0	V	0.0	26.5	9.9	17.6	54
11681.250000	41.3	205.0	V	224.0	29.9	11.4	12.7	54
12640.000000	40.9	205.0	V	0.0	26.3	14.6	13.1	54
15422.500000	44.7	300.0	V	0.0	25.3	19.4	9.3	54
17998.750000	51.3	300.0	V	249.0	25.9	25.4	2.7	54

Remark: 1. Correction Factor = Antenna factor+ Insertion loss (cable loss + amplifier gain)

RE 18-26.5GHz PK+AV

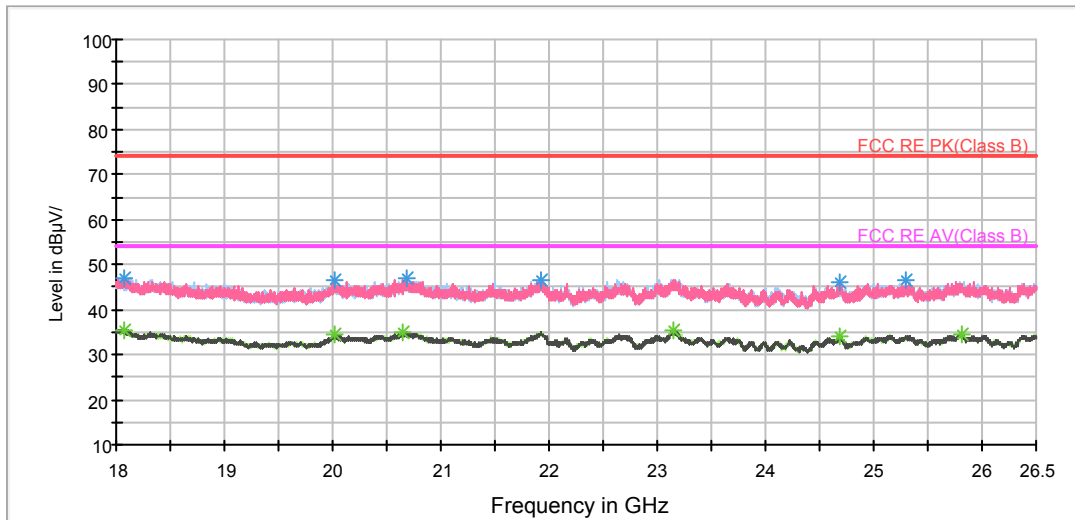

Radiates Emission from 18GHz to 26.5GHz

Frequency (MHz)	Peak (dBuV/m)	Polarization	Azimuth (deg)	Reading value (dBuV/m)	Correct Factor (dB)	Margin (dB)	Limit (dBuV/m)
18079.687500	46.9	V	185.0	49.0	-2.1	27.1	74.0
20025.125000	46.3	V	68.0	52.0	-5.7	27.7	74.0
20683.875000	47.1	V	0.0	53.7	-6.6	26.9	74.0
21918.500000	46.7	V	15.0	54.7	-8.0	27.3	74.0
24692.687500	46.1	V	68.0	52.1	-6.0	27.9	74.0
25300.437500	46.6	H	302.0	52.4	-5.8	27.4	74.0

Remark: 1. Correction Factor = Antenna factor+ Insertion loss (cable loss + amplifier gain)

Frequency (MHz)	Average (dBuV/m)	Polarization	Azimuth (deg)	Reading value (dBuV/m)	Correct Factor (dB)	Margin (dB)	Limit (dBuV/m)
18069.062500	35.6	H	79.0	37.7	-2.1	18.4	54.0
20027.250000	34.4	H	334.0	40.1	-5.7	19.6	54.0
20652.000000	35.0	V	306.0	41.6	-6.6	19.0	54.0
23153.125000	35.5	H	0.0	41.6	-6.1	18.5	54.0
24683.125000	33.9	H	112.0	39.9	-6.0	20.1	54.0
25808.312500	34.5	V	26.0	40.0	-5.5	19.5	54.0

Remark: 1. Correction Factor = Antenna factor+ Insertion loss (cable loss + amplifier gain)

RE 26.5-40GHz PK+AV

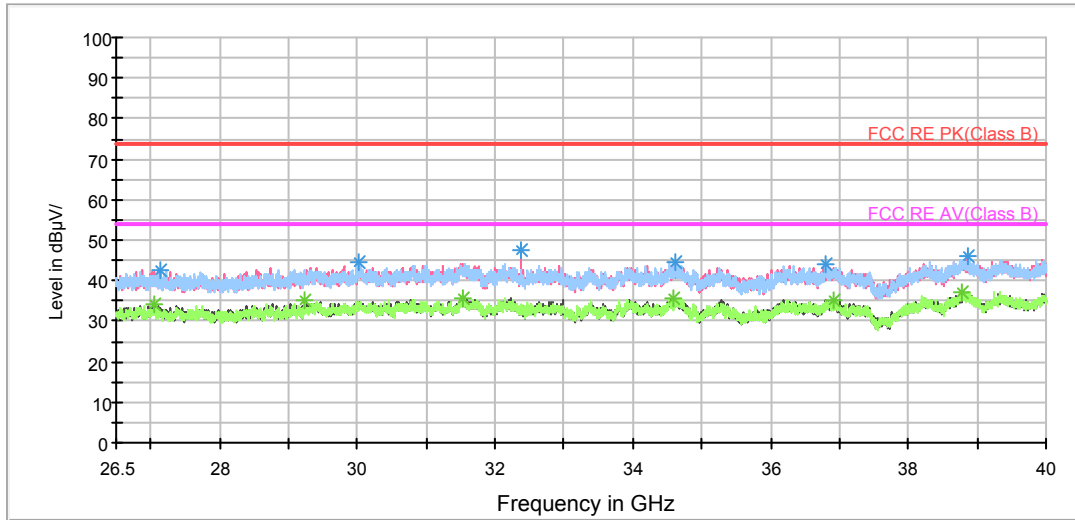

Radiates Emission from 26.5GHz to 40GHz

Frequency (MHz)	Peak (dBuV/m)	Polarization	Azimuth (deg)	Reading value (dBuV/m)	Correct Factor (dB)	Margin (dB)	Limit (dBuV/m)
27132.812500	42.8	V	0.0	43.8	-1.0	31.2	74.0
30023.500000	44.5	H	49.0	44.9	-0.4	29.5	74.0
32367.437500	47.4	V	314.0	48.0	-0.6	26.6	74.0
34611.812500	44.6	H	0.0	45.6	-1.0	29.4	74.0
36808.937500	43.8	H	58.0	43.9	-0.1	30.2	74.0
38877.812500	46.0	H	171.0	43.1	2.9	28.0	74.0

Remark: 1. Correction Factor = Antenna factor+ Insertion loss (cable loss + amplifier gain)

Frequency (MHz)	Average (dBuV/m)	Polarization	Azimuth (deg)	Reading value (dBuV/m)	Correct Factor (dB)	Margin (dB)	Limit (dBuV/m)
27051.812500	34.3	V	265.0	35.3	-1.0	19.7	54.0
29238.812500	35.1	V	209.0	36.1	-1.0	18.9	54.0
31545.625000	35.9	H	105.0	36.4	-0.5	18.1	54.0
34601.687500	35.7	V	286.0	36.7	-1.0	18.3	54.0
36920.312500	35.2	V	170.0	35.3	-0.1	18.8	54.0
38786.687500	37.3	V	189.0	34.6	2.7	16.7	54.0

Remark: 1. Correction Factor = Antenna factor+ Insertion loss (cable loss + amplifier gain)

5.6. Conducted spurious emissions at antenna port

Ambient condition

Temperature	Relative humidity	Pressure
23°C ~25°C	45%~50%	101.5kPa

Methods of Measurement

The EUT was connected to the spectrum analyzer through an external attenuator (20dB) and a known loss cable. Set RBW = 1MHz, VBW =3MHz for the9kHz to 10th harmonic

The conducted is measured at each antenna port. The measured results at the various antenna ports are then summed mathematically.

Test Setup

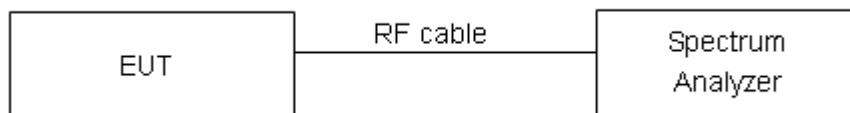

Limits

FCC §407 (b) Undesirable emission limits. Except as shown in paragraph (b)(7) of this section, the maximum emissions outside of the frequency bands of operation shall be attenuated in accordance with the following limits:

(4) For transmitters operating in the 5725-5850 MHz band: All emissions shall be limited to a level of -27 dBm/MHz at 75 MHz or more above or below the band edge increasing linearly to 10 dBm/MHz at 25 MHz above or below the band edge, and from 25 MHz above or below the band edge increasing linearly to a level of 15.6 dBm/MHz at 5 MHz above or below the band edge, and from 5 MHz above or below the band edge increasing linearly to a level of 27 dBm/MHz at the band edge.

Note: the following formula is used to convert the EIRP to field strength

§1、 $E[\text{dB}\mu\text{V}/\text{m}] = \text{EIRP}[\text{dBm}] - 20 \log(d[\text{meters}]) + 104.77$, where E = field strength and

d = distance at which field strength limit is specified in the rules;

§2、 $E[\text{dB}\mu\text{V}/\text{m}] = \text{EIRP}[\text{dBm}] + 95.2$, for d = 3 meters

(7)Unwanted spurious emissions fallen in restricted bands per FCC Part15.205 shall comply with the general field strength limits set forth in § 15.209 as below table.

Frequency of emission (MHz)	Field strength(uV/m)	Field strength(dBuV/m)
0.009–0.490	2400/F(kHz)	/
0.490–1.705	24000/F(kHz)	/
1.705–30.0	30	/
30-88	100	40
88-216	150	43.5
216-960	200	46
Above960	500	54

MHz	MHz	MHz	GHz
0.090 - 0.110	16.42 - 16.423	399.9 - 410	4.5 - 5.15
¹ 0.495 - 0.505	16.69475 - 16.69525	608 - 614	5.35 - 5.46
2.1735 - 2.1905	16.80425 - 16.80475	960 - 1240	7.25 - 7.75
4.125 - 4.128	25.5 - 25.67	1300 - 1427	8.025 - 8.5
4.17725 - 4.17775	37.5 - 38.25	1435 - 1626.5	9.0 - 9.2
4.20725 - 4.20775	73 - 74.6	1645.5 - 1646.5	9.3 - 9.5
6.215 - 6.218	74.8 - 75.2	1660 - 1710	10.6 - 12.7
6.26775 - 6.26825	108 - 121.94	1718.8 - 1722.2	13.25 - 13.4
6.31175 - 6.31225	123 - 138	2200 - 2300	14.47 - 14.5
8.291 - 8.294	149.9 - 150.05	2310 - 2390	15.35 - 16.2
8.362 - 8.366	156.52475 - 156.52525	2483.5 - 2500	17.7 - 21.4
8.37625 - 8.38675	156.7 - 156.9	2690 - 2900	22.01 - 23.12
8.41425 - 8.41475	162.0125 - 167.17	3260 - 3267	23.6 - 24.0
12.29 - 12.293	167.72 - 173.2	3332 - 3339	31.2 - 31.8
12.51975 - 12.52025	240 - 285	3345.8 - 3358	36.43 - 36.5
12.57675 - 12.57725	322 - 335.4	3600 - 4400	(²)
13.36 - 13.41			

Note: Please refer to the following plots:

A value representative of an upper bound on out-of-band antenna gain (in dBi) shall be added to the measured antenna-port conducted emission power to compute EIRP within the specified measurement bandwidth. The upper bound on antenna gain for a device with a single RF output shall be selected as the maximum in-band gain of the antenna across all operating bands or 2 dBi, whichever is greater

Test result

The signal beyond the limit is carrier.

Sweep the whole frequency band through the range from 9kHz to the 10th harmonic of the carrier, and 9kHz-30MHz, the emissions more than 20 dB below the permissible value are not reported.

All spurious emissions at the antenna port is lower than -55dbm, so the total emission is lower than -39dbm, antenna gain is 16dbi, so compliance the requirements

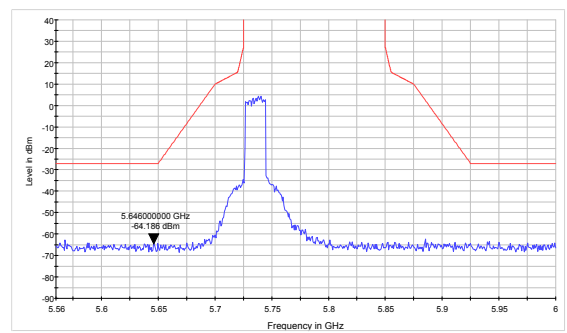
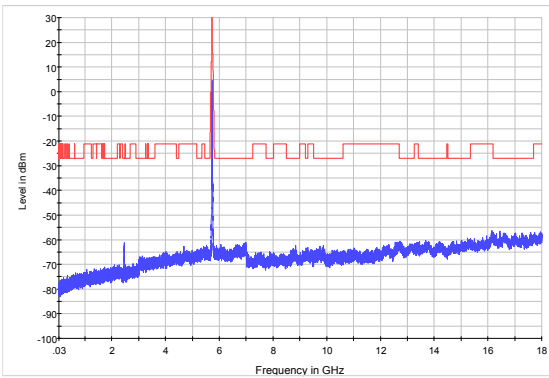

Frequency 5735MHz, 30M-18GHz

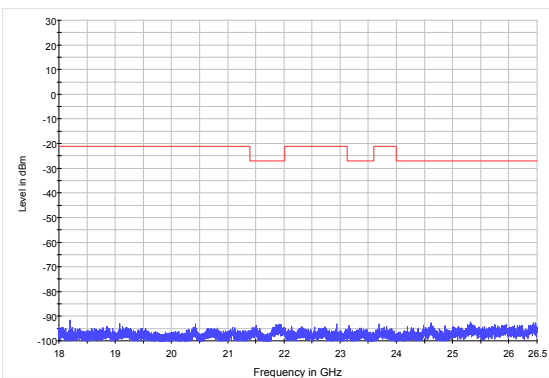

Frequency 5735MHz, 18G-26.5GHz

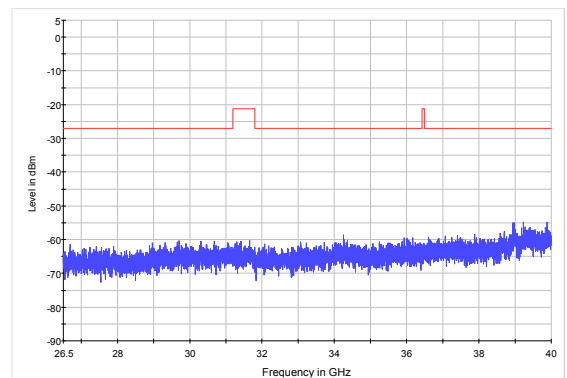

Frequency 5735MHz, 26.5G-40GHz

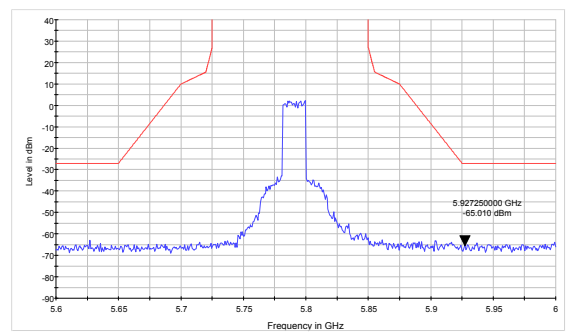
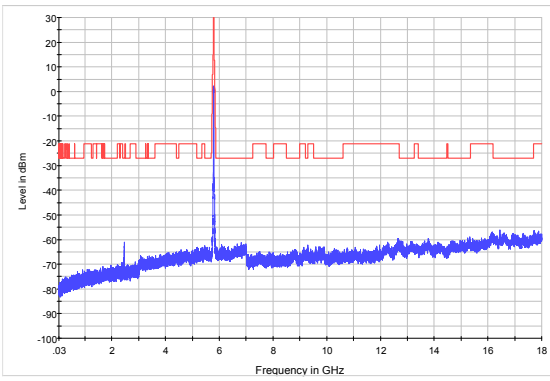

Frequency 5790MHz, 30M-18GHz

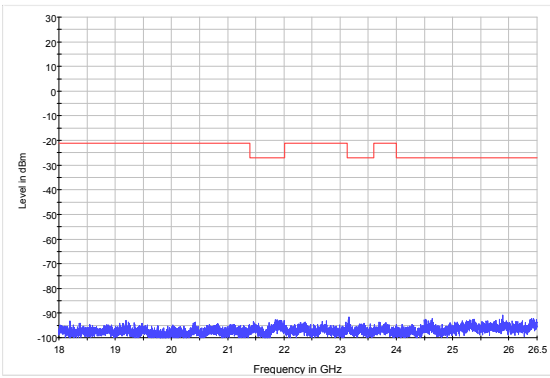

Frequency 5790MHz, 18G-26.5GHz

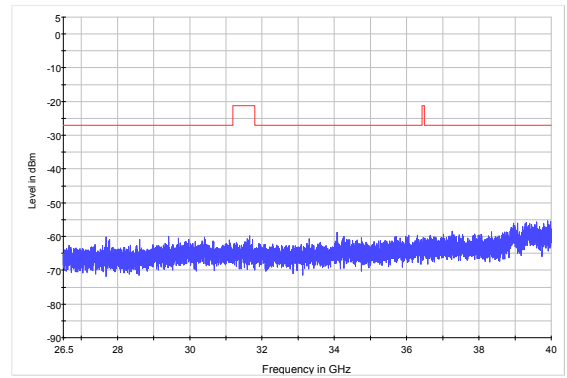

Frequency 5790MHz, 26.5G-40GHz

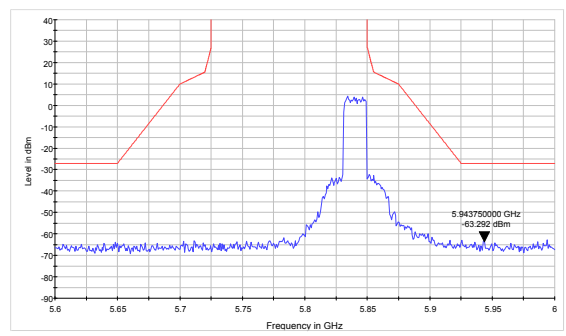
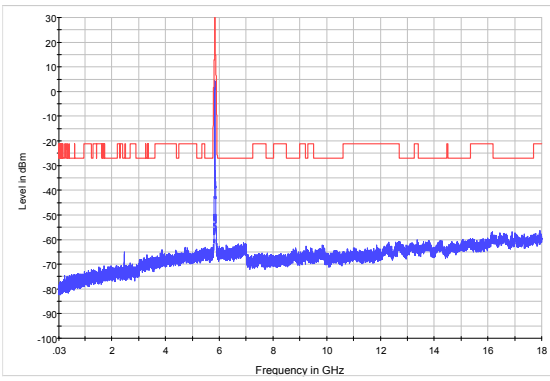

Frequency 5840MHz, 30M-18GHz

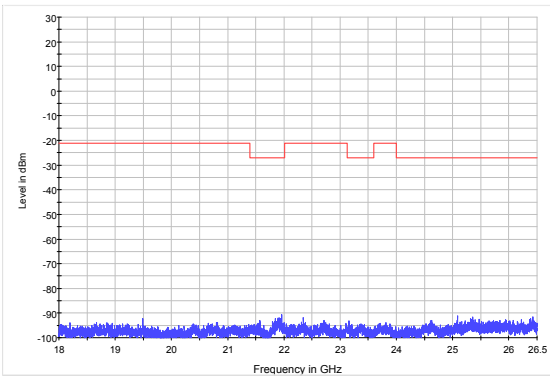

Frequency 5840MHz, 18G-26.5GHz

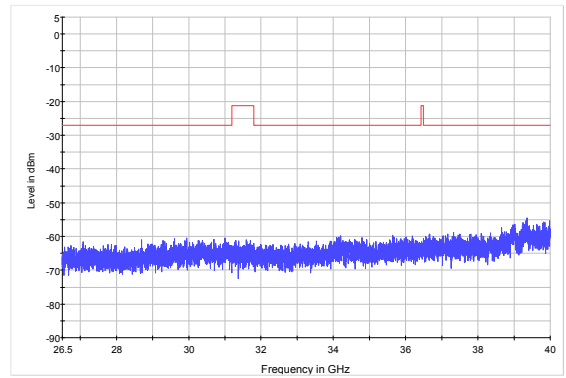

Frequency 5840MHz, 26.5G-40GHz

5.7. Conducted Emission

Ambient condition

Temperature	Relative humidity	Pressure
23°C ~25°C	45%~50%	101.5kPa

Methods of Measurement

The EUT IS placed on a non-metallic table of 80cm height above the horizontal metal reference ground plane. During the test, the EUT was operating in its typical mode. The test method is according to ANSI C63.10-2013.Connect the AC power line of the EUT to the LISN Use EMI receiver to detect the average and Quasi-peak value. RBW is set to 9kHz, VBW is set to 30kHz The measurement result should include both L line and N line.

The test is in transmitting mode.

Test Setup

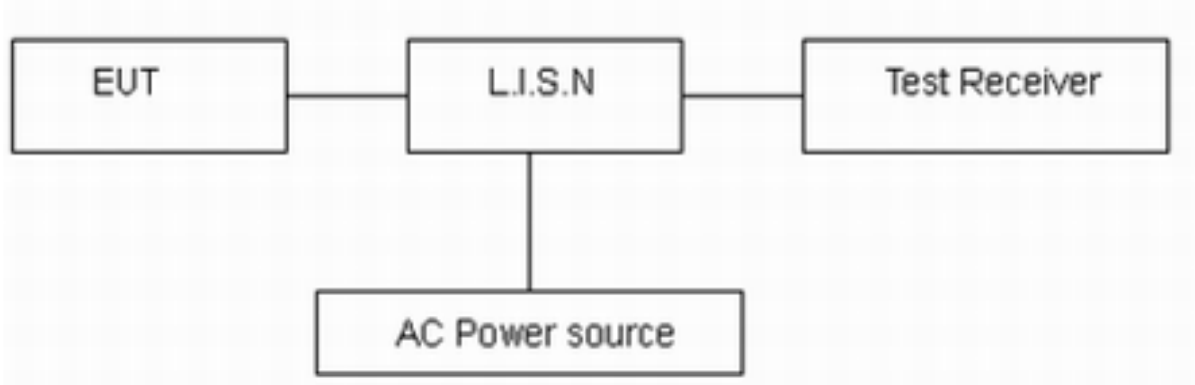

Note: AC Power source is used to change the voltage 110V/60Hz.

Limits

Frequency (MHz)	Conducted Limits(dBμV)	
	Quasi-peak	Average
0.15 - 0.5	66 to 56 *	56 to 46*
0.5 - 5	56	46
5 - 30	60	50

*: Decreases with the logarithm of the frequency.

Measurement Uncertainty

The assessed measurement uncertainty to ensure 95% confidence level for the normal distribution is with the coverage factor $k = 1.96$, $U = 2.69$ dB.

Test Results:

Following plots, Blue trace uses the peak detection and Green trace uses the average detection.

Frequency 5735MHz, L Line

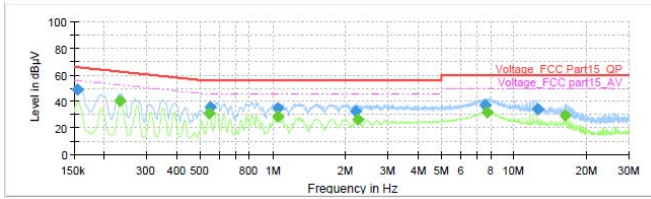

Final Result

Frequency (MHz)	QuasiPeak (dBµV)	Average (dBµV)	Limit (dBµV)	Margin (dB)	Meas. Time (ms)	Bandwidth (kHz)	Line	Filter	Corr. (dB)
0.154500	48.54	---	65.75	17.21	1000.0	9.000	L1	ON	19.1
0.233250	---	40.26	52.33	12.07	1000.0	9.000	L1	ON	19.1
0.546000	---	30.99	46.00	15.01	1000.0	9.000	L1	ON	19.2
0.548250	35.49	---	56.00	20.51	1000.0	9.000	L1	ON	19.3
1.043250	34.76	---	56.00	21.24	1000.0	9.000	L1	ON	19.2
1.052250	---	28.59	46.00	17.41	1000.0	9.000	L1	ON	19.2
2.202000	32.30	---	56.00	23.70	1000.0	9.000	L1	ON	19.1
2.247000	---	26.16	46.00	19.84	1000.0	9.000	L1	ON	19.1
7.557000	36.87	---	60.00	23.13	1000.0	9.000	L1	ON	19.2
7.728000	---	31.83	50.00	18.17	1000.0	9.000	L1	ON	19.2
12.468750	34.43	---	60.00	25.57	1000.0	9.000	L1	ON	19.4
16.257750	---	29.77	50.00	20.23	1000.0	9.000	L1	ON	19.5

Frequency 5735MHz, N Line

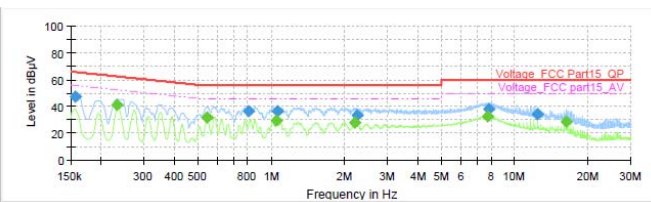

Final Result

Frequency (MHz)	QuasiPeak (dBµV)	Average (dBµV)	Limit (dBµV)	Margin (dB)	Meas. Time (ms)	Bandwidth (kHz)	Line	Filter	Corr. (dB)
0.156750	47.57	---	65.63	18.07	1000.0	9.000	L1	ON	19.1
0.233250	---	41.19	52.33	11.15	1000.0	9.000	L1	ON	19.1
0.546000	---	31.98	46.00	14.02	1000.0	9.000	L1	ON	19.2
0.809250	36.13	---	56.00	19.87	1000.0	9.000	L1	ON	19.2
1.050000	---	29.40	46.00	16.60	1000.0	9.000	L1	ON	19.2
1.059000	36.20	---	56.00	19.80	1000.0	9.000	L1	ON	19.2
2.215500	---	27.55	46.00	18.45	1000.0	9.000	L1	ON	19.1
2.253750	33.42	---	56.00	22.58	1000.0	9.000	L1	ON	19.1
7.743750	---	32.68	50.00	17.32	1000.0	9.000	L1	ON	19.2
7.791000	38.05	---	60.00	21.95	1000.0	9.000	L1	ON	19.2
12.381000	33.91	---	60.00	26.09	1000.0	9.000	L1	ON	19.4
16.257750	---	28.84	50.00	21.16	1000.0	9.000	L1	ON	19.5

Frequency 5790MHz, L Line

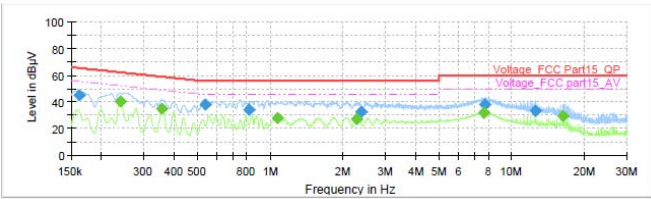

Final Result

Frequency (MHz)	QuasiPeak (dBµV)	Average (dBµV)	Limit (dBµV)	Margin (dB)	Meas. Time (ms)	Bandwidth (kHz)	Line	Filter	Corr. (dB)
0.161250	45.16	---	65.40	20.24	1000.0	9.000	L1	ON	19.1
0.240000	---	39.96	52.10	12.13	1000.0	9.000	L1	ON	19.1
0.357000	---	35.00	48.80	13.80	1000.0	9.000	L1	ON	19.2
0.537000	38.01	---	56.00	17.99	1000.0	9.000	L1	ON	19.2
0.816000	34.09	---	56.00	21.91	1000.0	9.000	L1	ON	19.2
1.074750	---	28.20	46.00	17.80	1000.0	9.000	L1	ON	19.2
2.280750	---	27.29	46.00	18.71	1000.0	9.000	L1	ON	19.1
2.375250	32.47	---	56.00	23.53	1000.0	9.000	L1	ON	19.0
7.662750	---	31.80	50.00	18.20	1000.0	9.000	L1	ON	19.2
7.752750	37.77	---	60.00	22.23	1000.0	9.000	L1	ON	19.2
12.462000	32.96	---	60.00	27.04	1000.0	9.000	L1	ON	19.4
16.257750	---	29.63	50.00	20.37	1000.0	9.000	L1	ON	19.5

Frequency 5790MHz, N Line

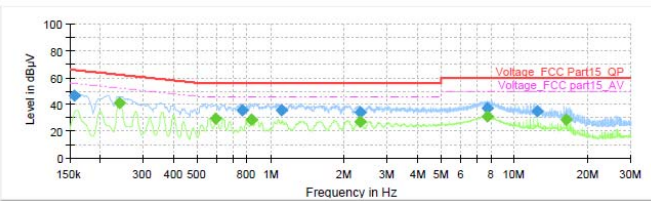

Final Result

Frequency (MHz)	QuasiPeak (dBµV)	Average (dBµV)	Limit (dBµV)	Margin (dB)	Meas. Time (ms)	Bandwidth (kHz)	Line	Filter	Corr. (dB)
0.156750	46.37	---	65.63	19.27	1000.0	9.000	N	ON	19.1
0.240000	---	40.77	52.10	11.33	1000.0	9.000	N	ON	19.1
0.595500	---	29.15	46.00	16.85	1000.0	9.000	N	ON	19.3
0.759750	35.42	---	56.00	20.58	1000.0	9.000	N	ON	19.2
0.836250	---	29.04	46.00	16.96	1000.0	9.000	N	ON	19.2
1.108500	35.39	---	56.00	20.61	1000.0	9.000	N	ON	19.2
2.323500	---	27.22	46.00	18.78	1000.0	9.000	N	ON	19.0
2.325750	33.89	---	56.00	22.11	1000.0	9.000	N	ON	19.0
7.728000	---	31.01	50.00	18.99	1000.0	9.000	N	ON	19.2
7.764000	37.06	---	60.00	22.94	1000.0	9.000	N	ON	19.2
12.383250	34.61	---	60.00	25.39	1000.0	9.000	N	ON	19.4
16.257750	---	28.80	50.00	21.20	1000.0	9.000	N	ON	19.4

Frequency 5840MHz, L Line

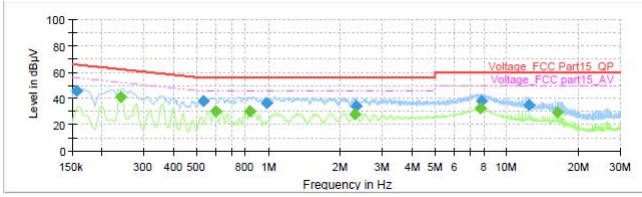

Final Result

Frequency (MHz)	QuasiPeak (dBµV)	Average (dBµV)	Limit (dBµV)	Margin (dB)	Meas. Time (ms)	Bandwidth (kHz)	Line	Filter	Corr. (dB)
0.156750	45.65	---	65.63	19.99	1000.0	9.000	L1	ON	19.1
0.240000	---	41.22	52.10	10.88	1000.0	9.000	L1	ON	19.1
0.534750	38.03	---	56.00	17.97	1000.0	9.000	L1	ON	19.2
0.597750	---	30.48	46.00	15.52	1000.0	9.000	L1	ON	19.3
0.836250	---	30.16	46.00	15.84	1000.0	9.000	L1	ON	19.2
0.980250	36.41	---	56.00	19.59	1000.0	9.000	L1	ON	19.2
2.305500	---	28.21	46.00	17.79	1000.0	9.000	L1	ON	19.0
2.337000	34.06	---	56.00	21.94	1000.0	9.000	L1	ON	19.0
7.773000	---	32.30	50.00	17.70	1000.0	9.000	L1	ON	19.2
7.804500	38.11	---	60.00	21.89	1000.0	9.000	L1	ON	19.2
12.385500	34.97	---	60.00	25.03	1000.0	9.000	L1	ON	19.4
16.257750	---	29.29	50.00	20.71	1000.0	9.000	L1	ON	19.5

Frequency 5840MHz, N Line

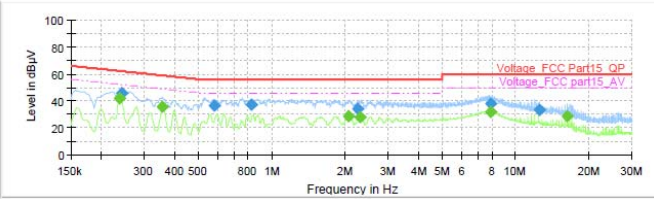

Final Result

Frequency (MHz)	QuasiPeak (dBµV)	Average (dBµV)	Limit (dBµV)	Margin (dB)	Meas. Time (ms)	Bandwidth (kHz)	Line	Filter	Corr. (dB)
0.237750	---	41.74	52.17	10.43	1000.0	9.000	N	ON	19.1
0.242250	45.72	---	62.02	16.30	1000.0	9.000	N	ON	19.1
0.357000	---	36.04	48.80	12.76	1000.0	9.000	N	ON	19.2
0.584250	36.82	---	56.00	19.18	1000.0	9.000	N	ON	19.3
0.827250	37.47	---	56.00	18.53	1000.0	9.000	N	ON	19.2
2.069250	---	28.56	46.00	17.44	1000.0	9.000	N	ON	19.1
2.251500	34.05	---	56.00	21.95	1000.0	9.000	N	ON	19.1
2.292000	---	28.11	46.00	17.89	1000.0	9.000	N	ON	19.0
7.901250	---	37.79	60.00	22.21	1000.0	9.000	N	ON	19.2
7.910250	---	31.97	50.00	18.03	1000.0	9.000	N	ON	19.2
12.468500	33.60	---	60.00	26.40	1000.0	9.000	N	ON	19.4
16.257750	---	28.60	50.00	21.40	1000.0	9.000	N	ON	19.4

6. Main Test Instruments

Name	Type	Manufacturer	Serial Number	Calibration Date	Expiration Time
Spectrum Analyzer	FSV30	R&S	100815	2016-12-16	2017-12-15
EMI Test Receiver	ESCI	R&S	100948	2016-06-01	2017-05-31
Loop Antenna	FMZB1519	SCHWARZBECK	1519-047	2017-02-28	2020-02-27
TRILOG Broadband Antenna	VULB 9163	Schwarzbeck	9163-201	2014-12-06	2017-12-05
Double Ridged Waveguide Horn Antenna	HF907	R&S	100126	2014-12-06	2017-12-05
Standard Gain Horn	3160-09	ETS-Lindgren	00102644	2015-01-30	2018-01-29
EMI Test Receiver	ESCS30	R&S	100138	2016-12-16	2017-12-15
LISN	ENV216	R&S	101171	2016-12-16	2019-12-15
Spectrum Analyzer	N9010A	Agilent	MY47191109	2016-05-21	2017-05-20
RF Cable	SMA 15cm	Agilent	0001	2017-02-06	2017-08-05

*****END OF REPORT *****

ANNEX A: EUT Appearance and Test Setup

A.1 EUT Appearance



a: EUT



b: Adapter

Picture 1 EUT and Accessory

A.2 Test Setup

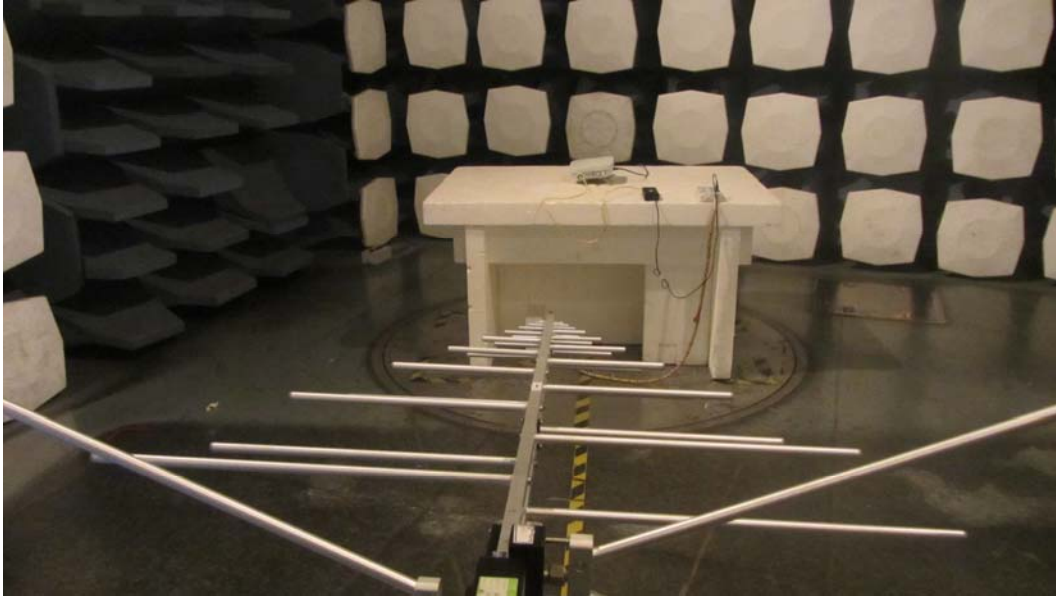

30MHz-1GHz

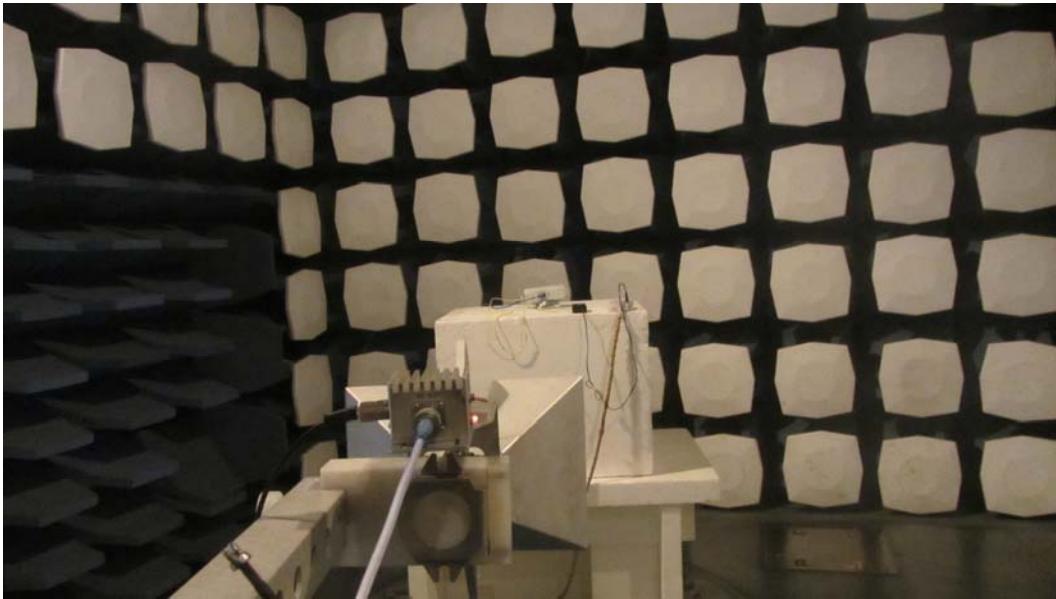

Above 1GHz

Picture 2 Radiated Emission Test Setup



Picture 3 Conducted Emission Test Setup