



# **FCC&IC RF Test Report**

**Product Name: Mobile WiFi**

**Model Number: UMG587/E587u-5**

**Report No: SYBH(Z-RF)022092011-2002**

**FCC ID: QISE587U-5**

**IC ID: 6369A-E587U5**

**Reliability Laboratory of Huawei Technologies Co., Ltd.**

Huawei Base, Bantian, Longgang District, Shenzhen 518129, P.R. China

Tel: +86 755 28780808 Fax: +86 755 89652518



## Notice

1. The laboratory has obtained the accreditation of China National Accreditation Service for Conformity Assessment (CNAS), and accreditation number: L0310.
2. The laboratory has been listed on the US Federal Communications Commission list of test facilities recognized to perform electromagnetic emissions measurements. The site recognition number is 97456.
3. The laboratory has been listed by industry Canada to perform electromagnetic emission measurement. The site recognition number is 6369A-2.
4. The test report is invalid if not marked with "exclusive stamp for the test report".
5. The test report is invalid if not marked with the stamps or the signatures of the persons responsible for performing, revising and approving the test report.
6. The test report is invalid if there is any evidence of erasure and/or falsification.
7. If there is any dissidence for the test report, please file objection to the test centre within 15 days from the date of receiving the test report.
8. Normally, the test report is only responsible for the samples that have undergone the test.
9. Context of the test report cannot be used partially or in full for publicity and/or promotional purposes without previous written approval of the laboratory.



## Notice 2

### Modification Information:

#### Modification Information

Modification Information	1	
	2	
	3	<i>Not Applicable!</i>
	4	
	5	
	6	
	7	



<b>REGULATION</b>	<b>FCC CFR47 Part 2: Subpart J;</b>
	<b>FCC CFR47 Part 24: Subpart E;</b>
	<b>IC RSS-Gen Issue 3</b>
	<b>IC RSS-133 Issue 5</b>
<b>START OF TEST</b>	<b>Sep.16, 2011</b>
<b>END OF TEST</b>	<b>Sep.18, 2011</b>
<b>Final Judgement:</b>	<b>Pass</b>

Approved By

Sep.22, 2011  
Date

Dai Linjun  
Name

*Dai Linjun*  
Signature

Reviewed By

Sep.22, 2011  
Date

Cousy Xu  
Name

*Cousy XU*  
Signature

Operator

Sep.22, 2011  
Date

Huang Qiuliang  
Name

*Huang Qiuliang*  
Signature



# Contents

<b>1</b>	<b><u>Summary</u></b> .....	<b>6</b>
<b>2</b>	<b><u>Product Description</u></b> .....	<b>7</b>
2.1	PRODUCTION INFORMATION .....	7
2.2	MODIFICATION INFORMATION .....	7
<b>3</b>	<b><u>Test Site Description</u></b> .....	<b>8</b>
3.1	TESTING PERIOD .....	8
3.2	GENERAL SET UP DESCRIPTION .....	8
<b>4</b>	<b><u>Product Description</u></b> .....	<b>9</b>
4.1	TECHNICAL CHARACTERISTICS.....	9
4.2	EUT IDENTIFICATION LIST.....	11
<b>5</b>	<b><u>Main Test Instruments</u></b> .....	<b>12</b>
<b>6</b>	<b><u>Transmitter Measurements</u></b> .....	<b>13</b>
6.1	EFFECTIVE ISOTROPIC RADIATED POWER OF TRANSMITTER (EIRP).....	13
6.2	CONDUCTED POWER OF TRANSMITTER .....	17
6.3	MODULATION CHARACTERISTICS.....	21
6.4	OCCUPIED BANDWIDTH.....	23
6.5	BAND EDGES COMPLIANCE .....	26
6.6	SPURIOUS EMISSION AT ANTENNA TERMINAL.....	28
6.7	RADIATED SPURIOUS EMISSIONS .....	31
6.8	RECEIVER SPURIOUS EMISSIONS .....	34
6.9	FREQUENCY STABILITY .....	36
<b>7</b>	<b><u>System Measurement Uncertainty</u></b> .....	<b>40</b>
<b>8</b>	<b><u>Appendices</u></b> .....	<b>41</b>



# 1 Summary

The table below summarizes the measurements and results for the EUT. Detailed results and descriptions are shown in the following pages.

Table 1 Summary of results

FCC Measurement Specification	IC Measurement Specification Part(s)	FCC Limits Part(s)	RSS-133Limits Part(s)	Description	Result
2.1046	RSS-Gen 4.8	24.232	6.4	Effective Isotropic radiated power of Transmitter	PASS
2.1046	RSS-Gen 4.8	24.232	6.4	Conducted Power of Transmitter	PASS
2.1047	/	/	6.2	Modulation Characteristics	PASS
2.1049	RSS-Gen 4.6	/	/	Occupied Bandwidth	PASS
2.1051	/	24.238	6.5	Band Edges Compliance	PASS
2.1051	RSS-Gen 4.9	24.238	6.5	Spurious Emission at Antenna Terminal	PASS
2.1053	RSS-Gen 4.9	24.238	6.5	Field Strength of Spurious Emissions	PASS
/	RSS-Gen4.10	/	6.6	Receiver Spurious Emissions	PASS
2.1055	RSS-Gen 4.7	24.235	6.3	Frequency Stability	PASS



## 2 Product Description

### 2.1 Production Information

#### 2.1.1 General Description

UMG587/E587u-5 is a UMTS/GSM Mobile WiFi It can be used as a WiFi Access Point, Max to 5 WiFi stations can be associating with UMG587/E587u-5 simultaneity. It also can be used as a USB modem by connecting with PC via USB cable. It supports wireless internet accessing function. The data service rate is HSUPA 5.75Mbps, and HSDPA 42Mbps. The WCDMA frequency is BAND I, BAND II, BAND V and AWS. The GPRS/EDGE frequency is 850/900/1800/1900 MHz, but only BAND II and PCS1900 test data included in this report. The WiFi frequency is 2.4G.

#### 2.1.2 Support function and Service

The EUT support the function and service as follows:

Service and Test mode List

Service Name	Characteristic	Corresponding Test Mode	Note
Data	Modulation: GMSK	TM1	GPRS/GSM
Data	Modulation: 8PSK	TM2	EDGE
Data	Modulation: QPSK	TM3	WCDMA
Data	Modulation: QPSK	TM4	HSDPA
Data	Modulation: QPSK	TM5	HSUPA

Note: \* The specified GPRS test conditions & settings are defined in 3GPP TS51.010 V5.4.0 and the EDGE test conditions & settings are defined in 3GPP TS51.010 V5.4.0. The WCDMA test condition & settings are defined in 3GPP TS 34.121 V8.7.0:2009.

### 2.2 Modification Information

For original equipment, following table is not application.

Modification Information

Model Number	Board/Module	Original Version	New Version	Modify Information
Not applicable				



### **3 Test Site Description**

The test site of:

***Huawei Technologies Co. Ltd.  
P.O. Box 518129  
Huawei base, bantian,  
Longgang District, Shenzhen, China***

#### **3.1 Testing Period**

The test have been performed during the period of

**Sep.16, 2011 – Sep.18, 2011**

#### **3.2 General Set up Description**

**TM1:** GSM/GPRS Mode with GMSK Modulation

**TM2:** EDGE Mode with 8PSK Modulation

**TM3:** WCDMA Mode with QPSK Modulation

**TM4:** HSDPA Mode with QPSK Modulation

**TM5:** HSUPA Mode with QPSK Modulation



## 4 Product Description

### 4.1 Technical Characteristics

#### 4.1.1 Frequency Range

Frequency Range

Uplink band:	1850 to 1910 MHz
Downlink band:	1930 to 1990 MHz

#### 4.1.2 Channel Spacing / Separation

Channel Spacing / Separation

	EDGE/GPRS/GSM	WCDMA/HSPA
Channel raster	200k Hz	200k Hz
Channel spacing:	200k Hz	5MHz

#### 4.1.3 Type of Emission

Type of Emission

	EDGE	GPRS/GSM	WCDMA/HSPA
Emission Designation:	300KG7W	300KGXW	5M00F9W

According to CFR 47 (FCC) part 2, subpart C, section 2.201 and 2.202

#### 4.1.4 Environmental Requirements

Environmental Requirements

Minimum temperature:	- 10 °C
Maximum temperature:	+ 55 °C
Relative Humidity:	5%-95%RH

#### 4.1.5 Power Source

Power Source

AC voltage nominal:	~ 120 V
AC voltage range	~ 100 V to ~ 240 V
AC current maximal:	0.2A

#### 4.1.6 Tune-up Procedure

According to CFR (FCC) part 2, subpart 2, section 2.1033(c) (9).

Please reference the document Tune-up Procedure in TCF.

#### 4.1.7 Applied DC Voltages and Currents

According to CFR (FCC) part 2, subpart 2, section 2.1033(c) (8).

The voltage and current in the final RF stage is:

Applied RF Module Voltages and Currents

Voltage:	☐ +3.7V
Current:	100mA According to CFR (FCC) part 2, subpart 2, section 2.1033(c) (8)

## 4.2 EUT Identification List



### 4.2.1 Board Information

Board Information	
Mobile WiFi	
UMG587/E587u-5	
Board and Module	
Description	Hardware Version
Main board	CP1E587M

### 4.2.2 Adapter Technical Data

Name	Manufacture	Description
Adapter	Huawei Technologies Co., Ltd.	Adapter Model: HW-050100U1W voltage nominal: ~230V Input Voltage :100-240V ~50/60Hz, 0.2A Output Voltage:  5.0V 1.0A

### 4.2.3 Battery Technical Data

Name	Manufacture	Description
Rechargeable Li-ion	Huawei Technologies Co., Ltd.	Battery Model: HB5A5P2 Rated capacity: 2200mAh Nominal Voltage:  +3.7V Charging Voltage:  +4.2V

### 4.2.4 FCC Identification

Grantee Code: QIS  
Product Code: E587u-5  
FCC Identification: QIS587U-5

### 4.2.5 IC Identification

IC Identification: 6369A-E587U5



## 5 Main Test Instruments

Main Test Equipments

Equipment Description	Manufacturer	Model	Serial Number	Calibrated until
Power supply	KEITHLEY	2303	1288003	Sep.27,2011
Universal Radio Communication Tester	R&S	CMU200	105822	Oct.24,2011
Wireless Communication Test set	Agilent	N4010A	MY49081592	Dec.14,2011
Universal Radio Communication Tester	Agilent	E5515C	MY50260239	Aug.04,2012
Signal Analyzer	R&S	FSQ31	200021	Sep.27,2011
Temperature Chamber	WEISS	WKL64	24600294	Jan.25,2012
Signal generator	Agilent	E8257D	MY49281095	Jul.09,2012
Vector Signal Generator	R&S	SMU200A	104162	Sep.07,2012
Test receiver	R&S	ESU26	36090302083	Jun.24,2012
EMI Test receiver	R&S	FSQ43	100048	Jun.23,2012
Tunable Dipole	Schwarzbeck	D69250-UHAP/D69250-VHAP	919/1009	Dec.13,2011
Tunable Dipole	Schwarzbeck	D69250-UHAP/D69250-VHAP	979/917	Dec.13,2011
Horn Antenna	R & S	HF906	359287/005	May.07, 2012
Horn Antenna	R & S	HF906	359287/006	Apr.27, 2012
Horn Antenna	R & S	HF906	100684	Jun.28,2012
Broadband Antenna	SCHAFFNER	CBL 6112B	2536	Sep.21, 2012
Broadband Antenna	SCHAFFNER	CBL 6112B	2941	Jun.20, 2012
Broadband Antenna	SCHAFFNER	VULB 9163	9163-357	Sep.28,2011
Horn Antenna	ETS-LINDGREN	3160	60008	Sep.20,2012
Horn Antenna	ETS-LINDGREN	3160	91989	Sep.28,2011



## 6 Transmitter Measurements

### 6.1 Effective Isotropic radiated power of Transmitter (EIRP)

#### 6.1.1 Test Conditions

Test Conditions

Preconditioning:	0.5 hour
Measured at:	enclosure
Ambient temperature:	25°C
Relative humidity:	55%
Test Configurations:	TM1/TM2/TM3 at frequency B, M, T

#### 6.1.2 Test Specifications and Limits

##### 6.1.2.1 Specification

CFR 47 (FCC) part 2.1046 and part 24 subpart E

##### 6.1.2.2 Supporting Standards

Supporting Standards:

ANSI/TIA-603-C:2004	Land Mobile FM or PM Communications Equipment Measurement and Performance Standards
3GPP TS51.010 V5.4.0.0:2005	Digital cellular telecommunications system Mobile Station (MS) conformance specification;
3GPP TS 34.121 V8.7.0:2009	Technical Specification Group Radio Access Network; User Equipment (UE) conformance specification; Radio transmission and reception (FDD);

##### 6.1.2.3 Limits

Compliance with part 24.232, mobile/portable stations are limited to 2 watts EIRP peak power.  
 $W(\text{dBm}) = 10 \cdot \log(W_{\text{In mW}})$ .

Limits

Maximum Output Power (Watts)	< 2 Watts
Maximum Output Power (dBm)	< 33 dBm

#### 6.1.3 Test Method and Setup

- (a) For transmitters other than single sideband, independent sideband and controlled carrier radiotelephone, EIRP shall be measured when the transmitter is adjusted in accordance with the tune-up procedure to give the values of current and voltage on the circuit elements specified in 2.1033(c)(8). Connect the EUT to the wireless communication tester CMU200 via the air interface. The band is set as PCS.
- (b) Test the Radiated maximum output power by the CMU200 received from test antenna.

- (c) Use substitution method to verify the maximum output power. The EUT is substituted by a horn antenna. The horn is connected to a signal generator. And then adjust the output level of the signal generator to get the same received power recorded in step (b) on CMU200, and record the power level of Signal Generator. Of course, the cable loss at the test frequency should be compensated.

**Test setup**

**Step 1: Pre-test**

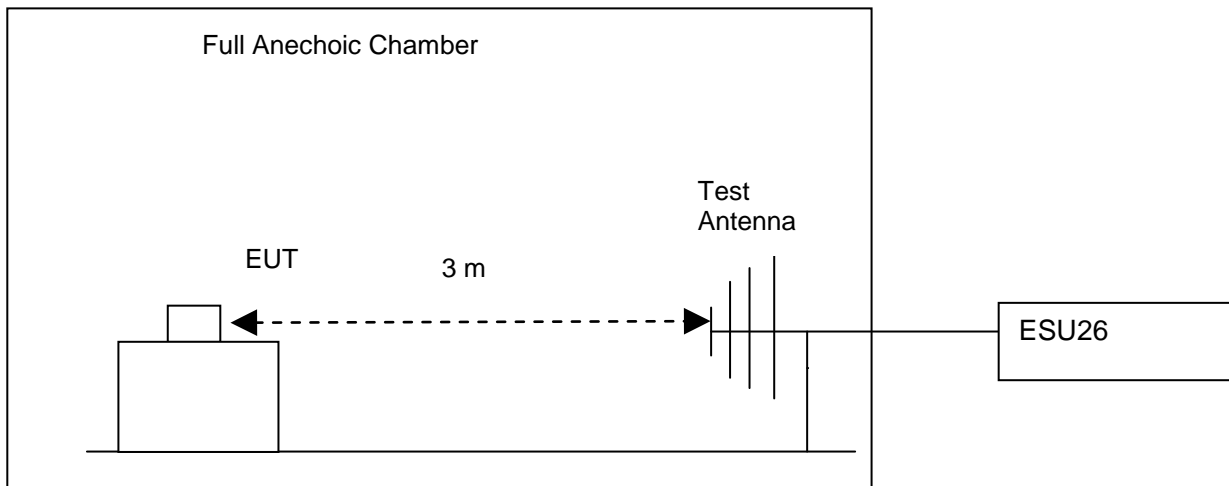

**Step 2: Substitution method to verify the maximum EIRP**

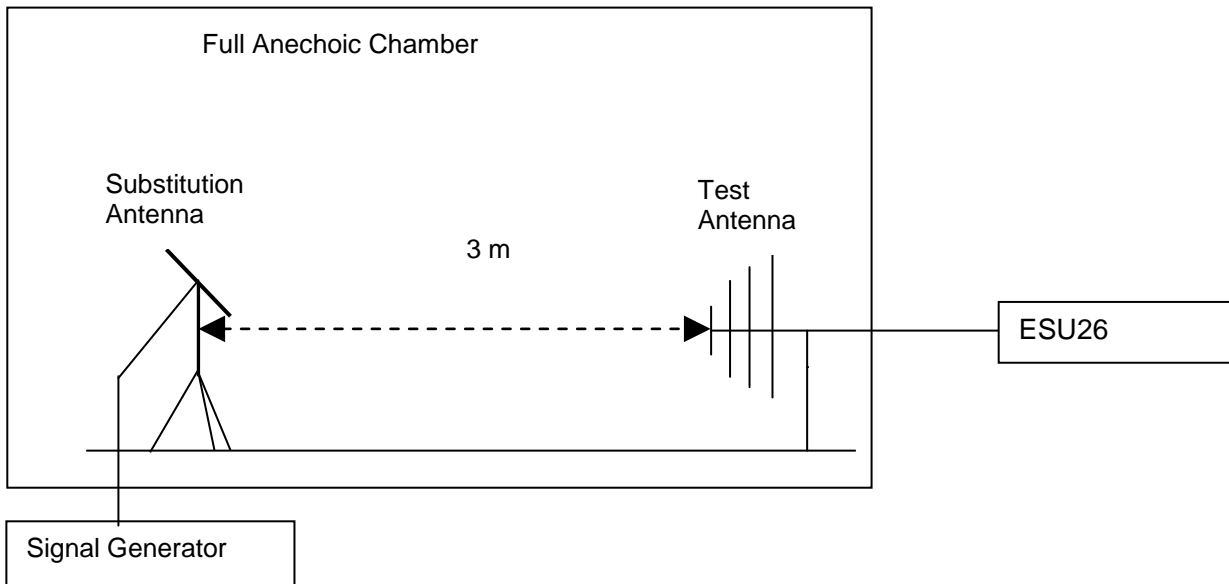

Figure 1. Test Set-up

NOTE: Effective Isotropic radiated power (EIRP) refers to the radiation power output of the EUT, assuming all emissions are radiated from half-wave horn antennas.

There is a constant difference of 2.15 dB between EIRP and ERP.

$EIRP (dBm) = ERP (dBm) + 2.15$  (ITU-R Recommendation SM.329-10).

EIRP was measured using 1 host.

**BenQ Joy book S72**

## 6.1.4 Measurement Results

### 6.1.4.1 Pre-test Results

Measurement Results

RF Output Power (EIRP)						
TEST CONDITIONS	Channel 512(B) 1850.2MHz		Channel 661(M) 1880.0MHz		Channel 810(T) 1909.8MHz	
	dBm		dBm		dBm	
T <sub>nom</sub> (25 °C)/ V <sub>nom</sub> (3.7V)	Measured	Limit	Measured	Limit	Measured	Limit
TM1	30.37	33	30.41	33	30.42	33
TM2	26.17	33	26.05	33	26.01	33

RF Output Power (EIRP)						
TEST CONDITIONS	Channel 9262(B) 1852.4MHz		Channel 9400(M) 1880.0MHz		Channel 9538(T) 1907.6MHz	
	dBm		dBm		dBm	
T <sub>nom</sub> (25 °C)/ V <sub>nom</sub> (3.7V)	Measured	Limit	Measured	Limit	Measured	Limit
TM3	22.76	33	22.74	33	22.81	33

### 6.1.4.2 Substitution Results

Substitution Results

Test Mode	Freq. [MHz]	Meas. Level [dBm]	Substitution Antenna Type	SGP [dBm]	Substitution Gain [dBi]	Cable Loss [dB]	Substitution Level (EIRP) [dBm]	FCC limit [dBm]	Result
TM1	1850.2	30.37	Horn Ant.	26.37	4.5	1	29.87	33	Pass
TM1	1880.0	30.41	Horn Ant.	26.26	4.5	1	29.76	33	Pass
TM1	1909.8	30.42	Horn Ant.	25.99	4.8	1	29.79	33	Pass
TM2	1850.2	26.17	Horn Ant.	22.63	4.5	1	26.13	33	Pass
TM2	1880.0	26.05	Horn Ant.	22.7	4.5	1	26.20	33	Pass
TM2	1909.8	26.01	Horn Ant.	22.38	4.8	1	26.18	33	Pass
TM3	1852.4	22.76	Horn Ant.	19.26	4.5	1	22.76	33	Pass
TM3	1880.0	22.74	Horn Ant.	19.2	4.5	1	22.70	33	Pass
TM3	1907.6	22.81	Horn Ant.	19.01	4.8	1	22.81	33	Pass



Note: a, For get the EIRP (Efficient Isotropic Radiated Power) in substitution method, the following formula should take to calculate it,

$$\text{EIRP [dBm]} = \text{SGP [dBm]} - \text{Cable Loss [dB]} + \text{Gain [dBi]}$$

NOTE: SGP- Signal Generator Level

b, Measurement the EIRP with RMS detector.

c, RBW=10kHz, VBW=300kHz, and integrated by the instrument to 250kHz for TM1 and TM2 and 5M for TM3.

### 6.1.5 Conclusion

The equipment **PASSED** the requirement of this clause.



## 6.2 Conducted Power of Transmitter

### 6.2.1 Test Conditions

Test Conditions

Preconditioning:	0.5 hour
Measured at:	Antenna connector
Ambient temperature:	25 °C
Relative humidity:	55 %
Test Configurations:	TM1/TM2/TM3/TM4/TM5 at frequency B, M, T

### 6.2.2 Test Specifications and Limits

#### 6.2.2.1 Specification

CFR 47 (FCC) part 2.1047 and part 24 subpart E

#### 6.2.2.2 Supporting Standards

Supporting Standards:

ANSI/TIA-603-C: 2004	Land Mobile FM or PM Communications Equipment Measurement and Performance Standards
3GPP TS51.010 V5.4.0.0:2005	Digital cellular telecommunications system Mobile Station (MS) conformance specification;
3GPP TS 34.121 V8.7.0:2009	Technical Specification Group Radio Access Network; User Equipment (UE) conformance specification; Radio transmission and reception (FDD);

#### 6.2.2.3 Limits

Compliance with part 24.232, in no any case may the peak power of a mobile station transmitter exceed 2 W. The calculated longitude EIRP by following formula:

$$EIRP(dBm) = 10 * \log(EIRP_{in\ mW}).$$

And for conducted power, we can use Antenna Gain to calculate the limit. So the conducted power:

$$P_{cod.}(dBm) = EIRP(dBm) - Gain(dBi).$$

and  $Gain(dBi) = Gain(dBd) + 2.15dB$

Limits

Maximum Output Power (Watts)	< 2 Watts (33 dBm)
Antenna Gain(dBi):	0.5
Antenna Gain(dBd):	-1.65
Maximum Conducted Output Power (dBm)	< 32.5

For HSDPA test mode, there are 4 sub-tests for different configuration.

HSDPA conducted max power pre-scan

Sub-test	$\beta_c$	$\beta_d$	$\beta_d$ (SF)	$\beta_c/\beta_d$	HS (Note1, Note 2)	CM (dB) (Note 3)	MPR (dB) (Note 3)
1	2/15	15/15	64	2/15	4/15	0	0
2	12/15	15/15	64	12/15	24/15	1	0
3	15/15	8/15	64	15/8	30/15	1.5	0.5
4	15/15	4/15	64	15/4	30/15	1.5	0.5

For HSUPA test mode, there are 5 sub-tests for different configuration.

HSUPA conducted max power pre-scan

Sub-test	$\beta_c$	$\beta_d$	$\beta_d$ (SF)	$\beta_c/\beta_d$	$\beta_{HS}$ (Note 1)	$\beta_{ec}$	$\beta_{ed}$ (Note 5) (Note 6)	$\beta_{ed}$ (SF)	$\beta_{ed}$ (Codes)	CM (dB) (Note 2)	MPR (dB) (Note 2)	AG Index (Note 6)	E-TFCI
1	11/15 (Note 3)	15/15 (Note 3)	64	11/15 (Note 3)	22/15	209/22 5	1309/22 5	4	1	1.0	0.0	20	75
2	6/15	15/15	64	6/15	12/15	12/15	94/75	4	1	3.0	2.0	12	67
3	15/15	9/15	64	15/9	30/15	30/15	$\beta_{ed1}$ : 47/15 $\beta_{ed2}$ : 47/15	4 4	2	2.0	1.0	15	92
4	2/15	15/15	64	2/15	4/15	2/15	56/75	4	1	3.0	2.0	17	71
5	15/15 (Note 4)	15/15 (Note 4)	64	15/15 (Note 4)	30/15	24/15	134/15	4	1	1.0	0.0	21	81

Note 1:  $\Delta_{ACK}$ ,  $\Delta_{NACK}$  and  $\Delta_{CQI} = 30/15$  with  $\beta_{hs} = 30/15 * \beta_c$ .

Note 2: CM = 1 for  $\beta_c/\beta_d = 12/15$ ,  $\square_{hs}/\square_c = 24/15$ . For all other combinations of DPDCH, DPCCH, HS-DPCCH, E-DPDCH and E-DPCCH the MPR is based on the relative CM difference.

Note 3: For subtest 1 the  $\square_c/\square_d$  ratio of 11/15 for the TFC during the measurement period (TF1, TF0) is achieved by setting the signalled gain factors for the reference TFC (TF1, TF1) to  $\square_c = 10/15$  and  $\square_d = 15/15$ .

Note 4: For subtest 5 the  $\square_c/\square_d$  ratio of 15/15 for the TFC during the measurement period (TF1, TF0) is achieved by setting the signalled gain factors for the reference TFC (TF1, TF1) to  $\square_c = 14/15$  and  $\square_d = 15/15$ .

Note 5: In case of testing by UE using E-DPDCH Physical Layer category 1, Sub-test 3 is omitted according to TS25.306 Table 5.1g.

Note 6:  $\beta_{ed}$  can not be set directly, it is set by Absolute Grant Value.

### 6.2.3 Test Method and Setup

(a) For transmitters other than single sideband, independent sideband and controlled carrier radiotelephone, Conducted maximum power shall be measured when the transmitter is adjusted in accordance with the tune-up procedure to give the values of current and voltage on the circuit elements specified in 2.1033(c)(8). Connect the EUT to the wireless communication tester CMU200 via the antenna connector. The band class is set as PCS.

(b) Test the Conducted maximum output power by the CMU200.

### Test setup

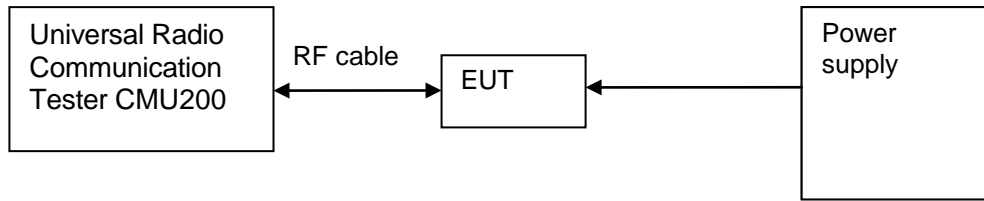

Figure 2. Test Set-up

### 6.2.4 Measurement Results

#### Measurement Results

TEST CONDITIONS		RF Output Power (Conducted)					
		Channel 512(B)		Channel 661(M)		Channel 810(T)	
		1850.2MHz		1880.0MHz		1909.8MHz	
		dBm		dBm		dBm	
T <sub>nom</sub> (25 °C)/ V <sub>nom</sub> (3.7V)		Measure d	Limit	Measured	Limit	Measure d	Limit
TM1		29.87	32.5	29.91	32.5	29.92	32.5
TM2		25.67	32.5	25.55	32.5	25.51	32.5
TEST CONDITIONS		Channel 9262(B)		Channel 9400(M)		Channel 9538(T)	
		1852.4MHz		1880.0MHz		1907.6MHz	
		dBm		dBm		dBm	
T <sub>nom</sub> (25 °C)/ V <sub>nom</sub> (3.7V)		Measure d	Limit	Measured	Limit	Measure d	Limit
TM3		22.26	32.5	22.24	32.5	22.31	32.5
TM4	Case1	20.93	32.5	20.8	32.5	20.96	32.5
	Case2	20.21	32.5	20.56	32.5	20.31	32.5
	Case3	19.62	32.5	20.02	32.5	19.58	32.5
	Case4	19.49	32.5	20.04	32.5	19.41	32.5
TM5	Case1	20.64	32.5	20.48	32.5	20.32	32.5
	Case2	19.74	32.5	19.63	32.5	19.77	32.5
	Case3	20.46	32.5	20.23	32.5	20.56	32.5
	Case4	20.18	32.5	19.98	32.5	20.23	32.5
	Case5	20.74	32.5	20.54	32.5	20.65	32.5

Note: Measurement the Conducted output power with RMS detector.



---

## 6.2.5 Conclusion

The equipment **PASSED** the requirement of this clause.

## 6.3 Modulation Characteristics

### 6.3.1 Test Conditions

Test Conditions

Preconditioning:	0.5 hour
Measured at:	Antenna connector
Ambient temperature:	25 °C
Relative humidity:	55 %
Test Configurations:	TM1/TM2/TM3 at frequency M

### 6.3.2 Test Specifications and Limits

#### 6.3.2.1 Specification

CFR 47 (FCC) part 2.1047 and part 24 subpart E

#### 6.3.2.2 Supporting Standards

Supporting Standards:

ANSI/TIA-603-C: 2004	Land Mobile FM or PM Communications Equipment Measurement and Performance Standards
3GPP TS51.010 V5.4.0.0:2005	Digital cellular telecommunications system Mobile Station (MS) conformance specification;
3GPP TS 34.121 V8.7.0:2009	Technical Specification Group Radio Access Network; User Equipment (UE) conformance specification; Radio transmission and reception (FDD);

#### 6.3.2.3 Limits

No specific modulation characteristics requirement limits in part 2.1047 and part 24 subpart E.

Limits

Limits	Not applicable
--------	----------------

### 6.3.3 Test Method and Setup

Connect the EUT to Universal Radio Communication Tester CMU200 via the antenna connector. The frequency band is set as PCS; the EUT's output is matched with 50 Ω load, test method was according to 3GPP TS 51.010 and 3GPP TS 34.121. The waveform quality and constellation of the EUT was tested.

## Test setup

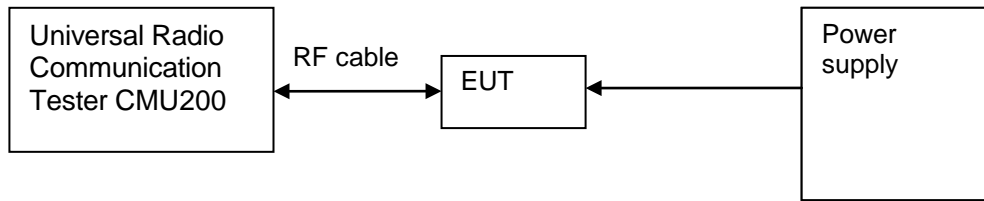

Figure 3. Test Set-up

### 6.3.4 Measurement Results

#### Measurement Results

TEST CONDITIONS		Modulation Characteristic	
		Measured	
		TM1	TM2
$T_{nom}$ (25 °C)	$V_{nom}$ (3.7V)	Refer to Appendix A	Refer to Appendix A
TEST CONDITIONS		Channel 9400(M) 1880.0MHz	
		Measured	
		TM3	
$T_{nom}$ (25 °C)	$V_{nom}$ (3.7V)	Refer to Appendix A	

### 6.3.5 Conclusion

The equipment **PASSED** the requirement of this clause.

For the measurement results refer to appendix A.

## 6.4 Occupied Bandwidth

### 6.4.1 Test Conditions

Test Conditions

Preconditioning:	0.5 hour
Measured at:	Antenna connector
Ambient temperature:	25 °C
Relative humidity:	55 %
Test Configurations:	TM1/TM2/TM3 at frequency B, M, T

### 6.4.2 Test Specifications and Limits

#### 6.4.2.1 Specification

CFR 47 (FCC) part 2.1049 and part 24 subpart E

#### 6.4.2.2 Supporting Standards

Supporting Standards:

ANSI/TIA-603-C: 2004	Land Mobile FM or PM Communications Equipment Measurement and Performance Standards
3GPP TS51.010 V5.4.0.0:2005	Digital cellular telecommunications system Mobile Station (MS) conformance specification;
3GPP TS 34.121 V8.7.0:2009	Technical Specification Group Radio Access Network; User Equipment (UE) conformance specification; Radio transmission and reception (FDD);

#### 6.4.2.3 Limits

No specific occupied bandwidth requirement in part 24 subpart E, but the occupied bandwidth was defined in part 2.1049: the frequency bandwidth such that, below its lower and above its upper frequency limits, the mean powers radiated are each equal to 0.5 percent of the total mean power radiated by a given emission shall be measured.

Limits

Upper /lower frequency limits	0.5% of the mean power
-------------------------------	------------------------

### 6.4.3 Test Method and Setup

The EUT was connected to the wireless signal analyzer R&S FSQ31 via the one RF connector. The band class is set as PCS; The EUT was controlled to transmit maximum power. Measure and record the occupied bandwidth of the EUT by the R&S FSQ31.

The OBW, that is the frequency bandwidth such that, below its lower and above its upper frequency limits, the mean powers radiated are each equal to 0.5 percent of the total mean power radiated by a given emission shall be measured under the following conditions as applicable:

Refer to 47CFR part2.1049 section (g)&(h).

(g) Transmitter in which the modulating base band comprises not more than three independent channels - when modulated by the full complement of signals for which the transmitter is rated. The level of modulation for each channel should be set to that prescribed in rule parts applicable to the services for which the transmitter is intended. If specific modulation levels are not set forth in the rules, the tests should provide the manufacturer's maximum rated condition.

(h) Transmitters employing digital modulation techniques - when modulated by an input signal such that its amplitude and symbol rate represent the maximum rated conditions under which the equipment will be operated. The signal shall be applied through any filter networks, pseudorandom generators or other devices required in normal service. Additionally, the occupied bandwidth shall be shown for operation with any devices used for modifying the spectrum when such devices are optional at discretion of the user.

For TM1/TM2 following RBW and VBW are employed:

Measurement bandwidth (RBW): 3 kHz (Resolution bandwidth)

Video bandwidth (VBW): 10 kHz

For TM3 following RBW and VBW are employed:

Measurement bandwidth (RBW): 50 kHz (Resolution bandwidth)

Video bandwidth (VBW): 500 kHz

### Test Set-up

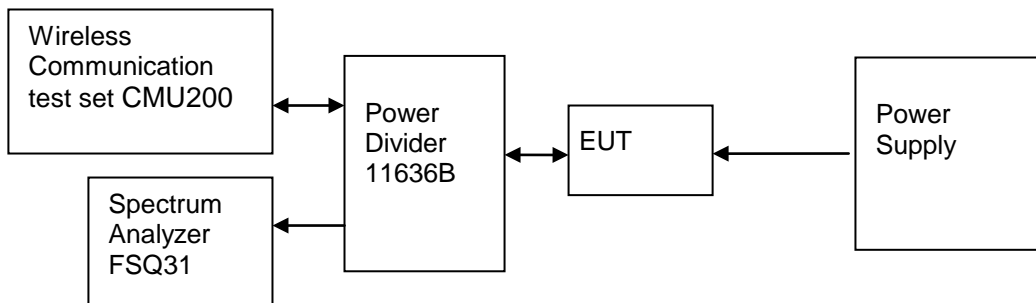

Figure 4. Test Set-up

### 6.4.4 Measurement Results

Measurement Results

TEST CONDITIONS		Occupied Bandwidth					
		Channel 512(B)		Channel 661(M)		Channel 810(T)	
Center Frequency		1850.2MHz		1880.0MHz		1909.8MHz	
		Measured		Measured		Measured	
		(kHz)		(kHz)		(kHz)	
		TM1	TM2	TM1	TM2	TM1	TM2
T <sub>nom</sub> (25 °C)/ V <sub>nom</sub> (3.7V)	99%	245.19	248.40	245.19	248.40	246.79	246.79





		Channel 9262(B)	Channel 9400(M)	Channel 9538(T)
Center Frequency		1852.4MHz	1880.0MHz	1907.6MHz
		Measured	Measured	Measured
		(MHz)	(MHz)	(MHz)
		TM3	TM3	TM3
T <sub>nom</sub> (25 °C)/ V <sub>nom</sub> (3.7V)	99%	4.07	4.05	4.07

### 6.4.5 Conclusion

The equipment **PASSED** the requirement of this clause.  
 For the measurement results refer to appendix B.

## 6.5 Band Edges Compliance

### 6.5.1 Test Conditions

Test Conditions

Preconditioning:	0.5 hour
Measured at:	Antenna connector
Ambient temperature:	25°C
Relative humidity:	55 %
Test Configurations:	TM1/TM2/TM3 at frequency B, T

### 6.5.2 Test Specifications and Limits

#### 6.5.2.1 Specification

CFR 47 (FCC) part 2.1051 and Part24 Subpart E

#### 6.5.2.2 Supporting Standards

Supporting Standards:

ANSI/TIA-603-C: 2004	Land Mobile FM or PM Communications Equipment Measurement and Performance Standards
3GPP TS51.010 V5.4.0.0:2005	Digital cellular telecommunications system Mobile Station (MS) conformance specification;
3GPP TS 34.121 V8.7.0:2009	Technical Specification Group Radio Access Network; User Equipment (UE) conformance specification; Radio transmission and reception (FDD);

#### 6.5.2.3 Limits

Compliance with part 24.238, all spurious emission must be attenuated below the transmitter power by at least  $43 + 10 \log_{10} P(W)$ . (Whereas P is the rated power of the EUT).

Limits

	TM1	TM2	TM3
Rated Power:	30 dBm	26 dBm	24 dBm
Required attenuation:	$43 + 10 \log(1) = 43$ , 30 dBm - 43 dB	$43 + 10 \log(0.4) = 39$ , 26 dBm - 39 dB	$43 + 10 \log(0.25) = 37$ , 24 dBm - 37 dB
Absolute level	- 13 dBm	- 13 dBm	- 13 dBm

### 6.5.3 Test Method and Setup

The EUT was connected to the wireless signal analyzer R&S FSQ31 via the one RF connector, the band class is set as PCS. The EUT was controlled to transmit maximum power. Measure and record band edges compliance of the EUT by the R&S FSQ31.

For TM1/TM2 following RBW and VBW are employed:  
 Measurement bandwidth (RBW): 3 kHz (Resolution bandwidth)  
 Video bandwidth (VBW): 10 kHz  
 For TM3 following RBW and VBW are employed:  
 Measurement bandwidth (RBW): 50 kHz (Resolution bandwidth)  
 Video bandwidth (VBW): 200 kHz

### Test Set-up

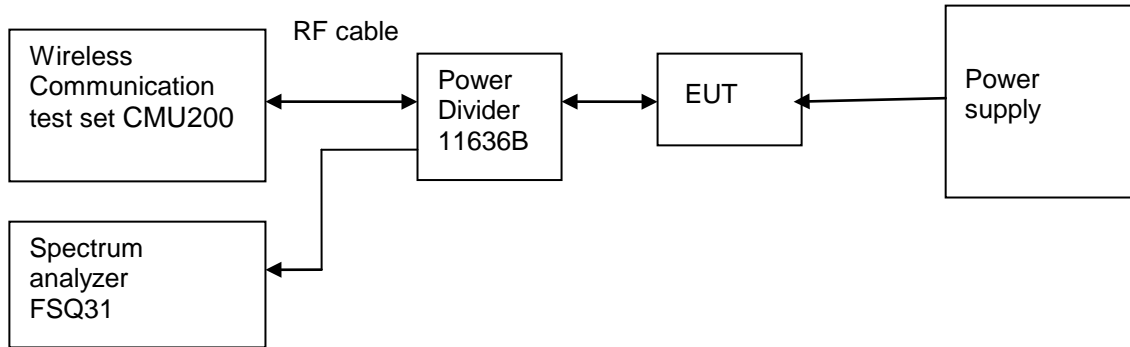

Figure 5. Test Set-up

### 6.5.4 Measurement Results

Measurement Results outside Band Edges-- Single Carrier

Band	Frequency of Band edges [MHz]	Channel Number	Test Mode	Spurious Level measured [dBm]	FCC limit	Result
$T_{nom} (25\text{ }^{\circ}\text{C}), V_{nom} (3.7\text{V})$						
PCS	1850.2	512	TM1	<-13(See appendix C)	- 13 dBm	Pass
	1909.8	810	TM1	<-13(See appendix C)	- 13 dBm	Pass
	1850.2	512	TM2	<-13(See appendix C)	- 13 dBm	Pass
	1909.8	810	TM2	<-13(See appendix C)	- 13 dBm	Pass
	1852.4	9262	TM3	<-13(See appendix C)	- 13 dBm	Pass
	1907.6	9538	TM3	<-13(See appendix C)	- 13 dBm	Pass

### 6.5.5 Conclusion

The equipment **PASSED** the requirement of this clause.  
 For the measurement results refer to appendix C.

## 6.6 Spurious Emission at Antenna Terminal

### 6.6.1 Test Conditions

Test Conditions

Preconditioning:	0.5 hour
Measured at:	Antenna connector
Ambient temperature:	25°C
Relative humidity:	55 %
Test Configurations:	TM1/TM2/TM3 at frequency B, M ,T

### 6.6.2 Test Specifications and Limits

#### 6.6.2.1 Specification

CFR 47 (FCC) part 2.1051 and Part24 Subpart E

#### 6.6.2.2 Supporting Standards

Supporting Standards:

ANSI/TIA-603-C: 2004	Land Mobile FM or PM Communications Equipment Measurement and Performance Standards
3GPP TS51.010 V5.4.0.0:2005	Digital cellular telecommunications system Mobile Station (MS) conformance specification;
3GPP TS 34.121 V8.7.0:2009	Technical Specification Group Radio Access Network; User Equipment (UE) conformance specification; Radio transmission and reception (FDD);

#### 6.6.2.3 Limits

Compliance with part 24.238, all spurious emission must be attenuated below the transmitter power by at least  $43 + 10 \log_{10} P$ . (Whereas P is the rated power of the EUT).

Limits

	TM1	TM2	TM3
Rated Power:	30 dBm	26 dBm	24 dBm
Required attenuation:	$43 + 10 \log(1) = 43$ , 30 dBm - 43 dB	$43 + 10 \log(0.4) = 39$ , 26 dBm - 39 dB	$43 + 10 \log(0.25) = 37$ , 24 dBm - 37 dB
Absolute level	- 13 dBm	- 13 dBm	- 13 dBm

### 6.6.3 Test Method and Setup

The EUT was connected to the wireless signal analyzer R&S FSQ31 via the one RF connector, the band class is set as PCS. The EUT was controlled to transmit maximum power. Measure and record the Conducted Spurious Emission of the EUT by the R&S FSQ31.

According to part 24.238, the defined measurement bandwidth as following:

24.238 (b) Measurement procedure: Compliance with these provisions is based on the use of measurement instrumentation employing a resolution bandwidth of 1 MHz or greater.

Measurement bandwidth (RBW) for 9 kHz up to 150 kHz: 1 kHz;  
 Measurement bandwidth (RBW) for 150 kHz up to 30MHz: 10 kHz;  
 Measurement bandwidth (RBW) for 30 MHz up to 20GHz: 1MHz;

### Test Set-up

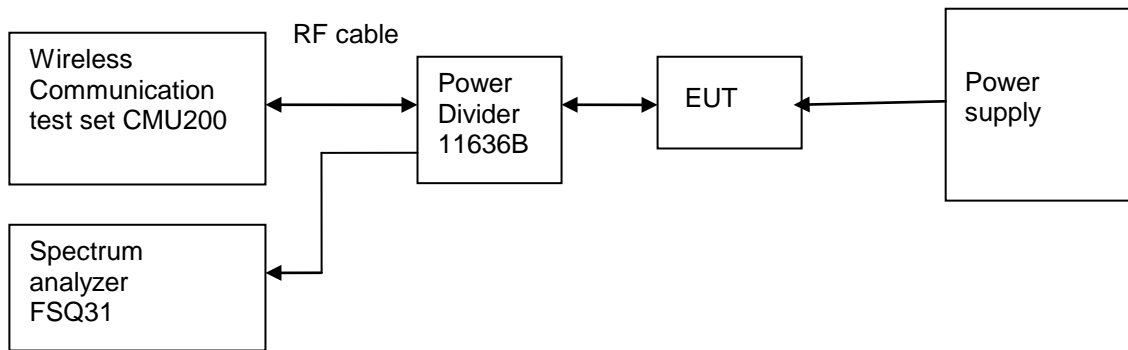

Figure 6. Test Set-up

### 6.6.4 Measurement Results

Measurement Results

Channel Number	Test Mode	Test Range (Frequency)	Output Power [dBm]	Spurious Level measured [dBm]	FCC limit	Result
Channel 512(B)	TM1	9 kHz~20GHz	30	<- 13 dBm (See appendix D)	- 13 dBm	Pass
	TM2	9 kHz~20GHz	26	<- 13 dBm (See appendix D)	- 13 dBm	Pass
Channel 9262(B)	TM3	9 kHz~20GHz	24	<- 13 dBm (See appendix D)	- 13 dBm	Pass
Channel 661(M)	TM1	9 kHz~20GHz	30	<- 13 dBm (See appendix D)	- 13 dBm	Pass
	TM2	9 kHz~20GHz	26	<- 13 dBm (See appendix D)	- 13 dBm	Pass

Channel 9400(M)	TM3	9 kHz~20GHz	24	<- 13 dBm (See appendix D)	- 13 dBm	Pass
Channel 810(T)	TM1	9 kHz~20GHz	30	<- 13 dBm (See appendix D)	- 13 dBm	Pass
	TM2	9 kHz~20GHz	26	<- 13 dBm (See appendix D)	- 13 dBm	Pass
Channel 9538(T)	TM3	9 kHz~20GHz	24	<- 13 dBm (See appendix D)	- 13 dBm	Pass

### 6.6.5 Conclusion

The equipment **PASSED** the requirement of this clause.  
For the measurement results refer to appendix D.

## 6.7 Radiated Spurious Emissions

### 6.7.1 Test Conditions

Test Conditions

Preconditioning:	0.5 hour
Measured at:	enclosure
Ambient temperature:	25°C
Relative humidity:	55%
Test Configurations:	TM1/TM2/TM3/TM4/TM5 at frequency M

### 6.7.2 Test Specifications and Limits

#### 6.7.2.1 Specification

CFR 47 (FCC) part 2.1053 and part 24.238

#### 6.7.2.2 Supporting Standards

Supporting Standards:

ANSI/TIA-603-C: 2004	Land Mobile FM or PM Communications Equipment Measurement and Performance Standards
3GPP TS51.010 V5.4.0.0:2005	Digital cellular telecommunications system Mobile Station (MS) conformance specification;
3GPP TS 34.121 V8.7.0:2009	Technical Specification Group Radio Access Network; User Equipment (UE) conformance specification; Radio transmission and reception (FDD);

#### 6.7.2.3 Limits

Compliance with part 24.238, all spurious emission must be attenuated below the transmitter power by at least  $43 + 10 \log_{10} P$ . (Whereas P is the rated power of the EUT).

Limits

Absolute level	- 13 dBm
----------------	----------

### 6.7.3 Test Method and Setup

A test site fulfilling the requirements of ITU-R Recommendation SM329-11 was used. The EUT was placed on a non-conducting support in the anechoic chamber and was operated from a power source via an RF filter to avoid radiation from the power leads.

According to part 24.238, the defined measurement bandwidth as following:

24.238(b) Measurement procedure: Compliance with these rules is based on the use of measurement instrumentation employing a resolution bandwidth of 1 MHz or greater.

Measurement bandwidth (RBW) for 9 kHz up to 150 kHz: 1 kHz;  
Measurement bandwidth (RBW) for 150 kHz up to 30 MHz: 10 kHz;  
Measurement bandwidth (RBW) for 30MHz up to 26.5GHz: 1MHz;

## Test Set-up

### Step 1:

For transmitters other than single sideband, independent sideband and controlled carrier radiotelephone, EIRP shall be measured when the transmitter is adjusted in accordance with the tune-up procedure to give the values of current and voltage on the circuit elements specified in 2.1033(c)(8). Connect the EUT to the BTS simulator via the air interface.

Test the Radiated maximum output power by the Test Receiver from test antenna.

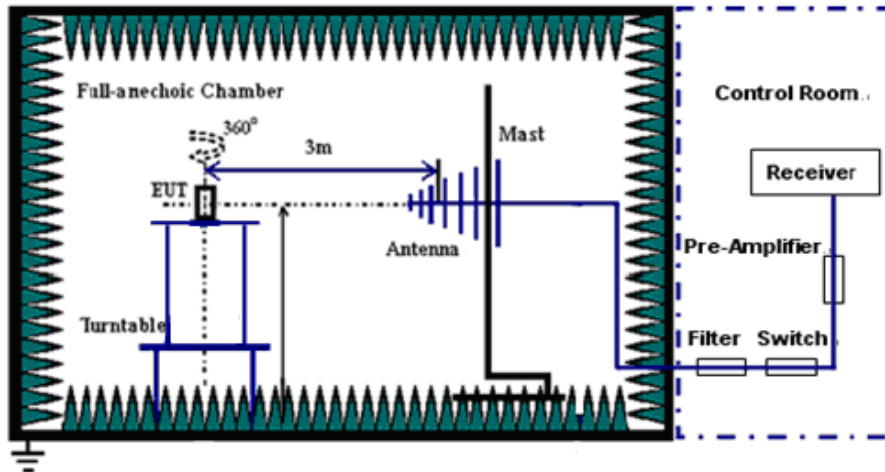

### Step 2:

Use substitution method to verify the maximum output power. The EUT is substituted by a dipole antenna. The dipole is connected to a signal generator. And then adjust the output level of the signal generator to get the same received power recorded in step1 on Test Receiver, and record the power level of Signal Generator. Of course, the cable loss at the test frequency should be compensated.

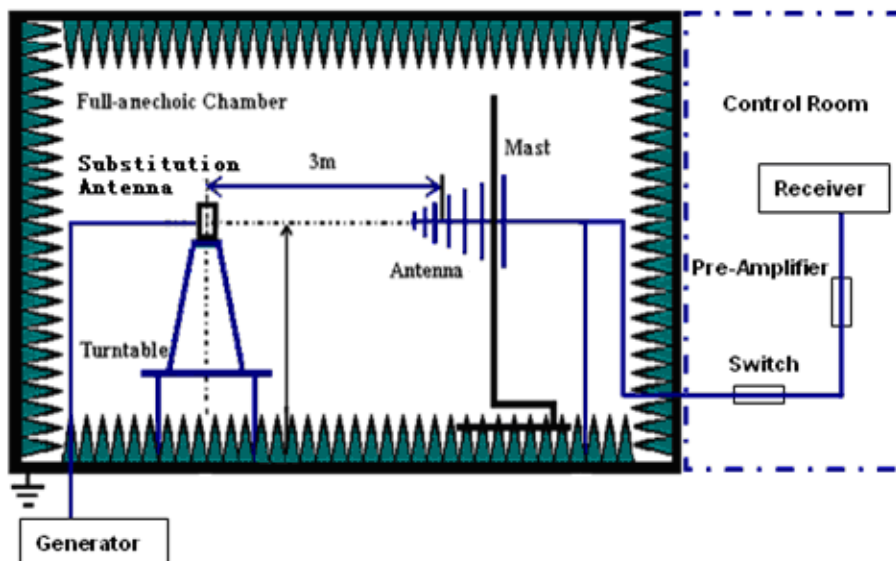

Test should be performed in normal voltage condition.

No peak found in pre- test. All frequency points' margin is bigger than 20dB, so the substitution method





isn't used.

Calculation Sample:

Substitution Results

Freq. [MHz]	Measurement Value [dBm]	Substitution Antenna Type	Gain [dBd]	Cable Loss [dB]	Signal Generator Level [dBm]	Substitution Level [dBm]	FCC limit [dBm]	Result

Note: For get the E.R.P. (Efficient Radiated Power) in substitution method, the following formula should take to calculate it,

$$E.R.P. [dBm] = SGP [dBm] - Cable Loss [dB] + Gain [dBd]$$

NOTE: SGP- Signal Generator Level

### 6.7.4 Conclusion

The equipment **PASSED** the requirement of this clause.  
 For the measurement results refer to appendix\_E

## 6.8 Receiver Spurious Emissions

### 6.8.1 Test Conditions

Table 2 Test Conditions

Preconditioning:	0.5 hour
Measured at:	enclosure
Ambient temperature:	25 °C
Relative humidity:	55 %
Test Configurations:	TM1/TM2/TM3/TM4/TM5 at frequency M

### 6.8.2 Test Specifications and Limits

#### 6.8.2.1 Specification

IC RSS-Gen 4.10 and RSS-133 6.6

#### 6.8.2.2 Supporting Standards

Table 3 Supporting Standards:

ANSI/TIA-603-C: 2004	Land Mobile FM or PM Communications Equipment Measurement and Performance Standards
3GPP TS51.010 V5.4.0.0:2005	Digital cellular telecommunications system Mobile Station (MS) conformance specification;
3GPP TS 34.121 V8.7.0:2009	Technical Specification Group Radio Access Network; User Equipment (UE) conformance specification; Radio transmission and reception (FDD);

#### 6.8.2.3 Limits

Compliance with RSS-133 6.6, Receiver Spurious Emission must meet the requirement of following table.

Table 4 Test Limits

Frequency of Emission (MHz)	Radiated Limit		
	Unit( $\mu\text{V}/\text{m}$ )	Unit( $\text{dB}\mu\text{V}/\text{m}$ )	Detector
30-88	100	40	QP
88-216	150	43.5	QP
216-960	200	46	QP
960-1000	500	54	QP
Above 1000	500	54	AV
Above 1000	500	74	PK

### 6.8.3 Test Method and Setup

The EUT was connected to the Spectrum Analyzer or equivalent via one RF RX diversity connector, and other RF connectors were connected to match loads. The EUT was controlled to transmit maximum power and to be operated in the normal receive mode by Console Computer. Measure and record the Receiver Out-band Spurious Emissions of the EUT by the Spectrum Analyzer or equivalent.

According to IC RSS-Gen clause 4.10, the search for spurious emissions shall be from the lowest frequency internally generated or used in the receiver (e.g. local oscillator, intermediate or carrier frequency), or 30 MHz, whichever is the higher, to at least 3 times the highest tuneable or local oscillator frequency, whichever is the higher, without exceeding 40 GHz.

A preliminary scan and a final scan of the emissions were made from 30 MHz to 18 GHz by using test script of software; the emissions were measured using Quasi-Peak Detector (30MHz~1GHz) and AV detector (above 1GHz). The maximal emission value was acquired by adjusting the antenna height, polarisation and turntable azimuth in accordance with the software setup. Normally, the height range of antenna was 1m to 4m, the azimuth range of turntable was 0° to 360°, The receive antenna has two polarizations V and H.

EUT was configured in idle mode and the test performed at worst emission state.

Measurement bandwidth: 30 MHz – 1000 MHz: 120 kHz

Measurement bandwidth: 1GHz – 18GHz: 1MHz

Test set up figure:

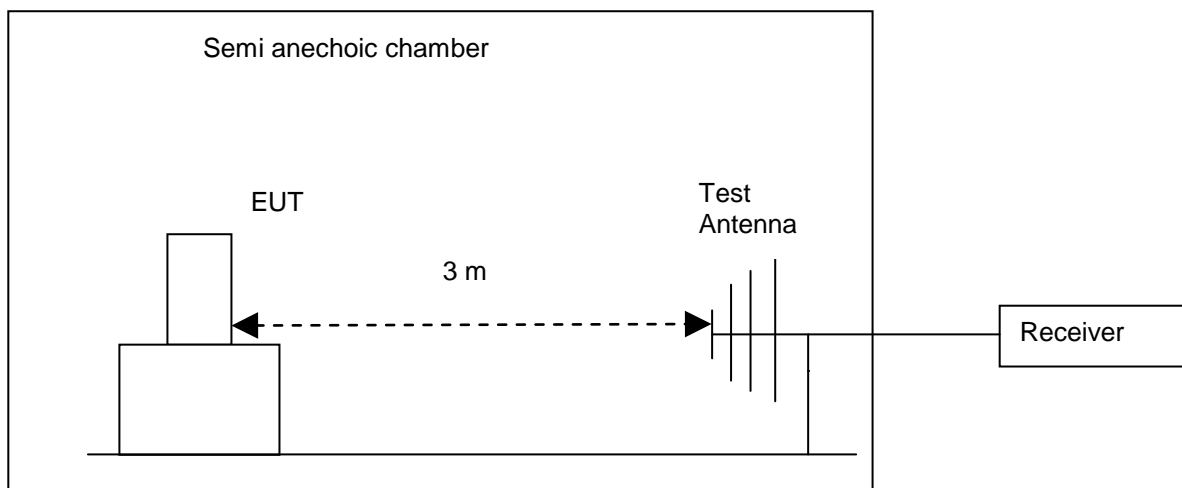

Figure 1. Test set-up

The EUT has met the requirements for Radiated Emission of enclosure port.

#### 6.8.4 Conclusion

The equipment **PASSED** the requirement of this clause.

For the measurement results refer to appendix F.

## 6.9 Frequency Stability

### 6.9.1 Test Conditions

Test Conditions

Preconditioning:	0.5 hour
Measured at:	Antenna connector
Ambient temperature:	See below
Relative humidity:	55 %
Test Configurations:	TM1/TM2/TM3 at frequency M

### 6.9.2 Test Specifications and Limits

#### 6.9.2.1 Specification

CFR 47 (FCC) part 2.1055 and Part24 Subpart E

#### 6.9.2.2 Supporting Standards

Supporting Standards:

ANSI/TIA-603-C: 2004	Land Mobile FM or PM Communications Equipment Measurement and Performance Standards
3GPP TS51.010 V5.4.0.0:2005	Digital cellular telecommunications system Mobile Station (MS) conformance specification;
3GPP TS 34.121 V8.7.0:2009	Technical Specification Group Radio Access Network; User Equipment (UE) conformance specification; Radio transmission and reception (FDD);

#### 6.9.2.3 Limits

No specific frequency stability requirement in part 2.1055 and part 24.235.

### 6.9.3 Test Method and Setup

The frequency stability shall be measured with variation of ambient temperature as follows:

- (1) From -30 ° to +50 ° centigrade for all equipment except that specified in subparagraphs
- (2) and (3) of paragraph 2.1055

(a) Frequency measurements shall be made at the extremes of the specified temperature range and at intervals of not more than 10° centigrade through the range. A period of time sufficient to stabilize all of the components of the oscillator circuit at each temperature level shall be allowed prior to frequency measurement. The short-term transient effects on the frequency of the transmitter due to keying (except for broadcast transmitters) and any heating element cycling normally occurring at each ambient temperature level also shall be shown. Only the portion or portions of the transmitter containing the frequency determining and stabilizing circuitry need be subjected to the temperature variation test.

(b) The frequency stability shall be measured with variation of primary supply voltage as follows:

- (1) Vary primary supply voltage from 85 to 115 percent of the nominal value for other than hand carried battery equipment.
- (2) For hand carried, battery powered equipment, reduce primary supply voltage to the battery operating end point, which shall be specified by the manufacturer.

(3) The supply voltage shall be measured at the input to the cable normally provided with the equipment, or at the power supply terminals if cables are not normally provided. Effects on frequency of transmitter keying (except for broadcast transmitters) and any heating element cycling at the nominal supply voltage and at each extreme also shall be shown.

(c) When deemed necessary, the Commission may require tests of frequency stability under conditions in addition to those specifically set out in paragraphs (a), (b), (c) of this section. (For example, measurements showing the effect of proximity to large metal objects, or of various types of antennas, may be required for portable equipment.)

The EUT can only work in such extreme voltage 3.6V and 4.2V, so here the EUT is tested in the 3.6V and 4.2V.

### Test Set up

Connect the EUT to the Wireless Communication test set CMU200 via the connector. Then measure the frequency error by the Wireless Communication test set CMU200. The EUT's output is matched with a 50 Ω load.

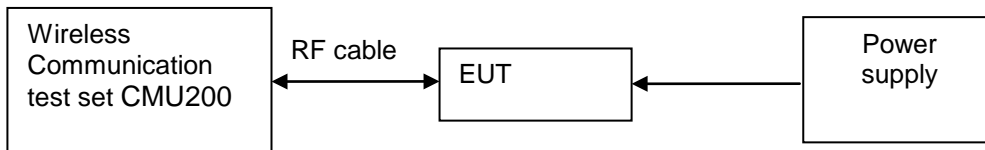

Figure 7. Test Set up

### 6.9.4 Measurement Results

#### 6.9.4.1 Measurement Results vs. Variation of Temperature

- **TM1,3.7V DC Channel No.661(1880.0MHz)**

Measurement Results vs. Variation of Temperature - TM1

Temperature	Nominal Frequency (MHz)	Measured Frequency Error(Hz)	Result
-30 °C	1880.0	-10	Pass
-20 °C	1880.0	6	Pass
-10 °C	1880.0	-11	Pass
0 °C	1880.0	5	Pass
+10 °C	1880.0	17	Pass
+20 °C	1880.0	19	Pass
+30 °C	1880.0	-10	Pass
+40 °C	1880.0	13	Pass



+50 °C	1880.0	9	Pass
--------	--------	---	------

● **TM2, 3.7V DC Channel No.661(1880.0MHz)**

Measurement Results vs. Variation of Temperature - TM2

Temperature	Nominal Frequency (MHz)	Measured Frequency Error(Hz)	Result
-30 °C	1880.0	8	Pass
-20 °C	1880.0	-12	Pass
-10 °C	1880.0	-5	Pass
0 °C	1880.0	-15	Pass
+10 °C	1880.0	-12	Pass
+20 °C	1880.0	-13	Pass
+30 °C	1880.0	-10	Pass
+40 °C	1880.0	-17	Pass
+50 °C	1880.0	-12	Pass

● **TM3, 3.7V DC Channel No.9400(1880.0MHz)**

Measurement Results vs. Variation of Temperature - TM3

Temperature	Nominal Frequency (MHz)	Measured Frequency Error(Hz)	Result
-30 °C	1880.0	-5	Pass
-20 °C	1880.0	8	Pass
-10 °C	1880.0	-12	Pass
0 °C	1880.0	10	Pass
+10 °C	1880.0	17	Pass
+20 °C	1880.0	-11	Pass
+30 °C	1880.0	13	Pass
+40 °C	1880.0	-10	Pass
+50 °C	1880.0	-13	Pass



### 6.9.4.2 Measurement Results vs. Variation of Voltage

- **TM1, 25 °C ,Channel No. 661(1880.0MHz)**

Measurement Results vs. Variation of Voltage - TM1

Voltage	Nominal Frequency (MHz)	Measured Frequency Error(Hz)	Result
+4.2V	1880.0	-5	Pass
+3.7V	1880.0	-9	Pass
+3.6V	1880.0	-12	Pass

- **TM2, 25 °C ,Channel No. 661(1880.0MHz)**

Measurement Results vs. Variation of Voltage - TM2

Voltage	Nominal Frequency (MHz)	Measured Frequency Error(Hz)	Result
+4.2V	1880.0	6	Pass
+3.7V	1880.0	-13	Pass
+3.7V	1880.0	-6	Pass

- **TM3, 25 °C ,Channel No. 9400(1880.0MHz)**

Measurement Results vs. Variation of Voltage - TM3

Voltage	Nominal Frequency (MHz)	Measured Frequency Error(Hz)	Result
+4.2V	1880.0	-17	Pass
+3.7V	1880.0	-12	Pass
+3.6V	1880.0	9	Pass

### 6.9.5 Conclusion

The equipment **PASSED** the requirement of this clause.



## 7 System Measurement Uncertainty

For a 95% confidence level, the measurement expanded uncertainties for defined systems, in accordance with the recommendations of ISO 17025 as following:

System Measurement Uncertainty

Items		Extended Uncertainty
Effective Isotropic radiated power of Transmitter	EIRP (dBm)	U=3dB; k=2
Band Width	Magnitude (%)	U=0.2%; k=2
Band Edge Compliance	Disturbance Power(dBm)	U=2.0dB; k=2
Conducted Spurious Emission at Antenna Terminal	Disturbance Power(dBm)	U=2.0dB; k=2
Frequency Stability	Frequency Accuracy(ppm)	U=0.21ppm; k=2





## 8 Appendices

Appendix A	Measurement Results Modulation Characteristics
Appendix B	Measurement Results Occupied Bandwidth
Appendix C	Measurement Results Band Edges
Appendix D	Measurement Results Spurious Emission at Antenna Terminal
Appendix E	Measurement Results Radiated Spurious Emissions
Appendix F	Measurement Results Receiver Spurious Emissions
Appendix G	Photos of Radiated Spurious Emissions