



中国认可
国际互认
检测
TESTING
CNAS L0310



FCC

RF Test Report

Product Name: LTE CPE

Model Number: B525s-65a

Report No: SYBH(Z-RF)007012017-2003

FCC ID: QISB525A-65A

Reliability Laboratory of Huawei Technologies Co.

(Global Compliance and Testing Center of Huawei Technologies Co., Ltd)

Administration Building, Headquarters of Huawei Technologies Co., Ltd., Bantian, Longgang District,
Shenzhen, 518129, P.R.C

Tel: +86 755 28780808

Fax: +86 755 89652518



Notice

1. The laboratory has Passed the accreditation by China National Accreditation Service for Conformity Assessment (CNAS). The accreditation number is L0310.
2. The laboratory has Passed the accreditation by The American Association for Laboratory Accreditation (A2LA). The accreditation number is 2174.01.
3. The laboratory has been listed by the US Federal Communications Commission to perform electromagnetic emission measurements. The site recognition number is 97456.
4. The laboratory has been listed by Industry Canada to perform electromagnetic emission measurements. The recognition numbers of test site are 6369A-1.
5. The test report is invalid if not marked with the signatures of the persons responsible for preparing and approving the test report.
6. The test report is invalid if there is any evidence of erasure and/or falsification.
7. The test report is only valid for the test samples.
8. Content of the test report, in part or in full, cannot be used for publicity and/or promotional purposes without prior written approval from the laboratory.
9. The laboratory has Passed the accreditation by China National Accreditation Service for Conformity Assessment (CNAS). The accreditation number is L0310.
10. The laboratory (Reliability Lab of Huawei Technologies Co., Ltd) is also named as “Global Compliance and Testing Center of Huawei Technologies Co., Ltd”, the both names have coexisted since 2009.



Applicant: Huawei Technologies Co., Ltd.
Address: Administration Building, Headquarters of Huawei Technologies Co., Ltd.,
Bantian, Longgang District, Shenzhen, 518129, P.R.C

Date of Receipt Sample: 2017-01-17
Start Date of Test: 2017-01-17
End Date of Test: 2017-02-24

Test Result: Pass

Approved by Senior Engineer: 2017-02-27 Roger Zhang *Roger Zhang*

Date Name Signature

Prepared by: 2017-02-27 zhoulngbo *zhoulng bo*

Date Name Signature



CONTENT

1 General Information.....5
1.1 Applied Standard.....5
1.2 Test Location5
1.3 Test Environment Condition.....5
2 Test Summary6
2.1 Measurement Technical Requirements.....6
3 Description of the Equipment under Test (EUT)7
3.1 General Description7
3.2 EUT Identity7
3.3 Technical Description.....8
4 General Test Conditions / Configurations9
4.1 Test Modes9
4.2 EUT Configurations.....9
4.3 Test Environments11
4.4 Test Setups.....12
4.5 Test Conditions13
5 Main Test Instruments14
6 Appendixes.....15



1 General Information

1.1 Applied Standard

Applied Rules: 47 CFR FCC Part 2, Subpart J 2014
 47 CFR FCC Part 15, Subpart C 2014
 47 CFR FCC Part 15, Subpart E 2014

Test Method: KDB 789033 D02 General UNII Test Procedures New Rules v01r03
 FCC KDB 662911 D01 Multiple Transmitter Output v02

1.2 Test Location

Test Location : Reliability Laboratory of Huawei Technologies Co., Ltd.
Address: Administration Building, Headquarters of Huawei Technologies Co., Ltd., Bantian, Longgang
 District, Shenzhen, 518129, P.R.C

1.3 Test Environment Condition

Temperature: 19.5 to 25 °C (Ambient)
Relative Humidity: 40 to 55 % (Ambient)
Atmospheric Pressure: Not applicable



2 Test Summary

2.1 Measurement Technical Requirements

2.1.1 U-NII (5150-5250)

Test Item	Band	FCC Rule	Requirements	Test Result	Verdict
Emission Bandwidth	5150-5250	15.403(i) 15.407(a)(1)	No limit.	Appendix A	Pass
	5250-5350	15.403(i) 15.407(a)(2)			
Occupied Bandwidth	5150-5250	KDB 789033 §D	No limit	Appendix B	Pass
Duty Cycle	--	--	No limit.	Appendix C	Pass
Maximum Conducted Output Power	5150-5250	15.407(a)(1) 15.407(a)(4)	< 250mW (avg during transmission)	Appendix D	Pass
Peak Power Spectral Density	5150-5250	15.407(a)(1) 15.407(a)(4)	<11dBm/MHz (avg during transmission)	Appendix E	Pass
Unwanted Emissions	5150-5250	15.407(b)(1) 15.407(b)(6) 15.407(b)(7) 15.209	<ul style="list-style-type: none"> ● F<1GHz: §15.209/§7.2.5 limit (QP). ● F≥1GHz & out-restricted: <-27dBm/MHz PK e.i.r.p. (exl. 5.15-5.35 GHz). ● F≥1GHz & in-restricted: §15.209/§7.2.5 limit (AV&PK). 	Appendix F	Pass
Frequency Stability	5150-5250	15.407(g)	FCC Part 15.407(g)	Appendix G	Pass



3 Description of the Equipment under Test (EUT)

3.1 General Description

B525s-65a LTE/DC-HSPA+/WCDMA/EDGE/GPRS/GSM multi-mode LTE CPE is subscriber equipment in the LTE/UMTS/GSM system and support WLAN 802.11a/b/g/n/ac. B525s-65a implement such functions as RF signal receiving/transmitting, LTE/DC-HSPA+/WCDMA and EDGE/GPRS/GSM protocol processing, data service etc. It provides USIM card interface, RJ45/RJ11 Ethernet interface, USB port and external antenna interfaces

NOTE: Only 5G WIFI test data included in this report.

3.2 EUT Identity

NOTE: Unless otherwise noted in the report, the functional boards installed in the units shall be selected from the below list, but not means all the functional boards listed below shall be installed in one unit.

3.2.1 Board

Board		
Description	Hardware Version	Software Version
Main Board	WL1B525I	11.232.08.DM.00

3.2.2 Sub-Assembly

Sub-Assembly			
Sub-Assembly Name	Model	Manufacturer	Description
Adapter	HW-120200U01	Huawei Technologies Co., Ltd.	Input Voltage :100-240V ~50/60Hz 0.8A Output Voltage:  12V 2A Rated Power: 24W



3.3 Technical Description

Characteristics	Description			
IEEE 802.11 WLAN Mode Supported	<input checked="" type="checkbox"/> 802.11a (20 MHz channel bandwidth), <input checked="" type="checkbox"/> 802.11n (20 MHz channel bandwidth), <input checked="" type="checkbox"/> 802.11n (40 MHz channel bandwidth), <input checked="" type="checkbox"/> 802.11ac (20 MHz channel bandwidth), <input checked="" type="checkbox"/> 802.11ac (40 MHz channel bandwidth), <input checked="" type="checkbox"/> 802.11ac (80 MHz channel bandwidth),			
TX/RX Operating Range	All	$f_c = 5000 \text{ MHz} + N * 5 \text{ MHz}$, where: - f_c = "Operating Frequency" in MHz, - N = "Channel Number".		
	5150-5250 MHz (U-NII)	$N = 36$ to 48 with step of 4 for the 20 MHz channel bandwidth. $N = 38$ to 46 with step of 4 for the 40 MHz channel bandwidth. $N = 42$ for the 80 MHz channel bandwidth.		
Modulation Type	BPSK/QPSK/16QAM/64QAM (OFDM).			
Emission Designator	U-NII(5150-5250	20M4G7D (for 802.11a mod) 21M0G7D (for 802.11n 20 MHz mode) 40M4G7D (for 802.11n 40 MHz mode) 21M2G7D (for 802.11ac 20 MHz mode) 40M3G7D (for 802.11ac 40 MHz mode) 83M1G7D (for 802.11ac 80 MHz mode)		
TPC	<input type="checkbox"/> Supported, <input checked="" type="checkbox"/> Not Supported			
Antenna	Type	<input type="checkbox"/> External, <input checked="" type="checkbox"/> Integrated		
	Ports	<input checked="" type="checkbox"/> Ant 1, <input checked="" type="checkbox"/> Ant 2, <input checked="" type="checkbox"/> Ant 3, <input type="checkbox"/> Ant 4		
	Smart System	<input checked="" type="checkbox"/> SISO (for 802.11a/n/ac), <input checked="" type="checkbox"/> MIMO (for 802.11n/ac), <input type="checkbox"/> Diversity (for 802.11a) : Tx & Rx		
	Gain	Ant1:1 dBi (per antenna port, max.) Ant2:1 dBi (per antenna port, max.) Ant3:1 dBi (per antenna port, max.)		
	Remark	When the EUT is put into service, the practical maximum antenna gain should NOT exceed the value as described above.		
Power Supply	Type	<input checked="" type="checkbox"/> AC/DC Adapter	<input type="checkbox"/> PoE:	<input type="checkbox"/> Other:



4 General Test Conditions / Configurations

4.1 Test Modes

NOTE: Worst cases for each IEEE 802.11 mode are selected to perform tests.

Test Mode	Test Modes Description
11A	IEEE 802.11a with data rate of 6 Mbps using SISO mode.
11N20	IEEE 802.11n with data rate of MCS0 and bandwidth of 20 MHz using SISO mode.
11N20m	IEEE 802.11n with data rate of MCS8 and bandwidth of 20 MHz using MIMO mode.
11N40	IEEE 802.11n with data rate of MCS0 and bandwidth of 40 MHz using SISO mode.
11N40m	IEEE 802.11n with data rate of MCS8 and bandwidth of 40 MHz using MIMO mode.
11AC20	IEEE 802.11ac with data rate of MCS0 and bandwidth of 20 MHz using SISO mode.
11AC20m	IEEE 802.11ac with data rate of MCS8 and bandwidth of 20 MHz using MIMO mode.
11AC40	IEEE 802.11ac with data rate of MCS0 and bandwidth of 40 MHz using SISO mode.
11AC40m	IEEE 802.11ac with data rate of MCS8 and bandwidth of 40 MHz using MIMO mode.
11AC80	IEEE 802.11ac with data rate of MCS0 and bandwidth of 80 MHz using SISO mode.
11AC80m	IEEE 802.11ac with data rate of MCS8 and bandwidth of 80 MHz using MIMO mode.

4.2 EUT Configurations

4.2.1 General Configurations

Configuration	Description
Test Antenna Ports	Until otherwise specified, <ul style="list-style-type: none"> All TX tests are performed at all TX antenna ports of the EUT, and All RX tests are performed at all RX antenna ports of the EUT.
Multiple RF Sources	Other than the tested RF source of the EUT, other RF source(s) are disabled or shutdown during measurements.

4.2.2 Customized Configurations

4.2.2.1 U-NII

Test Mode	Test Channel	Frequency [MHz]	Antenna Port	Power Conf., per Port	Duty cycle [%]
11A	36	5180	Ant 1	12	98
11A	48	5240	Ant 1	12	98
11A	36	5180	Ant 2	12	98
11A	48	5240	Ant 2	12	98



11A	36	5180	Ant 3	12	98
11A	48	5240	Ant 3	12	98
11N20	36	5180	Ant 1	12	98
11N20	48	5240	Ant 1	12	98
11N20	36	5180	Ant 2	12	98
11N20	48	5240	Ant 2	12	98
11N20	36	5180	Ant 3	12	98
11N20	48	5240	Ant 3	12	98
11N20M	36	5180	Ant 1	11	96
11N20M	48	5240	Ant 1	11	96
11N20M	36	5180	Ant 2	11	96
11N20M	48	5240	Ant 2	11	96
11N20M	36	5180	Ant 3	11	96
11N20M	48	5240	Ant3	11	96
11N40	38	5190	Ant 1	12	96
11N40	46	5230	Ant 1	12	96
11N40	38	5190	Ant 2	12	96
11N40	46	5230	Ant 3	12	96
11N40	38	5190	Ant 3	12	96
11N40M	38	5190	Ant 1	11	93
11N40M	46	5230	Ant 1	11	93
11N40M	38	5190	Ant 2	11	92
11N40M	46	5230	Ant 2	11	92
11N40M	38	5190	Ant 3	11	92
11N40M	46	5230	Ant 3	11	92
11AC20	36	5180	Ant 1	12	98
11AC20	48	5240	Ant 1	12	98
11AC20	36	5180	Ant 2	12	98
11AC20	48	5240	Ant 2	12	98
11AC20	36	5180	Ant 3	12	98
11AC20	48	5240	Ant 3	12	98
11AC20M	36	5180	Ant 1	11	97
11AC20M	48	5240	Ant 1	11	97
11AC20M	36	5180	Ant 2	11	97
11AC20M	48	5240	Ant 2	11	97
11AC20M	36	5180	Ant 3	11	97
11AC20M	48	5240	Ant 3	11	97
11AC40	38	5190	Ant 1	12	96
11AC40	46	5230	Ant 1	12	96
11AC40	38	5190	Ant 2	12	96
11AC40	46	5230	Ant 2	12	96



11AC40	38	5190	Ant 3	12	96
11AC40	46	5230	Ant 3	12	96
11AC40M	38	5190	Ant 1	11	95
11AC40M	46	5230	Ant 1	11	95
11AC40M	38	5190	Ant 2	11	94
11AC40M	46	5230	Ant 2	11	94
11AC40M	38	5190	Ant 3	11	92
11AC40M	46	5230	Ant 3	11	92
11AC80	42	5210	Ant 1	12	92
11AC80	42	5210	Ant 2	12	92
11AC80	42	5210	Ant 3	12	92
11AC80M	42	5210	Ant 1	11	90
11AC80M	42	5210	Ant 2	11	89
11AC80M	42	5210	Ant 3	11	89

4.3 Test Environments

Environment Parameter	Selected Values During Tests	
Relative Humidity	Ambient	
Temperature	TN	Ambient
Voltage	VL	10.8V
	VN	12V
	VH	13.2V

NOTE: VL= lower extreme test voltage
 VN= nominal voltage
 VH= upper extreme test voltage
 TN= normal temperature

4.4 Test Setups

4.4.1 Test Setup 1

The WLAN component's antenna ports(s) of the EUT are connected to the measurement instrument per an appropriate attenuator. The EUT is controlled by PC/software to emit the specified signals for the purpose of measurements.

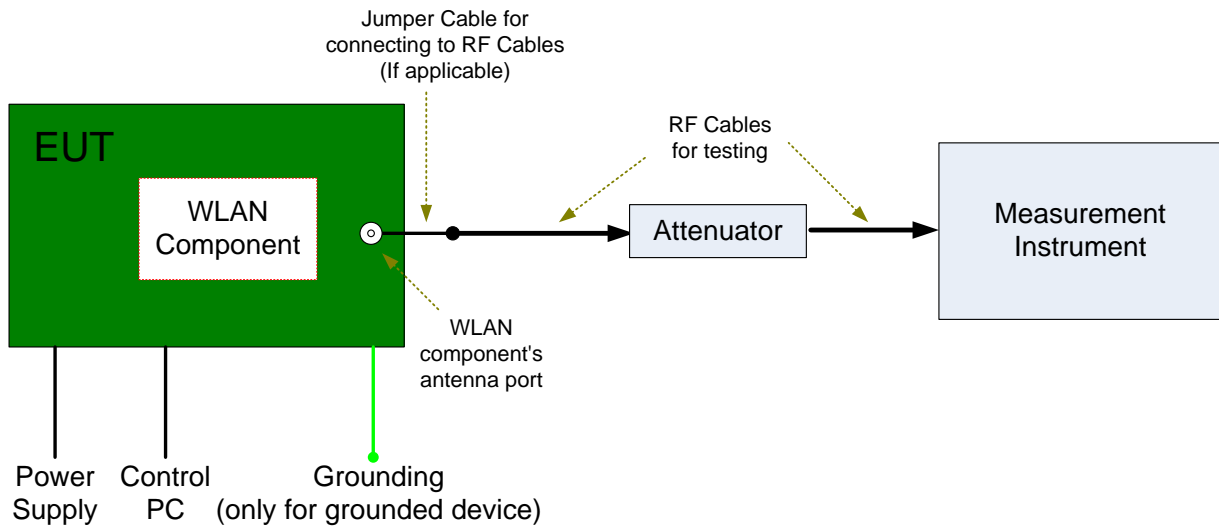



4.5 Test Conditions

4.5.1 U-NII

Test Case	Test Conditions	
	Configuration	Description
Emission Bandwidth (EBW)	Meas. Method	FCC KDB 789033 §C).
	Test Env.	NTNV
	Test Setup	Test Setup 1
	EUT Conf.	All EUT conf. with Tx modes.
Occupied Bandwidth (OBW)	Meas. Method	FCC KDB 789033 §D).
	Test Env.	NTNV
	Test Setup	Test Setup 1
	EUT Conf.	All EUT conf. with Tx modes.
Maximum Conducted Output Power	Meas. Method	FCC KDB 789033 §E)2)b) Method SA-1 and d) Method SA-2.
	Test Env.	NTNV
	Test Setup	Test Setup 1
	EUT Conf.	All EUT conf. with Tx modes.
Peak Power Spectral Density	Meas. Method	FCC KDB 789033 §F).
	Test Env.	NTNV
	Test Setup	Test Setup 1
	EUT Conf.	All EUT conf. with Tx modes.
Unwanted Emissions (Cond.)	Meas. Method	FCC KDB 789033 §G), Conducted (antenna-port). NOTE: Antenna-port conducted measurements (Cond.) are acceptable as an alternative to radiated measurements (Rad.) for demonstrating compliance to the limits in the restricted frequency bands. If conducted measurements are performed, then proper impedance matching must be ensured and an additional radiated test (Rad-a) for cabinet/case emissions will also be required.
	Test Env.	NTNV
	Test Setup	Test Setup 1
	EUT Conf.	5150-5250 All EUT Test Mode 20 MHz bandwidth: Ch.36, Ch.48 40 MHz bandwidth: Ch.38, Ch.46 80 MHz bandwidth: Ch.42
Frequency Stability	Meas. Method	15.407(g) Frequency Stability
	Test Env.	(1)V _L , V _N and V _H of Rated Voltage at Ambient Climate. (2) -5 °C,5°C,15°C,-25°C,35°C,45°C,50°C
	Test Setup	Test Setup 1
	EUT Conf.	Ch.36,Ch.165



5 Main Test Instruments

NOTE: Unless otherwise specified, the calibration intervals for test instruments were Annual (per year). The other intervals, if applicable, are marked with (##y), which denotes ## years calibration interval.

Main Test Equipments					
Equipment Name	Manufacturer	Model	Serial Number	Cal Date	Cal- Due
Power supply	KEITHLEY	2303	1342889	2016/10/13	2017/10/12
Wireless Communication Test set	Agilent	N4010A	MY49081592	2016/8/5	2017/8/5
Universal Radio Communication Tester	R&S	CMU200	123299	2016/11/14	2017/11/14
Spectrum Analyzer	Agilent	N9020A	MY52090652	2016/6/29	2017/6/29
Universal Radio Communication Tester	R & S	CMW500	126854	2016/12/29	2017/12/29
Signal Analyzer	R&S	FSQ31	200021	2016/8/5	2017/8/5
Spectrum Analyzer	Agilent	N9030A	MY49431698	2016/8/5	2017/8/5
Temperature Chamber	WEISS	WKL64	56246002940010	2016/12/21	2017/12/20
Signal generator	Agilent	E8257D	MY49281095	2016/8/5	2017/8/5
Vector Signal Generator	R&S	SMU200A	104162	2016/8/5	2017/8/5
Test receiver	R&S	ESU26	100387	2016/6/21	2017/6/21
Spectrum analyzer	R&S	FSU3	200474	2016/5/24	2017/5/24
Spectrum analyzer	R&S	FSU43	100144	2016/6/2	2017/6/2
LOOP Antennas(9kHz-30MHz)	R&S	HFH2-Z2	100262	2015/4/30	2017/4/29
LOOP Antennas(9kHz-30MHz)	R&S	HFH2-Z2	100263	2015/4/30	2017/4/29
Trilog Broadband Antenna (30M~3GHz)	SCHWARZBECK	VULB 9163	9163-490	2015/4/30	2017/4/29
Trilog Broadband Antenna (30M~3GHz)	SCHWARZBECK	VULB 9163	9163-520	2015/4/30	2017/4/29
Double-Ridged Waveguide Horn Antenna (1G~18GHz)	R&S	HF907	100304	2015/4/30	2017/4/29
double ridged horn antenna (0.8G-18GHz)	R&S	HF907	100305	2015/4/30	2017/4/29
Pyramidal Horn Antenna(18GHz-26.5GHz)	ETS-Lindgren	Sep-60	5140299	2015/7/15	2017/7/14
Artificial Main Network	R&S	ENV4200	100134	2016/6/2	2017/6/2
Line Impedance Stabilization Network	R&S	ENV216	100382	2016/6/2	2017/6/2



6 Appendixes

Appendix No.	Description
SYBH(Z-RF)007012017-2003-A	Appendix for 5G WLAN

END